

1.Product Introduction

AH541 is a Hall switch chip designed based on BCDMOS technology. The sensors includes hall devices with temperature compensation, dynamic offset cancellation amplifiers, comparators, and output stages. The chip outputs current. The comparator compares the actual magnetic flux with a fixed reference value (switching point) to control the current level of the output MOSFET. Active offset compensation can generate magnetic characteristics with specific temperature coefficients under various power supply voltages. In addition, mechanical stress has little effect on magnetic parameters. In addition, mechanical stress has little effect on the magnetic parameters of the chip.

The series of chip sensors is suitable for industrial and automotive applications, with an ambient temperature range of -40 °C to 150 °C and supply voltage range of 3.0V to 30V. AH541 provides a variety of packages to customers: TO92S, SOT23 (small), SOT23. All packages are RoHs compliant. The product has passed AEC-Q100 certification.



2.Function

- AEC-Q100 Grade 0 Automotive Level Certification
- Operating Vcc Range:3.0V~30V
- ESD: ±12kV
- High mechanical stress suppression ability
- Switching points with specific temperature coefficients
- Temperature range: -40°C~150°C
- Reverse-voltage protection at Vcc pin
- Suitable for automobiles and industries

3.Application

- Speed and RPM sensing
- Tachometer sensor、Flow-rate sensing
- DC motor, fan control, robotics control
- Proximity sensor、Position sensor
- Seat belt buckles、hood/trunk/door latches
- Sunroof/convertible top/tailgate
- Liftgate activation
- Brake/clutch pedals
- Electric power steering(EPS)
- Transmission shifting
- Wiper motor

AH541

Two wire current Hall switch sensor



Alfa Electronics Co., Ltd

4. Products packaging

Part No.	Packages	temperature range	Packing
AH541UA	T092S	-40°C~150°C	1000pcs/bag
AH541SU	SOT23-3L	-40°C~150°C	3000pcs/reel
AH541SS	SOT23 (small)	-40°C~150°C	3000pcs/reel

AH541

Two wire current Hall switch sensor



Alfa Electronics Co., Ltd

Table of Contents

1.Product Introduction	1
2.Function	1
3.Application.....	1
4.Products packaging	2
5.Functional Block Diagram.....	4
6. Pin information	4
7.Absolute Maximum Ratings	5
8.Recommended operating conditions.....	5
9.Electrical Parameters	6
10.Magnetic Parameters.....	6
11.Magnetic Characteristics.....	6
12.Typical Application Circuit.....	7
13.Characteristic Performance	8
14.Package Material Information.....	9
15.Note.....	12
16. Historical Version.....	12

AH541

Two wire current Hall switch sensor



Alfa Electronics Co.,Ltd

5. Functional Block Diagram

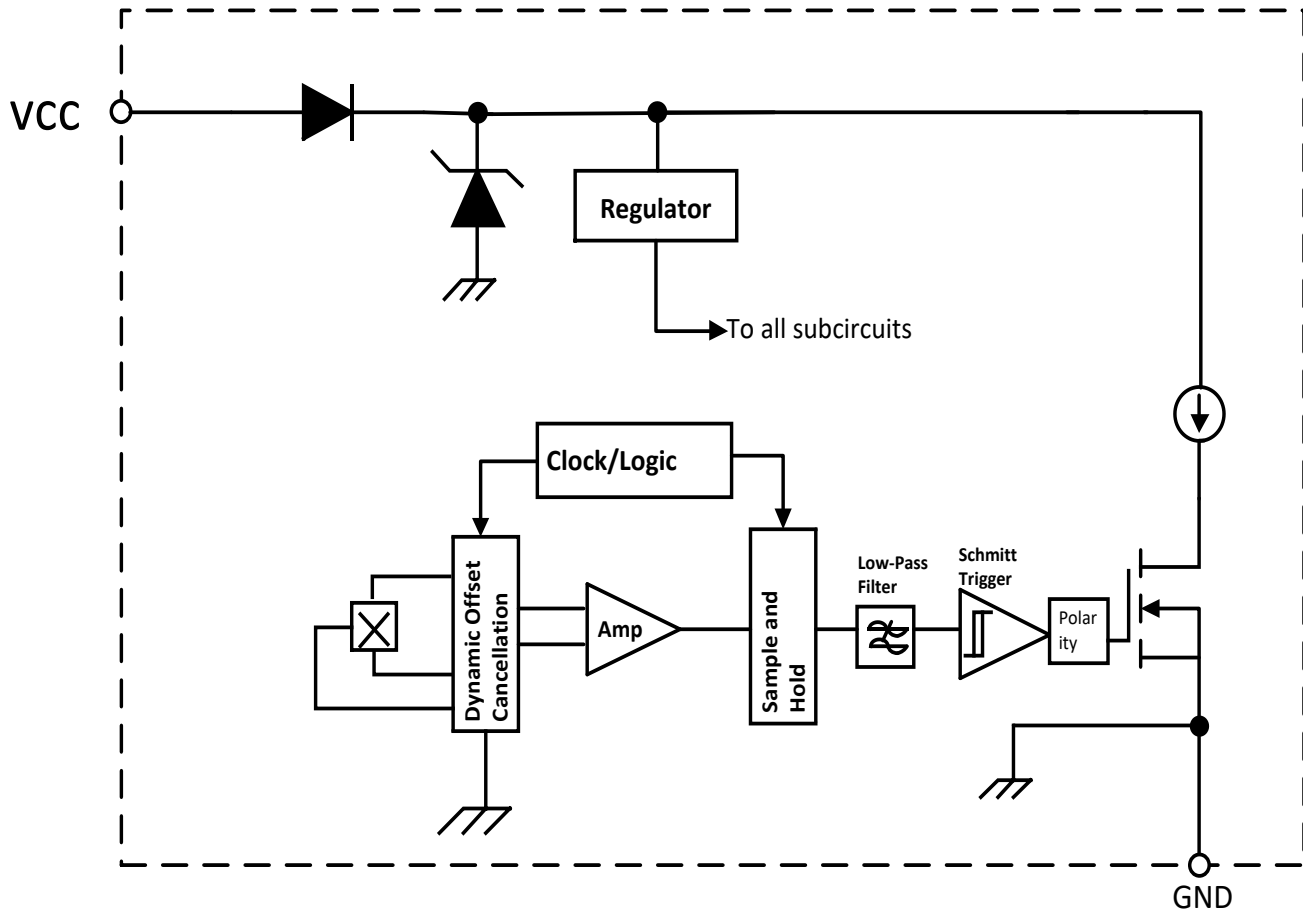

6. Pin information

No.	Name	Functions
1	V _{CC}	Power supply voltage 2.7V~30V
2	GND	Ground wire
3	V _{OUT}	NC (undefined)

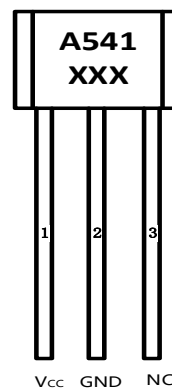

T092S

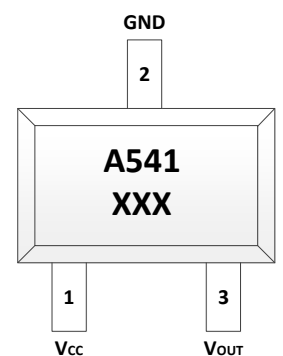

SOT23 (small I) /SOT23-3L

7. Absolute Maximum Ratings

Absolute maximum ratings are limited values to be applied chips, and beyond which the absolute maximum rating may be damage chips. Although the functionality is not necessarily damaged, exposure to absolute maximum rating conditions for an extended period of time may affect device reliability

Symbol	Parameters	Pins	Min	Max	Unit	Test condition
V _{CC}	supply voltage	1	-20	30	V	t<1000h ¹⁾
			-	34	V	t<96h ¹⁾
			-	36	V	t<5min ¹⁾
T _A	operating ambient temperature		-40	170	°C	
T _s	storage temperature		-65	170	°C	-
T _J	maximum junction temperature			165	°C	-

¹⁾No accumulated stress

8. Recommended operating conditions

When the operation of the chip exceeds the range described in the recommended operating conditions, it may lead to abnormal chip operation and may reduce reliability and service life

Symbol	Parameters	Pins	Min	Typ	Max	Unit
V _{CC}	supply voltage	1	3.0	-	30	V
T _A	operating ambient temperature	-	-40	-	150	°C

ESD ratings

Symbol	Describe	Executive standards	Max	Unit
V _{ESD}	HBM	JEDEC JS-001-2017	12	kV

AH541

Two wire current Hall switch sensor



Alfa Electronics Co.,Ltd

9. Electrical Parameters

Test conditions: $V_{CC}=3.0V\sim 30V$, $T_A=-40^{\circ}C\sim 150^{\circ}C$

Symbol	Parameters	Pins	Min	Typ	Max	Unit	Test condition
I_{VCC_LO}	Power supply low current	1	4.0	6.0	8.0	mA	$B > Brp$ ire
I_{VCC_HI}	Power supply high current	1	12	15	18	mA	$B < Bop$
I_{CCR}	reverse current				1	mA	$V_{CC}=-18V$
B_{NOISE}	Effective noise of switching points			1		Gs	Suitable for square wave signals of 1kHz

10. Magnetic Parameters

Part No.	Switch Type	TC (pp m/K)	Bop (Gs)			Brp (Gs)			BHYS (Gs)		
			Min	Typ	Max	Min	Typ	Max	Min	Typ	Max
AH541	Bipolar	0	-	43	-	-	-43	-	-	86	-

11. Magnetic Characteristics

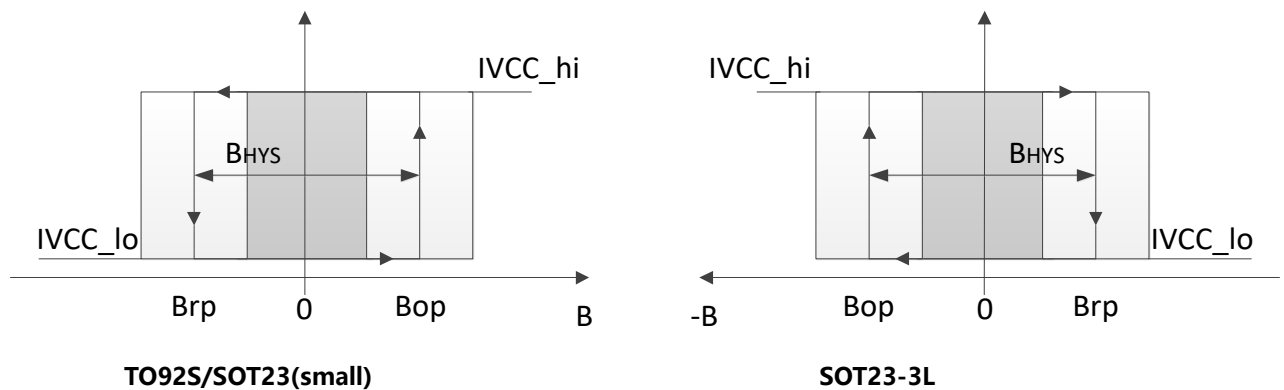

12. Typical Application Circuit

The following figure shows a simple application with a 2-wire sensor. Current consumption can be detected by measuring the voltage on the R_L . In order for the sensor to function properly, the voltage between VCC and GND must be at least V_{CCMIN} . At maximum current consumption of I_{CC_HIMAX} , the maximum R_L can be calculated as:

$$R_{Lmax} = \frac{V_{BATTmin} - V_{CCmin}}{I_{cchimax}}$$

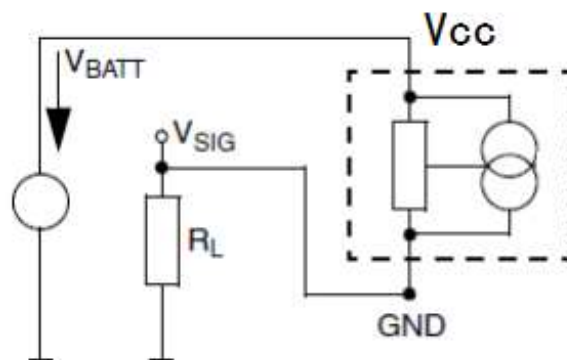

Typical Application Circuit 1

For applications with interference or radiation interference on the power line, it is recommended to place a series resistor R_V and a capacitor C_P near the sensor. In this case, the maximum R_L can be calculated as:

$$R_{Lmax} = \frac{V_{BATTmin} - V_{CCmin}}{I_{cchimax}} - R_V$$

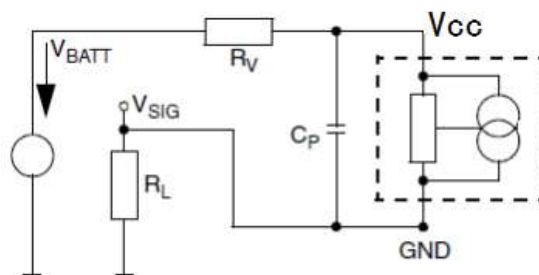

Typical Application Circuit 2



13.Characteristic Performance

$V_{cc}=5V$, Bop and Brp Characteristic Performance

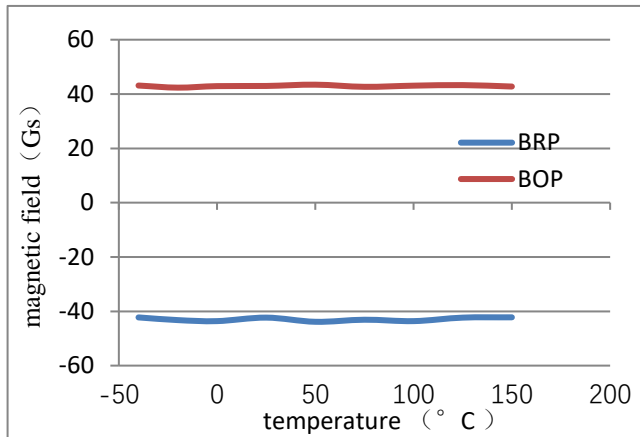

$V_{cc}=5V$, Supply current Characteristic Performance

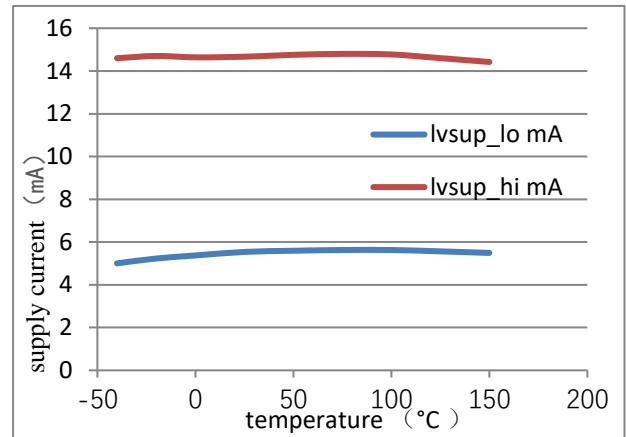

$V_{cc}=3.0\sim 30V$, Average power supply current (low) Characteristic Performance

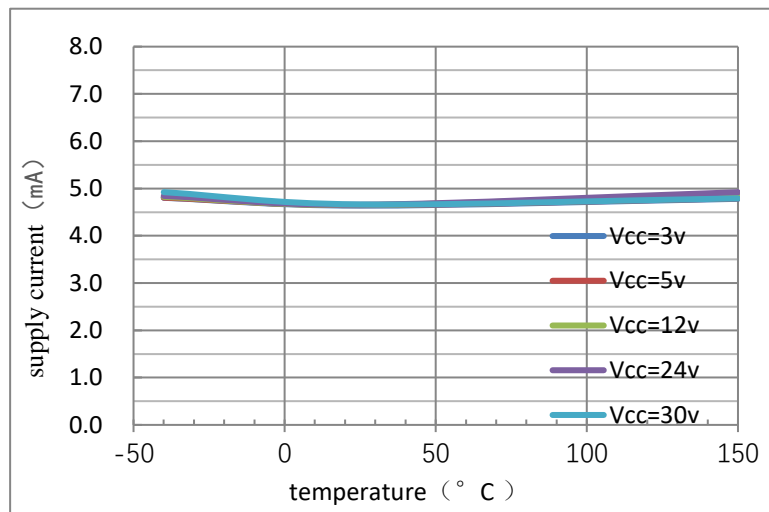

$V_{cc}=3.0\sim 30V$, Average power supply current (low) Characteristic Performance

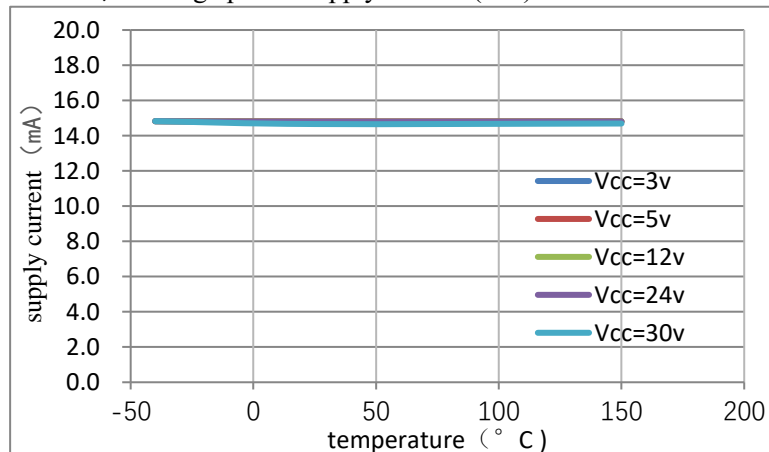

AH541

Two wire current Hall switch sensor



Alfa Electronics Co.,Ltd

14.Package Material Information

TO92S Package Size

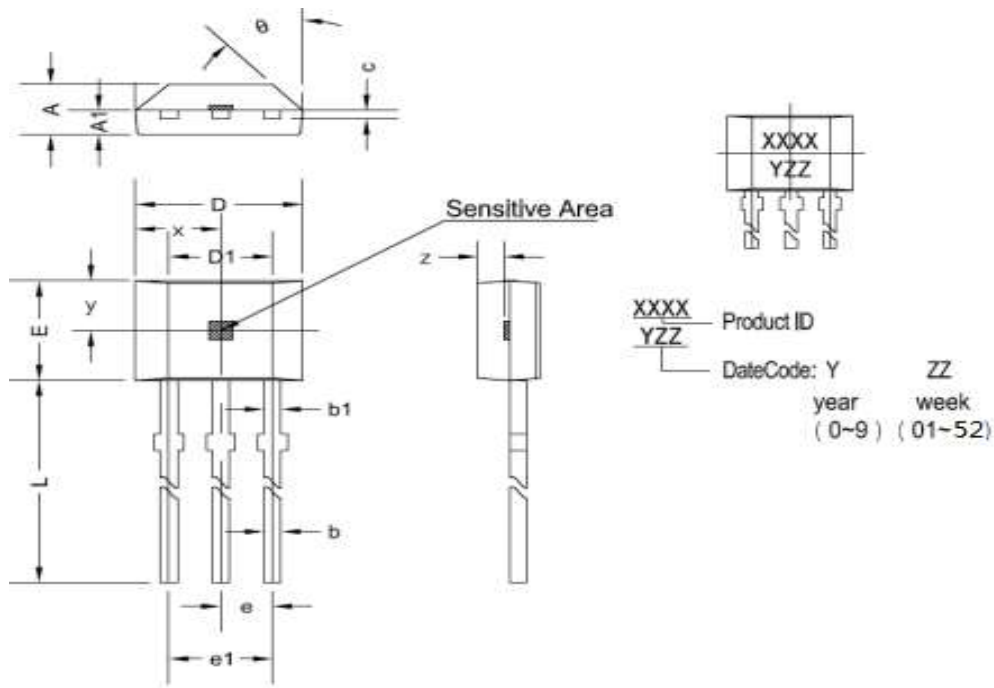

Symbol	Dimensions in Millimeters		Dimensions in Inches	
	Min	Max	Min	Max
A	1.420	1.620	0.056	0.064
A1	0.770TYP		0.030TYP	
b	2.440	2.650	0.096	0.104
b1	2.580TYP		0.102TYP	
D	3.900	4.100	0.154	0.162
E	2.900	3.100	0.114	0.122
e	1.270TYP		0.050TYP	
e1	2.540TYP		0.100TYP	
L	15.500	16.200	0.610	0.638
θ	45°TYP		45°TYP	

AH541

Two wire current Hall switch sensor



Alfa Electronics Co.,Ltd

SOT23-3L Package Size

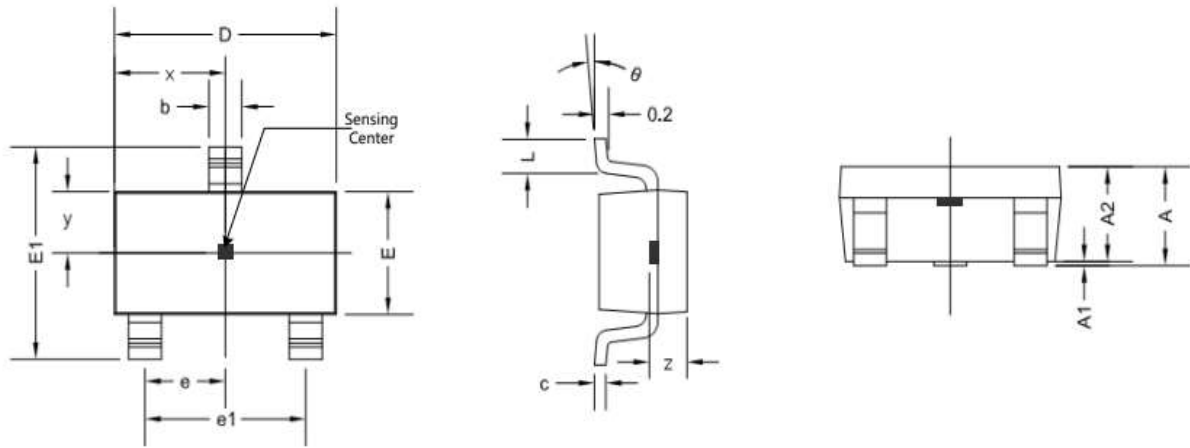

Symbol	Dimensions in Millimeters		Dimensions in Inches	
	Min	Max	Min	Max
A	1.050	1.300	0.041	0.051
A1	0.000	0.150	0.000	0.006
A2	1.000	1.200	0.039	0.047
b	0.300	0.500	0.012	0.020
c	0.080	0.220	0.003	0.009
D	2.800	3.020	0.110	0.119
E	1.500	1.700	0.059	0.067
E1	2.600	3.000	0.102	0.118
e	0.950TYP		0.037TYP	
e1	1.800	2.000	0.071	0.079
L	0.300	0.600	0.012	0.024
x	1.460TYP		0.057TYP	
y	0.800TYP		0.032TYP	
z	0.600TYP		0.024TYP	
θ	0°	8°	0°	8°

AH541

Two wire current Hall switch sensor



Alfa Electronics Co.,Ltd

SOT23 (small) Package Size

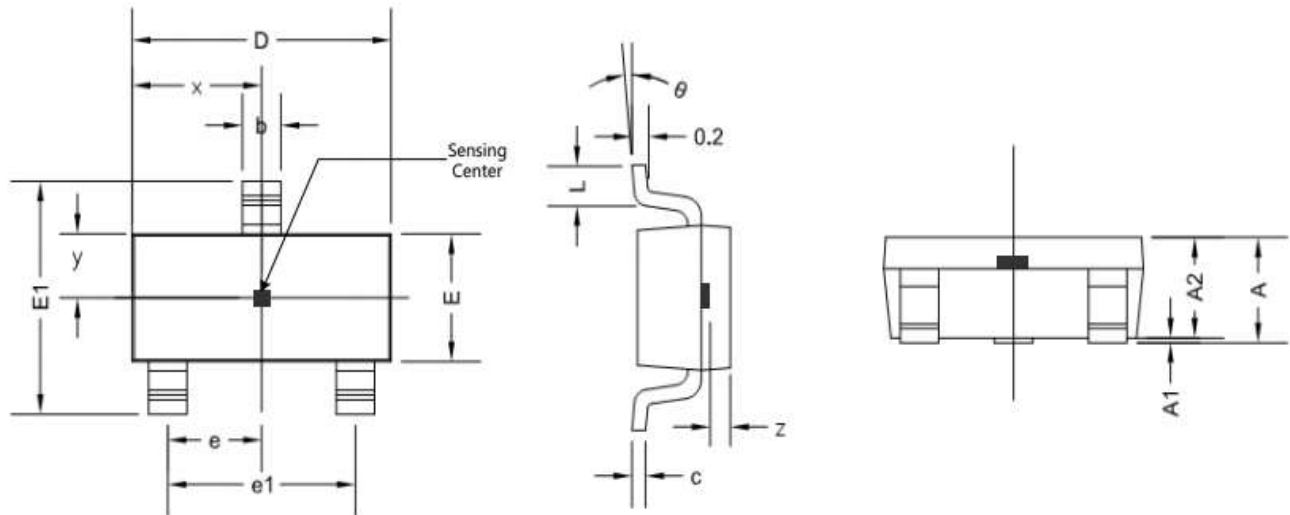

Symbol	Dimensions in Millimeters		Dimensions in Inches	
	Min	Max	Min	Max
A	0.900	1.150	0.035	0.045
A1	0.000	0.100	0.000	0.004
A2	0.900	1.100	0.035	0.043
b	0.300	0.500	0.012	0.020
c	0.132	0.202	0.005	0.008
D	2.800	3.000	0.110	0.118
E	1.200	1.400	0.047	0.055
E1	2.250	2.550	0.089	0.100
e	0.950TYP		0.037TYP	
e1	1.800	2.000	0.071	0.079
L	0.300	0.500	0.012	0.020
x	1.460TYP		0.057TYP	
y	0.650TYP		0.026TYP	
z	0.500TYP		0.020TYP	
θ	0°	8°	0°	8°

15. Note

- Hall chips are sensitive devices, and electrostatic protection measures should be taken during use, installation, and storage.
- During installation and use, mechanical stress applied to the device casing and leads should be minimized as much as possible.
- It is recommended that the welding temperature should not exceed 350 °C and the duration should not exceed 5 seconds.
- To ensure the safety and stability of Hall chips, it is not recommended to use them beyond the parameter range for a long time.

16. Historical Version

No.	Time	Describe
1	September 6th, 2022	Update Characteristic Performance.
2	December 22th, 2022	Update static voltage output error range
3	February 9th, 2023	Update IC limit of operate temperature and storage temperature
4	April 19th, 2023	Version update to V1.2

Copyright ©2018, Alfa Electronics Co., Ltd

Alfa Electronics Co., Ltd reserves the right to make, from time to time, such departures from the detail specifications as may be required to permit improvements in the performance, reliability, or manufacturability of its products. Before placing an order, the user is cautioned to verify that the information being relied upon is current.

Alfa's products are not to be used in any devices or systems, including but not limited to life support devices or systems, in which a failure of Alfa's product can reasonably be expected to cause bodily harm.

The information included herein is believed to be accurate and reliable. However, Alfa Electronics Co., Ltd assumes no responsibility for its use; nor for any infringement of patents or other rights of third parties which may result from its use.