

AH6851 HALL-EFFECT SWITCH INTEGRATED CIRCUITS

These Hall-effect switch integrated circuits are monolithic integrated circuit consisting of a voltage regulator, Hall-voltage generator, differential amplifier, schmitt trigger, temperature compensation circuit and open-collector output stage. Its input is a magnetic flux density signal and output is a digital voltage signal.

FEATURES

- . Wide supply voltage range
- . Fast response time
- . Wide frequency and temperature range
- . Long operating life
- . Small size, convenient installing
- . Output compatible with all digital logic families

TYPICAL APPLICATIONS

- . Contactless switch
- . Speed measurement
- . Isolation measurement
- . Automotive ignitor
- . Position control
- . Revolution detection
- . Brushless DC motor

ABSOLUTE MAXIMUM RATING

Parameter	Symbol	Value	Unit
Supply voltage	V_{CC}	24	V
Magnetic flux density	B	Unlimited	mT
Output OFF voltage	V_{ce}	50	V
Continuous output current	I_{OL}	50	mA
Operating temperature range	T_A	-40~125	°C
Storage temperature range	T_S	-55~150	°C

ELECTRICAL CHARACTERISTICS

$T_A=25^{\circ}C$

Parameter	Symbol	Test conditions	Type and Value			Unit
			min	typ	max	
Supply voltage	V_{CC}		4.5	-	24	V
Output saturation voltage	V_{OL}	$I_{out}=20mA \ B>B_{OP}$	-	200	400	mV
Output leakage current	I_{OH}	$V_{out}=24V \ B<B_{RP}$	-	0.1	10	μA
Supply current	I_{CC}	$V_{CC}=\text{Output open}$	-	-	10	mA
Output rise time	t_r	$R_L=820 \ \Omega \ C_L=20PF$	-	0.12	-	μS
Output fall time	t_f	$R_L=820 \ \Omega \ C_L=20PF$	-	0.18	-	μS

MAGNET CHARACTERISTICS

$V_{CC}=4.5\sim 24V$

Parameter	Symbol	Type and Value			Unit
		min	typ	max	
Operate point	B_{OP}			10.0	mT
Release point	B_{RP}	-10.0			mT
Hysteresis	B_H	2		-	mT

NOTE: 1mT=10GS

BLOCK DIAGRAM

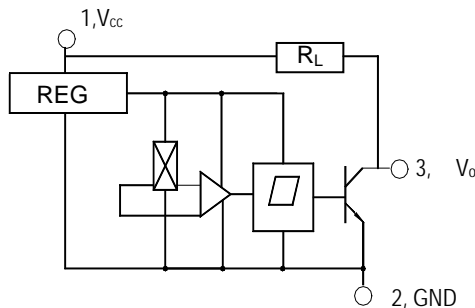

MAGNETIC-ELECTRICAL TRANSFER CHARACTERISTICS

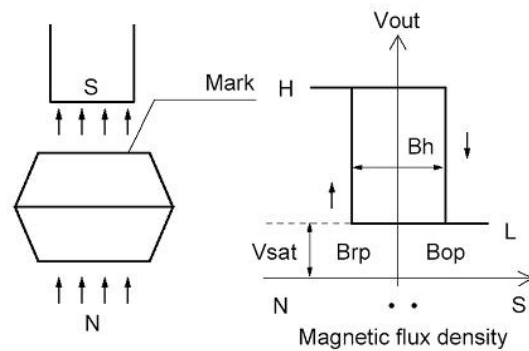

DIMENSIONS (in: mm)

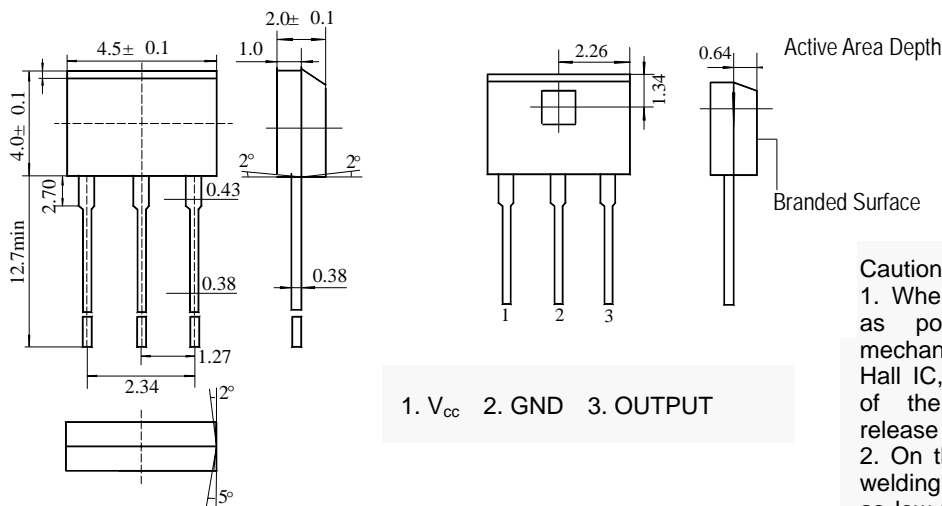

1. V_{CC} 2. GND 3. OUTPUT

TO-92T Package and Active Area

Cautions

1. When install, should as full as possible decrease the mechanical stress acting on the Hall IC, to avoid the influence of the operate point and release point.
2. On the premise of ensuring welding quality, use as possible as low welding temperature as short time.

