

General Description

The AH9248 is an ultra-sensitive Hall-effect switch with digital latched output, mainly designed for battery-operation, hand-held equipments.

Special CMOS process is used for low-voltage and low-power requirement. A chopper stabilized amplifier improves stability of magnetic switch points. A sleep-awake logic controls the IC in sleep time or awake time. This function will reduce the average operating current of the IC. During the awake time, the output is changed with the magnetic flux density. During the sleep time, the output is latched in its previous state and the current consumption will reduce to some μA .

The IC switching behaviour is omnipolar, either north or south pole sufficient strength will turn the output on. If the magnetic flux density is larger than operating point (B_{OP}), the output will be turned on; if it is less than releasing point (B_{RP}), the output will be turned off.

The AH9248 is available in TO-92S-3, SOT-23-3 and DFN-2 \times 2-3 packages which are optimized for most applications.

Features

- Micropower Operation
- 2.5 to 5.5V Power Supply
- Switching for Both Poles of a Magnet (Omnipolar)
- Stabilized Chopper
- Superior Temperature Stability
- Digital Output Signal
- Built-in Pull-up Resistor (AH9249)

Applications

- Cover Switch in Notebook PC/PDA
- Handheld Wireless Application Awake Switch
- Magnet Switch in Low Duty Cycle Applications

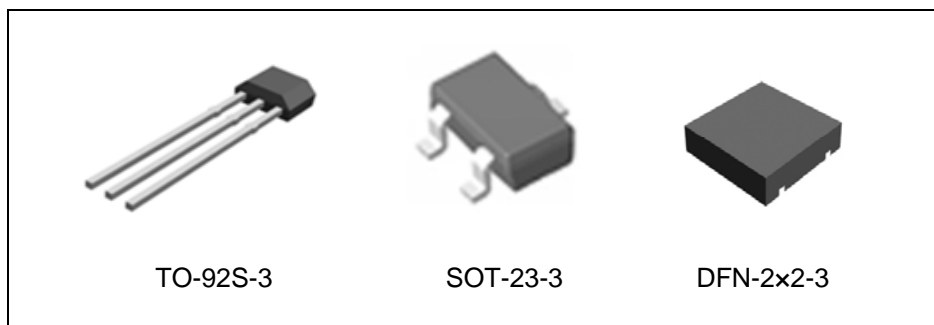

Figure 1. Package Types of AH9248

Pin Configuration

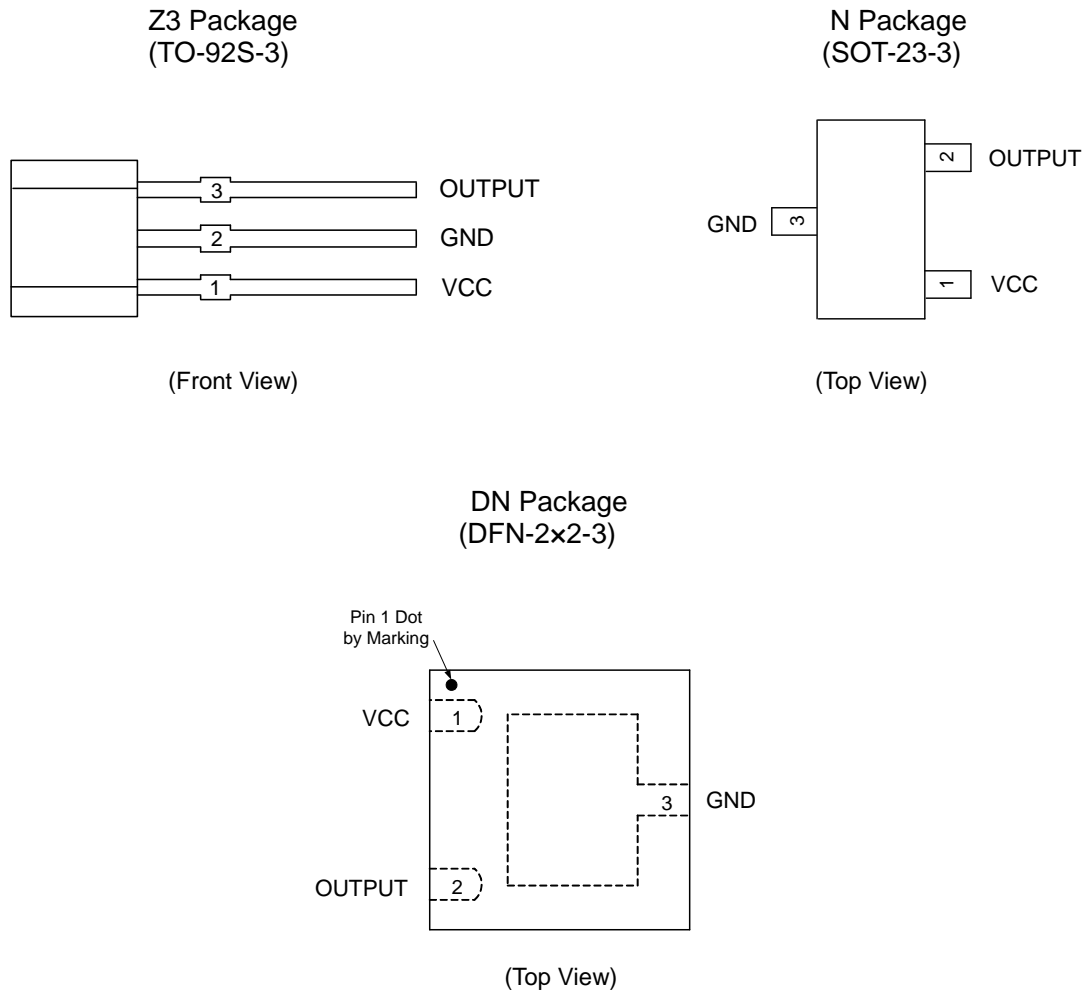
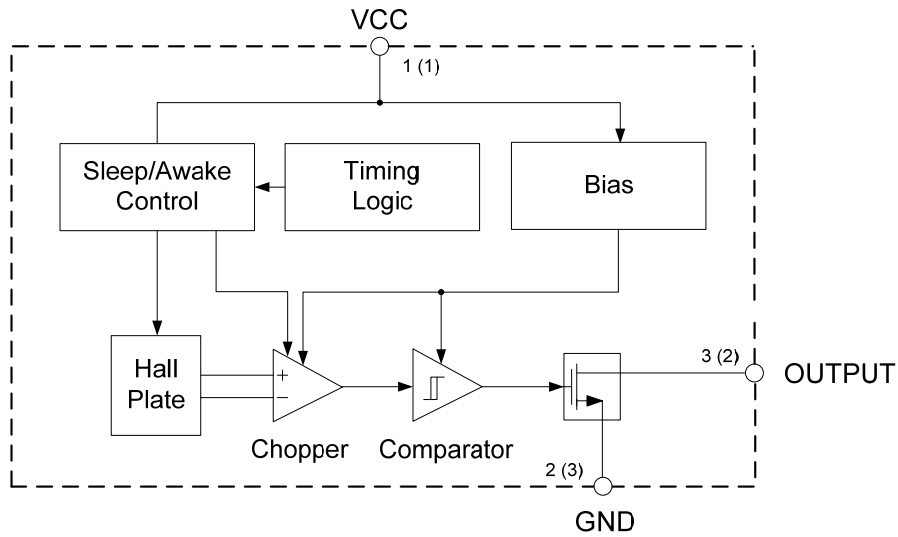

Figure 2. Pin Configuration of AH9248

Pin Description

Pin Number			Pin Name	Function
TO-92S-3	SOT-23-3	DFN-2x2-3		
1	1	1	VCC	Power supply pin
2	3	3	GND	Ground pin
3	2	2	OUTPUT	Output pin

Functional Block Diagram



A (B)
 A for TO-92S-3
 B for SOT-23-3 and DFN-2x2-3

Figure 3. Functional Block Diagram of AH9248



High Sensitivity Micropower Omnipolar Hall-Effect Switch

AH9248

Ordering Information

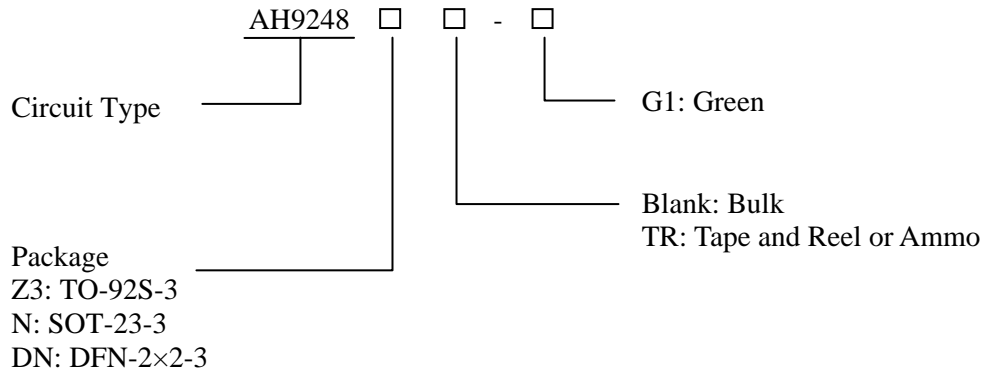

Package	Temperature Range	Part Number	Marking ID	Packing Type
TO-92S-3	-40 to 85°C	AH9248Z3-G1	9248	Bulk
		AH9248Z3TR-G1	9248	Ammo
SOT-23-3		AH9248NTR-G1	GL1	Tape & Reel
DFN-2×2-3		AH9248DNTR-G1	JA	Tape & Reel

BCD Semiconductor's Pb-free products, as designated with "G1" suffix in the part number, are RoHS compliant and green.

**High Sensitivity Micropower Omnipolar Hall-Effect Switch****AH9248****Absolute Maximum Ratings (T_A=25°C, Note 1)**

Parameter	Symbol	Value		Unit
Supply Voltage	V _{CC}	7		V
Supply Current (Fault)	I _{CC}	6		mA
Output Voltage	V _{OUT}	7		V
Output Current	I _{OUT}	2		mA
Magnetic Flux Density	B	Unlimited		Gauss
Power Dissipation	P _D	TO-92S-3	400	mW
		SOT-23-3	230	
		DFN-2×2-3	230	
Storage Temperature	T _{STG}	-55 to 150		°C
Junction Temperature	T _J	150		°C
ESD (Machine Model) (Note 2)	ESD	200		V

Note 1: Stresses greater than those listed under “Absolute Maximum Ratings” may cause permanent damage to the device. These are stress ratings only, and functional operation of the device at these or any other conditions beyond those indicated under “Recommended Operating Conditions” is not implied. Exposure to “Absolute Maximum Ratings” for extended periods may affect device reliability.

Note 2: Electronic semiconductor products are sensitive to Electro Static Discharge (ESD). Always observe Electro Static Discharge control procedures whenever handling semiconductor products.

Recommended Operating Conditions

Parameter	Symbol	Min	Max	Unit
Supply Voltage	V _{CC}	2.5	5.5	V
Operating Temperature	T _{OP}	-40	85	°C

**High Sensitivity Micropower Omnipolar Hall-Effect Switch****AH9248****Electrical Characteristics** $V_{CC}=3V$, $T_A=25^{\circ}C$, unless otherwise specified.

Parameter	Symbol	Conditions	Min	Typ	Max	Unit
Supply Voltage	V_{CC}	Operating	2.5	3	5.5	V
Supply Current	I_{AW}	Awake		2	4	mA
	I_{SL}	Sleep		6	10	μA
	I_{AVG}	Average		10	15	μA
Output Current	I_{OUT}				1.0	mA
Output Leakage Current	I_{LEAK}	$B < B_{RP} $		<0.1	1	μA
Saturation Voltage	V_{SAT}	$I_{OUT}=1.0mA$			0.4	V
Awake Mode Time	t_{AW}	Operating		150		μs
Sleep Mode Time	t_{SL}	Operating		90	120	ms
Duty Cycle	D			0.15		%
Chopper Frequency	f_C			15		kHz

Magnetic Characteristics (Note 3) $V_{CC}=3V$, $T_A=25^{\circ}C$, unless otherwise specified.

Parameter	Symbol	Conditions	Min	Typ	Max	Unit
Operating point	B_{OPS}	South pole to branded side $B > B_{OPS}, V_{OUT} = \text{low}(\text{output on})$		30	55	Gauss
	B_{OPN}	North pole to branded side $B > B_{OPN}, V_{OUT} = \text{low}(\text{output on})$	-55	-30		Gauss
Releasing Point	B_{RPS}	South pole to branded side $B < B_{RPS}, V_{OUT} = \text{high}(\text{output off})$	5	20		Gauss
	B_{RPN}	North pole to branded side $B < B_{RPN}, V_{OUT} = \text{high}(\text{output off})$		-20	-5	Gauss
Hysteresis	B_{HYS}	$ B_{OPX} - B_{RPX} $ (Note 4)		10		Gauss

Note 3: The specifications stated here are guaranteed by design. 1 Gauss=0.1mT

Note 4: B_{OPX} =operating point(output turns on); B_{RPX} =releasing point(output turns off)

Magnetic Characteristics (Continued)

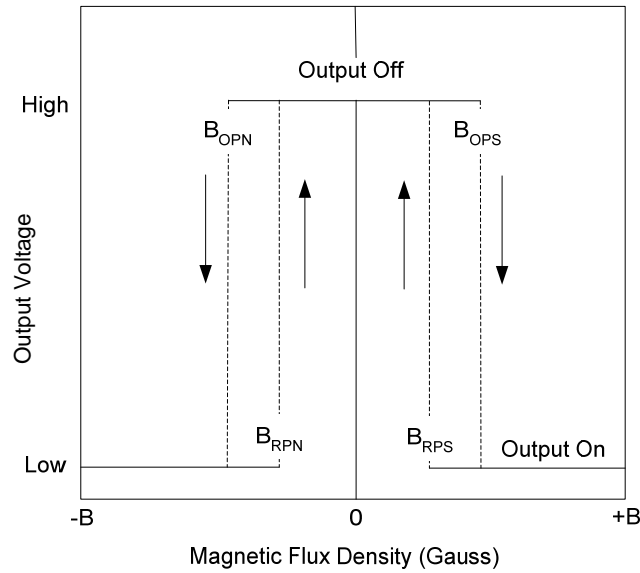

Figure 4. Output Voltage vs. Magnetic Flux Density

Test Conditions

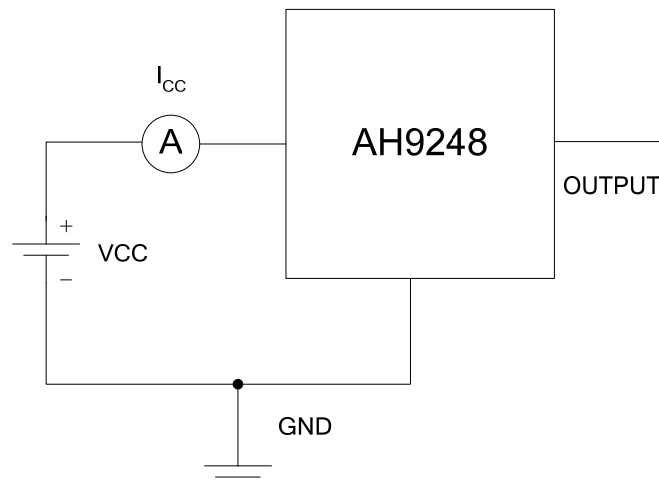

Figure 5. Average Supply Current (Note 5, 6)

Note 5: I_{CC} represents the average supply current. OUTPUT is open during measurement.

Note 6: The device is put under magnetic field with $B < B_{RP}$.

Test Conditions (Continued)

Figure 6. Output Saturation Voltage (Note 7, 8)

Note 7: The output saturation voltage V_{SAT} is measured at $V_{CC}=2.5V$ and $V_{CC}=5.5V$.

Note 8: The device is put under magnetic field with $B > B_{OP}$.

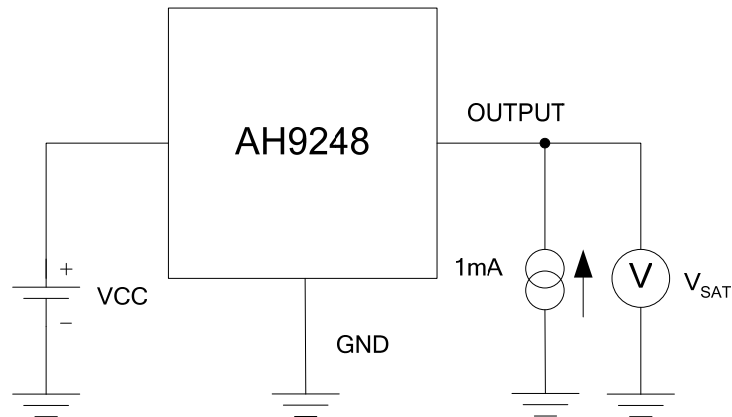
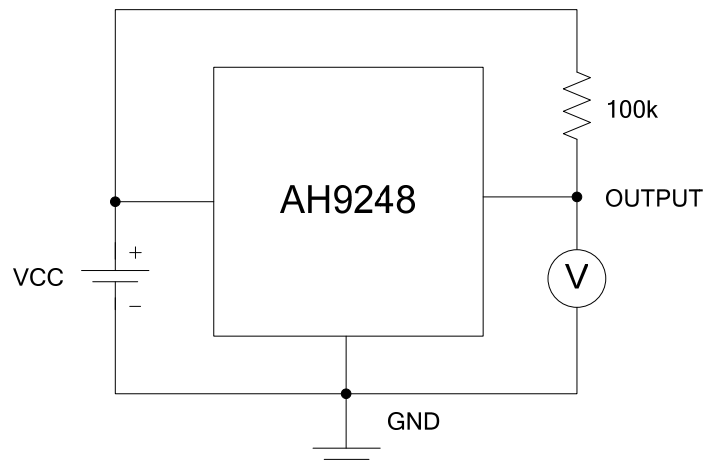

Figure 7. Magnetic Thresholds (Note 9, 10)

Note 9: B_{OP} is determined by putting the device under magnetic field swept from $B_{RP(min)}$ to $B_{OP(max)}$ until the output is switched on.

Note 10: B_{RP} is determined by putting the device under magnetic field swept from $B_{OP(max)}$ to $B_{RP(min)}$ until the output is switched off.

Typical Performance Characteristics

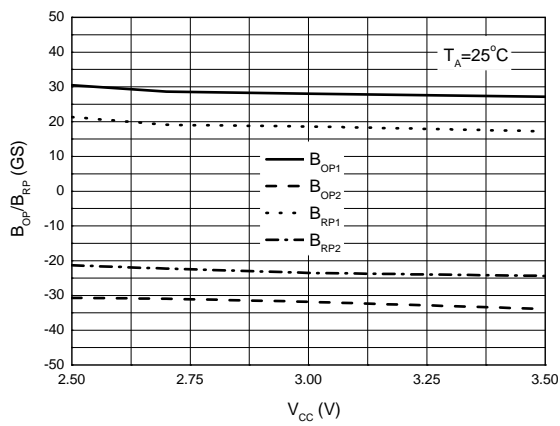

Figure 8. B_{OP}/B_{RP} vs. Supply Voltage

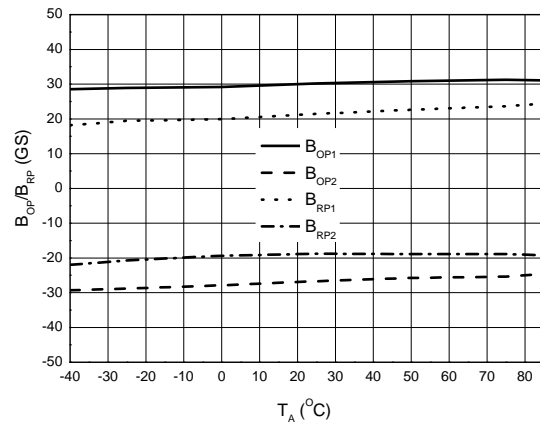

Figure 9. B_{OP}/B_{RP} vs. Ambient Temperature

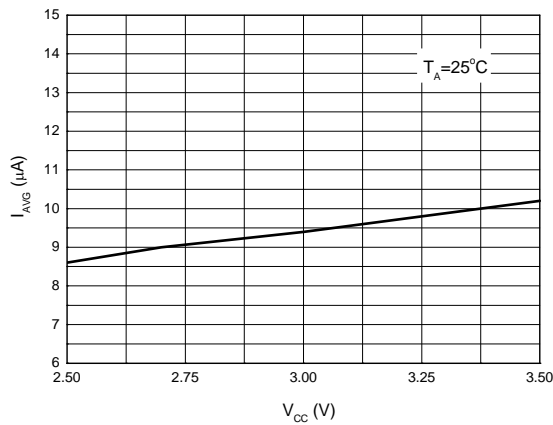

Figure 10. Average Supply Current vs. Supply Voltage

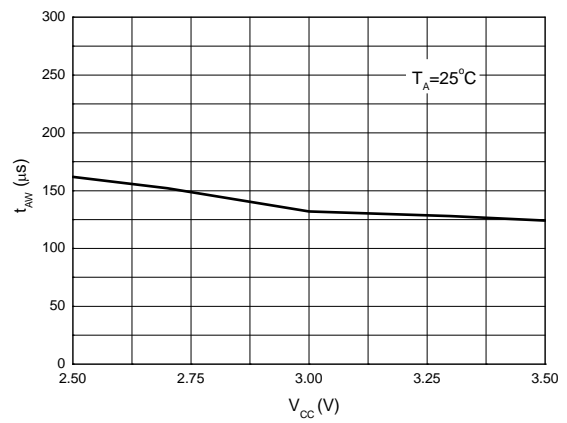

Figure 11. Awake Mode Time vs. Supply Voltage

Typical Performance Characteristics (Continued)

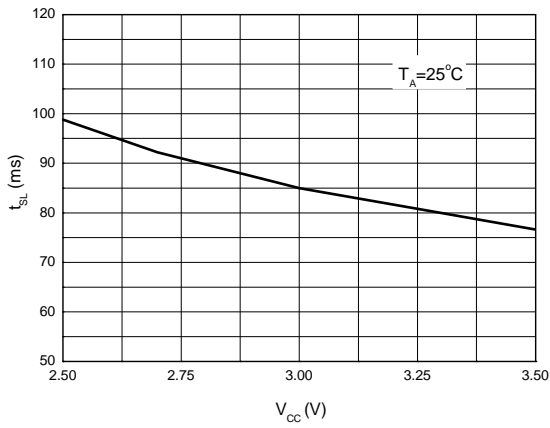

Figure 12. Sleep Mode Time vs. Supply Voltage

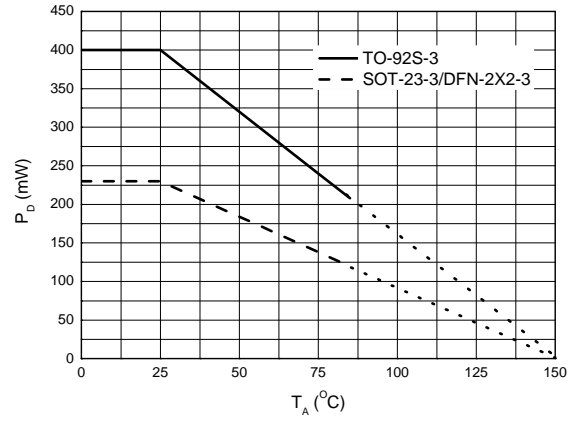

Figure 13. Power Dissipation vs. Ambient Temperature

Typical Application

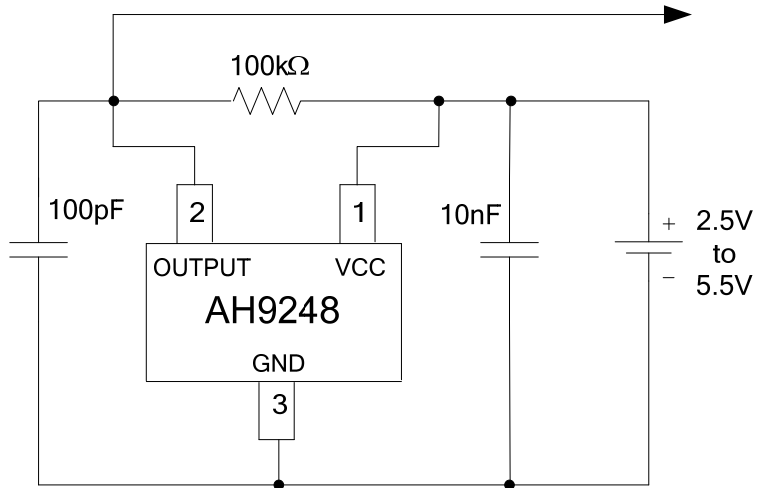
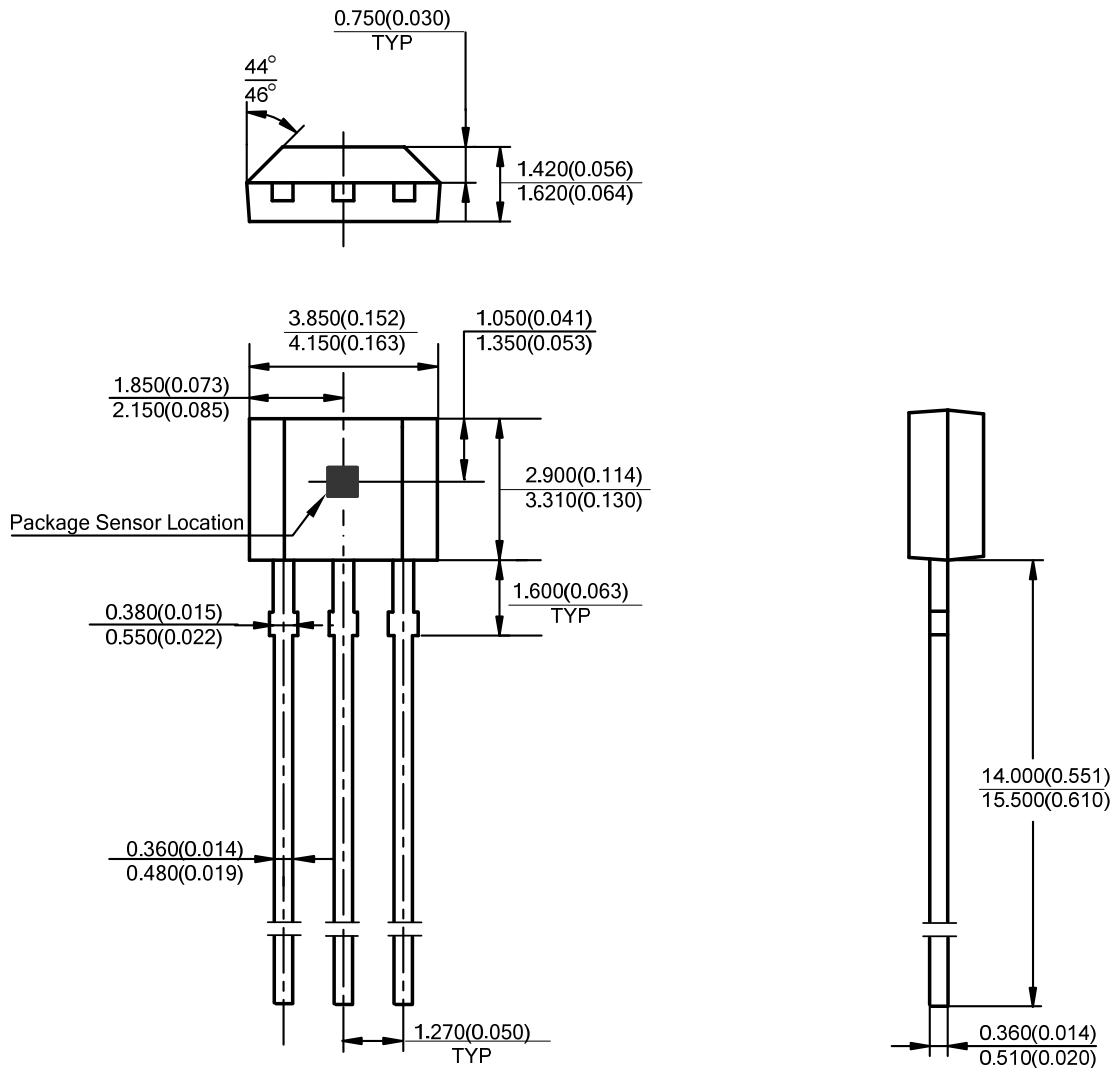

Figure 14. Typical Application of AH9248

Mechanical Dimensions

TO-92S-3

Unit: mm(inch)



Mechanical Dimensions (Continued)

SOT-23-3

Unit: mm(inch)

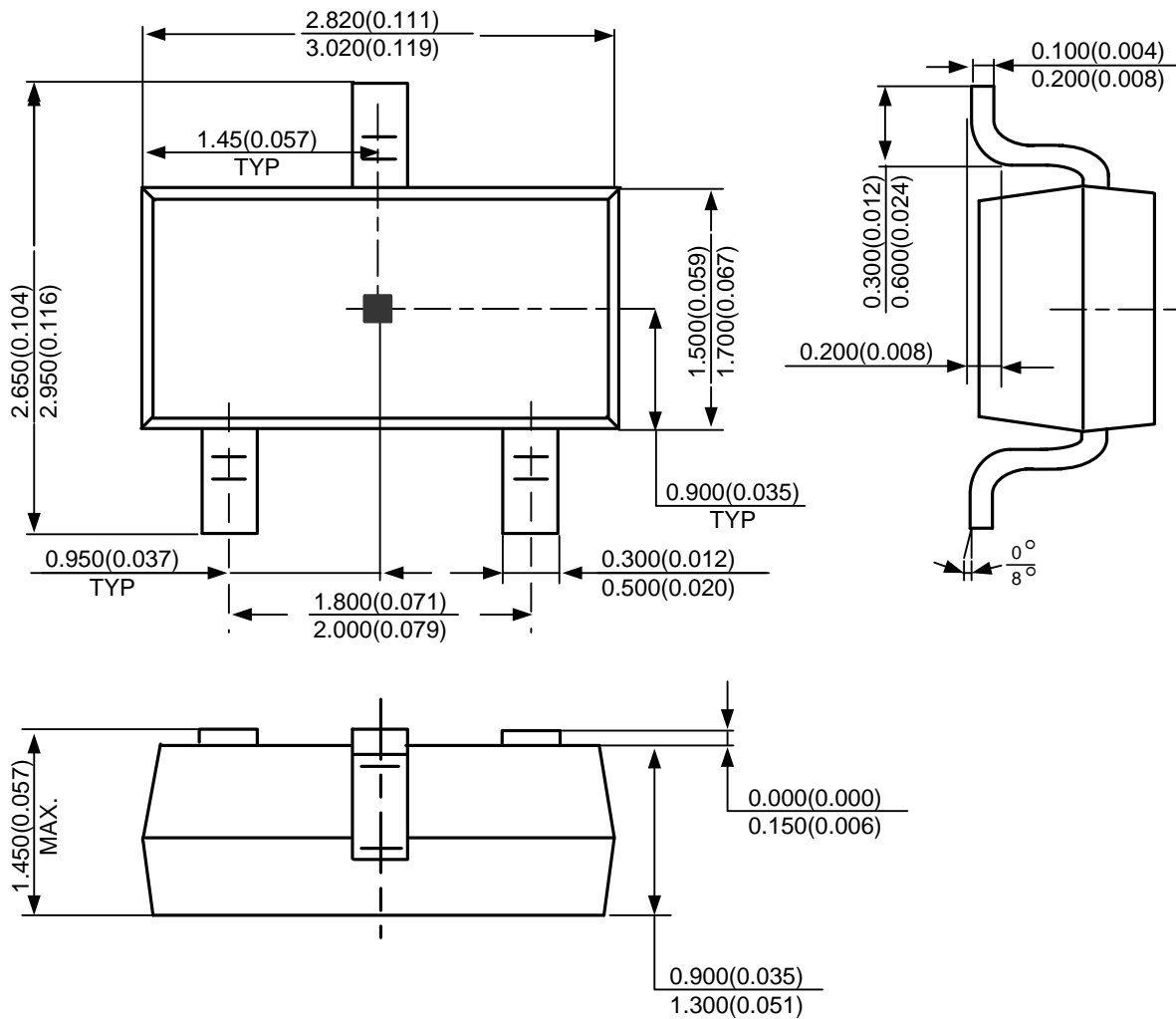

Mechanical Dimensions (Continued)

DFN-2x2-3

Unit: mm(inch)

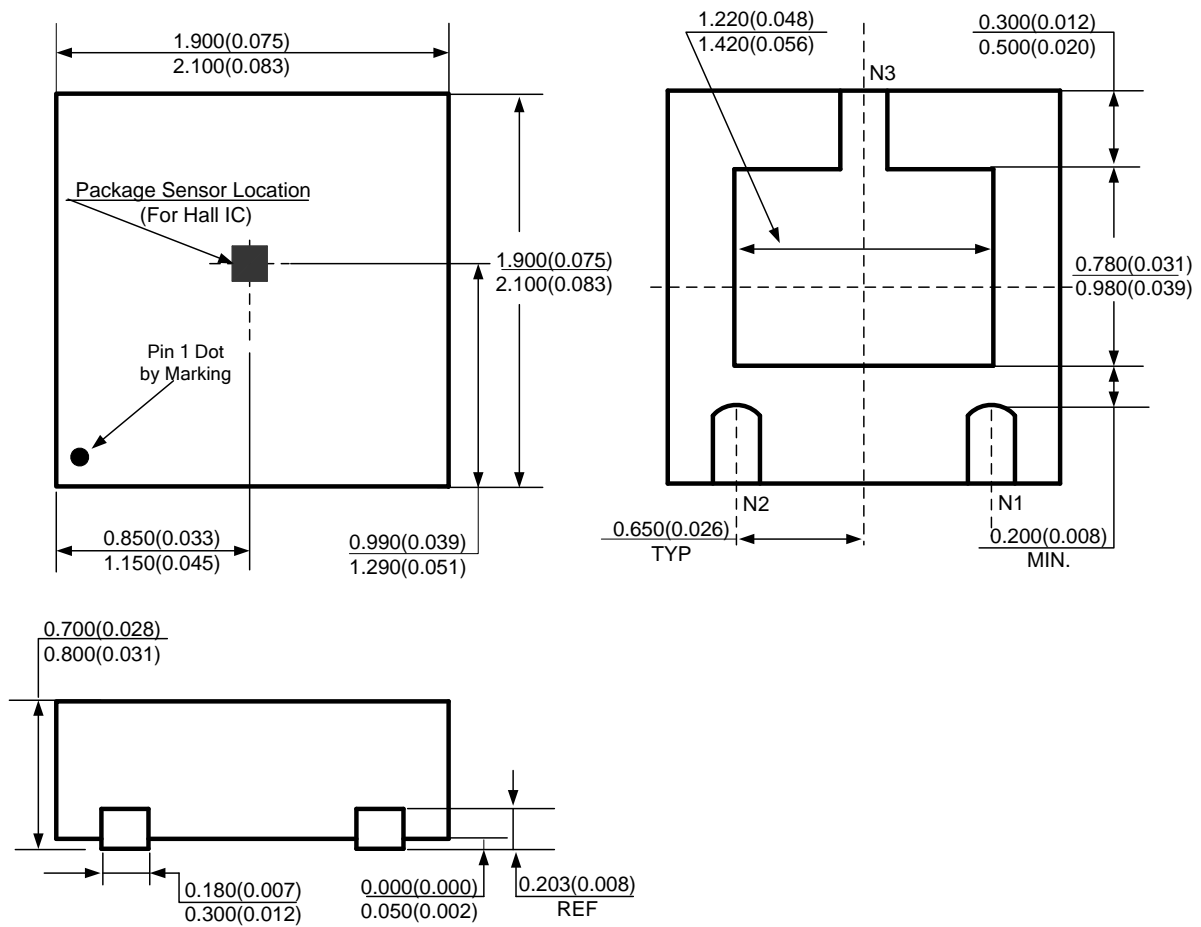



BCD Semiconductor Manufacturing Limited

<http://www.bcdsemi.com>

IMPORTANT NOTICE

BCD Semiconductor Manufacturing Limited reserves the right to make changes without further notice to any products or specifications herein. BCD Semiconductor Manufacturing Limited does not assume any responsibility for use of any its products for any particular purpose, nor does BCD Semiconductor Manufacturing Limited assume any liability arising out of the application or use of any its products or circuits. BCD Semiconductor Manufacturing Limited does not convey any license under its patent rights or other rights nor the rights of others.

MAIN SITE

- Headquarters

BCD Semiconductor Manufacturing Limited

No. 1600, Zi Xing Road, Shanghai ZiZhu Science-based Industrial Park, 200241, China
Tel: +86-21-24162266, Fax: +86-21-24162277

- Wafer Fab

Shanghai SIM-BCD Semiconductor Manufacturing Co., Ltd.

800 Yi Shan Road, Shanghai 200233, China
Tel: +86-21-6485 1491, Fax: +86-21-5450 0008

REGIONAL SALES OFFICE

Shenzhen Office

Shanghai SIM-BCD Semiconductor Manufacturing Co., Ltd., Shenzhen Office

Unit A Room 1203, Skyworth Bldg., Gaoxin Ave. 1.S., Nanshan District, Shenzhen, China
Tel: +86-755-8826 7951
Fax: +86-755-8826 7865

Taiwan Office

BCD Semiconductor (Taiwan) Company Limited

4F, 298-1, Rui Guang Road, Nei-Hu District, Taipei, Taiwan
Tel: +886-2-2656 2808
Fax: +886-2-2656 2806

USA Office

BCD Semiconductor Corp.

30920 Huntwood Ave. Hayward, CA 94544, USA
Tel : +1-510-324-2988
Fax: +1-510-324-2788