

## AHE28XXS SERIES

28V Input, Single Output

### HYBRID-HIGH RELIABILITY DC/DC CONVERTER

#### Description

The AHE28XXS Series of DC/DC converters feature high power density and an extended temperature range for use in military and industrial applications. Designed to MIL-STD-704D input requirements, these devices have nominal 28VDC inputs with +5V, +12V and +15V single outputs to satisfy a wide range of requirements. The circuit design incorporates a pulse width modulated push-pull topology operating in the feed-forward mode at a nominal switching frequency of 250KHz. Input to output isolation is achieved through the use of transformers in the forward and feedback circuits.

The advanced feedback design provides fast loop response for superior line and load transient characteristics and offers greater reliability and radiation tolerance than devices incorporating optical feedback circuits.

Three standard temperature grades are offered with screening options. Refer to Part Number section. They can be provided in a standard plug-in package for PC mounting or in a flanged package for more severe environments.

Manufactured in a facility fully qualified to MIL-PRF-38534, these converters are fabricated utilizing DSCC qualified processes. For available screening options, refer to device screening table in the data sheet. Variations in electrical, mechanical and screening can be accommodated. Extensive computer simulation using complex modeling enables rapid design modification to be provided. Contact IR Santa Clara with specific requirements.



#### Features

- 17V to 40VDC Input Range (28VDC Nominal)
- 5V, 12V and 15V Outputs Available
- Indefinite Short Circuit and Overload Protection
- 17 W/in<sup>3</sup> Power Density
- 15W and 20W Output Power Models
- Fast Loop Response for Superior Transient Characteristics
- Operating Temperature Range from -55°C to +125°C Available
- Popular Industry Standard Pin-Out
- Resistance Seam Welded Case for Superior Long Term Hermeticity
- Efficiencies up to 84%
- Shutdown from External Signal
- Military Screening
- 325,000 hour MTBF at 85°C (AUC)
- Standard Microcircuit Drawings Available

# AHE28XXS Series

## Specifications

International  
IRF Rectifier

$T_{CASE} = -55^{\circ}\text{C}$  to  $+85^{\circ}\text{C}$ ,  $V_{IN} = +28\text{V} \pm 5\%$  unless otherwise specified

Absolute Maximum Ratings		
Input Voltage <sup>1</sup>	-0.5V to +50VDC	
Power Output	Internally limited, 17.5W typ. for AHE2805S, 22.5W typ. for AHE2812S and AHE2815S	
Soldering Temperature	300°C for 10 seconds	
Temperature Range <sup>1</sup>	Operating Temperature	-55°C to +125°C
	Storage Case Temperature	-65°C to +135°C

Parameter	Conditions -55°C ≤ T <sub>c</sub> ≤ +85°C V <sub>in</sub> = 28 Vdc ±5%, C <sub>L</sub> = 0 Unless otherwise specified	AHE2805S			AHE2812S			AHE2815S			Units
		Min	Typ	Max	Min	Typ	Max	Min	Typ	Max	
Static Characteristic											
OUTPUT Voltage	V <sub>IN</sub> =17 to 40 VDC	4.90	5.00	5.10	11.76	12.00	12.24	14.70	15.00	15.30	VDC
Current	I <sub>OUT</sub> =0 to Full Load	0.0		3000	0.0		1667	0.0		1333	mADC
Ripple	Full Load, DC to 1MHz T <sub>CASE</sub> = 25°C, I <sub>OUT</sub> = 0		20	60		30	60		30	60	mVp-p
Accuracy Power <sup>1</sup>		4.95 15	5.00	5.05	11.88 20	12.00	12.12	14.85 20	15.00	15.15	VDC W
REGULATION Line Load	V <sub>IN</sub> = 17 to 40 VDC I <sub>OUT</sub> = to Full Load		±0.5 ±0.5	±1.0 ±1.0		±0.5 ±0.5	±1.0 ±1.0		±0.5 ±0.5	±1.0 ±1.0	%
INPUT Voltage Range <sup>4</sup> Current	Inhibited No Load	17	28	40	17	28	40	17	28.0	40	VDC mADC
Ripple Current	Full Load		8.0	18		8.0	18		8.0	18	mADC mV p-p
Efficiency	T <sub>CASE</sub> = +25°C Half Load to Full Load	80	82		79	83		80	84		%
Capacitive Load	No effect on performance	500			200			200			μF
Load fault power dissipation <sup>4</sup>				6.0			6.0			6.0	W
Isolation	Input to Output @ 500Vdc	100			100			100			MΩ
Dynamic Characteristic Step Load Changes Output Transient	50% Load 100% Load No Load 50% Load		±150 -300			±200 -400			±200 -400		mVpk mVpk
Recovery <sup>2</sup>	50% Load No Load 50% Load 100% Load No Load 50% Load 50% Load No Load		+300 25 500 7.0			+400 25 500 7.0			+400 25 500 7.0		mVpk μs μs msec
Step Line Changes Output Transient Recovery <sup>2</sup>	Input step 17 to 40VDC Input step 40 to 17VDC Input step 17 to 40VDC Input step 40 to 17VDC		+180 -600 400 400			+180 -600 400 400			+180 -600 400 400		mVpk mVpk μs μs
Turn-On Overshoot Delay <sup>3</sup>	V <sub>IN</sub> = 17 to 40VDC I <sub>OUT</sub> = 0 to Full load		0 8.0	500 14		300 8.0	600 14		300 8.0	500 14	mVpk ms
Load Fault Recovery <sup>4</sup>	V <sub>IN</sub> = 17 to 40VDC		8.0	14		8.0	14		8.0	14	ms
Weight	Standard Package Flange Package		55 58			55 58				55 58	g

### Notes to Specifications

- Above +85°C case temperature, derate output power linearly to 0 and maximum input voltage linearly to 42V at 115°C case.
- Recovery time is measured from the initiation of the transient to where V<sub>OUT</sub> has returned to within ±1.0% of V<sub>OUT</sub> at 50% load. See typical waveforms.
- Turn-on delay time measurement is for either an application of power at the input or a signal at the shutdown pin.
- For operation at 16VDC, derate output power by 33%.

$T_{CASE} = -55^{\circ}\text{C}$  to  $+105^{\circ}\text{C}$ ,  $V_{IN} = +28\text{V} \pm 5\%$  unless otherwise specified

Absolute Maximum Ratings		
Input Voltage <sup>5</sup>	-0.5V to +50VDC	
Power Output	Internally limited, 17.5W typ. for AHE2805S/ES, 22.5W typ. for AHE2812S/ES and AHE2815S/ES	
Soldering Temperature	300°C for 10 seconds	
Temperature Range <sup>1</sup>	Operating Temperature	-55°C to +125°C
	Storage Case Temperature	-65°C to +135°C

Parameter	Conditions -55°C ≤ Tc ≤ +105°C Vin = 28 Vdc ±5%, CL = 0 Unless otherwise specified	AHE2805S/ES			AHE2812S/ES			AHE2815S/ES			Units
		Min	Typ	Max	Min	Typ	Max	Min	Typ	Max	
Static Characteristic											
OUTPUT											
Voltage	V <sub>IN</sub> =17 to 40 VDC	4.90	5.00	5.10	11.76	12.00	12.24	14.70	15.00	15.30	VDC
Current	I <sub>OUT</sub> =0 to Full Load	0.0	20	3000	0.0	30	1667	0.0	30	1333	mADC
Ripple	Full Load, DC to 1MHz			60			60			60	mVp-p
Accuracy	T <sub>CASE</sub> = 25°C, I <sub>OUT</sub> = 0	4.95	5.00	5.05	11.88	12.00	12.12	14.85	15.00	15.15	VDC
Power <sup>1</sup>		15			20			20			W
REGULATION											
Line	V <sub>IN</sub> = 17 to 40 VDC		±0.5	±1.0		±0.5	±1.0		±0.5	±1.0	%
Load	I <sub>OUT</sub> = 0 to Full Load		±0.5	±1.0		±0.5	±1.0		±0.5	±1.0	%
INPUT											
Voltage Range <sup>4</sup>		17	28	40	17	28	40	17	28	40	VDC
Current	Inhibited		8.0	18		8.0	18		8.0	18	mADC
	No Load			35			35			35	mADC
Ripple Current	Full Load		20	50		25	50		25	50	mV p-p
Efficiency	T <sub>CASE</sub> = +25°C Half load to Full load	78	82		79	83		80	84		%
Capacitive Load	No effect on performance	500			200			200			μF
Load fault power dissipation <sup>4</sup>				6.0			6.0			6.0	W
Isolation	Input to Output @ 500Vdc	100			100			100			MΩ
Dynamic Characteristic											
Step Load Changes											
Output Transient	50% Load 100% Load		±150			±200			±200		mVpk
	No Load 50% Load		-300			-400			-400		mVpk
	50% Load No Load		+300			+400			+400		mVpk
Recovery <sup>2</sup>	50% Load 100% Load		25			25			25		μs
	No Load 50% Load		500			500			500		μs
	50% Load No Load		7.0			7.0			7.0		ms
Step Line Changes											
Output Transient	Input step 17 to 40VDC		+180			+180			+180		mVpk
	Input step 40 to 17VDC		-600			-600			-600		mVpk
Recovery <sup>2</sup>	Input step 17 to 40VDC		400			400			400		μs
	Input step 40 to 17VDC		400			400			400		μs
TURN -ON											
Overshoot	V <sub>IN</sub> = 17 to 40VDC		0	500		300	600		300	750	mVpk
Delay <sup>3</sup>	I <sub>OUT</sub> = 0 to Full Load		8.0	14		8.0	14		8.0	14	ms
Load Fault Recovery <sup>4</sup>	V <sub>IN</sub> = 17 to 40VDC		8.0	14		8.0	14		8.0	14	ms
Weight	Standard Package		60			60			60		g
	Flange Package		65			65			65		g

**Notes to Specifications**

- Above +105°C case temperature, derate output power linearly to 0 at 125°C case.
- Recovery time is measured from the initiation of the transient to where V<sub>OUT</sub> has returned to within ±1.0% of V<sub>OUT</sub> at 50% load. See typical waveforms.
- Turn-on delay time measurement is for either an application of power at the input or a signal at the shutdown pin.
- For operation at 16VDC, derate output power by 33%.
- Above +85°C case temperature, derate maximum input voltage linearly to 33V at +125°C case.

# AHE28XXS Series

## Specifications

$T_{CASE} = -55^{\circ}\text{C}$  to  $+105^{\circ}\text{C}$ ,  $V_{IN} = +28\text{V} \pm 5\%$  unless otherwise specified

Absolute Maximum Ratings		
Input Voltage <sup>1</sup>	-0.5V to +50VDC	
Power Output	Internally limited, 17.5W typ. for AHE2805S/HB & CH, 22.5W typ. for AHE281XS/HB & CH	
Soldering Temperature	300°C for 10 seconds	
Temperature Range <sup>1</sup>	Operating Temperature	-55°C to +125°C
	Storage Case Temperature	-65°C to +135°C

Parameter	Conditions -55°C ≤ T <sub>C</sub> ≤ +125°C V <sub>IN</sub> = 28 Vdc ±5%, C <sub>L</sub> = 0 Unless otherwise specified	AHE2805S/HB&CH			AHE2812S/HB&CH			AHE2815S/HB&CH			Units
		Min	Typ	Max	Min	Typ	Max	Min	Typ	Max	
Static Characteristic											
OUTPUT Voltage	V <sub>IN</sub> =17 to 40 VDC I <sub>OUT</sub> =0 to Full Load Full Load, DC to 1MHz T <sub>CASE</sub> = 25°C, I <sub>OUT</sub> = 0	4.90	5.00	5.10	11.76	12.00	12.24	14.70	15.00	15.30	VDC
OUTPUT Current		0.0		3000	0.0		1667	0.0		1333	mADC
OUTPUT Ripple				20	60		30		30	60	mVp-p
Accuracy Power <sup>1</sup>		4.95	5.00	5.05	11.88	12.00	12.12	14.85	15.00	15.15	VDC W
REGULATION Line	V <sub>IN</sub> = 17 to 40 VDC T <sub>CASE</sub> = 25°C			5.0			30			35	mV
REGULATION Load	I <sub>OUT</sub> = 0 to Full Load	10		50	50		120	50		150	
INPUT Voltage Range <sup>4</sup>	Inhibited No Load Full Load	17	28	40	17	28	40	17	28	40	VDC
INPUT Current			8.0	18		8.0	18		8.0	18	mADC
INPUT Ripple Current				20	50		25	50		25	50
Efficiency	T <sub>CASE</sub> = +25°C	80	82		80	83		80	84		%
Capacitive Load	No effect on performance	500	1000		200	1000		200	1000		μF
Load fault power dissipation <sup>5</sup>	Short Circuit T <sub>C</sub> = 25°C Overload T <sub>C</sub> = 25°C			4.5 6.0			4.5 6.0			4.5 6.0	W
Isolation	Input to Output @ 500Vdc	100			100			100			MΩ
Dynamic Characteristic Step Load Changes	50% Load 100% Load No Load 50% Load 50% Load No Load 50% Load 100% Load No Load 50% Load 50% Load No Load		±150	±300		±200	±300		±200	±300	mVpk
Transient			-300	-500		-400	-500		-400	-500	mVpk
Recovery <sup>2</sup>			+300	+500		+400	+500		+400	+500	mVpk
Recovery <sup>2</sup>			25	70		25	70		25	70	μs
Recovery <sup>2</sup>			100	200		500	1500		500	1500	μs
Recovery <sup>2</sup>				5.0			5.0			5.0	ms
Step Line Changes	Input step 17 to 40VDC Input step 40 to 17VDC Input step 17 to 40VDC Input step 40 to 17VDC		+180	+300		+180	+500		+180	+500	mVpk
Transient			-600	1000		-600	-1500		-600	-1500	mVpk
Recovery <sup>2</sup>			400	800		400	800		400	800	μs
Recovery <sup>2</sup>			400	800		400	800		400	800	μs
TURN -ON Overshoot	V <sub>IN</sub> = 17 to 40VDC		0	550		300	600		300	500	mVpk
Delay <sup>3</sup>	I <sub>OUT</sub> = 0 to Full Load		8.0	10		8.0	10		8.0	10	ms
Load Fault Recovery <sup>4</sup>	V <sub>IN</sub> = 17 to 40VDC		8.0	10		8.0	10		8.0	10	ms
Weight	Standard Package		55			55				55	g
	Flange Package		58			58				58	

### Notes to Specifications

- Above +125°C case temperature, derate output power linearly to 0 at 135°C case.
- Recovery time is measured from the initiation of the transient to where V<sub>OUT</sub> has returned to within ±1.0% of V<sub>OUT</sub> at 50% load. See typical waveforms.
- Turn-on delay time measurement is for either an application of power at the input or a signal at the shutdown pin.
- For operation at 16VDC, derate output power by 33%.
- An overload is that condition with a load in excess of the rated load but less than that necessary to trigger the short circuit protection and is the condition of maximum power dissipation.

Block Diagram

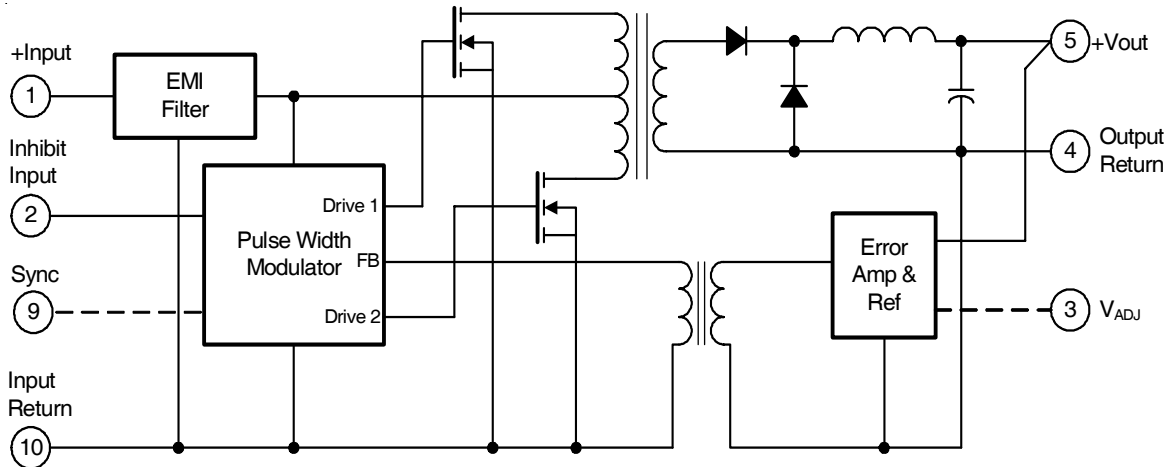

Application Information

Inhibit Function

Connecting the inhibit input (Pin 2) to input common (Pin 10) will cause the converter to shut down. It is recommended that the inhibit pin be driven by an open collector device capable of sinking at least 400µA of current. The open circuit voltage of the inhibit input is 11.5 ± 1.0VDC.

EMI Filter

An EMI filter (AFC461), available as an option, will reduce the input ripple current to levels below the limits imposed by MIL-STD-461B CEO.

Output Voltage Adjustment (AHE2805 only)

The output voltage of the AHE2805S converter can be adjusted upward by connecting an appropriate resistor between Output Adjust (Pin 3) and Output Common (Pin 4) as shown in Table 1 below.

Table 1 Output adjustment resistor values

Resistance Pin 3 to 4 (Ω)	Output Voltage Increases (%)
None	0
390K	+1%
145K	+2%
63K	+3%
22K	+4%
0	+5%

Device Synchronization

Whenever multiple DC/DC converters are utilized in a single system, significant low frequency noise may be generated due to slight difference in the switching frequencies of the converters (beat frequency noise). Because of the low frequency nature of this noise (typically less than 10KHz), it is difficult to filter out and may interfere with proper operation of sensitive systems (communications, radar or telemetry). International Rectifier offers an option, which provides synchronization of multiple AHE/ATW/ATO type converters, thus eliminating this type of noise.

Typical Synchronization Connection

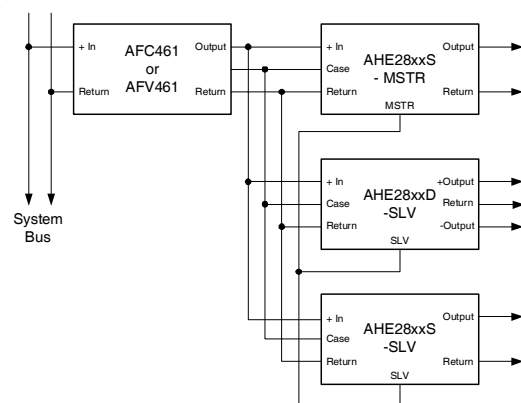

## AHE28XXS Series

International  
**IR** Rectifier

To take advantage of this capability, the system designer must assign one of the converters as the master. Then, by definition, the remaining converters become slaves and will operate at the masters' switching frequency.

The user should be aware that the synchronization system is fail-safe; that is, the slaves will continue operating should the master frequency be interrupted for any reason. The layout must be such that the synchronization output (pin9) of the master device is connected to the synchronization input (pin 9) of each slave device. It is advisable to keep this run short to minimize the possibility of radiating the 250KHz switching frequency.

The appropriate parts must be ordered to utilize this feature. After selecting the converters required for the system, a MSTR suffix is added for the master converter part number and a SLV suffix is added for slave part number. See Part Number section.

**Standard Microcircuit Drawing Equivalence Table**

<b>Standard Microcircuit Drawing Number</b>	<b>Vendor Cage Code</b>	<b>IR Standard Part Number</b>
5962-89683	52467	AHE2805S
5962-91580	52467	AHE2812S
5962-91625	52467	AHE2815S

**Mechanical Outlines**

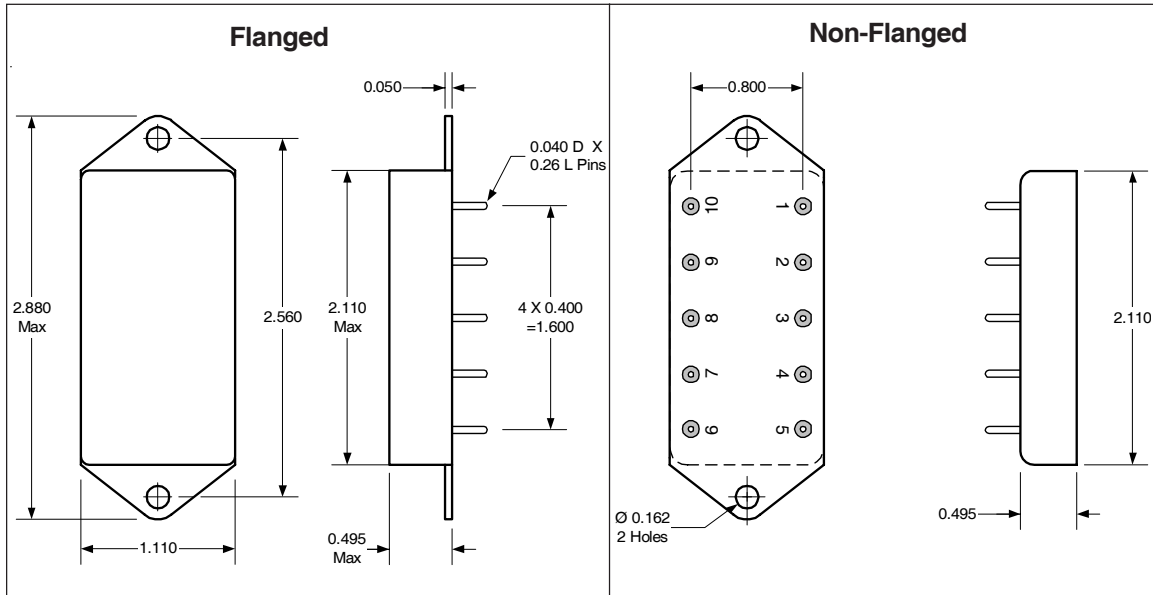

**Pin Designation**

Pin #	Designation
1	+ Input
2	Inhibit Input
3	Output Adjust *
4	Output Return
5	+ Output
6	NC
7	NC
8	Case Ground
9	NC or Sync.
10	Input Return

\* AHE2805S only. AHE2812S / 2815S have NC on Pin 3

Device Screening

Requirement	MIL-STD-883 Method	No Suffix	ES ②	HB	CH
Temperature Range	—	-20°C to +85°C	-55°C to +125°C ③	-55°C to +125°C	-55°C to +125°C
Element Evaluation	MIL-PRF-38534	N/A	N/A	N/A	Class H
Non-Destructive Bond Pull	2023	N/A	N/A	N/A	N/A
Internal Visual	2017	①	Yes	Yes	Yes
Temperature Cycle	1010	N/A	Cond B	Cond C	Cond C
Constant Acceleration	2001, Y1 Axis	N/A	500 Gs	3000 Gs	3000 Gs
PIND	2020	N/A	N/A	N/A	N/A
Burn-In	1015	N/A	48 hrs@hi temp	160 hrs@125°C	160 hrs@125°C
Final Electrical ( Group A )	MIL-PRF-38534 & Specification	25°C	25°C ②	-55°C, +25°C, +125°C	-55°C, +25°C, +125°C
PDA	MIL-PRF-38534	N/A	N/A	N/A	10%
Seal, Fine and Gross	1014	Cond A	Cond A, C	Cond A, C	Cond A, C
Radiographic	2012	N/A	N/A	N/A	N/A
External Visual	2009	①	Yes	Yes	Yes

Notes:

- ① Best commercial practice
- ② Sample tests at low and high temperatures
- ③ -55°C to +105°C for AHE, ATO, ATW

Part Numbering

