

AC/DC Current transducer AHR-B420

The transducer for the electronic measurement of DC & distorted AC waveform currents, with galvanic isolation between the primary circuit (power) and the secondary circuit (measurement).

True r.m.s. 4-20 mA current output.



$I_{PN} = 500 \dots 2000 \text{ A}$

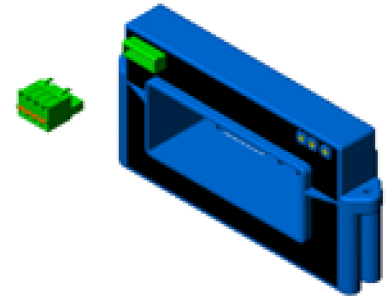

Electrical data

Primary nominal DC & AC current	Primary AC current max. peak value ¹⁾	Output current	Type
I_{PN} (At rms)	I_p (A)	I_{OUT} (mA DC)	
500	2000	4-20	AHR 500 B420
800	2500	4-20	AHR 800 B420
1000	2000	4-20	AHR 1000 B420
1500	2500	4-20	AHR 1500 B420
2000	3000	4-20	AHR 2000 B420

R_L	Load resistance	< 300	Ω
V_C	Supply voltage	+ 20 .. 50	V DC
I_C	Current consumption	30 mA + I_{OUT}	
I_{SL}	Output current limitation	< 25	mA
\hat{I}_P	Overload capability (Ampere Turns)	30000	At

Performance data

X	Accuracy @ I_{PN} , $T_A = 25^\circ\text{C}$ (excluding offset)	< ± 1	% of I_{PN}
e_L	Linearity error (1% of $I_{PN} \dots \pm I_{PN}$)	< ± 1.0	% of I_{PN}
I_{OE}	Electrical offset current, $T_A = 25^\circ\text{C}$	4 mA	$\leq \pm 1.0$ % of I_{PN}
TCI_{OE}	Temperature coefficient of I_{OE} (0 .. + 60 °C)	± 3.2	$\mu\text{A/K}$
	(- 40..+ 70 °C)	± 6.4	$\mu\text{A/K}$
TCG	Temperature coefficient of G (% of reading)	± 0.15	%/K
t_r	Response time to 90% of I_{PN} step	< 150	ms
BW	Frequency bandwidth (± 1 dB)	DC 20 .. 6000	Hz

General data

T_A	Ambient operating temperature	- 40 .. + 70	$^\circ\text{C}$
T_S	Ambient storage temperature	- 40 .. + 85	$^\circ\text{C}$
m	Mass	260	g
IPxx	Protection degree	IP20	

Features

- DC + distorted AC waveform currents measurement
- True r.m.s. output
- Busbar or panel mounting
- Split core type
- Insulated plastic case recognized according to UL94-V0.

Advantages

- High isolation between primary and secondary circuits
- Eliminates insertion loss
- Easy installation.

Applications

- **AC power supplies or Motors:**
True r.m.s. current sensing - the most accurate way to monitor power supply or motor input power
- **VFD Controlled Loads:**
VFD output current monitoring to indicate how the motor and the attached load are operating
- **SCRs or Switch-mode Rectifiers:**
Accurate measurement of output current
- **Renewable Energy Installations or Backup Batteries:**
Continuous condition monitoring allowing automatic failure detection/anticipation.

Note : ¹⁾ The max. peak AC current is the highest peak level of the primary signal that is taken into account for accurate true r.m.s. calculation. Yet the device is designed for maximum continuous true r.m.s. value equal to I_{PN} , whereas the output is limited by the above specified output limitation.

Current Transducer AHR-B420

Isolation characteristics

V_b	Rated isolation voltage rms with IEC 61010-1 according to the 61326 standards and following conditions: - Double insulation - Over voltage category CAT III - Pollution degree PD2 - Heterogeneous field	600	V
V_d	Rms voltage for AC isolation test, 50Hz, 1min	5.2	kV
dCp	Creepage distance	11	mm
dCl	Clearance distance	11	mm
CTI	Comparative tracking index (Group I)	600	

Output polarity with DC input

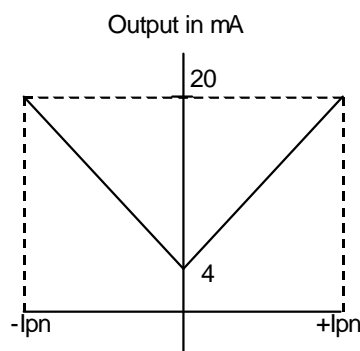

Safety



This transducer must be used in electric/electronic equipment with respect to applicable standards and safety requirements in accordance with the manufacturer's operating instructions.

Installation and maintenance should be done with main power supply disconnected.

The operator must have an accreditation to install this material.



Caution! Risk of electrical shock

When operating the transducer, certain parts of the module can carry hazardous voltage (e.g. primary conductor).

Ignoring this warning can lead to injury and/or cause serious damage.

The user must take care of all protection guarantee against electrical shock.

This transducer is a built-in device, whose conducting parts must be inaccessible after installation. A protective housing or additional shield could be used.

Dimensions AHR-B420 (in mm. 1 mm = 0.0394 inch)

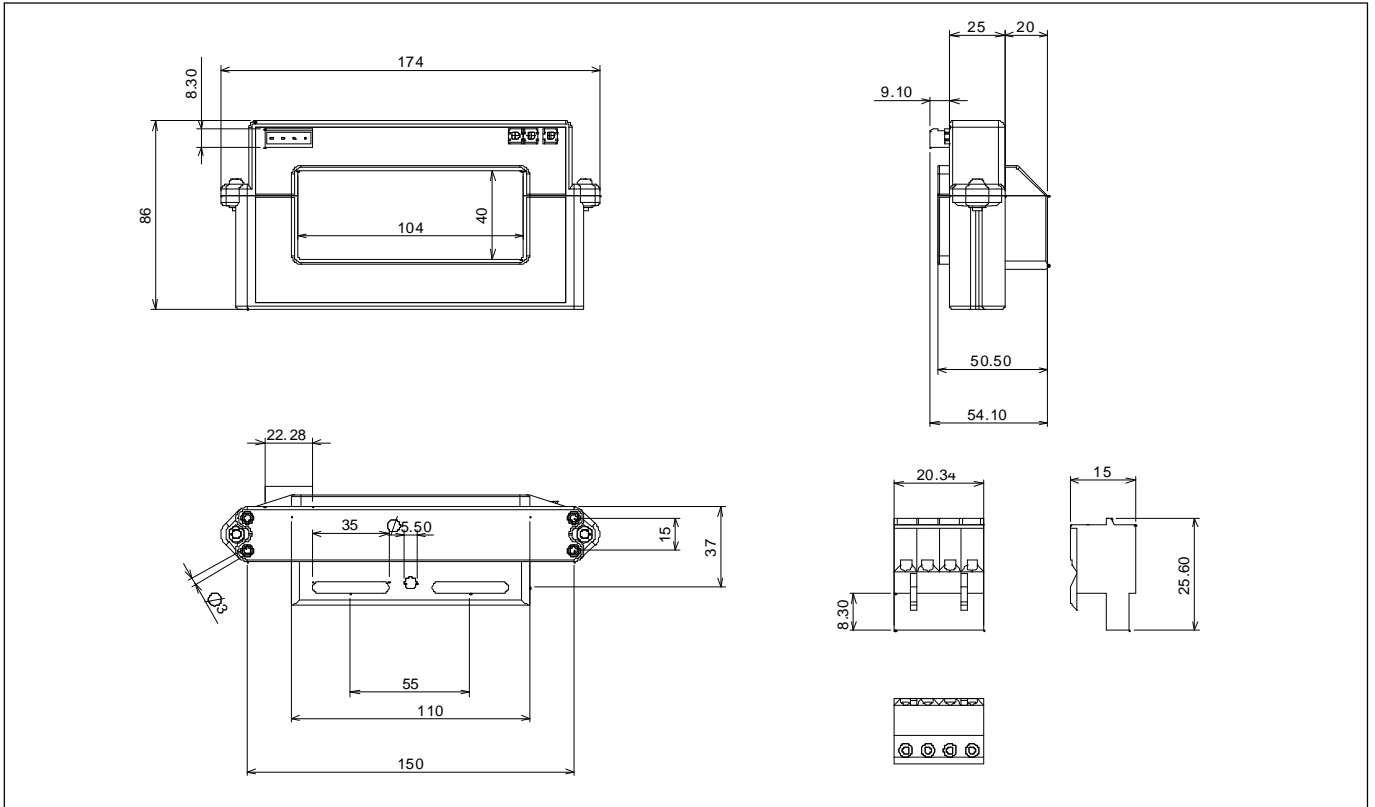

Connections

- Wires up to 2 mm \varnothing
- Female connector provided (screw terminals)

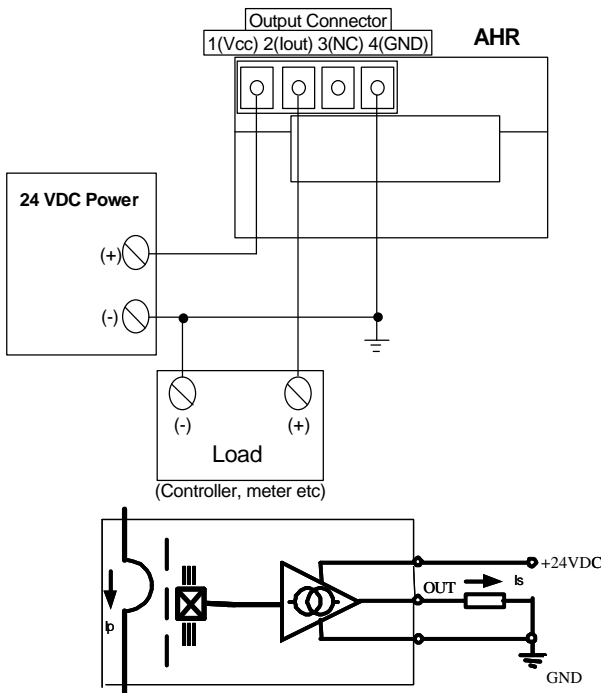

Mechanical characteristics

- General tolerance ± 1 mm
- Primary aperture 104 x 40 mm
- Busbar fastening 1 hole $\varnothing 5.5$ mm & 2 slots 5.5 x 30 mm
- Panel mounting 4 holes $\varnothing 3.2$ mm
- Distance between holes axes 15 x 150 mm

Remarks

- The return busbar and primary conductor elbow must be located at least at a distance of 2.5 x the window length away from the transducer case.
- The temperature of the primary busbar can not exceed 90°C.
- Dynamic performances are the best with a primary busbar completely filling the primary aperture.
- This is a standard model. For different versions (supply voltages, different outputs, bidirectional measurements...), please contact us.