

1A Ultra Low Dropout Linear Regulator

FEATURES

- Guaranteed 1A Output Current.
- Low Ground Current
- Wide Operating Voltage Ranges: 2.3V to 5.5V.
- 0.5 μ A Quiescent Current in Shutdown.
- Fixed Output Voltage of 1.5V, 1.8V, 2.5V, 3.3V
- Fast Transient Response
- Current Limit and Thermal Limit
- Available in SOT-223, TO-220, TO-263 TO-263-5, TO-252 and TO-252-5 Packages

APPLICATIONS

- Mother Board and Notebook
- Gigabit Ethernet Switch
- Microprocessor Power Systems
- Network Cards
- Peripheral Cards
- GTL, GTL+, BTL, and SSTL Bus Terminators
- DSPs Power Supplies
- Battery Powered Applications

DESCRIPTION

The AIC1187 is an ultra low dropout and high performance linear regulator with 1A output current capability. The output voltage is fixed 1.5V, 1.8V, 2.5V and 3.3V. Its low dropout voltage and fast transient response make it ideal for low voltage microprocessor applications.

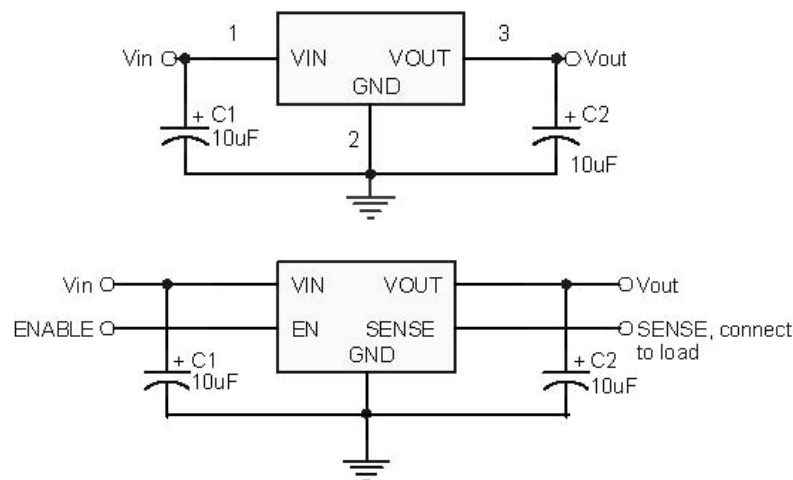

In addition, the enable pin reduces power dissipation at shutdown mode. Current limit and thermal protection provide protection against any overload condition that would create excessive junction temperatures.

TYPICAL APPLICATION CIRCUIT

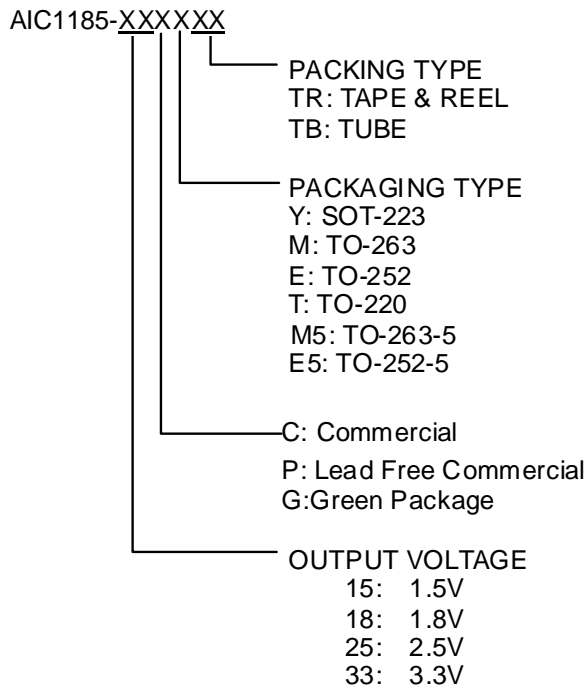

■ ORDERING INFORMATION

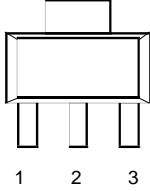
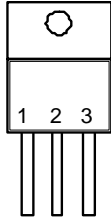
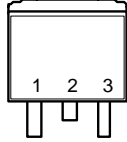
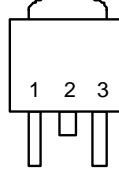
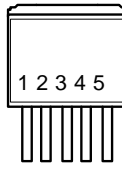

PIN CONFIGURATION	
SOT-223 TOP VIEW 1: VIN 2: GND (TAB) 3: VOUT	
TO-220 FRONT VIEW 1: VIN 2: GND (TAB) 3: VOUT	
TO-263 TOP VIEW 1: VIN 2: GND (TAB) 3: VOUT	
TO-252 TOP VIEW 1: VIN 2: GND (TAB) 3: VOUT	
TO-263-5 TOP VIEW 1: VIN 2: EN 3: GND (TAB) 4: SENSE 5: VOUT	
TO-252-5 TOP VIEW 1: VIN 2: EN 3: GND (TAB) 4: SENSE 5: VOUT	

Example: AIC1187-15CYTR
 → 1.5V version in SOT-223
 Package & Taping & Reel
 Packing Type
 AIC1187-15PYTR
 → 1.5V Version, in SOT-223 Lead
 Free Package & Tape & Reel
 Packing Type
 AIC1187-15GYTR
 → 1.5V Version, in SOT-223 Green
 Package & Tape & Reel Packing
 Type

■ **ABSOLUTE MAXIMUM RATINGS**

Supply Voltage	5.5V
Storage Temperature Range	-65°C~150°C
Operating Temperature Range	-40°C~85°C
Junction Temperature	125°C
Lead Temperature (Soldering, 10 sec)	260°C
Thermal Resistance (Junction to Case) SOT-220	3°C /W
SOT-223	15°C /W
TO-263, TO-263-5	6°C /W
TO-252, TO252-5	12.5°C /W
Thermal Resistance Junction to Ambient SOT-220	50°C /W
(Assume no ambient airflow, no heat sink) SOT-223	130°C /W
TO-263, TO-263-5	60°C /W
TO-252, TO-252-5	100°C /W

Absolute Maximum Ratings are those values beyond which the life of a device may be impaired.

■ **TEST CIRCUIT**

Refer to “TYPICAL APPLICATION CIRCUIT”.

■ ELECTRICAL CHARACTERISTICS
($V_{IN} = V_O + 0.7V$, $I_{OUT} = 10mA$, $V_{EN} = V_{IN}$, $T_A=25^{\circ}C$, unless otherwise specified) (Note 1)

PARAMETER	TEST CONDITIONS	SYMBOL	MIN.	TYP.	MAX.	UNIT
Input Voltage Range		V_{IN}	2.25		5.5	V
Output Voltage Tolerance			-1.5		+1.5	%
Line Regulation	$V_{IN} = V_{OUT} + V_{Drop(max)}$ to 5.5V	ΔV_{LIR}		0.3	1	%
Load Regulation	$V_{IN} = V_{OUT} + 0.7$	ΔV_{LOR}		30	60	mV
Dropout Voltage	$I_{OUT}=1A$	V_{DROP}		550	700	mV
					750	
Quiescent Current		I_Q		1	2	mA
Shutdown Supply Current	$V_{EN}=0V$	I_{SD}		0.5	5	μA
Output Current Limit	$V_{IN}=V_{OUT} + 0.7$	I_{IL}	2	5		A
Shutdown Terminal Specifications						
EN Pin Shutdown Threshold	Output=H	V_{EN}	1.2			V
	Output=L				0.4	
EN Pin Current	$V_{EN}= V_{IN}$	I_{EN}		0.1		nA
FLG Pin Leakage Current				1		nA
FLG Pin Sink Current	$V_{FLG}=0.5V$		2			mA
Thermal Protection						
Thermal Shutdown Temperature	Guaranteed by design	T_{SD}		170		$^{\circ}C$
Thermal Shutdown Hysteresis	Guaranteed by design	T_{HYST}		10		$^{\circ}C$

Note 1: Specifications are production tested at $T_A=25^{\circ}C$. Specifications over the $-40^{\circ}C$ to $85^{\circ}C$ operating temperature range are assured by design, characterization and correlation with Statistical Quality Controls (SQC).

■ TYPICAL PERFORMANCE CHARACTERISTICS

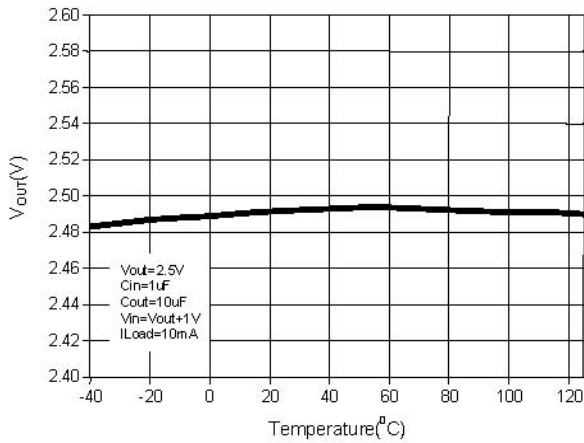

Output Voltage vs. Temperature

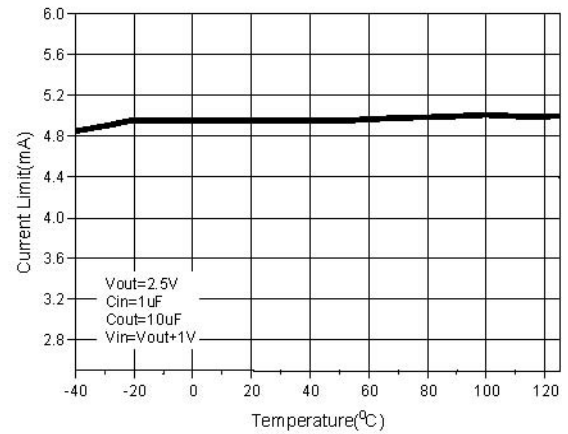

Current Limit vs. Temperature

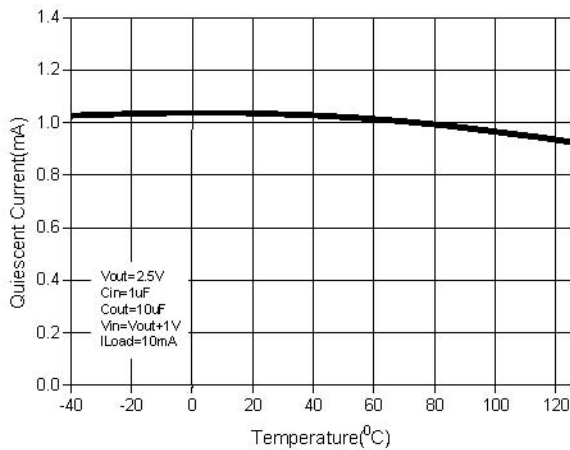

Quiescent Current vs. Temperature

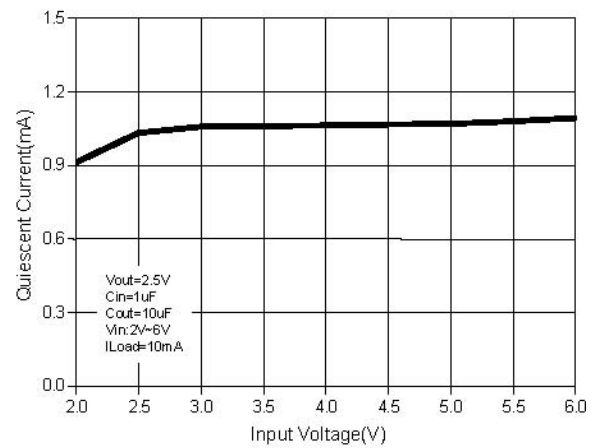

Quiescent Current vs. Input Voltage

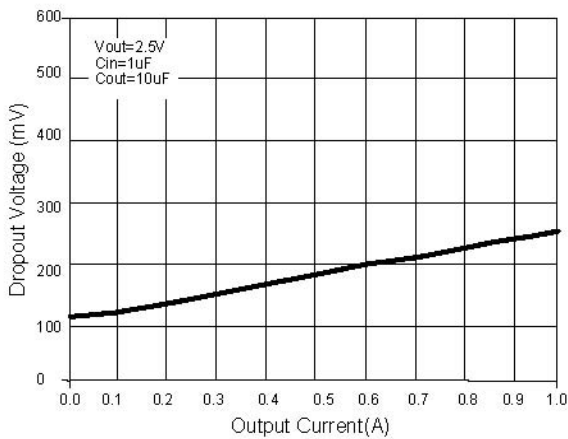

Dropout Voltage vs. I_{OUT} Current

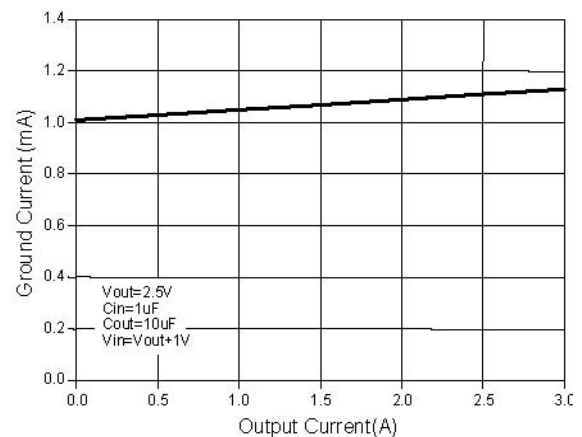

Ground Current vs. I_{OUT} Current

■ BLOCK DIAGRAM

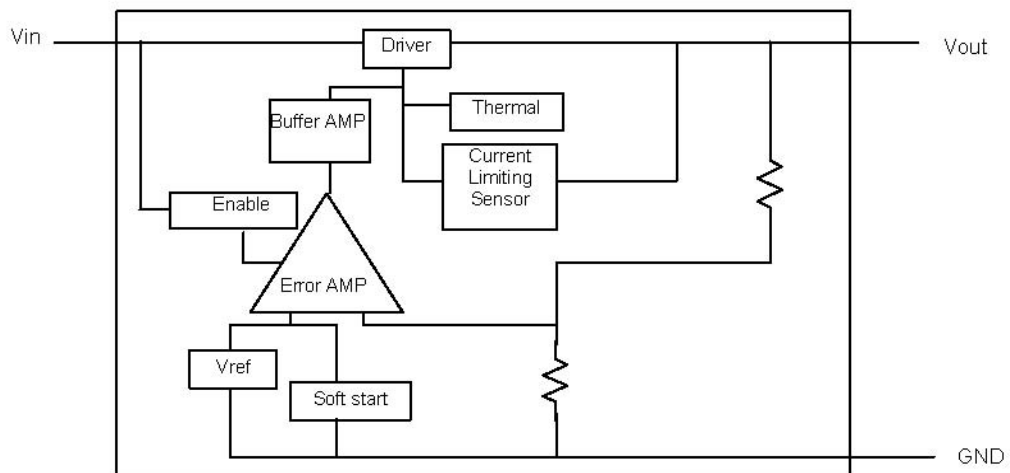
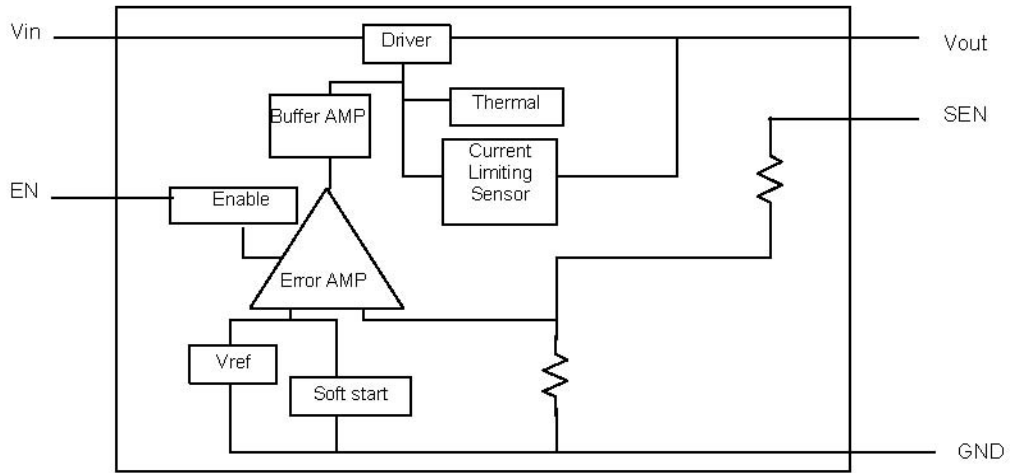

■ PIN DESCRIPTION

- VOUT PIN - Output voltage.
- GND PIN - Power GND.
- SEN PIN - Remote sense.
- VIN PIN - Power Input.
- EN PIN - Enable Input.

■ APPLICATION INFORMATION

Input/Output Capacitors

Linear regulators require input and output capacitors to maintain stability. A 4.7 μ F or 10 μ F electrolytic or tantalum capacitor is recommended for output. The output capacitor should be selected within the Equivalent Series Resistance (ESR).

Sense

Load is not usually close to regulator in actual application. The distance between these two devices results in decay of the load. A SENSE pin of the regulator connects to the load and traces the load voltage. AIC1187 will adjust the output voltage of the regulator to maintain the load at expected voltage.

■ PHYSICAL DIMENSIONS

● SOT-223

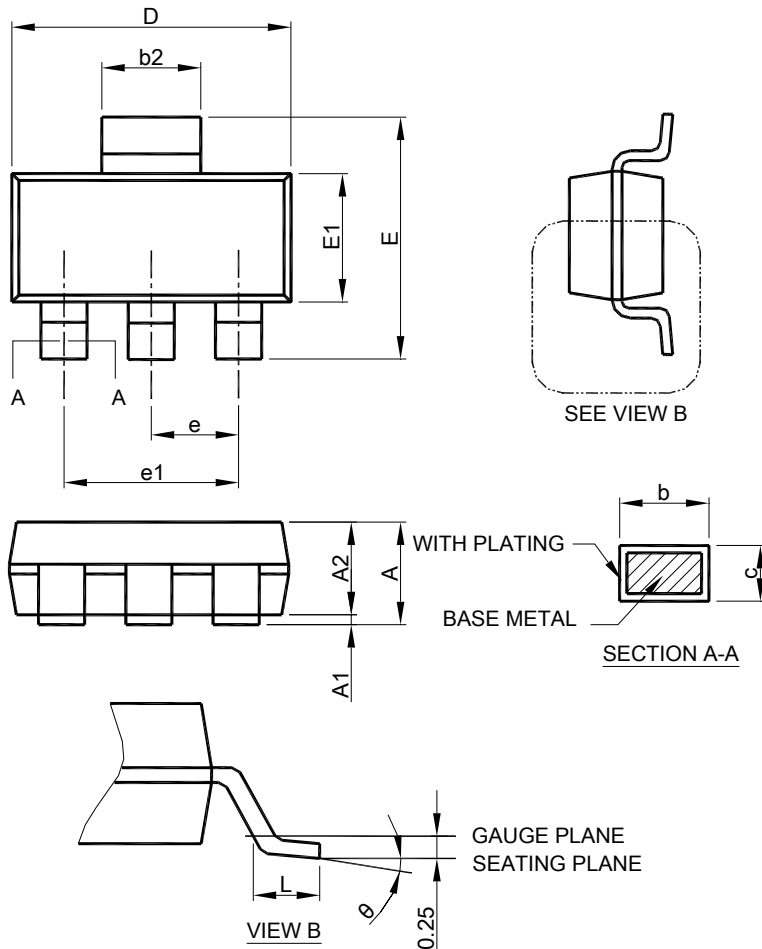

- Note: 1. Refer to JEDEC TO-261AA.
 2. Dimension "D" does not include mold flash, protrusions or gate burrs. Mold flash, protrusion or gate burrs shall not exceed 6 mil per side .
 3. Dimension "E1" does not include inter-lead flash or protrusions.
 4. Controlling dimension is millimeter, converted inch dimensions are not necessarily exact.

SYMBOL	SOT-223	
	MILLIMETERS	
	MIN.	MAX.
A		1.80
A1	0.02	0.10
A2	1.55	1.65
b	0.66	0.84
b2	2.90	3.10
c	0.23	0.33
D	6.30	6.70
E	6.70	7.30
E1	3.30	3.70
e	2.30 BSC	
e1	4.60 BSC	
L	0.90	
θ	0°	8°

● TO-220

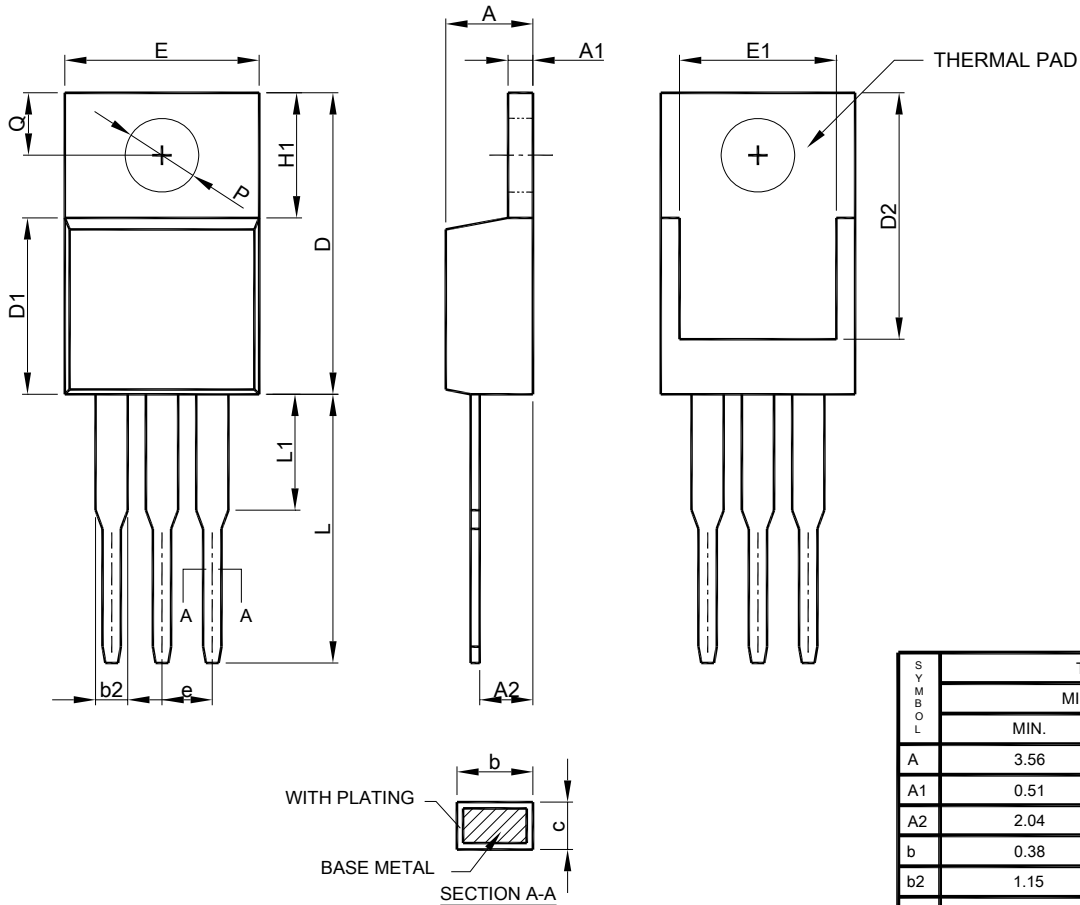

SYMBOL	TO-220	
	MILLIMETERS	
	MIN.	MAX.
A	3.56	4.82
A1	0.51	1.39
A2	2.04	2.92
b	0.38	1.01
b2	1.15	1.77
c	0.35	0.61
D	14.23	16.51
D1	8.38	9.02
D2	11.75	12.88
E	9.66	10.66
E1	6.86	8.90
e	2.54 BSC	
H1	5.85	6.85
L	12.70	14.73
L1	--	6.35
P	3.54	4.08
Q	2.54	3.42

- Note: 1. Refer to JEDEC TO-220AB.
 2. Dimension "E" does not include mold flash, protrusions or gate burrs. Mold flash, protrusion or gate burrs shall not exceed 6 mil per side .
 3. Dimension "D1" does not include inter-lead flash or protrusions.
 4. Controlling dimension is millimeter, converted inch dimensions are not necessarily exact.

● TO-263

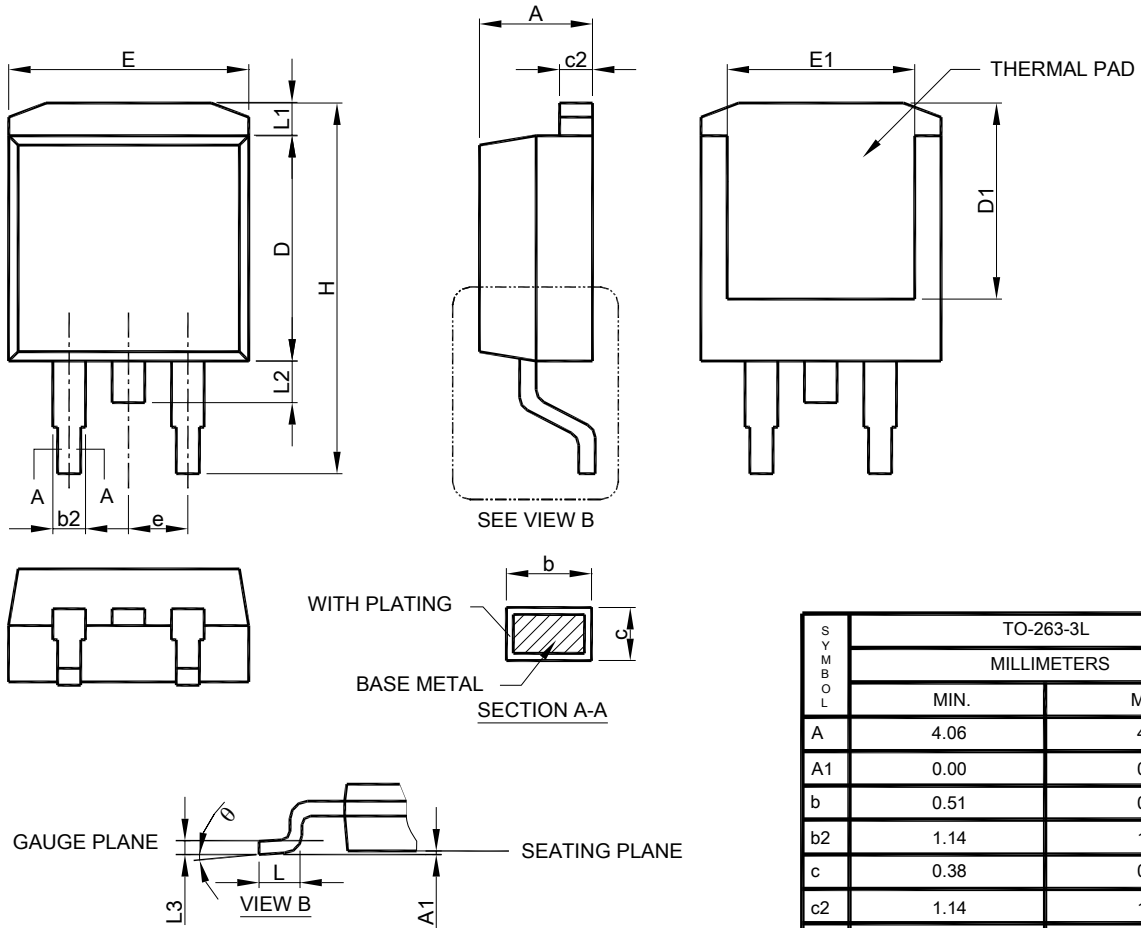

TO-263-3L		
MILLIMETERS		
SYMBOL	MIN.	MAX.
A	4.06	4.83
A1	0.00	0.25
b	0.51	0.99
b2	1.14	1.78
c	0.38	0.74
c2	1.14	1.65
D	8.38	9.65
D1	6.86	--
E	9.65	10.67
E1	6.23	--
e	2.54 BSC	
H	14.61	15.88
L	1.78	2.79
L1	--	1.68
L2	--	1.78
L3	0.25 BSC	
q	0°	8°

- Note: 1. Refer to JEDEC TO-263AB.
 2. Dimension "E" does not include mold flash, protrusions or gate burrs. Mold flash, protrusion or gate burrs shall not exceed 6 mil per side.
 3. Dimension "D" does not include inter-lead flash or protrusions.
 4. Controlling dimension is millimeter, converted inch dimensions are not necessarily exact.

● TO-263-5

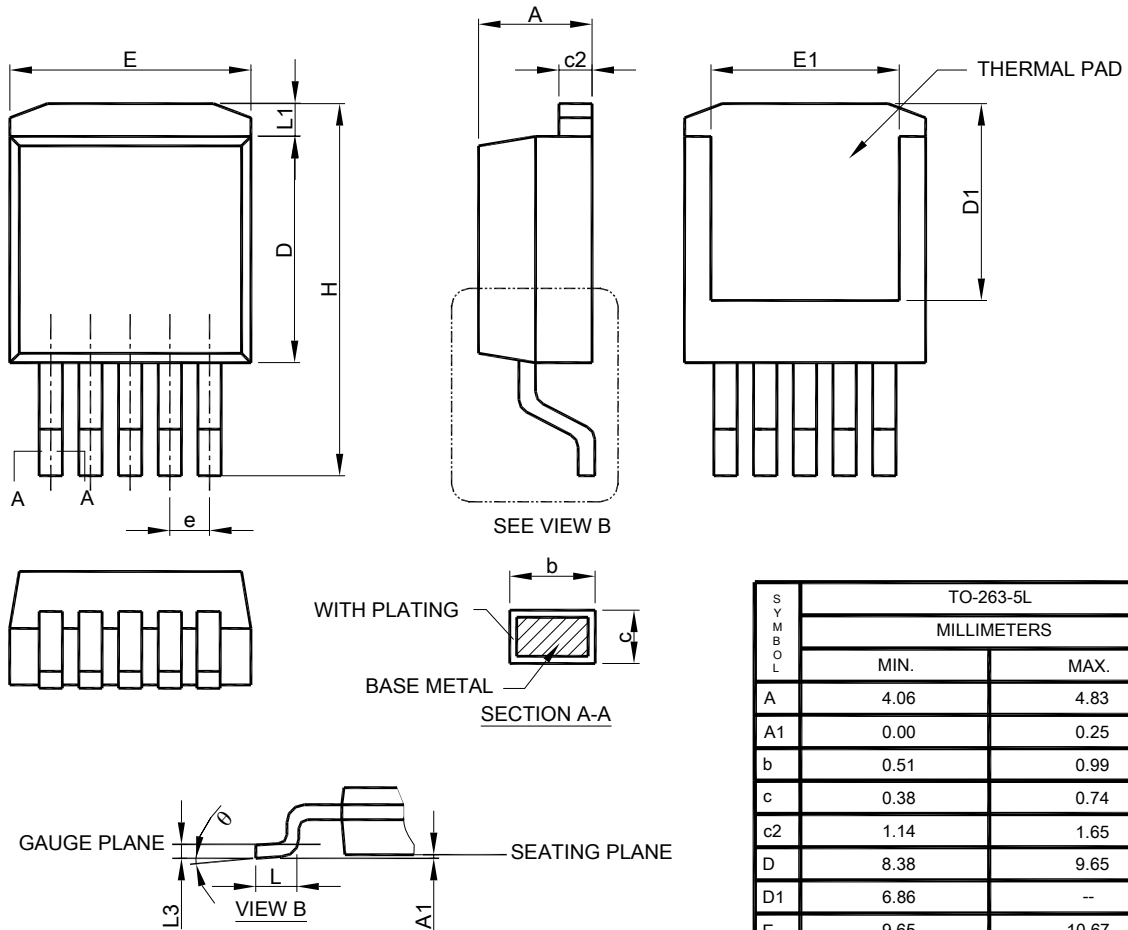

SYMBOL	TO-263-5L	
	MILLIMETERS	
	MIN.	MAX.
A	4.06	4.83
A1	0.00	0.25
b	0.51	0.99
c	0.38	0.74
c2	1.14	1.65
D	8.38	9.65
D1	6.86	--
E	9.65	10.67
E1	6.23	--
e	1.70 BSC	
H	14.61	15.88
L	1.78	2.79
L1	--	1.68
L3	0.25 BSC	
q	0°	8°

- Note: 1. Refer to JEDEC TO-263BA.
 2. Dimension "E" does not include mold flash, protrusions or gate burrs. Mold flash, protrusion or gate burrs shall not exceed 6 mil per side .
 3. Dimension "D" does not include inter-lead flash or protrusions.
 4. Controlling dimension is millimeter, converted inch dimensions are not necessarily exact.

● TO-252-5

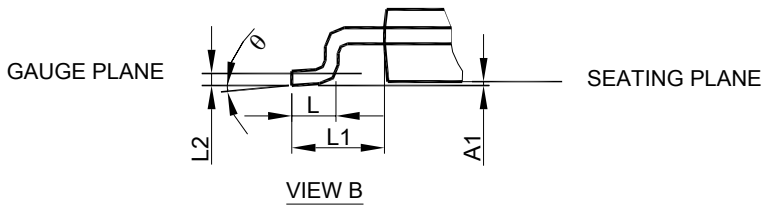
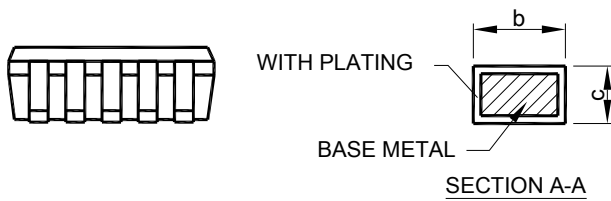
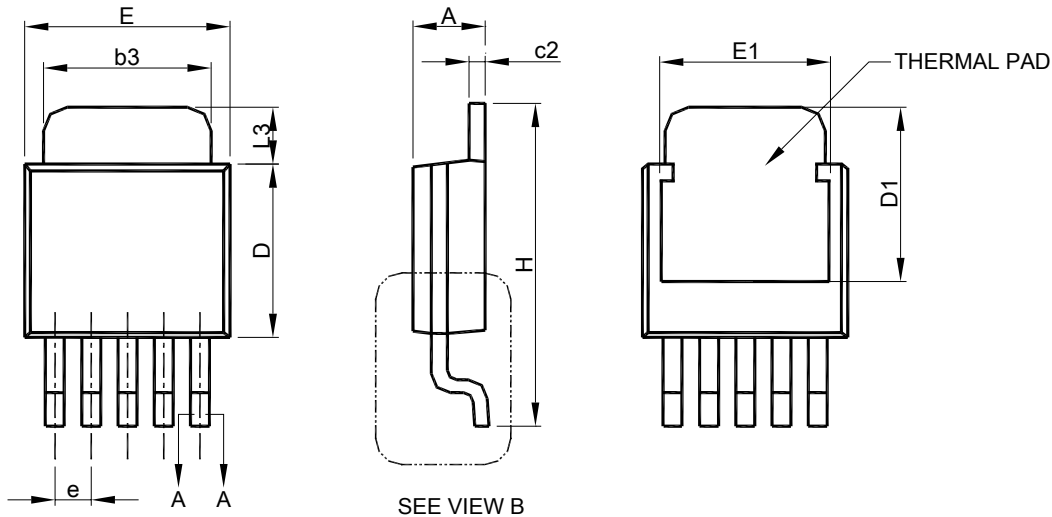

SYMBOL	TO-252-5L	
	MILLIMETERS	
	MIN.	MAX.
A	2.19	2.38
A1	0.00	0.13
b	0.51	0.71
b3	4.32	5.46
c	0.46	0.61
c2	0.46	0.89
D	5.33	6.22
D1	4.90	6.00
E	6.35	6.73
E1	4.32	5.33
e	1.27 BSC	
H	9.40	10.41
L	1.40	1.78
L1	2.67 REF	
L2	0.51 BSC	
L3	0.89	2.03
q	0°	8°

- Note: 1. Refer to JEDEC TO-252AD and AB.
 2. Dimension "E" does not include mold flash, protrusions or gate burrs. Mold flash, protrusion or gate burrs shall not exceed 6 mil per side .
 3. Dimension "D" does not include inter-lead flash or protrusions.
 4. Controlling dimension is millimeter, converted inch dimensions are not necessarily exact.

● TO-252

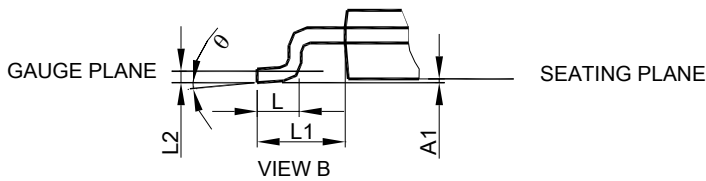
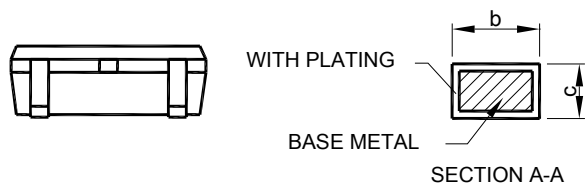
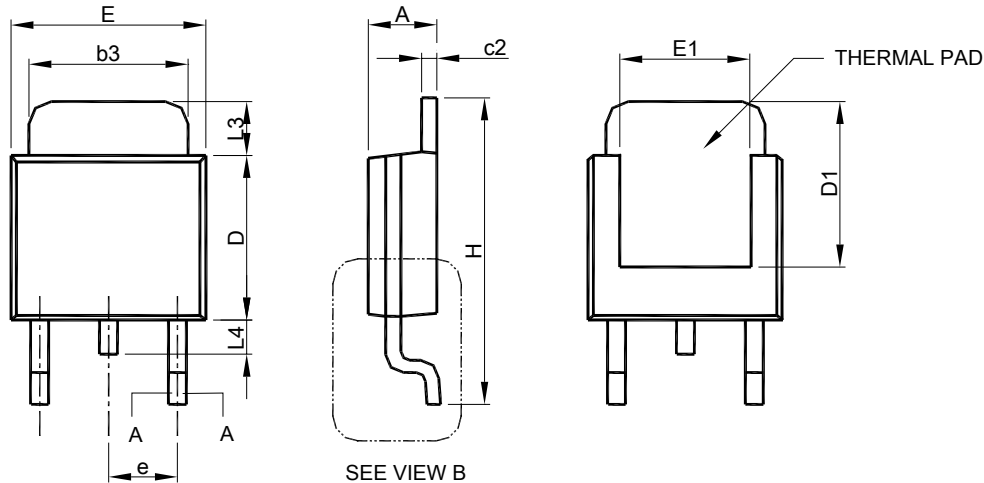

SYMBOL	TO-252-3L	
	MILLIMETERS	
	MIN.	MAX.
A	2.19	2.38
A1	0.00	0.13
b	0.64	0.89
b3	4.95	5.46
c	0.46	0.61
c2	0.46	0.89
D	5.33	6.22
D1	4.60	6.00
E	6.35	6.73
E1	3.90	5.46
e	2.28 BSC	
H	9.40	10.41
L	1.40	1.78
L1	2.67 REF	
L2	0.51 BSC	
L3	0.89	2.03
L4	--	1.02
θ	0°	8°

- Note: 1. Refer to JEDEC TO-252AA and AB.
 2. Dimension "E" does not include mold flash, protrusions or gate burrs. Mold flash, protrusion or gate burrs shall not exceed 6 mil per side .
 3. Dimension "D" does not include inter-lead flash or protrusions.
 4. Controlling dimension is millimeter, converted inch dimensions are not necessarily exact.

Note:

Information provided by AIC is believed to be accurate and reliable. However, we cannot assume responsibility for use of any circuitry other than circuitry entirely embodied in an AIC product; nor for any infringement of patents or other rights of third parties that may result from its use. We reserve the right to change the circuitry and specifications without notice.

Life Support Policy: AIC does not authorize any AIC product for use in life support devices and/or systems. Life support devices or systems are devices or systems which, (i) are intended for surgical implant into the body or (ii) support or sustain life, and whose failure to perform, when properly used in accordance with instructions for use provided in the labeling, can be reasonably expected to result in a significant injury to the user.