

Ultra LDO 1A Linear Regulator With Adjustable & Bypass Pin

■ FEATURES

- Guaranteed 1A Output Current.
- Fast Response in Line/Load Transient
- Wide Operating Voltage Ranges: 2.3V to 6.0V.
- 0.1 μ A Shutdown Standby Current
- Low Quiescent Current: < 60 μ A.
- Fixed: 1.2V, 1.5V, 1.8V, 2.0V, 2.5V, 2.7V, 3.0V, 3.3V, 3.5V, 3.7V, 3.8V Output Voltage.
- Adjustable Output Voltage are available from 0.8~4.5V
- Low Dropout : 440mV at 1A and 2.8V output voltage.
- High PSRR : 70dB at 1KHz.
- Active Low or High Shutdown Control. Current Limit and Thermal Protection.
- Available in \pm 2% Output Tolerance.
- Available in SOT-223 & TO-220 (3 pin) & SOP-8 Exposed Pad (Heat Sink) and TO-252 & TO-263 (3 & 5 pin) Package.

■ APPLICATIONS

- LCD TV, LCD Monitor, DPF
- Networking
- STB
- DVD, HDD Driver
- Portable AV Equipment
- PC Peripherals

■ TYPICAL APPLICATION CIRCUIT

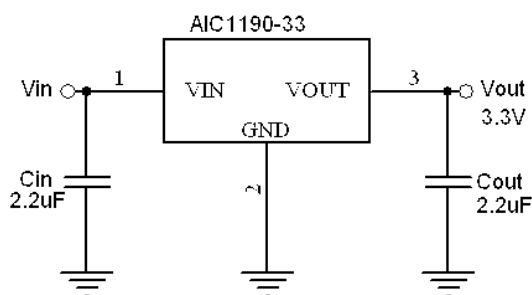

Fixed Linear Regulator

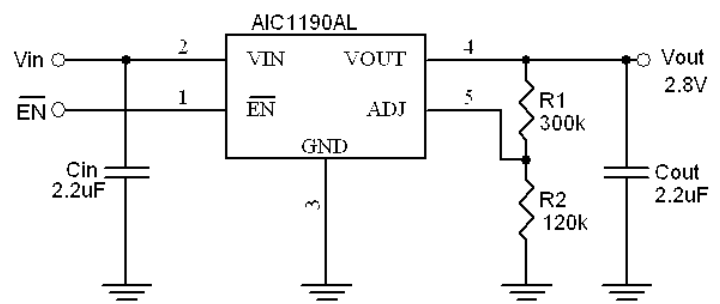

Adjustable Linear Regulator

■ DESCRIPTION

A low noise, high PSRR and ultra low dropout linear regulator AIC1190 is optimized for low ESR ceramic capacitors operation with 1A continuous current.

The AIC1190 offers high precision output voltage of \pm 2% tolerance. Output voltage can also be adjusted for those other than the preset values.

A noise bypass pin is available for further reduction of output noise. The bypass pin could be floating if it's unnecessary. At 1A load current and 2.8V output voltage, a 440mV dropout is performed. The quality of low quiescent current and low dropout voltage makes this device ideal for battery power applications. The high ripple rejection and low noise of the AIC1190 provide enhanced performances for critical applications such as cellular phones, and PDAs.

In addition, a logic-level shutdown input is included, which reduce supply current to less than 0.1 μ A (typ.) in shutdown mode with fast turn-on time less than 100 μ s. The AIC1190's current limit and thermal protection provide protection against any overload condition that would create excessive junction temperatures.

TYPICAL APPLICATION CIRCUIT (Continued)

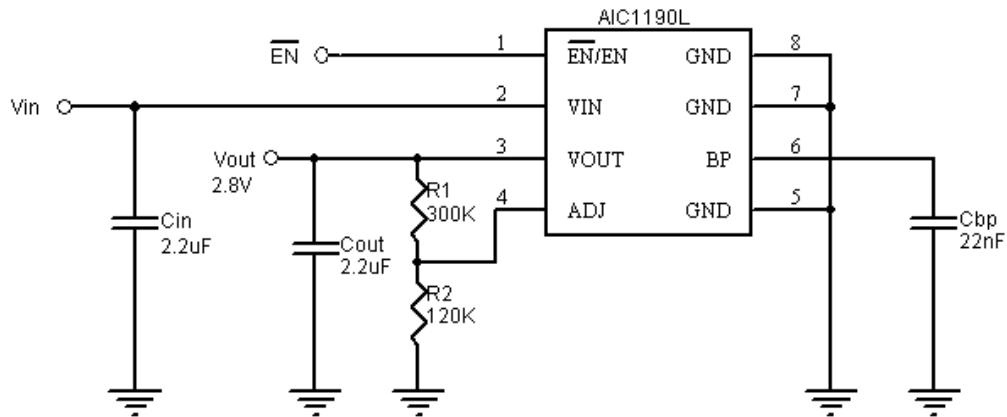

Adjustable Linear Regulator in SOP-8 Exposed Pad Package

ORDERING INFORMATION

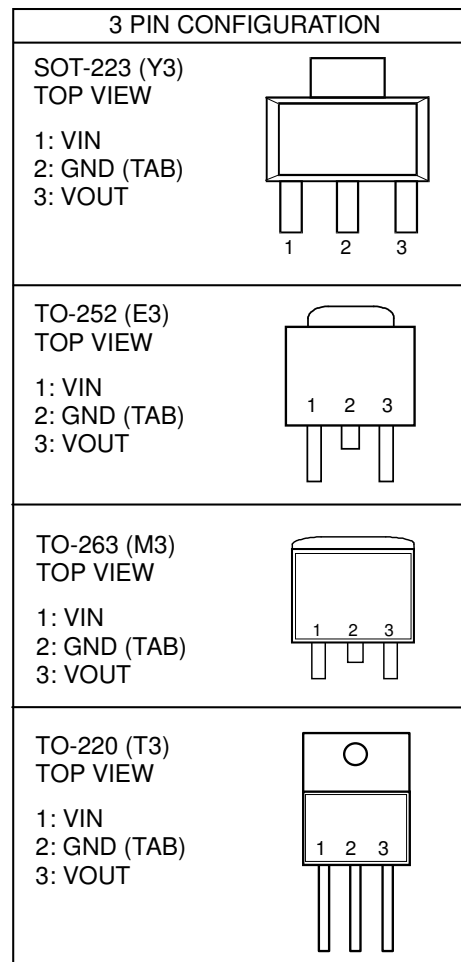
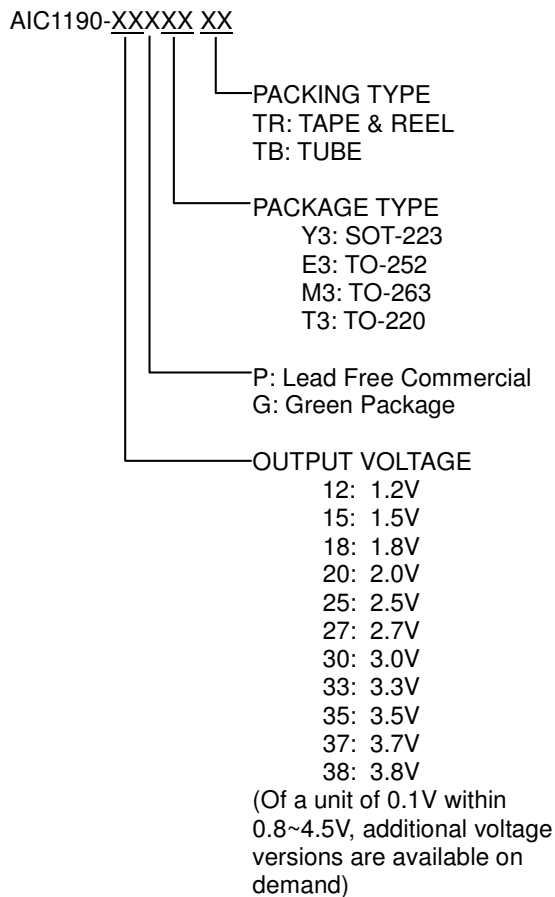

Example: AIC1190-18PE3TR

→ 1.8V Version, in TO-252 Lead Free
Package & Tape & Reel Packing Type

■ ORDERING INFORMATION (Continued)

AIC1190XX-XXXXXXXX

PACKING TYPE
 TR: TAPE & REEL
 TB: TUBE

PACKAGE TYPE
 E5: TO-252-5
 M5: TO-263-5

P: Lead Free Commercial
 G: Green Package

OUTPUT VOLTAGE
 12: 1.2V
 15: 1.5V
 18: 1.8V
 20: 2.0V
 25: 2.5V
 27: 2.7V
 30: 3.0V
 33: 3.3V
 35: 3.5V
 37: 3.7V
 38: 3.8V

(Of a unit of 0.1V within
 0.8~4.5V, additional voltage
 versions are available on
 demand)

ENABLE TYPE
 L: Chip Enable Low
 H: Chip Enable High

B: Bypass
 A: ADJ

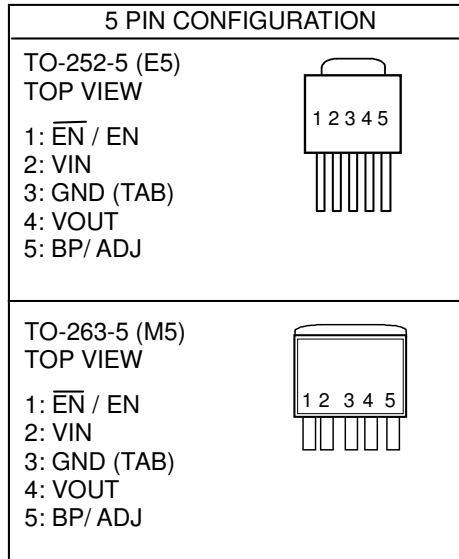

Example: AIC1190BH-18PM5TR
 → With Bypass Pin, Chip Enable High,
 1.8V Version, in TO-263-5 Lead Free
 Package & Tape & Reel Packing Type

ORDERING INFORMATION (Continued)

AIC1190X-XXXXXXXX

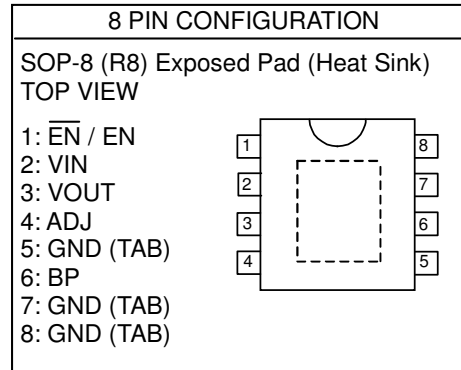
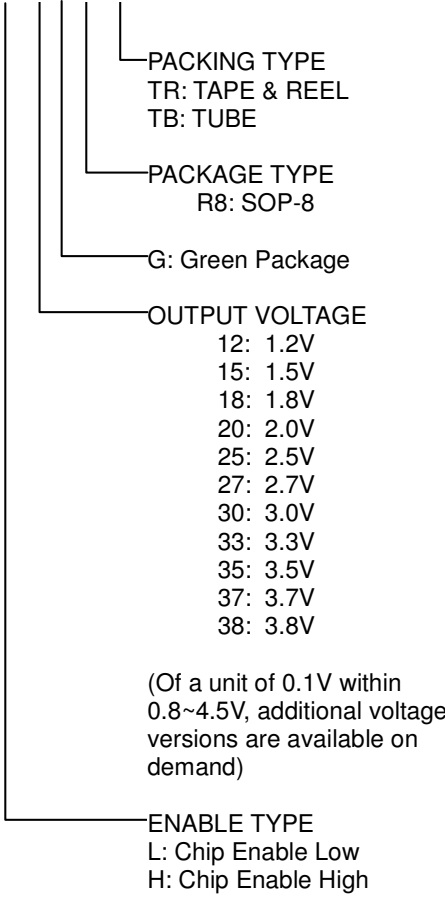

Example: AIC1190H-18GR8TR

→ Chip Enable High, 1.8V Version, in SOP-8 Green Package & Tape & Reel Packing Type

● **Marking**

Part No	Marking	Part No	Marking
AIC1190-xxPY3	HBxxP	AIC1190-xxGY3	HBxxG

xx represents output voltage. (08=0.8V, 09=0.9V,, 44=4.4V, 45=4.5V)

■ **ABSOLUTE MAXIMUM RATINGS**

Input Voltage	7V
EN Pin Voltage	7V
Noise Bypass Terminal Voltage	7V
Operating Temperature Range	-40°C~85°C
Maximum Junction Temperature	150°C
Storage Temperature Range	-65°C~150°C
Lead Temperature (Soldering, 10 sec)	260°C
Thermal Resistance (Junction to Case)	
SOT-223	15°C /W
TO-252.....	8°C /W
TO-263.....	3°C /W
TO-220.....	3°C /W
SOP-8 (Exposed Pad*).....	15°C /W
Thermal Resistance (Junction to Ambient)	
SOT-223	130°C /W
(Assume no ambient airflow, no heat sink)	
TO-252.....	100°C /W
TO-263.....	60°C /W
TO-220.....	50°C /W
(Assume no ambient airflow)	
SOP-8 (Exposed Pad*)	60°C /W

Absolute Maximum Ratings are those values beyond which the life of a device may be impaired.

* The package is placed on a two layers PCB with 2 ounces copper and 2 square inch, connected by 8 vias.

ELECTRICAL CHARACTERISTICS
($C_{IN} = C_{OUT} = 2.2\mu F$, $C_{BP} = 22nF$, $V_{IN} = V_{OUT} + 1V$, $T_J = 25^\circ C$, unless otherwise specified) (Note 1)

PARAMETER	TEST CONDITIONS	SYMBOL	MIN.	TYP.	MAX.	UNIT
Input Voltage		V_{IN}	2.3		6.0	V
Output Voltage Tolerance	$I_{OUT} = 1\text{ mA}$	V_{OUT}	-2		2	%
Continuous Output Current		I_{OUT}	1.0			A
Quiescent Current	Chip Enable Low, $V_{EN} \leq 0.4V$, $I_{OUT} = 0\text{ mA}$ Chip Enable High, $V_{EN} \geq 1.6V$, $I_{OUT} = 0\text{ mA}$	I_Q		60	110	μA
GND Pin Current	Chip Enable Low, $V_{EN} \leq 0.4V$, $I_{OUT} = 1A$ Chip Enable High, $V_{EN} \geq 1.6V$, $I_{OUT} = 1A$	I_{GND}		60	110	μA
Standby Current	Chip Enable Low, $V_{EN} = V_{IN}$ Chip Enable High, $V_{EN} = 0$	I_{STBY}		0.1	0.5	μA
Output Current Limit	$R_{LOAD} = 0.1\Omega$	I_{IL}	1.1	1.6		A
Dropout Voltage	$I_{OUT} = 1A$, $0.8V < V_{OUT} < 2V$	V_{DROP}			1500	mV
	$I_{OUT} = 1A$, $2V < V_{OUT} < 2.8V$				500 900	
	$I_{OUT} = 1A$, $V_{OUT} > 2.8V$				440 700	
Line Regulation	$V_{IN} = V_{OUT} + 1V$ to 6.0V	ΔV_{LIR}			10	mV
Load Regulation	$I_{OUT} = 1mA$ to 1A	ΔV_{LOR}			1 20	mV
Ripple Rejection (Note 2)	$f = 1KHz$, Ripple = 0.5Vp-p,	PSRR			70	dB
Output Noise Voltage	$C_{BP} = 22nF$, $f = 10 \sim 100KHz$				24	μV_{rms}
Temperature Coefficient		TC			50	ppm/ $^\circ C$
Thermal Shutdown Temperature	$V_{IN} = V_{OUT} + 1V$	T_{SD}			150	$^\circ C$
Thermal Shutdown Hysteresis		ΔT_{SD}			20	$^\circ C$
ADJ Pin Specifications						
ADJ Pin Current	$V_{ADJ} = V_{REF}$	I_{ADJ}			10 100	nA
ADJ Pin Threshold		$V_{TH(ADJ)}$	0.05	0.1	0.2	V
Reference Voltage Tolerance		V_{REF}	0.784	0.8	0.816	V

ELECTRICAL CHARACTERISTICS (Continued)

PARAMETER	TEST CONDITIONS	SYMBOL	MIN.	TYP.	MAX.	UNIT
Shutdown Pin Specifications						
Shutdown Pin Current	$V_{EN} = V_{IN}$ or GND	I_{EN}		0	100	nA
Shutdown Exit Delay Time	$I_{OUT} = 30\text{mA}$	Δt		100		μS
Max Output Discharge Resistance to GND during Shutdown		R_{DSON_CLMP}		20	100	Ω
Shutdown Input Threshold	Chip Enable Low, Output OFF, $V_{IN} = 2.3\text{V}$ to 6.0V	V_{ENH}	1.6			V
	Chip Enable High, Output ON, $V_{IN} = 2.3\text{V}$ to 6.0V	V_{ENL}			0.4	

Note 1: Specifications are production tested at $T_A = 25^\circ\text{C}$. Specifications over the -40°C to 85°C operating temperature range are assured by design, characterization and correlation with Statistical Quality Controls (SQC).

Note 2: Connecting a 22nF bypass capacitor to BP pin can improve AIC1190 PSRR in High frequency.

■ TYPICAL PERFORMANCE CHARACTERISTICS

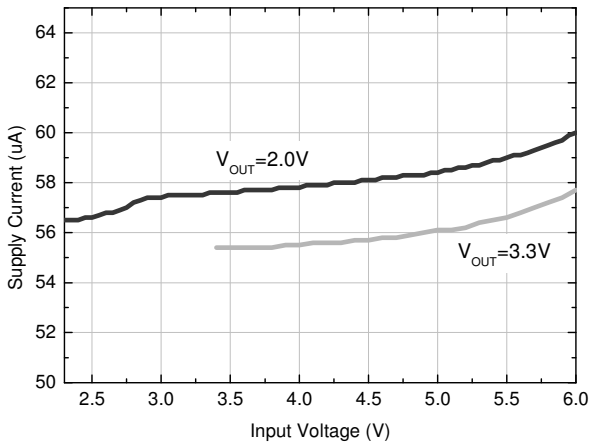

Fig. 1 Supply Current vs. Input Voltage

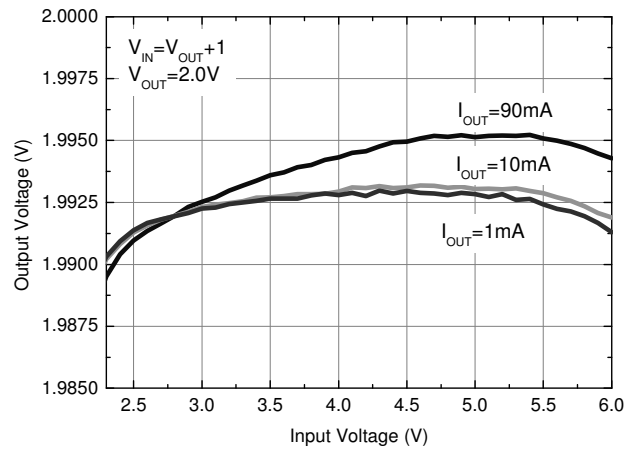

Fig. 2 Output Voltage vs. Input Voltage

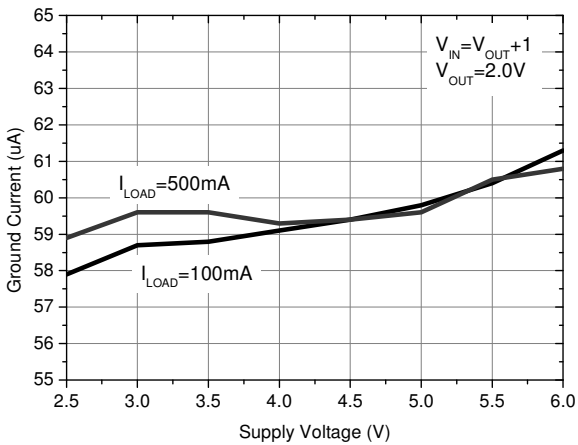

Fig. 3 Ground Current

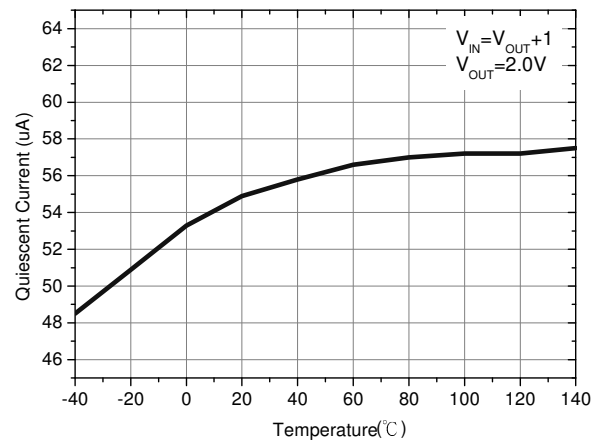

Fig. 4 Quiescent Current vs. Temperature

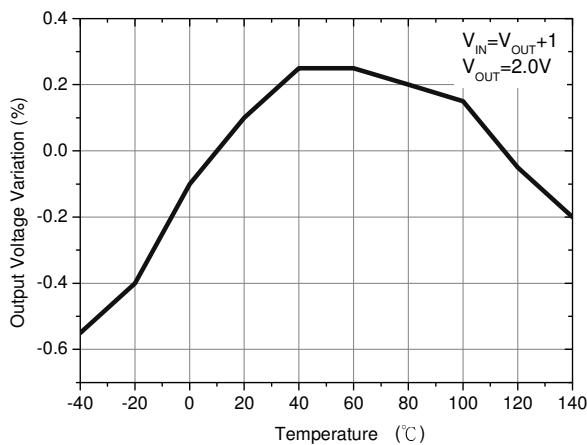

Fig. 5 Output Voltage vs. Temperature

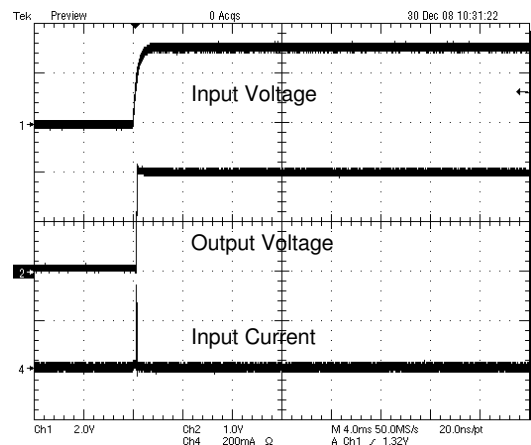

Fig. 6 Start-up waveform without bypass capacitance

■ TYPICAL PERFORMANCE CHARACTERISTICS (Continued)

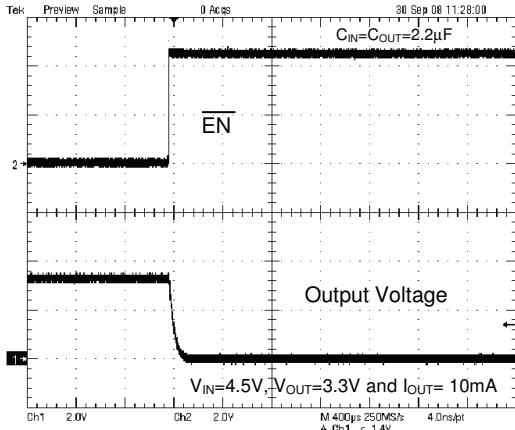

Fig.7 Shutdown Transient

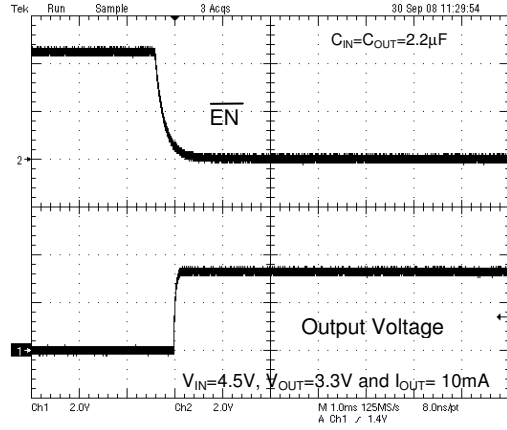

Fig. 8 Start-up waveform without bypass capacitor

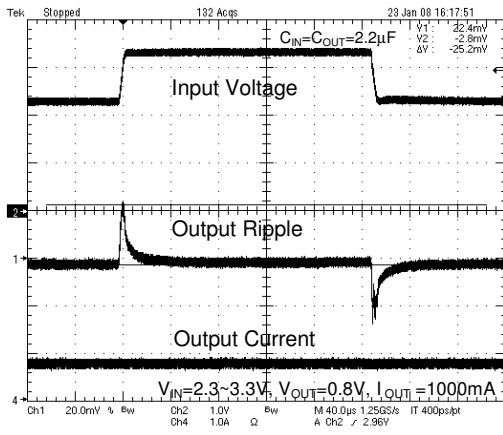

Fig. 9 Line Transient

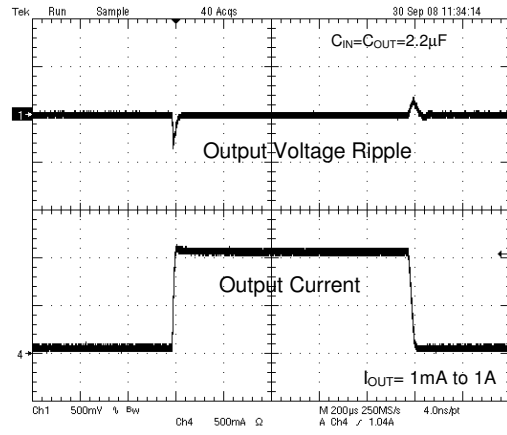

Fig.10 Load Transient Response at VIN=4.3V, VOUT=3.3V

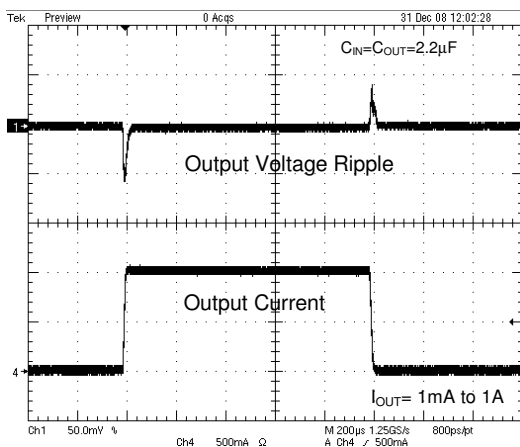

Fig.11 Load Transient Response at VIN=2.3V, VOUT=0.8V

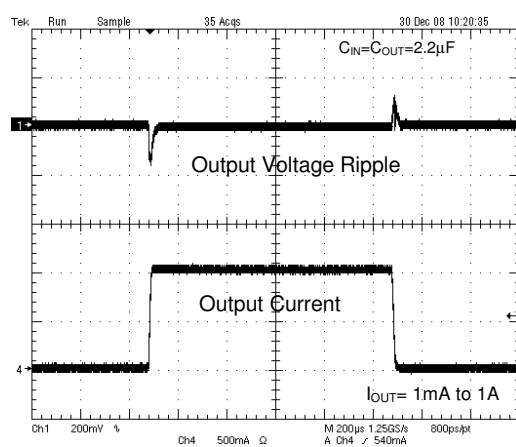

Fig.12 Load Transient Response at VIN=3.0V, VOUT=2.0V

■ TYPICAL PERFORMANCE CHARACTERISTICS (Continued)

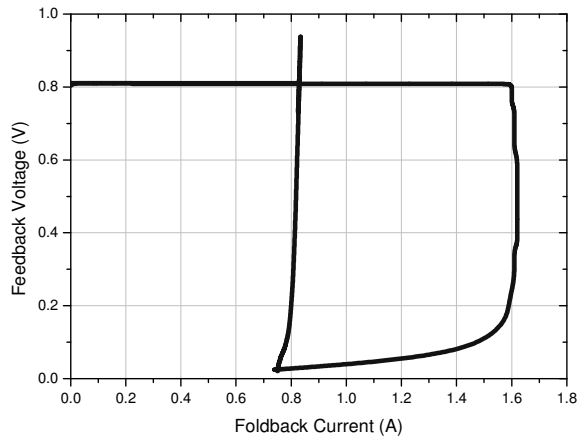

Fig. 13 Current Fold back ($V_{out} < 0.2V$)

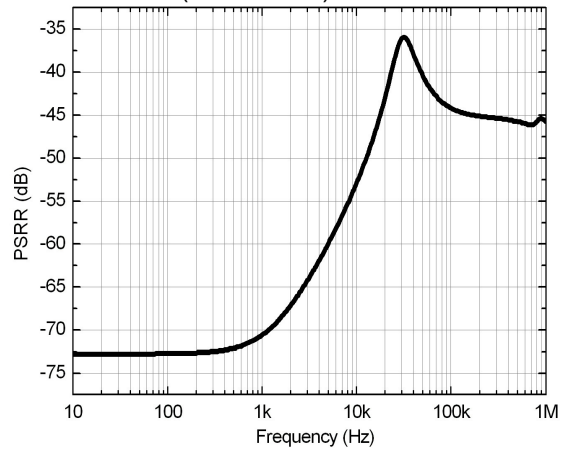
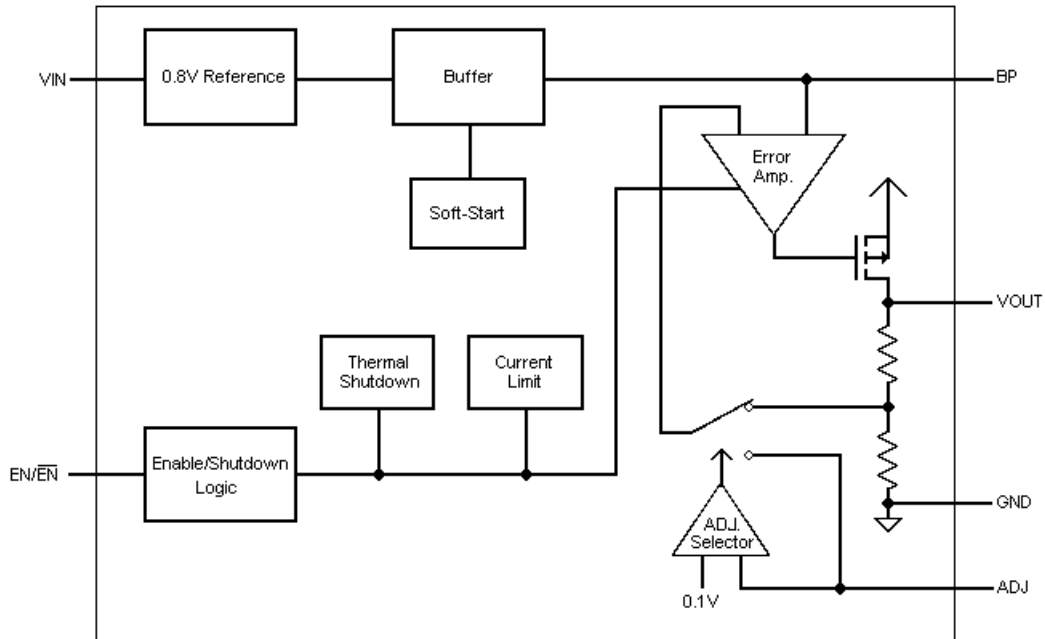

Fig. 14 PSRR Curve

■ BLOCK DIAGRAM

■ PIN DESCRIPTION

- VIN – Power supply input pin. Bypass with a 2.2 μ F capacitor to GND
- GND – Ground.
- VOUT – Regulator Output pin. Sources up to 1A.
- $\overline{\text{EN}}$ (5 Pin and 8 Pin) – Chip Enable (Active Low). This pin isn't allowed to float.
- EN (5 Pin and 8 Pin) – Chip Enable (Active High). This pin isn't allowed to float.
- BP (5 Pin and 8 Pin) – Bypass pin. It can connect to external 22nF capacitor to GND to reduce output noise. The bypass pin could be floating if it's unnecessary (Keep floating cannot pull low and pull high).
- ADJ (5 Pin and 8 Pin) – The output voltage can either be set by the internal feedback resistors when this pin is grounded, or be set by the external feedback resistors when using a resistive divider.

■ APPLICATION INFORMATION

The AIC1190 is a high performance linear regulator that provides low-dropout voltage and low quiescent-current. The device is available in an adjustable version and fixed output voltages ranging from 1.2V to 3.8V, and the device can supply loads up to 1A.

SHUTDOWN

By connecting $\overline{\text{EN}}$ (EN) pin to V_{IN} (ground), the AIC1190 can be shut down to reduce the supply current to 0.1 μ A(typ.). At this operation mode, the output voltage of AIC1190 is equal to 0V.

CURRENT LIMIT

The AIC1190 includes a current limiter, which monitors and controls the maximum output current. If the output is overloaded or shorted to ground, this can protect the device from being damaged.

THERMAL PROTECTION

The AIC1190 includes a thermal-limiting circuit, which is designed to protect the device against overload condition. When the junction temperature exceeds $T_{\text{J}}=150^{\circ}\text{C}$, the thermal-limiting circuit turns off the pass transistor and allows the IC to cool. For continuous load condition, maximum rating of junction temperature must not be exceeded.

INPUT-OUTPUT CAPACITORS

Linear regulators require input and output capacitors to maintain stability. Input capacitor at 2.2 μ F with a 2.2 μ F ceramic output capacitor is recommended. To avoid oscillation, it is recommended to follow the figure of "Region of Stable C_{OUT} ESR vs. Load Current" to choose proper capacitor specifications.

When choosing the input and output ceramic capacitors, X5R and X7R types are recommended because they retain their capacitance over wider ranges of voltage and temperature than other types.

NOISE BYPASS CAPACITOR

A 22nF bypass capacitor at BP pin can reduce output

voltage noise. The bypass pin can be floating if it's unnecessary.

OUTPUT VOLTAGE PROGRAMMING

The output voltage of AIC1190 linear regulator can be set by its internal feedback resistors when the ADJ pin is grounded. In addition, the output voltage of AIC1190 linear regulator can be set by the external feedback resistors when connecting a resistive divider R_1 and R_2 . While connecting a resistive divider, V_{OUT} can be calculated as:

$$V_{\text{OUT}} = 0.8 \times \left(1 + \frac{R_1}{R_2} \right)$$

The resistive divider should sit as close to ADJ pin as possible.

POWER DISSIPATION

The maximum power dissipation of AIC1190 depends on the thermal resistance of its case and circuit board, the temperature difference between the die junction and ambient air, and the rate of airflow. The rate of temperature rise is greatly affected by the mounting pad configuration on the PCB, the board material, and the ambient temperature. When the IC mounting with good thermal conductivity is used, the junction temperature will be low even when large power dissipation applies.

The power dissipation across the device is

$$P = I_{\text{OUT}} (V_{\text{IN}} - V_{\text{OUT}})$$

The maximum power dissipation is:

$$P_{\text{MAX}} = \frac{(T_{\text{J-max}} - T_{\text{A}})}{R\theta_{\text{JA}}}$$

Where $T_{\text{J-max}}$ is the maximum allowable junction temperature (150 $^{\circ}\text{C}$), and T_{A} is the ambient temperature suitable in application.

As a general rule, the lower temperature is, the better reliability of the device is. So the PCB mounting pad should provide maximum thermal conductivity to maintain low device temperature.

■ PHYSICAL DIMENSIONS

● SOT-223 PACKAGE OUTLINE DRAWING

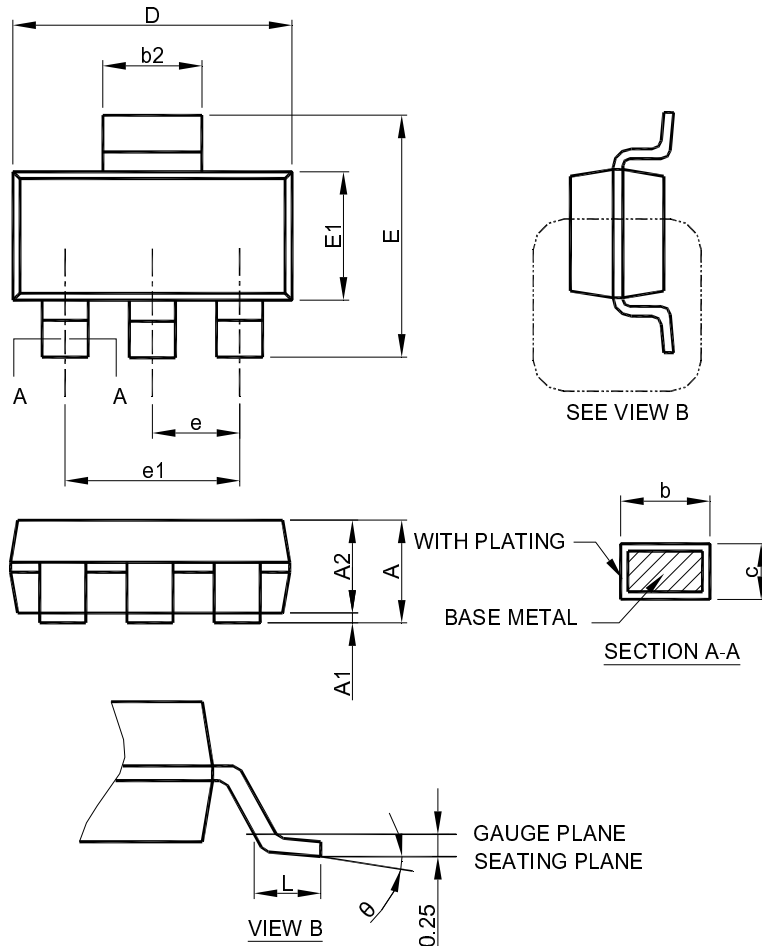

Note: 1. Refer to JEDEC TO-261AA.

2. Dimension "D" does not include mold flash, protrusions or gate burrs. Mold flash, protrusion or gate burrs shall not exceed 6 mil per side .
3. Dimension "E1" does not include inter-lead flash or protrusions.
4. Controlling dimension is millimeter, converted inch dimensions are not necessarily exact.

SYMBOL	SOT-223	
	MILLIMETERS	
	MIN.	MAX.
A		1.80
A1	0.02	0.10
A2	1.55	1.65
b	0.66	0.84
b2	2.90	3.10
c	0.23	0.33
D	6.30	6.70
E	6.70	7.30
E1	3.30	3.70
e	2.30 BSC	
e1	4.60 BSC	
L	0.90	
theta	0°	8°

● TO-252-3L PACKAGE OUTLINE DRAWING

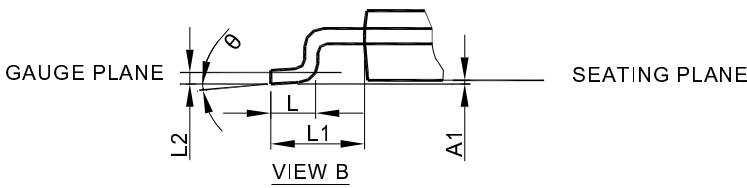
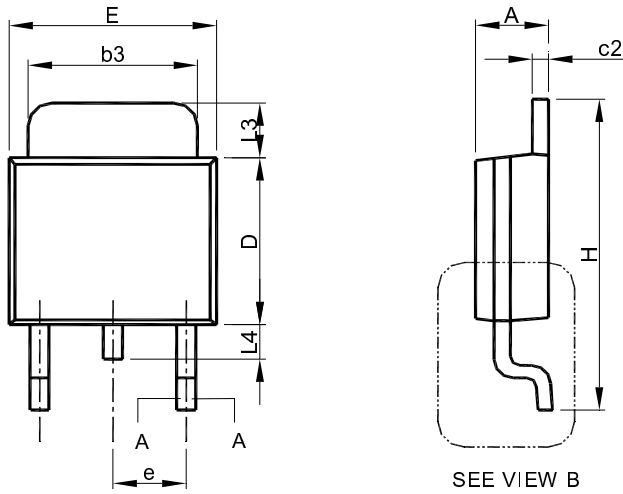

- Note: 1. Refer to JEDEC TO-252AA and AB.
 2. Dimension "E" does not include mold flash, protrusions or gate burrs. Mold flash, protrusion or gate burrs shall not exceed 6 mil per side .
 3. Dimension "D" does not include inter-lead flash or protrusions.
 4. Controlling dimension is millimeter, converted inch dimensions are not necessarily exact.

SYMBOL	TO-252-3L	
	MILLIMETERS	
	MIN.	MAX.
A	2.19	2.38
A1	0.00	0.13
b	0.64	0.89
b3	4.95	5.46
c	0.46	0.61
c2	0.46	0.89
D	5.33	6.22
E	6.35	6.73
e	2.28 BSC	
H	9.40	10.41
L	1.40	1.78
L1	2.67 REF	
L2	0.51 BSC	
L3	0.89	2.03
L4	--	1.02
θ	0°	8°

● TO-252-5L PACKAGE OUTLINE DRAWING

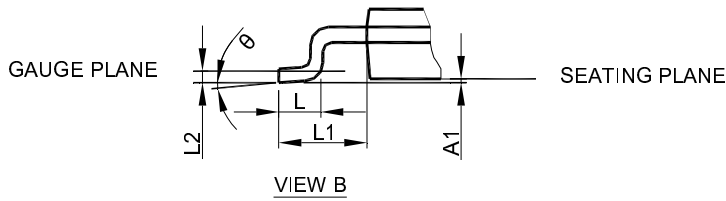
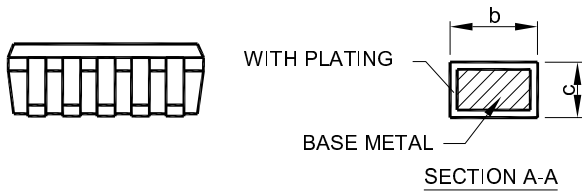
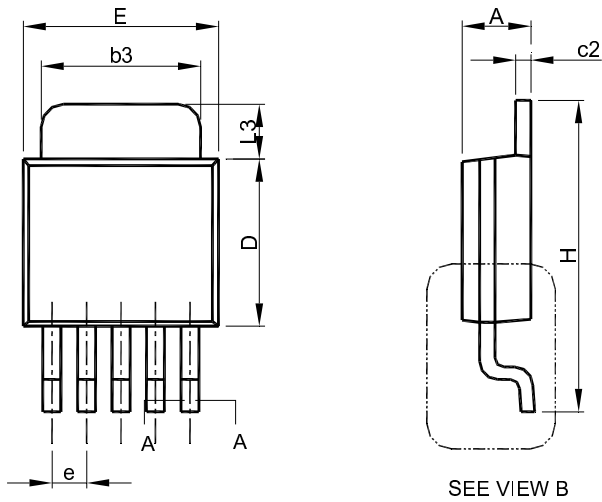

- Note: 1. Refer to JEDEC TO-252AD and AB.
 2. Dimension "E" does not include mold flash, protrusions or gate burrs. Mold flash, protrusion or gate burrs shall not exceed 6 mil per side .
 3. Dimension "D" does not include inter-lead flash or protrusions.
 4. Controlling dimension is millimeter, converted inch dimensions are not necessarily exact.

SYMBOL	TO-252-5L	
	MILLIMETERS	
	MIN.	MAX.
A	2.19	2.38
A1	0.00	0.13
b	0.51	0.71
b3	4.32	5.46
c	0.46	0.61
c2	0.46	0.89
D	5.33	6.22
E	6.35	6.73
e	1.27 BSC	
H	9.40	10.41
L	1.40	1.78
L1	2.67 REF	
L2	0.51 BSC	
L3	0.89	2.03
q	0°	8°

● TO-263-3L PIN PACKAGE OUTLINE DRAWING

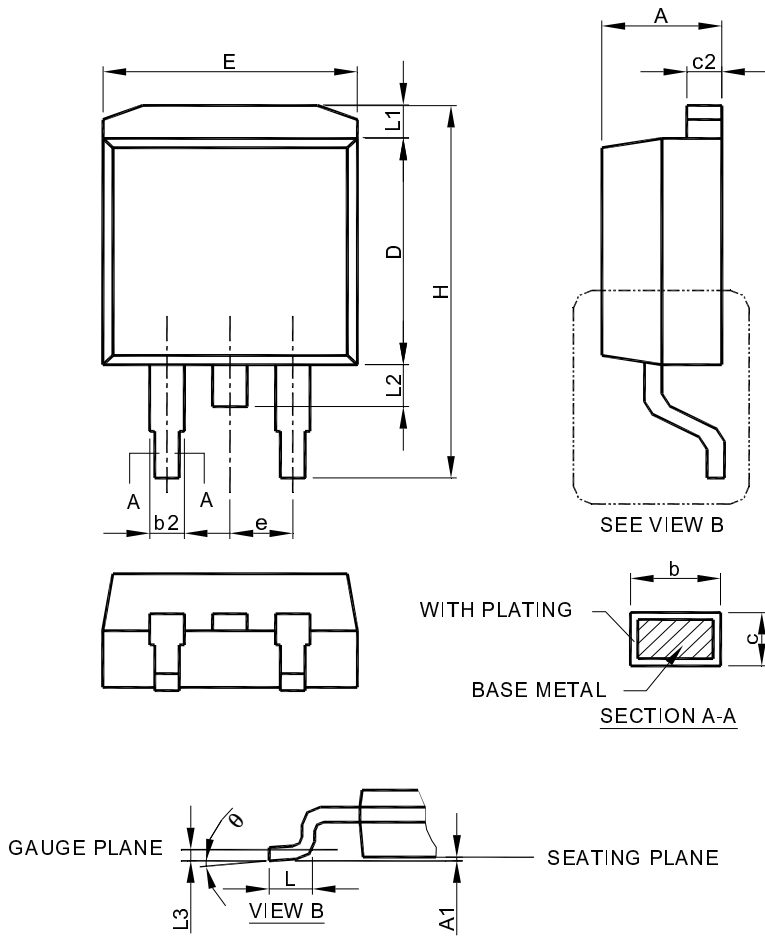

- Note: 1. Refer to JEDEC TO-263AB.
 2. Dimension "E" does not include mold flash, protrusions or gate burrs. Mold flash, protrusion or gate burrs shall not exceed 6 mil per side.
 3. Dimension "D" does not include inter-lead flash or protrusions.
 4. Controlling dimension is millimeter, converted inch dimensions are not necessarily exact.

SYMBOL	TO-263-3L	
	MILLIMETERS	
	MIN.	MAX.
A	4.06	4.83
A1	0.00	0.25
b	0.51	0.99
b2	1.14	1.78
c	0.38	0.74
c2	1.14	1.65
D	8.38	9.65
E	9.65	10.67
e	2.54 BSC	
H	14.61	15.88
L	1.78	2.79
L1	--	1.68
L2	--	1.78
L3	0.25 BSC	
q	0°	8°

● TO-263-5L PACKAGE OUTLINE DRAWING

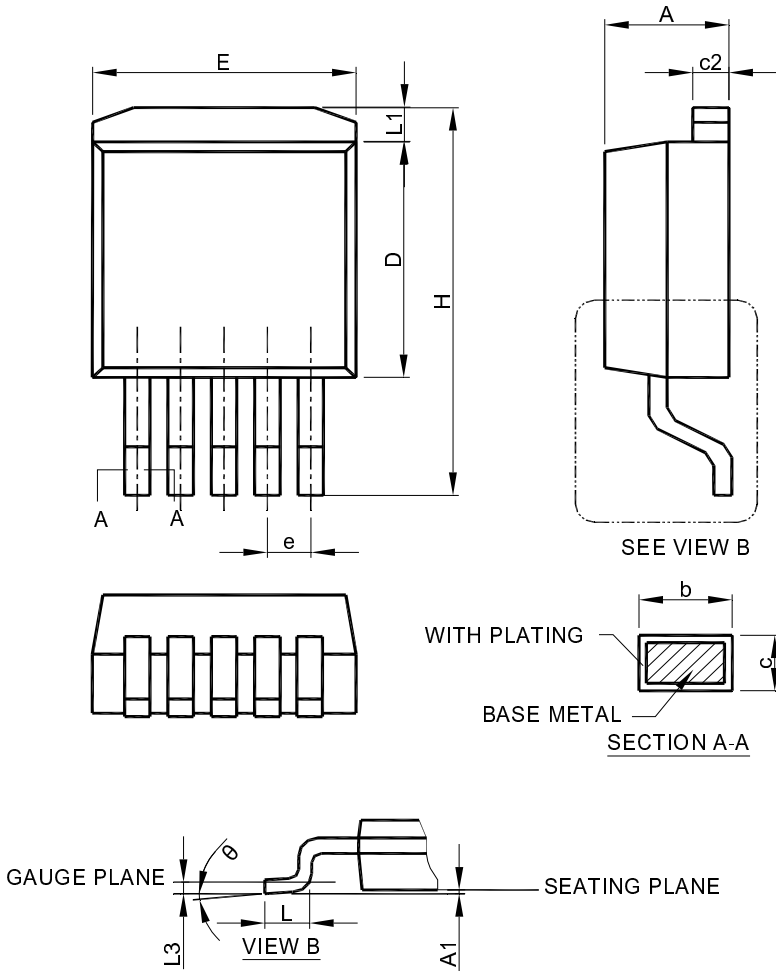

SYMBOL	TO-263-5L	
	MILLIMETERS	
	MIN.	MAX.
A	4.06	4.83
A1	0.00	0.25
b	0.51	0.99
c	0.38	0.74
c2	1.14	1.65
D	8.38	9.65
E	9.65	10.67
e	1.70 BSC	
H	14.61	15.88
L	1.78	2.79
L1	--	1.68
L3	0.25 BSC	
q	0°	8°

- Note: 1. Refer to JEDEC TO-263BA.
 2. Dimension "E" does not include mold flash, protrusions or gate burrs. Mold flash, protrusion or gate burrs shall not exceed 6 mil per side.
 3. Dimension "D" does not include inter-lead flash or protrusions.
 4. Controlling dimension is millimeter, converted inch dimensions are not necessarily exact.

● TO-220 PACKAGE OUTLINE DRAWING

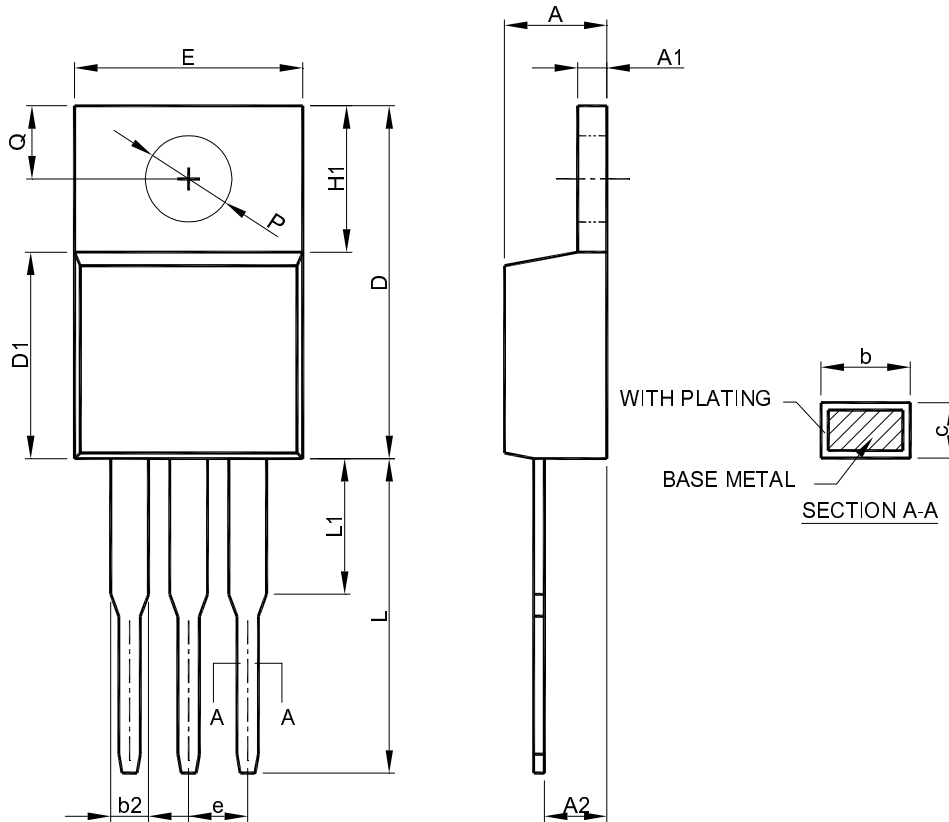

- Note: 1. Refer to JEDEC TO-220AB.
 2. Dimension "E" does not include mold flash, protrusions or gate burrs. Mold flash, protrusion or gate burrs shall not exceed 6 mil per side .
 3. Dimension "D1" does not include inter-lead flash or protrusions.
 4. Controlling dimension is millimeter, converted inch dimensions are not necessarily exact.

SYMBOL	TO-220	
	MILLIMETERS	
	MIN.	MAX.
A	3.56	4.82
A1	0.51	1.39
A2	2.04	2.92
b	0.38	1.01
b2	1.15	1.77
c	0.35	0.61
D	14.23	16.51
D1	8.38	9.02
E	9.66	10.66
e	2.54 BSC	
H1	5.85	6.85
L	12.70	14.73
L1	--	6.35
P	3.54	4.08
Q	2.54	3.42

● SOP-8 Exposed Pad PACKAGE OUTLINE DRAWING

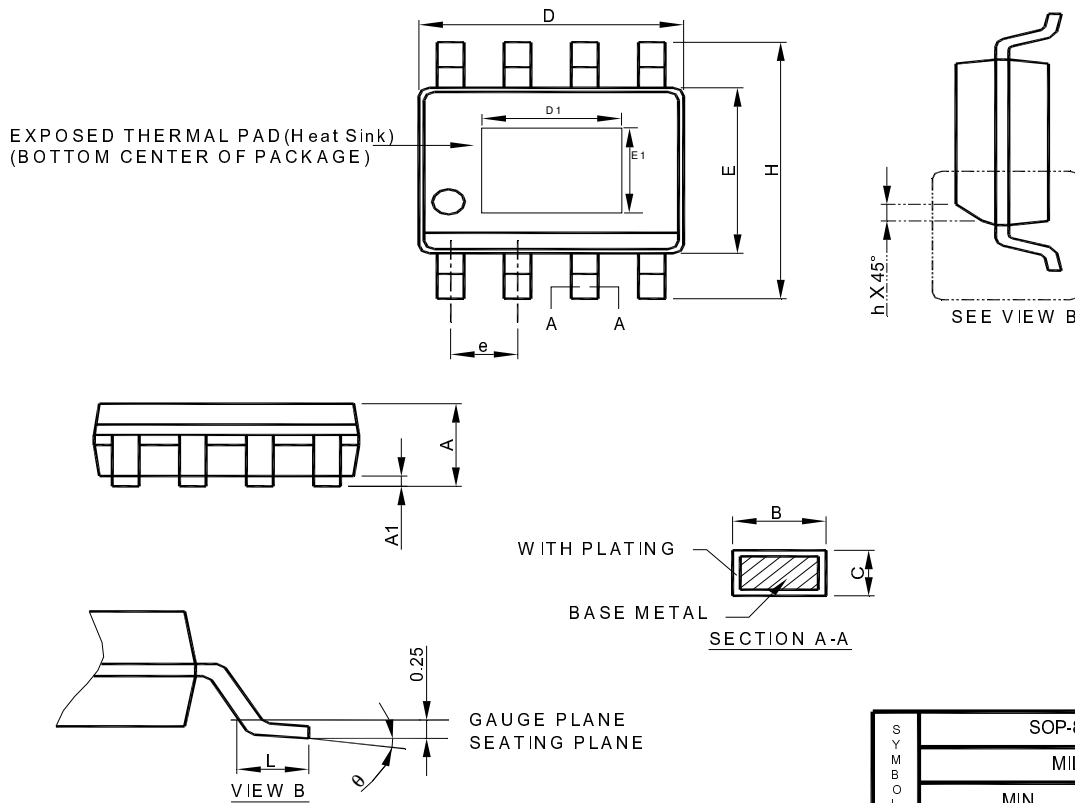

- Note :
1. Refer to JEDEC MS-012E.
 2. Dimension "D" does not include mold flash, protrusions or gate burrs. Mold flash, protrusion or gate burrs shall not exceed 6 mil per side .
 3. Dimension "E" does not include inter-lead flash or protrusions.
 4. Controlling dimension is millimeter, converted inch dimensions are not necessarily exact.

SYMBOL	SOP-8 Exposed Pad(Heat Sink)	
	MILLIMETERS	
	MIN.	MAX.
A	1.35	1.75
A1	0.00	0.15
B	0.31	0.51
C	0.17	0.25
D	4.80	5.00
E	3.80	4.00
e	1.27 BSC	
H	5.80	6.20
h	0.25	0.50
L	0.40	1.27
q	0°	8°
D1	1.5	3.5
E1	1.0	2.55

Note:

Information provided by AIC is believed to be accurate and reliable. However, we cannot assume responsibility for use of any circuitry other than circuitry entirely embodied in an AIC product; nor for any infringement of patents or other rights of third parties that may result from its use. We reserve the right to change the circuitry and specifications without notice.

Life Support Policy: AIC does not authorize any AIC product for use in life support devices and/or systems. Life support devices or systems are devices or systems which, (i) are intended for surgical implant into the body or (ii) support or sustain life, and whose failure to perform, when properly used in accordance with instructions for use provided in the labeling, can be reasonably expected to result in a significant injury to the user.