

PWM Step-Down Switching Controller with Shutdown

FEATURES

- Operation Voltage up to 15V
- Voltage-Mode Operation
- Fast Transient Response
- Built In Accurate 1.3V Voltage Reference
- Adjustable Over Current Protection using $R_{DS(ON)}$ No External Current Sense Resistor Required
- Low Shutdown Current
- 200KHz Free-Running Oscillator
- Built in Soft Start.

APPLICATIONS

- Notebook PC
- Advanced PC Mboards
- Information PCs
- Servers and Workstations
- PC Add-On Cards

DESCRIPTION

The AIC1401 is a high efficiency, PWM step-down, voltage-mode, switching controller. It is suitable for IA, Notebook, LCD PC and LCD monitor main power applications.

The built-in high voltage CMOS driver drives an external N-channel MOSFET for replacing the higher cost P-channel MOSFET in a standard buck topology.

The 200KHz switching frequency allows using smaller external components while maintaining high conversion efficiency. The 11MHz bandwidth and 6V/us slew rate of the error amplifier ensures the higher converter bandwidth and the fast transient response.

The AIC1401 also features over current protection. It provides adjustable over current trigger point and short-circuit protections by sensing the output current across the on resistance of the external N-channel MOSFET rather than an expensive external low value sense resistor.

ORDERING INFORMATION

AIC1401-XX

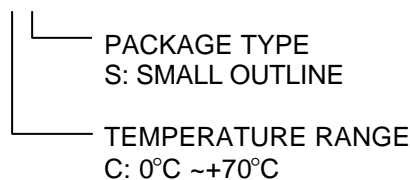

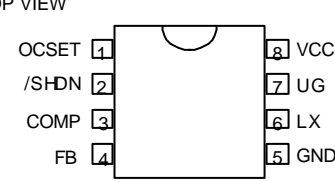
ORDER NUMBER	PIN CONFIGURATION
AIC1401CS (SOP8)	<p>TOP VIEW</p>  <p>OCSET 1 8 VCC /SHDN 2 7 UG COMP 3 6 LX FB 4 5 GND</p>

TYPICAL APPLICATION CIRCUIT

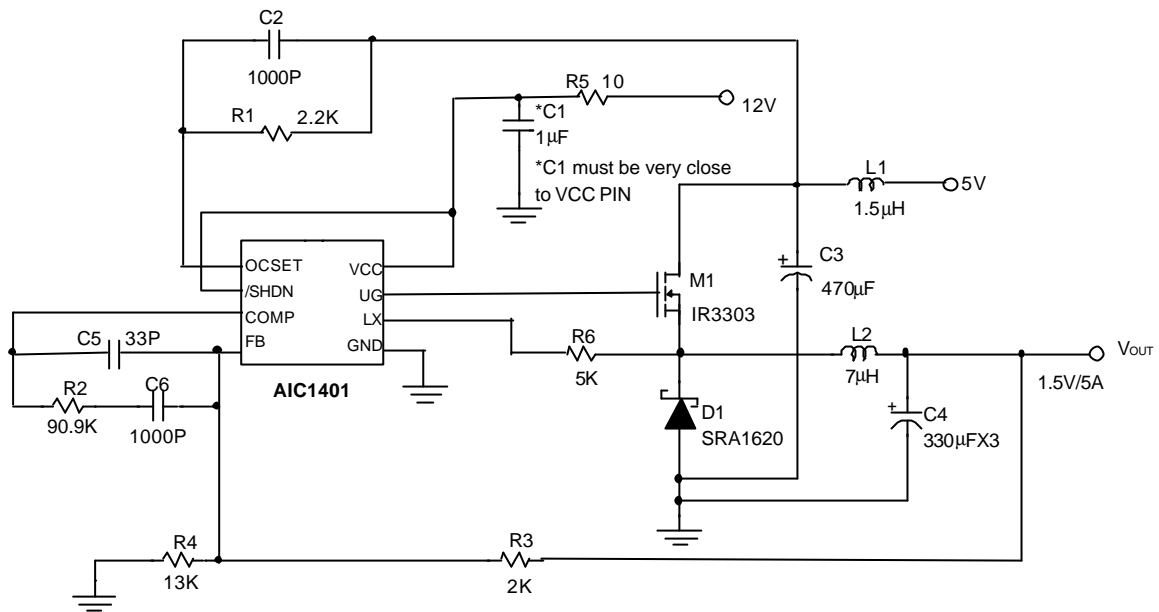

DC/DC Converter

ABSOLUTE MAXIMUM RATINGS

Supply Voltage, V_{CC}	15V
Input, Output, or I/O Voltage	GND -0.3V to $V_{CC}+0.3V$
ESD Classification	Class 2

Recommended Operating Conditions

Supply Voltage, V_{CC}	12V $\pm 10\%$
Ambient Temperature Range	0°C~70°C
Junction Temperature Range	0°C~ 100°C

Thermal Information

Thermal Resistance, θ_{JA} (Typical, Note 1)

SOIC Package	100°C/W
SOIC Package (with 3 in ² of Copper)	90°C/W
Maximum Junction Temperature (Plastic Package)	150°C
Maximum Storage Temperature Range	-65°C~150°C
Maximum Lead Temperature (Soldering 10 Sec)	300°C

Note 1: θ_{JA} is measured with the component mounted on an evaluation PC board in free air.

TEST CIRCUIT

Refer to TYPICAL APPLICATION CIRCUIT.

ELECTRICAL CHARACTERISTICS (VCC= 12V, Ta=25°C, unless otherwise specified.)

PARAMETER	TEST CONDITIONS	SYMBOL	MIN.	TYP.	MAX.	UNIT
VCC Supply Current						
Nominal Supply	UGATE Open	I_{VCC}		2		mA
Power-On Reset						
V _{CC} Threshold	V _{OCSET} =4.5V			9.5		V
Oscillator						
Frequency				200		KHz
Duty Cycle				88		%
Internal Reference Voltage						
Reference Voltage			1.27	1.30	1.33	V
Error Amplifier						
DC Gain				76		dB
Gain-Bandwidth Product		GBW		11		MHz
Slew Rate		SR		6		V/μS
Gate Driver						
Upper Gate Source		R _{UGATE}		7		Ω
Upper Gate Sink		R _{UGATE}		5		Ω
Protection						
OCSET Current Source	V _{OCSET} =4.5VDC	I _{OCSET}		200		μA
SS Current		I _{SS}		10		μA
Shutdown						
Shutdown Low Input		V _{INL}		0.35		V
Shutdown High Input		V _{INH}	2			V
Shutdown Mode Current					1	μA

■ PIN DESCRIPTIONS

PIN 1: OCSET- Current limit sense pin. Connect a resistor R_{OCSET} from this pin to the drain of the external MOSFET. R_{OCSET} , an internal $200\mu A$ current source (I_{OCSET}), and the external MOSFET on-resistance ($R_{DS(ON)}$) jointly set the overcurrent trip point according to the following equation:

$$I_{PEAK} = \frac{I_{OCSET} \times R_{OCSET}}{R_{DS(ON)}}$$

If FB pin voltage is sensed to be below 50% of the internal voltage reference, the overcurrent comparator cycles the soft-start function.

PIN 2: /SHDN - Shutdown pin. Connect this pin to ground for shutdown.

PIN 3: COMP - External compensation pin. This pin is connected to error amplifier output and PWM

comparator. A RC network is connected to FB pin to compensate the voltage-control feedback loop of the converter.

PIN 4: FB - The error amplifier inverting input pin. The FB pin and COMP pin are used to compensate the voltage-control feedback loop.

PIN 5: GND - Ground pin.

PIN 6: LX - Overcurrent detection pin. Connect the LX pin to source of the external N-MOSFET. This pin detects the voltage drop across the MOSFET $R_{DS(ON)}$ for overcurrent protection.

PIN 7: UG - External MOSFET gate drive pin. Connect this pin to gate of the external MOSFET.

PIN 8: VCC - The chip power supply pin. Recommended supply voltage is 12V.

■ APPLICATION CIRCUIT

Refer to TYPICAL APPLICATION CIRCUIT

PHYSICAL DIMENSIONS

- 8 LEAD PLASTIC SO (unit: mm)

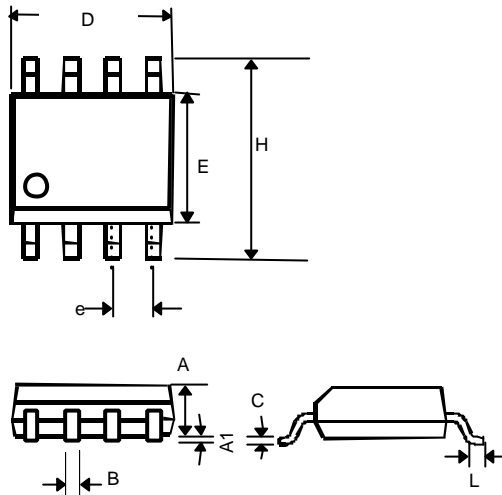

SYMBOL	MIN	MAX
A	1.35	1.75
A1	0.10	0.25
B	0.33	0.51
C	0.19	0.25
D	4.80	5.00
E	3.80	4.00
e	1.27(TYP)	
H	5.80	6.20
L	0.40	1.27