

FEATURES

- 3V to 30V Input Voltage Operation.
- Internal 2A Peak Current Switch.
- 1.5A Continuous Output Current.
- Bootstrapped Driver.
- High Side Current Sense Capability.
- High Efficiency (up to 90%).
- Internal $\pm 2\%$ Reference.
- Low Quiescent Current at 1.6mA.
- Frequency Operation from 100Hz to 100KHz.

APPLICATIONS

- Constant Current Source for Battery Chargers.
- Saver for Cellular phones.
- Step-Down DC-DC Converter Module.

DESCRIPTION

The AIC1563 is a monolithic control circuit containing the primary functions required for DC to DC converters and highside-sensed constant current source. The device consists of an internal temperature compensated reference, comparator, controlled duty cycle oscillator with an active current sense circuit, bootstrapped driver, and high current output switch. This device is specifically designed to construct a constant current source for battery chargers with a minimum number of external components. Bootstrapped driver can drive the NPN output switch to saturation for higher efficiency and less heat dissipation.

TYPICAL APPLICATION CIRCUIT

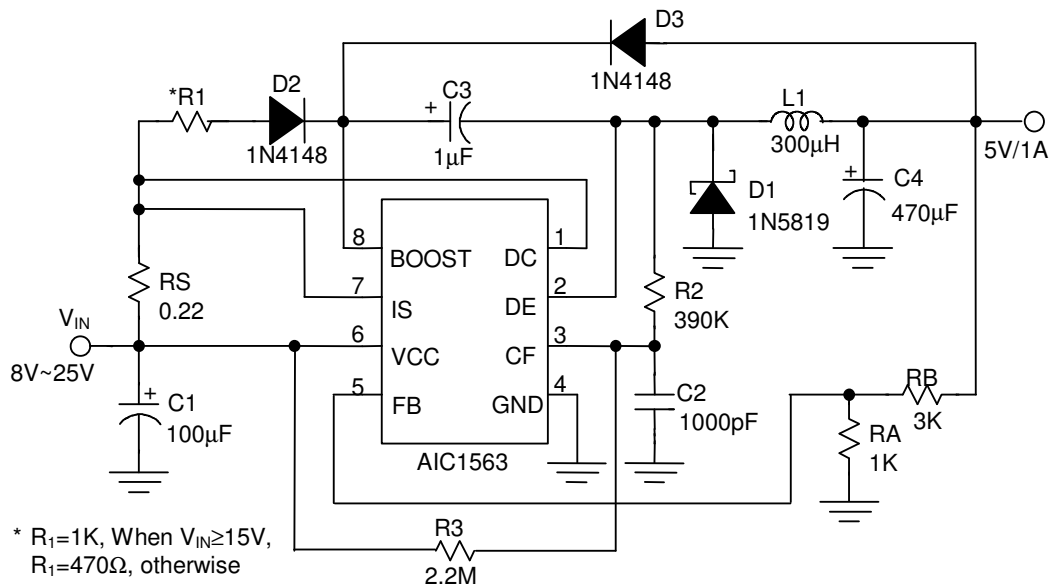

Line Regulation	$V_{IN} = 10V \sim 20V @ I_O = 1A$	40mV
Load Regulation	$V_{IN} = 15V, @ I_O = 100mA \sim 1A$	20mV
Short Circuit Current	$V_{IN} = 15V, @ R_L = 0.1\Omega$	1.3A

Step-Down Converter

ORDERING INFORMATION

AIC1563-XXX XX

PACKING TYPE
 TR: TAPE & REEL
 TB: TUBE
 (DIP is not available in TR packing)
 PACKAGING TYPE
 N: DIP-8
 S: SOP-8
 SH: SOP-8 Exposed Pad
 C: COMMERCIAL
 P: LEAD FREE COMMERCIAL
 G: GREEN PACKAGE

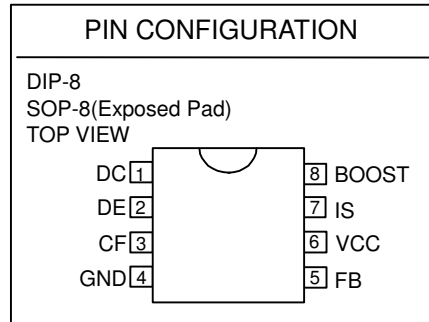

Example: AIC1563CSTR
 → in SOP-8 Package & Taping & Reel Packing Type
 AIC1563PSTR
 → in SOP-8 Lead Free Package & Taping & Reel Packing Type

ABSOLUTE MAXIMUM RATINGS

Supply Voltage	30V
Comparator Input Voltage Range	-0.3V~30V
Switch Collector Voltage	30V
Switch Emitter Voltage	30V
Switch Collector to Emitter Voltage	30V
Driver Collector Voltage	30V
Switch Current	2A
Thermal Resistance Junction to Case	SOP8.....	40°C/W
	SOP8 Exposed Pad*.....	16°C/W
	DIP8.....	60°C/W
Thermal Resistance Junction to Ambient	SOP8.....	160°C/W
(Assume no ambient airflow, no heatsink)	SOP8 Exposed Pad*.....	60°C/W
	DIP8.....	100°C/W
Operating Junction Temperature	125°C
Operating Ambient Temperature Range	-40~85°C
Storage Temperature Range	- 65°C ~ 150°C
Lead Temperature (Soldering 10 Sec.)	260°C

Absolute Maximum Ratings are those values beyond which the life of a device may be impaired.

* The package is place on a two layers PCB with 2 ounces copper and 2 square inch, connected by 8 vias.

■ TEST CIRCUIT

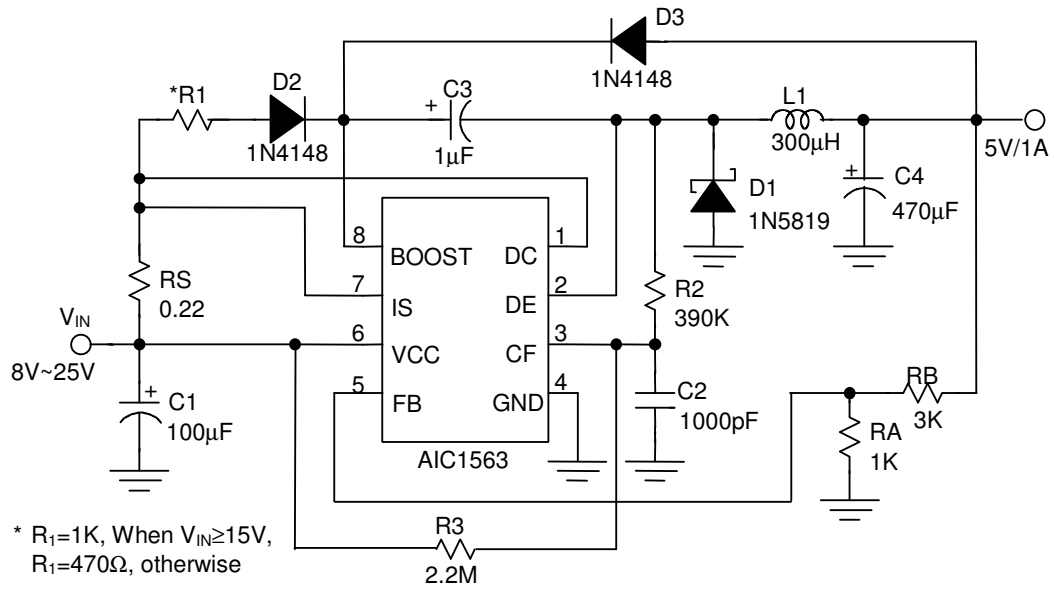

ELECTRICAL CHARACTERISTICS ($V_{CC}=5V$, $T_A=25^{\circ}C$, unless otherwise specified.)
 (Note1)

PARAMETER	TEST CONDITIONS	SYMBOL	MIN.	TYP.	MAX.	UNIT
Oscillator						
Charging Current	$5.0V \leq V_{CC} \leq 30V$	I_{CHG}	10	25	40	μA
Discharge Current	$5.0V \leq V_{CC} \leq 30V$	I_{DISCHG}	100	150	200	μA
Voltage Swing	PIN 3	V_{OSC}		0.6		V
Discharge to Charge Current Ratio	$V_{IS} = V_{CC}$	I_{DISCHG} / I_{CHG}		6.0		
Current Limit Sense Voltage	$I_{CHG} = I_{DISCHG}$	$V_{CC} - V_{IS}$	250	300	350	mV
Output Switch						
Saturation Voltage, Emitter Follower Connection	$I_{DE} = 1.0A$; $V_{BOOST} = V_{DC} = V_{CC}$	$V_{CE(SAT)}$		1.5	1.8	V
Saturation Voltage	$I_{DC} = 1.0A$; $I_{BOOST} = 50mA$, (Forced $\beta \approx 20$)	$V_{CE(SAT)}$		0.4	0.7	V
DC Current Gain	$I_{SC} = 1.0A$; $V_{CE} = 5.0V$	h_{FE}	35	120		
Collector Off-State Current	$V_{CE} = 30V$	$I_{C(OFF)}$		10		nA
Comparactor						
Threshold Voltage	$T_A = 25^{\circ}C$ $0^{\circ}C \leq T_A \leq 70^{\circ}C$	V_{FB}	1.225	1.25	1.275	V
			1.21		1.29	V
Threshold Voltage Line Regulation	$3.0V \leq V_{CC} \leq 30V$	REGLINE		0.1	0.3	mV/V
Input Bias Current	$V_{IN} = 0V$	I_{IB}		0.4	1	μA
Supply Current	$V_{IS} = V_{CC}$, pin 5 > V_{FB} $5.0V \leq V_{CC} \leq 30V$ $C_T = 1nF$ PIN 2=GND Remaining pins open	I_{CC}		1.6	3	mA

Note 1: Specifications are production tested at $T_A = 25^{\circ}C$. Specifications over the $-40^{\circ}C$ to $85^{\circ}C$ operating temperature range are assured by design, characterization and correlation with Statistical Quality Controls (SQC).

TYPICAL PERFORMANCE CHARACTERISTICS

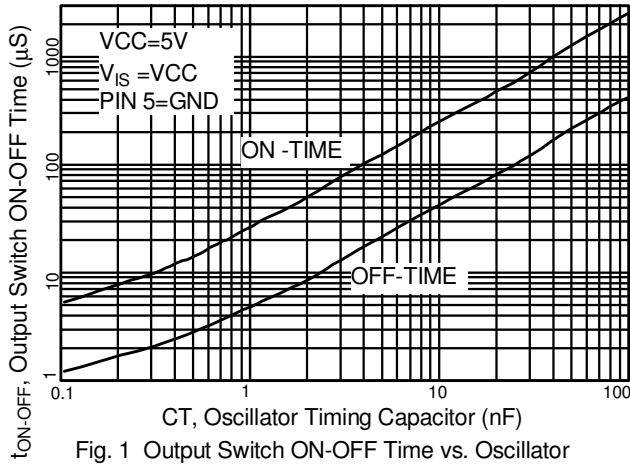

Fig. 1 Output Switch ON-OFF Time vs. Oscillator Timing Capacitor

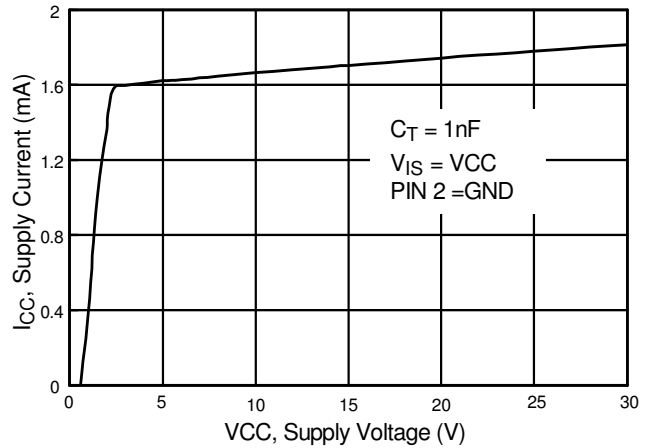

Fig. 2 Standby Supply Current vs. Supply Voltage

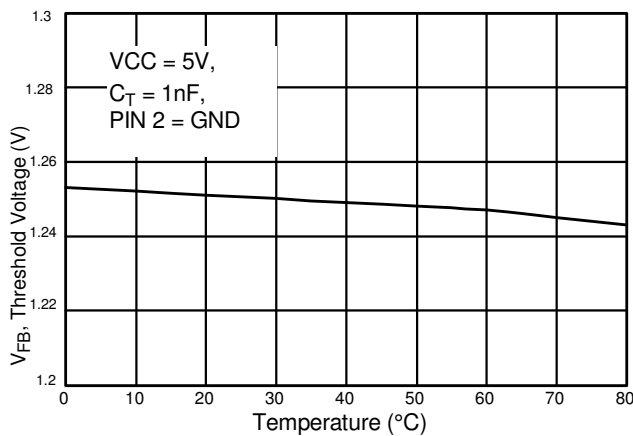

Fig. 3 V_{FB} , Threshold Voltage vs. Temperature

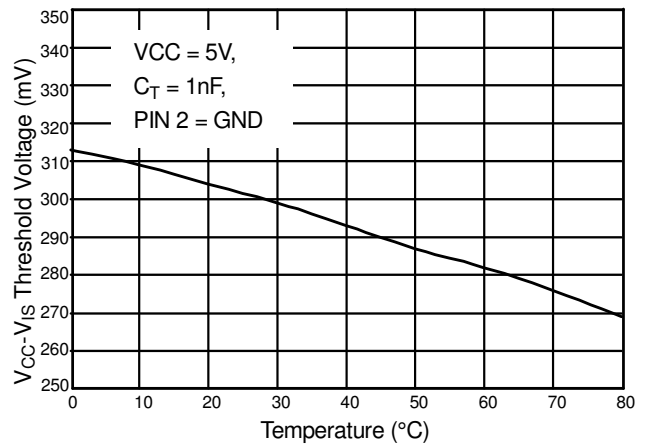

Fig. 4 I_S Threshold Voltage vs. Temperature

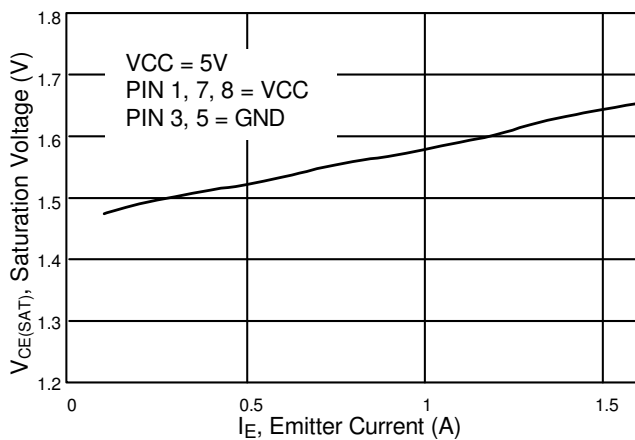

Fig. 5 Emitter Follower Configuration Output Switch Saturation Voltage vs. Emitter Current

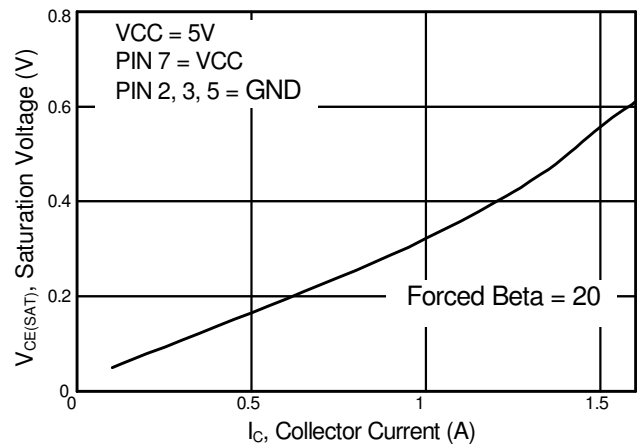
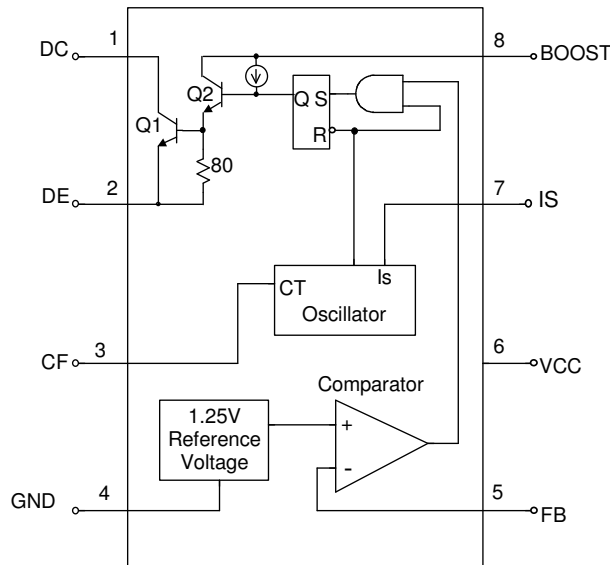

Fig. 6 Common Emitter Configuration Output Switch Saturation Voltage vs. Collector Current

■ BLOCK DIAGRAM



■ PIN DESCRIPTIONS

- PIN 1: DC - The switch collector is 2A.
- PIN 2: DE - Darlington switch emitter.
- PIN 3: CF - Oscillator timing capacitor.
- PIN 4: GND - Power ground.

- PIN 5: FB - Feedback comparator inverting input.
- PIN 6: VCC - Power supply input.
- PIN 7: IS - Highside current sense input.
VCC - $V_{IS}=300mV$.
- PIN 8: BOOST-Bootstrapped driver collector.

■ APPLICATION INFORMATION

● DESIGN FORMULA TABLE

CALCULATION	STEP-DOWN	STEP-UP
$\frac{t_{ON}}{t_{OFF}}$	$\frac{V_{OUT} + V_F}{V_{IN(MIN)} - V_{SAT} - V_{OUT}}$	$\frac{V_{OUT} + V_F - V_{IN(MIN)}}{V_{IN(MIN)} - V_{SAT}}$
$(t_{ON} + t_{OFF})_{MAX}$	$\frac{1}{F_{MIN}}$	$\frac{1}{F_{MIN}}$
C_T	$4 \times 10^{-5} t_{ON}$	$4 \times 10^{-5} t_{ON}$
$I_{C(SWITCH)}$	$2I_{OUT(MAX)}$	$2I_{OUT(MAX)} \left(\frac{t_{ON} + t_{OFF}}{t_{OFF}} \right)$
RS	$\frac{0.9 \times V_{CURRENT SENSE(min.)}}{I_{C(SWITCH)}} = \frac{225mV}{I_{C(SWITCH)}}$	$\frac{0.9 \times V_{CURRENT SENSE(min.)}}{I_{C(SWITCH)}} = \frac{225mV}{I_{C(SWITCH)}}$
L(MIN)	$\left(\frac{V_{IN(MIN)} - V_{SAT} - V_{OUT}}{I_{C(SWITCH)}} \right) t_{ON(MAX)}$	$\left(\frac{V_{IN(MIN)} - V_{SAT}}{I_{C(SWITCH)}} \right) t_{ON(MAX)}$
Co	$\frac{I_{C(SWITCH)} (t_{ON} + t_{OFF})}{8V_{RIPPLE(P-P)}}$	$\frac{I_{OUT} t_{ON}}{V_{RIPPLE(P-P)}}$

V_{SAT} = Saturation voltage of the output switch.
 V_F = Forward voltage of the ringback rectifier

The following power supply characteristics must be chosen:

V_{IN} - Nominal input voltage.
 V_{OUT} - Desired output voltage,
 $V_{OUT} = 1.25 (1 + RB/RA)$
 I_{OUT} - Desired output current.

F_{MIN} - Minimum desired switching frequency at selected values for V_{IN} and I_{OUT} .

$V_{RIPPLE(P-P)}$ - Desired peak-to-peak output ripple voltage. In practice, the calculated value will need to be increased due to the capacitor equivalent series resistance and board layout. The ripple voltage should be kept to a low value since it will directly affect the line and load regulation.

● LAYOUT GUIDANCE FOR EP THERMAL PATH

The AIC1563 uses a thermally-enhanced SOP8 package that has an exposed thermal pad at the bottom side of the package. The layout should connect as much as possible to copper on the exposed pad. Typically the component layer is more effective in dissipating heat. The thermal imped-

ance can be further reduced by using other layers of copper connecting to the exposed pad through a thermal via array. Each thermal via is recommended to have 0.3mm diameter and 1mm distance from other thermal vias.

APPLICATION EXAMPLES

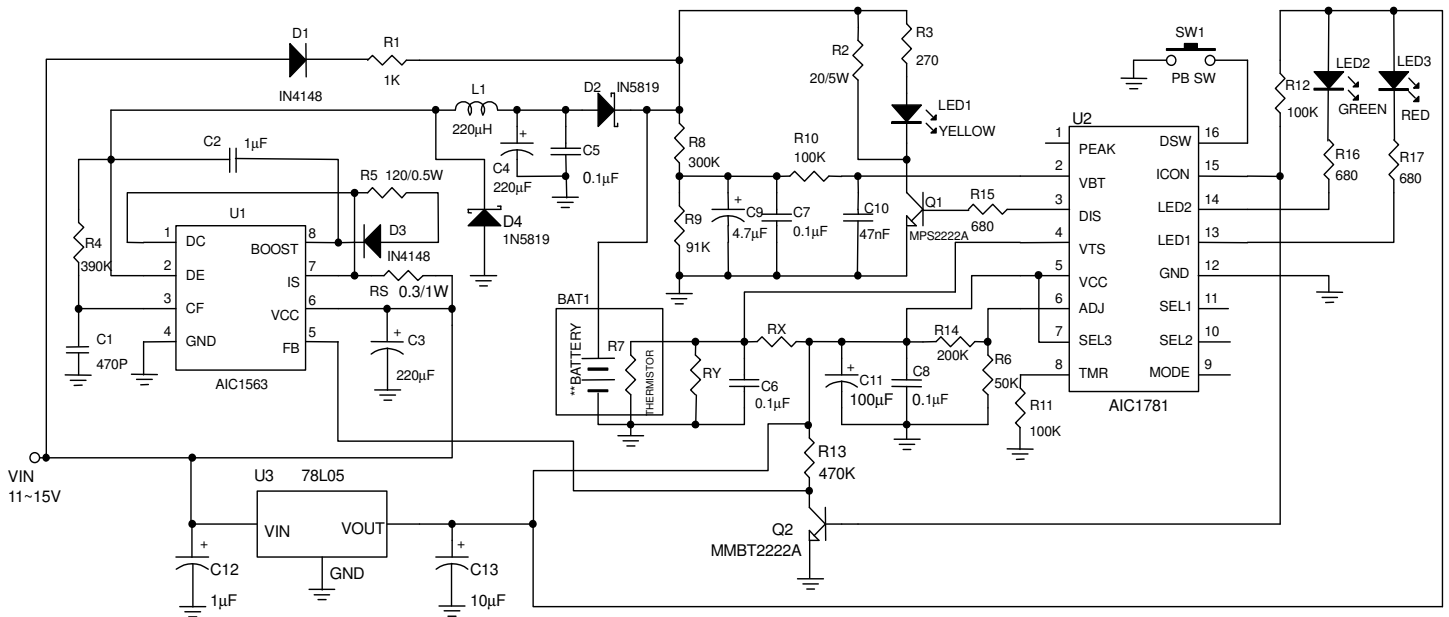

**3~5 NiMH/NiCd cells.
 Note: Charge Current=0.3/RS Ampere
 Safety Timer: 80min

Fig. 7 Battery Charge Circuit for Fluctuating Charging Current Applications

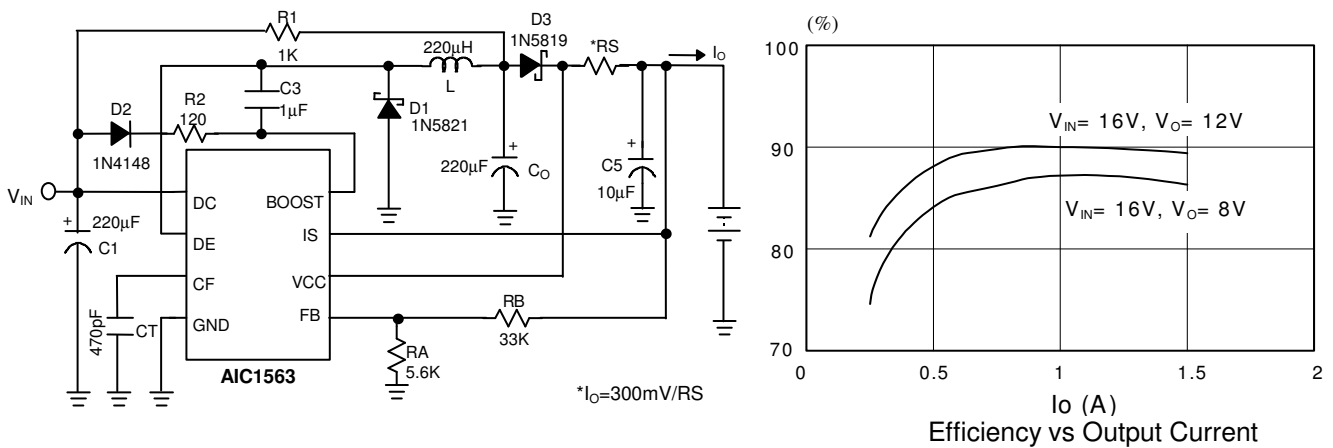

Fig. 8 Battery Charge Circuit

■ APPLICATION EXAMPLES (Continued)

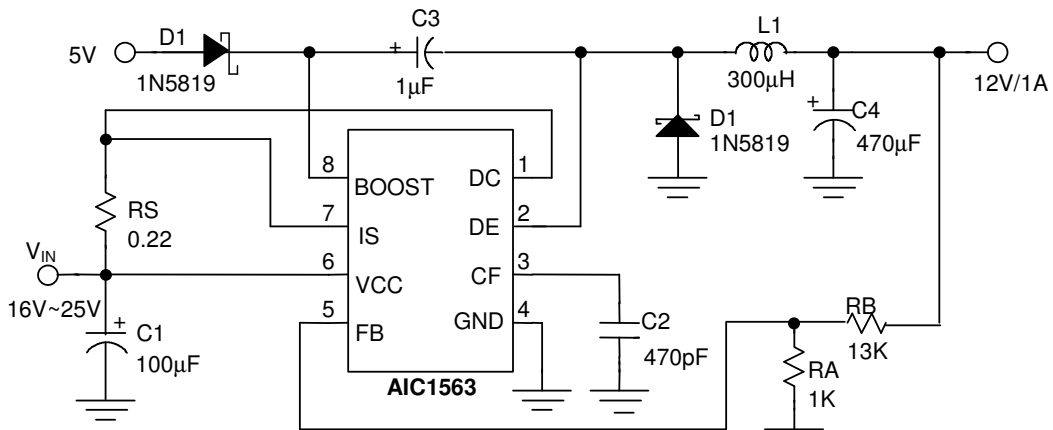
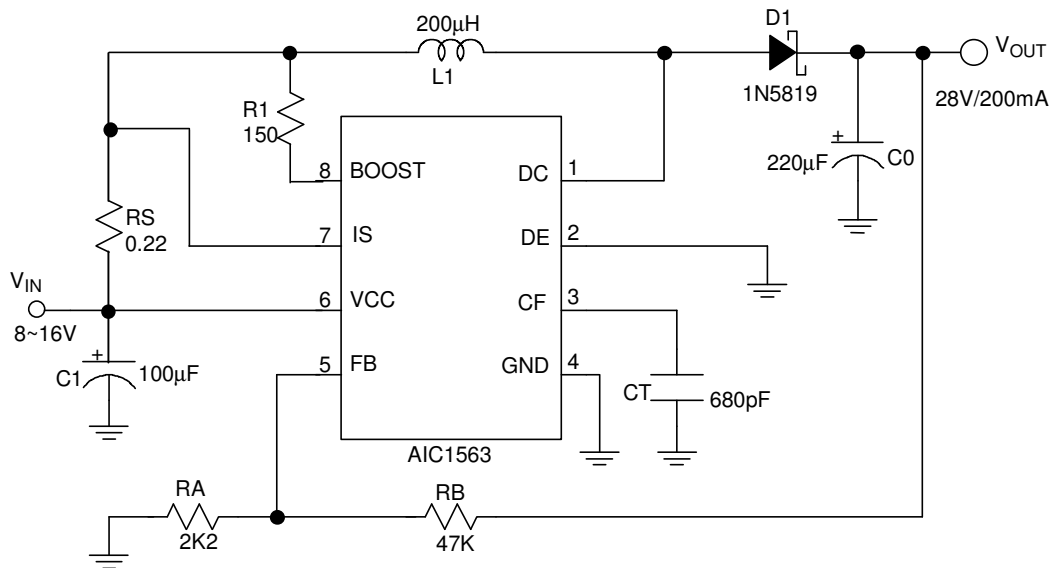

Fig. 9 Step-Down Converter with External 5V Bootstrap



Line Regulation	$V_{IN} = 8V \sim 16V @ I_O = 200mA$	100mV
Load Regulation	$V_{IN} = 12V, @ I_O = 80mA \sim 200mA$	40mV

Fig. 10 Step-Up Converter

■ APPLICATION EXAMPLES (Continued)

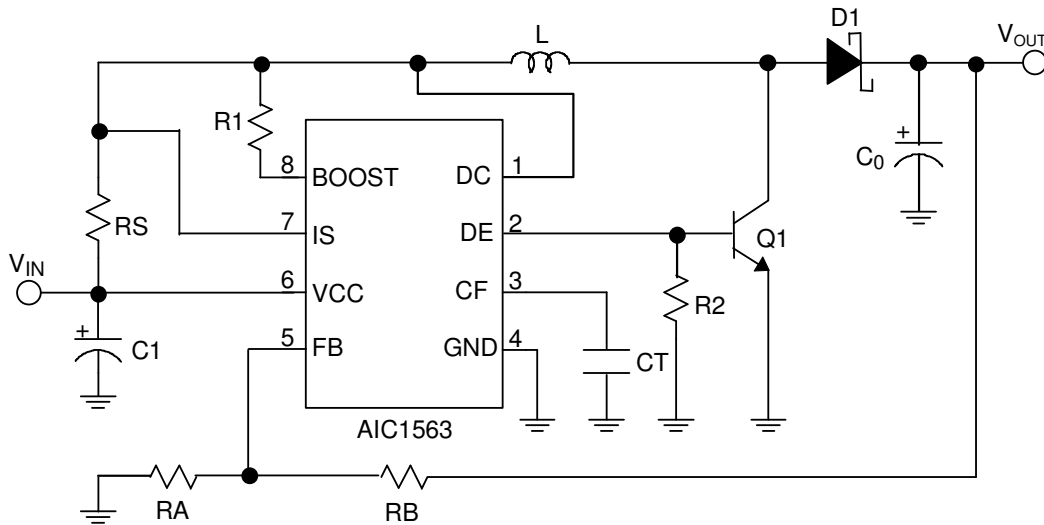
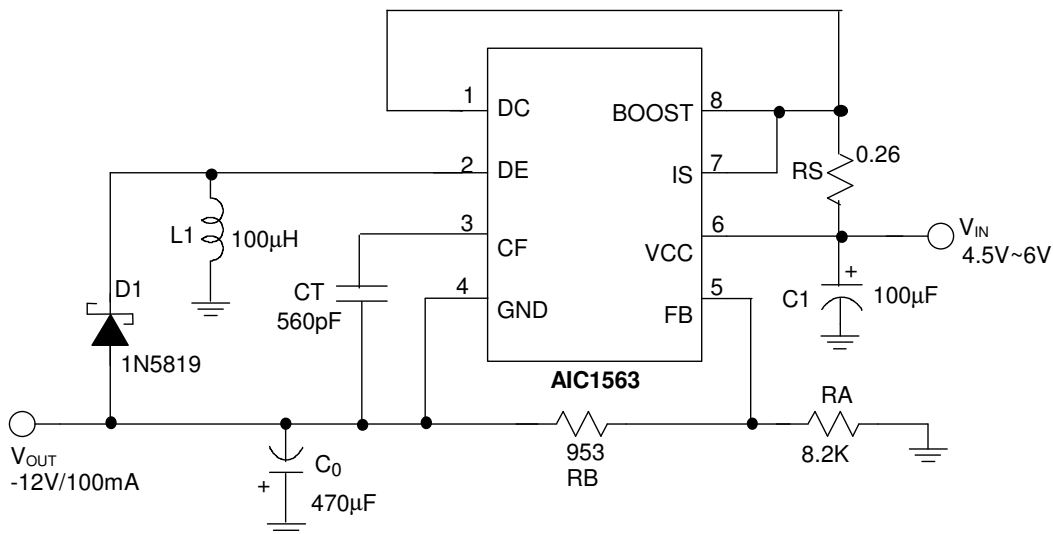

Fig. 11 Step-Up Converter with External NPN Switch



Line Regulation	$V_{IN} = 4.5V \sim 6V @ I_O = 100mA$	20mV
Load Regulation	$V_{IN} = 5V, @ I_O = 10mA \sim 100mA$	100mV

Fig. 12 Inverting Converter

■ APPLICATION EXAMPLES (Continued)

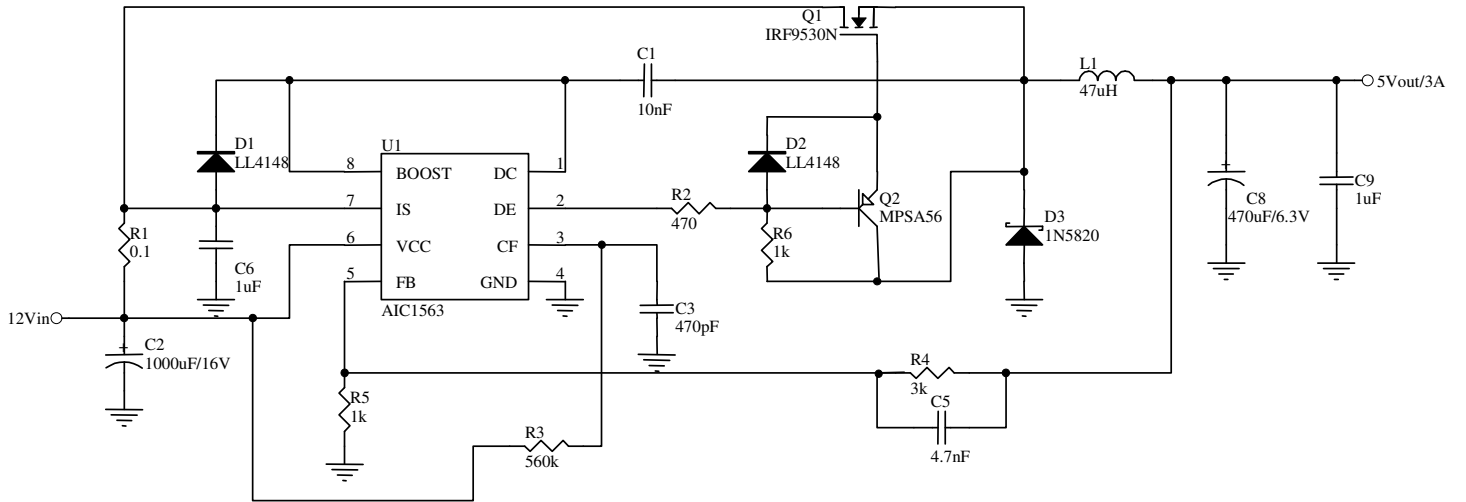

Fig. 13 Step-down Converter with External N-MOS Switch

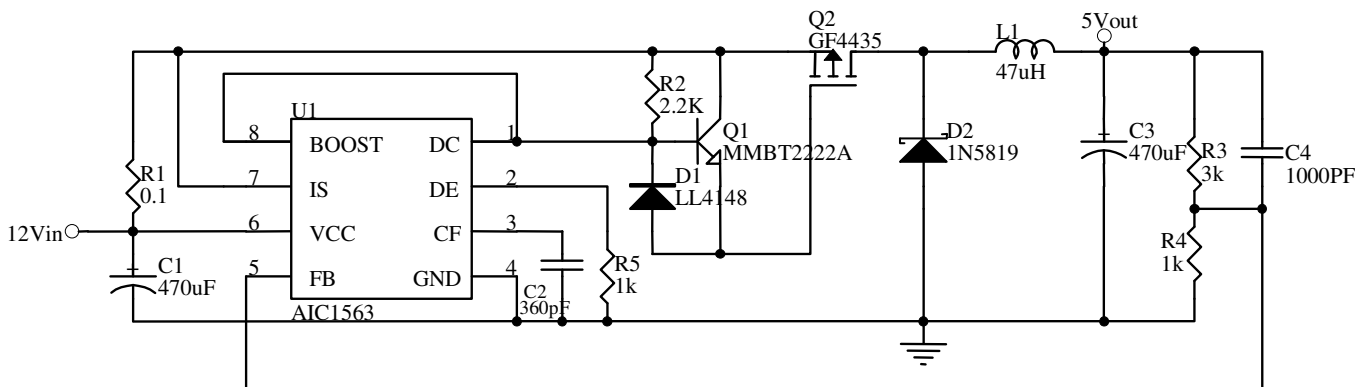
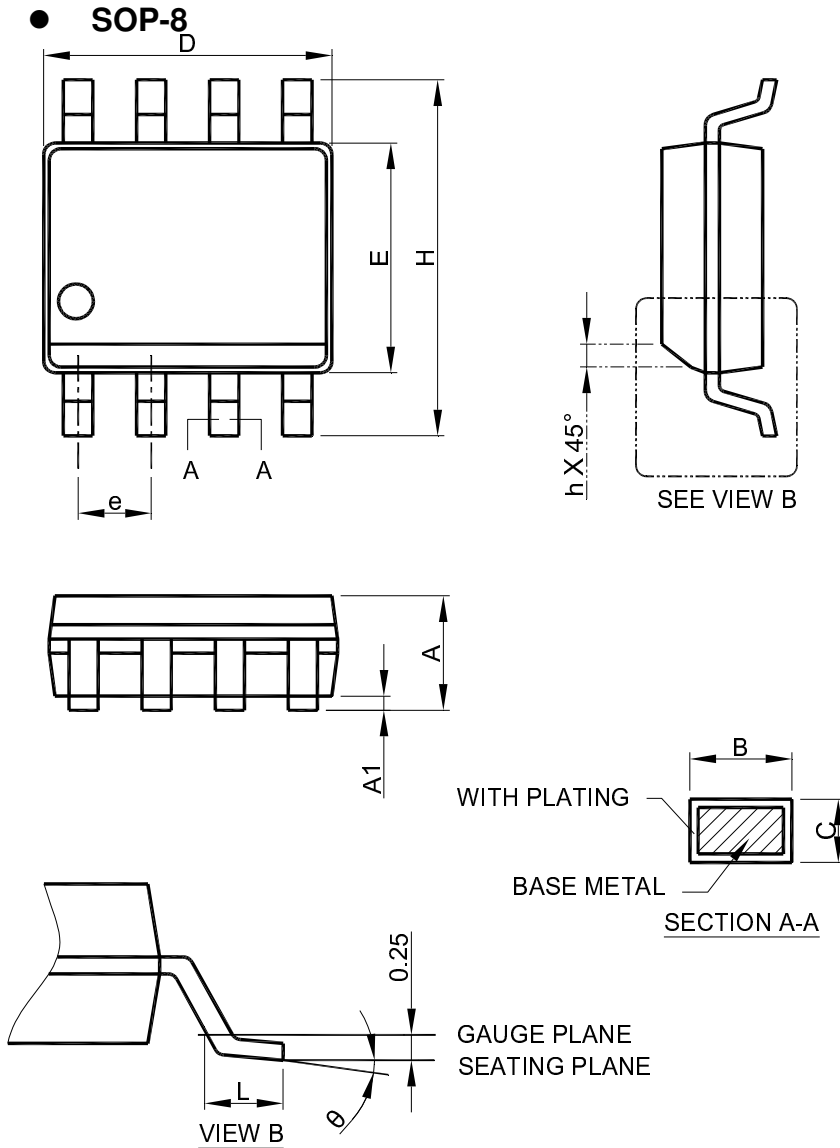

Fig. 14 Step-down Converter with External P-MOS Switch

■ PHYSICAL DIMENSIONS (unit: mm)



- Note: 1. Refer to JEDEC MS-012AA.
 2. Dimension "D" does not include mold flash, protrusions or gate burrs. Mold flash, protrusion or gate burrs shall not exceed 6 mil per side .
 3. Dimension "E" does not include inter-lead flash or protrusions.
 4. Controlling dimension is millimeter, converted inch dimensions are not necessarily exact.

SYMBOL	SOP-8	
	MILLIMETERS	
	MIN.	MAX.
A	1.35	1.75
A1	0.10	0.25
B	0.33	0.51
C	0.19	0.25
D	4.80	5.00
E	3.80	4.00
e	1.27 BSC	
H	5.80	6.20
h	0.25	0.50
L	0.40	1.27
θ	0°	8°

● SOP-8 (Exposed Pad)

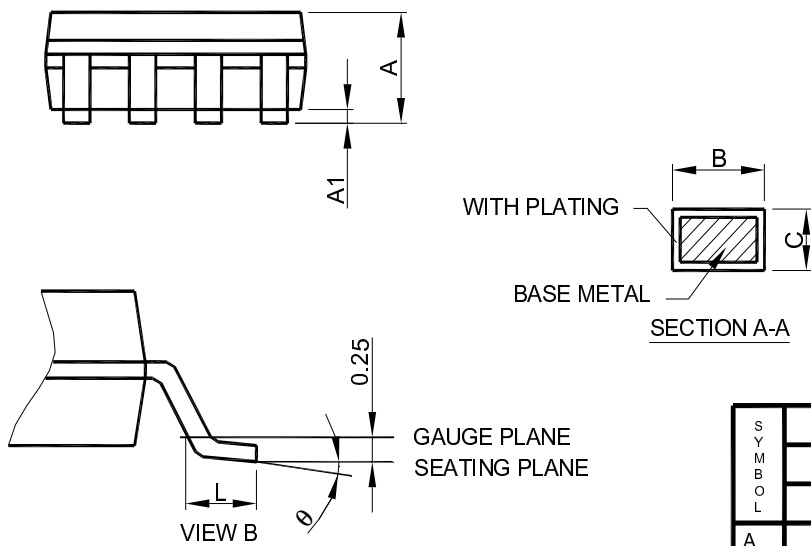
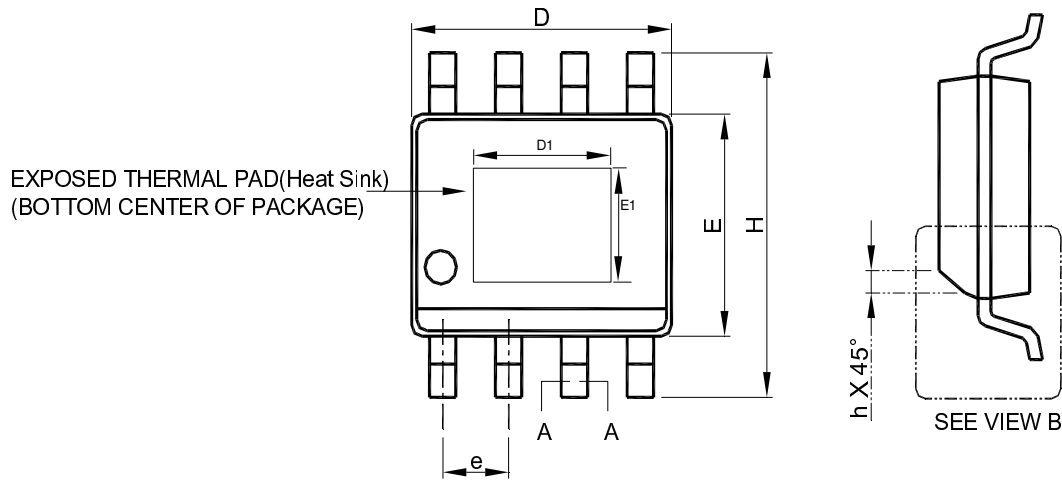

- Note :
1. Refer to JEDEC MS-012E.
 2. Dimension "D" does not include mold flash, protrusions or gate burrs. Mold flash, protrusion or gate burrs shall not exceed 6 mil per side .
 3. Dimension "E" does not include inter-lead flash or protrusions.
 4. Controlling dimension is millimeter, converted inch dimensions are not necessarily exact.

SYMBOL	SOP-8 Exposed Pad(Heat Sink)	
	MILLIMETERS	
	MIN.	MAX.
A	1.35	1.75
A1	0.00	0.15
B	0.31	0.51
C	0.17	0.25
D	4.80	5.00
E	3.80	4.00
e	1.27 BSC	
H	5.80	6.20
h	0.25	0.50
L	0.40	1.27
q	0°	8°
D1	1.5	3.5
E1	1.0	2.55

● DIP-8

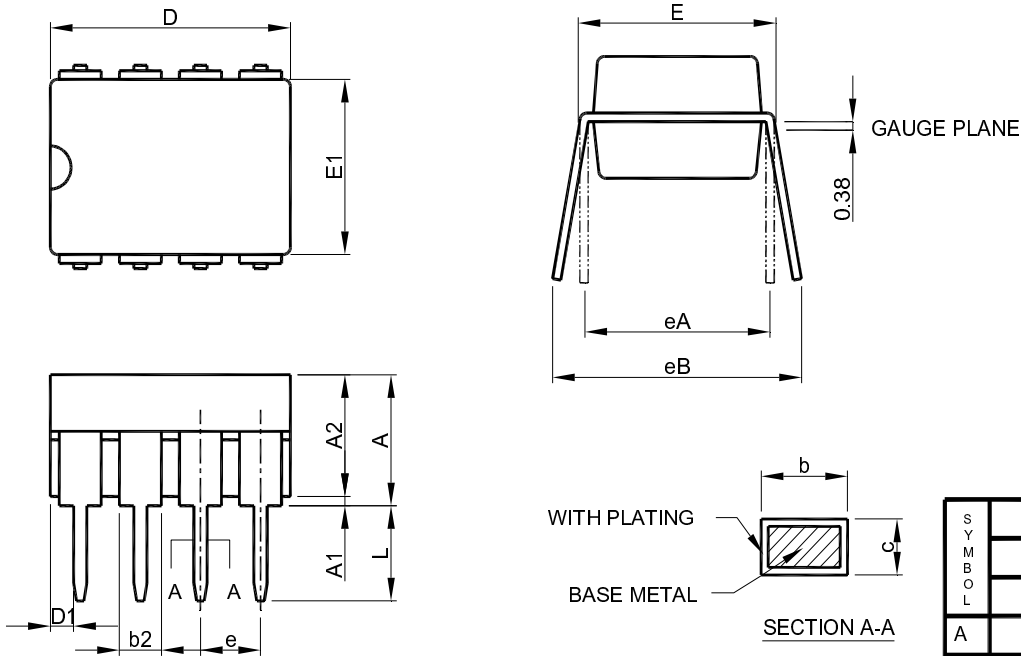

SYMBOL	DIP-8	
	MILLIMETERS	
	MIN.	MAX.
A		5.33
A1	0.38	
A2	2.92	4.95
b	0.36	0.56
b2	1.14	1.78
c	0.20	0.35
D	9.01	10.16
D1	0.13	
E	7.62	8.26
E1	6.10	7.11
e	2.54 BSC	
eA	7.62 BSC	
eB		10.92
L	2.92	3.81

- Note: 1. Refer to JEDEC MS-001BA
 2. Dimension "D" does not include mold flash, protrusions or gate burrs. Mold flash, protrusion or gate burrs shall not exceed 10 mil per side .
 3. Dimension "D1" and "E1" do not include inter-lead flash or protrusions.
 4. Controlling dimension is millimeter, converted inch dimensions are not necessarily exact.

Note:

Information provided by AIC is believed to be accurate and reliable. However, we cannot assume responsibility for use of any circuitry other than circuitry entirely embodied in an AIC product; nor for any infringement of patents or other rights of third parties that may result from its use. We reserve the right to change the circuitry and specifications without notice.

Life Support Policy: AIC does not authorize any AIC product for use in life support devices and/or systems. Life support devices or systems are devices or systems which, (i) are intended for surgical implant into the body or (ii) support or sustain life, and whose failure to perform, when properly used in accordance with instructions for use provided in the labeling, can be reasonably expected to result in a significant injury to the user.