

## 4-bit DAC, Simple PWM Power Regulator

### ■ FEATURE

- Compatible with HIP6008.
- Simple Voltage-Mode PWM Control.
- Fast Transient Response.
- $\pm 1.5\%$  4-Bit Digital-to-Analog Output Voltage.
- Adjustable Current Limit without External Sense Resistors.
- Full 0% to 100% Duty Ratio.
- 200KHz Free-Running Oscillator, Programmable up to 350KHz.
- Power-Good Output Voltage Monitor.
- Short Circuit Protection with Low Short Circuit Output Current.

### ■ APPLICATIONS

- Power Supply for Pentium<sup>®</sup>, Pentium Pro<sup>®</sup>, Power PC<sup>®</sup> and Alpha<sup>®</sup> Microprocessors.
- High-Power 5V to 3.xV DC/DC Regulators.
- Low-Voltage Distributed Power Supplies.

### ■ DESCRIPTION

The AIC1568 is a high power, high efficiency switching regulator controller optimized for high performance microprocessor applications. It is designed to drive an N-channel MOSFET in a standard buck topology. Featuring a digitally programmable switching regulator, the AIC1568 includes monitoring and protection capabilities in addition to all the essential PWM control functions.

The internal 4-bit Digital-to-Analog Converter (DAC) adjusts the output voltage from 2.0V to 3.5V in 0.1V increments. The precision reference and voltage-mode control can provide output regulation within  $\pm 1.5\%$  over temperature and line voltage shifts.

The internal oscillator of the AIC1568 free-runs at 200KHz and can be adjusted up to 350KHz. The resulting PWM duty ratio ranges from 0% to 100%. The error amplifier features a 11MHz bandwidth and  $6V/\mu S$  slew rate, which enables high converter bandwidth for fast transient response.

The AIC1568 provides adjustable over current and short circuit protections. It senses the output current across the on resistance of the N-channel MOSFET without an external low value sense resistor. It also monitors the output voltage with a window comparator and issues a power good signal when the output is within 10% of the rated output voltage.

## ORDERING INFORMATION

AIC1568 XX

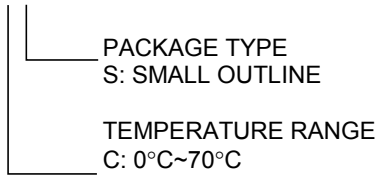

ORDER NUMBER	PIN CONFIGURATION
AIC1568CS (PLASTIC SO)	TOP VIEW
OCSET [1]	[16] VSEN
SS [2]	[15] RT/OVP
VID0 [3]	[14] VCC
VID1 [4]	[13] BOOT
VID2 [5]	[12] UGATE
VID3 [6]	[11] PHASE
COMP [7]	[10] PGOOD
FB [8]	[9] GND

## TYPICAL APPLICATION CIRCUIT

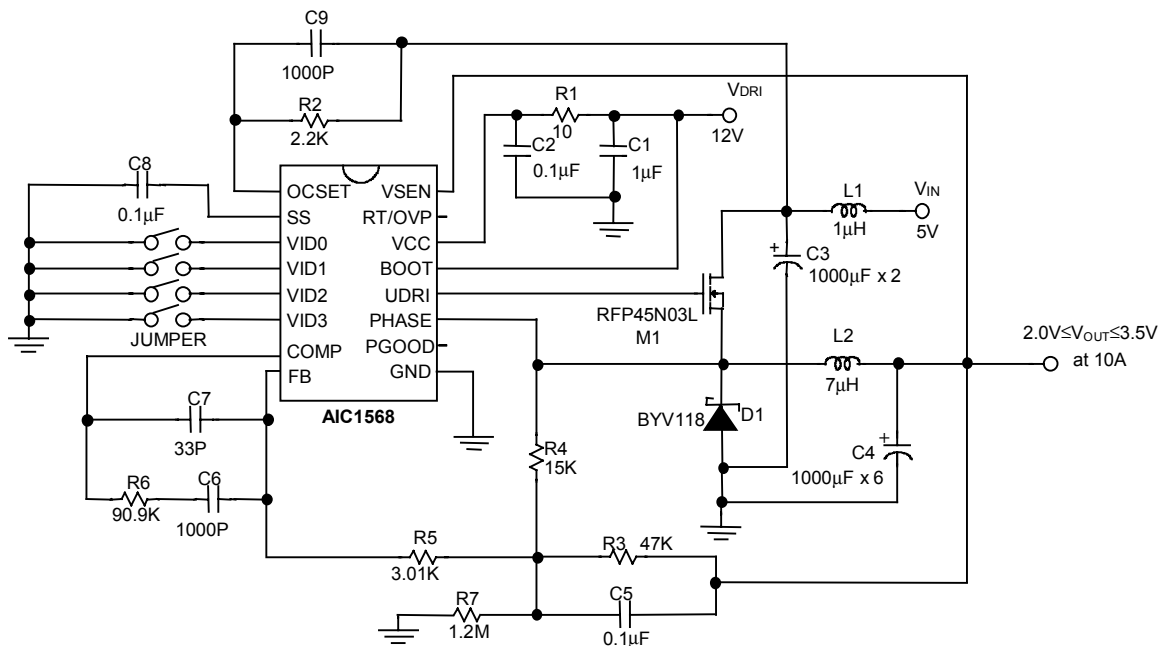

Switching Regulator for Pentium® V<sub>CORE</sub> Supply

■ **ABSOLUTE MAXIMUM RATINGS**

Supply Voltage, $V_{CC}$ .....	15V
Boot Voltage, $V_{BOOT}$ .....	15V
Input, Output, or I/O Voltage .....	GND - 0.3V to $V_{CC}+0.3V$
ESD Classification .....	Class 2

**Recommended Operating Conditions**

Supply Voltage, $V_{CC}$ .....	12V±10%
Ambient Temperature Range .....	0°C ~ 70°C
Junction Temperature Range .....	0°C ~100°C

**Thermal Information**

Thermal Resistance, $\theta_{JA}$ (Typical, Note 1)	
SOIC Package .....	100°C/W
SOIC Package (with 3 in <sup>2</sup> of Copper) .....	90°C /W
Maximum Junction Temperature (Plastic Package) .....	150°C
Maximum Storage Temperature Range .....	-65°C ~150°C
Maximum Lead Temperature (Soldering 10 Sec) .....	300°C

*Note 1:  $\theta_{JA}$  is measured with the component mounted on an evaluation PC board in free air.*

■ **TEST CIRCUIT**

Refer to TYPICAL APPLICATION CIRCUIT.

**ELECTRICAL CHARACTERISTICS** ( $V_{CC}= 12V$ ,  $T_a=25^{\circ}C$ , unless otherwise specified.)

PARAMETER	TEST CONDITIONS	SYMBOL	MIN.	TYP.	MAX.	UNIT
<b>VCC Supply Current</b>						
Nominal Supply	$U_{GATE}$ Open	$I_{VCC}$		2		mA
<b>Power-On Reset</b>						
$V_{CC}$ Threshold	$V_{OCSET}=4.5V$			7	8.5	V
Rising $V_{OCSET}$ Threshold				1.26		V
<b>Oscillator</b>						
Free Running Frequency	RT Open		170	200	230	KHz
Total Variation	$6K\Omega < R_T < 200K\Omega$		-20		+20	%
Ramp Amplitude	RT Open	$\Delta V_{OSC}$		1.5		$V_{P-P}$
<b>DAC Output Voltage</b>						
DAC Output Voltage Accuracy			-1.5		+1.5	%
<b>Error Amplifier</b>						
DC Gain				76		dB
Gain-Bandwidth Product		GBW		11		MHz
Slew Rate		SR		6		$V/\mu S$
<b>Gate Driver</b>						
Upper Gate Source		$R_{UGATE}$		8	12	$\Omega$
Upper Gate Sink		$R_{UGATE}$		5.5	10	$\Omega$
<b>Protection</b>						
Over-Voltage Trip ( $V_{VSEN}/VDAC$ )			106	115	125	%
OCSET Current Source	$V_{OCSET}=4.5VDC$	$I_{OCSET}$	170	200	230	$\mu A$
OVP Sourcing Current	$V_{VSEN}=5.5V, V_{OVP}=0V$	$I_{OVP}$	30			mA
SS Current		$I_{SS}$		10		$\mu A$
SS Sink Current under Current Limit	$V_{VSEN}=VDAC, V_{OCSET}=5.0V, V_{PHASE}=0V, V_{FB}=V_{DAC}-50mV$			130		$\mu A$
SS Sink Current under Hard Current Limit	$V_{VSEN}=0, V_{OCSET}=5.0V, V_{PHASE}=0V, V_{FB}=0V$			65		mA
<b>Power Good</b>						
Upper Threshold ( $V_{VSEN}/VDAC$ )	$V_{VSEN}$ rising		106		114	%
Lower Threshold ( $V_{VSEN}/VDAC$ )	$V_{VSEN}$ falling		84		94	%
Hysteresis ( $V_{VSEN}/VDAC$ )	Upper and lower threshold			2		%
PGOOD Voltage Low	$I_{PGOOD}=5mA$	$V_{PGOOD}$		0.5		V

## ■ BLOCK DIAGRAM

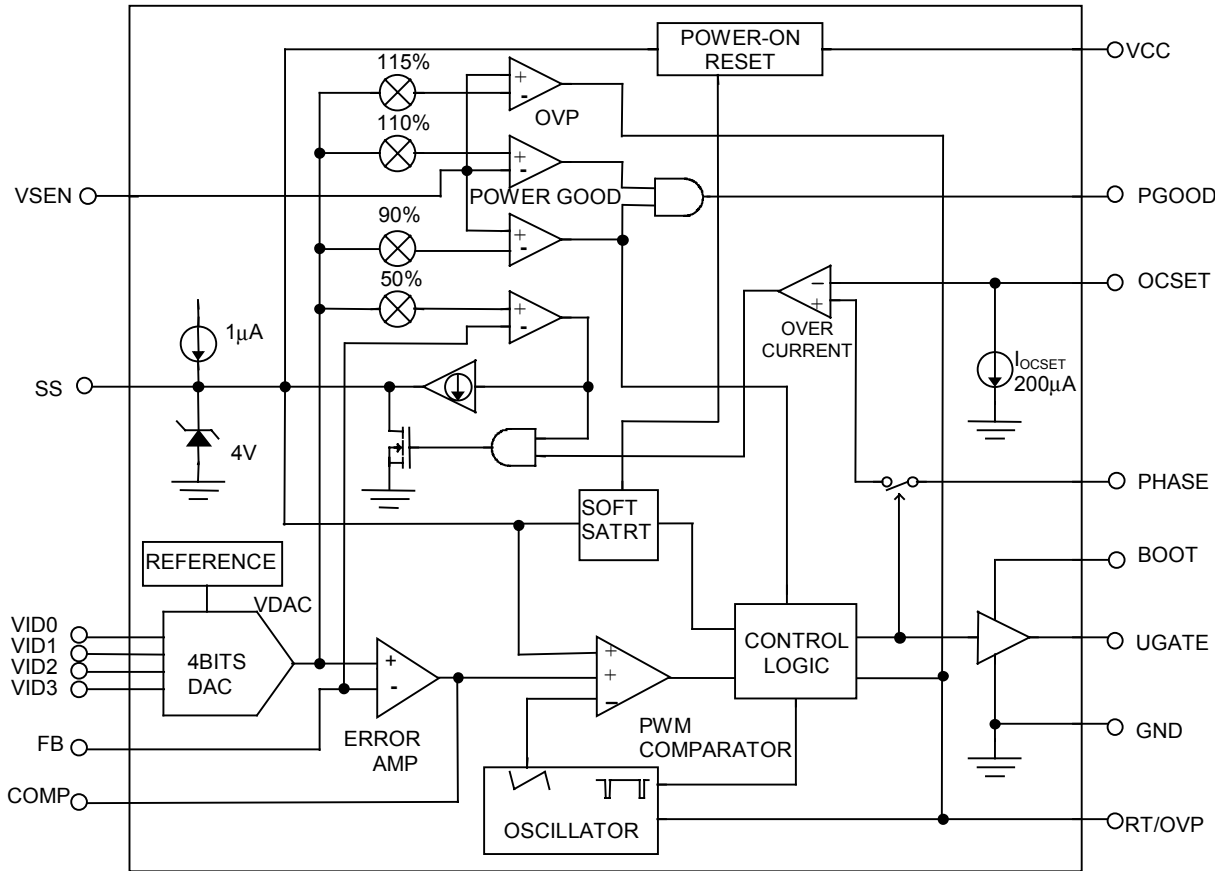

## ■ PIN DESCRIPTIONS

**PIN 1: OCSET** - Current limit sense pin. Connect a resistor  $R_{OCSET}$  from this pin to the drain of the external MOSFET.  $R_{OCSET}$ , an internal 200  $\mu$ A current source ( $I_{OCSET}$ ), and the external MOSFET on-resistance ( $R_{DS(ON)}$ ) jointly set the over current trip point according to the following equation:

$$I_{PEAK} = \frac{I_{OCSET} \times R_{OCSET}}{R_{DS(ON)}}$$

If FB pin voltage is sensed to be below 50% of the internal voltage reference VDAC, the over current comparator cycles the soft-start function.

**PIN 2: SS** - Soft start pin. Connect a capacitor from this pin to ground.

An internal 10 $\mu$ A current source provides soft start function for the converter.

**PIN 3: VID0** } -  
**PIN 4: VID1** } -  
**PIN 5: VID2** } -  
**PIN 6: VID3** } - 4-bit DAC voltage select pin. TTL inputs used to set the internal voltage reference VDAC. When left open, these pins are internally pulled up to 5V and provide logic ones. The level of VDAC sets the converter output voltage as well as the PGGOOD and OVP thresholds.

Table 1 specifies the VDAC voltage for the 16 combinations of DAC inputs.

**Table 1. Output Voltage Program**

VID0	VID1	VID2	VID3	VDAC
0	0	0	0	3.5V
1	0	0	0	3.4V
0	1	0	0	3.3V
1	1	0	0	3.2V
0	0	1	0	3.1V
1	0	1	0	3.0V
0	1	1	0	2.9V
1	1	1	0	2.8V
0	0	0	1	2.7V
1	0	0	1	2.6V
0	1	0	1	2.5V
1	1	0	1	2.4V
0	0	1	1	2.3V
1	0	1	1	2.2V
0	1	1	1	2.1V
1	1	1	1	2.0V

**PIN 7: COMP** - External compensation pin. This pin is connected to error amplifier output and PWM comparator. An RC network is connected to FB pin to compensate the voltage-control feedback loop of the converter.

**PIN 8: FB** - The error amplifier inverting input pin. The FB pin and COMP pin are used to compensate the voltage-control feedback loop.

**PIN 9: GND** - Signal GND. It also serves as the power GND for the upper gate driver.

**PIN 10: PGOOD**-Power good indicator pin. PGOOD is an open drain output. This pin is pulled low when the converter output is  $\pm 10\%$  out of the VDAC reference voltage.

**PIN 11: PHASE**- Over current detection pin. Connect

the PHASE pin to source of the external MOSFET. This pin detects the voltage drop across the MOSFET  $R_{DS(ON)}$  for over-current protection.

**PIN 12: UGATE**- External MOSFET gate drive pin. Connect this pin to gate of the external MOSFET.

**PIN 13: BOOT** - External MOSFET driver power supply pin. To convert 5V main power to  $V_{CORE}$  power by driving N-channel MOSFET, supply voltage of no higher than 12V is recommended since the negative power terminal of the internal driver is internally tied to GND.

**PIN 14: VCC** - The chip power supply pin. Recommended supply voltage is 12V.

**PIN 15: RT/OVP**- Frequency adjustment and overvoltage indicator pin. This pin is multiplexed to provide two functions. The first function is oscillator switching frequency adjustment. Connecting a resistor ( $R_T$ ) from this pin to GND increases the frequency according to the following equation:

$$F_s \cong 200\text{KHz} + \frac{5 \times 10^5}{\log R_T}$$

The second function for this pin is to drive an external SCR in the event of an over voltage fault.

**PIN 16: VSEN** - Converter output voltage sense pin. Connect this pin to the converter output. The PGOOD and OVP comparator circuits use this signal to report output voltage status and perform overvoltage protection function.

■ **PHYSICAL DIMENSION**

- 16 LEAD PLASTIC SO (150 mil) (unit: mm)

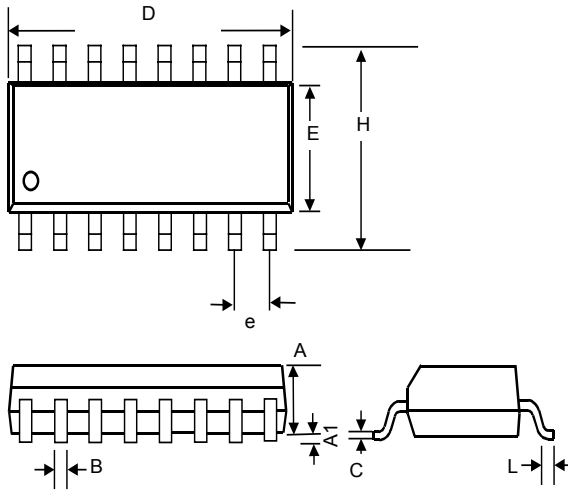

SYMBOL	MIN	MAX
A	1.35	1.75
A1	0.10	0.25
B	0.33	0.51
C	0.19	0.25
D	9.80	10.00
E	3.80	4.00
e	1.27 (TYP)	
H	5.80	6.20
L	0.40	1.27