

1.4MHz Current-Mode Step-Up DC/DC Converter

FEATURES

- Fixed Frequency 1.4MHz Current-Mode PWM Operation.
- Adjustable Output Voltage up to 30V.
- Guaranteed 12V/ 150mA Output with 5V Input.
- 2.6V to 10V Input Range.
- Maximum 0.1 μ A Shutdown Current.
- Programmable Soft-Start.
- Tiny Inductor and Capacitors are allowed.
- Space-Saving SOT-23-6 Package.

APPLICATIONS

- LCD Bias
- LCM
- OLED Driver

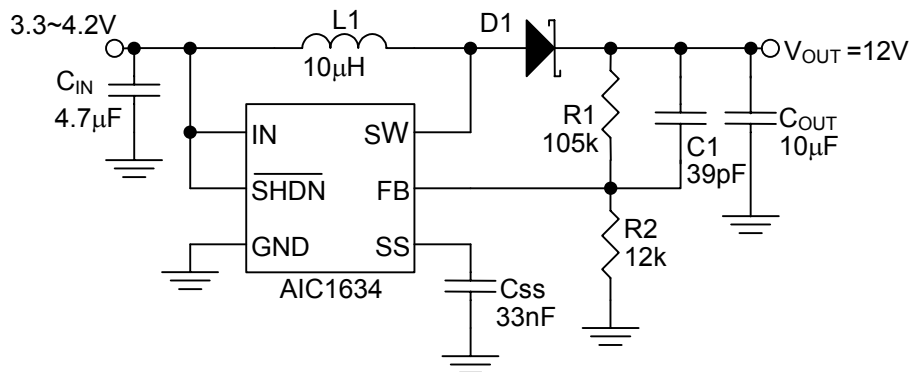
DESCRIPTION

AIC1634 is a current-mode pulse-width modulation (PWM), step-up DC/DC Converter. The built-in high voltage N-channel MOSFET allows AIC1634 for step-up applications with up to 30V output voltage, as well as for Single Ended Primary Inductance Converter (SEPIC) and other low-side switching DC/DC converter.

The high switching frequency (1.4MHz) allows the use of small external components. The Soft-Start function is programmable with an external capacitor, which sets the input current ramp rate.

The AIC1634 is available in a space-saving SOT-23-6 package.

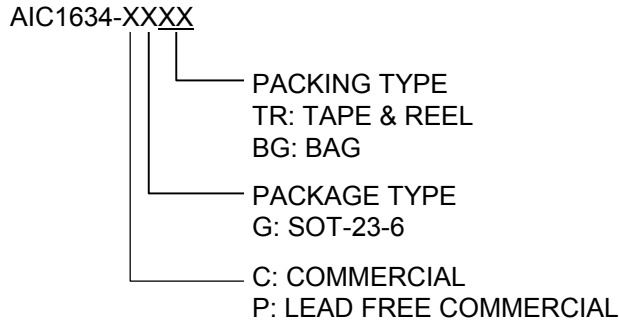
TYPICAL APPLICATION CIRCUIT

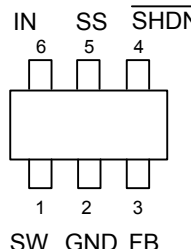


L1: SLF6025-100M1R0, TDK
 D1: SS0540, PAN JIT
 C_{IN}: EDK316BJ475KD, Taiyo Yuden
 C_{OUT}: TMK316C106KL, Taiyo Yuden

Fig. 1 12V LCD Bias Application for Li-Ion Battery

ORDERING INFORMATION



ORDER NUMBER	PIN CONFIGURATION
AIC1634CG&PG (SOT-23-6)	FRONT VIEW 

- Example: AIC1634-CGTR
 → in SOT-23-6 Package & Tape & Reel Packing Type
- AIC1634-PGTR
 → in Lead Free SOT-23-6 Package & Tape & Reel Packing Type

SOT-23-6 Marking

Part No.	Marking
AIC1634CG	1634
AIC1634PG	1634P

ABSOLUTE MAXIMUM RATINGS

SW to GND	33V
FB to GND	6V
IN, $\overline{\text{SHDN}}$	11V
SS to GND	6V
SW Pin RMS Current	0.6A
Operating Temperature Range	-40°C to 85°C
Junction Temperature	125°C
Storage Temperature Range	-65°C to 150°C
Lead Temperature (soldering, 10 sec.)	260°C

Absolute Maximum Ratings are those values beyond which the life of a device may be impaired.

TEST CIRCUIT

Refer to "TYPICAL APPLICATION CIRCUIT".

■ ELECTRICAL CHARACTERISTICS

($V_{IN} = \overline{V_{SHDN}} = 3V$, SS=Open, $T_A = 25^\circ C$, unless otherwise specified) (Note 1)

PARAMETER	SYMBOL	CONDITIONS	MIN	TYP	MAX	UNITS
Input Supply Range	V_{IN}		2.6		10	V
Output Voltage Adjust Range	V_{OUT}				30	V
V_{IN} Undervoltage Lockout	UVLO	V_{IN} rising, 50mV hysteresis		2.2		V
Quiescent Current	I_{IN}	$V_{FB} = 1.3V$, not switching		0.1	0.2	mA
		$V_{FB} = 1.0V$, switching		1	5	
Shutdown Supply Current		$\overline{V_{SHDN}} = 0V$		0.01	0.5	μA
ERROR AMPLIFIER						
Feedback Voltage	V_{FB}		1.205	1.23	1.255	V
FB Input Bias Current	I_{FB}	$V_{FB} = 1.24V$		21	80	nA
Feedback-Voltage Line Regulation		$2.6V < V_{IN} < 5.5V$		0.05	0.50	%/V
OSCILLATOR						
Frequency	f_{OSC}		1	1.4	1.8	MHz
Maximum Duty Cycle	DC		85	90		%
POWER SWITCH						
On-Resistance	$R_{DS(ON)}$	$V_{IN} = 5V$		1	1.4	Ω
Leakage Current	$I_{LX(OFF)}$	$V_{LX} = 30V$		0.1	1	μA
Switch Current Limit	I_{IL}		400	500	650	mA
SOFT-START						
Reset Switch Resistance		Guaranteed By Design			100	Ω
Charge Current		$V_{SS} = 1.2V$	1.5	4	7.0	μA
CONTROL INPUT						
Input Low Voltage	V_{IL}	$\overline{V_{SHDN}}$, $V_{IN} = 2.5V$ to $10V$			0.3	V
Input High Voltage	V_{IH}	$\overline{V_{SHDN}}$, $V_{IN} = 2.5V$ to $10V$	1.0			V
\overline{SHDN} Input Current	$I_{\overline{SHDN}}$	$\overline{V_{SHDN}} = 3V$		25	50	μA
		$\overline{V_{SHDN}} = 0V$		0.01	0.1	

Note 1: Specifications are production tested at $T_A = 25^\circ C$. Specifications over the $-40^\circ C$ to $85^\circ C$ operating temperature range are assured by design, characterization and correlation with Statistical Quality Controls (SQC).

■ TYPICAL PERFORMANCE CHARACTERISTICS

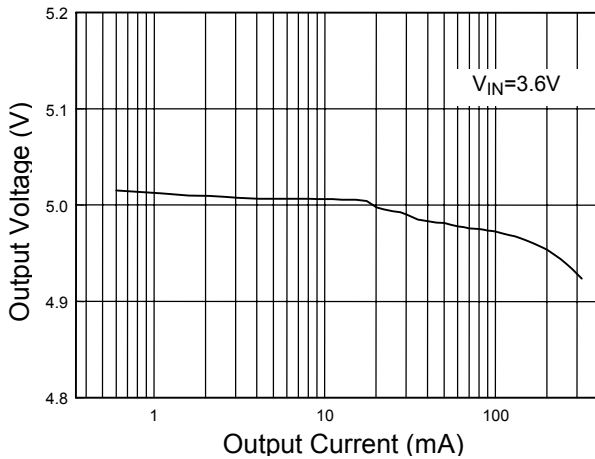


Fig. 2 Load Regulation

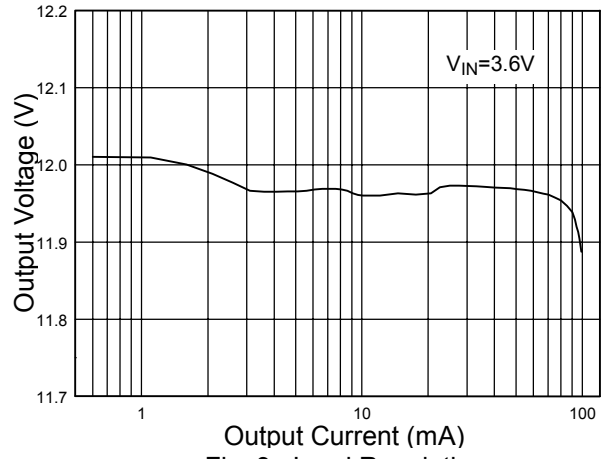


Fig. 3 Load Regulation

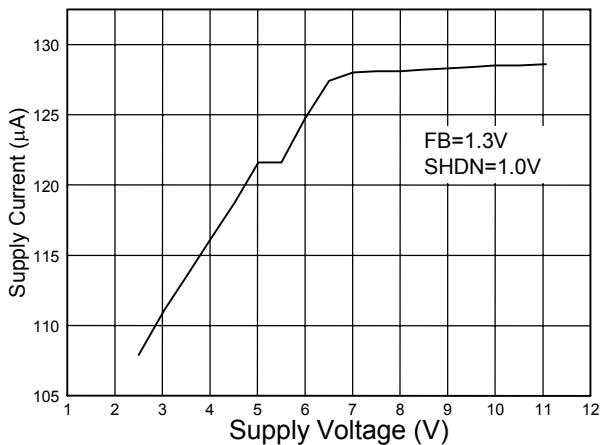


Fig. 4 Non-Switching Current

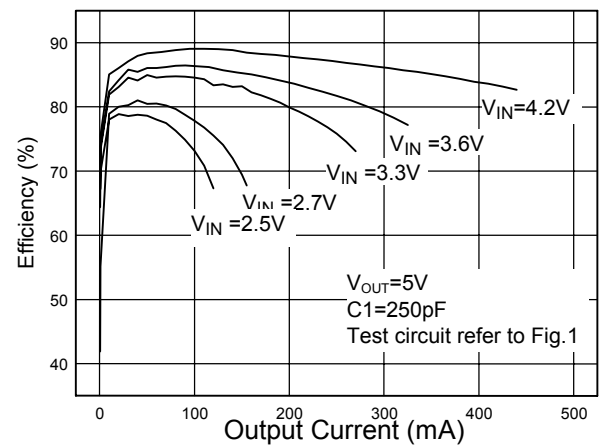


Fig. 5 Efficiency vs. Output Current

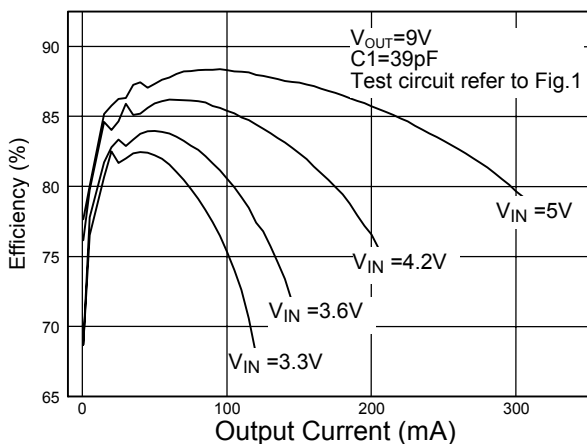


Fig. 6 Efficiency vs. Output Current

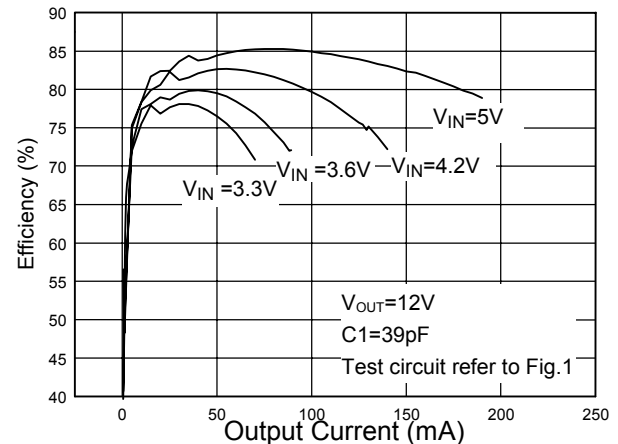


Fig. 7 Efficiency vs. Output Current

■ TYPICAL PERFORMANCE CHARACTERISTICS (Continued)

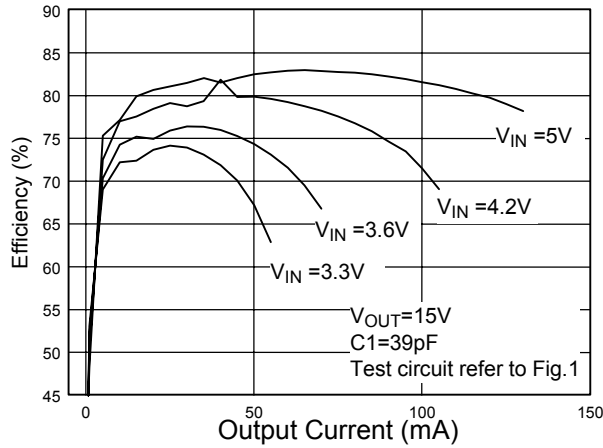


Fig. 8 Efficiency vs. Output Current

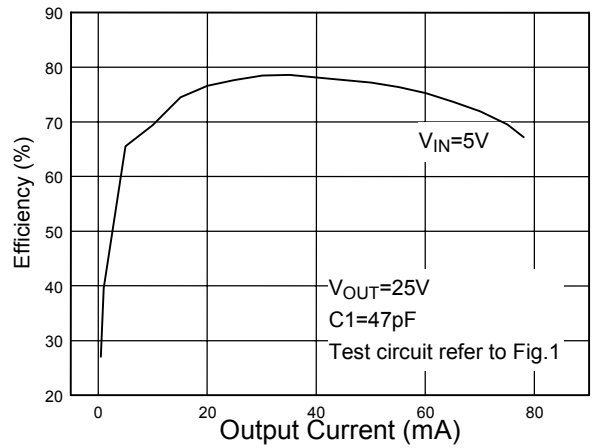


Fig. 9 Efficiency vs. Output Current

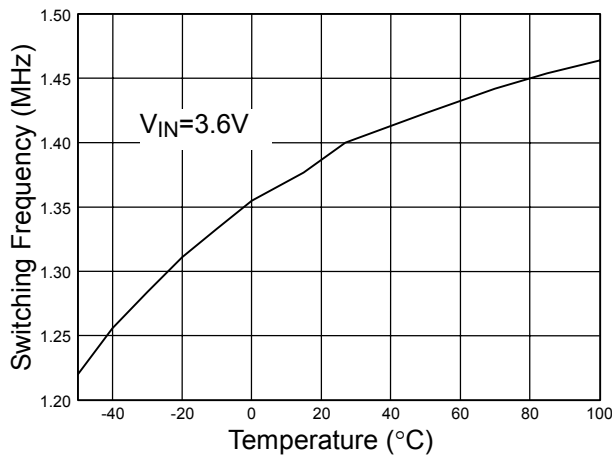


Fig. 10 Switching Frequency vs. Temperature

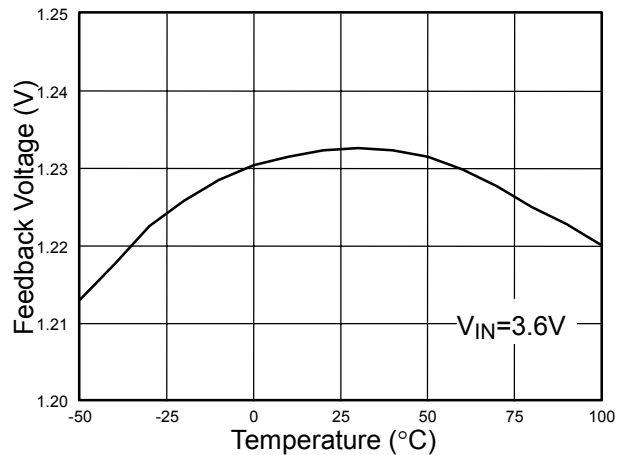


Fig. 11 Feedback Pin Voltage

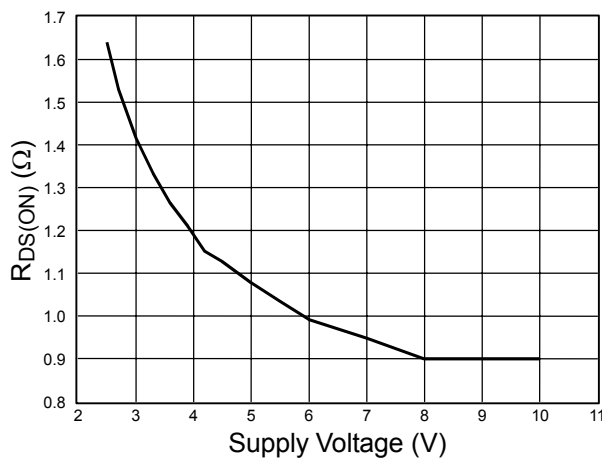


Fig. 12 R_{DS-ON} vs. Supply Voltage

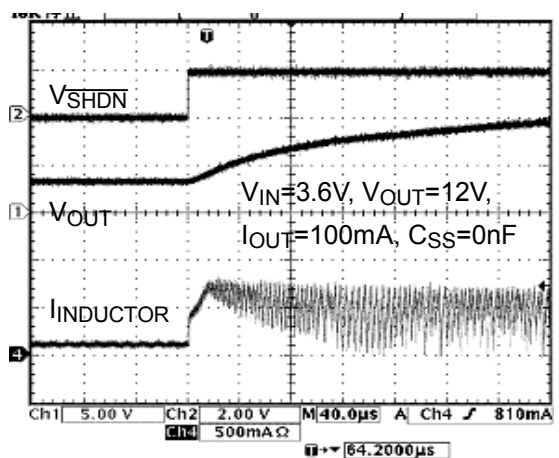


Fig. 13 Start-Up from Shutdown

■ TYPICAL PERFORMANCE CHARACTERISTICS (Continued)

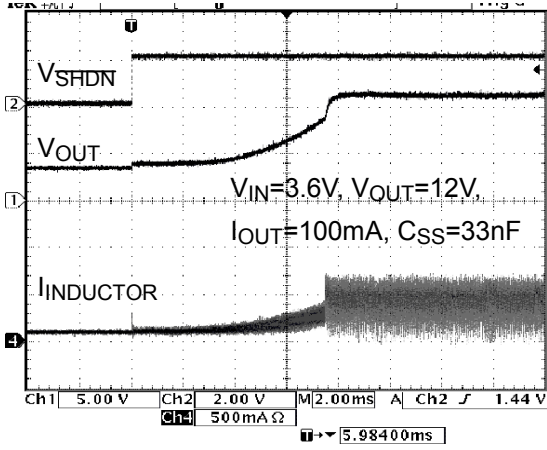


Fig. 14 Start-Up from Shutdown

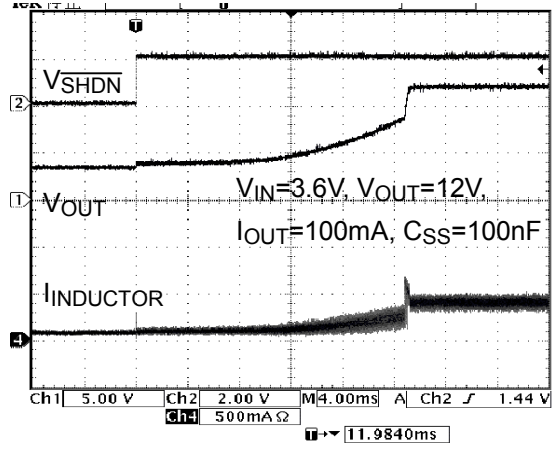


Fig. 15 Start-Up from Shutdown

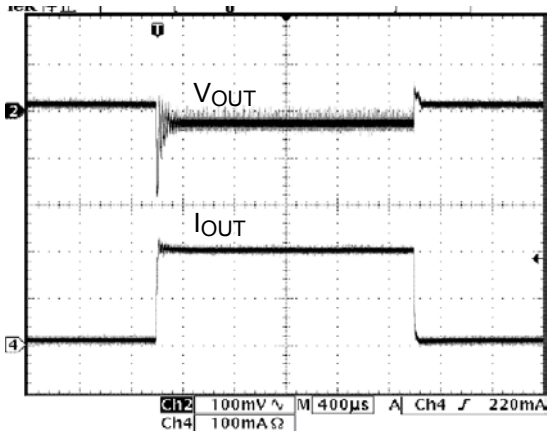


Fig. 16 Load Step Response
 $V_{IN}=3.3V$, $V_{OUT}=5V$, $I_{LOAD}=5mA$ to $200mA$

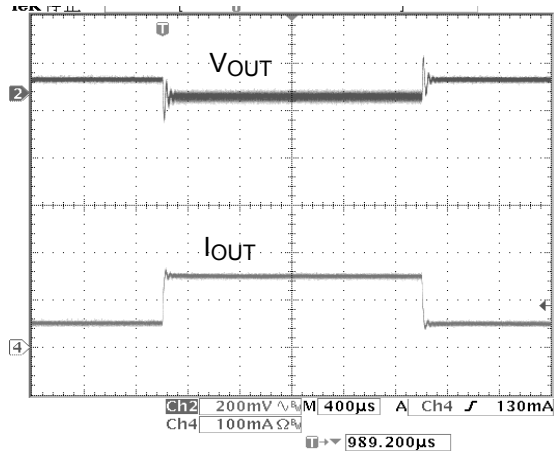
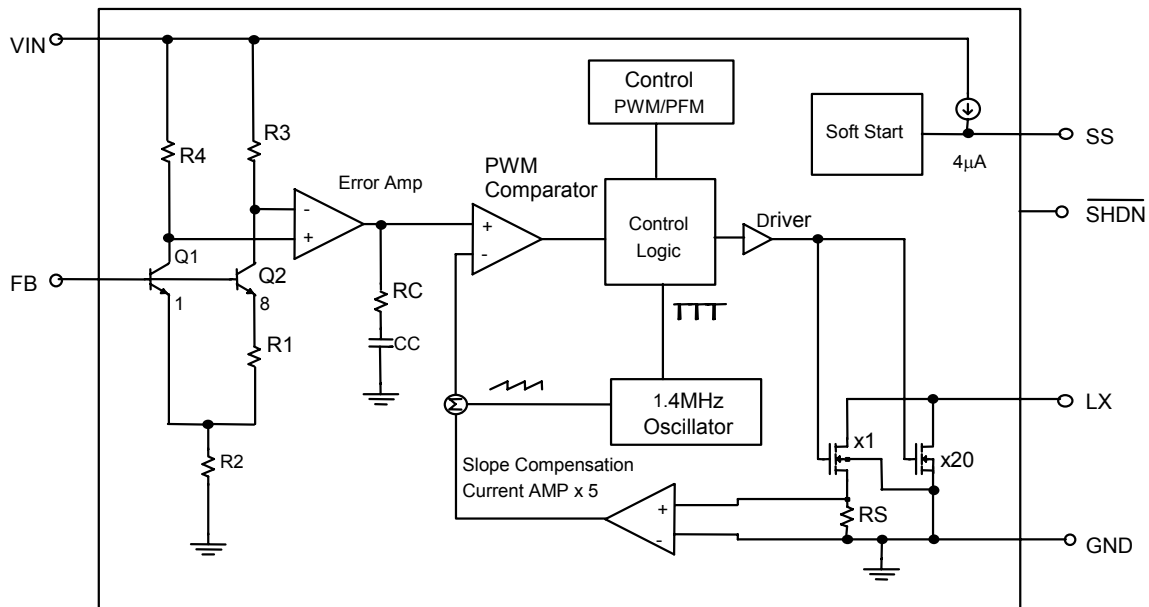


Fig. 17 Load Step Response
 $V_{IN}=5V$, $V_{OUT}=12V$, $I_{LOAD}=50mA$ to $150mA$

■ BLOCK DIAGRAM



■ PIN DESCRIPTIONS

PIN 1: SW - Power Switching Connection. Connect SW to inductor and output rectifier. Keep the distance between the components as close to SW as possible.

PIN 2: GND - Ground.

PIN 3: FB - Feedback Input. Connect a resistive voltage divider from the output to FB to set the output voltage.

$$V_{OUT} = 1.23V \left(\frac{R_1}{R_2} + 1 \right)$$

PIN 4: $\overline{\text{SHDN}}$ - Shutdown Input. Drive $\overline{\text{SHDN}}$ low to turn off the converter. To

automatically start the converter, connect $\overline{\text{SHDN}}$ to IN. Do not leave $\overline{\text{SHDN}}$ unconnected. $\overline{\text{SHDN}}$ draws up to 50 μ A.

PIN 5: SS - Soft-Start Input. Connect a soft-start capacitor from SS to GND in order to soft-start the converter. Leave SS open to disable the soft-start function.

PIN 6: IN - Internal Bias Voltage Input. Connect IN to the input voltage source. Bypass IN to GND with a capacitor sitting as close to IN as possible.

■ APPLICATION INFORMATION

Inductor Selection

A 10 μ H inductor is recommended for most AIC1634 applications. Although small size and high efficiency are major concerns, the inductor should have low core losses at 1.4MHz and low DCR (copper wire resistance) to decrease power loss.

Capacitor Selection

The small size of ceramic capacitors makes them ideal for AIC1634 applications. X5R and X7R types are recommended because they retain their capacitance over wider ranges of voltage and temperature than other types, such as Y5V or Z5U. Low ESR capacitors for the output to minimize output voltage ripple. A 4.7 μ F input capacitor and a 10 μ F output capacitor are sufficient for most light load applications, yet, a

10 μ F input capacitor and a 10 μ F output capacitor for heavy load.

Diode Selection

Schottky diodes, with their low forward voltage drop and fast reverse recovery, are the ideal choices for AIC1634 applications. The forward voltage drop of the Schottky diode represents the conduction losses in the diode, while the diode capacitance (CT or CD) represents the switching losses. For diode selection, both forward voltage drop and diode capacitance need to be considered. Schottky diodes with higher current ratings usually have lower forward voltage drop and larger diode capacitance, which can cause significant switching losses at the 1.4MHz switching frequency of AIC1634.

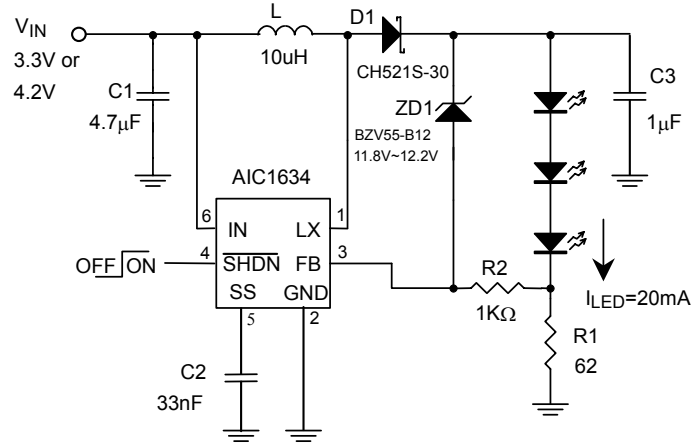
APPLICATION EXAMPLES


Fig. 18 1-Cell Li-Ion Powered Driver for three White LEDs with Open-Circuit Protection

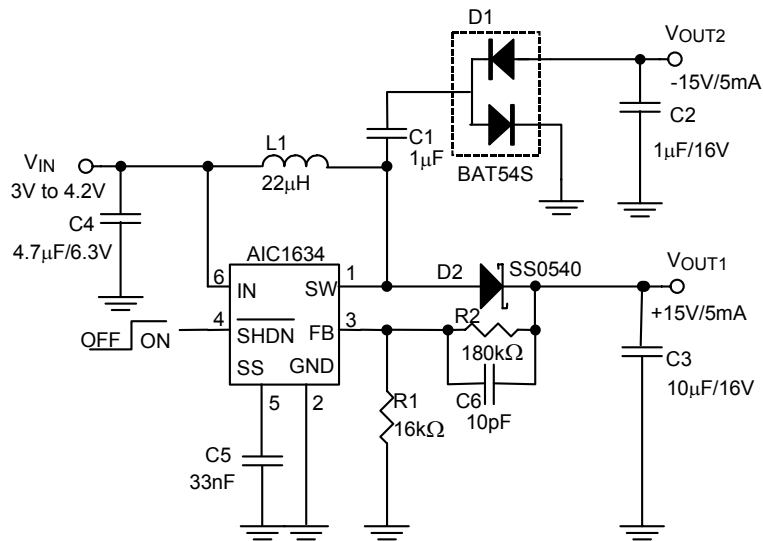
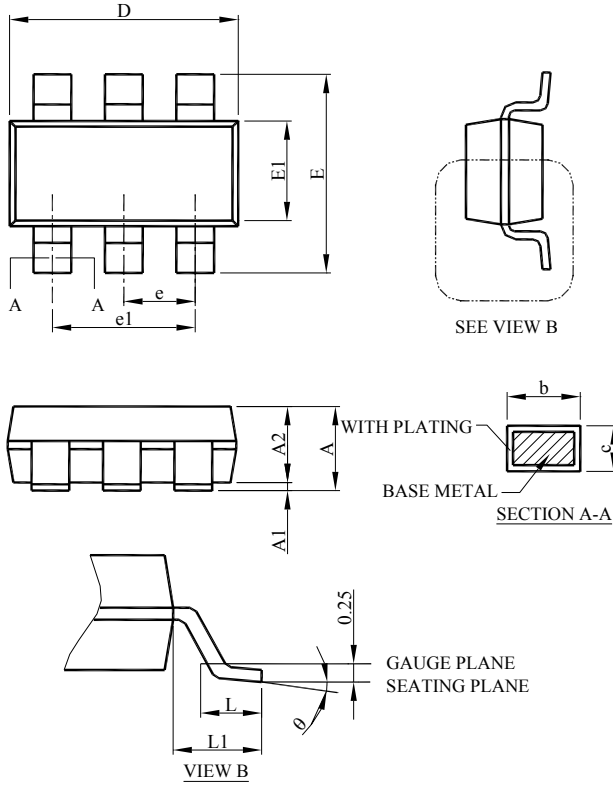


Fig. 19 1-Cell Li-Ion to $\pm 15V/5mA$ Dual Output Converter for LCD Bias

■ PHYSICAL DIMENSIONS (unit: mm)

● SOT-23-6



SYMBOL	SOT-26	
	MILLIMETERS	
	MIN.	MAX.
A	0.95	1.45
A1	0.05	0.15
A2	0.90	1.30
b	0.30	0.50
c	0.08	0.22
D	2.80	3.00
E	2.60	3.00
E1	1.50	1.70
e	0.95 BSC	
e1	1.90 BSC	
L	0.30	0.60
L1	0.60 REF	
θ	0°	8°

Note:

Information provided by AIC is believed to be accurate and reliable. However, we cannot assume responsibility for use of any circuitry other than circuitry entirely embodied in an AIC product; nor for any infringement of patents or other rights of third parties that may result from its use. We reserve the right to change the circuitry and specifications without notice.

Life Support Policy: AIC does not authorize any AIC product for use in life support devices and/or systems. Life support devices or systems are devices or systems which, (i) are intended for surgical implant into the body or (ii) support or sustain life, and whose failure to perform, when properly used in accordance with instructions for use provided in the labeling, can be reasonably expected to result in a significant injury to the user.