

1.2MHz, Synchronous Step-Up Converter in SOT23-6

FEATURES

- Output Voltage Range: 2.5V to 4.0V
- Synchronous 92% Efficient Boost Converter
- 1.2 MHz Fixed Switching Frequency
- Built-in current mode compensation
- Built-in Protection: Over Current Protection and Over Temperature Protection.
- Quiescent Current: 300 μ A at $V_{IN}=1.1V$, $V_{OUT}=3.3V$, $I_{OUT}=0A$
- <1 μ A Shutdown Standby Current
- EMI Reduction Anti-Ringing Control Circuitry
- Thin SOT23-6 package

APPLICATIONS

- Single / Dual Cells Ni-Cd / Ni-Mh Type Battery Operated Products
- Internet Audio Player
- Wireless and DSL Modems
- Digital Still Cameras
- Portable Equipment

DESCRIPTION

The AIC3414 step-up converter is based on a fixed frequency, pulse-width-modulation (PWM) controller using an internal synchronous rectifier to obtain maximum efficiency. It stays in operation with supply voltages down to 0.5V. The AIC3414 provides a complete power supply solution for products powered by either one or two Alkaline, Ni-Cd, or Ni-MH battery cells. The AIC3414 output voltage can be adjustable up to 4.0V. At light load condition, the AIC3414 can work at PSM mode to improve efficiency and reduce quiescent current.

The AIC3414 includes the anti-ringing circuitry. The anti-ringing circuitry is implemented to reduce ringing and in effect lower radiated electromagnetic energy when the converter enters the discontinuous conduction mode.

TYPICAL APPLICATION CIRCUITS

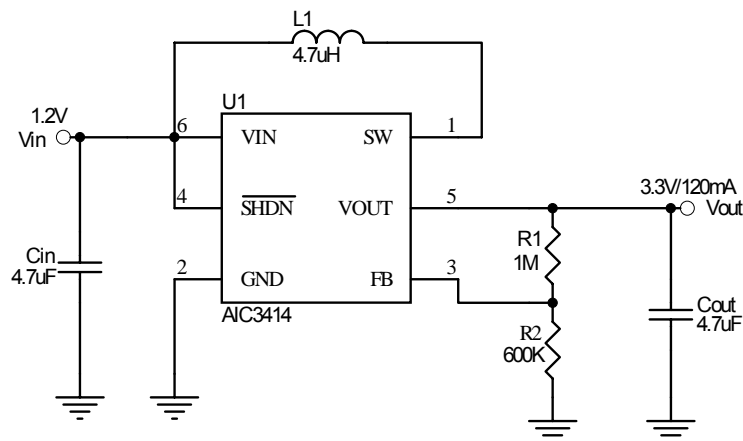

www.DataSheet4U.com

■ **ORDERING INFORMATION**

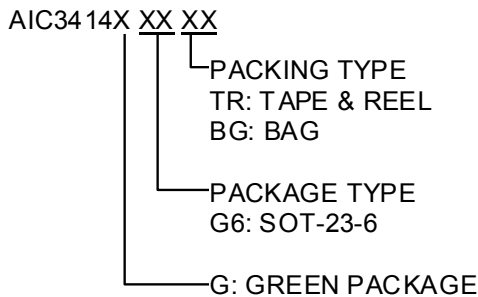

Example: AIC3414GG6TR
 → in SOT-23-6 Green Package & Taping & Reel Packing Type

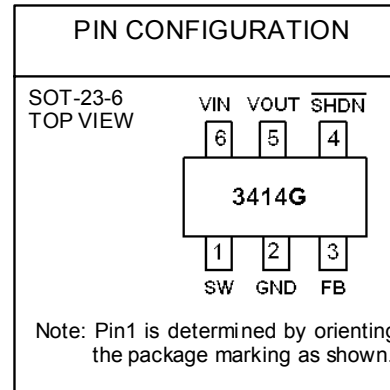

● **Marking**

Part No.	Marking
AIC3414GG6	3414G

■ **ABSOLUTE MAXIMUM RATINGS**

Input Voltage	6V
SHDN Pin Voltage	6V
SW and FB Pin Voltage	6V
Operating Temperature Range	-40°C to 85°C
Maximum Junction Temperature	150°C
Storage Temperature Range	-65°C to 150°C
Lead Temperature (Soldering 10 Sec.)	260°C
Thermal Resistance (Junction to Case)	115°C/W
Thermal Resistance (Junction to Ambient)	250°C/W

(Assume no Ambient Airflow, no Heatsink)

Absolute Maximum Ratings are those values beyond which the life of a device may be impaired.

■ ELECTRICAL CHARACTERISTICS

($T_A=25^\circ\text{C}$, $V_{in}=1.2\text{V}$, $V_{out}=3.3\text{V}$, unless otherwise specified.) (Note1)

PARAMETER	TEST CONDITION	SYMBOL	MIN	TYP	MAX	UNIT
Output Voltage Range		V_{OUT}	2.5		4.0	V
Minimum Start Up Voltage	$I_{OUT}=1\text{mA}$			0.9	1.1	V
Minimum Operation Voltage	$\overline{\text{SHDN}}=V_{IN}$			0.5		V
Quiescent Current	$V_{FB}=1.4\text{V}$	I_Q		300	500	μA
Shut Down Current (Oscillator no switching)	$\overline{\text{SHDN}}=0\text{V}$, $V_{IN}=1.1\text{V}$, $V_{OUT}=3.3\text{V}$	I_{SD}		0.1	1	μA
Line Regulation	$V_{IN}=1.5\sim 2.5\text{V}$, $V_{OUT}=3.3\text{V}$, $I_{OUT}=1\text{mA}$			10		mV/V
Load Regulation	$V_{IN}=2.5\text{V}$, $V_{OUT}=3.3\text{V}$, $I_{OUT}=1\sim 100\text{mA}$			0.25		mV/ mA
Feedback Voltage		V_{FB}	1.192	1.23	1.268	V
FB Input Leakage Current	$V_{FB}=1.25\text{V}$	I_{FB}			0.1	μA
Maximum Duty Cycle (PWM)	Measurement on the LX	DUTY	80	88		%
Oscillator Frequency (PWM)		F	950	1200	1500	kHz
NMOS Switch Leakage	$V_{LX}=3.6\text{V}$			0.1	5	μA
NMOS Switch On Resistance	$V_{OUT}=3.3\text{V}$			0.35		Ω
PMOS Switch On Resistance	$V_{OUT}=3.3\text{V}$			0.45		Ω
$\overline{\text{SHDN}}$ High Threshold Voltage		$V_{\overline{\text{SHDN}},H}$	0.8			V
$\overline{\text{SHDN}}$ Low Threshold Voltage		$V_{\overline{\text{SHDN}},L}$			0.35	V
$\overline{\text{SHDN}}$ Input Current	$\overline{\text{SHDN}}=5.5\text{V}$	$I_{\overline{\text{SHDN}}}$		0.01	2	μA
Current Limit Setting	$V_{OUT}=3.3\text{V}$, Measure N-MOS current	I_{OCP}		0.85		A
Over temperature Protection				140		$^\circ\text{C}$
Over temperature Hysteresis				10		$^\circ\text{C}$

Note 1: Specifications are production tested at $T_A=25^\circ\text{C}$. Specifications over the -40°C to 85°C operating temperature range are assured by design, characterization and correlation with Statistical Quality Controls (SQC).

TYPICAL PERFORMANCE CHARACTERISTICS

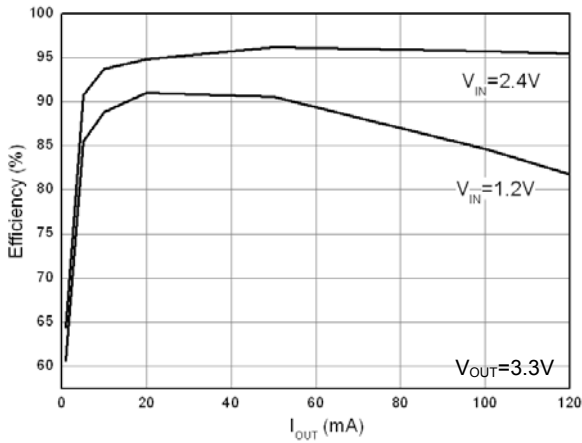

Fig. 1 Efficiency vs. Output Current

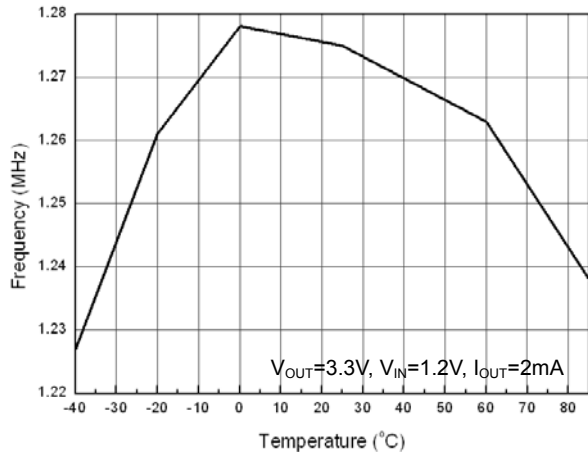

Fig. 2 Frequency vs. Temperature

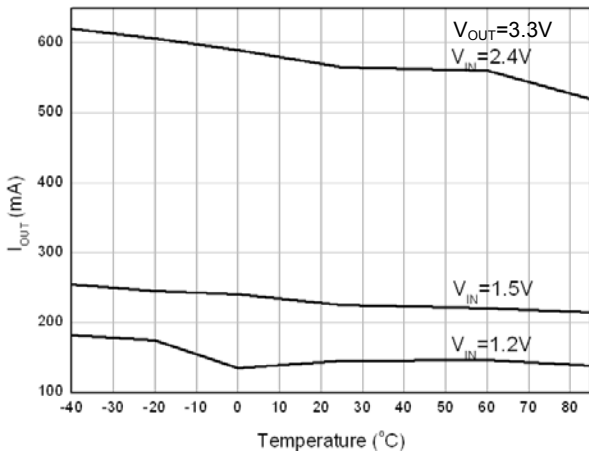

Fig. 3 Maximum Output Current vs. Temperature

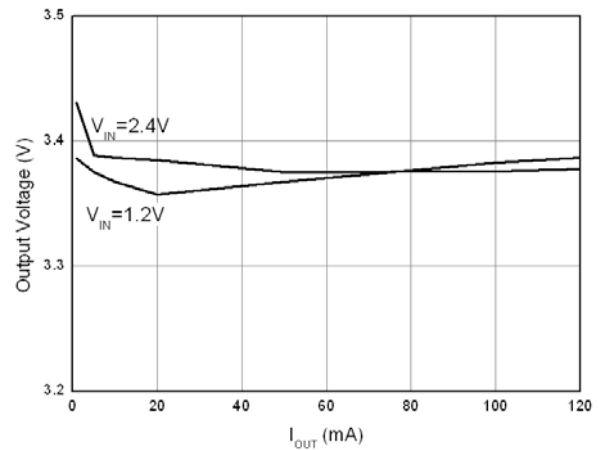

Fig. 4 Output Voltage vs. Output Current

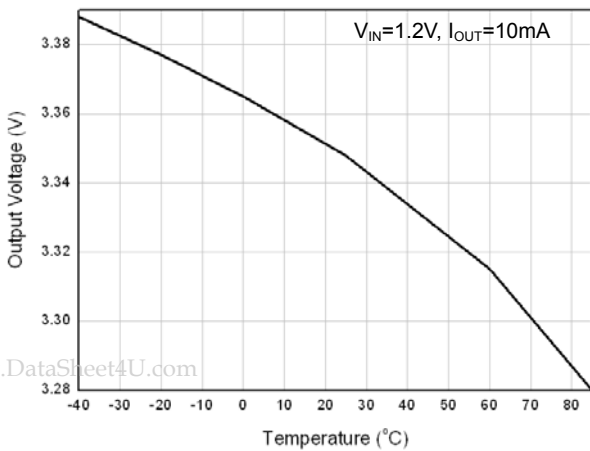

Fig. 5 Output Voltage vs. Temperature

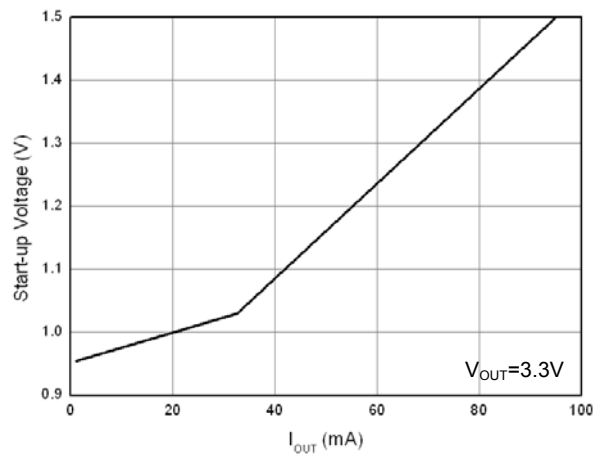

Fig. 6 Minimum Start-up Voltage vs. Output current

TYPICAL PERFORMANCE CHARACTERISTICS (Continued)

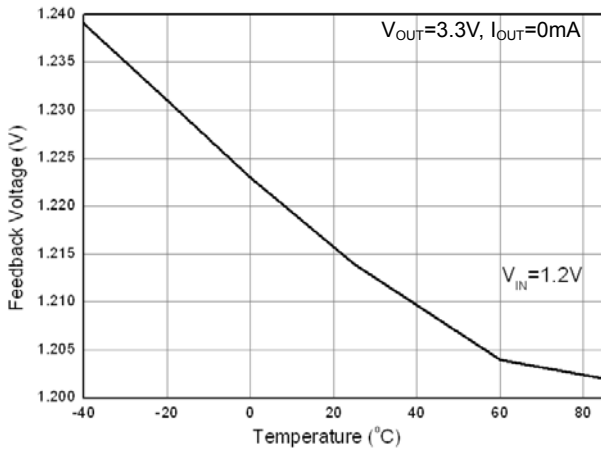

Fig. 7 Feedback Voltage vs. Temperature

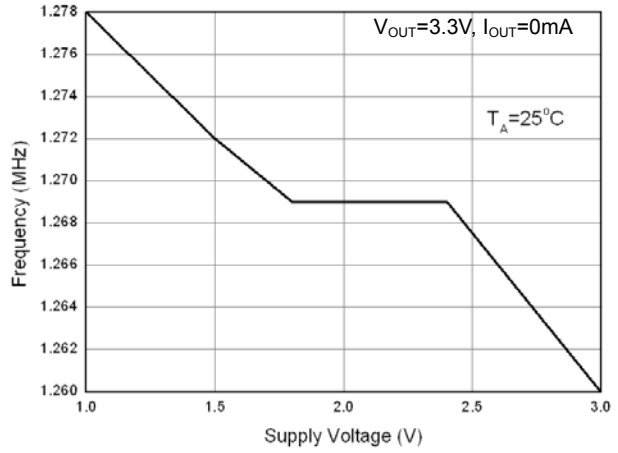

Fig. 8 Frequency vs. Supply Voltage

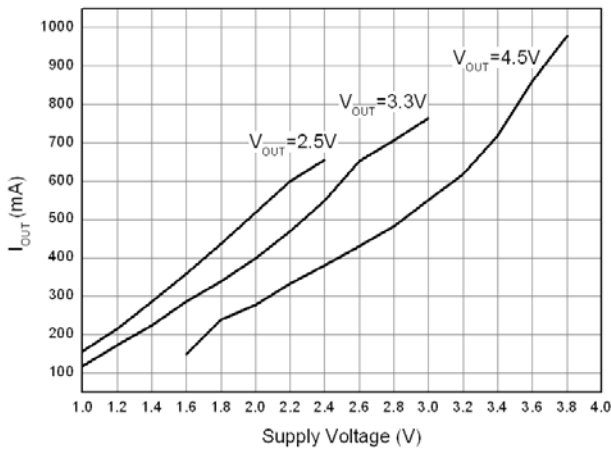

Fig. 9 Maximum Output Current vs. Supply Voltage

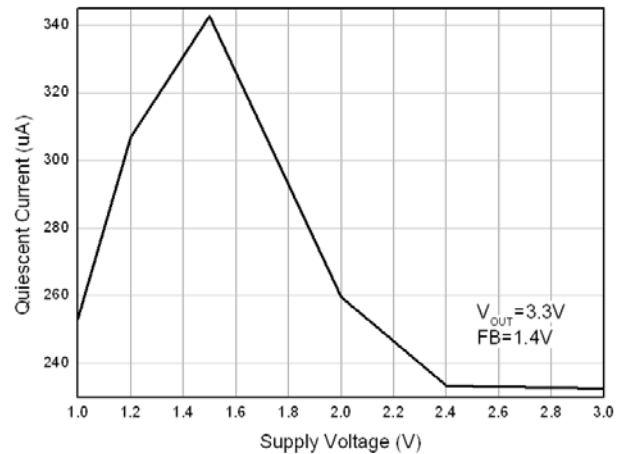

Fig. 10 Quiescent Current vs. Supply Voltage

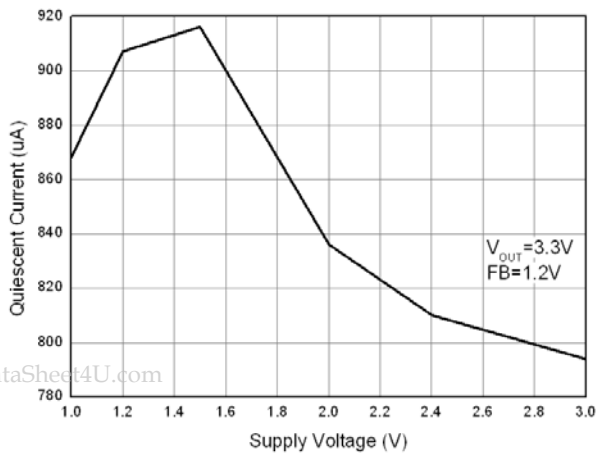

Fig. 11 Quiescent Current vs. Supply Voltage

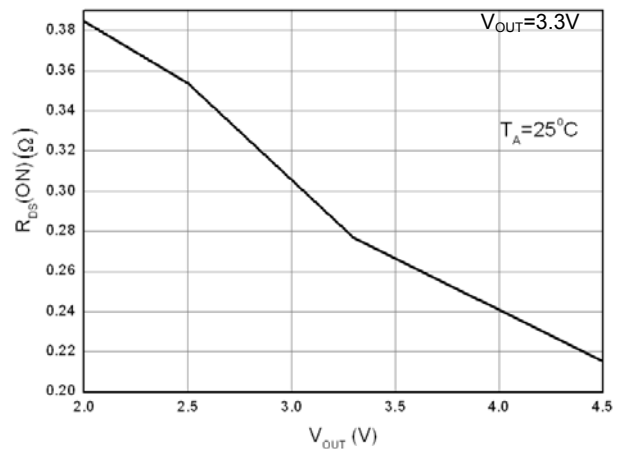

Fig. 12 NMOS R_{DS} (ON) vs. Supply Voltage

TYPICAL PERFORMANCE CHARACTERISTICS (Continued)

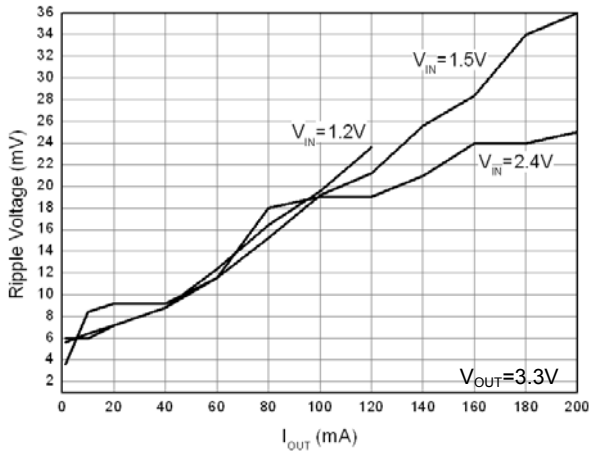

Fig. 13 Ripple Voltage vs. Output Current

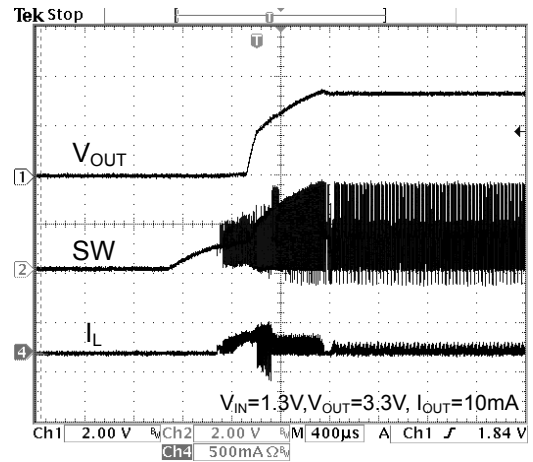

Fig. 14 Start-up Voltage Waveform

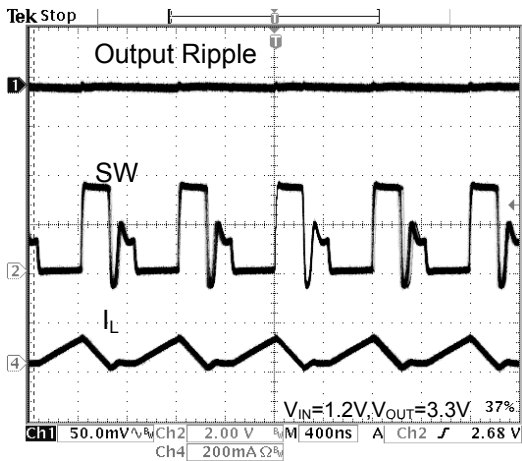

Fig. 15 Anti-Ringing Operation ($I_{OUT} = 10mA$)

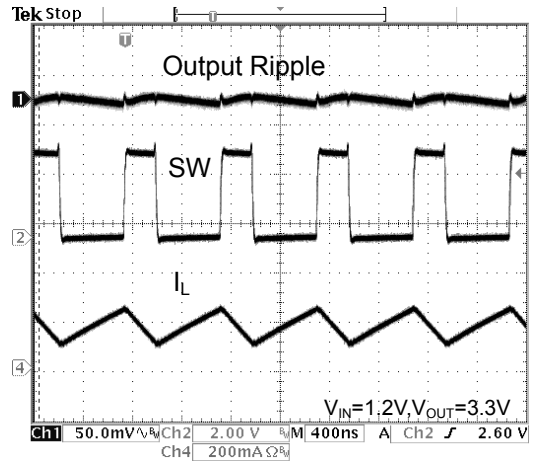

Fig. 16 CCM Switch Waveform ($I_{OUT} = 50mA$)

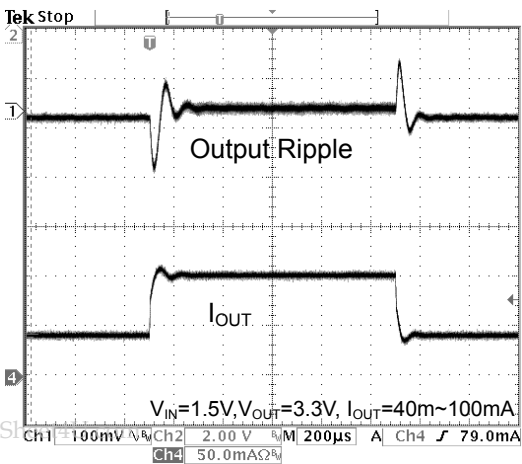
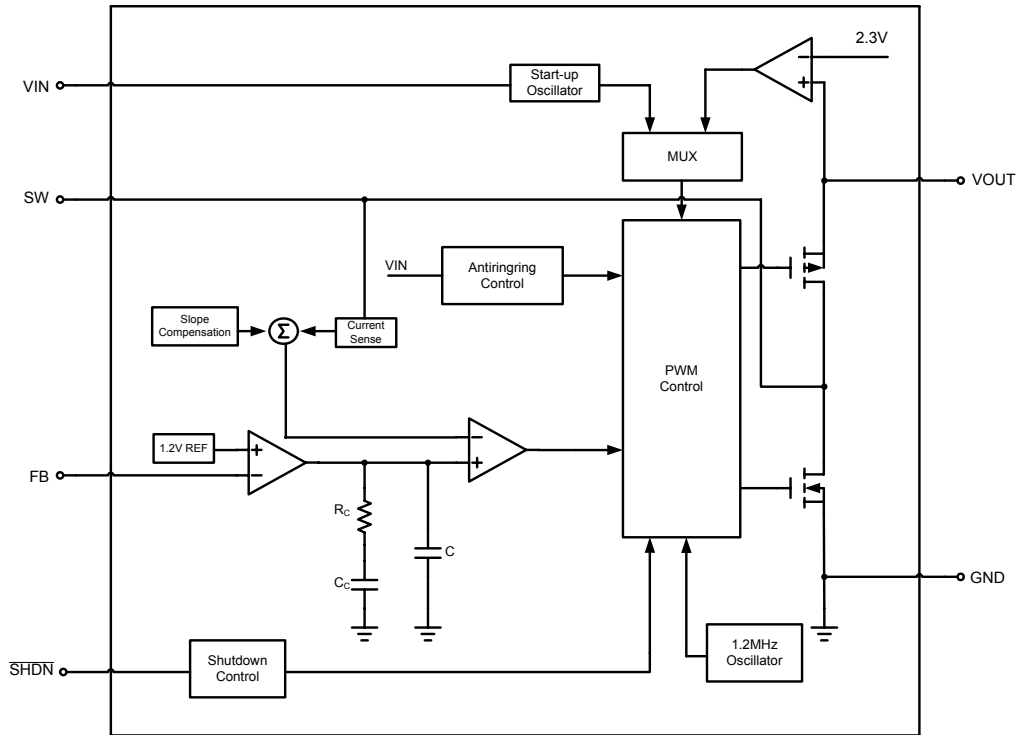

Fig. 17 Load Transient Response

■ BLOCK DIAGRAM



■ PIN DESCRIPTIONS

PIN 1: SW - Power Switch Pin. Connect inductor between SW and VIN

PIN 2: GND - I/O Control/logic ground.

PIN 3: FB - Boost-Voltage feedback of adjustable version, the feedback reference Voltage is typically 1.23V

PIN 4: $\overline{\text{SHDN}}$ - Shutdown Signal Input. Logic high enables the IC. Logic low disables the IC. Shutdown current is $<1\mu\text{A}$.

PIN 5: VOUT- Power Output Pin. Connected to the positive terminal of the output capacitor and to the external resistor divider.

PIN 6: VIN - Power Supply Input. Must be closely decoupled to GND, Pin 2, with a $4.7\mu\text{F}$ or greater ceramic capacitor.

■ APPLICATION INFORMATION

The AIC3414 is a synchronous step-up DC-DC converter. It is based on a slope compensated current mode PWM control topology. It operates at a fixed frequency of 1.2MHz. At the beginning of each clock cycle, the main switch (NMOS) is turned on and the inductor current starts to ramp. After the maximum duty cycle or the sense current signal equals the error amplifier (EA) output, the main switch is turned off and the synchronous switch (PMOS) is turned on. The device can operate with an input voltage below 1V; the typical start-up voltage is 0.9V.

Current Limit

The over current protection is to limit the switch current. The output Voltage will be dropped when over current is happened. The current limit amplifier will shut the N-MOS switch off once the current exceeds its threshold. The current amplifier delay to output is about 50 nS.

Anti-Ringing Control

An anti-ringing circuitry is included to remove the high frequency ringing that appears on the SW pin when the inductor current goes to zero. In this case, a ringing on the SW pin is induced due to remaining energy stored in parasitic components of switch and inductor. The anti-ringing circuitry clamps the voltage internally to the battery voltage and therefore dampens this ringing.

Zero Current Comparator

The zero current comparator monitors the inductor current to the output and shuts off the synchronous rectifier once the current is below 20 mA, This prevents the inductor current from reversing in polarity improving efficiency at light loads.

Device Shutdown

When $\overline{\text{SHDN}}$ is set logic high, the AIC3414 is put into active mode operation. If $\overline{\text{SHDN}}$ is set logic low, the device is put into shutdown mode and consumes less than 1µA of current. After start-up, the internal circuitry is supplied by V_{OUT} , however, if shutdown mode is enabled, the internal circuitry will be supplied by the input source again.

Adjustable Output Voltage

An external resistor divider is used to set the output voltage. The output voltage of the switching regulator (V_{OUT}) is determined by the following equation:

$$V_{\text{OUT}} = V_{\text{FB}} \times \left(1 + \frac{R_1}{R_2} \right)$$

Where V_{FB} is 1.23V reference voltage.

Input Inductor Selection

The inductor value determines the ripple current. The approximate ripple current and inductance value are measured by the following equations:

$$\Delta I_L = \frac{V_{\text{IN}} D}{L f_{\text{SW}}}$$

Where ΔI_L = inductor ripple current

f_{SW} = switch frequency

D = duty cycle, $(V_{\text{OUT}} - V_{\text{IN}}) / V_{\text{OUT}}$

Increasing the value of inductance will reduce the output ripple current and ripple voltage.

Input Capacitor Selection

Surfaces mount 4.7µF or greater, X5R or X7R, ceramic capacitor is suggested for the input capacitor. The input capacitor provides a low impedance loop for the edges of pulsed current drawn by the AIC3414. Low

ESR/ESL X7R and X5R ceramic capacitors are ideal for this function. To minimize stray inductance, the capacitor should be placed as close as possible to the IC.

This keeps the high frequency content of the input current localized, minimizing EMI and input voltage ripple. Always examine the ceramic capacitor DC voltage coefficient characteristics to get the proper value.

Output Capacitor Selection

The output capacitor limits the output ripple and provides holdup during large load transitions. A 4.7µF to 10µF, X5R or X7R, ceramic capacitor is suggested for the output capacitor. Typically the recommended capacitor range provides sufficient bulk capacitance to stabilize the output voltage during large load transitions

and has the low ESR and ESL characteristics necessary for low output voltage ripple.

PCB Layout Guidance

The AIC3414 typically operates at 1.2MHz. This is a considerably high frequency for DC-DC converters. PCB layout is important to guarantee satisfactory performance. It is recommended to make traces of the power loop, especially where the switching node is involved, as short and wide as possible. First of all, the inductor, input and output capacitor should be as close as possible to the device. Feedback and shutdown circuits should avoid the proximity of large AC signals involving the power inductor and switching node.

APPLICATION CIRCUITS

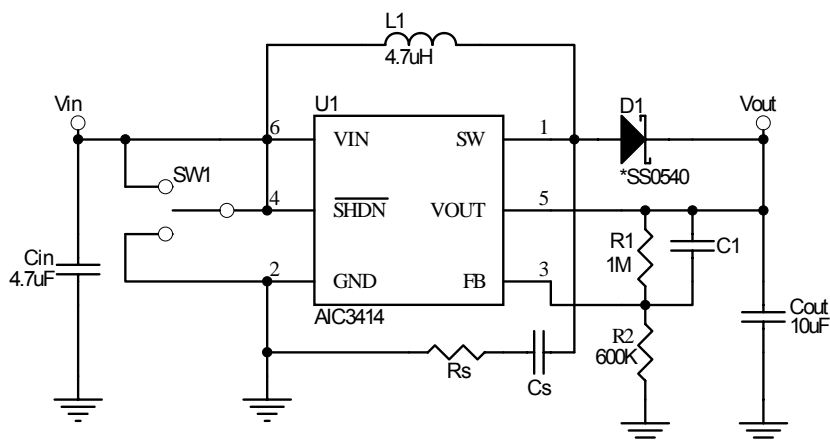

*Note: Efficiency can boost if D1 is connected.

R_s and C_s will reduce spike of circuit

Fig.11 AIC3414 Application Circuit.

■ PHYSICAL DIMENSIONS

● SOT-26

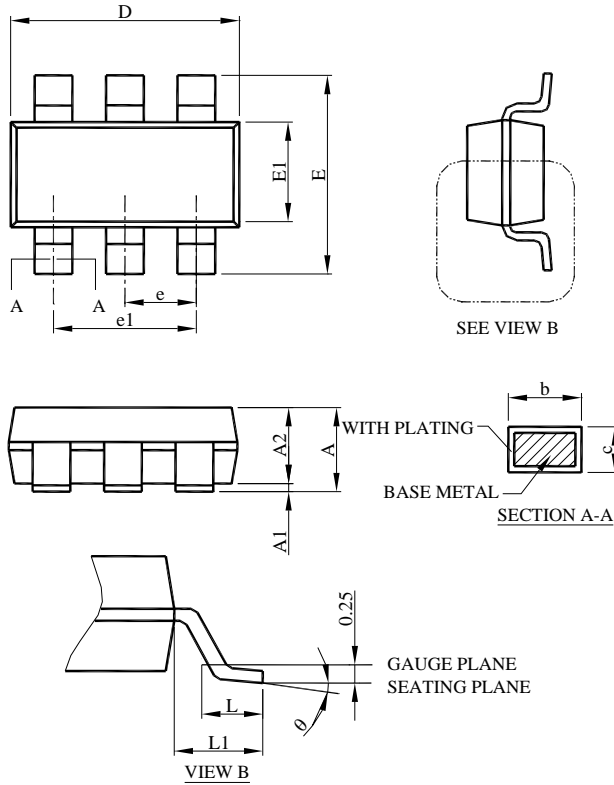

SYMBOL	SOT-26	
	MILLIMETERS	
	MIN.	MAX.
A	0.95	1.45
A1	0.05	0.15
A2	0.90	1.30
b	0.30	0.50
c	0.08	0.22
D	2.80	3.00
E	2.60	3.00
E1	1.50	1.70
e	0.95 BSC	
e1	1.90 BSC	
L	0.30	0.60
L1	0.60 REF	
θ	0°	8°

- Note:
- 1.Refer to JEDEC MO-178AB.
 - 2.Dimension D and E1 do not include mold flash, protrusions or gate burrs. Mold flash, protrusion or gate burrs shall not exceed 10 mil per side.
 - 3.Controlling dimension is millimeter; converted inch dimensions are not necessarily exact.

Note:

Information provided by AIC is believed to be accurate and reliable. However, we cannot assume responsibility for use of any circuitry other than circuitry entirely embodied in an AIC product; nor for any infringement of patents or other rights of third parties that may result from its use. We reserve the right to change the circuitry and specifications without notice.

Life Support Policy: AIC does not authorize any AIC product for use in life support devices and/or systems. Life support devices or systems are devices or systems which, (i) are intended for surgical implant into the body or (ii) support or sustain life, and whose failure to perform, when properly used in accordance with instructions for use provided in the labeling, can be reasonably expected to result in a significant injury to the user.