

1.0A Synchronous Step-Up Converter

FEATURES

- V_{IN} Start Up Voltage: 0.9V
- Output Voltage Range: from 2.5V to 5.5V.
- Up to 94% Efficiency
- Up to 1.0A Continuous Output Current
- Allow EN pin Floating
- Built-in current mode compensation
- Built-in Protection: Over Current, Over Voltage, Over Temperature
- Optional Active High/Low EN pin
- Logic Controlled Shutdown: $< 1\mu A$
- Output Disconnect by Shutdown Function
- Built-in Soft Start

APPLICATIONS

- Li-Ion Type Battery Operated Products
- Power Bank
- Handheld Devices
- Portable Products

TYPICAL APPLICATION CIRCUITS

DESCRIPTION

The AIC3417 is a high efficiency, step-up DC/DC converter with high light load efficiency. The true output disconnect function eliminates inrush current and allows V_{out} to go to zero during shutdown.

The AIC3417 is suited for high current boost application such as battery backup supplies or wireless devices powered by one Li-Ion battery or two Alkaline, Ni-Cd, Ni-MH battery.

The device includes a 50mΩ N-Ch MOSFET switch and a 60mΩ P-Ch MOSFET switch; it can provide high efficiency at 1.0A continuous output current. High efficiency is achieved at light load when PSM Mode operation is entered, where the IC's quiescent current is lower than 20μA on V_{out} .

The AIC3417 is available in the small 3mm x 3mm DFN-10 and SOP-8(EP) package.

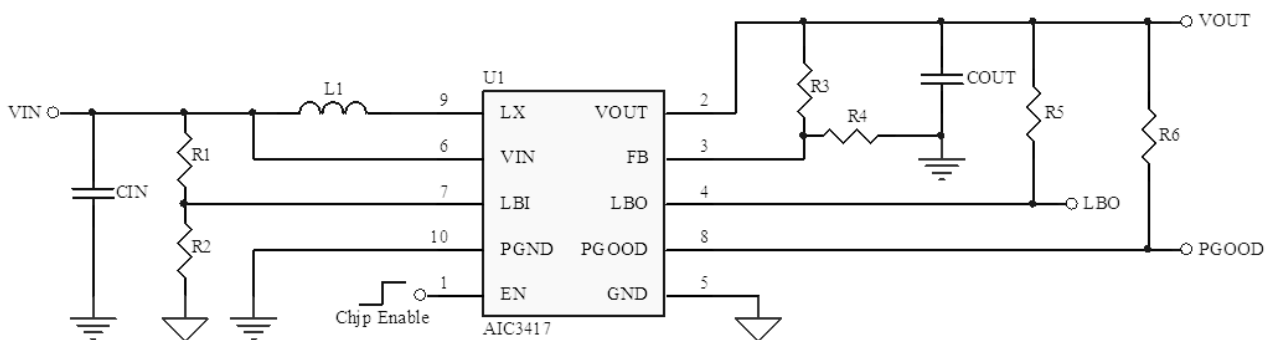

Typical Application Circuit for DFN-10 Package

ORDERING INFORMATION

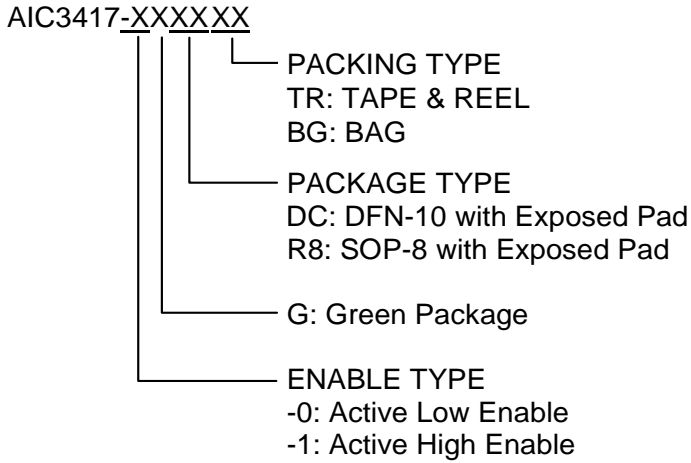

Example: AIC3417-1GDCTR
 → Active High Enable, in DFN-10 with Heat Sink Green Package and Tape & Reel Packing Type

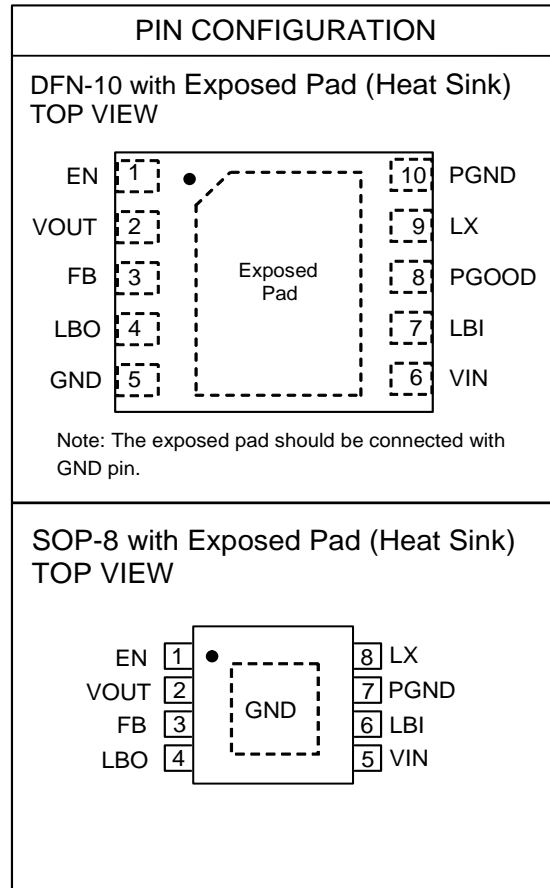

■ ABSOLUTE MAXIMUM RATINGS

Supply Input Voltage, VIN	-0.3 V to 6V
Output Voltage, VOUT.....	-0.3 V to 6V
Switch Output Voltage, LX.....	-0.3 V to 6V
Digital Input Voltage, EN, LBI.....	-0.3 V to 6V
Digital Output Voltage, LBO, PGOOD.....	-0.3 V to 6V
Other Pin.....	-0.3 V to 6V
Operating Ambient Temperature Range T _A	-40°C to 85°C
Operating Maximum Junction Temperature T _J	150°C
Storage Temperature Range T _{STG}	-65°C to 125°C
Lead Temperature (Soldering 10 Sec.).....	260°C
Thermal Resistance Junction to Case SOP-8 (Exposed Pad)*	15°C/W
Thermal Resistance Junction to Case DFN 10L (Exposed Pad)	20°C/W
Thermal Resistance Junction to Ambient SOP-8 (Exposed Pad)*.....	60°C/W
Thermal Resistance Junction to Ambient DFN 10L (Exposed Pad).....	50°C/W

(Assume no ambient airflow, no heatsink)

Absolute Maximum Ratings are those values beyond which the life of a device may be impaired.

*The package is placed on a two layers PCB with 2 ounces copper and 2 square inch, connected by 8 vias.

ELECTRICAL CHARACTERISTICS

 (Typical application circuit, $T_A=25^{\circ}\text{C}$, $V_{IN}=3.6\text{V}$, $V_{OUT}=5\text{V}$, Unless otherwise specified) (Note1)

PARAMETER	TEST CONDITION	SYMBOL	MIN	TYP	MAX	UNIT
Output Voltage Range	$I_{OUT}=0\text{A}$	V_{OUT}	2.5		5.5	V
Minimum Start Up Voltage	$I_{OUT}=0\text{A}$			0.9		V
Quiescent Current (Non-Switching)		I_{Q0}		20	30	μA
Shut Down Current (Oscillator no switching)	Active High, $EN= 0\text{V}$, $V_{IN}=1.1\text{V}$	I_{SD}		0.3	1	μA
	Active Low, $EN= V_{IN}$, $V_{IN}=1.1\text{V}$	I_{SD}		0.3	1	μA
Feedback Voltage	$I_{OUT}=0$	V_{FB}	0.49	0.5	0.51	mV
FB Input Leakage Current		I_{FB}		1	50	nA
Maximum Duty Cycle			80	88		%
Minimum Duty Cycle					0	%
NMOS Switch Leakage	$V_{SW}=5\text{V}$			0.1	5	μA
PMOS Switch Leakage	$V_{SW}=5\text{V}$			0.1	10	μA
NMOS Switch On Resistance				50		m Ω
PMOS Switch On Resistance				60		m Ω
EN High Threshold Voltage			1.2			V
EN Low Threshold Voltage					0.25	V
EN Input Current	$EN= 5.25\text{V}$	I_{EN}		10		μA
NMOS Current Limit Setting			2.1	2.7	3.4	A
Power Good threshold voltage	Rising referred to V_{FB}		91	95	99	%
Power Good Hysteresis				5		%
Power Good Delay				10		μS
LBI Voltage Threshold	LBI falling		0.485	0.5	0.515	V
LBI Voltage Hysteresis				10		mV
LBO Output Impedance				150		Ω
Over Temperature Protection				150		$^{\circ}\text{C}$
Over Temperature Hysteresis				25		$^{\circ}\text{C}$

Note 1: Specifications are production tested at $T_A=25^{\circ}\text{C}$. Specifications over the -40°C to 85°C operating temperature range are assured by design, characterization and correlation with Statistical Quality Controls (SQC).

Note 2: Once the output is started, the IC is not dependant upon the V_{IN} supply.

TYPICAL PERFORMANCE CHARACTERISTICS

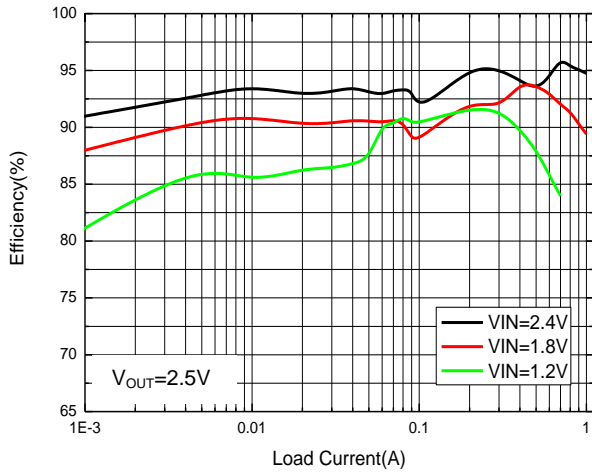

Fig. 1 Efficiency vs. Load Current

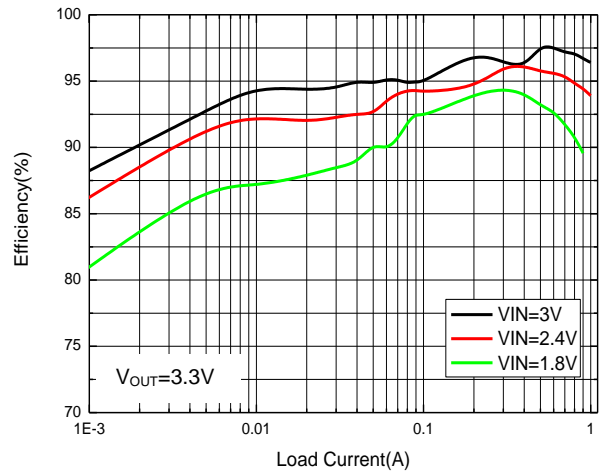

Fig. 2 Efficiency vs. Load Current

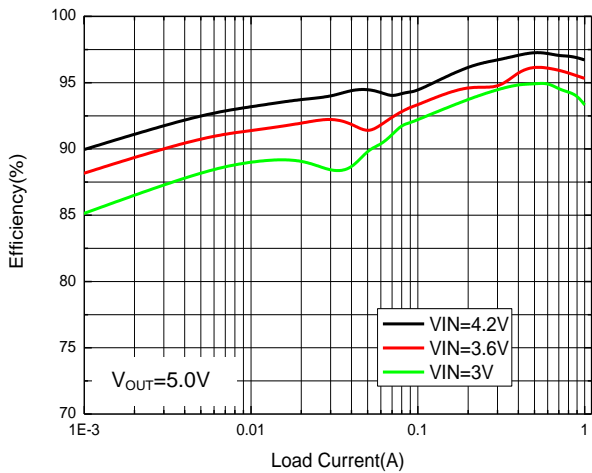

Fig. 3 Efficiency vs. Load Current

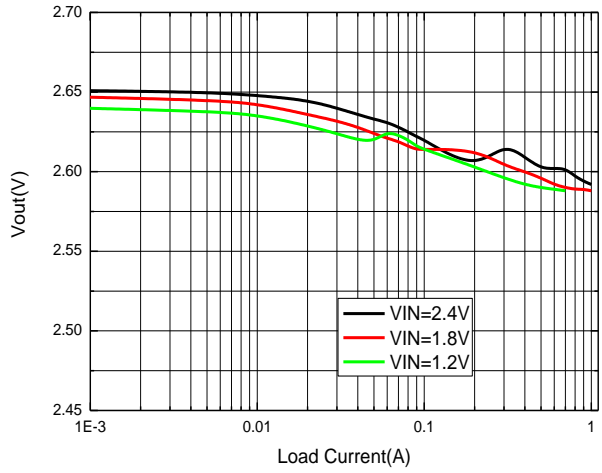

Fig. 4 Output Voltage vs. Load Current

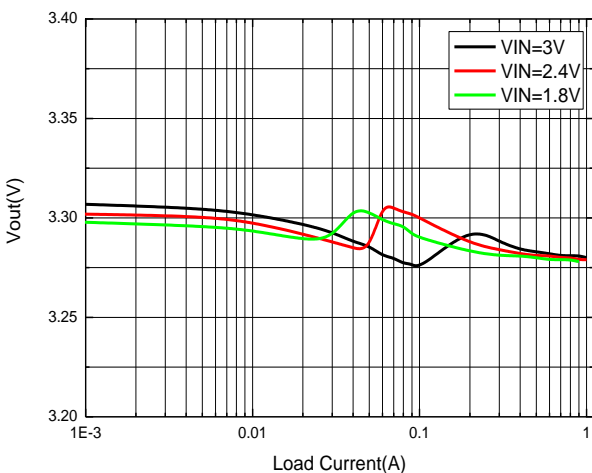

Fig. 5 Output Voltage vs. Load Current

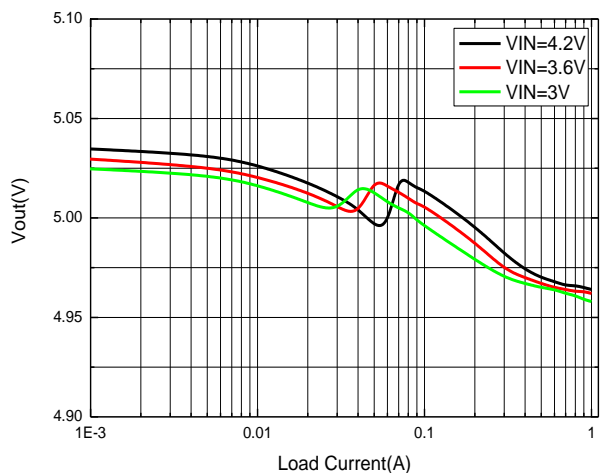

Fig. 6 Output Voltage vs. Load Current

TYPICAL PERFORMANCE CHARACTERISTICS (Continued)

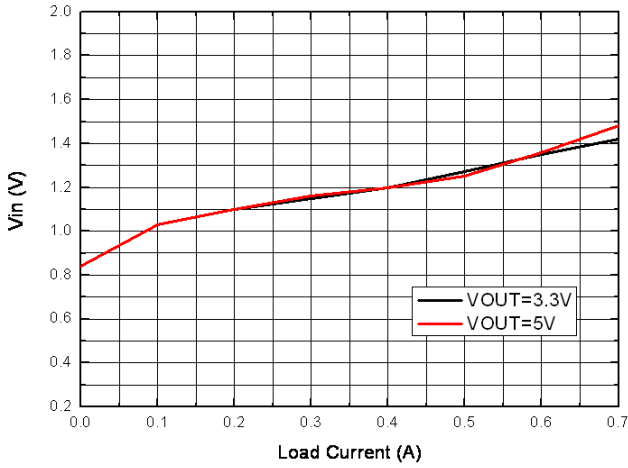

Fig. 7 Start-up Voltage vs. Load Current

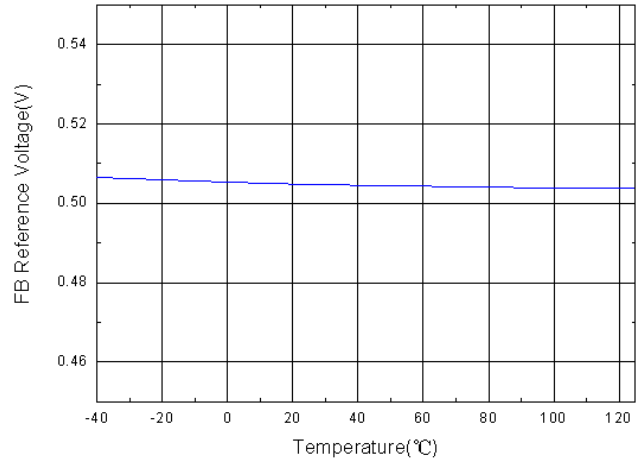

Fig. 8 Reference Voltage vs. Temperature

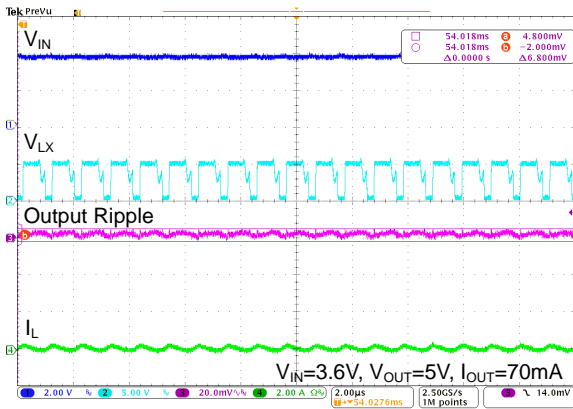

Fig. 9 Switching Waveform at DCM

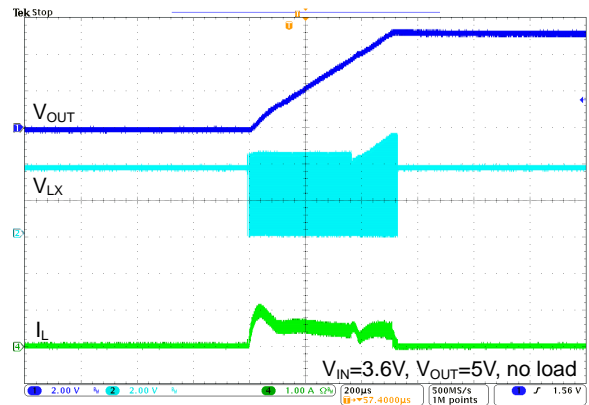

Fig. 10 Start-up Waveform

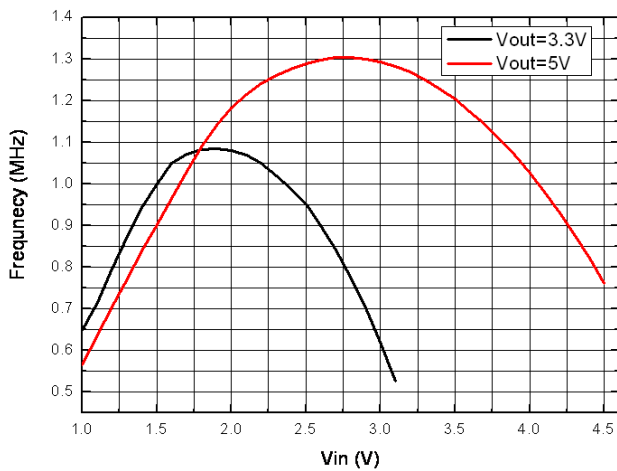
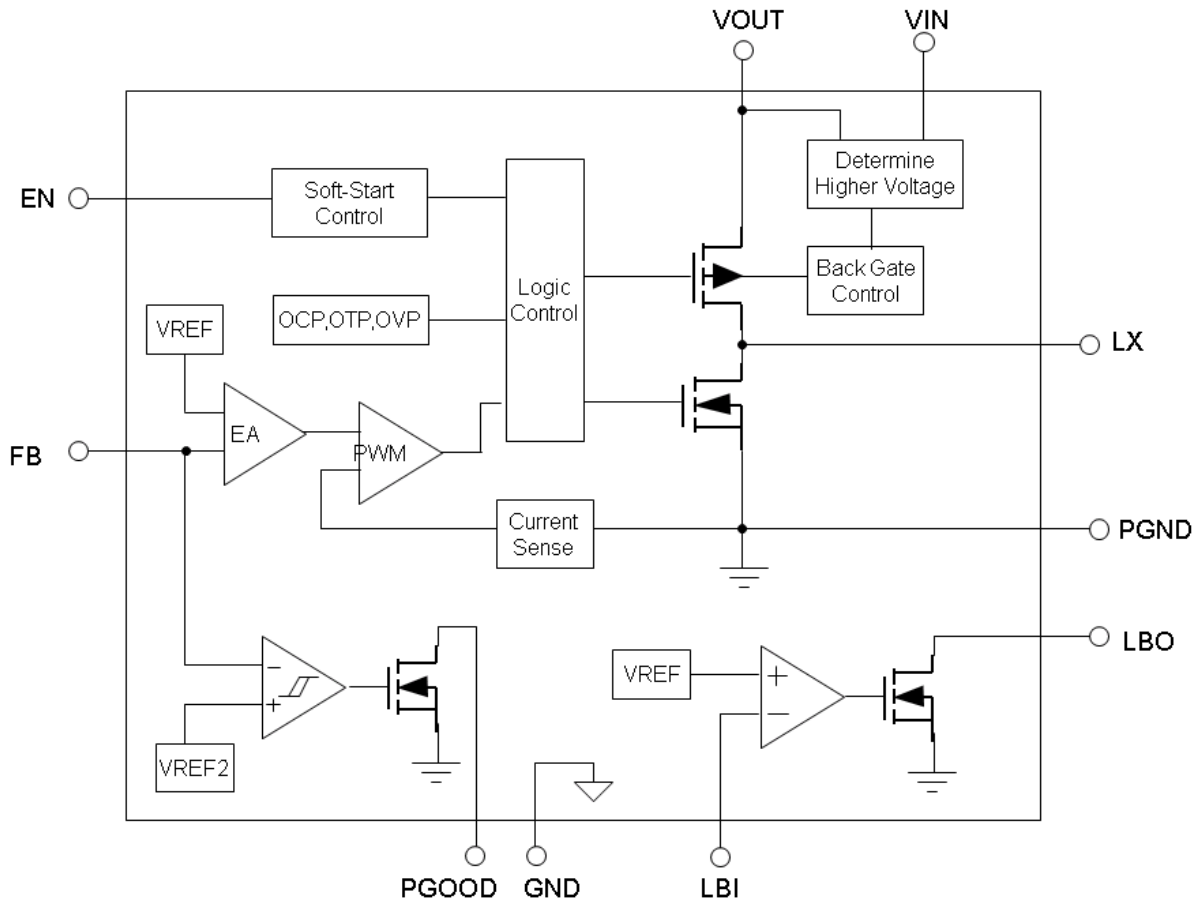

Fig. 11 Switching Frequency vs. Input Voltage

■ BLOCK DIAGRAM



Functional Block Diagram of AIC3417

■ PIN DESCRIPTIONS
(For DFN-10 PACKAGE)

Pin Number	Pin Name	Pin Function
1	EN	Logic Controlled Shutdown Input. There are two versions: Active High Version: EN = High: Normal Operation EN = Low or Floating: IC shutdown Active Low Version: EN = High or Floating: IC shutdown EN = Low: Normal Operation
2	VOUT	Output Voltage Sense and Drain of the Internal Synchronous Rectifier.
3	FB	Feedback Pin. This pin receives the feedback voltage from a resistive divider connect across the output.
4	LBO	Low-Battery Detector Output.
5	GND	Signal Ground.
6	VIN	Input Supply.
7	LBI	Low-Battery Detector Input.
8	PGOOD	Power Good Indicator.
9	LX	Switch Pin. Connect Inductor between VIN and this pin.
10	PGND	Power Ground.

■ PIN DESCRIPTIONS (Continued)
(For SOP-8 PACKAGE)

Pin Number	Pin Name	Pin Function
1	EN	Logic Controlled Shutdown Input. There are two versions: Active High Version: EN = High: Normal Operation EN = Low or Floating: IC shutdown Active Low Version: EN = High or Floating: IC shutdown EN = Low: Normal Operation
2	VOUT	Output Voltage Sense and Drain of the Internal Synchronous Rectifier.
3	FB	Feedback Pin. This pin receives the feedback voltage from a resistive divider connect across the output.
4	LBO	Low-Battery Detector Output.
5	VIN	Input Supply.
6	LBI	Low-Battery Detector Input.
7	PGND	Power Ground.
8	LX	Switch Pin. Connect Inductor between VIN and this pin.
9 (Exposed Pad)	GND	Signal Ground.

■ APPLICATION INFORMATION

The AIC3417 is a synchronous step-up DC-DC converter. It is based on constant Off Time/PSM controller topology. At the beginning of each clock cycle, the main switch (NMOS) is turned on and the inductor current starts to ramp. After the sense current signal equals the error amplifier (EA) output, the main switch is turned off and the synchronous switch (PMOS) is turned on. The device can operate with an input voltage below 2.5V; the typical start-up voltage is 0.9V.

Current Limit Protection

The over current protection can limit the main switch current. The output voltage will be dropped when over current is happened. The over current protection circuit will turn off the main switch once the current exceeds its threshold.

Zero Current Detection

The zero current comparator monitors the inductor current to the output and shuts off the synchronous rectifier when the inductor current reduces to zero. This prevents the inductor current from reversing in polarity and improves the efficiency at light load condition.

Device Shutdown

For the active high version, when EN is set logic high or floating, the AIC3417 is put into active mode operation. If EN is set logic low, the device is put into shutdown mode and consumes less than 1μA. At the shutdown mode, the synchronous switch will turn off and the output voltage of AIC3417 step-up converter will reduce to 0V. After start-up, the internal circuitry is supplied by VOUT. However, if shutdown mode is enabled, the internal circuitry will be supplied by the input source again.

Low-Battery Detection

AIC3417 contains an on-chip comparator with 10mV internal hysteresis for low battery detection. If the voltage at LBI falls below 0.5V, LBO (an open-drain output) sinks current to GND. The component value of

resistor R5 connecting between LBO pin and VOUT pin should be larger than 1MΩ.

Power Good Indicator

AIC3417 contains an on-chip comparator for power good detection. If the output voltage is lower than power good low threshold, PGOOD (an open-drain output) sinks current to GND.

Adjustable Output Voltage

An external resistor divider is used to set the output voltage. The output voltage of the switching regulator (V_{OUT}) is determined by the following equation:

$$V_{OUT} = V_{FB} \times \left(1 + \frac{R_3}{R_4} \right)$$

Where V_{FB} is 0.5V reference voltage.

Input Inductor Selection

A 1μH~3.3μH input inductor is recommended for most AIC3417 applications. Although small size and high efficiency are major concerns, the inductor should have low core losses at operation frequency and low DCR (copper wire resistance). It is important to ensure the inductor saturation current exceeding the peak inductor current in application to prevent core saturation. For CCM (Continuous Conduction Mode) operation, the peak inductor current can be calculated from:

$$\begin{aligned} I_{PEAK} &= I_{IN(MAX)} + \frac{V_{IN(MIN)} \cdot D_{(MAX)}}{2 \times f_s \cdot L} \\ &= \frac{I_{OUT(MAX)} \cdot V_{OUT}}{\eta \cdot V_{IN(MIN)}} + \frac{V_{IN(MIN)} \cdot D_{(MAX)}}{2 \times f_s \cdot L} \end{aligned}$$

Input Capacitor Selection

Surface mount 10μF or greater, X5R or X7R, ceramic capacitor is suggested for the input capacitor. The input capacitor provides a low impedance loop for the edges of pulsed current drawn by the AIC3417. Low ESR/ESL X7R and X5R ceramic capacitors are ideal for this function. To minimize stray inductance, the capacitor should be placed as close as possible to the IC. This keeps the high frequency content of the input current

localized, minimizing EMI and input voltage ripple. Always examine the ceramic capacitor DC voltage coefficient characteristics to get the proper value.

Output Capacitor Selection

The output capacitor limits the output ripple and provides holdup during large load transitions. Two 22 μ F, X5R or X7R, ceramic capacitors are suggested for the output capacitor. Typically the recommended capacitor range provides sufficient bulk capacitance to stabilize the output voltage during large load transitions and has the low ESR and ESL characteristics necessary for low

output voltage ripple.

PCB Layout Guidance

This is a considerably high frequency for DC-DC converters. PCB layout is important to guarantee satisfactory performance. It is recommended to make traces of the power loop, especially where the switching node is involved, as short and wide as possible. First of all, the inductor, input and output capacitor should be as close to the device as possible. Feedback and shutdown circuits should avoid the proximity of large AC signals involving the power inductor and switching node.

■ PHYSICAL DIMENSION

● DFN -10L-3X3

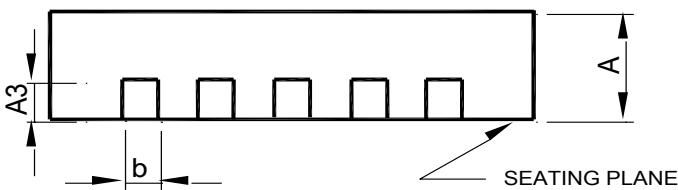
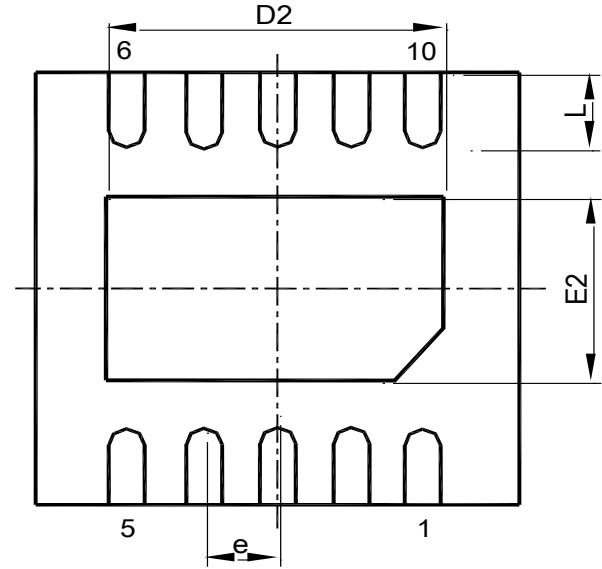
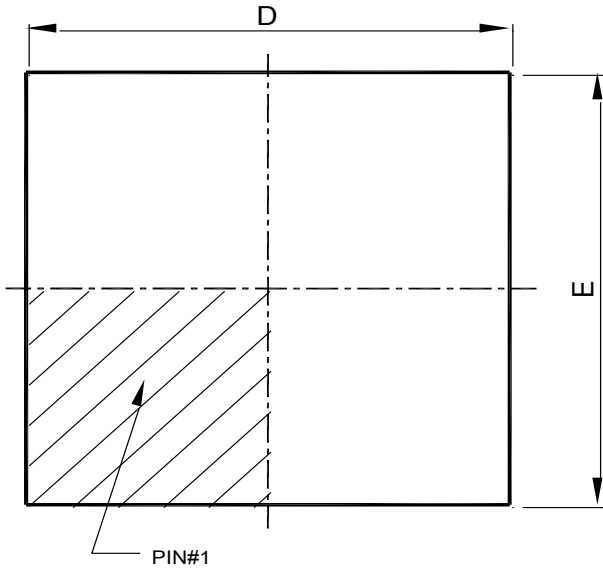

SYMBOL	DFN 10L-3x3x0.75-0.5mm	
	MILLIMETERS	
	MIN.	MAX.
A	0.70	0.80
A3	0.20 BSC	
b	0.18	0.30
D	2.90	3.10
D2	2.20	2.70
E	2.90	3.10
E2	1.40	1.80
e	0.5 BSC	
L	0.30	0.50

Note : 1. DIMENSION AND TOLERANCING CONFORM TO ASME Y14.5M-1994.
 2. CONTROLLING DIMENSIONS : MILLIMETER , CONVERTED INCH DIMENSION ARE NOT NECESSARILY EXACT.

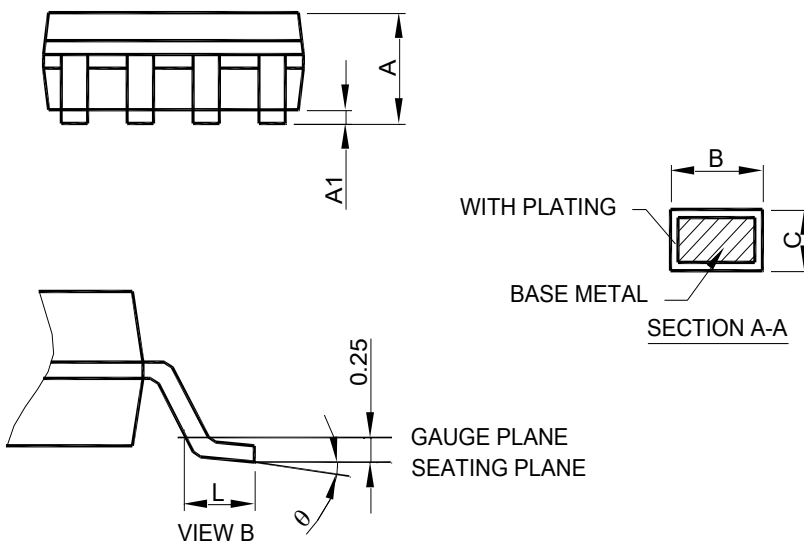
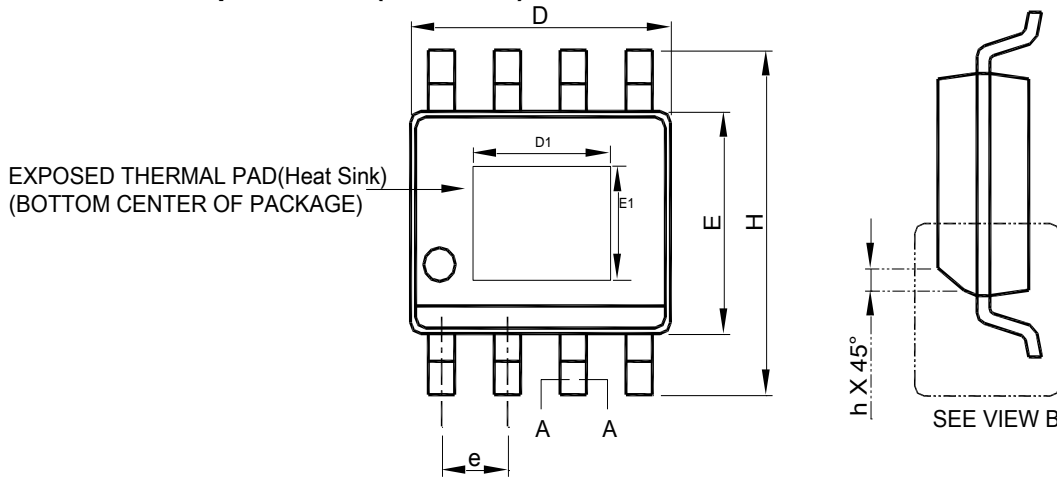
PHYSICAL DIMENSION (Continued)
SOP-8 Exposed Pad (Heat Sink)

SYMBOL	SOP-8 Exposed Pad(Heat Sink)	
	MILLIMETERS	
	MIN.	MAX.
A	1.35	1.75
A1	0.00	0.15
B	0.31	0.51
C	0.17	0.25
D	4.80	5.00
D1	1.50	3.50
E	3.80	4.00
E1	1.0	2.55
e	1.27 BSC	
H	5.80	6.20
h	0.25	0.50
L	0.40	1.27
θ	0°	8°

- Note : 1. Refer to JEDEC MS-012E.
 2. Dimension "D" does not include mold flash, protrusions or gate burrs. Mold flash, protrusion or gate burrs shall not exceed 6 mil per side .
 3. Dimension "E" does not include inter-lead flash or protrusions.
 4. Controlling dimension is millimeter, converted inch dimensions are not necessarily exact.

Note:

Information provided by AIC is believed to be accurate and reliable. However, we cannot assume responsibility for use of any circuitry other than circuitry entirely embodied in an AIC product; nor for any infringement of patents or other rights of third parties that may result from its use. We reserve the right to change the circuitry and specifications without notice.

Life Support Policy: AIC does not authorize any AIC product for use in life support devices and/or systems. Life support devices or systems are devices or systems which, (i) are intended for surgical implant into the body or (ii) support or sustain life, and whose failure to perform, when properly used in accordance with instructions for use provided in the labeling, can be reasonably expected to result in a significant injury to the user.