

Built-in OVP White LED Step-Up Converter

FEATURES

- Built-In Open Circuit Protection
- Over Voltage Protection
- Efficiency Up to 83% at $V_{IN}=4.2V$, 3LEDs, $I_{LED}=20mA$
- 1.2MHz Fixed Switching Frequency
- Drives Up to 5LEDs in series
- 2.5V to 5.5V Input Voltage
- Low Supply Current: 150 μA
- Matches LED Current
- Requires Tiny Inductor and Capacitors
- TSOT-23-6, and SOT-23-6 Packages

APPLICATIONS

- Cellular Phones
- PDAs
- DSCs
- Handheld Devices
- White LED Display Backlighting

DESCRIPTION

AIC3643 is a current-mode pulse-width-modulation (PWM), step-up DC/DC converter designed to drive white LEDs with a constant current to provide backlight in hand-held devices. Series connection of LEDs provides identical LED currents resulting in uniform brightness. This configuration eliminates the need of ballast resistors. The built-in open load protection prevents the damage resulting from an open circuit condition. Also low 100mV feedback voltage minimizes power loss in the current setting resistor for better efficiency.

AIC3643 is a step-up PWM converter, which includes an internal N-channel MOSFET switch for high efficiency. The high switching frequency, 1.2MHz, allows the use of tiny external components.

AIC3643 is available in a space-saving TSOT-23-6, and SOT-23-6 packages.

TYPICAL APPLICATION CIRCUIT

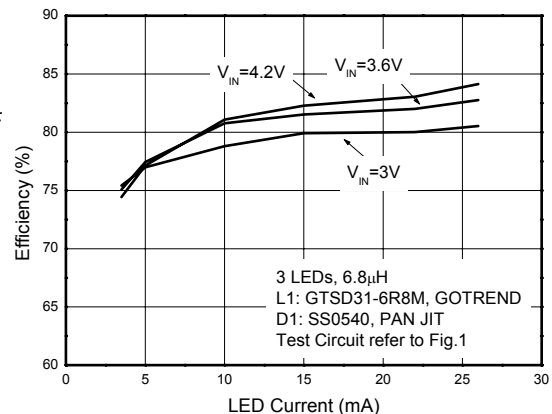
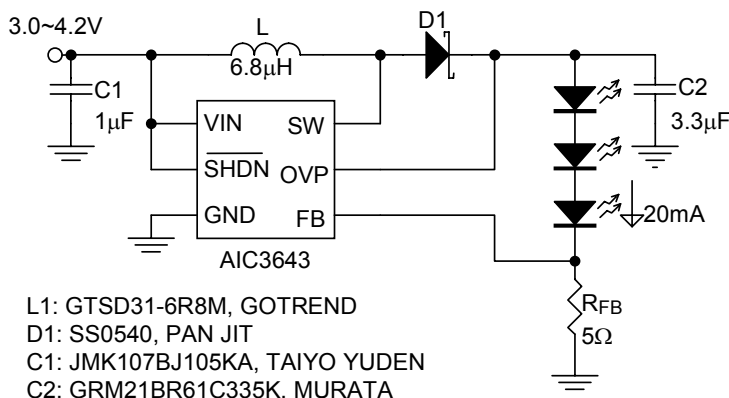
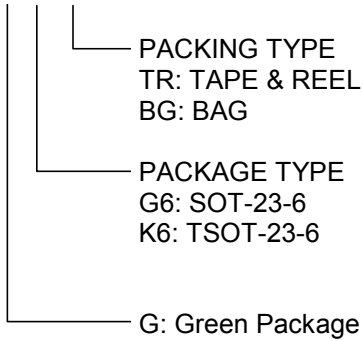

Fig. 1 Li-Ion Powered Driver for Three White LEDs

ORDERING INFORMATION

AIC3643XXXXX

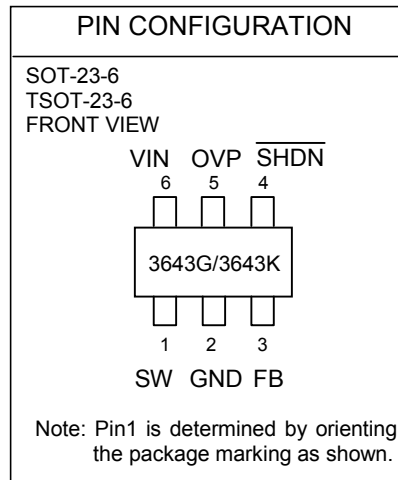

Example: AIC3643GG6TR
 → in SOT-23-6 Green Package &
 Tape & Reel Packing Type

Marking

Part No.	Marking
AIC3643GG6	3643G
AIC3643GK6	3643K

■ ABSOLUTE MAXIMUM RATINGS

Input Voltage (VIN)	6V	
SW Voltage	33V	
FB Voltage	6V	
$\overline{\text{SHDN}}$ Voltage	6V	
OVP Voltage	34V	
Operating Temperature Range	-40°C to 85°C	
Storage Temperature Range	-65°C to 150°C	
Maximum Junction Temperature	150°C	
Lead Temperature (Soldering, 10 sec)	260°C	
Thermal Resistance Junction to Case	SOT-23-6	115°C/W
	TSOT-23-6	115°C/W
Thermal Resistance Junction to Ambient	SOT-23-6	250°C/W
	TSOT-23-6	250°C/W

Absolute Maximum Ratings are those values beyond which the life of a device may be impaired.

ELECTRICAL CHARACTERISTICS

 ($V_{\overline{\text{SHDN}}}=1.5\text{V}$, $V_{\text{IN}}=3\text{V}$, $T_{\text{A}}=25^{\circ}\text{C}$, unless otherwise specified.) (Note 1)

PARAMETER	SYMBOL	TEST CONDITIONS	MIN	TYP	MAX	UNIT
Operating Voltage	V_{IN}		2.5		5.5	V
Supply Current	I_{IN}	Switching		1	3	mA
		Non switching		150	270	μA
		$V_{\overline{\text{SHDN}}} = 0\text{V}$		0.1	1.0	
ERROR AMPLIFIER						
Feedback Voltage	V_{FB}		90	100	110	mV
FB Input Bias Current	I_{FB}	$V_{\text{FB}}=100\text{mV}$		1		nA
OSCILLATOR						
Switching Frequency	f_{OSC}		0.8	1.2	1.6	MHz
Maximum Duty Cycle	D		91	94		%
POWER SWITCH						
SW ON Resistance	$R_{\text{DS(ON)}}$			1.4	2.5	Ω
Switch Leakage Current	$I_{\text{SW(OFF)}}$	$V_{\text{SW}}=33\text{V}$		0.1	1	μA
Switch Current Limit	I_{IL}		0.65	1		A
CONTROL INPUT						
$\overline{\text{SHDN}}$ Voltage High	V_{IH}	ON	1.5			V
$\overline{\text{SHDN}}$ Voltage Low	V_{IL}	OFF			0.3	V
OVER VOLTAGE PROTECTION						
OVP Input Resistance	R_{OVP}		0.8	1.2	1.6	$\text{M}\Omega$
OVP Threshold	V_{OVP}	1V Hysteresis typical	22	28	32	V

Note 1: Specifications are production tested at $T_{\text{A}}=25^{\circ}\text{C}$. Specifications over the -40°C to 85°C operating temperature range are assured by design, characterization and correlation with Statistical Quality Controls (SQC).

TYPICAL PERFORMANCE CHARACTERISTICS

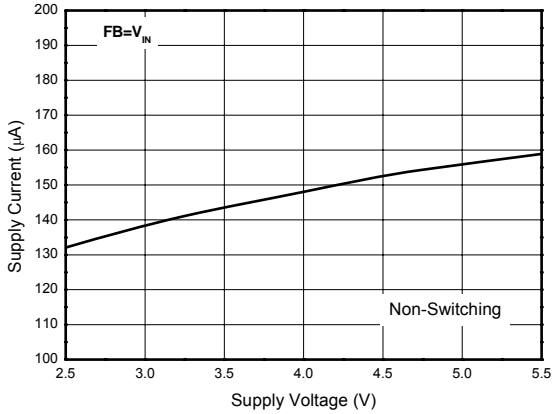

Fig. 2 Supply Current vs. Supply Voltage

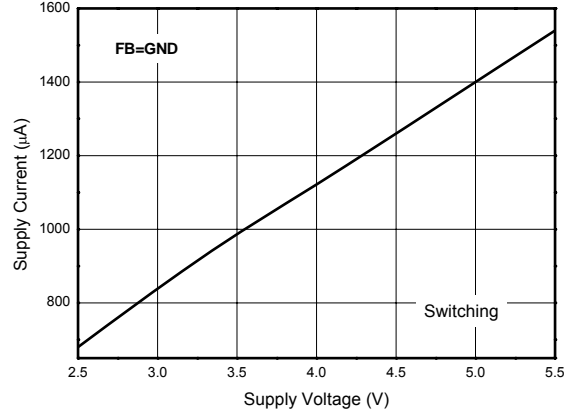

Fig. 3 Supply Current vs. Supply Voltage

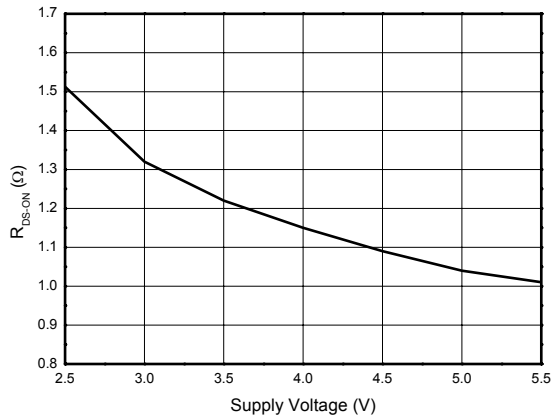

Fig. 4 R_{DS_ON} vs. Supply Voltage

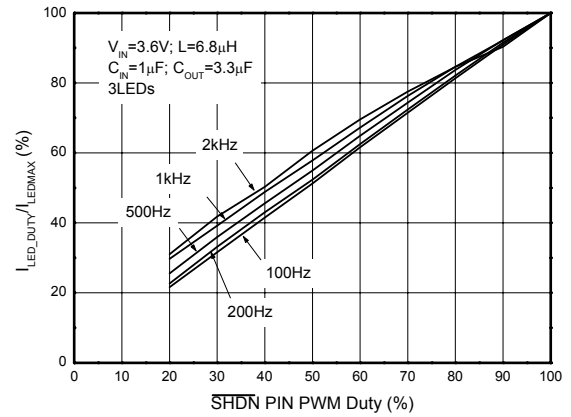

Fig. 5 Dimming Control by Shutdown Pin

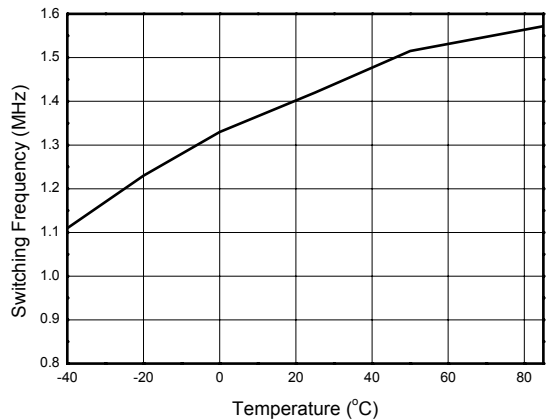

Fig. 6 Switching Frequency vs. Temperature

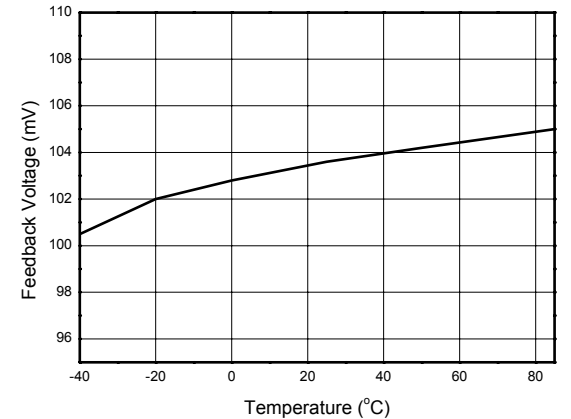

Fig. 7 Feedback Voltage vs. Temperature

TYPICAL PERFORMANCE CHARACTERISTICS (Continued)

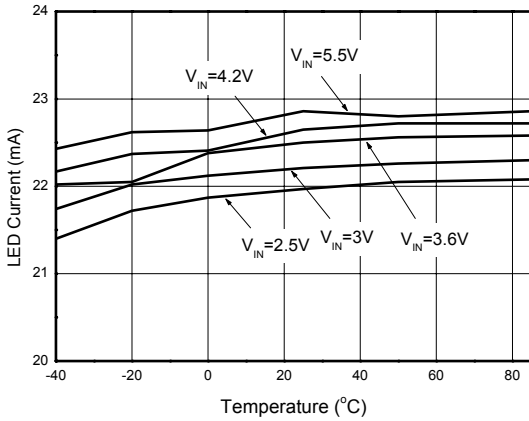
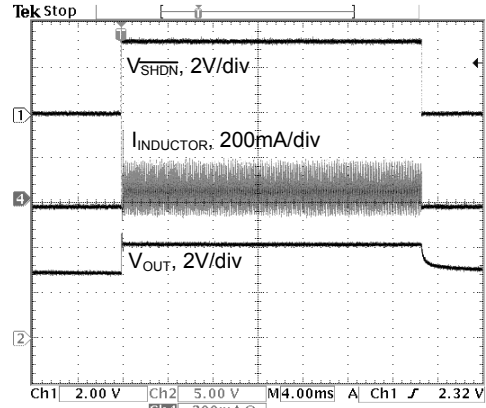
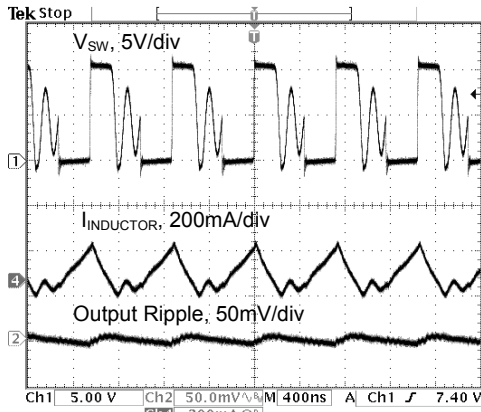

Fig. 8 LED Current vs. Temperature



$V_{IN}=3V$; 3LEDs; $L=6.8\mu F$; $C_{OUT}=3.3\mu F$; $I_{LED}=20mA$

Fig. 9 Start Up from Shutdown



$V_{IN}=3.6V$; 3LEDs; $L=6.8\mu F$; $C_{OUT}=3.3\mu F$; $I_{LED}=20mA$

Fig. 10 Operation Waveform

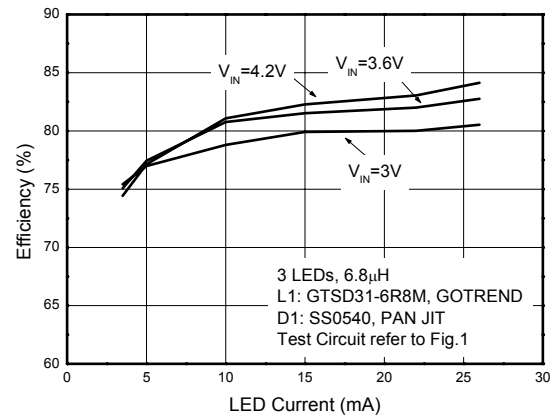

Fig. 11 3LEDs Efficiency vs. LED Current

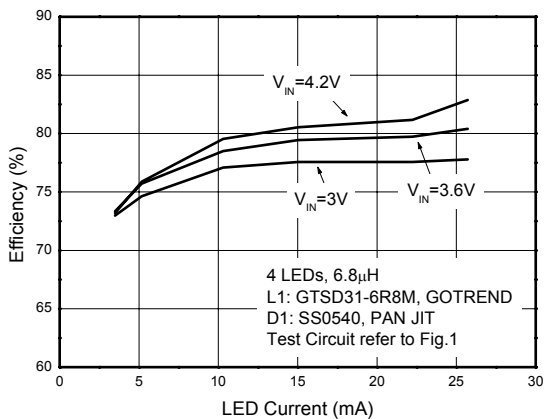

Fig. 12 4LEDs Efficiency vs. LED Current

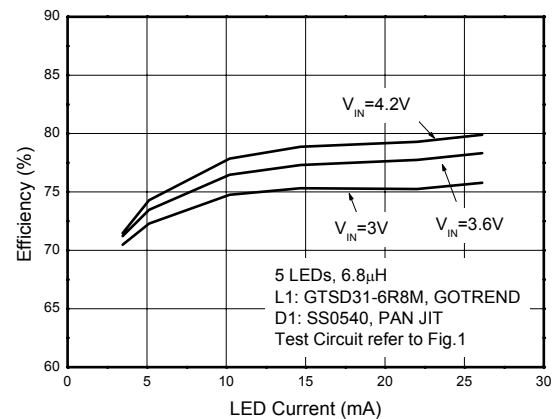
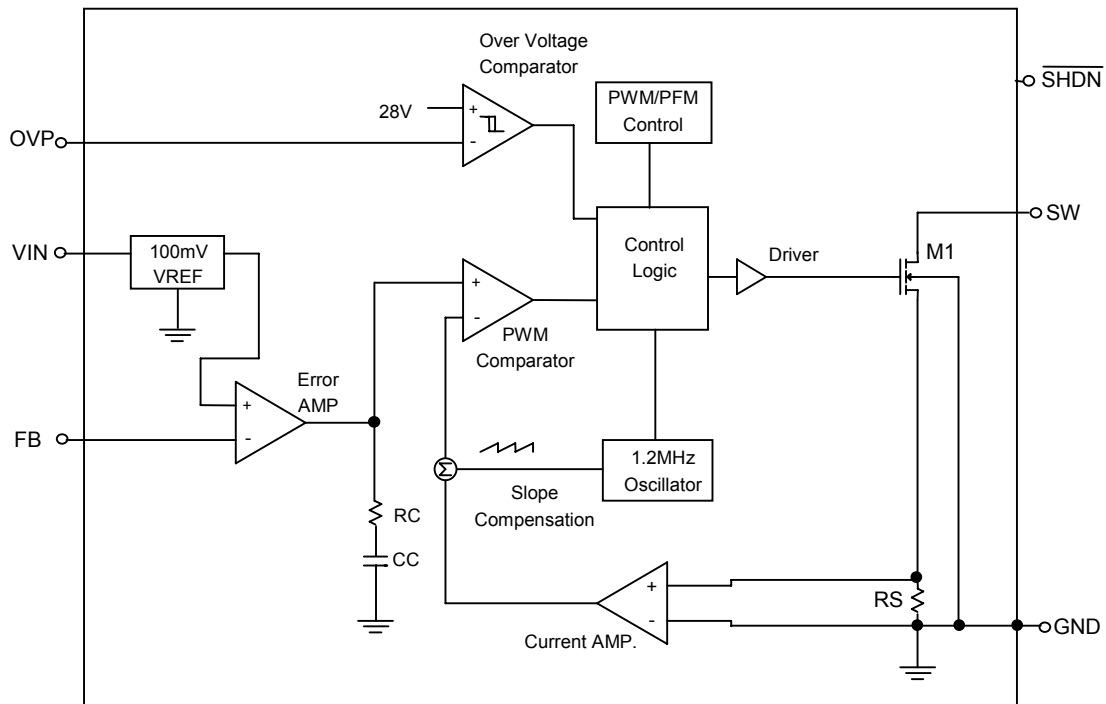

Fig. 13 5LEDs Efficiency vs. LED Current

■ BLOCK DIAGRAM



■ PIN DESCRIPTIONS

- PIN 1: SW - Switch pin. Connect inductor/diode here. Minimize trace area at this pin to reduce EMI.
- PIN 2: GND - Ground pin. Tie directly to local ground plane.
- PIN 3: FB - Feedback pin. Reference voltage is 100mV. Connect cathode of lowest LED and resistor here. Calculate resistor value to obtain LED current according to the formula:

$$R_{FB} = 100\text{mV}/I_{LED}$$

- PIN 4: $\overline{\text{SHDN}}$ - Shutdown pin. Tie to higher than 1.5V to enable device, 0.3V or less to disable device.
- PIN 5: OVP - Overvoltage protection. When VOUT is greater than 28V, the internal MOSFET turns off.
- PIN 6: VIN - Power input pin. Bypass VIN to GND with a capacitor sitting as close to VIN as possible.

■ APPLICATION INFORMATION

Inductor Selection

A 6.8μH inductor is recommended for most AIC3643 applications. Although small size and high efficiency are major concerns, the inductor should have low core losses at 1.2MHz and low DCR (copper wire resistance). It is important to ensure the inductor saturation current exceeding the peak inductor current in application to prevent core saturation. For CCM (Continuous Conduction Mode) operation, the peak inductor current can be calculated from:

$$I_{PEAK} = I_{IN(MAX)} + \frac{V_{IN(MIN)} \cdot D_{(MAX)}}{2 \times f_{OSC} \cdot L}$$

$$= \frac{I_{LED(MAX)} \cdot V_{OUT}}{\eta \cdot V_{IN(MIN)}} + \frac{V_{IN(MIN)} \cdot D_{(MAX)}}{2 \times f_{OSC} \cdot L}$$

Capacitor Selection

The small size of ceramic capacitors makes them ideal for AIC3643 applications. X5R and X7R types are recommended because they retain their capacitance over wider ranges of voltage and temperature than other types, such as Y5V or Z5U. 1μF input capacitor with 3.3μF output capacitor are sufficient for most AIC3643 applications.

Diode Selection

Schottky diodes, with their low forward voltage drop and fast reverse recovery, are the ideal choices for AIC3643 applications. The forward voltage drop of an Schottky diode represents the conduction losses in the diode, while the diode capacitance (CT or CD) represents the switching losses. For diode selection, both forward voltage drop and diode capacitance need to be considered. In addition, the rating of selected Schottky diode should be able to handle the output voltage and the maximum peak diode current.

LED Current Control

LED current is controlled by feedback resistor (R_{FB} in Figure 1). The feedback reference voltage is 100mV. The LED current is $100mV/R_{FB}$. In

order to have accurate LED current, precision resistors are preferred (1% recommended). The formula for R_{FB} selection is shown below.

$$R_{FB} = \frac{100mV}{I_{LED}}$$

Open-Circuit Protection

In the cases of output open circuit, when the LEDs are disconnected from the circuit or the LEDs fail, the feedback voltage will be zero. AIC3643 will then switch to a high duty cycle resulting in a high output voltage, which may cause SW pin voltage to exceed its maximum 33V rating. Connect built-in OVP (Over Voltage Protection) pin to output terminal to prevent the damage resulting from an open circuit condition.

Dimming Control

There are three different ways of dimming control circuits as follows:

1. Using a PWM signal

PWM brightness control provides the widest dimming range by pulsing the LEDs on and off at full and zero current, respectively. The change of average LED current depends on the duty cycle of the PWM signal. Typically, a 0.1kHz to 2kHz PWM signal is used. Two applications of PWM dimming with AIC3643 are shown in Figure 14 and Figure 15. One, as Figure 14, uses PWM signal to drive \overline{SHDN} pin directly for dimming control. The other, as Figure 15, employs PWM signal going through a resistor to drive FB pin. If the \overline{SHDN} pin is used, the increase of duty cycle results in LED brightness enhancement. If the FB pin is used, on the contrary, the increase of duty cycle will decrease its brightness. In this application, LEDs are dimmed by FB pin and turned off completely by \overline{SHDN} .

2. Using a DC Voltage

For some applications, the preferred method of a dimming control uses a variable DC voltage to adjust LED current. The dimming control using a DC voltage is shown in Figure 16. With a V_{DC}

ranging from 0V to 5V, the selection of resistors in Figure 16 results in dimming control of LED current from 20mA to 0mA, respectively.

3. Using a Filtered PWM Signal

Filtered PWM signal can be considered as an adjustable DC voltage. It can be used to replace the variable DC voltage source in dimming control. The circuit is shown in Figure 17.

Layout Consideration

In order to ensure a proper operation of AIC3643, the following points should be managed comprehensively.

1. The input capacitor and V_{IN} should be placed

as close as possible to each other to reduce the input ripple voltage.

2. The output loop, which is consisted of the inductor, the internal power switch, the Schottky diode and the output capacitor, should be kept as small as possible.
3. The routes with large current should be kept short and wide.
4. Logically the large current on the converter should flow at the same direction.
5. The FB pin should be connected to the feedback resistors directly and the route should be away from the noise sources.

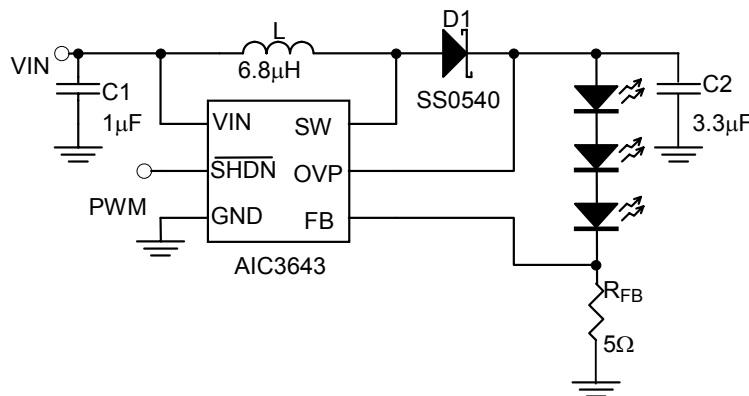

Fig. 14 Dimming Control with a PWM Signal

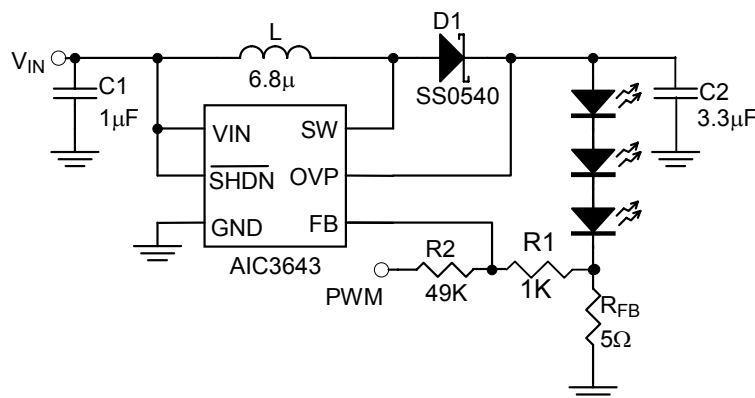

Fig. 15 Dimming Control Using a PWM Signal

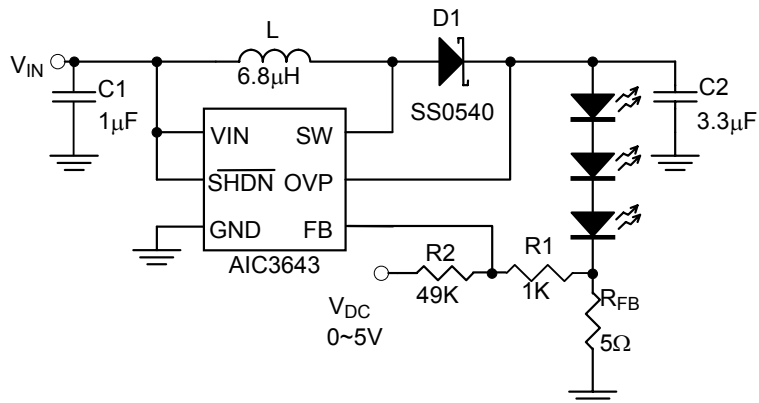

Fig. 16 Dimming Control Using a DC Voltage

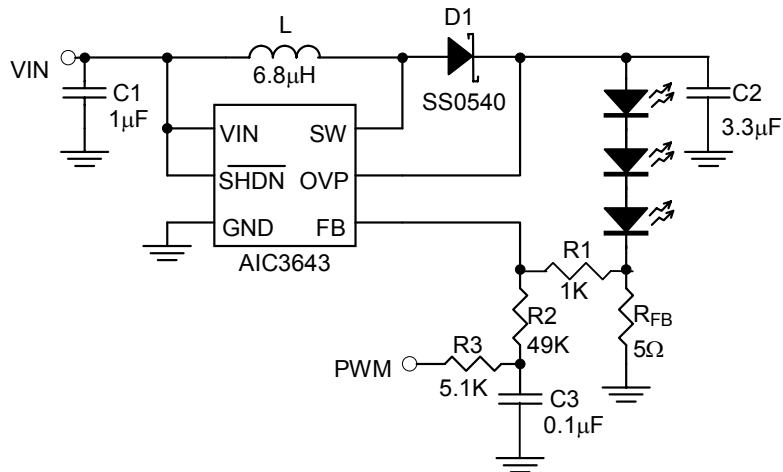

Fig. 17 Dimming Control Using a Filter PWM Signal

■ APPLICATION EXAMPLE

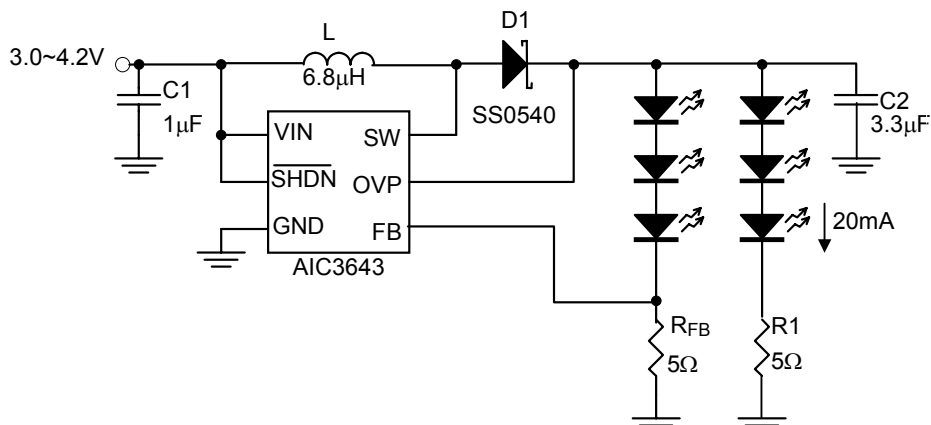
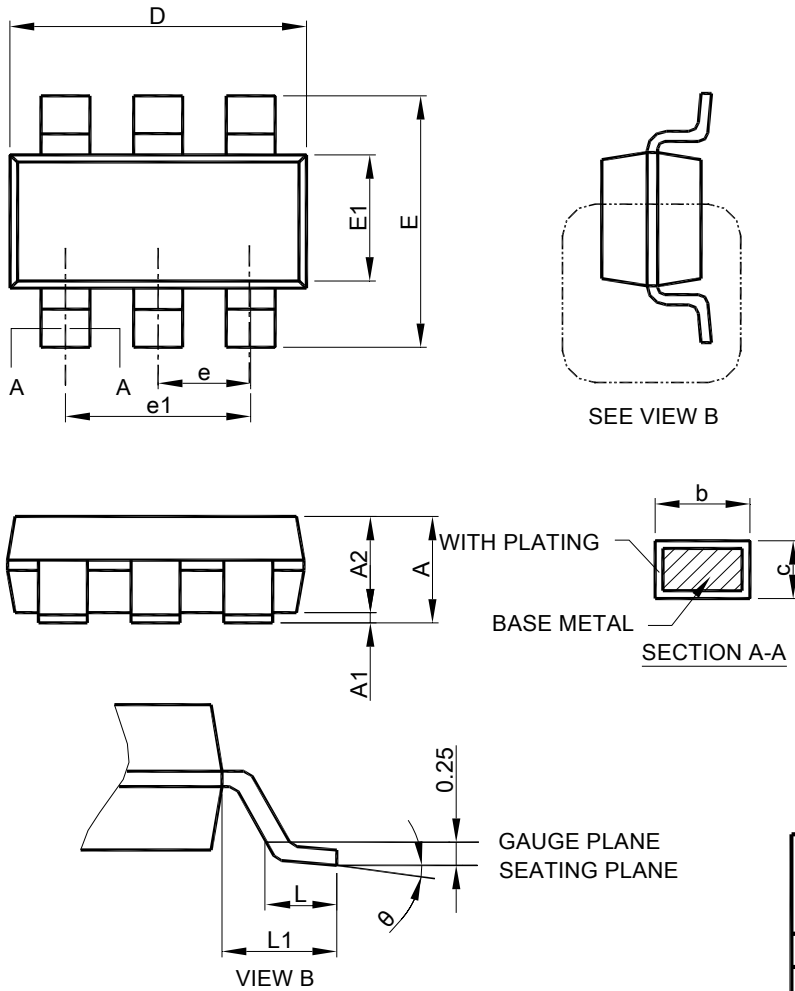

Fig. 18 Six White LEDs Application in Li-Ion Battery

PHYSICAL DIMENSIONS (unit: mm)
SOT-23-6 PACKAGE OUTLINE DRAWING

- Note : 1. Refer to JEDEC MO-178AB.
 2. Dimension "D" does not include mold flash, protrusions or gate burrs. Mold flash, protrusion or gate burrs shall not exceed 10 mil per side.
 3. Dimension "E1" does not include inter-lead flash or protrusions.
 4. Controlling dimension is millimeter, converted inch dimensions are not necessarily exact.

SYMBOL	SOT-23-6	
	MILLIMETERS	
	MIN.	MAX.
A	0.95	1.45
A1	0.05	0.15
A2	0.90	1.30
b	0.30	0.50
c	0.08	0.22
D	2.80	3.00
E	2.60	3.00
E1	1.50	1.70
e	0.95 BSC	
e1	1.90 BSC	
L	0.30	0.60
L1	0.42 REF	
θ	0°	8°

● TSOT-23-6 PACKAGE OUTLINE DRAWING

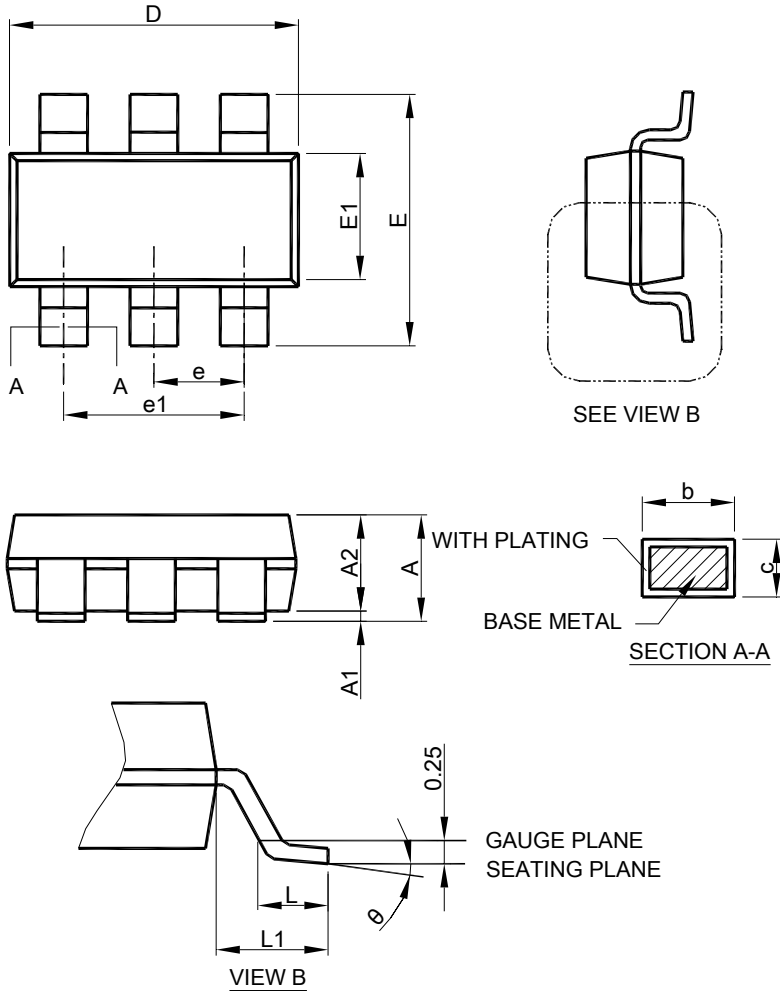

- Note :
1. Refer to JEDEC MO-193AA.
 2. Dimension "D" does not include mold flash, protrusions or gate burrs. Mold flash, protrusion or gate burrs shall not exceed 6 mil per side.
 3. Dimension "E1" does not include inter-lead flash or protrusions.
 4. Controlling dimension is millimeter, converted inch dimensions are not necessarily exact.

SYMBOL	TSOT-23-6	
	MILLIMETERS	
	MIN.	MAX.
A	-	1.00
A1	0	0.10
A2	0.70	0.90
b	0.30	0.50
c	0.08	0.22
D	2.80	3.00
E	2.60	3.00
E1	1.50	1.70
e	0.95 BSC	
e1	1.90 BSC	
L	0.30	0.60
L1	0.60 REF	
θ	0°	8°

Note:

Information provided by AIC is believed to be accurate and reliable. However, we cannot assume responsibility for use of any circuitry other than circuitry entirely embodied in an AIC product; nor for any infringement of patents or other rights of third parties that may result from its use. We reserve the right to change the circuitry and specifications without notice.

Life Support Policy: AIC does not authorize any AIC product for use in life support devices and/or systems. Life support devices or systems are devices or systems which, (I) are intended for surgical implant into the body or (ii) support or sustain life, and whose failure to perform, when properly used in accordance with instructions for use provided in the labeling, can be reasonably expected to result in a significant injury to the user.