



## Down Converter Mixer with Fractional-N Frequency Synthesizer and VCO

# AK1572

### 1. Overview

AK1572 is the down-converter mixer with fractional-N frequency synthesizer and integrated VCO. AK1572 is targeted at the application that requires a high linearity performance in frequency conversion. The mixer block is comprised of the single input and the differential output. Input frequency range is from 690MHz to 4000MHz and output frequency range is from 20MHz to 500MHz. The current consumption and the analog performance can be adjusted by a resistance connected to BIAS pin. The power supply voltage of mixer covers 4.75 to 5.25V.

The local signal output frequency range is from 262.5MHz to 4400MHz generated by internal VCO, synthesizer and divider. Not only a local signal is supplied to an internal mixer, but also can be taken to outside. A power supply voltage range of VCO/synthesizer is 2.7V to 3.6V or 4.75V to 5.25V. The CPU interface is 24bit serial data and its voltage is ranging from 2.7V to 5.25V

### 2. Features

#### General

- |                          |                           |   |
|--------------------------|---------------------------|---|
| <input type="checkbox"/> | RF input frequency Range  | 690MHz to 4.0GHz  |
| <input type="checkbox"/> | IF output frequency Range | 20MHz to 500MHz   |
| <input type="checkbox"/> | LO frequency Range        | 262.5MHz to 4.4GHz  |
| <input type="checkbox"/> | Supply Voltage :          | 4.75V to 5.25 V (Mixer)<br>2.7 to 3.6V / 4.75 to 5.25V (Synthesizer /VCO) |
| <input type="checkbox"/> | Current Consumption:      | 150mA typ.  |
| <input type="checkbox"/> | Package:                  | 32pin QFN (0.5mm pitch, 5mm × 5mm × 0.85mm)                               |
| <input type="checkbox"/> | Operating Temperature :   | -40°C ~ 85°C  |

#### Synthesizer/VCO

- |                          |                        |  |
|--------------------------|------------------------|--|
| <input type="checkbox"/> | Normalized Phase Noise | -218dBc/Hz                             |
| <input type="checkbox"/> | Phase Noise            | -111dBc/Hz @100kHz $f_o=2.1\text{GHz}$ |

#### Mixer ( $f_r=2\text{GHz}$ )

- |                          |  |             |
|--------------------------|--|-------------|
| <input type="checkbox"/> | Conversion Gain                              | -1.5dB typ. |
| <input type="checkbox"/> | Input 3 <sup>rd</sup> orders intercept point | +23dBm typ. |
| <input type="checkbox"/> | Noise Figure                                 | 14dB typ.   |

#### Application

Microwave Radio Link  
Cellular BTS / Repeater

<b>3. Table of Content</b>
----------------------------

<b>1. Overview</b>	<b>1</b>
<b>2. Features</b>	<b>1</b>
<b>3. Table of Content</b>	<b>2</b>
<b>4. Block Diagram and Function</b>	<b>3</b>
<b>5. Pin function Description and Assignment</b>	<b>4</b>
<b>6. Absolute Maximum Rating</b>	<b>6</b>
<b>7. Recommended Operating Range</b>	<b>7</b>
<b>8. Electrical Characteristics</b>	<b>7</b>
<b>9. Block Functional Descriptions</b>	<b>11</b>
<b>10. Loop filter /Charge Pump</b>	<b>12</b>
<b>11. Register Map</b>	<b>13</b>
<b>12. Lock Detect</b>	<b>22</b>
<b>13. Frequency Setup</b>	<b>25</b>
<b>14. Fast Lock mode</b>	<b>26</b>
<b>15. VCO</b>	<b>27</b>
<b>16. Power up Sequence</b>	<b>28</b>
<b>17. Typical Evaluation Board Schematic</b>	<b>29</b>
<b>18. Interface Circuit</b>	<b>31</b>
<b>19. Outer Dimensions</b>	<b>33</b>
<b>20. Marking</b>	<b>34</b>

**4. Block Diagram and Function**

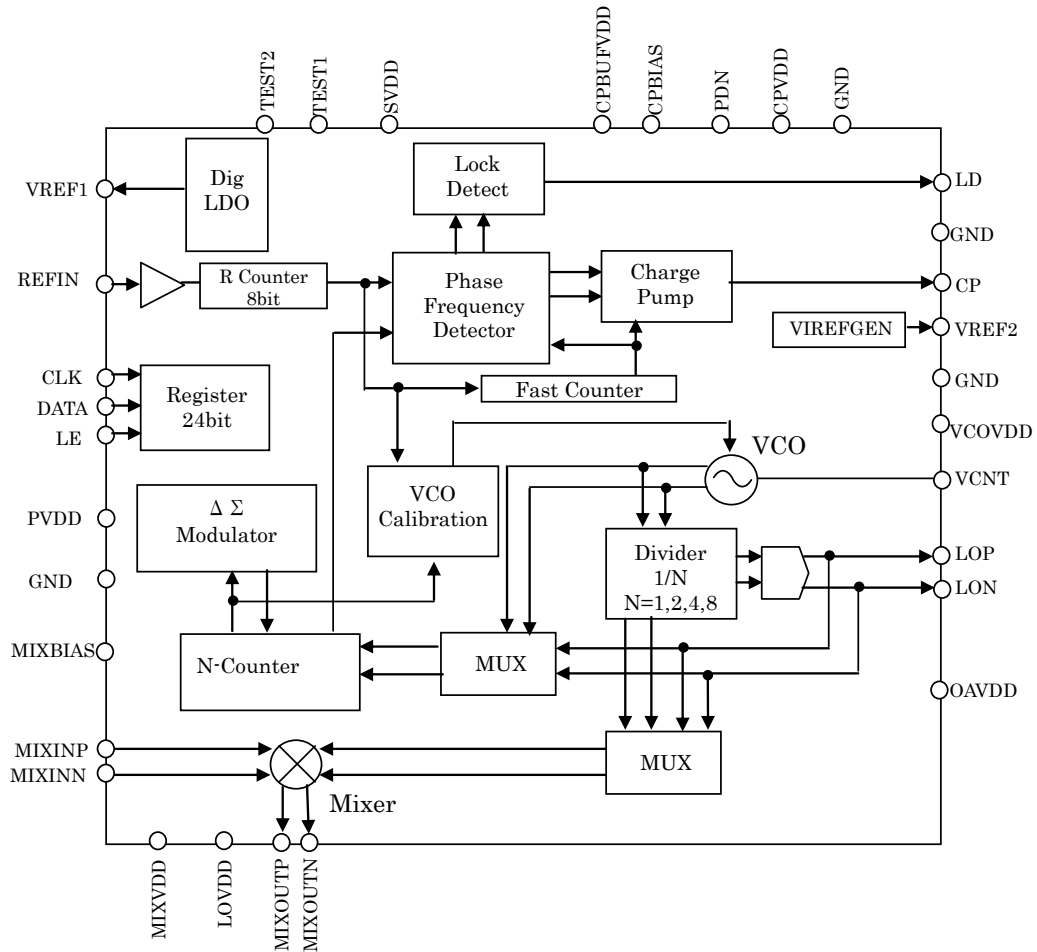

**Fig. 1 AK1572 Block diagram**

**Block function description**

Block	Function
Mixer	Frequency Mixer which converts RF signal to IF signal
N divider	Frequency divider which divides the signal of VCO and pass it to phase frequency detector
ΔΣ Modulator	Control the modulus of N divider and realize fractional dividing
R counter	Frequency divider which divides the signal of reference clock and pass it to phase frequency detector
PFD (Phase Frequency Detector)	Detect a phase difference between the divided VCO signal and comparison frequency, and then drive the charge pump
Charge Pump	Output the electric charge according to the phase difference detected by PFD
VCO	The voltage controlled oscillator divided into three bands

<b>5. Pin function Description and Assignment</b>
---

**1. Pin Functions**

No	Name	I/O	Pin function	Power Down	Remarks
1	VREF1	AO	Connecting a capacitor to the ground plane		
2	PVDD	P	Synthesizer Power Supply		
3	GND	G			
4	MIXBIAS	AI	Connecting a resistor to the ground plane		
5	MIXINN	AI	Mixer Input		
6	MIXINP	AI	Mixer Complementary Input		
7	MIXVDD	P	Mixer Power Supply		
8	LOVDD	P	Mixer Local Power Supply		
9	MIXOUTP	AO	Mixer Output		Open collector
10	MIXOUTN	AO	Mixer Complementary Output		Open collector
11	PDN	DI	Power Control A logic low on this pin powers down the device		Schmidt trigger input
12	LE	DI	Load Enable		Schmidt trigger input
13	CLK	DI	Serial Clock Input		Schmidt trigger input
14	DATA	DI	Serial Data Input		Schmidt trigger input
15	LD	DO	Lock Detect Output	LOW	
16	SVDD	P	Interface Power Supply		
17	LOP	AIO	Local complementary Input / Output		
18	LON	AIO	Local Input / Output		
19	OAVDD	P	Local Output Amplifier Power Supply		
20	GND	G			
21	VCNT	AI	Control Input to VCO		
22	VREF2	AO	Connecting a capacitor to the ground plane		
23	GND	G			
24	VCOVDD	P	VCO Power Supply		
25	CPBIAS	AI	Connecting a resistor to the ground plane		
26	CP	AO	Charge Pump Output	Tri-State	
27	GND	G			
28	CPVDD	P	Charge Pump Power Supply		
29	CPBUFVDD	P	Charge Pump Pre-Buffer Power Supply		

No	Name	I/O	Pin function	Power Down	Remarks
30	TEST1	DI	Test enable A logic low on this pin test mode the device.		Pull Down Schmidt trigger input
31	TEST2	DI	Test enable A logic low on this pin test mode the device.		Pull Down Schmidt trigger input
32	REFIN	AI	Reference Input		

Note 1) The exposed pad at the center of the backside should be connected to ground.

The following table shows the meaning of abbreviations used in the “I/O” column above.

AI:Analog input pin	AO:Analog output pin	AIO:Analog I/O pin	DI:Digital input pin
DO:Digital output pin	P: Power supply pin	G:Ground pin	

## 2. Pin Assignments

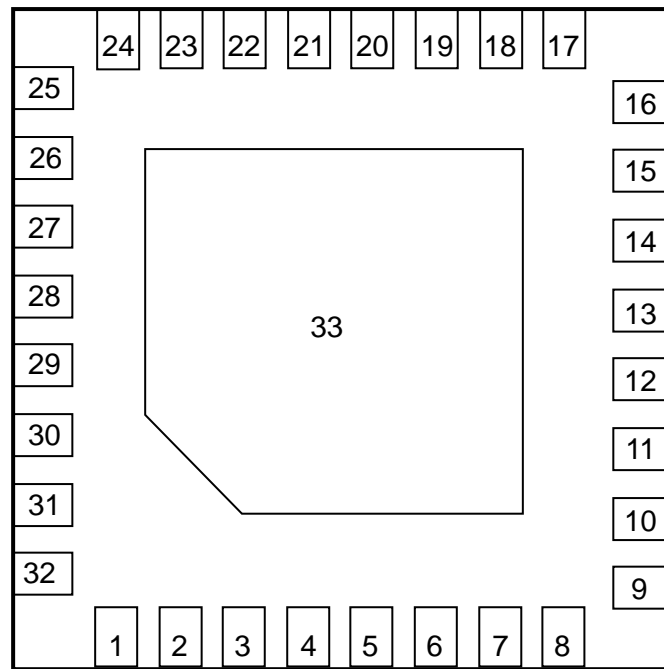

32pin QFN (0.5mm pitch, 5mm x 5mm)

Fig. 2 Package Pin Layout (Top View)

<b>6. Absolute Maximum Rating</b>
-----------------------------------

Parameter	Symbol	Min.	Max.	Unit	Remarks
Supply Voltage	VDD1	-0.3	5.5	V	Note1, Note2
	VDD2	-0.3	5.5	V	Note 3
	VDD3	-0.3	5.5	V	Note4
Ground Level	VSS	0	0	V	Note5
Maximum RF Input Level	RFPOW		12	dBm	Note6
Maximum Lo Input Level	LOPOW		12	dBm	Note7
Analog Input Voltage	VAIN	VSS-0.3	VDD3+0.3	V	Note1, Note8
Digital Input Voltage1	VDIN1	VSS-0.3	VDD1+0.3	V	Note1, Note9
Digital Input Voltage 2	VDIN2	VSS-0.3	VDD3+0.3	V	Note1, Note10
Input Current	IIN	-10	10	mA	
Storage Temperature	Tstg	-55	125	°C	

Note1 All voltage reference ground level: 0V

Note2 Applied to the [SVDD] pin

Note3 Applied to the [MIXVDD] and [LOVDD] pins

Note4 Applied to the [CPVDD], [CPBUFVDD], [PVDD], [VCOVDD] and [OAVDD] pins

Note5 Applied to the All [GND] pins

Note6 Applied to the [MIXINP] and [MIXINN] pins

Note7 Applied to the [LOP] and [LON] pins

Note8 Applied to the [VCNT] and [REFIN] pins

Note9 Applied to the [CLK], [DATA], [LE] and [PDN] pins

Note10 Applied to the [TEST1] and [TEST2] pins

Exceeding these maximum ratings may result in damage to the AK1572. Normal operation is not guaranteed at these extremes.

## 7. Recommended Operating Range

Parameter	Symbol	Min.	Typ.	Max.	Unit	Remarks
Operating Temperature	Ta	-40		85	°C	
Supply Voltage	VDD1	2.7	3.0	5.25	V	
	VDD2	4.75	5	5.25	V	
	VDD3	2.7	3	3.6	V	
		4.75	5	5.25	V	

Note1 Applied to the [SVDD] pin

Note2 Applied to the [MIXVDD] and [LOVDD] pins

Note3 Applied to the [CPVDD], [CPBUFVDD], [PVDD], [VCOVDD] and [OAVDD] pins

## 8. Electrical Characteristics

### 1. Digital DC Characteristics

Parameter	Symbol	Conditions	Min.	Typ.	Max.	Unit	Remarks
High level input voltage	Vih		0.8×VDD1			V	Note 1)
Low level input voltage	Vil				0.2×VDD1	V	Note 1)
High level input current 1	Iih1	Vih = VDD1=5.25V	-1		1	μA	Note 1)
High level input current 2	Iih2	Vih = VDD2=5.25V	27	53	106	μA	Note 2)
Low level input current	Iil	Vil = 0V, VDD1=5.25V	-1		1	μA	Note 1)
High level output voltage	Voh	Ioh = -500μA	VDD1-0.4			V	Note 3)
Low level output voltage	Vol	Iol = 500μA			0.4	V	Note 3)

Note1 Applied to the [CLK], [DATA], [LE], and [PDN] pins

Note2 Applied to the [TEST1] and [TEST2] pins

Note3 Applied to the [LD] pin

2. Serial Interface Timing

<Write-In Timing>

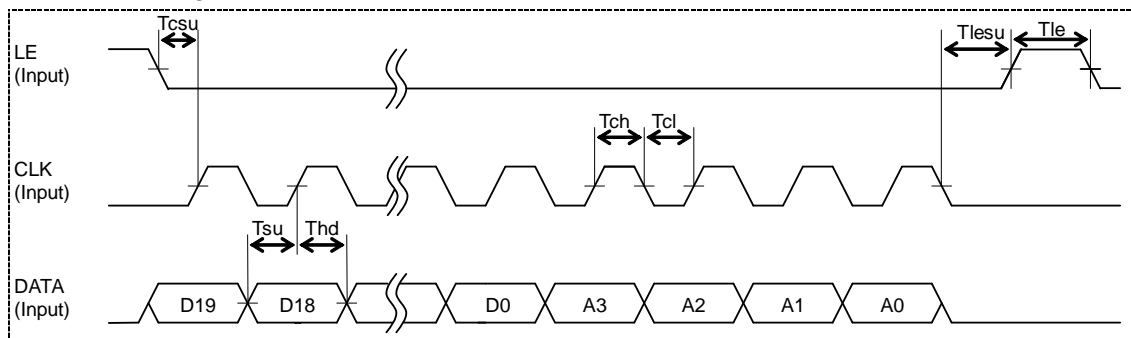

Fig.3 Serial Interface Timing

Serial Interface Timing

Parameter	Symbol	Min.	Typ.	Max.	Unit	Remarks
Clock L level hold time	Tcl	25			ns	
Clock H level hold time	Tch	25			ns	
Clock setup time	Tcsu	10			ns	
Data setup time	Tsu	10			ns	
Data hold time	Thd	10			ns	
LE setup time	Tlesu	10			ns	
LE pulse width	Tle	25			ns	



### 3. Analog Circuit Characteristics

VDD1=2.7~5.25V, VDD2=4.75~5.25V, VDD3=2.7~3.6V or 4.75~5.25V,  $-40^{\circ}\text{C} < \text{Ta} < 85^{\circ}\text{C}$ ,  
 CPBIAS=27k $\Omega$ , MIXBIAS=33k $\Omega$ , IF output frequency=200MHz, Internal VCO using  
 unless otherwise specified.

Item	Min.	Typ.	Max.	Unit	Remark
RF Frequency Range	690		4000	MHz	
IF Frequency Range	20		500	MHz	
Internal LO Frequency Range	262.5		4400	MHz	
LO Input Level	-5	0	+5	dBm	{MODE}=2,differential input or {MODE}=3
LO Input Level 2	-5		+1	dBm	{MODE}=2, single input
LO Output Level @1GHz		6		dBm	{LOLV}=3
		3		dBm	{LOLV}=2
		0		dBm	{LOLV}=1
		-6		dBm	{LOLV}=0
<b>Mixer</b>					
Mixer Input impedance		50		$\Omega$	with matching circuit
Mixer Output impedance		200		$\Omega$	with matching circuit
Current Adjusting resistance	22	33	56	k $\Omega$	Connect to [MIXBIAS] pin
RFIN=2GHz					
Conversion Gain	-4.5	-1.5	1.5	dB	
Half IF response		-60		dBc	Pin=-5dBm
RF P1dB	7	10		dBm	
IIP3	20	23		dBm	guaranteed by design
NF		14	17	dB	guaranteed by design
Local Leakage LO-to-RF		-60		dBm	Use internal VCO
		-55		dBc	Use external Local
Local Leakage LO-to-IF		-80		dBm	Use internal VCO
		-70		dBc	Use external Local
RFIN=1GHz					
NF		12		dB	
RFIN=4GHz					
NF		18		dB	

Item	Min.	Typ.	Max.	Unit	Remark
<b>REFIN characteristics</b>					
Input Sensitivity	0.4		2	V <sub>pp</sub>	
Input Frequency	10		300	MHz	
<b>Phase Frequency Detector</b>					
PFD frequency	1.2		40	MHz	
<b>Charge Pump</b>					
CP Maximum current		2400		μA	
CP Minimum current		300		μA	
I <sub>cp</sub> TRI-STATE leak current		1		nA	T <sub>a</sub> =25°C
CP Output Range	0.5		VDD3 -0.5	V	
CP current adjusting resistance	22	27	33	kΩ	Connect to [CPBIAS] pin
Normalized Phase Noise		-218		dBc/Hz	
<b>VCO</b>					
Operating Frequency Range	2100		3000	MHz	VCO1
	3000		3400	MHz	VCO2
	3400		4400	MHz	VCO3
VCO sensitivity		f <sub>v</sub> × 0.02		MHz/V	f <sub>v</sub> : Oscillation Frequency
Phase Noise @2.1GHz	10kHz offset		-85	dBc/Hz	
	100kHz offset		-111	dBc/Hz	
	1MHz offset		-132	dBc/Hz	
	10MHz offset		-152	dBc/Hz	

Item	Min.	Typ.	Max.	Unit	Remark
<b>Current Consumption</b>					
IDD1		1	2	mA	[PDN]='L'
IDD2		140	200	mA	[PDN]='H', {MIXEN}=1, {MODE}=0, {DIV}=0
IDD3		150	210	mA	[PDN]='H', {MIXEN}=1, {MODE}=0, {DIV}≥2
IDD4		190	270	mA	[PDN]='H', {MIXEN}=1, {MODE}=1, {DIV}≥2

## 9. Block Functional Descriptions

### • Operation Mode

AK1572 operation is controlled as follows by the [PDN] pin and registers.

Function	Pin	Registers			Operating state			
	[PDN]	{MIXEN}	MODE[1]	MODE[2]	Mixer	Synthesizer	VCO	Local Out
StandBy1	"L"	X	X	X	OFF	OFF	OFF	OFF
Prohibited	"H"	0	0	0	OFF	ON	ON	OFF
Func1	"H"	0	0	1	OFF	ON	ON	Output
Func2	"H"	0	1	0	OFF	ON	OFF	Input
StandBy2	"H"	0	1	1	OFF	OFF	OFF	OFF
Func3	"H"	1	0	0	ON	ON	ON	OFF
Func4	"H"	1	0	1	ON	ON	ON	Output
Func5	"H"	1	1	0	ON	ON	OFF	Input
Func6	"H"	1	1	1	ON	OFF	OFF	Input

StandBy1: Stand-by mode. Current consumption is minimized. It is available to write to the registers.

Func1: VCO and Synthesizer are active and Local signal outputs from [LOP] and [LON] pins.

Func2: Only Synthesizer is active. PLL operation is available with the external VCO.

StandBy2: Stand-by mode. Current consumption is minimized. It is available to write to the registers.

Func3: VCO, Synthesizer and Mixer are active.

Func4: VCO, Synthesizer and Mixer are active and Local signal outputs from [LOP] and [LON] pins.

Func5: Synthesizer and Mixer are active. PLL operation is available with the external VCO.

Func6: Only Mixer is active. A local signal needs to be input from [LOP] and [LON] pins.

10. Loop filter /Charge Pump

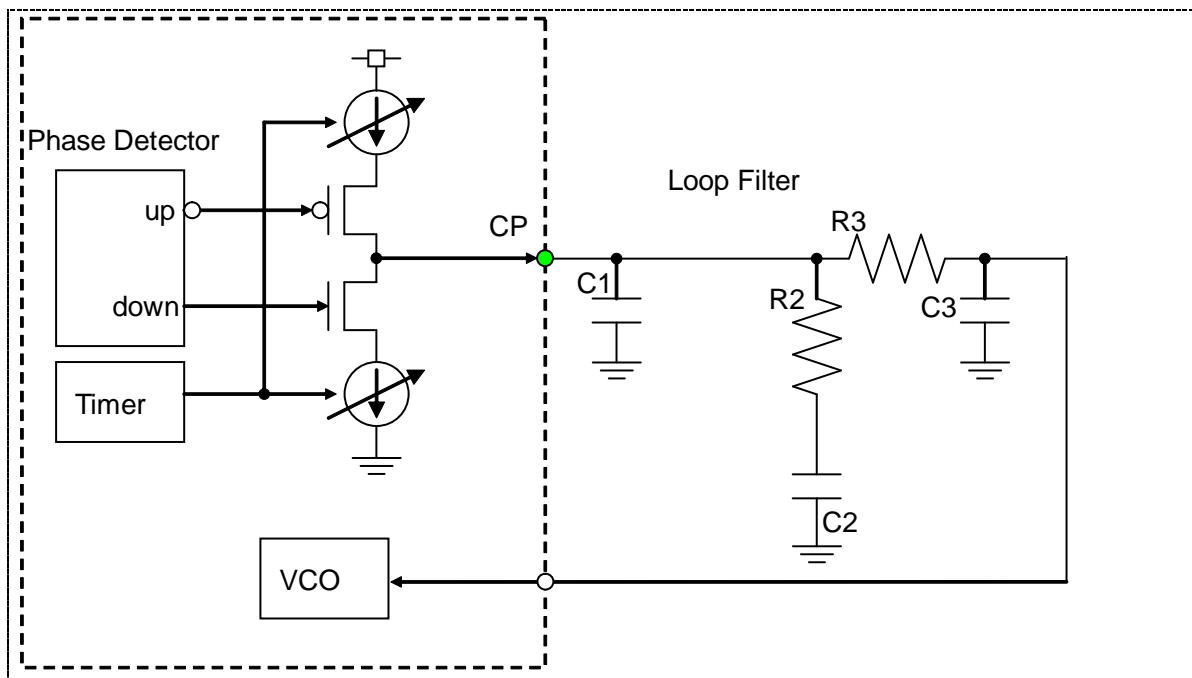

Fig.4 Loop Filter Schematic

**11. Register Map**

Name	Data	Address			
Freq1	D19 - D0	0	0	0	1
Freq2		0	0	1	0
Freq3		0	0	1	1
Function		0	1	0	0

Name	D19	D18	D17	D16	D15	D14	D13	D12	D11	D10	D9	D8	D7	D6	D5	D4	D3	D2	D1	D0	Address
Freq1	0	0	0	VCO [1]	VCO [0]	DIV [1]	DIV [0]	0	INT [11]	INT [10]	INT [9]	INT [8]	INT [7]	INT [6]	INT [5]	INT [4]	INT [3]	INT [2]	INT [1]	INT [0]	0x01
Freq2	0	CP1 [2]	CP1 [1]	CP1 [0]	0	CP2 [2]	CP2 [1]	CP2 [0]	FRAC [11]	FRAC [10]	FRAC [9]	FRAC [8]	FRAC [7]	FRAC [6]	FRAC [5]	FRAC [4]	FRAC [3]	FRAC [2]	FRAC [1]	FRAC [0]	0x02
Freq3	R [7]	R [6]	R [5]	R [4]	R [3]	R [2]	R [1]	R [0]	MOD [11]	MOD [10]	MOD [9]	MOD [8]	MOD [7]	MOD [6]	MOD [5]	MOD [4]	MOD [3]	MOD [2]	MOD [1]	MOD [0]	0x03
Function	CALTM [3]	CALTM [2]	CALTM [1]	CALTM [0]	0	LDCNT SEL	LD	MTLD	FAST EN	FAST [3]	FAST [2]	FAST [1]	FAST [0]	CP HIZ	DSM ON	MIX EN	MODE [1]	MODE [0]	LOLV [1]	LOLV [0]	0x04

**Notes for writing into registers**

- 1) The setting of <Address 0x02> and <Address 0x03> is reflected to each circuit when writing to <Address 0x01>.
- 2) <Address 0x04> behavior is reflected by itself.

When AK1572 powers on, the initial registers value is not defined. It is required to write the data in all addresses in order to commit it.

## &lt; Address0x01:Freq1 &gt;

**D [16:15]****VCO[1:0] : Select VCO**

In accordance with the used frequency, select the VCO.

VCO[1:0] Dec	VCO oscillating range Frequency
0	2.1GHz~3.0GHz
1	3.0GHz~3.4GHz
2	3.4GHz~.4GHZ
3	prohibited

**D [14:13]****DIV[1:0] : LoDivider**

In accordance with the used frequency, select the division number.

DIV[1:0] Dec	LoDivider Divide Number
0	No divide
1	2 divide
2	4 divide
3	8 divide

**D [11:0]****INT[11:0] : NDivider**

N divider divided number.

The allowed range is 35 to 4091.

## &lt; Address0x02:Freq2 &gt;

**D [18:16]****CP1[2:0] : Set the charge pump current for normal status****D [14:12]****CP2[2:0] : Set the charge pump current for fast lock**

CP1 is the charge pump current setting of the normal mode.

CP2 is the charge pump current setting of the fast lock mode

Charge pump current is determined by the following formula.

Charge pump current [A] =  $I_{cp\_min}$  [A] × (CP1 or CP2 setting value+1) $I_{cp\_min}$  [A] = 8.1 / R [ohm]

R: the resistance value which is connected to [CPBIAS] pin

Charge pump current (typ) unit :  $\mu$ A

CP1[2:0] CP2[2:0]	R		
	33k $\Omega$	27k $\Omega$	22k $\Omega$
0	245	300	368
1	491	600	736
2	736	900	1105
3	982	1200	1473
4	1227	1500	1841
5	1473	1800	2209
6	1718	2100	2577
7	1964	2400	2945

**D [11:0]****FRAC[11:0]: Fractional Numerator determination**

Set the Numerator of Fractional divider.

The allowed range is from 0 to (MOD[11:0] -1).



## &lt; Address0x03:Freq3 &gt;

D[19:12]

R [7:0]: 8bit Reference Counter

Maximum PFD frequency is 40MHz

R[13:0]	Divide Ratio
0	Prohibited
1	1
2	2
3	3
4	4
•	•
•	•
•	•
253	253
254	254
255	255

D [11:0]

**MOD[11:0]: Fractional Denominator determination**

Set the denominator of Fractional divider.

The allowed range is from 2 to 4095.

**< Address0x04: function >**

**D[19:16]**

**CALTM [3:0]: Set the calibration precision of VCO**

The register {CALTM [3:0]} determines the calibration precision and time for VCO. When {CALTM [3:0]} is larger, the calibration precision increases, but the required time becomes long as trade-off. The value calculated by the following formula is recommended to get enough calibration precision. However, {CALTM [3:0]} should be set between from 1 to 11. 0 and over 11 is prohibited.

$$\{CALTM[3:0]\} \geq \log_2(F_{PFD}/20000)$$

$F_{PFD}$  : PFD frequency

The calibration time can be estimated as following calculation;

$$\text{Calibration time} = 1 / F_{PFD} \times \{(6 + 2^{\{CALTM[3:0]\}}) \times 8 + 3\}$$

**D [14]**

**LDCNTSEL: Lock Detect Precision**

Set the counter value for digital lock detect.

LDCNTSEL	Function	
0	15 times Count	unlocked to locked
	3 times Count	locked to unlocked
1	31 times Count	unlocked to locked
	7 times Count	locked to unlocked

**D [13]**

**LD: Lock detect function**

Set the lock detect function.

- 0: Digital lock detect
- 1: Analog lock detect

**D [12]**

**MTLD: Local signal mute**

- 0: Don't mute local signal in unlock state.
- 1: Mute local signal in unlock state.

※Please use {MTLD} =0 at the time of {LD}=1.

**D [11]****FASTEN : Fast Lock mode setting**

Enable / disable fast lock mode.

0: Disable fast lock mode

1: Enable fast lock mode

Please refer to "14. Fast lock mode" for details.

**D[10:7]****FAST [3:0] : Fast lock timer setting**

Set the count number of fast lock timer.

Count Number = 511 + FAST[3:0] × 512

TIMER[3:0]	Count Number
0	511
1	1023
2	1535
3	2047
4	2559
5	3071
6	3583
7	4095
8	4607
9	5119
10	5631
11	6143
12	6655
13	7167
14	7679
15	8191

**D [6]****CPHIZ: Charge Pump TRI-STATE**

Set the charge pump output in Tri-State.

0: Normal

1: Tri-State

**D [5]****DSMON:**  $\Delta\Sigma$ -modulator activationIn Integer-N setting, set the  $\Delta\Sigma$ -modulator to active.0:  $\Delta\Sigma$ -modulator inactive1:  $\Delta\Sigma$ -modulator active**D [4]****MIXEN:** Mixer Enable

0: Stand-by

1: Enable

**D [3:2]****MODE [1:0]: Local operation mode**

Set the operation of Synthesizer, VCO and LOP/LON pins.

<b>MODE[1:0]</b>	<b>Local Operating MODE</b>
0	Internal Synthesizer and VCO are active.
1	Internal Synthesizer and VCO are active and the local signal outputs from LOP/LON pins.
2	The mode operating external VCO with internal synthesizer.
3	The mode using an external local signal.

**D [1:0]****LOLV [1:0]: Local output power**

At the state of {MODE [1:0]} =1, set the power of the local signal output from LOP/LON pins.

<b>LOLV[1:0]</b>	<b>LOP, LON output power [dBm]</b>
0	-6
1	0
2	3
3	6

**12. Lock Detect**

Lock detect output can be selected by {LD} in D [13] of <Address0x04>. When {LD} is set to “1”, the [LD] pin outputs a phase comparison result which is from phase detector directly. (This is called “analog lock detect”.) When {LD} is set to “0”, the output is the lock detect signal according to the on-chip logic. (This is called “digital lock detect”.)

The digital lock detect can be done as following:

The [LD] pin is in unlocked state (which outputs “L”) when a frequency setup is made.

In the digital lock detect, the [LD] pin outputs “H” (which means the locked state) when a phase error smaller than a cycle of [REFIN] clock (T) is detected for N times consecutively. When a phase error larger than T is detected for N times consecutively while the [LD] pin outputs “H”, then the [LD] pin outputs “L” (which means the unlocked state). The counter value N can be set by {LDCNTSEL} in D [14] of <Address0x04>. The N is different between “unlocked to locked” and “locked to unlocked”.

{LDCNTSEL}	unlocked to locked	locked to unlocked
0	N=15	N=3
1	N=31	N=7

The lock detect signal is shown below

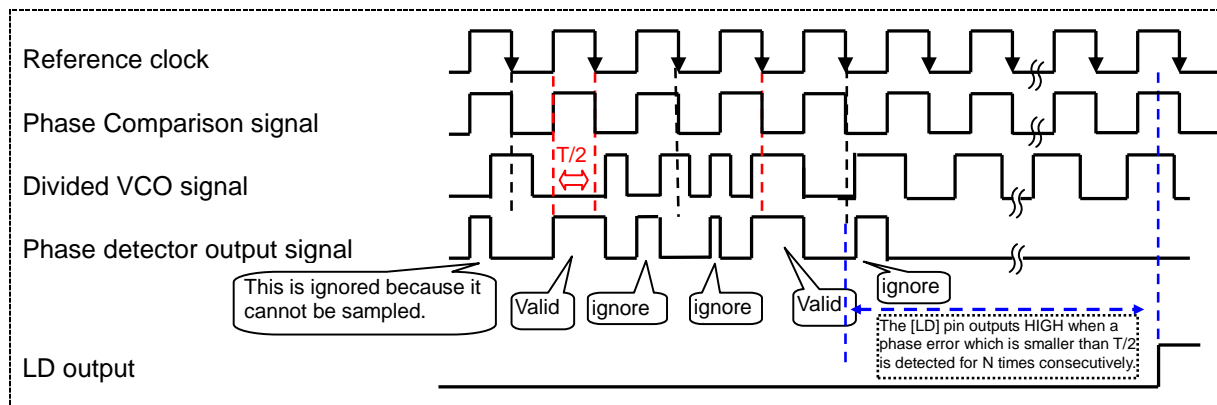

Case of "R = 1"

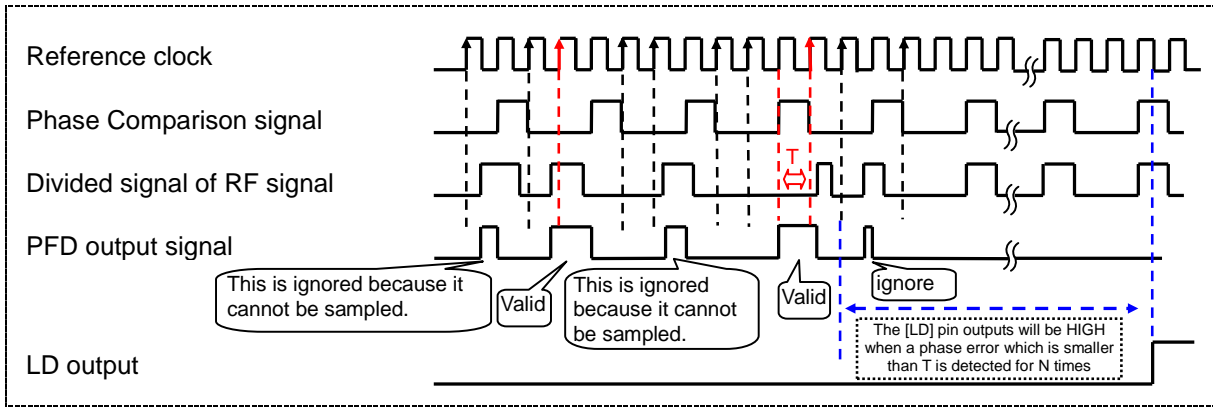

Case of "R > 1"

**Fig6. .Digital Lock Detect Operations**

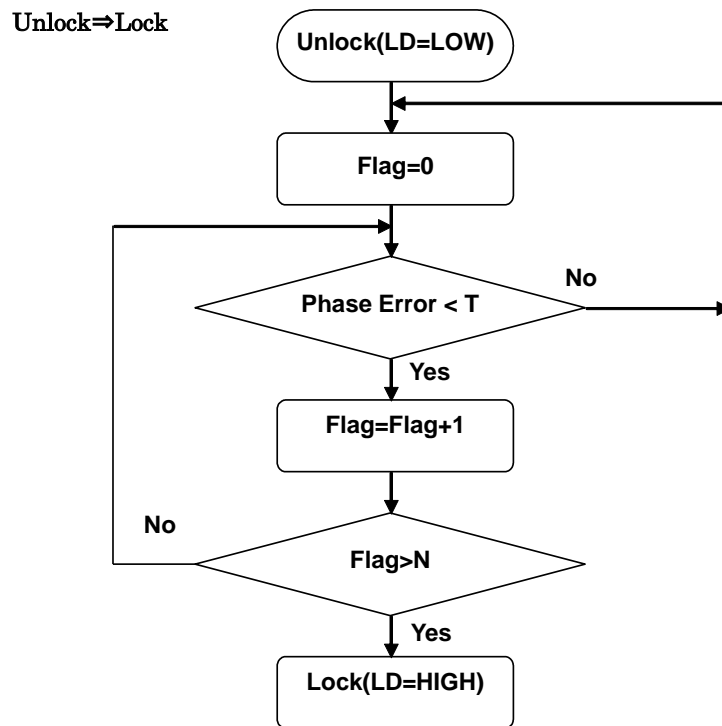

Lock⇒unlock

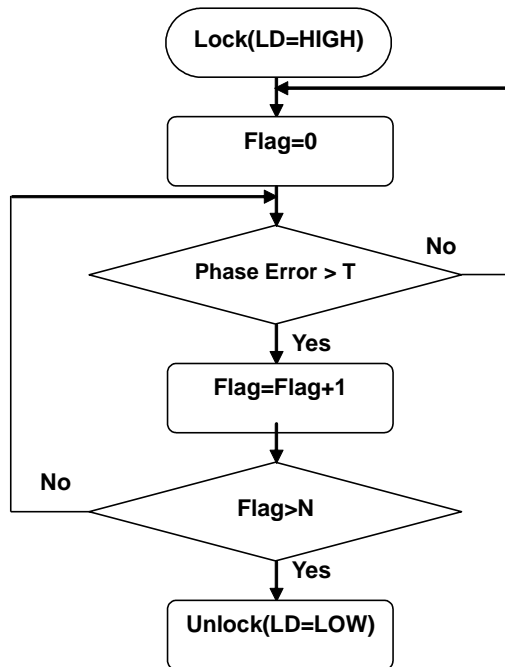



### 13. Frequency Setup

The following formula is used to calculate the frequency setting for the AK1572.

$$\text{Frequency setting} = \text{Ref Frequency} \times (\text{INT} + \text{FRAC}/\text{MOD})$$

Ref Frequency	: PFD frequency
INT	: Integer divide Number (Refer to <Address 0x01>: INT[11:0])
FRAC	: Numenator setting number (Refer to <Address 0x02>: FRAC[11:0])
MOD	: Denominator setting number (Refer to <Address 0x03>: MOD[11:0])

Set in the range of 35 to 4091 for INT[11:0].

Set in the range of 0 to (MOD-1) for FRAC[11:0]

Set in the range of 2 to 4095 for MOD[11:0]

#### ○ Example

To complete Ref Frequency=19.2MHz, Frequency setting=2460.1MHz, set as follows

INT	=	128
FRAC	=	25
MOD	=	192

$$\text{Frequency setting} = 19.2\text{MHz} \times (128 + (25 / 192)) = 2460.1\text{MHz}$$

By writing <Address 0x01, 0x02, 0x03>, frequency is set. When <Address 0x01> is written, the setting of <Address 0x03> and <Addresses 0x02> is reflected in the internal circuit. At the time of the writing of <Address 0x01>, it is necessary for a synthesizer block to be powered on. The writing of <Address 0x01> as a trigger, frequency setting and VCO calibration are carried out, and fast lock counter starts operation. To set frequency definitely, <Address 0x01> should be written in the state that {MODE [1:0]} in <Address 0x04> is 0 or 1 or 2 and [PDN] pin is "H".

**14. Fast Lock mode**

The fast lock mode becomes effective when set {FASTEN} of <Address 0x04> to "1".

○Fast Lock Mode

When writing in <Address0x01> with {FASTEN}=1, Fast Lock Up mode starts after calibration. The Fast Lock Up mode is valid only during the time period set by the timer according to the counter value in {FAST [3:0]} in <Address0x04>, and the charge pump current is set to the value specified by {CP2}. When the specified time period elapses, the Fast Lock Up mode operation is switched to the normal operation, and the charge pump current returns to {CP1} setting

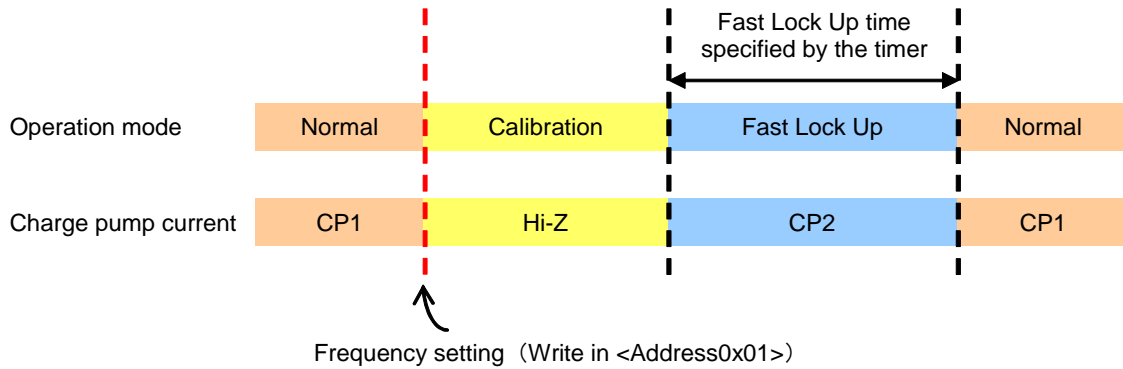

Fig.7. Fast Lock up Mode Timing Chart

○Timer period

{FAST [3:0]} in <Address0x04> is used to set the time period for this mode. The following formula is used to calculate the time period

$$\text{Counter Value} = 511 + \text{FAST}[3:0] \times 512$$

## 15. VCO

### Calibration

AK1572 has three VCO core in uses several overlapping bands to allow low Phase Noise, low VCO sensitivity ( $K_{VCO}$ ) and wide frequency range. The selection which VCO should be used can be done by the register {VCO[1:0]} in <Address 0x01>. Moreover, the correct band is chosen automatically at frequency setting, which is called calibration.

The calibration starts when <Address0x01> are written in the condition that {MODE[1]} in <Address 0x04>="0" and [PDN] pin="H". During the calibration,  $V_{TUNE}$  of VCO is disconnected from the output of the loop filter and connected to an internal reference voltage. The charge pump output is disabled.

The internal bias must be stable so that the calibration is done correctly. Therefore, it is necessary to wait 500 $\mu$ sec at least until <Address0x01> writing after [PDN] rises up.

The register {CALTM [3:0]} determines the calibration time. When {CALTM [3:0]} is larger, the calibration precision increases, but the required time becomes long as a trade-off. The value calculated by the following formula is recommended to get enough calibration precision. However, {CALTM [3:0]} should be set at from 1 to 11. 0 and over 11 is prohibited.

$$\{\text{CALTM}[3:0]\} \geq \log_2(F_{\text{PFD}} / 20000)$$

$F_{\text{PFD}}$  : PFD frequency

The calibration time can be estimated as following calculation;

$$\text{Calibration time} = 1 / F_{\text{PFD}} \times \{(6 + 2^{\{\text{CALTM} [3:0]\}}) \times 8 + 3\}$$

**16. Power up Sequence**

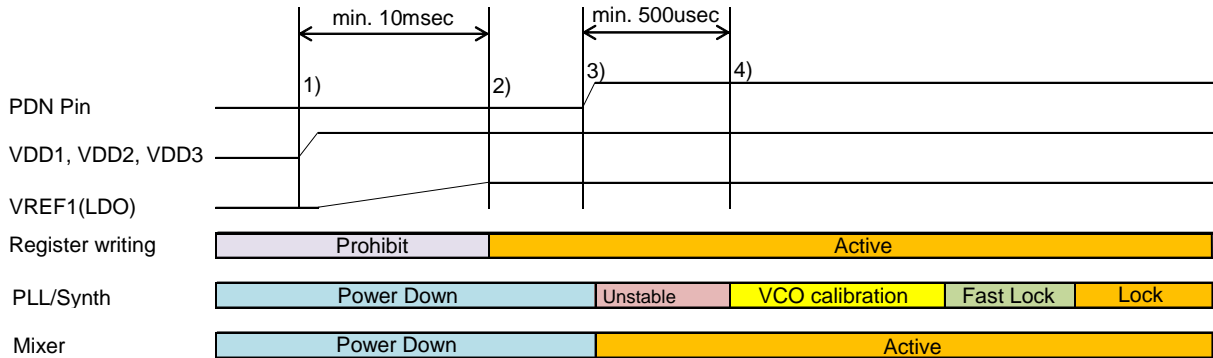

- 1) Set [PDN] pin to “L” and turn on power supplies (VDD1/VDD2/VDD3)
- 2) The stabilization time for [VREF1] (LDO) is 10msec. After LDO is stabilized, write the data to the registers of <Address 0x01, 0x02, 0x03, 0x04>
- 3) Set [PDN] pin to “H”. In this state, the internal circuits are in an operating state, but PLL/Synth is unstable yet.
- 4) The stabilization time of internal BIAS circuits is 500usec. After BIAS circuit is stabilized, write the data to <Address 0x01>. VCO calibration starts and PLL status will be locked. Refer to 14.Fast Lock Mode and 15.VCO contents regarding fast Lock mode and VCO calibration.

Note1) The initial register values are not defined. Therefore, it is required to write the data in all addresses of the register.

Note2) The stabilization time for LDO is required more than 10ms.

## 17. Typical Evaluation Board Schematic

1. Evaluation Board schematic and the list of external parts

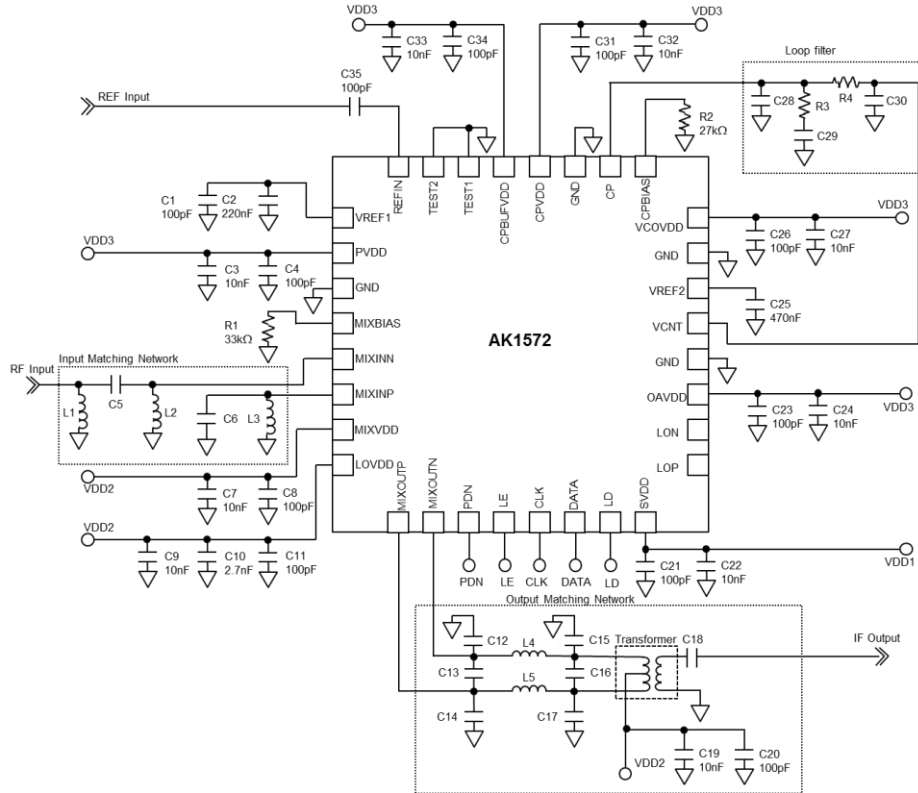

**Fig.9. Typical Evaluation Board Schematic**

Ref.	Value	Ref.	Value	Ref.	Value	Ref.	Value	Ref.	Value
C1	100pF	C10	2.7nF	C19	10nF	C28	Loop Filter	L2	Matching
C2	220nF	C11	100pF	C20	100pF	C29	Loop Filter	L3	Matching
C3	10nF	C12	Matching	C21	100pF	C30	Loop Filter	L4	Matching
C4	100pF	C13	Matching	C22	10nF	C31	100pF	L5	Matching
C5	Matching	C14	Matching	C23	100pF	C32	10nF	R1	33kΩ
C6	Matching	C15	Matching	C24	10nF	C33	10nF	R2	27kΩ
C7	10nF	C16	Matching	C25	470nF	C34	100pF	R3	Loop Filter
C8	100pF	C17	Matching	C26	100pF	C35	100pF	R4	Loop Filter
C9	10nF	C18	Matching	C27	10nF	L1	Matching		

Note1) Exposed Pad at the center of the backside is should be connected to ground.

Note2) [TEST1] and [TEST2] pins should be connected to ground.

2. External circuit to input the external Local signal to [LOP] and [LON] pins.

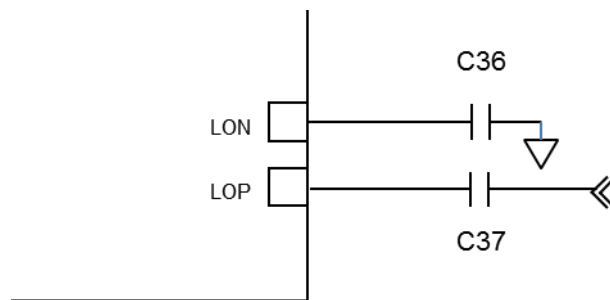

**Fig 7 Circuit for local input**

Ref	Value
C36	100pF
C37	100nF

3. External circuit to output the internal local signal from [LOP] and [LON] pins

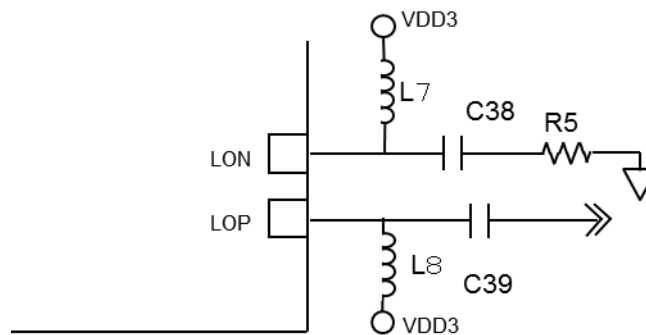
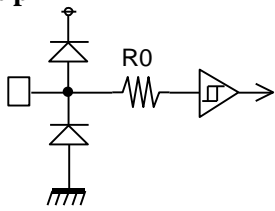
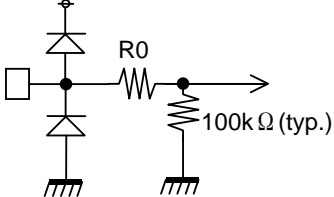
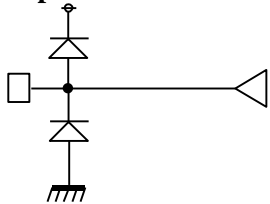
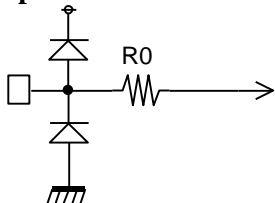

**Fig 8 Circuit for local output**

Example of the external components for this mode

Ref	Value
C38	100pF
C39	100pF
L7	180nH
L8	180nH
R5	50Ω

**18. Interface Circuit**

Pin No.	Name	I/O	R0(Ω) (typ.)	Cur(μA)	Function
11	PDN	DI	300		<b>Digital input pin</b> 
12	LE	DI	300		
13	CLK	DI	300		
14	DATA	DI	300		
30	TEST1	DI	300		<b>Digital input pin Pull-Down</b> 
31	TEST2	DI	300		
15	LD	DO			<b>Digital Output pin</b> 
21	VCNT	I	100		<b>Analog input pin</b> 
32	REFIN	I	300		

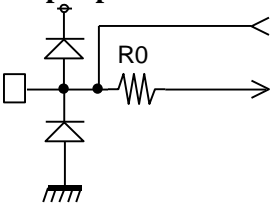
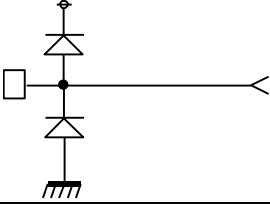
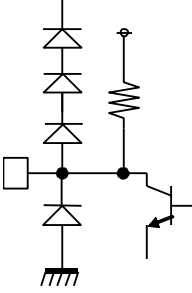
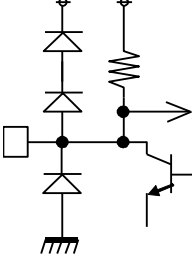
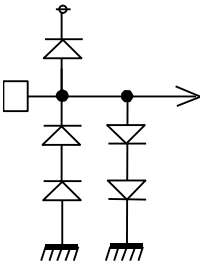
Pin No.	Name	I/O	R0(Ω) (typ.)	Cur(μA)	Function
1	VREF1	AO	300		<b>Analog input/output pin</b> 
4	MIXBIAS	AO	300		
22	VREF2	AI	300		
25	CPBIAS	AI	300		
23	CP	O			<b>Analog output pin</b> 
9	MIXOUTN	O			<b>RF open collector output pin</b> 
10	MIXOUTP	O			
17	LOP	IO			<b>RF open collector input/output pin</b> 
18	LON	IO			
5	MIXINN	IO			<b>RF input pin</b> 
6	MIXINP	IO			



**19. Outer Dimensions**

QFN32-5X5-0.50

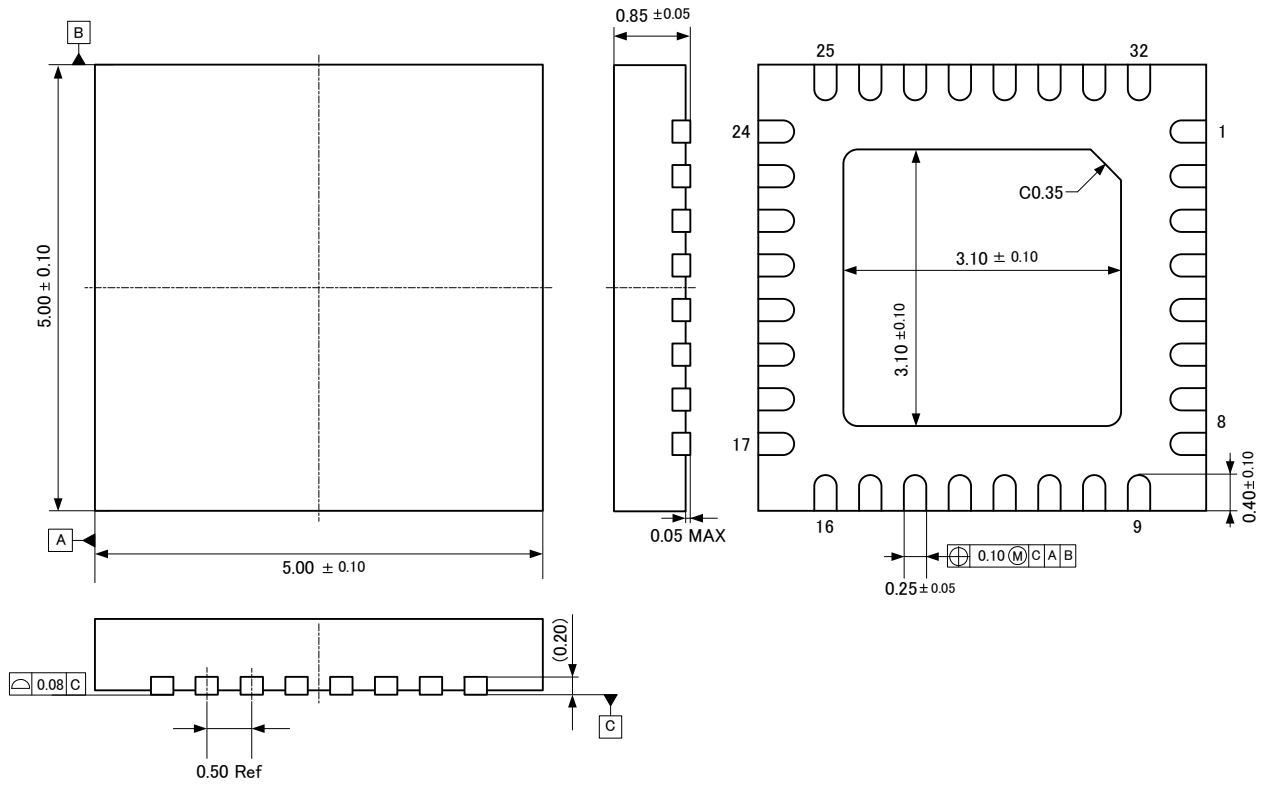

Note) The exposed pad at the center of the backside should be connected to ground.

**20. Marking**

(a) Style : QFN

(b) Number of pins : 32

(c) 1 pin marking: ○

(d) Product number : 1572

(e) Date code : YWWL (4 digits)

Y: Lower 1 digit of calendar year (Year 2013 → 3, 2014 → 4 ...)

WW: Week

L: Lot identification, given to each product lot which is made in a week  
→ LOT ID is given in alphabetical order (A, B, C...).

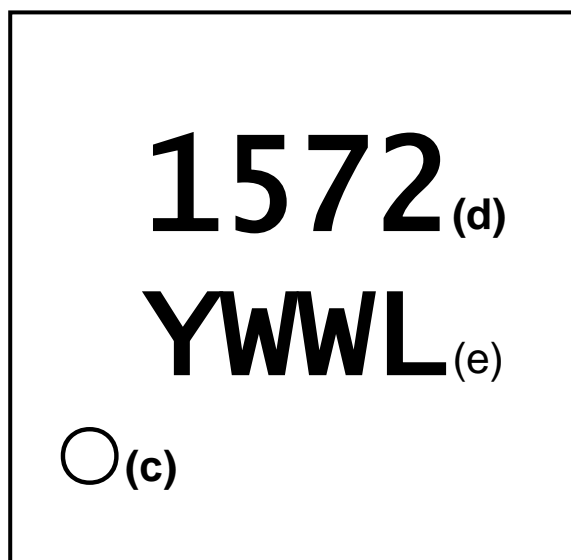

## IMPORTANT NOTICE

0. Asahi Kasei Microdevices Corporation (“AKM”) reserves the right to make changes to the information contained in this document without notice. When you consider any use or application of AKM product stipulated in this document (“Product”), please make inquiries the sales office of AKM or authorized distributors as to current status of the Products.
1. All information included in this document are provided only to illustrate the operation and application examples of AKM Products. AKM neither makes warranties or representations with respect to the accuracy or completeness of the information contained in this document nor grants any license to any intellectual property rights or any other rights of AKM or any third party with respect to the information in this document. You are fully responsible for use of such information contained in this document in your product design or applications. **AKM ASSUMES NO LIABILITY FOR ANY LOSSES INCURRED BY YOU OR THIRD PARTIES ARISING FROM THE USE OF SUCH INFORMATION IN YOUR PRODUCT DESIGN OR APPLICATIONS.**
2. The Product is neither intended nor warranted for use in equipment or systems that require extraordinarily high levels of quality and/or reliability and/or a malfunction or failure of which may cause loss of human life, bodily injury, serious property damage or serious public impact, including but not limited to, equipment used in nuclear facilities, equipment used in the aerospace industry, medical equipment, equipment used for automobiles, trains, ships and other transportation, traffic signaling equipment, equipment used to control combustions or explosions, safety devices, elevators and escalators, devices related to electric power, and equipment used in finance-related fields. Do not use Product for the above use unless specifically agreed by AKM in writing.
3. Though AKM works continually to improve the Product’s quality and reliability, you are responsible for complying with safety standards and for providing adequate designs and safeguards for your hardware, software and systems which minimize risk and avoid situations in which a malfunction or failure of the Product could cause loss of human life, bodily injury or damage to property, including data loss or corruption.
4. Do not use or otherwise make available the Product or related technology or any information contained in this document for any military purposes, including without limitation, for the design, development, use, stockpiling or manufacturing of nuclear, chemical, or biological weapons or missile technology products (mass destruction weapons). When exporting the Products or related technology or any information contained in this document, you should comply with the applicable export control laws and regulations and follow the procedures required by such laws and regulations. The Products and related technology may not be used for or incorporated into any products or systems whose manufacture, use, or sale is prohibited under any applicable domestic or foreign laws or regulations.
5. Please contact AKM sales representative for details as to environmental matters such as the RoHS compatibility of the Product. Please use the Product in compliance with all applicable laws and regulations that regulate the inclusion or use of controlled substances, including without limitation, the EU RoHS Directive. AKM assumes no liability for damages or losses occurring as a result of noncompliance with applicable laws and regulations.
6. Resale of the Product with provisions different from the statement and/or technical features set forth in this document shall immediately void any warranty granted by AKM for the Product and shall not create or extend in any manner whatsoever, any liability of AKM.
7. This document may not be reproduced or duplicated, in any form, in whole or in part, without prior written consent of AKM.