

**AK2365****dPMR Filterless IF LSI**

1. Features

The AK2365 includes 2nd-Mixer, AGC+BPF, PLL FM detector, noise squelch, and RSSI circuit. This device can eliminate E to J type ceramic filters, quadrature discriminator, and other external components.

- Low operating voltage: VDD = 2.6 to 5.5 V
- Wide operating temperature: Ta = -40 to 85 °C
- High sensitivity: -102dBm at 12dB SINAD
- Built-in PGA and 2nd Mixer
- Local frequency: 45.9MHz, 50.4MHz, 57.6MHz (Triple of 15.3, 16.8 and 19.2MHz)
- Built-in programmable AGC+BPF circuits corresponding to E to J type ceramic filters
- Built-in PLL FM detector
- RSSI function
- Built-in noise squelch circuits
- Low consumption current: 6mA
- Compact plastic packaging: 32-pin QFNJ (4.0 x 4.0 x 0.75mm, 0.4mm pitch)

2. Contents

1. Features.....	1
2. Contents	2
3. Block Diagram	3
4. Circuit Configuration	4
5. Pin/Function.....	5
6. Absolute Maximum Ratings	7
7. Recommended Operating Conditions.....	7
8. Digital DC Characteristics	8
9. Digital AC Timing	9
10. Power-up Sequence	11
11. System Reset	11
12. Power Consumption.....	12
13. Analog Characteristics	13
14. Serial Interface Configuration	18
15. Calibration Procedure	24
16. AGC Operation	25
17. Recommended External Application Circuits	26
18. Packaging	30
19. Important Notice	31

4. Circuit Configuration

Block Description	
MIX	2nd-mixer to convert the input signal down to 450kHz.
AGC+BPF	The circuit composed of AGC and BPF, where the desired signal is amplified and spurious components included in the signal from the 2nd-mixer are eliminated.
IFBUF	The circuit to output filtered signal by AGC+BPF.
Divider	The circuit to divide the signal from LOIN pin.
Limiter	The circuit to amplify the signal filtered at the AGC+BPF stage and generate rectangular wave.
DISCRI	The demodulator circuit with PLL FM detector, where the audio signal is recovered.
LPF	The Low-pass filter to eliminate the noise generated at the DISCRI stage.
Noise AMP	The amplifiers to compose the Band-pass filter for noise squelch.
Noise Rectifier	The rectification circuit to detect the noise level.
Comparator	The circuit to compare the noise level with reference voltage level.
RSSI	The circuit to indicate the Received Signal Strength Indicator (RSSI) by generating a DC voltage corresponding to the input level from Limiter.
VIREF	The circuit to generate internal reference voltage.
LDO	The circuit to supply 2.7V power for some circuits.
Control Logic	The control register controls the status of internal condition by serial data that consists of 1 instruction bit, 6 address bits and 8 data bits.

5. Pin/Function

Package	Signal			Function	
	Pin No	Name	Type		Conditions at power down
	1	IFIP AI		Note 1)	IF signal input pin
	2	NC AIO		Z	NC pin
	3	NC AIO		Z	NC pin
	4	NC AIO		Z	NC pin
	5	NC AIO		Z	NC pin
	6	VREFA AO		Low	LDO re ference pin Connect the capacitor to stabilize LDO reference voltage.
	7	AVSS PWR		-	Analog VSS power supply pin
	8	AVDD PWR		-	Analog VDD power supply pin
	9	BIAS AO		Z	Output pin to connect bias resistor for reference voltage
	10	NRECTO AI		Note 2)	Output pin for the rectification circuit
	11	NAMPO AO		Z	Output pin for noise squelch amplifier
	12	NAMPI AI		Z	Input pin for noise squelch amplifier
	13	AUDIOOUT AO		Note 3)	Demodulated audio signal output pin
	14	DISCOUT AO		Note 4)	Pin2 for Discriminator Low-pass filter
	15	PDOUT AO		Z	Pin1 for Discriminator Low-pass filter
	16	RSSIOUT AO		Z	Output pin to connect capacitor for Received Signal Strength Indicator(RSSI)
	17	IFOUT AO		Note 5)	Output pin for IFBUF
	18	AVSS2 PWR		-	Analog VSS power supply pin
	19	PDN DI		Z	Power down pin for LDO
	20	RSTN DI		Z	Hardware reset pin
	21	CSN DI		Z	Chip select input pin for serial data
	22	SCLK DI		Z	Clock input pin for serial data
	23	SDATA DB		Z	Input and output pin for serial data
	24	DETO DO		Z	Signal detect output pin
	25	DVDD PWR		-	Digital VDD power supply pin.
	26	DVSS PWR		-	Digital VSS power supply pin.
	27	VREFD AO		Low	LDO re ference pin Connect the capacitor to stabilize LDO reference voltage.
	28	AVSS3 PWR		-	Analog VSS power supply pin
	29	AGNDOUT AO		Low	Analog ground output pin. Connect the capacitor to stabilize the analog ground level.
	30	AGNDIN AI		Low	Analog ground input pin. Connect the capacitor to stabilize the analog ground level.
	31	LOCAP AI		Note 6)	Local signal input pin
	32	LOIN AI		Note 6)	Local signal input pin

Note **A**: Analog, **D**: Digital, **PWR**: Power, **I**: Input, **O**: Output, **B**: Bidirectional, **Z**: High-Z, **L**: Low

Note 1) Connecting internally to VSS pin by 50k Ω

Note 2) Connecting internally to VDD pin by 720k Ω

Note 3) Connecting internally to VSS pin by 830k Ω

Note 4) Connecting internally to VSS pin by 50kΩ
 Note 5) Connecting internally to VSS pin by 480kΩ
 Note 5) Connecting internally to VDD pin by 139kΩ

• Pin Assignment

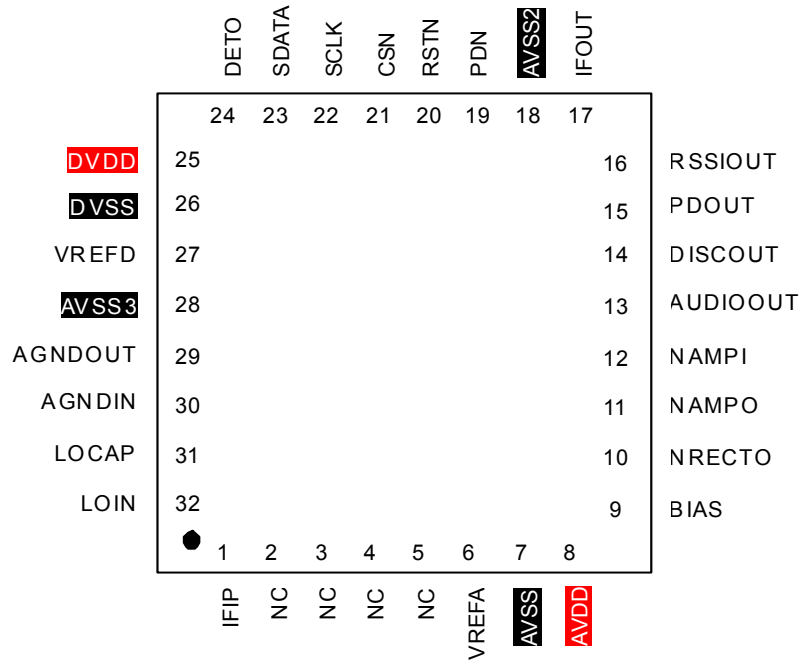

6. Absolute Maximum Ratings

Parameter Sy	mbol	Min.	Max.	Units
Power Supply Voltage	AVDD -0.3		6.5	V
	DVDD -0.3		6.5	V
Ground Level	VSS 0		0	V
Input Voltage	V _{IN} analog	-0.3	AVDD+0.3	V
	V _{IN} digital	-0.3	DVDD+0.3	V
Input Current (Except power supply pin)	I _{IN}	-10 +10		mA
Storage Temperature	T _{stg} -55		125	°C

Note : All voltages are relative to the VSS pin.

Caution : Exceeding these maximum ratings can result in damage to the device.
Normal operation cannot be guaranteed under this extreme.

7. Recommended Operating Conditions

Parameter Symbol		Condition	Min.	Typ.	Max.	Units
Operating Temperature	T _a		-40		85	°C
Power Supply Voltage	AVDD		2.6 3.0		5.5	V
	DVDD DVD D ≤ AVDD		2.6 3.0		5.5	V
Analog Reference Voltage	AGND AGNDOUT			1/2 VREFA	V	
Output Load Resistance	R _{L1}	AUDIOOUT, DISCOUNT, NAMPO	30			kΩ
Output Load Capacitance	C _{L1}	AUDIOOUT, DISCOU NT, NAMPO			15	pF
	C _{L2} IFOUT			21	26	pF

Note : All voltages are relative to the VSS pin.

8. Digital DC Characteristics

Parameter Symbol	Condition	Min.	Typ.	Max.	Units
High level input voltage	V_{IH} RSTN, SCLK, SDATA, CSN, PDN	0.8DVDD			V
Low level input voltage	V_{IL} RSTN, SCLK, SDATA, CSN, PDN			0.2DVDD	V
High level input current	I_{IH} $V_{IH}=DVDD$ RSTN, SCLK, SDATA, CSN, PDN			10	μA
Low level input current	I_{IL} $V_{IL}=0V$ RSTN, SCLK, SDATA, CSN, PDN	-10			μA
High level output voltage	V_{OH} $I_{OH}=+0.2mA$ SDATA	DVDD-0.4	DVD	D	V
Low level output voltage	V_{OL} $I_{OL}=-0.4mA$ SDATA, DETO	0.0		0.4	V

9. Digital AC Timing

1) Serial Interface Timing

AK2365 is connected to a CPU by three-wired interface through CSN, SCLK and SDATA pins, which can make reading and writing data for control registers.

Serial data named SDATA is consist of 1-bit read and write instruction(R/W), 6-bit address (A5 to A0) and 8-bit data(D7 to D0) in one frame.

Write mode

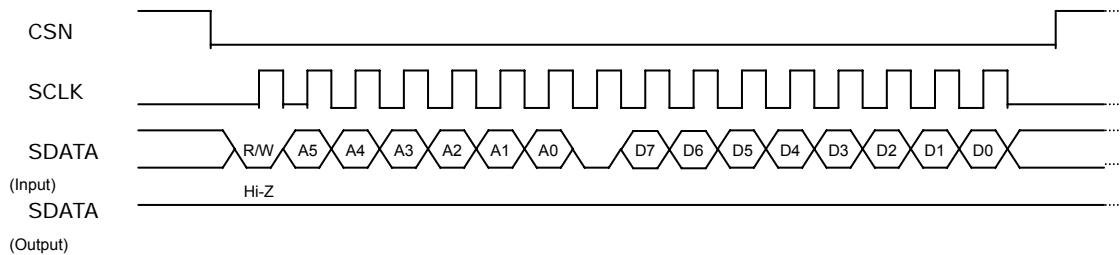

Read mode

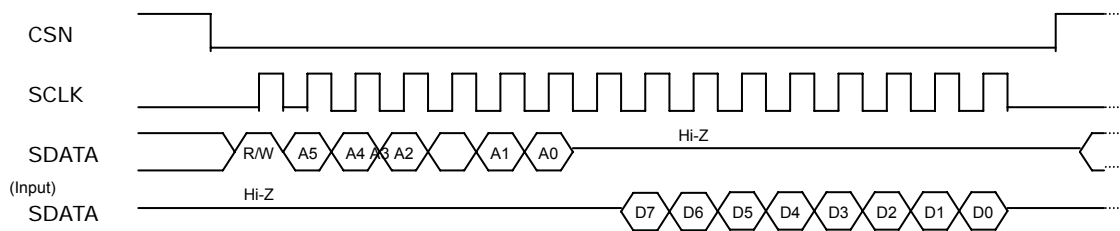

R/W : Instruction bit controls to write data to AK2365 or read back from it.
When set to low, AK2365 is in write mode. When set to high, AK2365 is in read mode.

A5 to A0: Register address to be accessed.
D7 to D0: Write or read data to be accessed.

- <1> CSN(Chip select) is normally selected high for disable.
When CSN is set to low, serial interface becomes active.
- <2> In write mode, instruction, address and data input from SDATA pin are synchronized and latched with the rising edge of 16 iterations of SCLK clock. Set to low between address A0 and data D7. Input data is fixed synchronized with the rising edge of 16th clock. Note that if CSN become "H" before 16th clock, setting data becomes invalid. During the period when CSN is set to "L", consecutive writing is available.
- <3> In read mode, instruction and address are synchronized and latched with the rising edge of 7 iterations of SCLK clock. And the register data are output from SDATA pin synchronized with the falling edge of 9 iterations of SCLK clock. The data between address A0 and data D7 is unstable. During the period when data is output, input to SDATA must be "Hi-z". Set CSN to "H" once reading is completed because consecutive reading is not valid.

2) Detail Timing Chart

Write mode

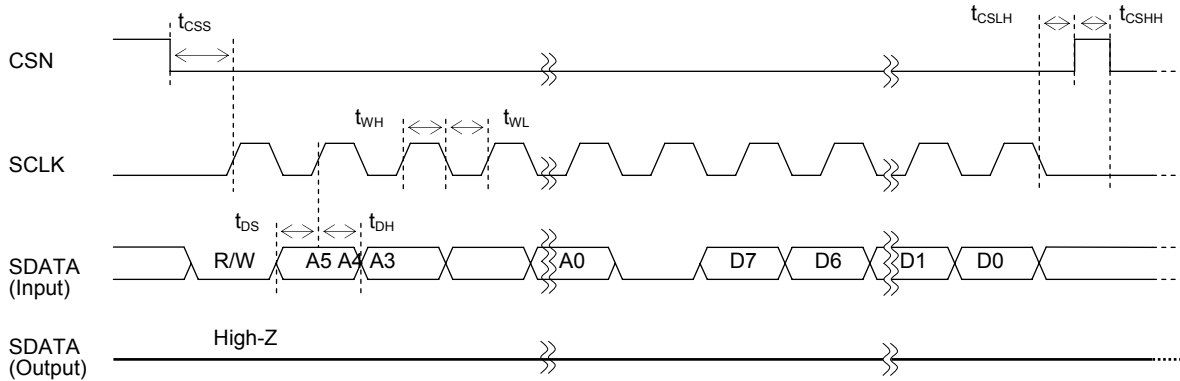

Read mode

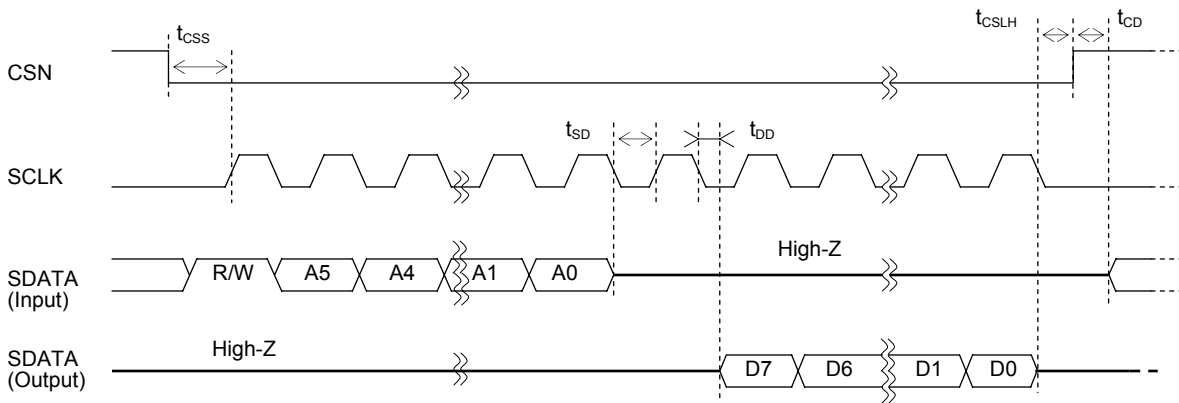

Rising and falling time

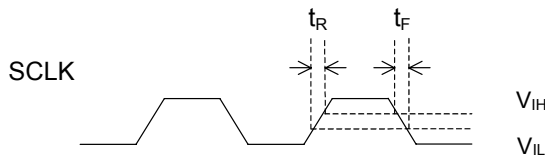

Parameter Symbol		Condition	Min.	Typ.	Max.	Unit
CSN setup time	t_{CSS}		100			ns
SDATA setup time	t_{DS}		100			ns
SDATA hold time	t_{DH}		100			ns
SCLK high time	t_{WH}		500			ns
SCLK low time	t_{WL}		500			ns
CSN low hold time	t_{CSLH}		100			ns
CSN high hold time	t_{CSHH}		100			ns
SDATA Hi-Z setup time	t_{SD}		500			ns
SCLK to SDATA output delay time	t_{DD}	20pF load			400	ns
CSN to SDATA input delay time	t_{CD}	20pF load	200			ns
SCLK rising time	t_R				250	ns
SCLK falling time	t_F				250	ns

Note) Digital input and output timing is relative to 0.5DVDD of rising signal and falling signal.

10. Power-up Sequence

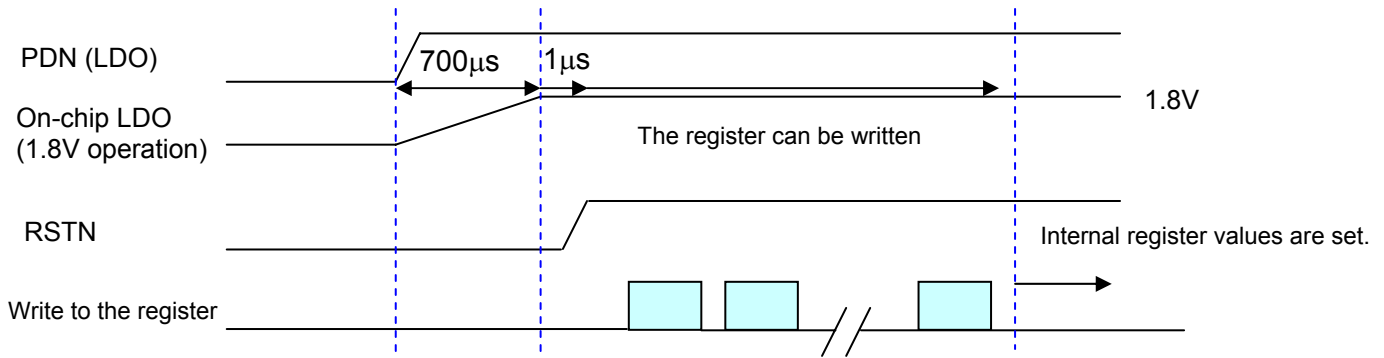

Note) After PDN is set to “High”, registers remain undefined. In order to initialize them, RSTN is set to “High”

11. System Reset

Parameter Symbol	Condition	Min.	Typ.	Max.	Unit	Remarks
Hardware reset signal input width	t_{RSTN} RSTN pin	1			µs	*1)
Software reset	SRST register					*2)

*1) After power-on, be sure to perform a hardware reset operation (register initialization). The system is reset by a low pulse input of 1µs (min.) and enters the normal operation state. At this moment, the digital (DI) pins are set as follows: RSTN pin to High, SCLK pin to Low, SDATA pin to Low, CSN pin to Low.

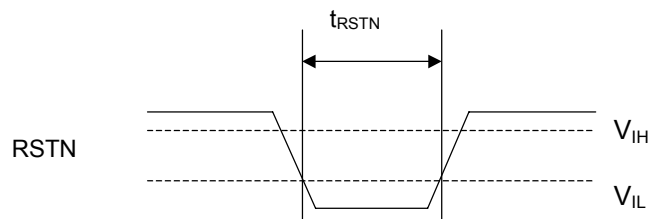

*2) When data 0x04:10101010 is written to the SRST[7:0] register, software reset is performed. This setting initializes the registers and the operation mode is set to mode 2 (Standby 2). After software reset is completed, this register comes to “0”.

12. Power Consumption

Parameter Symbol	Symbol	Condition	Min.	Typ.	Max.	Units
Power Consumption	IDD0	Mode 0 Power down			0.01	mA
	IDD1	Mode 1 Standby 1	0.3		0.6	
	IDD2	Mode 2 Standby 2	0.4		0.7	
	IDD3	Mode 3	1		1.6	
	IDD4	Mode 4 Digital Mode 1 with no signal input	5.6		7.5	
	IDD5	Mode 5 Digital Mode 2 with no signal input	6		8	
	IDD6	Mode 6 Analog Mode with no signal input	6		8	
	IDD7	Mode 7 Full Power On with no signal input	7		9.8	

13. Analog Characteristics

For the following conditions unless otherwise specified: Mode 6, LOIN=50.4MHz, IFIP=50.85MHz, $\Delta f = \pm 1.5\text{kHz}$, $f_{\text{mod}} = 1\text{kHz}$, AGC+BPF=F2, {AGC_OFF}=0, the exposure back pad of the package is connected to VSS, with the external circuit shown in example page 26 to 28.

1) Local

Parameter Symbol	Condition	Min.	Typ.	Max.	Units	Notes
Local Frequency	$F_{\text{LO LOIN}}$		45.9 50.4 57.6		MHz	
Input amplitude	$V_{\text{LO LOIN}}$	0.2		2.0	V _{PP} Note 1)	

Note 1) Input from LOIN pin through DC cut

2) 2nd Mixer

Parameter Condition	Min.	Typ.	Max.	Units	Notes
Input Impedance	50			Ω	Note 2)
Input Frequency		$F_{\text{LO}} + 0.45$		MHz	
Voltage Gain		28		dB	

Note 2) Include external matching circuit

3) Discriminator

Parameter Condition	Min.	Typ.	Max.	Units	Notes	
Demodulation Output Level	$\Delta f = \pm 3.0\text{kHz}$, $f_{\text{mod}} = 1\text{kHz}$, LIMITER IN to AUDIOOUT {BAND}=1	70	100	130	mVrms	
	$\Delta f = \pm 1.5\text{kHz}$, $f_{\text{mod}} = 1\text{kHz}$, LIMITER IN to AUDIOOUT {BAND}=0	70	100	130	mVrms	
S/N Ratio	$\Delta f = \pm 3.0\text{kHz}$, $f_{\text{mod}} = 1\text{kHz}$, $V_{\text{in}} = -16\text{dBm}$ LIMITER IN to AUDIOOUT {BAND}=1	43	50		dB	Note 3)

Note 3) With De-emphasis + BPF(0.3 to 3kHz)

4) RX Overall Characteristics

Parameter	Condition	Min.	Typ.	Max.	Units	Notes
12dB SINAD Input Sensitivity			-102		dBm	Note 4)
Total Gain	Mode 5 Maximum gain setting for AGC IFIP to IFOUT {IFOG[1:0]}=00	84			dB	
	Mode 5 Minimum gain setting for AGC IFIP to IFOUT {IFOG[1:0]}=00		32		dB	
C/N ratio	Mode 5, BPF=F3 IFIP to IFOUT When in CW, 450kHz, -102dBm Bandwidth: 450kHz \pm 3kHz {IFOG[1:0]}=00	17				
IIP3	Mode 5 Maximum gain setting for AGC IFIP=50.8635MHz&50.876MHz	-20			dBm	
Demodulation Output Level	$\Delta f = \pm 3.0\text{kHz}$, $f_{\text{mod}} = 1\text{kHz}$, AGC+BPF=F1, {BAND}=1	70	100	130	mVrms	
	$\Delta f = \pm 1.5\text{kHz}$, $f_{\text{mod}} = 1\text{kHz}$, AGC+BPF=F2, {BAND}=0	70	100	130	mVrms	
S/N Ratio	$\Delta f = \pm 3.0\text{kHz}$, $f_{\text{mod}} = 1\text{kHz}$, AGC+BPF=F1, $V_{\text{in}} = -47\text{dBm}$ {BAND}=1	40	50		dB	Note 4)
	$\Delta f = \pm 1.5\text{kHz}$, $f_{\text{mod}} = 1\text{kHz}$, AGC+BPF=F2, $V_{\text{in}} = -47\text{dBm}$ {BAND}=0	34	44		dB	Note 4)

Note 4) With De-emphasis+BPF(0.3 to 3kHz)

5) RSSI Characteristics

Parameter	Condition	Min.	Typ.	Max.	Units	Notes
RSSI Output Voltage	IFIP to RSSIOUT {AGC_OFF}=0, IFIP=-100dBm Input	0.05	0.3	0.7	V	
	IFIP to RSSIOUT {AGC_OFF}=0, IFIP=-30dBm Input	1.4	2.0	2.6	V	

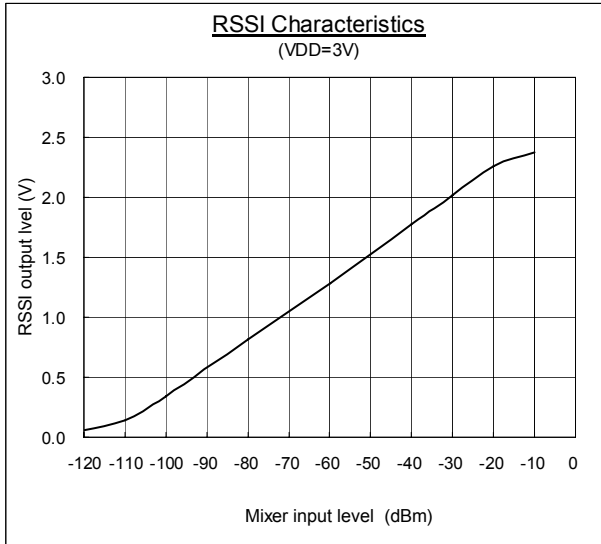

6) Noise Squelch Characteristics

Parameter	Condition	Min.	Typ.	Max.	Units	Notes
Noise Detection Level	NRECTO to DETO Detect High		0.5	0.7	V	
	NRECTO to DETO Detect Low	0.3	0.4		V	
Noise Detection Characteristic	NAMPI to NRECTO Input: 31kHz, 0.1mVrms	0.2	0.3	0.4	V	
	NAMPI to NRECTO Input: 31kHz, 0.25mVrms	0.5	0.65	0.8	V	

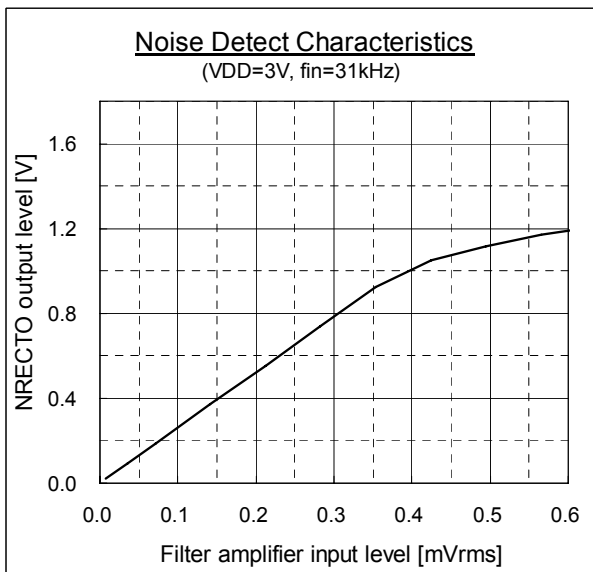

7) AGC+BPF Characteristics

7.1) F0 (E type)

Parameter Condition	Min.	Typ.	Max.	Units	Notes
Attenuation Characteristics (relative to the gain at 450kHz)	435kHz		-50	dB	
	442.5kHz	-6		dB	
	457.5kHz	-6		dB	
	465kHz		-50 dB		
Gain ripple	Within 450±5kHz		3	dB	

7.2) F1 (F type)

Parameter Condition	Min.	Typ.	Max.	Units	Notes
Attenuation Characteristics (relative to the gain at 450kHz)	437.5kHz		-50	dB	
	444kHz	-6		dB	
	456kHz	-6		dB	
	462.5kHz		-50 dB		
Gain ripple	Within 450±4kHz		3	dB	

7.3) F2 (G type)

Parameter Condition	Min.	Typ.	Max.	Units	Notes
Attenuation Characteristics (relative to the gain at 450kHz)	439kHz		-50	dB	
	445.5kHz	-6		dB	
	454.5kHz	-6		dB	
	461kHz		-50 dB		
Gain ripple	Within 450±3kHz		3	dB	

7.4) F3 (H type)

Parameter Condition	Min.	Typ.	Max.	Units	Notes
Attenuation Characteristics (relative to the gain at 450kHz)	441kHz		-50	dB	
	447kHz	-6		dB	
	453kHz	-6		dB	
	459kHz		-50 dB		
Gain ripple	Within 450±2kHz		2	dB	

7.5) F4 (J type)

Parameter Condition	Min.	Typ.	Max.	Units	Notes
Attenuation Characteristics (relative to the gain at 450kHz)	442.5kHz		-50	dB	
	448kHz	-6		dB	
	452kHz	-6		dB	
	457.5kHz		-50 dB		
Gain ripple	Within 450±1.5kHz		2	dB	

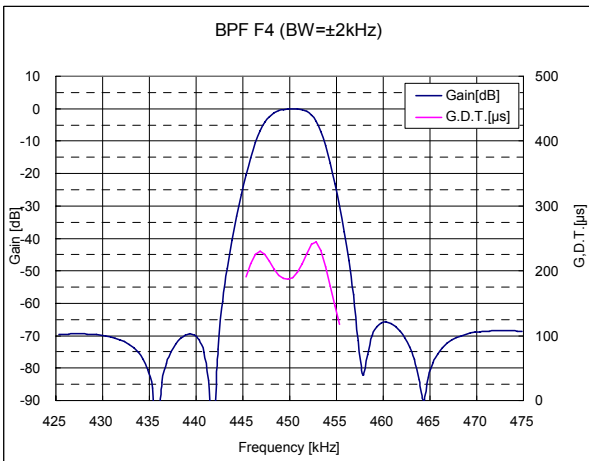
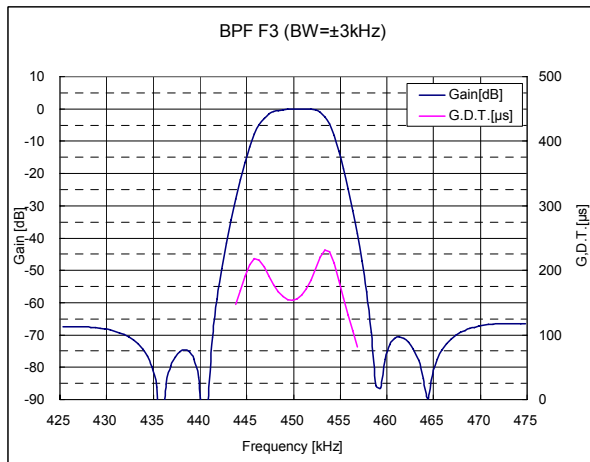
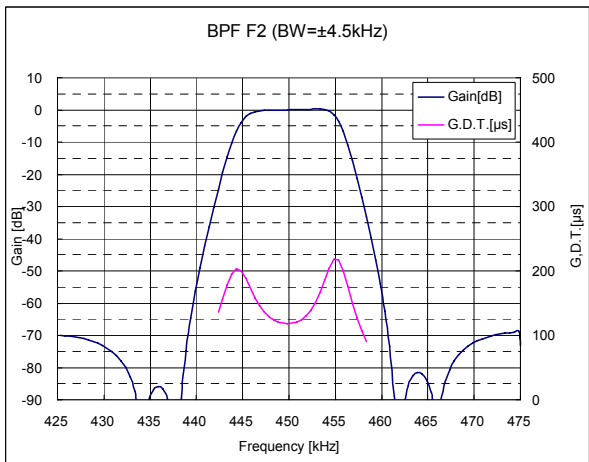
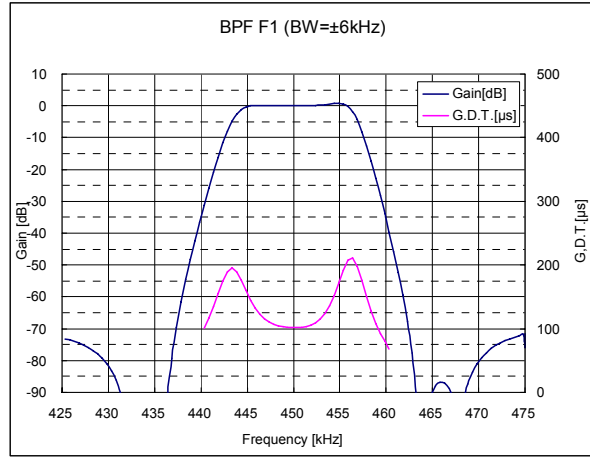
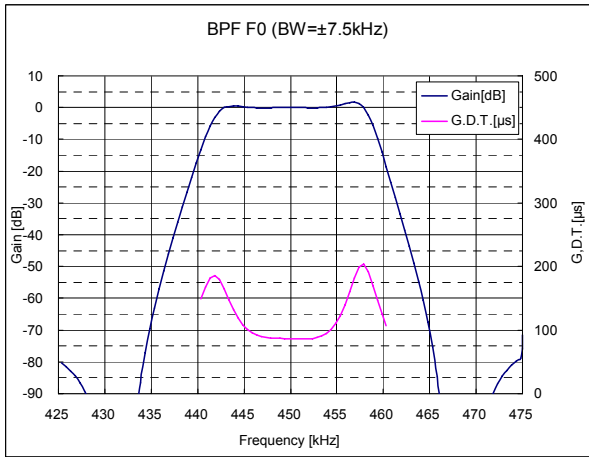

8) IFBUF Characteristics

Parameter Condition	Min.	Typ.	Max.	Units	Notes
Settling time	100			ns	IFBUF to IFOUT, IFBUF=0.32Vpp/step C _{L2} =21pF, {IFOG[1:0]}=00

Note: Convergence time within 1% when 0.32Vpp step signal input to IFBUF pin

14. Serial Interface Configuration

1) Register Configuration

Name	ADRS	D7(MSB)	D6	D5	D4	D3	D2	D1		D0(LSB)	W/R
Control register 1	0x01	BS[2:0]			BAND	BPF_BW[1:0]		LOFREQ[1:0]		W/R	
		0	1	0	0	0	0	0	1		
Control register 2	0x02	Reserved				AGC_TIME[1	:0]		AGC1_STEP	CAL	W/R
		0	0	1	1	0	0	1	0		
Control register 3	0x03	Reserved						IFOG[1:0]		W/R	
		0	0	0	0	0	0	0	0		
Software -reset	0x04	SRST[7:0]								W	
		—	—	—	—	—	—	—	—		
Reserved	0x05 to 0x0A	Reserved								—	
Control register 4	0x0B	BPF_BW [2]	AGC_OFF	AGC1_G[5:0]						W/R	
		0	0	0	0	0	0	0	0		1
Control register 5	0x0C	Reserved			AGC2_G[4:0]					W/R	
		1	0	0	0	0	0	0	0		0

Note: Do not access the data except specified address above.

2) Description of registers

Address 0x01 (Control Register 1)

Name	D7(MSB)	D6 D5	D4	D3 D2	D1	D0(LSB)
Control Register 1	BS[2:0]			BAND	BPF_BW[1:0]	LOFREQ[1:0]
Initial Value	0	1	0	0	0	0

BS[2:0]: Operation mode setting

PDN pin	BS[2]	BS[1]	BS[0]	Mode name	LDOD	LDOA, AGNDIN	VREF	MIX AGC, BPF, Divider	IFBUF	Limiter, RSSI	DISCRI, Noise Squelch
0	-	-	-	Mode 0 (Power-down)	OFF	OFF	OFF	OFF	OFF	OFF	OFF
1	0	0	1	Mode 1 (Standby 1)	<u>ON</u>	OFF	OFF	OFF	OFF	OFF	OFF
1	0	1	0	Mode 2 (Standby 2)	<u>ON</u>	<u>ON</u>	OFF	OFF	OFF	OFF	OFF
1 0 1			1	Mode 3	<u>ON</u>	<u>ON</u>	<u>ON</u>	OFF	OFF	OFF	OFF
1 1 0			0	Mode 4	<u>ON</u>	<u>ON</u>	<u>ON</u>	<u>ON</u>	<u>ON</u>	OFF	OFF
1 1 0			1	Mode 5	<u>ON</u>	<u>ON</u>	<u>ON</u>	<u>ON</u>	<u>ON</u>	<u>ON</u>	OFF
1 1 1			0	Mode 6	<u>ON</u>	<u>ON</u>	<u>ON</u>	<u>ON</u>	OFF	<u>ON</u>	<u>ON</u>
1 1 1			1	Mode 7	<u>ON</u>	<u>ON</u>	<u>ON</u>	<u>ON</u>	<u>ON</u>	<u>ON</u>	<u>ON</u>

Note: Do not set the combination of the code which is not defined in the table given above.

BAND: Demodulated signal level setting

BAND Fun	ction
0	Narrow
1	Wide

Note1: When {BAND} register is set to "0", demodulated signal level at AUDIOOUT pin, when input signal is $\Delta f = \pm 1.5\text{kHz}$ dev, is 100mVrms typ. When {BAND} register is set to "1", demodulated signal level at AUDIOOUT pin, when input signal is $\Delta f = \pm 3.0\text{kHz}$ dev, is 100mVrms typ.

BPF_BW[1:0]: BPF band width setting

BPF_BW [2]	BPF_BW [1]	BPF_BW [0]	name	6dB attenuation	Attenuation band width
1 0/1		0/1	F0	$\pm 7.5\text{kHz}$	$\pm 15\text{kHz}$
0	0	0	F1	$\pm 6\text{kHz}$	$\pm 12.5\text{kHz}$
0	0 1		F2	$\pm 4.5\text{kHz}$	$\pm 11\text{kHz}$
0	1 0		F3	$\pm 3\text{kHz}$	$\pm 9\text{kHz}$
0	1 1		F4	$\pm 2\text{kHz}$	$\pm 7.5\text{kHz}$

LOFREQ[1:0]: Local frequency setting

LOFREQ [1]	LOFREQ [0]	Local frequency
0	0	45.9MHz
0	1	50.4MHz
1	0	57.6MHz

Note: Do not set the combination of the code which is not defined in the table given above.

Address 0x02 (Control Register 2)

Name D7	(MSB)	D6	D5	D4	D3	D2	D1	D0(LSB)
Control Register 2	Reserved AGC_TIME[1:0]						AGC1_S TEP	CAL
Initial Value	0	0	1	1	0	0	1	0

AGC_TIME[1:0]: AGC response time setting

This register set response time for AGC1 gain and AGC2 gain to change by 1step.

AGC_TIME [1]	AGC_TIME [0]	AGC response time [ms]					
		AGC1_STEP=0 setting			AGC1_STEP=1 setting		
		State A	State B	State C	State A	State B	State C
0	0	0.56	8.50	8.50	0.38	4.35	4.35
0	1	0.92	8.79	8.79 0.56		4.50	4.50
1	0	1.64	9.37	9.37 0.93		4.79	4.79
1 1		3.08	10.52	10.52	1.66	5.38	5.38

Note 1: Values above indicate response time during AGC gain changes from maximum to minimum or from minimum to maximum.

State A: AGC1 output level is beyond the upper limit.

State B: AGC1 output level is within the upper limit and AGC2 output level is beyond the upper limit.

State C: AGC2 output level is under the lower limit.

Data Func	tion	Operation		Notes
		0	1	
AGC1_ST EP	AGC1 gain switching range setting	±1dB	±2dB	
CAL	Discriminator circuit calibration start trigger (Note2)	Invalid Start		

Note 2: calibration is performed synchronized with the rising edge of {CAL}. After calibration is completed, this register is set to "0" automatically. It takes 1.3ms before calibration is completed. Refer to "calibration procedure" for further information.

Address 0x03 (Control Register 3)

Name	D7(MSB)	D6	D5 D4	D3 D2	D1	D0(LSB)
Control Register 3	Reserved					IFOG[1:0]
Initial Value	0	0	0	0	0	0

IFOG[1:0]: IFBUF Gain setting

IFOG [1]	IFOG [0]	IFBUF Gain[dB]
0	0	6
0	1	9
1	0	12
1	1	15

Address 0x04 (Software Reset)

Name	D7(MSB)	D6 D5	D4 D3	D2 D1	D0(LSB)
Software-reset	SRST[7:0]				
Initial Value	—	—	—	—	—

When data 0x04:10101010 is written to the SRST[7:0] register, software reset is performed. Refer to System Reset for further information.

Address 0x0B (Control Register 4)

Name	D7(MSB)	D6	D5 D4	D3	D2	D1	D0(LSB)
Control Register 4	BPF_BW [2]	AGC_OFF	AGC1_G[5:0]				
Initial Value	0	0	0	0	0	0	1

Data Func	tion	Operation		Notes
		0	1	
BPF_BW[2]	F0 (±7.5kHz)	OFF	ON	
AGC_OFF	AGC function	Disable (AGC Auto operation)	Enable (AGC manual operation)	
AGC1_G[5:0]	AGC1 gain adjustment	21 to -19dB by 1dB step		Available only {AGC_OFF}=1

AGC1_G[5]	AGC1_ G[4]	AGC1_ G[3]	AGC1_G[2]	AGC1_G[1]	AGC1_G[0]	Gain [dB]
0 1 0 1 0 1						21
0 1 0 1 0 0						20
0 1 0 0 1 1						19
0 1 0 0 1 0						18
0 1 0 0 0 1						17
0 1 0 0 0 0						16
0 0 1 1 1 1						15
0 0 1 1 1 0						14
0 0 1 1 0 1						13
0 0 1 1 0 0						12
0 0 1 0 1 1						11
0 0 1 0 1 0						10
0 0 1 0 0 1						9
0 0 1 0 0 0						8
0 0 0 1 1 1						7
0 0 0 1 1 0						6
0 0 0 1 0 1						5
0 0 0 1 0 0						4
0 0 0 0 1 1						3
0 0 0 0 1 0						2
0	0	0	0	0	1	1
0 0 0 0 0 0						0
1 1 1 1 1 1						-1
1 1 1 1 1 0						-2
1 1 1 1 0 1						-3
1 1 1 1 0 0						-4
1 1 1 0 1 1						-5
1 1 1 0 1 0						-6
1 1 1 0 0 1						-7
1 1 1 0 0 0						-8
1 1 0 1 1 1						-9
1 1 0 1 1 0						-10
1 1 0 1 0 1						-11
1 1 0 1 0 0						-12
1 1 0 0 1 1						-13
1 1 0 0 1 0						-14
1 1 0 0 0 1						-15
1 1 0 0 0 0						-16
1 0 1 1 1 1						-17
1 0 1 1 1 0						-18
1 0 1 1 0					1	-19

Note: Do not set the combination of the code which is not defined in the table given above.

Address 0x0C (Control Register 5)

Name	D7(MSB)	D6	D5	D4	D3 D2	D1		D0(LSB)
Control Register 5	Reserved			AGC2_G[4:0]				
Initial Value	1	0	0	0	0	0	0	0

Data Func	tion	Operation		Notes
		0	1	
AGC2_G[4:0]	AGC2 gain adjustment	12 to 0dB by 1dB step		Available only {AGC_OFF}=1

AGC2_G[4]	AGC2_ G[3]	AGC2_ G[2]	AGC2_G[1]	AGC2_G[0]	Gain [dB]
0 1 1 0 0					12
0 1 0 1 1					11
0 1 0 1 0					10
0 1 0 0 1					9
0 1 0 0 0					8
0 0 1 1 1					7
0 0 1 1 0					6
0 0 1 0 1					5
0 0 1 0 0					4
0 0 0 1 1					3
0 0 0 1 0					2
0 0 0 0 1					1
0	0	0	0	0	0

Note: Do not set the combination of the code which is not defined in the table given above.

15. Calibration Procedure

AK2365 employs a function to calibrate free-running frequency of VCO in Discriminator and demodulated signal level. Before starting RX Operation, calibration is required in order to acquire proper VCO operation range and demodulated signal level.

Following procedure is required before calibration.

- <1> Start up the external TCXO and continuously supply LO signal to AK2365.
- <2> Set "110" to 0x01 {BS[2:0]} and start up all circuits. After this operation, the circuits necessary for calibration (LOBUF, VIREF, Discriminator) will be powered on and calibration can be possible in 500us.
- <3> Calibration is begun by setting "1" to address 0x02 {CAL}. When the calibration is executed once, the calibration operation cannot be stopped excluding master reset. Even if "0" is written in {CAL}, the calibration is completely executed.
- <4> Calibration data is maintained excluding the time when the master reset is executed or DVDD power supply is down.
- <5> It takes 1.5ms for Discriminator to become steady after the calibration is completed.

Power-up sequence recommendation

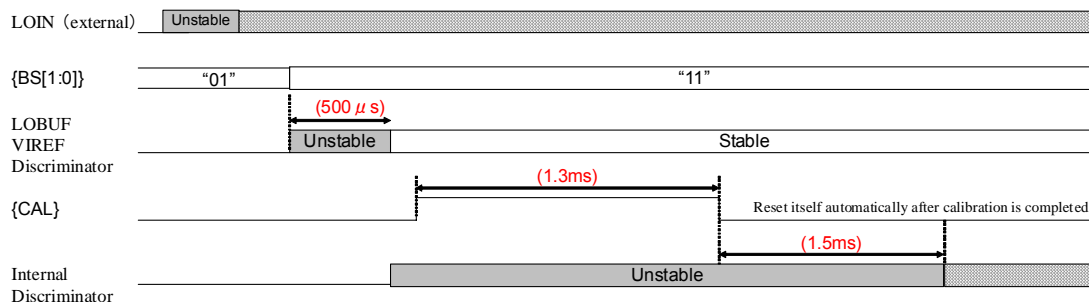

16. AGC Operation

AK2365 has two AGC circuits, AGC1 and AGC2. The signal level from IFIP pin is adjustable automatically by AGC1/2. The following graphs show IFIP input vs. IFOUT output characteristics by setting {AGC1_STEP}=0/1, {IFOG[1:0]}=00, {AGC_OFF}=0. Setting {AGC_OFF}=1 can disable automatic gain adjustable operation and also enable manual gain operation by {AGC1_G[5:0]}, {AGC2_G[4:0]} registers.

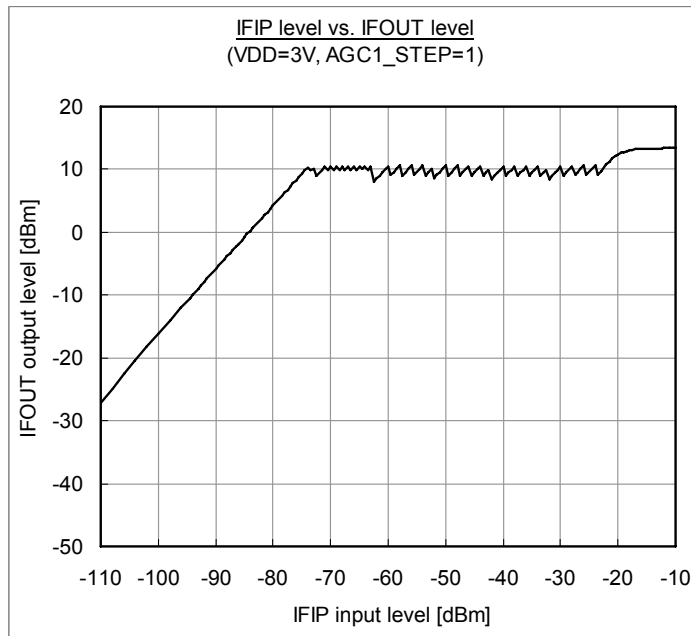
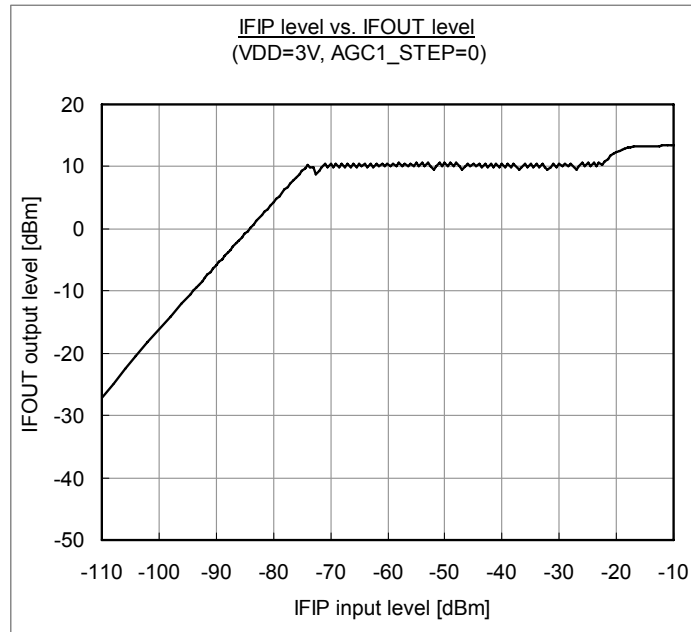

17. Recommended External Application Circuits

1) Power supply stabilizing capacitors

Connect capacitors between VDD and VSS pins to eliminate ripple and noise included in power supply. For maximum effect, the capacitors should be placed at a shortest distance between the pins.

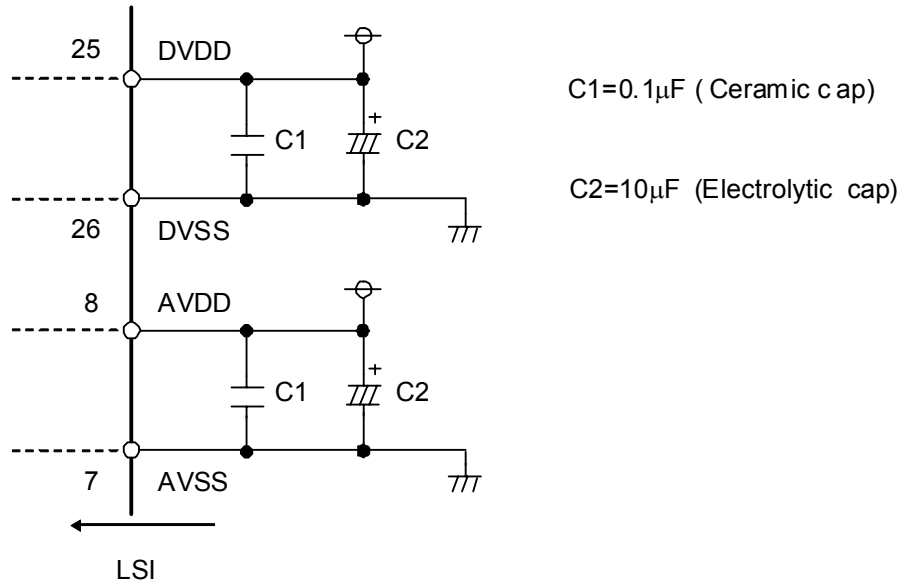

2) AGND stabilizing capacitors

It is recommended that capacitors with 1 μ F or larger be connected between VSS and the AGND and AGNDIN pins to stabilize the AGND signal. The capacitors must be placed as close to the pins as possible.

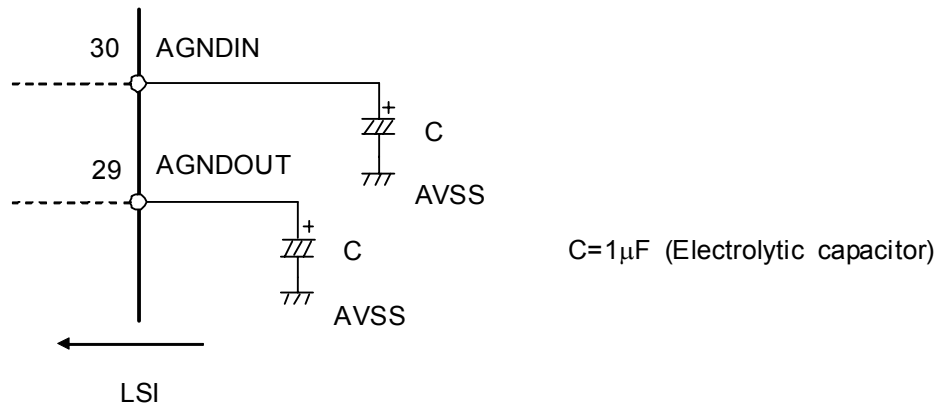

3) BIAS pin

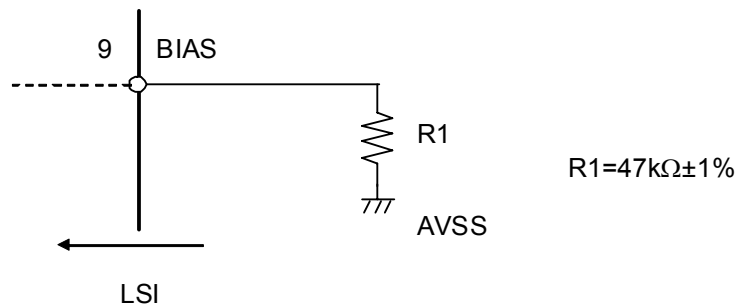

4) VREFA output

It is recommended that capacitors with 220nF or larger be connected between AVSS and VREFA pin to stabilize the VREFA signal. The capacitors must be placed as close to the pins as possible.

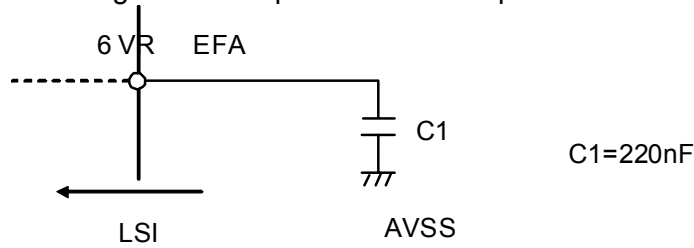

5) VREFD output

It is recommended that capacitors with 220nF or larger be connected between DVSS and VREFD pin to stabilize the VREFD signal. The capacitors must be placed as close to the pins as possible.

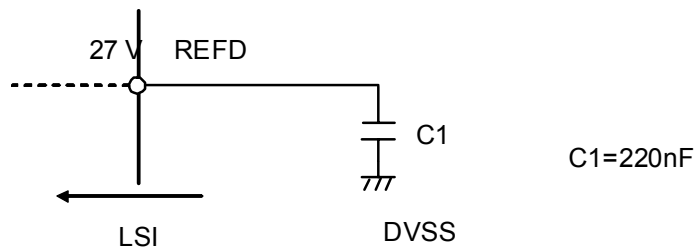

6) MI X

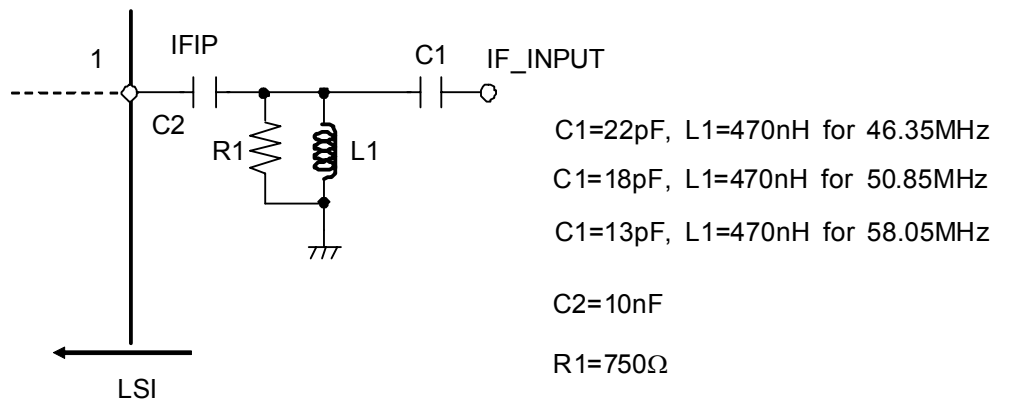

7) LOIN

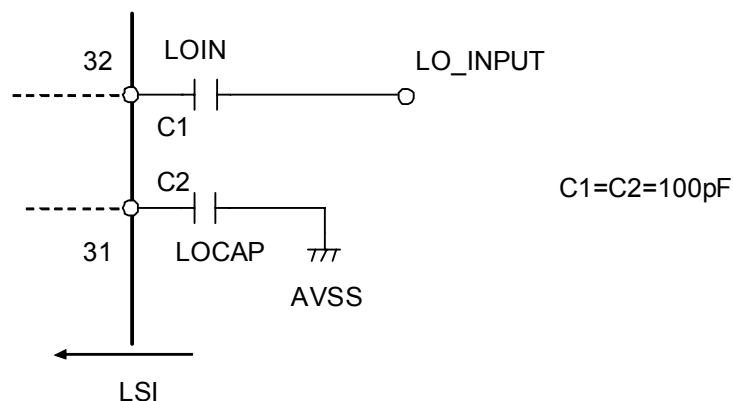

8) Discriminator

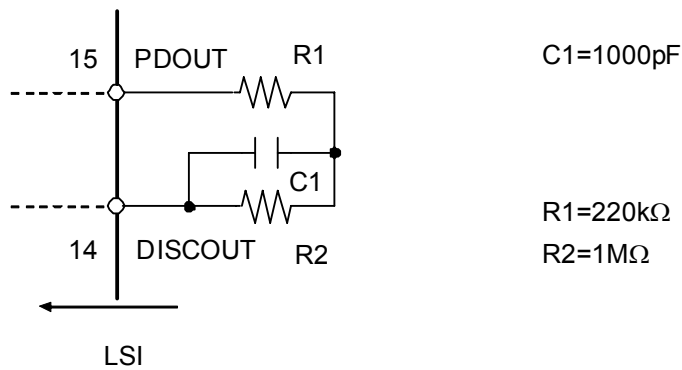

9) Noise AMP

The following gives a sample configuration of a BPF when input frequency is 31kHz. Some parameters can be calculated using following (1) to (3) equations.

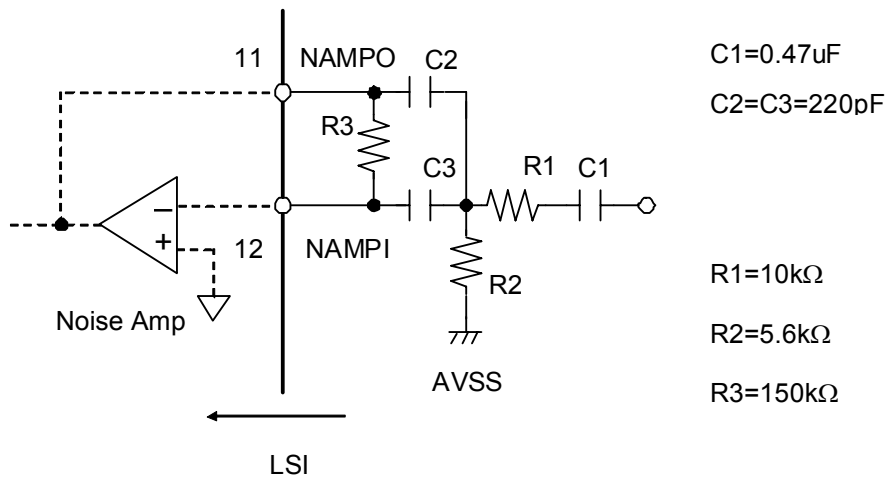

$$(1) f_0 = \frac{1}{2\pi\sqrt{R_3(R_1 // R_2)C^2}}$$

$$(2) G_v = \frac{R_3}{2R_1}$$

$$(3) Q^2 = \frac{R_3}{4(R_1 // R_2)}$$

10) NECTO pin

Rise time of noise detection is proportionate to $C1=0.1\mu\text{F}$ and internal resistance $75\text{k}\Omega$

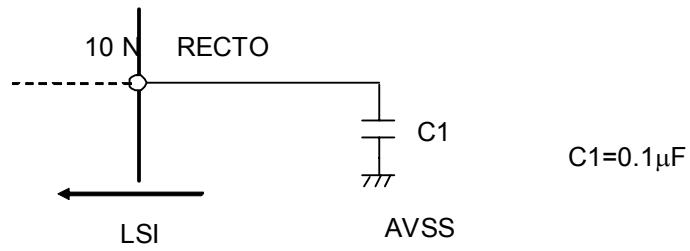

11) RSSIOUT pin

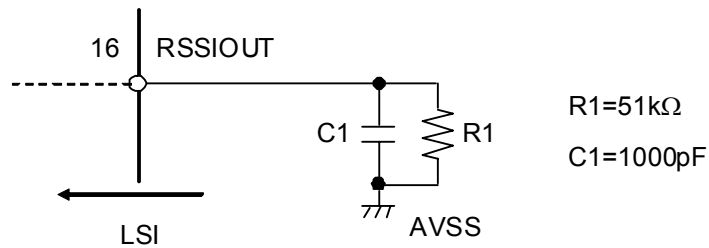

12) DETO

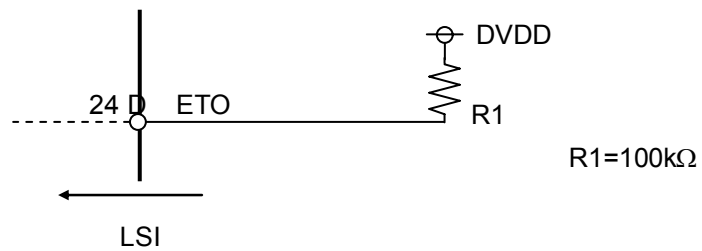

18. Packaging

Marking

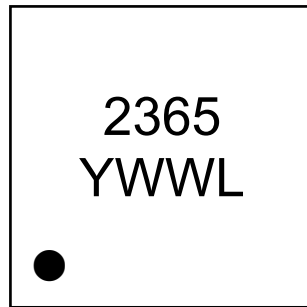

[Contents of YWWL]

Y: Last digit of calendar year. (Year 2011->1, 2012->2)

WW: Manufacturing week number.

L: Lot identification, given to each product lot which is made in a week.
 LOT ID is given in alphabetical order (A, B, C...).

Mechanical Outline

Package : 32pin QFN (4.0 x 4.0 x 0.7mm, 0.4mm pitch)

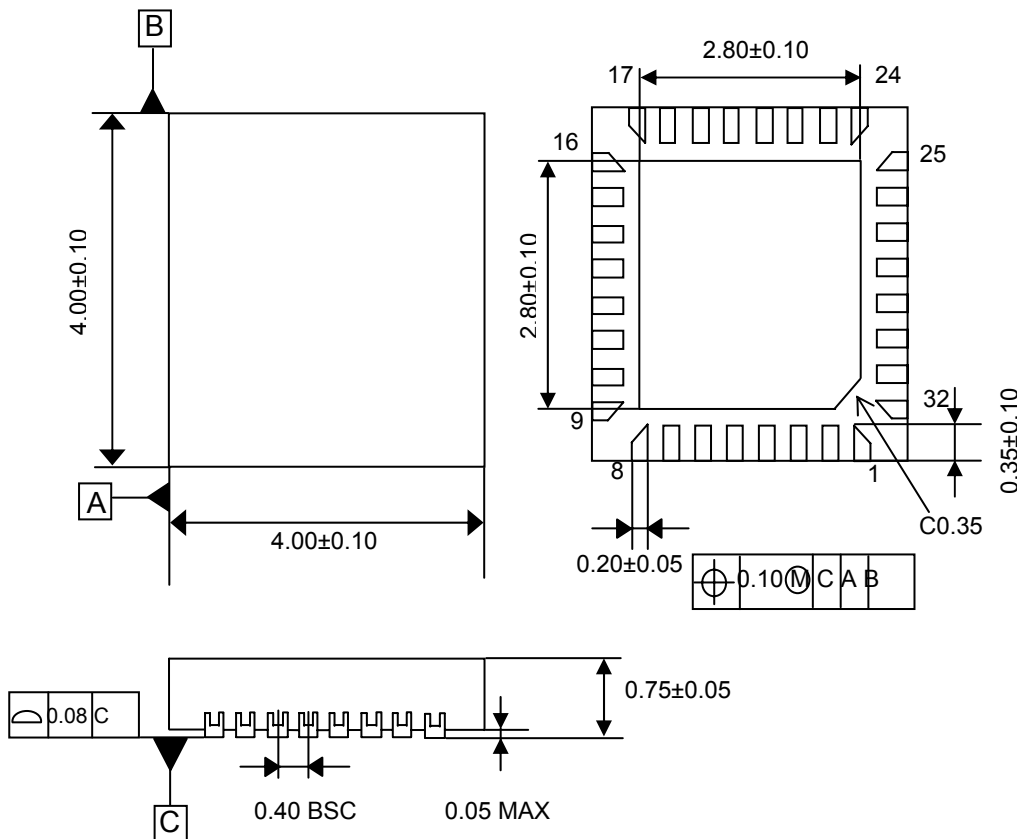

Note) The exposure pad(Exposed Pad) of the center of the package back is connected to opening or VSS.

19. Important Notice

IMPORTANT NOTICE

- These products and their specifications are subject to change without notice. When you consider any use or application of these products, please make inquiries the sales office of Asahi Kasei Microdevices Corporation (AKM) or authorized distributors as to current status of the products.
- Descriptions of external circuits, application circuits, software and other related information contained in this document are provided only to illustrate the operation and application examples of the semiconductor products. You are fully responsible for the incorporation of these external circuits, application circuits, software and other related information in the design of your equipments. AKM assumes no responsibility for any losses incurred by you or third parties arising from the use of these information herein. AKM assumes no liability for infringement of any patent, intellectual property, or other rights in the application or use of such information contained herein.
- Any export of these products, or devices or systems containing them, may require an export license or other official approval under the law and regulations of the country of export pertaining to customs and tariffs, currency exchange, or strategic materials.
- AKM products are neither intended nor authorized for use as critical components^{Note1)} in any safety, life support, or other hazard related device or system^{Note2)}, and AKM assumes no responsibility for such use, except for the use approved with the express written consent by Representative Director of AKM. As used here:
 - Note1) A critical component is one whose failure to function or perform may reasonably be expected to result, whether directly or indirectly, in the loss of the safety or effectiveness of the device or system containing it, and which must therefore meet very high standards of performance and reliability.
 - Note2) A hazard related device or system is one designed or intended for life support or maintenance of safety or for applications in medicine, aerospace, nuclear energy, or other fields, in which its failure to function or perform may reasonably be expected to result in loss of life or in significant injury or damage to person or property.
- It is the responsibility of the buyer or distributor of AKM products, who distributes, disposes of, or otherwise places the product with a third party, to notify such third party in advance of the above content and conditions, and the buyer or distributor agrees to assume any and all responsibility and liability for and hold AKM harmless from any and all claims arising from the use of said product in the absence of such notification.