



# AK4376A

## Low-Power Advanced 32-bit DAC with HP

### 1. General Description

The AK4376A is stereo advanced 32-bit high sound quality audio DAC with a built-in ground-referenced headphone amplifier. An internal circuit newly developed 32-bit digital filters for better sound quality, achieving low distortion characteristics and wide dynamic range. The sampling frequency supports up to 384 kHz. The AK4376A is available in a 36-pin CSP package, utilizing less board space than competitive offerings.

### 2. Features

1. Stereo High Sound Quality Low Power Advanced 32-bit DAC
  - 4 types of Digital Filter for Sound Color Selection
  - 2 types of Operation Mode (High Performance Mode / Low Power Mode)
2. Ground-referenced Class-G Stereo Headphone-Amp
  - Output Power: 25 mW @ 32Ω, THD+N < -60 dB  
45 mW @ 16Ω, THD+N < -60 dB
  - THD+N: -107 dB
  - S/N: 125 dB
  - Output Noise Level: -125 dBV (Analog Volume ≤ -14 dB)
  - Analog Volume: +6 to -20 dB & Mute, 2 dB Step
  - Ground Loop Noise Cancellation
3. HeadPhone-Amp Output comply with IEC61000-4-2 Level4 ESD Protection
4. Digital Audio interface
  - Master/Slave mode
  - Sampling Frequency:
    - Slave Mode: 8 k, 11.025 k, 12 k, 16 k, 22.05 k, 24 k, 32 k, 44.1 k, 48 k, 64 k, 88.2 k, 96 k, 128 k, 176.4 k, 192 kHz, 256 k, 352.8 k, 384 kHz
    - Master Mode: 8 k, 11.025 k, 12 k, 16 k, 22.05 k, 24 k, 32 k, 44.1 k, 48 k, 64 k, 88.2 k, 96 k, 176.4 k, 192 kHz
  - Interface Format: 32/24/16-bit I<sup>2</sup>S/MSB justified
5. Power Management
6. PLL
7. X'tal Oscillator
8. μP I/F: I<sup>2</sup>C (400 kHz)
9. Ta = -40 to 85°C
10. Power Supply:
  - AVDD (DAC, PLL): 1.7 to 1.9 V
  - CVDD (HP-Amp, Charge Pump): 1.7 to 1.9 V
  - LVDD (LDO2 for Digital Core): 1.7 to 1.9 V (built-in LDO)
  - TVDD (Audio I/F): 1.65 to 3.6 V
11. Package: 36-pin CSP (2.74 x 2.56 mm, 0.4 mm pitch)

<b>3. Table of Contents</b>
-----------------------------

1.	General Description .....	1
2.	Features .....	1
3.	Table of Contents .....	2
4.	Block Diagram and Functions .....	4
5.	Pin Configurations and Functions .....	5
	■ Pin Configurations .....	5
	■ Pin Functions .....	6
	■ Handing of Unused Pins .....	8
6.	Absolute Maximum Ratings .....	9
7.	Recommended Operating Conditions .....	9
8.	Electrical Characteristics .....	10
	■ Analog Characteristics .....	10
	■ PLL Characteristics .....	13
	■ Charge Pump & LDO Circuit Power-up Time .....	13
	■ Power Supply Current .....	13
	■ Power Consumptions for Each Operation Mode .....	14
	■ DAC Sharp Roll-Off Filter (fs = 44.1 kHz) .....	15
	■ DAC Sharp Roll-Off Filter (fs = 96 kHz) .....	15
	■ DAC Sharp Roll-Off Filter (fs = 192 kHz) .....	16
	■ DAC Slow Roll-Off Filter (fs = 44.1 kHz) .....	17
	■ DAC Slow Roll-Off Filter (fs = 96 kHz) .....	17
	■ DAC Slow Roll-Off Filter (fs = 192 kHz) .....	18
	■ DAC Short Delay Sharp Roll-Off Filter (fs = 44.1 kHz) .....	19
	■ DAC Short Delay Sharp Roll-Off Filter (fs = 96 kHz) .....	19
	■ DAC Short Delay Sharp Roll-Off Filter (fs = 192 kHz) .....	20
	■ DAC Short Delay Slow Roll-Off Filter (fs = 44.1 kHz) .....	21
	■ DAC Short Delay Slow Roll-Off Filter (fs = 96 kHz) .....	21
	■ DAC Short Delay Slow Roll-Off Filter (fs = 192 kHz) .....	22
	■ DC Characteristics .....	23
	■ Switching Characteristics .....	24
	■ Timing Diagram (System Clock) .....	26
	■ Timing Diagram (Serial Audio I/F) .....	27
	■ Timing Diagram (I <sup>2</sup> C Interface) .....	28
	■ Timing Diagram (Reset) .....	28
9.	Functional Description .....	29
	■ System Clock .....	29
	■ PLL .....	33
	■ Input Clock Select Function .....	33
	■ DACMCLK Generating Divider Setting .....	36
	■ Crystal Oscillator .....	36
	■ DAC Digital Filter .....	37
	■ Digital Mixing .....	37
	■ Digital Volume .....	38
	■ Headphone Amplifier Output (HPL/HPR pins) .....	39
	■ Charge Pump & LDO Circuits .....	47
	■ Serial Audio Interface .....	48
	■ Power-up & Operation Mode .....	49
	■ Serial Control Interface (I <sup>2</sup> C-bus) .....	50
	■ Control Sequence .....	54
	■ Register Map .....	56

- Register Definitions ..... 57
- 10. Recommended External Circuits ..... 63
- 11. Package ..... 65
  - Outline Dimensions ..... 65
  - Material and Lead Finish ..... 65
  - Marking ..... 66
- 12. Ordering Guide ..... 66
- 13. Revision History ..... 67
- IMPORTANT NOTICE ..... 68

4. Block Diagram and Functions

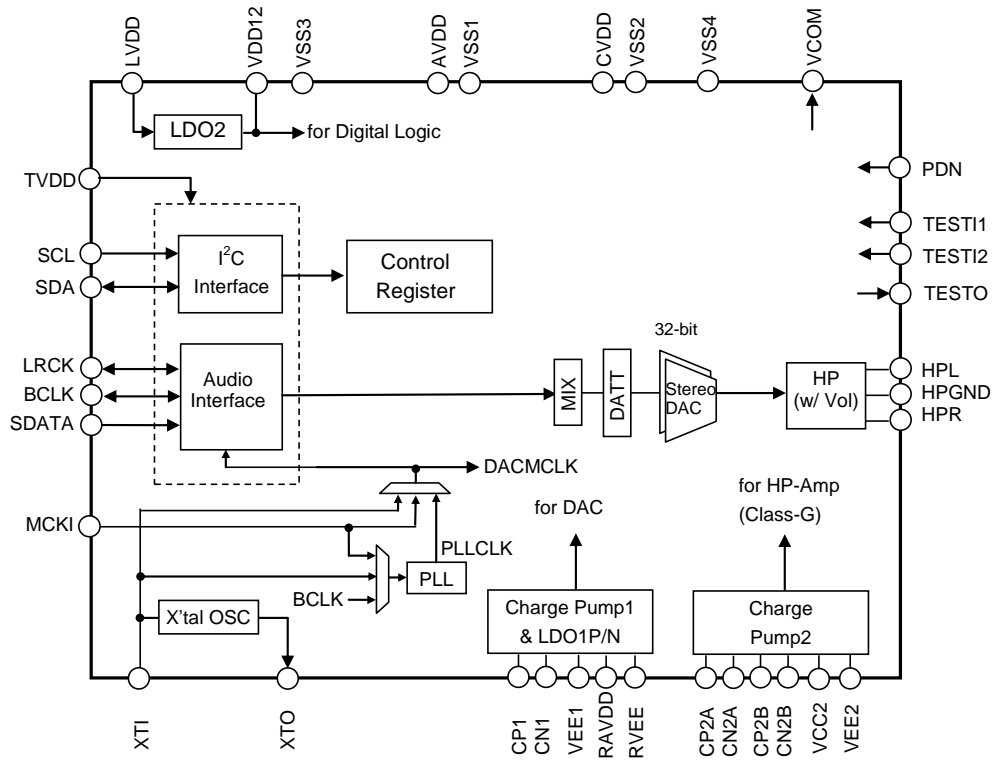
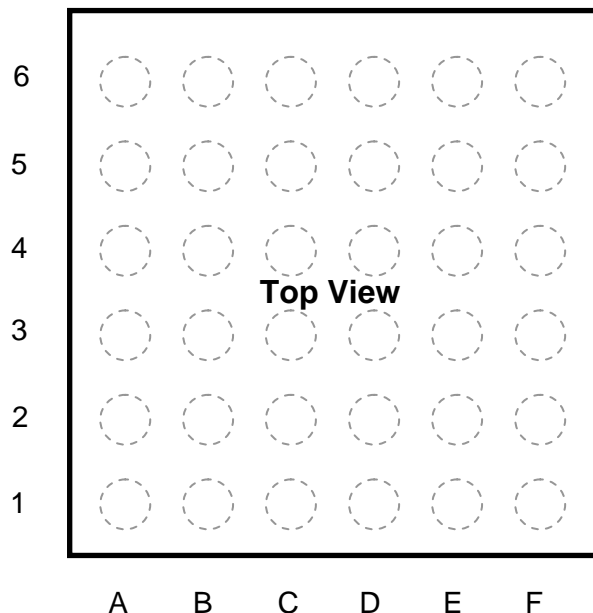

Figure 1. Block Diagram

**5. Pin Configurations and Functions**

■ Pin Configurations

36-pin CSP (2.74 x 2.56 mm, 0.4 mm pitch)



6	VDD12	SDATA	LVDD	VEE1	CN1	CVDD
5	VSS3	LRCK	PDN	CP1	CP2B	CN2B
4	BCLK	TVDD	TESTI1	VSS2	CP2A	CN2A
3	MCKI	SDA	TESTI2	TESTO	VCC2	VEE2
2	XTO	SCL	VSS4	VSS1	HPGND	HPR
1	XTI	RAVDD	RVEE	AVDD	VCOM	HPL
	<b>A</b>	<b>B</b>	<b>C</b>	<b>D</b>	<b>E</b>	<b>F</b>

**Top View**

## ■ Pin Functions

No.	Pin Name	I/O	Function	Protection Diode	Power Domain
<b>Power Supply</b>					
D1	AVDD	-	Analog Power Supply Pin		AVDD
D2	VSS1	-	Analog Ground Pin		
F6	CVDD	-	HP-Amp/Charge Pump Power Supply Pin		CVDD
D4	VSS2	-	HP-Amp/Charge Ground Pin		
C6	LVDD	-	Digital Core & LDO2 Power Supply Pin		LVDD
A5	VSS3	-	Digital Ground Pin		
C2	VSS4	-	Substrate Pin		
B4	TVDD	-	Digital I/F Power Supply Pin		TVDD
E1	VCOM	O	Common Voltage Output Pin This pin must be connected to the VSS1 pin with a 10 $\mu\text{F}$ $\pm 50\%$ Ceramic capacitor in series.	AVDD/ VSS1	
A6	VDD12	-	LDO2 (1.2 V) Output Power Supply Pin ( <a href="#">Note 1</a> ) This pin must be connected to the VSS3 pin with a capacitor in series.	LVDD/ VSS1	LVDD

Note 1. Capacitor value for the VDD12 pin should be selected from 2.2  $\mu\text{F}$   $\pm 50\%$  to 4.7  $\mu\text{F}$   $\pm 50\%$ .

Note 2. Do not connect a load to VCOM pin and VDD12 pin.

No.	Pin Name	I/O	Function	Protection Diode	Power Domain
<b>Charge Pump &amp; LDO</b>					
E3	VCC2	O	Charge Pump Circuit Positive Voltage Output Pin (CVDD or 1/2*CVDD) This pin must be connected to the VSS2 pin with a 2.2 $\mu\text{F}$ $\pm 50\%$ capacitor in series.	CVDD/ VSS2	CVDD
E4	CP2A	O	Positive Charge-Pump Capacitor Terminal 2A Pin This pin must be connected to the CN2A pin with a 2.2 $\mu\text{F}$ $\pm 50\%$ capacitor in series.	CVDD/ VSS2	CVDD
F4	CN2A	I	Negative Charge Pump Capacitor Terminal 2A Pin This pin must be connected to the CP2A pin with a 2.2 $\mu\text{F}$ $\pm 50\%$ capacitor in series.	CVDD	CVDD
E5	CP2B	O	Positive Charge Pump Capacitor Terminal 2B Pin This pin must be connected to the CN2B pin with a 2.2 $\mu\text{F}$ $\pm 50\%$ capacitor in series.	CVDD/ VSS2	CVDD
F5	CN2B	I	Negative Charge Pump Capacitor Terminal 2B Pin This pin must be connected to the CP2B pin with a 2.2 $\mu\text{F}$ $\pm 50\%$ capacitor in series.	CVDD	CVDD
F3	VEE2	O	Charge Pump Circuit Negative Voltage (-CVDD or -1/2*CVDD) Output 2 Pin This pin must be connected to the VSS2 pin with a 2.2 $\mu\text{F}$ $\pm 50\%$ capacitor in series.	CVDD/ VSS2	
D5	CP1	O	Positive Charge Pump Capacitor Terminal 1 Pin This pin must be connected to the CN1 pin with a 1 $\mu\text{F}$ $\pm 50\%$ capacitor in series.	CVDD/ VSS2	CVDD
E6	CN1	I	Negative Charge Pump Capacitor Terminal 1 Pin This pin must be connected to the CP1 pin with a 1 $\mu\text{F}$ $\pm 50\%$ capacitor in series.	CVDD	CVDD
D6	VEE1	O	Charge Pump Circuit Negative Voltage (-CVDD) Output 1 Pin This pin must be connected to the VSS2 pin with a 1 $\mu\text{F}$ $\pm 50\%$ capacitor in series.	CVDD/ VSS2	
B1	RAVDD	O	LDO1P (1.5V) Output Pin (Note 3) This pin must be connected to the VSS1 pin with a capacitor in series.	AVDD/ VSS1	
C1	RVEE	O	LDO1N (-1.5V) Output Pin (Note 3) This pin must be connected to the VSS1 pin with a capacitor in series.	AVDD/ VSS1	

Note 3. Capacitor values for the RAVDD pin and RVEE pin should be selected from 1  $\mu\text{F}$   $\pm 50\%$  to 4.7  $\mu\text{F}$   $\pm 50\%$ .

Note 4. Do not connect a load to VEE1 pin, VCC2 pin, VEE2 pin, RAVDD pin and RVEE pin.

No.	Pin Name	I/O	Function	Protection Diode	Power Domain
<b>Control Interface</b>					
B2	SCL	I	I <sup>2</sup> C Serial Data Clock Pin	TVDD/ VSS3	TVDD
B3	SDA	I/O	I <sup>2</sup> C Serial Data Input/Output Pin	TVDD/ VSS3	TVDD
<b>Audio Interface</b>					
A3	MCKI	I	External Master Clock Input Pin	TVDD/ VSS3	TVDD
A1	XTI	I	X'tal Oscillator Input Pin	AVDD/ VSS1	AVDD
A2	XTO	O	X'tal Oscillator Output Pin	AVDD/ VSS1	AVDD
A4	BCLK	I/O	Audio Serial Data Clock Pin	TVDD/ VSS3	TVDD
B5	LRCK	I/O	Frame Sync Clock Pin	TVDD/ VSS3	TVDD
B6	SDATA	I	Audio Serial Data Input Pin	TVDD/ VSS3	TVDD
<b>Analog Output</b>					
F1	HPL	O	Lch Headphone-Amp Output Pin	CVDD/ VEE2	CVDD/ VEE2
F2	HPR	O	Rch Headphone-Amp Output Pin	CVDD/ VEE2	CVDD/ VEE2
E2	HPGND	I	Headphone-Amp Ground Loop Noise Cancellation Pin	-	-
<b>Others</b>					
C5	PDN	I	Power down Pin "L": Power-down, "H": Power-up	TVDD/ VSS3	TVDD
C4	TESTI1	I	Test Input Pin It must be tied "L".	TVDD/ VSS3	TVDD
D3	TESTO	O	Test Output Pin	AVDD/ VSS1	AVDD
C3	TESTI2	I	Test Input Pin It must be tied "L".	TVDD/ VSS3	TVDD

Note 5. All input pins except analog input pin must not be allowed to float. I/O pin should be connected appropriately.

### ■ Handing of Unused Pins

Unused I/O pins must be connected appropriately.

Classification	Pin Name	Setting
Analog	HPL, HPR, XTO	Open
	XTI	Open (PMOSC bit is fixed to "0")
Digital	TESTO	Open
	MCKI, TESTI1, TESTI2	Connect to VSS3



### 6. Absolute Maximum Ratings

(VSS1 = VSS2 = VSS3 = VSS4 = 0 V; [Note 7](#), [Note 8](#))

Parameter		Symbol	Min.	Max.	Unit
Power Supplies: ( <a href="#">Note 6</a> )	Analog	AVDD	-0.3	4.3	V
	HP-Amp/Charge Pump	CVDD	-0.3	4.3	V
	LDO2 for Digital Core	LVDD	-0.3	4.3	V
	Digital I/F	TVDD	-0.3	4.3	V
Input Current, Any Pin Except Supplies		IIN	-	±10	mA
Analog Input Voltage ( <a href="#">Note 9</a> )		VINA	-0.3	AVDD+0.3 or 4.3	V
Digital Input Voltage ( <a href="#">Note 10</a> )		VIND	-0.3	TVDD+0.3 or 4.3	V
Ambient Temperature (powered applied)		Ta	-40	85	°C
Storage Temperature		Tstg	-65	150	°C

Note 6. Charge pump 1 & 2 are not in operation. In the case that charge pump 1 & 2 are in operation, the maximum values of AVDD and CVDD become 2.15 V.

Note 7. All voltages with respect to ground.

**Note 8. VSS1, VSS2, VSS3 and VSS4 must be connected to the same analog plane.**

Note 9. XTI pin

The maximum value of input voltage is lower value between (AVDD+0.3)V and 4.3V.

Note 10. MCKI, BCLK, LRCK, SDATA, SCL, SDA, PDN, TESTI1, TESTI2 pins

The maximum value of input voltage is lower value between (TVDD+0.3)V and 4.3V.

WARNING: Operation at or beyond these limits may result in permanent damage to the device. Normal Operation is not guaranteed at these extremes.

### 7. Recommended Operating Conditions

(VSS1 = VSS2 = VSS3 = VSS4 = 0 V; [Note 11](#))

Parameter		Symbol	Min.	Typ.	Max.	Unit
Power supplies ( <a href="#">Note 12</a> )	Analog	AVDD	1.7	1.8	1.9	V
	HP-Amp / Charge Pump	CVDD	1.7	1.8	1.9	V
	LDO2 for Digital Core	LVDD	1.7	1.8	1.9	V
	Digital I/F	TVDD	1.65	1.8	3.6	V

Note 11. All voltages with respect to ground.

Note 12. Each power up/down sequence is shown below.

<Power-up>

1. PDN pin = "L"
2. TVDD, AVDD, LVDD, CVDD  
(AVDD must be powered up before or at the same time of CVDD. The power-up sequence of TVDD and LVDD is not critical.)
3. The PDN pin is allowed to be "H" after all power supplies are applied and settled.

<Power-down>

1. PDN pin = "L"
2. TVDD, AVDD, LVDD, CVDD  
(CVDD must be powered down before or at the same time of AVDD. The power-down sequence of TVDD and LVDD is not critical.)

<b>8. Electrical Characteristics</b>
--------------------------------------

■ **Analog Characteristics**

(Ta = 25°C; AVDD = CVDD = LVDD = TVDD = 1.8 V; VSS1 = VSS2 = VSS3 = VSS4 = HPGND = 0 V; Signal Frequency = 1 kHz; 24-bit Data; fs = 44.1 kHz, BCLK = 64 fs; Measurement Bandwidth = 20 Hz to 20 kHz; unless otherwise specified)

<High Performance Mode>

Parameter	Min.	Typ.	Max.	Unit	
<b>Stereo DAC Characteristics:</b>					
Resolution	-	-	32	Bit	
<b>Headphone-Amp Characteristics:</b>					
DAC (Stereo) → HPL/HPR pins, OVL/R = 0 dB, HPG = 0 dB, RL = 32Ω					
<b>Output Power</b>					
0 dBFS, RL = 32Ω, HPG = 0 dB, THD+N < -60 dB	-	25	-	mW	
0 dBFS, RL = 32Ω, HPG = -4 dB	-	10	-	mW	
0 dBFS, RL = 16Ω, HPG = 0 dB, THD+N < -60 dB	-	45	-	mW	
-1.5 dBFS, RL = 16Ω, HPG = +2 dB, THD+N < -20 dB	-	60	-	mW	
Output Level (0 dBFS, RL = 32Ω, HPG = -4 dB)	0.52	0.57	0.61	Vrms	
<b>THD+N</b>					
0 dBFS, RL = 32Ω, OVL/R = -4 dB, HPG = 0 dB (Po = 10 mW)	fs = 44.1 kHz BW = 20 kHz	-	-107	-	dB
	fs = 96 kHz BW = 40 kHz	-	-103	-	dB
	fs = 192 kHz BW = 40 kHz	-	-103	-	dB
	fin = 10kHz fs = 44.1kHz BW = 20kHz	-	-104	-	dB
0 dBFS, RL = 32Ω, OVL/R = -10 dB, HPG = 0 dB (Po = 2.5 mW)	fs = 44.1 kHz BW = 20 kHz	-	-100	-90	dB
0 dBFS, RL = 16Ω, OVL/R = -4 dB, HPG = 0 dB (Po = 20 mW)	fs = 44.1 kHz BW = 20 kHz	-	-106	-	dB
-4 dBFS, RL = 600Ω, HPG = +6 dB, (Po = 2.0 mW @ 1.1Vrms)	fs = 44.1 kHz BW = 20 kHz	-	-99	-	dB

Parameter	Min.	Typ.	Max.	Unit		
Dynamic Range -60 dBFS, A-weighted, HPG = 0 dB	108	116	-	dB		
S/N (A-weighted, Noise Gate Enable) Po = 25 mW, HPG = 0 dB (Data = 0 dBFS / "0" Data)	-	125	-	dB		
S/N (A-weighted, Noise Gate Disable) Po = 25 mW, HPG = 0 dB (Data = 0 dBFS / "0" Data)	108	116	-	dB		
Output Noise Level (Noise Gate Enable, A-weighted)	-	-126	-	dBV		
Output Noise Level (Noise Gate Disable, A-weighted, HPG ≤ -14 dB)	-	-125	-	dBV		
Interchannel Isolation 0 dBFS, HPG = -4 dB (Po = 10 mW) External Impedance = 0.01Ω (Note 13) External Impedance = 0.1Ω (Note 13)	80 -	100 80	- -	dB dB		
Interchannel Gain Mismatch	-	0	0.8	dB		
Load Resistance	14.4	32	-	Ω		
Load Capacitance	-	-	1000	pF		
Load Inductance	-	-	0.375	μH		
PSRR (HPG = -4 dB) (Note 14) 217 Hz 1 kHz	- -	85 85	- -	dB dB		
DC-offset (Note 15) HPG = 0 dB HPG = All Gain	-0.25 -0.4	0 0	+0.25 +0.4	mV mV		
<b>Headphone Output Volume Characteristics:</b>						
Gain Setting	-20	-	+6	dB		
Step Width	Gain: +6 to -20 dB		1	2	3	dB

Note 13. Impedance between the HPGND pin and the system ground.

Note 14. PSRR is referred to all power supplies with 100 mVpp sine wave.

Note 15. When there is no gain change and temperature drift after HP-Amp is powered up.

Parameter	Value	Unit
ESD Immunity IEC61000-4-2 Level4, Contact (Note 16)	±8	kV

Note 16. It is measured at the HPL and HPR pins on an evaluation board (AKD4376A-SC Rev.1).

## &lt;Low Power Mode&gt;

Parameter	Min.	Typ.	Max.	Unit		
<b>Headphone-Amp Characteristics:</b>						
DAC(Stereo) → HPL/HPR pins, OVL/R = 0 dB, HPG = 0 dB, R <sub>L</sub> = 32Ω						
Output Power						
0 dBFS, R <sub>L</sub> = 32Ω, HPG = 0 dB, THD+N < -60 dB	-	25	-	mW		
0 dBFS, R <sub>L</sub> = 32Ω, HPG = -4 dB	-	10	-	mW		
0 dBFS, R <sub>L</sub> = 16Ω, HPG = 0 dB, THD+N < -60 dB	-	45	-	mW		
-1.5 dBFS, R <sub>L</sub> = 16Ω, HPG = +2 dB, THD+N < -20 dB	-	60	-	mW		
Output Level (0 dBFS, R <sub>L</sub> = 32Ω, HPG = -4 dB)	0.52	0.57	0.61	Vrms		
THD+N						
0 dBFS, R <sub>L</sub> = 32Ω, HPG = -4 dB (Po = 10 mW)		fs = 44.1 kHz BW = 20 kHz	-	-92	-	dB
0dBFS, R <sub>L</sub> = 16Ω, HPG = -4dB (Po = 20 mW)		fs = 44.1 kHz BW = 20 kHz	-	-92	-	dB
-4dBFS, R <sub>L</sub> = 600Ω, HPG = + 6dB (Po = 2.0 mW @ 1.1 Vrms)		fs = 44.1 kHz BW = 20 kHz	-	-98	-	dB
Dynamic Range (-60 dBFS, A-weighted, HPG = 0 dB, Data = 0 dBFS)	-	113	-	-	-	dB
S/N (A-weighted) Po = 25 mW, HPG = 0 dB (Data = 0 dBFS / "0" Data)	-	113	-	-	-	dB
Interchannel Isolation						
0 dBFS, HPG = -4 dB (Po = 10 mW)						
External Impedance = 0.01Ω (Note 17)	80	100	-	-	-	dB
External Impedance = 0.1Ω (Note 17)	-	80	-	-	-	dB
Interchannel Gain Mismatch	-	0	0.8	-	-	dB
Load Resistance	14.4	32	-	-	-	Ω
Load Capacitance	-	-	1000	-	-	pF
Load Inductance	-	-	0.375	-	-	μH
PSRR (HPG = -4 dB) (Note 18)						
217 Hz	-	85	-	-	-	dB
1 kHz	-	85	-	-	-	dB
DC-offset (Note 19)						
HPG = 0 dB	-0.35	0	+0.35	-	-	mV
HPG = All Gain	-0.5	0	+0.5	-	-	mV
<b>Headphone Output Volume Characteristics:</b>						
Gain Setting	-20	-	+6	-	-	dB
Step Width	Gain: +6 to -20 dB		1	2	3	dB

Note 17. Impedance between the HPGND pin and the system ground.

Note 18. PSRR is referred to all power supplies with 100 mVpp sine wave.

Note 19. When there is no gain change and temperature drift after HP-Amp is powered up.

### ■ PLL Characteristics

(Ta = -40 to 85°C; AVDD = CVDD = LVDD = 1.7 to 1.9 V; TVDD = 1.65 to 3.6 V; unless otherwise specified)

Parameter	Min.	Typ.	Max.	Unit
<b>PLL Characteristics</b>				
Reference Clock (Figure 11)	0.256	-	3.072	MHz
Output Frequency (PLLCLK) (Figure 11)				
44.1 kHz * 256fs * 9	-	101.606	-	MHz
48.0 kHz * 256fs * 9	-	110.592	-	MHz
44.1 kHz * 256fs * 10	-	112.896	-	MHz
48.0 kHz * 256fs * 10	-	122.880	-	MHz
Lock Time	-	-	2	ms

### ■ Charge Pump & LDO Circuit Power-up Time

(Ta = -40 to 85°C; AVDD = CVDD = LVDD = 1.7 to 1.9 V; TVDD = 1.65 to 3.6 V; unless otherwise specified)

Parameter	Capacitor	Min.	Typ.	Max.	Unit
<b>Block power up time</b>					
CP1 (Note 20)	1 μF @ VEE1	-	-	6.5	ms
CP2 (Class-G) (Note 20, Note 21)	2.2 μF @ VEE2	-	-	4.5	ms
LDO1P (Note 22)	1 μF @ RAVDD	-	-	1	ms
LDO1N (Note 22)	1 μF @ RVEE	-	-	1	ms
LDO2 (Note 20)	2.2 μF @ VDD12	-	-	1	ms

Note 20. Power up time is a fixed value that is not affected by a capacitor.

Note 21. Power up time is a value to -1/2CVDD, since CP2 starts with 1/2 VDD Mode as part of Class-G operation.

Note 22. Power-up time is proportional to a capacitor value.

For instance, if a 2.2 μF capacitor is connected to the RVEE pin, LDO1N power-up time is 2.2ms (max.).

### ■ Power Supply Current

(Ta = 25°C; AVDD = CVDD = LVDD = TVDD = 1.8 V; VSS1 = VSS2 = VSS3 = VSS4 = HPGND = 0 V, BCLK = 64fs; Slave Mode, No Data input, RL = 32Ω; unless otherwise specified)

Parameter	Min.	Typ.	Max.	Unit
<b>Power Supply Current:</b>				
Power Up (PDN pin = "H", All Circuits Power-up) (Note 23)				
AVDD+ CVDD + LVDD + TVDD	-	23	-	mA
Power Up (PDN pin = "H", DAC+HP-amp Power-Up, PLL & X'tal OSC Power Down) (Note 24)				
AVDD+ CVDD + LVDD + TVDD	-	20	30	mA
Power Down (PDN pin = "L")				
AVDD + CVDD + LVDD + TVDD	-	0	10	μA

Note 23. DAC, HP-Amp, PLL and X'tal OSC are all powered up.

Note 24. All digital input pins are fixed to TVDD or VSS3.

### ■ Power Consumptions for Each Operation Mode

(Ta = 25°C; AVDD = CVDD = LVDD = TVDD = 1.8 V; VSS1 = VSS2 = VSS3 = VSS4 = 0 V; MCKI = 256fs, BCLK = 64fs; Slave Mode, No data input, RL = 32Ω, X'tal OSC Power-down)

<High Performance Mode>

	AVDD [mA]	CVDD [mA]	LVDD [mA]	TVDD [mA]	Total Power [mW]
DAC → HP (fs = 44.1 kHz)	8.38	11.34	0.47	0.02	36.32
DAC → HP (fs = 96 kHz)	8.38	11.34	0.57	0.02	36.55
DAC → HP (fs = 192 kHz)	8.38	11.34	0.62	0.02	36.64

<Low Power Mode>

	AVDD [mA]	CVDD [mA]	LVDD [mA]	TVDD [mA]	Total Power [mW]
DAC → HP (fs = 44.1 kHz)	3.23	4.03	0.36	0.02	13.75

### ■ DAC Sharp Roll-Off Filter (fs = 44.1 kHz)

(Ta = -40 to 85°C; AVDD = CVDD = LVDD = 1.7 to 1.9 V; TVDD = 1.65 to 3.6 V; fs = 44.1 kHz; DASD bit = "0", DASL bit = "0")

Parameter	Symbol	Min.	Typ.	Max.	Unit		
<b>DAC Digital Filter(LPF):</b>							
Passband (Note 25)		-0.006 to +0.124 dB	PB	0	-	20.42	kHz
		-6.0 dB		-	22.05	-	kHz
Stopband (Note 25)	SB	24.1	-	-	-	-	kHz
Passband Ripple	PR	-0.006	-	-	+0.124	-	dB
Stopband Attenuation (Note 26)	SA	69.9	-	-	-	-	dB
Group Delay (Note 27)	GD	-	-	26	-	-	1/fs
<b>DAC Digital Filter (LPF) + DACANA (Headphone-Amp) @ High performance mode :</b>							
Frequency Response: 0 to 20.0 kHz	FR	-0.12	-	-	+0.03	-	dB
<b>DAC Digital Filter (LPF) + DACANA (Headphone-Amp) @ Low power mode :</b>							
Frequency Response: 0 to 20.0 kHz	FR	-0.68	-	-	+0.03	-	dB

Note 25. The passband and stopband frequencies scale with fs (system sampling rate).

PB = 0.4630 x fs (@-0.006 /+0.124 dB), SB = 0.5465 x fs. Each frequency response refers to that of 1 kHz.

Note 26. The bandwidth of the stopband attenuation value is from stopband to fs (system sampling rate).

Note 27. The calculated delay time is resulting from digital filtering. This is the time from the input of MSB for Lch of SDATA to the output of an analog signal. The error of the delay at audio interface is within +1 [1/fs].

### ■ DAC Sharp Roll-Off Filter (fs = 96 kHz)

(Ta = -40 to 85°C; AVDD = CVDD = LVDD = 1.7 to 1.9 V; TVDD = 1.65 to 3.6 V; fs = 96 kHz; DASD bit = "0", DASL bit = "0")

Parameter	Symbol	Min.	Typ.	Max.	Unit		
<b>DAC Digital Filter(LPF):</b>							
Passband (Note 28)		-0.003 to +0.127 dB	PB	0	-	44.4	kHz
		-6.0 dB		-	48.01	-	kHz
Stopband (Note 28)	SB	52.5	-	-	-	-	kHz
Passband Ripple	PR	-0.003	-	-	+0.127	-	dB
Stopband Attenuation (Note 29)	SA	69.9	-	-	-	-	dB
Group Delay (Note 30)	GD	-	-	26	-	-	1/fs
<b>DAC Digital Filter (LPF) + DACANA (Headphone-Amp) @ High performance mode :</b>							
Frequency Response: 0 to 40.0 kHz	FR	-0.72	-	-	+0.11	-	dB
<b>DAC Digital Filter (LPF) + DACANA (Headphone-Amp) @ Low power mode :</b>							
Frequency Response: 0 to 40.0 kHz	FR	-2.18	-	-	+0.10	-	dB

Note 28. The passband and stopband frequencies scale with fs (system sampling rate).

PB = 0.4625 x fs (@-0.003/+0.127 dB), SB = 0.547 x fs. Each frequency response refers to that of 1 kHz.

Note 29. The bandwidth of the stopband attenuation value is from stopband to fs (system sampling rate).

Note 30. The calculated delay time is resulting from digital filtering. This is the time from the input of MSB for Lch of SDATA to the output of an analog signal. The error of the delay at audio interface is within +1 [1/fs].

### ■ DAC Sharp Roll-Off Filter (fs = 192 kHz)

(Ta = -40 to 85°C; AVDD = CVDD = LVDD = 1.7 to 1.9 V; TVDD = 1.65 to 3.6 V; fs = 192 kHz; DASD bit = "0", DASL bit = "0")

Parameter		Symbol	Min.	Typ.	Max.	Unit
<b>DAC Digital Filter(LPF):</b>						
Passband (Note 31)	-0.002 to +0.13 dB	PB	0	-	88.94	kHz
	-6.0 dB		-	96.01	-	kHz
Stopband (Note 31)		SB	105	-	-	kHz
Passband Ripple		PR	-0.002	-	+0.13	dB
Stopband Attenuation (Note 32)		SA	69.9	-	-	dB
Group Delay (Note 33)		GD	-	26	-	1/fs
<b>DAC Digital Filter (LPF) + DACANA (Headphone-Amp) @ High performance mode :</b>						
Frequency Response: 0 to 80.0 kHz		FR	-2.90	-	+0.35	dB
<b>DAC Digital Filter (LPF) + DACANA (Headphone-Amp) @ Low power mode :</b>						
Frequency Response: 0 to 80.0 kHz		FR	-6.42	-	+0.35	dB

Note 31. The passband and stopband frequencies scale with fs (system sampling rate).

PB = 0.4538 x fs (@-0.002/+0.13 dB), SB = 0.5469 x fs. Each frequency response refers to that of 1 kHz.

Note 32. The bandwidth of the stopband attenuation value is from stopband to fs (system sampling rate).

Note 33. The calculated delay time is resulting from digital filtering. This is the time from the input of MSB for Lch of SDATA to the output of an analog signal. The error of the delay at audio interface is within +1 [1/fs].



### ■ DAC Slow Roll-Off Filter (fs = 44.1 kHz)

(Ta = -40 to 85°C; AVDD = CVDD = LVDD = 1.7 to 1.9 V; TVDD = 1.65 to 3.6 V; fs = 44.1 kHz; DASD bit = "0", DASL bit = "1")

Parameter	Symbol	Min.	Typ.	Max.	Unit	
<b>DAC Digital Filter(LPF):</b>						
Passband (Note 34)	-0.07 to +0.006 dB -3.0 dB	PB	0	-	7.7	kHz
			-	18.34	-	kHz
Stopband (Note 34)		SB	39.1	-	-	kHz
Passband Ripple		PR	-0.07	-	+0.006	dB
Stopband Attenuation (Note 35)		SA	72.8	-	-	dB
Group Delay (Note 36)		GD	-	26	-	1/fs
<b>DAC Digital Filter (LPF) + DACANA (Headphone-Amp) @ High performance mode :</b>						
Frequency Response: 0 to 20.0 kHz		FR	-4.44	-	+0.03	dB
<b>DAC Digital Filter (LPF) + DACANA (Headphone-Amp) @ Low power mode :</b>						
Frequency Response: 0 to 20.0 kHz		FR	-5.00	-	+0.03	dB

Note 34. The passband and stopband frequencies scale with fs (system sampling rate).

PB =  $0.1746 \times fs$  (@-0.07/+0.006 dB), SB =  $0.887 \times fs$ . Each frequency response refers to that of 1 kHz.

Note 35. The bandwidth of the stopband attenuation value is from stopband to fs (system sampling rate).

Note 36. The calculated delay time is resulting from digital filtering. This is the time from the input of MSB for Lch of SDATA to the output of an analog signal. The error of the delay at audio interface is within +1 [1/fs].

### ■ DAC Slow Roll-Off Filter (fs = 96 kHz)

(Ta = -40 to 85°C; AVDD = CVDD = LVDD = 1.7 to 1.9 V; TVDD = 1.65 to 3.6 V; fs = 96 kHz; DASD bit = "0", DASL bit = "1")

Parameter	Symbol	Min.	Typ.	Max.	Unit	
<b>DAC Digital Filter (LPF):</b>						
Passband (Note 37)	-0.07 to +0.007 dB -3.0 dB	PB	0	-	16.76	kHz
			-	39.9	-	kHz
Stopband (Note 37)		SB	85.2	-	-	kHz
Passband Ripple		PR	-0.07	-	+0.007	dB
Stopband Attenuation (Note 38)		SA	72.8	-	-	dB
Group Delay (Note 39)		GD	-	26	-	1/fs
<b>DAC Digital Filter (LPF) + DACANA (Headphone-Amp) @ High performance mode:</b>						
Frequency Response: 0 to 40.0 kHz		FR	-4.00	-	+0.10	dB
<b>DAC Digital Filter (LPF) + DACANA (Headphone-Amp) @ Low power mode:</b>						
Frequency Response: 0 to 40.0 kHz		FR	-5.46	-	+0.10	dB

Note 37. The passband and stopband frequencies scale with fs (system sampling rate).

PB =  $0.1746 \times fs$  (@-0.07/+0.007 dB), SB =  $0.887 \times fs$ . Each frequency response refers to that of 1 kHz.

Note 38. The bandwidth of the stopband attenuation value is from stopband to fs (system sampling rate).

Note 39. The calculated delay time is resulting from digital filtering. This is the time from the input of MSB for Lch of SDATA to the output of an analog signal. The error of the delay at audio interface is within +1 [1/fs].

### ■ DAC Slow Roll-Off Filter (fs = 192 kHz)

(Ta = -40 to 85°C; AVDD = CVDD = LVDD = 1.7 to 1.9 V; TVDD = 1.65 to 3.6 V; fs = 192 kHz; DASD bit = "0", DASL bit = "1")

Parameter	Symbol	Min.	Typ.	Max.	Unit	
<b>DAC Digital Filter (LPF):</b>						
Passband (Note 40)	-0.07 to +0.007 dB	PB	0	-	33.56	kHz
	-3.0 dB		-	79.9	-	kHz
Stopband (Note 40)		SB	170.3	-	-	kHz
Passband Ripple		PR	-0.07	-	+0.007	dB
Stopband Attenuation (Note 41)		SA	72.8	-	-	dB
Group Delay (Note 42)		GD	-	26	-	1/fs
<b>DAC Digital Filter (LPF) + DACANA (Headphone-Amp) @ High performance mode :</b>						
Frequency Response: 0 to 80.0 kHz		FR	-6.00	-	+0.35	dB
<b>DAC Digital Filter (LPF) + DACANA (Headphone-Amp) @ Low power mode :</b>						
Frequency Response: 0 to 80.0 kHz		FR	-9.47	-	+0.35	dB

Note 40. The passband and stopband frequencies scale with fs (system sampling rate).

PB =  $0.1748 \times fs$  (@-0.07/+0.007 dB), SB =  $0.887 \times fs$ . Each frequency response refers to that of 1 kHz.

Note 41. The bandwidth of the stopband attenuation value is from stopband to fs (system sampling rate).

Note 42. The calculated delay time is resulting from digital filtering. This is the time from the input of MSB for Lch of SDATA to the output of an analog signal. The error of the delay at audio interface is within +1 [1/fs].

### ■ DAC Short Delay Sharp Roll-Off Filter (fs = 44.1 kHz)

(Ta = -40 to 85°C; AVDD = CVDD = LVDD = 1.7 to 1.9 V; TVDD = 1.65 to 3.6 V; fs = 44.1 kHz; DASD bit = "1", DASL bit = "0")

Parameter		Symbol	Min.	Typ.	Max.	Unit
<b>DAC Digital Filter (LPF):</b>						
Passband (Note 43)	-0.008 to +0.126 dB	PB	0	-	20.4	kHz
	-6.0 dB		-	22.18	-	kHz
Stopband (Note 43)		SB	24.1	-	-	kHz
Passband Ripple		PR	-0.008	-	+0.126	dB
Stopband Attenuation (Note 44)		SA	56.4	-	-	dB
Group Delay (Note 45)		GD	-	5.5	-	1/fs
<b>DAC Digital Filter (LPF) + DACANA (Headphone-Amp) @ High performance mode :</b>						
Frequency Response: 0 to 20.0 kHz		FR	-0.12	-	+0.03	dB
<b>DAC Digital Filter (LPF) + DACANA (Headphone-Amp) @ Low power mode :</b>						
Frequency Response: 0 to 20.0 kHz		FR	-0.68	-	+0.03	dB

Note 43. The passband and stopband frequencies scale with fs (system sampling rate).

PB =  $0.4626 \times fs$  (@-0.008/+0.126 dB), SB =  $0.5465 \times fs$ . Each frequency response refers to that of 1 kHz.

Note 44. The bandwidth of the stopband attenuation value is from stopband to fs (system sampling rate).

Note 45. The calculated delay time is resulting from digital filtering. This is the time from the input of MSB for Lch of SDATA to the output of an analog signal. The error of the delay at audio interface is within +1 [1/fs].

### ■ DAC Short Delay Sharp Roll-Off Filter (fs = 96 kHz)

(Ta = -40 to 85°C; AVDD = CVDD = LVDD = 1.7 to 1.9 V; TVDD = 1.65 to 3.6 V; fs = 96 kHz; DASD bit = "1", DASL bit = "0")

Parameter		Symbol	Min.	Typ.	Max.	Unit
<b>DAC Digital Filter (LPF):</b>						
Passband (Note 46)	-0.003 to +0.132dB	PB	0	-	44.4	kHz
	-6.0 dB		-	48.28	-	kHz
Stopband (Note 46)		SB	52.5	-	-	kHz
Passband Ripple		PR	-0.003	-	+0.132	dB
Stopband Attenuation (Note 47)		SA	56.4	-	-	dB
Group Delay (Note 48)		GD	-	5.5	-	1/fs
<b>DAC Digital Filter (LPF) + DACANA (Headphone-Amp) @ High performance mode:</b>						
Frequency Response: 0 to 40.0 kHz		FR	-0.90	-	+0.11	dB
<b>DAC Digital Filter (LPF) + DACANA (Headphone-Amp) @ Low power mode:</b>						
Frequency Response: 0 to 40.0 kHz		FR	-2.36	-	+0.10	dB

Note 46. The passband and stopband frequencies scale with fs (system sampling rate).

PB =  $0.4625 \times fs$  (@-0.003/+0.132 dB), SB =  $0.5465 \times fs$ . Each frequency response refers to that of 1 kHz.

Note 47. The bandwidth of the stopband attenuation value is from stopband to fs (system sampling rate).

Note 48. The calculated delay time is resulting from digital filtering. This is the time from the input of MSB for Lch of SDATA to the output of an analog signal. The error of the delay at audio interface is within +1 [1/fs].

### ■ DAC Short Delay Sharp Roll-Off Filter (fs = 192 kHz)

(Ta = -40 to 85°C; AVDD = CVDD = LVDD = 1.7 to 1.9 V; TVDD = 1.65 to 3.6 V; fs = 192 kHz; DASD bit = "1", DASL bit = "0")

Parameter	Symbol	Min.	Typ.	Max.	Unit	
<b>DAC Digital Filter (LPF):</b>						
Passband (Note 49)	-0.001 to +0.135 dB	PB	0	-	88.8	kHz
	-6.0 dB		-	96.57	-	kHz
Stopband (Note 49)		SB	105	-	-	kHz
Passband Ripple		PR	-0.001	-	+0.135	dB
Stopband Attenuation (Note 50)		SA	56.4	-	-	dB
Group Delay (Note 51)		GD	-	5.5	-	1/fs
<b>DAC Digital Filter (LPF) + DACANA (Headphone-Amp) @ High performance mode :</b>						
Frequency Response: 0 to 80.0 kHz		FR	-3.00	-	+0.36	dB
<b>DAC Digital Filter (LPF) + DACANA (Headphone-Amp) @ Low power mode :</b>						
Frequency Response: 0 to 80.0 kHz		FR	-6.52	-	+0.35	dB

Note 49. The passband and stopband frequencies scale with fs (system sampling rate).

PB =  $0.4625 \times fs$  (@ -0.001/+0.135 dB), SB =  $0.5469 \times fs$ . Each frequency response refers to that of 1 kHz.

Note 50. The bandwidth of the stopband attenuation value is from stopband to fs (system sampling rate).

Note 51. The calculated delay time is resulting from digital filtering. This is the time from the input of MSB for Lch of SDATA to the output of an analog signal. The error of the delay at audio interface is within +1 [1/fs].

### ■ DAC Short Delay Slow Roll-Off Filter (fs = 44.1 kHz)

(Ta = -40 to 85°C; AVDD = CVDD = LVDD = 1.7 to 1.9 V; TVDD = 1.65 to 3.6 V; fs = 44.1 kHz; DASD bit = "1", DASL bit = "1")

Parameter	Symbol	Min.	Typ.	Max.	Unit		
<b>DAC Digital Filter (LPF):</b>							
Passband (Note 52)		-0.07 to +0.025 dB	PB	0	-	8.83	kHz
		-3.0 dB		-	18.72	-	kHz
Stopband (Note 52)	SB	39.5	-	-	-	kHz	
Passband Ripple	PR	-0.07	-	+0.025	-	dB	
Stopband Attenuation (Note 53)	SA	75.1	-	-	-	dB	
Group Delay (Note 54)	GD	-	4.7	-	-	1/fs	
<b>DAC Digital Filter (LPF) + DACANA (Headphone-Amp) @ High performance mode :</b>							
Frequency Response: 0 to 20.0 kHz	FR	-4.16	-	+0.05	-	dB	
<b>DAC Digital Filter (LPF) + DACANA (Headphone-Amp) @ Low power mode :</b>							
Frequency Response: 0 to 20.0 kHz	FR	-4.66	-	+0.03	-	dB	

Note 52. The passband and stopband frequencies scale with fs (system sampling rate).

PB =  $0.2002 \times fs$  (@ -0.07/+0.025 dB), SB =  $0.8957 \times fs$ . Each frequency response refers to that of 1 kHz.

Note 53. The bandwidth of the stopband attenuation value is from stopband to fs (system sampling rate).

Note 54. The calculated delay time is resulting from digital filtering. This is the time from the input of MSB for Lch of SDATA to the output of an analog signal. The error of the delay at audio interface is within +1 [1/fs].

### ■ DAC Short Delay Slow Roll-Off Filter (fs = 96 kHz)

(Ta = -40 to 85°C; AVDD = CVDD = LVDD = 1.7 to 1.9 V; TVDD = 1.65 to 3.6 V; fs = 96 kHz; DASD bit = "1", DASL bit = "1")

Parameter	Symbol	Min.	Typ.	Max.	Unit		
<b>DAC Digital Filter (LPF):</b>							
Passband (Note 55)		-0.07 to +0.027 dB	PB	0	-	19.29	kHz
		-3.0 dB		-	40.78	-	kHz
Stopband (Note 55)	SB	86	-	-	-	kHz	
Passband Ripple	PR	-0.07	-	+0.027	-	dB	
Stopband Attenuation (Note 56)	SA	75.1	-	-	-	dB	
Group Delay (Note 57)	GD	-	4.7	-	-	1/fs	
<b>DAC Digital Filter (LPF) + DACANA (Headphone-Amp) @ High performance mode :</b>							
Frequency Response: 0 to 40.0 kHz	FR	-3.80	-	+0.10	-	dB	
<b>DAC Digital Filter (LPF) + DACANA (Headphone-Amp) @ Low power mode :</b>							
Frequency Response: 0 to 40.0 kHz	FR	-5.26	-	+0.10	-	dB	

Note 55. The passband and stopband frequencies scale with fs (system sampling rate).

PB =  $0.2009 \times fs$  (@ -0.07/+0.027 dB), SB =  $0.8958 \times fs$ . Each frequency response refers to that of 1 kHz.

Note 56. The bandwidth of the stopband attenuation value is from stopband to fs (system sampling rate).

Note 57. The calculated delay time is resulting from digital filtering. This is the time from the input of MSB for Lch of SDATA to the output of an analog signal. The error of the delay at audio interface is within +1 [1/fs].

### ■ DAC Short Delay Slow Roll-Off Filter (fs = 192 kHz)

(Ta = -40 to 85°C; AVDD = CVDD = LVDD = 1.7 to 1.9 V; TVDD = 1.65 to 3.6 V; fs = 192 kHz; DASD bit = "1", DASL bit = "1")

Parameter		Symbol	Min.	Typ.	Max.	Unit
<b>DAC Digital Filter (LPF):</b>						
Passband (Note 58)	-0.07 to +0.027 dB	PB	0	-	38.63	kHz
	-3.0 dB		-	81.57	-	kHz
Stopband (Note 58)		SB	172	-	-	kHz
Passband Ripple		PR	-0.07	-	+0.027	dB
Stopband Attenuation (Note 59)		SA	75.1	-	-	dB
Group Delay (Note 60)		GD	-	4.7	-	1/fs
<b>DAC Digital Filter (LPF) + DACANA (Headphone-Amp) @ High performance mode:</b>						
Frequency Response: 0 to 80.0 kHz		FR	-5.90	-	+0.35	dB
<b>DAC Digital Filter (LPF) + DACANA (Headphone-Amp) @ Low power mode:</b>						
Frequency Response: 0 to 80.0 kHz		FR	-9.38	-	+0.35	dB

Note 58. The passband and stopband frequencies scale with fs (system sampling rate).

PB =  $0.2012 \times fs$  (@ -0.07/+0.027 dB), SB =  $0.8958 \times fs$ . Each frequency response refers to that of 1 kHz.

Note 59. The bandwidth of the stopband attenuation value is from stopband to fs (system sampling rate).

Note 60. The calculated delay time is resulting from digital filtering. This is the time from the input of MSB for Lch of SDATA to the output of an analog signal. The error of the delay at audio interface is within +1 [1/fs].

### ■ DC Characteristics

(Ta = -40 to 85°C; AVDD = CVDD = LVDD = 1.7 to 1.9 V; TVDD = 1.65 to 3.6 V)

Parameter	Symbol	Min.	Typ.	Max.	Unit
<b>I/O Pins (Note 61)</b>					
High-Level Input Voltage					
Except for XTI pin	V <sub>IH</sub>	70 %TVDD	-	-	V
XTI pin	V <sub>IH</sub>	70 %AVDD	-	-	V
Low-Level Input Voltage					
Except for XTI pin	V <sub>IL</sub>	-	-	30 %TVDD	V
XTI pin	V <sub>IL</sub>	-	-	30 %AVDD	V
High-Level Output Voltage (I <sub>out</sub> = -200 μA)	V <sub>OH</sub>	TVDD -0.2	-	-	V
Low-Level Output Voltage					
Except for SDA, XTO pin, I <sub>out</sub> = 200 μA	V <sub>OL</sub>	-	-	0.2	V
SDA pin					
2 V < TVDD ≤ 3.6 V (I <sub>out</sub> = 3 mA)	V <sub>OL</sub>	-	-	0.4	V
1.65 V ≤ TVDD ≤ 2 V (I <sub>out</sub> = 2 mA)	V <sub>OL</sub>	-	-	20 %TVDD	V
Input Leakage Current	I <sub>in</sub>	-5	-	+5	μA

Note 61. MCKI, BCLK, LRCK, SDATA, SCL, SDA, PDN, TESTI1, TESTO, TESTI2 pins

### ■ Switching Characteristics

(Ta = -40 to 85°C; AVDD = CVDD = LVDD = 1.7 to 1.9 V; TVDD = 1.65 to 3.6 V; CL = 80 pF; unless otherwise specified)

Parameter	Symbol	Min.	Typ.	Max.	Unit
<b>MCKI</b>					
Input Frequency	fMCK	0.256	-	28.8	MHz
Pulse Width Low	tMCKL	0.4 / fMCK	-	-	ns
Pulse Width High	tMCKH	0.4 / fMCK	-	-	ns
<b>X'tal Oscillator (XTI pin)</b>					
Input Frequency	fMCK	11.2896	-	24.576	MHz
<b>Audio Interface Timing</b>					
<b>Master Mode</b>					
LRCK Output Timing					
Frequency (Note 62)	fs	8	-	192	kHz
Pulse Width High	Duty	-	50	-	%
BCLK Output Timing					
Period (BCKO bit = "0")	tBCK	-	1/(64fs)	-	ns
(BCKO bit = "1")	tBCK	-	1/(32fs)	-	ns
Duty	Duty	-	50	-	%
BCLK "↓" to LRCK Edge	tBSYD	-20	-	20	ns
SDATA Hold Time	tBIDS	10	-	-	ns
SDATA Setup Time	tBIDH	10	-	-	ns
<b>Slave Mode</b>					
LRCK Input Timing					
Frequency	fs	8	-	384	kHz
Pulse Width High	tLRCKH	45	50	55	%
BCLK Input Timing					
Period (Note 63)	tBCK	0.256	-	24.576 or 512fs	MHz
Pulse Width Low	tBCKL	0.4 x tBCK	-	-	ns
Pulse Width High	tBCKH	0.4 x tBCK	-	-	ns
BCLK "↑" to LRCK Edge	tBSYD	16	-	-	ns
LRCK Edge to BCLK "↑"	tSYBD	16	-	-	ns
SDATA Hold Time	tBIDS	10	-	-	ns
SDATA Setup Time	tBIDH	10	-	-	ns

Note 62. Supported sampling rates are 8 k, 11.025 k, 12 k, 16 k, 22.05 k, 24 k, 32 k, 44.1 k, 48 k, 64 k, 88.2 k, 96 k, 176.4 k and 192 kHz

Note 63. The maximum value is shorter period between "24.576 MHz" and "512fs".



Parameter	Symbol	Min.	Typ.	Max.	Unit
<b>Control Interface Timing (I<sup>2</sup>C Bus mode): (Note 64)</b>					
SCL Clock Frequency	fSCL	-	-	400	kHz
Bus Free Time Between Transmissions	tBUF	1.3	-	-	μs
Start Condition Hold Time (prior to first clock pulse)	tHD:STA	0.6	-	-	μs
Clock Low Time	tLOW	1.3	-	-	μs
Clock High Time	tHIGH	0.6	-	-	μs
Setup Time for Repeated Start Condition	tSU:STA	0.6	-	-	μs
SDA Hold Time from SCL Falling (Note 65)	tHD:DAT	0	-	-	μs
SDA Setup Time from SCL Rising	tSU:DAT	0.1	-	-	μs
Rise Time of Both SDA and SCL Lines	tR	-	-	0.3	μs
Fall Time of Both SDA and SCL Lines	tF	-	-	0.3	μs
Setup Time for Stop Condition	tSU:STO	0.6	-	-	μs
Capacitive Load on Bus	Cb	-	-	400	pF
Pulse Width of Spike Noise Suppressed by Input Filter	tSP	0	-	50	ns
<b>Power-down &amp; Reset Timing</b>					
PDN accept pulse width (Note 66)	tPDN	1	-	-	ms
PDN Reject Pulse Width (Note 66)	tRPD	-	-	50	ns

Note 64. I<sup>2</sup>C-bus is a registered trademark of NXP B.V.

Note 65. Data must be held long enough to bridge the 300ns-transition time of SCL.

Note 66. The AK4376A will be reset by the PDN pin = "L" for tPDN (Min.). The PDN pin must held "L" for longer period than or equal to tPDN (Min.). The AK4376A will not be reset by the "L" pulse shorter than or equal to tRPD (Max.).

■ Timing Diagram (System Clock)

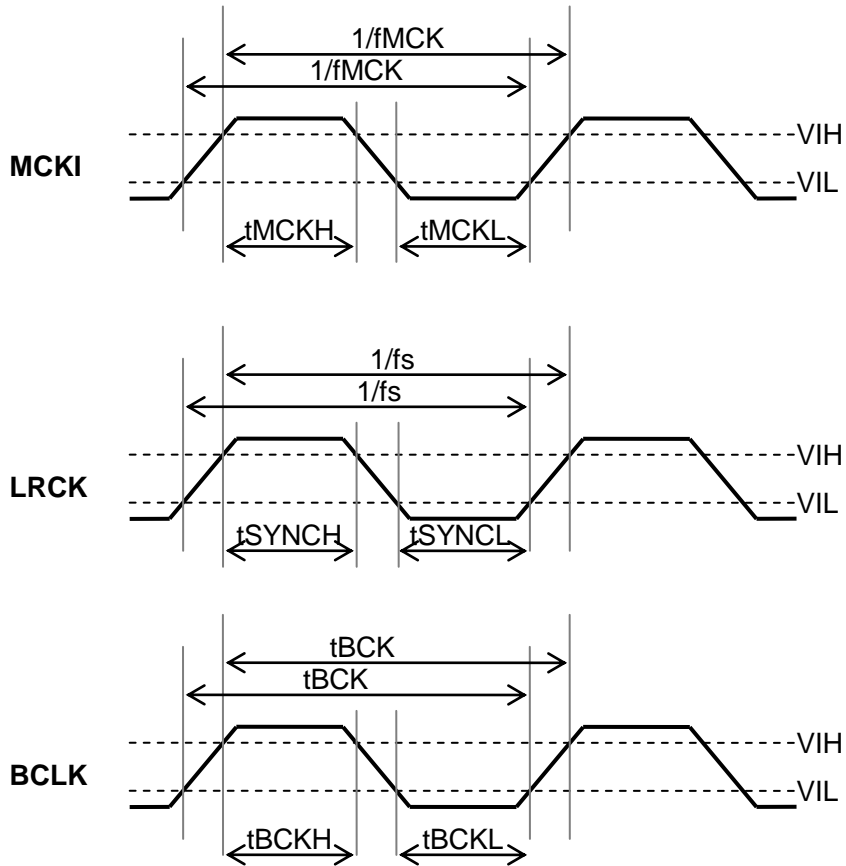

Figure 2. System Clock (Slave Mode)

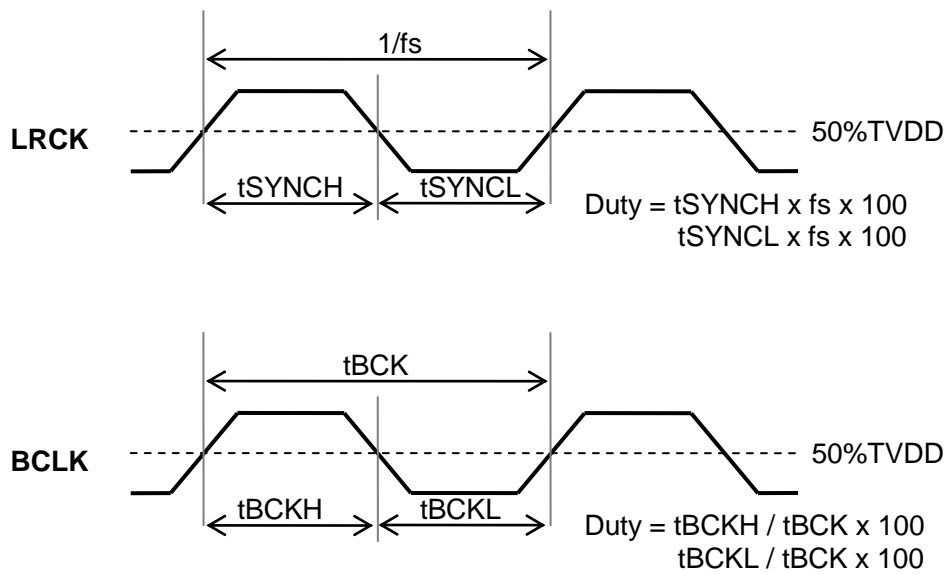

Figure 3. System Clock (Master Mode)

■ Timing Diagram (Serial Audio I/F)

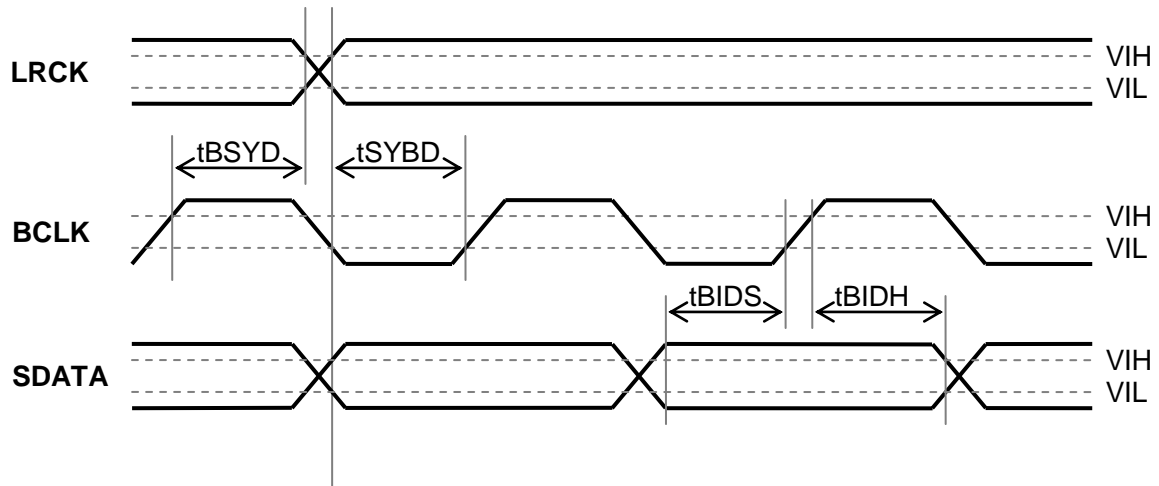

Figure 4. Serial Data Interface (Slave Mode)

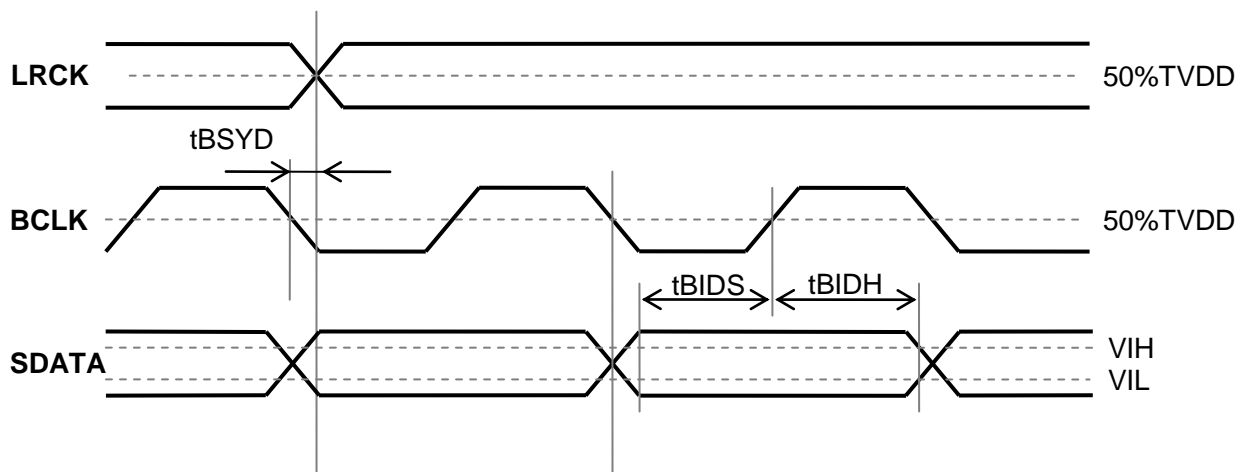

Figure 5. Serial Data Interface (Master Mode)

■ Timing Diagram (I<sup>2</sup>C Interface)

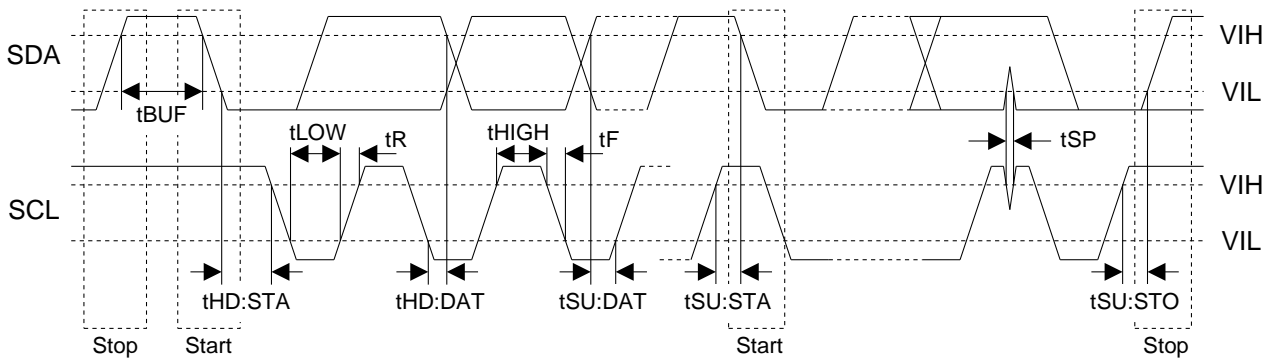

Figure 6. I<sup>2</sup>C Bus Mode Timing

■ Timing Diagram (Reset)

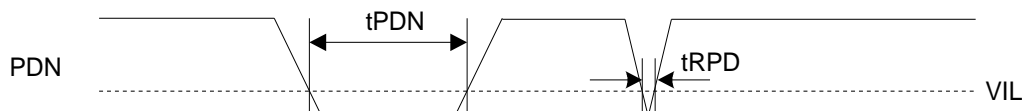

Figure 7. Power Down and Standby

**9. Functional Description**

**■ System Clock**

The AK4376A is operated by a clock generated by PLL or an externally input clock or X'tal oscillator (XTI pin). DACCKS[1:0] bits select the clock source of the DAC (Table 1). PLL clock source is selected from external MCKI, BCLK or the clock by X'tal oscillator (Table 7). Master clock frequency and sampling frequency are set by CM[1:0] bits and FS[4:0] bits, respectively. PMDA, PMHPL and PMHPR bits must be set to "0" when changing these frequencies.

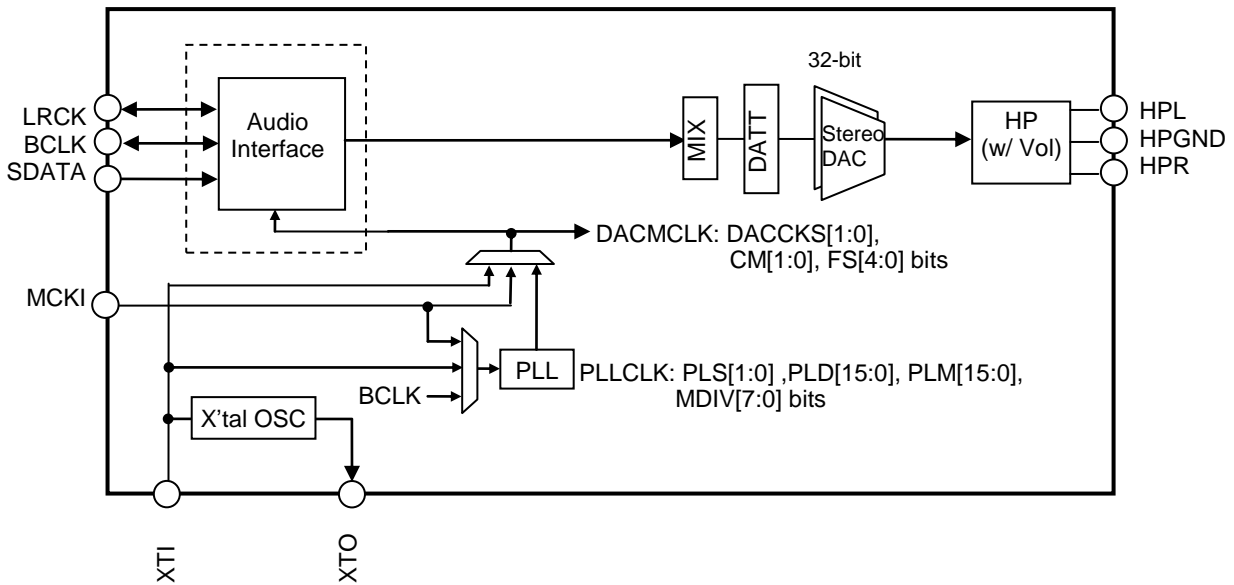

Figure 8. Clock & Data Flow

Table 1. DAC Master Clock Setting (x: Do not care)

DACCKS[1:0] bits	DAC Master Clock
00	MCKI pin
01	PLLCLK
1x	X'tal (or XTI pin)

(default)

The AK4376A can be operated in both master and slave modes. Clock mode of LRCK pin and BCLK pin can be selected by MS bit. When using master mode, the LRCK pin and the BCLK pin should be pulled down or pulled up with an external resistor (about 100 kΩ) because both pins are floating state until MS bit becomes "1".

Table 2. Master/Slave Mode Select

MS bit	LRCK pin, BCLK pin
0	Slave Mode
1	Master Mode

 (default)

Master/slave mode switching is not allowed while the AK4376A is in normal operation. The DAC and Headphone-Amp must be powered down before master/slave mode is switched. Furthermore PLL and Charge Pump must also be powered down in case that sampling frequency is changed or PLLCLK is stopped.

<MS bit Setting Sequence Example>

- 1.DAC, Headphone-Amp (PLL, Charge Pump) Power-down
- 2.Clock Mode of ACPU Setting (In case clock mode of ACPU is master, switch to slave.)
- 3.MS bit Selection
- 4.Clock Mode of ACPU Setting (In case clock mode of ACPU is slave, switch to master.)
- 5.DAC, Headphone-Amp (PLL, Charge Pump) Power-up

Figure 9 shows clock & data flow in slave mode. Figure 10 shows clock & data flow in master mode.

<Slave Mode>

MS bit = "0", PMPLL bit = "0", DACCKS[1:0] bits = "00"

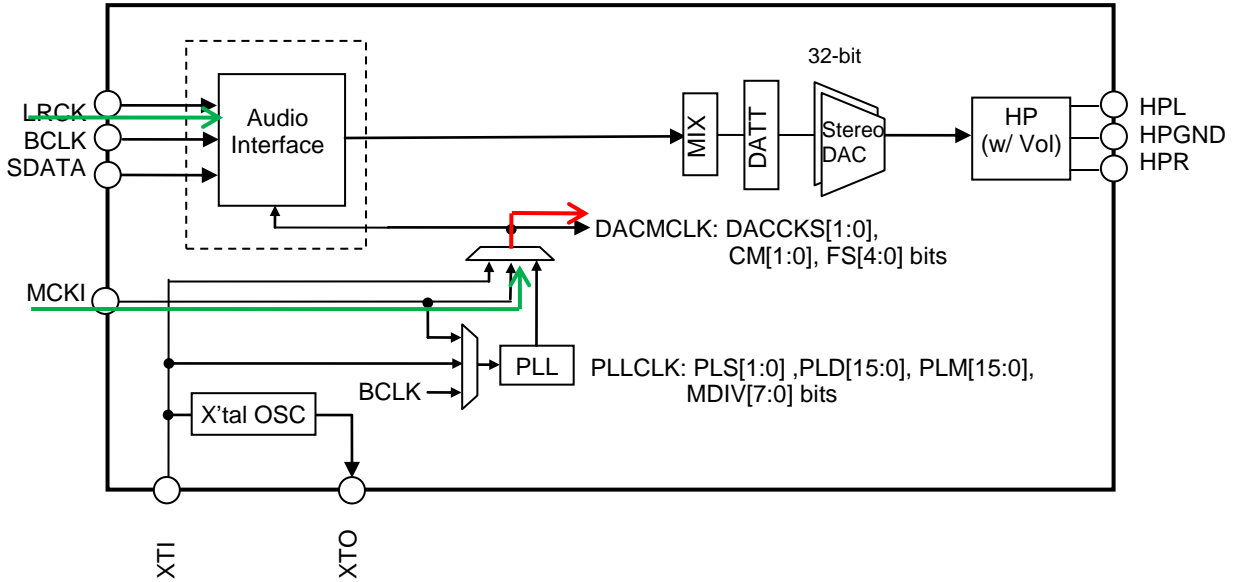

Figure 9. Example of Clock and Data Flow (Slave Mode, Not using PLL)

<Master Mode>

MS bit = "1", PMPLL bit = "1", PLS[1:0] bits = "00", DACCKS[1:0] bits = "01"

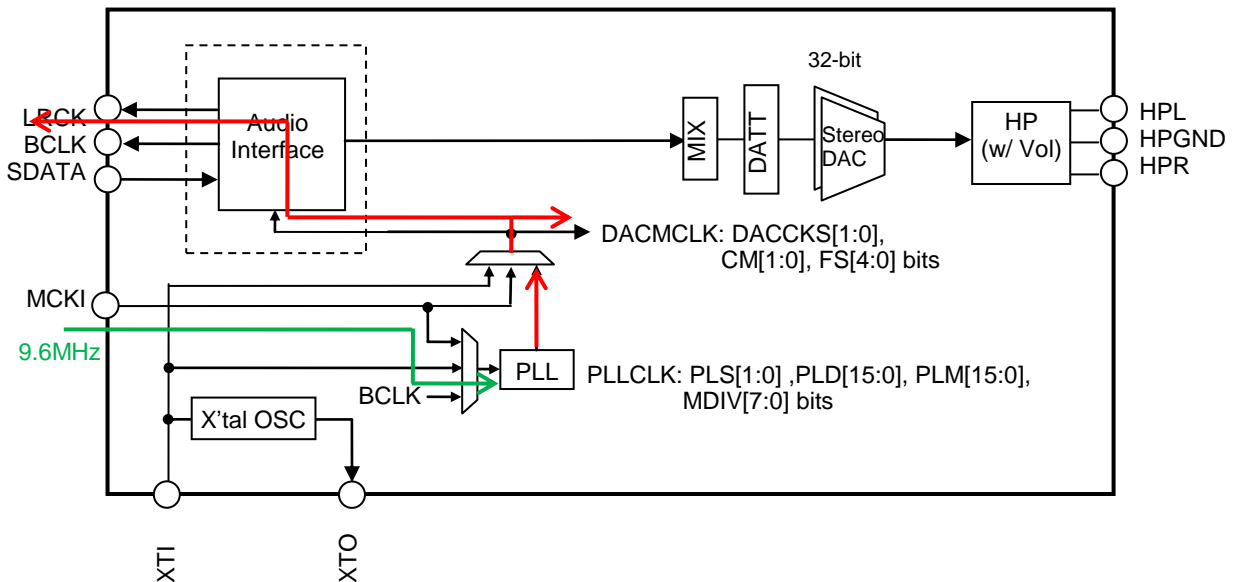

Figure 10. Example of Clock and Data Flow (Master Mode, Using PLL)

<High Performance Mode: LPMODE bit = "0">

Table 3. Setting of Master Clock Frequency (High Performance Mode)

DSMLP bit	CM1 bit	CM0 bit	Master Clock Frequency	Sampling Frequency Range	
1	0	0	256fs	8 to 12 kHz	(default)
0	0	0	256fs	16 to 96 kHz	
			32fs	256 to 384 kHz	
0	0	1	512fs	8 to 48 kHz	
			64fs	256 to 384 kHz	
0	1	0	1024fs	8 to 24 kHz	
0	1	1	128fs	128 to 192 kHz	

<Low Power Mode: LPMODE bit = "1">

Table 4. Setting of Master Clock Frequency (Low Power Mode)

DSMLP bit	CM1 bit	CM0 bit	Master Clock Frequency	Sampling Frequency Range	
1	0	0	256fs	8 to 96 kHz	(default)
1	0	1	512fs	8 to 48 kHz	
1	1	0	1024fs	8 to 24 kHz	
1	1	1	128fs	128 to 192 kHz	

Note 67. The AK4376A does not support Oct speed mode (fs = 256 to 384 kHz) in low power mode.

Table 5. Setting of Sampling Frequency (N/A: Not available)

FS4 bit	FS3 bit	FS2 bit	FS1 bit	FS0 bit	Sampling Frequency	
0	0	0	0	0	8 kHz	(default)
0	0	0	0	1	11.025 kHz	
0	0	0	1	0	12 kHz	
0	0	1	0	0	16 kHz	
0	0	1	0	1	22.05 kHz	
0	0	1	1	0	24 kHz	
0	1	0	0	0	32 kHz	
0	1	0	0	1	44.1 kHz	
0	1	0	1	0	48 kHz	
0	1	1	0	0	64 kHz	
0	1	1	0	1	88.2 kHz	
0	1	1	1	0	96 kHz	
1	0	0	0	0	128 kHz	
1	0	0	0	1	176.4 kHz	
1	0	0	1	0	192 kHz	
1	0	1	0	0	256 kHz	
1	0	1	0	1	352.8 kHz	
1	0	1	1	0	384 kHz	
Others					N/A	

\* Depending on the PLL divider setting, the sampling frequency may differ. Please set PLD[15:0] and PLM[15:0] bits precisely.



■ PLL

The PLL generates a PLLCLK which is used as the DAC operation clock DACMCLK. The output frequency should be set in the range from 101.6064 to 122.88MHz (Table 6 shows setting example of 48 kHz and 44.1 kHz base rates). Refer to Table 11 to Table 12 for frequency setting examples. Reference clock of PLL should be set in the range from 256 kHz to 3.072 MHz.

Table 6. PLLCLK Setting Example

	48 kHz base rate	44.1 kHz base rate
2560/fs	122.88 MHz	112.896 MHz
2304/fs	110.592 MHz	101.6064 MHz

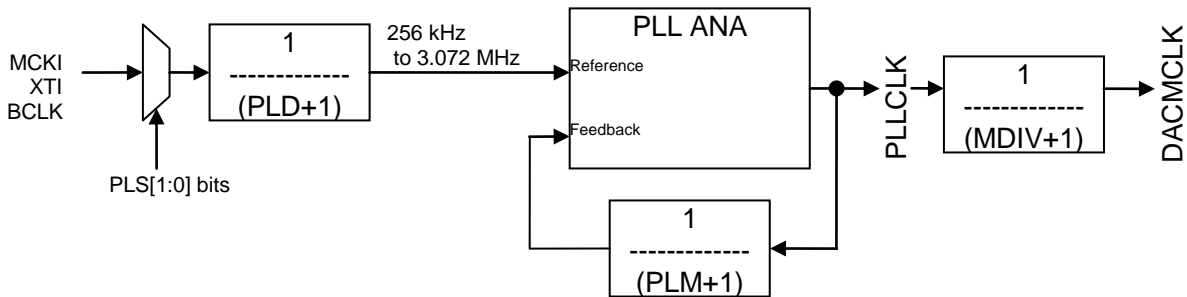

Reference clock = PLL Source / (PLD + 1)  
 PLLCLK = Reference clock x (PLM + 1)  
 DACMCLK = PLLCLK / (MDIV + 1)

Figure 11. PLL Block Diagram

■ Input Clock Select Function

The PLL has a function that selects the input clock. The clock source pin is selected by PLS[1:0] bits.

Table 7. PLL Clock Select (x: Do not care)

PLS[1:0] bits	Clock Source	
00	MCKI pin	(default)
01	BCLK pin	
1x	X'tal (XTI pin)	

1. PLL Reference Clock Divider

The PLL can set the dividing number of the reference clock in 16-bit. The input clock is used as PLL reference clock by dividing by (PLD+1).

Table 8. PLL Reference Clock Divider

PLD[15:0] bits	Dividing Number	
0000H	1	(default)
0001H to FFFFH	1 / (PLD + 1)	

Note 68. The reference clock divided by PLD should be set in the range from 256 kHz to 3.072 MHz.

## 2. PLL Feedback Clock Divider

The dividing number of feedback clock can be set freely in 16-bit. PLLCLK is divided by (PLM +1) and used as PLL feedback clock. The feedback clock is fixed to “L” without dividing when PLM[15:0] bits = 0000H.

Table 9. PLL Feedback Clock Divider

PLM[15:0] bits	Dividing Number	
0000H	Clock Stop	(default)
0001H to FFFFH	$1 / (PLM + 1)$	

## 3. Power Management (PMPLL)

PLL can be powered down by a control register setting.

Table 10. PLL Power Control

PMPLL bit	PLL Status	
0	Power-Down	(default)
1	Power-Up	

## 4. Frequency Setting Examples

Table 11. PLL Frequency Setting Example (PLL reference source: MCKI)

CLKIN		PLL condition			PLLCLK		
Source	Frequency [Hz]	D+1	REFCLK [Hz]	M+1	Base Rate [Hz]		
						[fs]	[Hz]
MCKI	9,600,000	5	1,920,000	64	48,000	2,560	122,880,000
	19,200,000	10	1,920,000	64		2,560	122,880,000
	12,288,000	4	3,072,000	40		2,560	122,880,000
	24,576,000	8	3,072,000	40		2,560	122,880,000
	12,000,000	25	480,000	256		2,560	122,880,000
	24,000,000	25	960,000	128		2,560	122,880,000
	9,600,000	25	384,000	294	44,100	2,560	112,896,000
	19,200,000	25	768,000	147		2,560	112,896,000
	11,289,600	4	2,822,400	40		2,560	112,896,000
	22,579,200	8	2,822,400	40		2,560	112,896,000

Table 12. PLL Frequency Setting Example (PLL reference source: BCLK)

CLKIN			PLL condition			PLLCLK		
Source	Sampling Frequency [Hz]	Frequency [Hz]	D+1	REFCLK [Hz]	M+1	Base Rate [Hz]		
							[fs]	[Hz]
BCLK (32fs)	8,000	256,000	1	256,000	480	48,000	2,560	122,880,000
	11,025	352,800	1	352,800	320	44,100	2,560	112,896,000
	16,000	512,000	1	512,000	240	48,000	2,560	122,880,000
	22,050	705,600	1	705,600	160	44,100	2,560	112,896,000
	24,000	768,000	1	768,000	160	48,000	2,560	122,880,000
	32,000	1,024,000	1	1,024,000	120	48,000	2,560	122,880,000
	44,100	1,411,200	1	1,411,200	80	44,100	2,560	112,896,000
	48,000	1,536,000	1	1,536,000	80	48,000	2,560	122,880,000
BCLK (48fs)	8,000	384,000	1	384,000	320	48,000	2,560	122,880,000
	11,025	529,200	1	529,200	192	44,100	2,304	101,606,400
	16,000	768,000	1	768,000	160	48,000	2,560	122,880,000
	22,050	1,058,400	3	352,800	320	44,100	2,560	112,896,000
	24,000	1,152,000	3	384,000	320	48,000	2,560	122,880,000
	32,000	1,536,000	1	1,536,000	80	48,000	2,560	122,880,000
	44,100	2,116,800	3	705,600	160	44,100	2,560	112,896,000
	48,000	2,304,000	3	768,000	160	48,000	2,560	122,880,000
BCLK (64fs)	8,000	512,000	1	512,000	240	48,000	2,560	122,880,000
	11,025	705,600	1	705,600	160	44,100	2,560	112,896,000
	16,000	1,024,000	1	1,024,000	120	48,000	2,560	122,880,000
	22,050	1,411,200	1	1,411,200	80	44,100	2,560	112,896,000
	24,000	1,536,000	1	1,536,000	80	48,000	2,560	122,880,000
	32,000	2,048,000	1	2,048,000	60	48,000	2,560	122,880,000
	44,100	2,822,400	1	2,822,400	40	44,100	2,560	112,896,000
	48,000	3,072,000	1	3,072,000	40	48,000	2,560	122,880,000

■ DACMCLK Generating Divider Setting

MDIV[7:0] bits control DACMCLK divider.

Table 13. DACMCLK Divider Setting

MDIV[7:0] bits	Dividing Number
00H	1
01H to FFH	1 / (MDIV + 1)

(default)

■ Crystal Oscillator

The clock for the XTI pin can be generated by two methods. PMOSC bit must be set to “1” when using a crystal oscillator.

1) X’tal Mode (PMOSC bit = “1”)

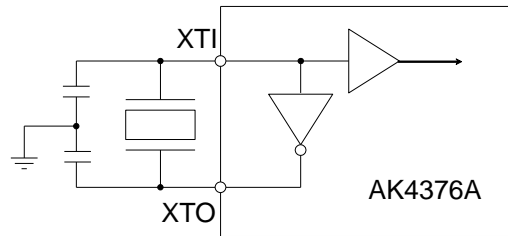

Figure 12. X’tal Mode

Note 69. The capacitor value is dependent on the crystal oscillator.

$C_L = 21.5 \text{ pF (Max.)}$ ,  $R_l \text{ (Equivalent Series Resistance)} = 80\Omega \text{ (Max.) @ } 24.576 \text{ MHz}$

$C_L = 30.6 \text{ pF (Max.)}$ ,  $R_l \text{ (Equivalent Series Resistance)} = 200\Omega \text{ (Max.) @ } 11.2896 \text{ MHz}$

2) External Clock Mode (PMOSC bit = “0”)

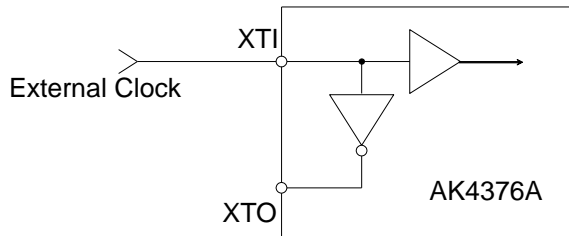

Figure 13. External Clock Mode

Note 70. Do not input a clock more than AVDD.

3) OFF Mode (Not Using XTI/XTO pins (PMOSC bit = “0”))

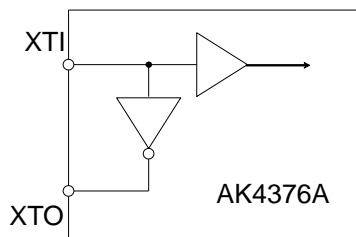

Figure 14. OFF Mode

### ■ DAC Digital Filter

The AK4376A has four types of digital filter. The filter mode of DAC can be selected by DASD and DASL bits. The default setting is DASL bit = DASD bit = "0" (Sharp Roll-Off Filter).

Table 14. DAC Digital Filter Setting

DASD bit	DASL bit	DAC Filter Mode Setting	(default)
0	0	Sharp Roll-Off Filter	
0	1	Slow Roll-Off Filter	
1	0	Short Delay Sharp Roll-Off Filter	
1	1	Short Delay Slow Roll-Off Filter	

### ■ Digital Mixing

The AK4376A has digital mixing circuits for each Lch and Rch. They can mix the data digitally and convert the polarity. The inverted data by this polarity conversion is calculated in 2's complement format.

Table 15. DAC L/Rch Input Signal Select

MDACL bit MDACR bit	RDACL bit RDACR bit	LDACL bit LDACR bit	DAC Lch Input Data DAC Rch Input Data	(default)
0	0	0	MUTE	
0	0	1	Lch	
0	1	0	Rch	
0	1	1	Lch + Rch	
1	0	0	MUTE	
1	0	1	Lch/2	
1	1	0	Rch/2	
1	1	1	(Lch + Rch)/2	

Table 16. DAC L/Rch Input Signal Polarity Select

INVL bit INVR bit	Output Data	(default)
0	Normal	
1	Inverting	

## ■ Digital Volume

The AK4376A has a 32-level digital volume in front of DAC for each L and R channel. The volume is changed from +3 dB to -12 dB in 0.5 dB step including Mute. The volume change is executed immediately by setting registers.

When OVOLCN bit is "1", the OVL[4:0] bits control Lch level and OVR[4:0] bits control Rch level. When OVOLCN bit = "0", the OVL[4:0] bits control both Lch and Rch attenuation levels. In this case, the setting of OVR[4:0] bits is ignored.

When Oct Speed Mode ( $f_s = 256$  to  $384$  kHz), Digital Volume cannot be used.

Table 17. Digital Volume Setting

OVL[4:0] bits OVR[4:0] bits	Volume (dB)
1FH	+3
1EH	+2.5
1DH	+2
1CH	+1.5
1BH	+1
1AH	+0.5
19H	0 (default)
18H	-0.5
17H	-1
16H	-1.5
15H	-2
14H	-2.5
13H	-3
12H	-3.5
11H	-4
10H	-4.5
0FH	-5
0EH	-5.5
0DH	-6
0CH	-6.5
0BH	-7
0AH	-7.5
09H	-8
08H	-8.5
07H	-9
06H	-9.5
05H	-10
04H	-10.5
03H	-11
02H	-11.5
01H	-12
00H	MUTE

■ Headphone Amplifier Output (HPL/HPR pins)

Headphone amplifiers are operated by positive and negative power that is supplied from internal charge pump circuit. The VEE2 pin output the negative voltage generated by the internal charge pump circuit from CVDD. This charge pump circuit is switched between VDD mode and 1/2VDD mode by the output level of the headphone amplifiers. The headphone amplifier output is single-ended and centered on HPGND (0 V). A capacitor for AC coupling is not necessary. The load resistance is 14.4Ω (Min.). The output power is 10 mW when 0 dBFS,  $R_L = 32\Omega$ ,  $AVDD = CVDD = 1.8\text{ V}$  and  $HPG = -4\text{ dB}$ , and it is 25 mW when 0 dBFS,  $R_L = 32\Omega$ ,  $AVDD = 1.8\text{ V}$  and  $HPG = 0\text{ dB}$ . Ground loop noise cancelling function for headphone amplifier is available by connecting the HPGND pin to the ground of the jack.

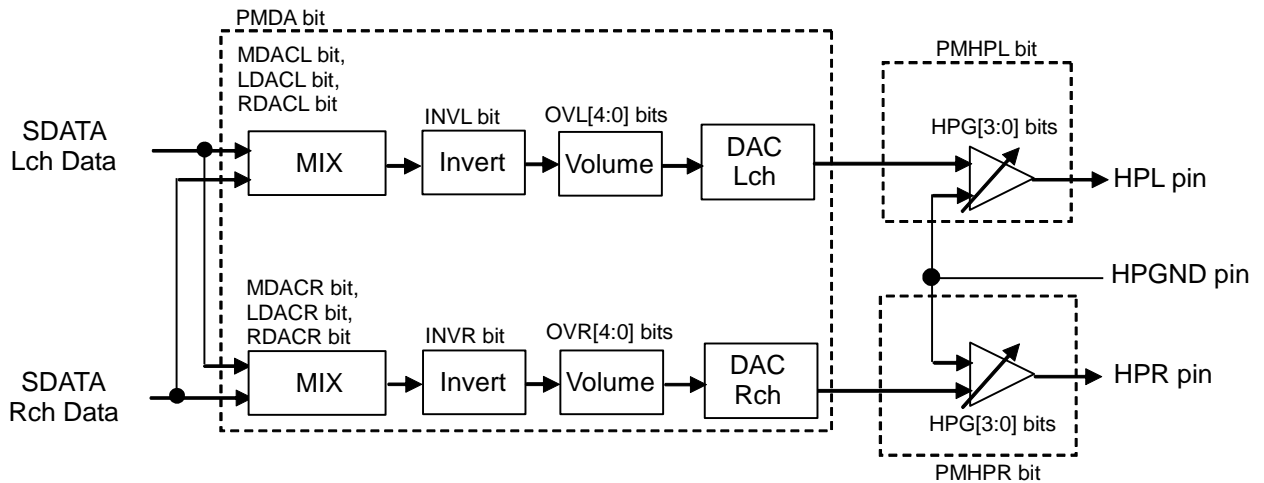

Figure 15. DAC & Headphone-Amp Block Diagram

Table 18. Charge Pump Mode Setting (N/A: Not available)

CPMODE1 bit	CPMODE0 bit	Mode	Operation Voltage
0	0	Class-G Operation Mode	Automatic Switching (default)
0	1	$\pm VDD$ Operation Mode	$\pm VDD$
1	0	$\pm 1/2 VDD$ Operation Mode	$\pm 1/2 VDD$
1	1	N/A	N/A

• Class-G Mode Switching Level:

$VDD \rightarrow 1/2 VDD$ :  $< 1.05\text{ mW}$  at both channels (@  $CVDD = 1.8\text{ V}$ ,  $R_L = 32\Omega$ )

$1/2 VDD \rightarrow VDD$ :  $\geq 1.05\text{ mW}$  at either channel (@  $CVDD = 1.8\text{ V}$ ,  $R_L = 32\Omega$ )

When the charge pump operation mode is changed to VDD mode from 1/2 VDD mode, an internal counter for holding VDD mode starts (Table 19). The charge pump changes to 1/2 VDD mode if the output signal level is lower than the switching level and 1/2 VDD mode detection time that is set by LVDTM[2:0] bits is passed after VDD mode hold time is finished.

Table 19. VDD Mode Holding Period Setting (x: Do not care)

VDDTM[3:0] bits	VDD Mode Holding Period					
		8 kHz	44.1 kHz	96 kHz	192 kHz	
0000	1024/fs	128 ms	23.2 ms	10.7 ms	5.3 ms	(default)
0001	2048/fs	256 ms	46.4 ms	21.3 ms	10.7 ms	
0010	4096/fs	512 ms	92.9 ms	42.7 ms	21.3 ms	
0011	8192/fs	1024 ms	186 ms	85.3 ms	42.7 ms	
0100	16384/fs	2048 ms	372 ms	170.7 ms	85.3 ms	
0101	32768/fs	4096 ms	743 ms	341.3 ms	170.7 ms	
0110	65536/fs	8192 ms	1486 ms	682.7 ms	341.3 ms	
0111	131072/fs	16384 ms	2972 ms	1365.3 ms	682.7 ms	
1xxx	262144/fs	32768 ms	5944 ms	2730.7 ms	1365.3 ms	

Note 71. Oct speed mode (fs = 256 k / 352.8 k / 384 kHz) has the same cycle as fs = 32 k / 44.1 k / 48 kHz.

When the output voltage becomes less than class-G mode switching level, the internal detection counter for 1/2 VDD mode which is set by LVDTM[2:0] bits starts. This counter is reset when the output voltage exceeds class-G mode switching level. The charge pump operation mode is changed to VDD from 1/2 VDD if the detection counter of 1/2VDD mode is finished and also the VDD mode hold period is passed.

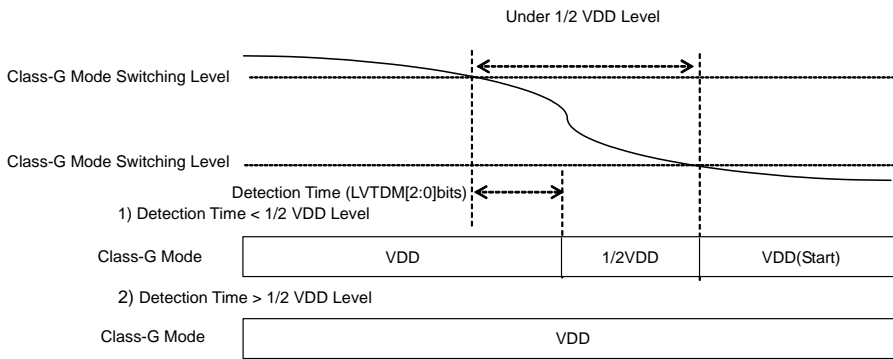

Figure 16. Transition to 1/2 VDD Mode from VDD Mode



Table 20. 1/2VDD Detection Period (Minimum frequency that is not detected)

LVDTM[2:0] bits		1/2 VDD Mode Detection Time / Minimum Frequency That Is Not Detected				
		8 kHz	44.1 kHz	96 kHz	192 kHz	
000	64/fs	8 ms	1.5 ms	0.67 ms	0.33 ms	(default)
		62.5 Hz	344.5 Hz	750 Hz	1500 Hz	
001	128/fs	16 ms	2.9 ms	1.3 ms	0.67 ms	
		31.3 Hz	172.3 Hz	375 Hz	750 Hz	
010	256/fs	32 ms	5.8 ms	2.7 ms	1.3 ms	
		15.6 Hz	86.1 Hz	187.5 Hz	375 Hz	
011	512/fs	64 ms	11.6 ms	5.3 ms	2.7 ms	
		7.8 Hz	43.1 Hz	93.8 Hz	187.5 Hz	
100	1024/fs	128 ms	23.2 ms	10.7 ms	5.3 ms	
		3.9 Hz	21.5 Hz	46.9 Hz	93.8 Hz	
101	2048/fs	256 ms	46.4 ms	21.3 ms	10.7 ms	
		2.0 Hz	10.8 Hz	23.4 Hz	46.9 Hz	
110	4096/fs	512 ms	92.9 ms	42.7 ms	21.3 ms	
		1.0 Hz	5.4 Hz	11.7 Hz	23.4 Hz	
111	8192/fs	1024 ms	185.8 ms	92.9 ms	42.7 ms	
		0.5 Hz	2.7 Hz	5.9 Hz	11.7 Hz	

Note 72. Oct speed mode (fs = 256 k / 352.8 k / 384 kHz) has the same cycle as fs = 32 k / 44.1 k / 48 kHz.

The output level of the headphone amplifier is controlled by HPG[3:0] bits. The volume setting is common for both L and R channels and ranges from +6dB to -20 dB in 2 dB step (Table 21). The volume change is executed immediately by setting registers.

Table 21. Headphone Amplifier Volume Setting (N/A: Not available)

HPG[3:0] bits	Volume (dB)	
FH	N/A	(default)
EH	+6	
DH	+4	
CH	+2	
BH	0	
AH	-2	
9H	-4	
8H	-6	
7H	-8	
6H	-10	
5H	-12	
4H	-14	
3H	-16	
2H	-18	
1H	-20	
0H	MUTE	

### < Headphone Amplifier External Circuit >

It is necessary to put an oscillation prevention circuit (0.1  $\mu\text{F}$   $\pm 20\%$  capacitor and 10 $\Omega$   $\pm 20\%$  resistor) because there is a possibility that the headphone amplifier oscillates.

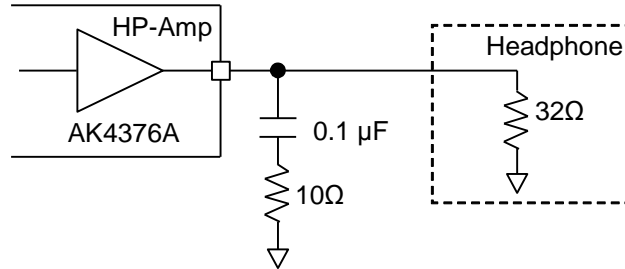

Figure 17. Headphone Amplifier Oscillation Prevention Circuit Example

### < Power-Up/Down Sequence of Headphone Amplifier >

After releasing DAC power-down state by PMDA bit, the headphone amplifier should be powered up by PMHPL/R bits. A wait time from DAC power-up to headphone power-up is not necessary. PMDA bit releases a power-down of the digital block of the DAC, PMHPL bit or PMHPR bit powers up the analog block of the DAC and the headphone amplifier. Then, initialization cycle of the headphone amplifier is executed. The gain setting (HPG[3:0] bits) should be made before PMHPL bit or PMHPR bit is set to "1". Do not change the gain setting (HPG[3:0] bits) during the headphone initialization cycle. The gain setting can be changed after the headphone initialization cycle is finished. A wait time from the gain setting to PMHPL bit or PMHPR bit = "1" is not necessary.

When the AK4376A is powered down, the headphone amplifier should be powered down first. The DAC should be powered down next. A wait time from a headphone power-down to the DAC power-down is not necessary.

When the headphone amplifier is powered down, the HPL pin and the HPR pin are pulled down to HPGND via the internal pull-down register. The pull-down resistor is 6 $\Omega$  (Typ.) @ HPLHZ bit = HPRHZ bit = "0". When the headphone amplifier is powered down, the HPL pin and the HPR pin are pulled down by 200 k $\Omega$  (Typ.) by setting HPLHZ bit and HPRHZ bit to "1", respectively. These bits must be set to "0" before power up the headphone amplifier.

Table 22. Headphone Lch Output Status (N/A: Not available)

PMHPL bit	HPLHZ bit	HP-Amp Status
0	0	Pull-Down by 6 $\Omega$ (Typ.)
0	1	Pull-Down by 200 k $\Omega$ (Typ.)
1	0	Normal Operation
1	1	N/A

Table 23. Headphone Rch Output Status (N/A: Not available)

PMHPR bit	HPRHZ bit	HP-Amp Status
0	0	Pull-Down by 6 $\Omega$ (Typ.)
0	1	Pull-Down by 200 k $\Omega$ (Typ.)
1	0	Normal Operation
1	1	N/A

When the HPL pin and the HPR pin are connected to analog signal pins of an external device by Wire-OR, CP1, CP2, LDO1P and LDO1N should be powered up. Do not input a negative voltage to the HPL and the HPR pins when CP1, CP2, LDO1P and LDO1N are powered down.

If the pop noise at power-down exceeds an acceptable range, headphone amplifier should be powered down after attenuating the headphone volume gradually until mute.

The power-up time of headphone amplifier is shown in Table 24. The HPL pin and the HPR pin output 0 V (HPGND) when the headphone amplifier is powered up. The power-down is executed immediately.

Table 24. Headphone Power Up Time

Sampling Frequency [kHz]	Power-Up Time (Max.)
8/12/16/24/32/48/64/96/128/192/256/384	23.9 ms
11.025/22.05/44.1/88.2/176.4/352.8	25.9 ms

<Power-Up Sequence Example>

1. DAC Initial Settings (Write "20H" data into DAC Adjustment1 (Addr.26H),  
Write "05H" data into DAC Adjustment2 (Addr.2AH)) (Note 73)
2. Audio I/F, DAC Clock, Sampling Frequency, Path, Digital Volume, Analog Volume Settings
3. CP1 Power-Up (PMCP1 bit: "0" → "1")
4. Wait 6.5 ms (Note 74)
5. LDO1P & LDO1N Power-Up (PMLDO1P bit & PMLDO1N bit: "0" → "1")
6. Wait 1 ms (Note 74)
7. DAC Power-Up (PMDA bit: "0" → "1")
8. CP2 Power-Up (PMCP2 bit: "0" → "1")
9. Wait 4.5 ms (Note 74)
10. Headphone Amplifier Power-Up (PMHPL bit & PMHPR bit: "0" → "1")
11. Wait 25.9 ms (@ fs = 44.1 kHz)
12. Playback

<Power-Down Sequence Example>

1. Headphone Amplifier Power-Down (PMHPL bit & PMHPR bit: "1" → "0")
2. CP2 Power-Down (PMCP2 bit: "1" → "0")
3. DAC Power-Down (PMDA bit: "1" → "0")
4. LDO1P & LDO1N Power-Down (PMLDO1P bit & PMLDO1N bit: "1" → "0")
5. CP1 Power-Down (PMCP1 bit: "1" → "0")
6. Stop

Note 73. Recommended setting of DAC Adjustment2 (Addr.2AH) is "05H" data. However, T[15:12] bits setting should be changed appropriately since the optimum setting for T[15:12] bits varies depending on the PCB layout.

Note 74. Refer to "■ Charge Pump & LDO Circuit Power-up Time"

**< Low Power Mode >**

The DAC and the headphone amplifier will be in low power mode by setting LPMODE bit and DSMLP bit to "1". PMHPL bit and PMHPR bit must be set to "0" when changing operation mode of the DAC and the headphone amplifier between low power mode and high performance mode. The AK4376A does not support Oct speed mode ( $f_s = 256$  to  $384$  kHz) in low power mode.

Table 25. DAC, HP-Amp Mode Setting

LPMODE bit	Mode
0	High Performance Mode (default)
1	Low Power Mode

## &lt; Noise Gate &gt;

When NGDIS bit = "0", a noise gate is enabled and noise level will be improved if both L and R channels input data of the DAC is continuously "0" for the period set by NGT and FS[4:0] bits. The noise gate will be disabled if one of these L channel and R channel input data of the DAC is not "0" even once and the AK4376A returns to normal operation from the state that Noise gate is enabled. The noise gate is always disable when NGDIS bit = "1" or when LPMODE bit = "1" (in low power mode). It is only available in high performance mode (LPMODE bit = "0"). PMDA bit, PMHPL bit and PMHPR bit must be set to "0" when changing NGT bit.

Table 26. Noise Gate Zero Detection Period (N/A: Not available)

NGT bit	FS4 bit	FS3 bit	FS2 bit	FS1 bit	FS0 bit	Sampling Frequency (fs)	Zero Detection Time	
0	0	0	0	0	0	8 kHz	128.0 ms	1024/fs
	0	0	0	0	1	11.025 kHz	92.9 ms	1024/fs
	0	0	0	1	0	12 kHz	85.3 ms	1024/fs
	0	0	1	0	0	16 kHz	128.0 ms	2048/fs
	0	0	1	0	1	22.05 kHz	92.9 ms	2048/fs
	0	0	1	1	0	24 kHz	85.3 ms	2048/fs
	0	1	0	0	0	32 kHz	128.0 ms	4096/fs
	0	1	0	0	1	44.1 kHz	92.9 ms	4096/fs
	0	1	0	1	0	48 kHz	85.3 ms	4096/fs
	0	1	1	0	0	64 kHz	128.0 ms	8192/fs
	0	1	1	0	1	88.2 kHz	92.9 ms	8192/fs
	0	1	1	1	0	96 kHz	85.3 ms	8192/fs
	1	0	0	0	0	128 kHz	128.0 ms	16384/fs
	1	0	0	0	1	176.4 kHz	92.9 ms	16384/fs
	1	0	0	1	0	192 kHz	85.3 ms	16384/fs
	1	0	1	0	0	256 kHz	128.0 ms	32768/fs
	1	0	1	0	1	352.8 kHz	92.9 ms	32768/fs
	1	0	1	1	0	384 kHz	85.3 ms	32768/fs
Others						N/A	-	N/A
1	0	0	0	0	0	8 kHz	256.0 ms	2048/fs
	0	0	0	0	1	11.025 kHz	185.8 ms	2048/fs
	0	0	0	1	0	12 kHz	170.7 ms	2048/fs
	0	0	1	0	0	16 kHz	256.0 ms	4096/fs
	0	0	1	0	1	22.05 kHz	185.8 ms	4096/fs
	0	0	1	1	0	24 kHz	170.7 ms	4096/fs
	0	1	0	0	0	32 kHz	256.0 ms	8192/fs
	0	1	0	0	1	44.1 kHz	185.8 ms	8192/fs
	0	1	0	1	0	48 kHz	170.7 ms	8192/fs
	0	1	1	0	0	64 kHz	256.0 ms	16384/fs
	0	1	1	0	1	88.2 kHz	185.8 ms	16384/fs
	0	1	1	1	0	96 kHz	170.7 ms	16384/fs
	1	0	0	0	0	128 kHz	256.0 ms	32768/fs
	1	0	0	0	1	176.4 kHz	185.8 ms	32768/fs
	1	0	0	1	0	192 kHz	170.7 ms	32768/fs
	1	0	1	0	0	256 kHz	256.0 ms	65536/fs
	1	0	1	0	1	352.8 kHz	185.8 ms	65536/fs
	1	0	1	1	0	384 kHz	170.7 ms	65536/fs
Others						N/A	-	N/A

Table 27. Noise Gate Setting

NGDIS bit	Noise Gate Status
0	Enable (default)
1	Disable

**< Overcurrent Protection Circuit >**

If the headphone amplifier is in an overcurrent state, such as when output pins are shorted, the headphone amplifier limits the operation current. The headphone amplifier returns to a normal operation state if all causes are cleared.

## ■ Charge Pump & LDO Circuits

The charge pump circuits are operated by CVDD power supply voltage. CVDD is used to generate negative voltage. The power-up/down sequence of charge pump and LDO circuits are as follows. CP1 should be powered up before LDO1P/N are powered up. CP2 should be powered up after LDO1P/N are powered up. LDO1P and LDO1N blocks must be powered up or down at the same time.

**Power-Up Sequence: CP1 → LDO1P, LDO1N → CP2**

**Power-Down Sequence: CP2 → LDO1P, LDO1N → CP1**

LDO1P and LDO1N have an overcurrent protection circuit. When overcurrent flows in a normal operation, the LDO1P and LDO1N circuits limit the operation current. If the over current state is cleared, the overcurrent protection will be off and the LDO1P and LDO1N circuits will return to normal operation.

LDO2 has an overvoltage protection circuit. This overvoltage protection circuit powers the LDO2 down when the power supply becomes unstable by an instantaneous power failure, etc. during operation. The LDO2 circuit will not return to a normal operation until being reset by the PDN pin ("L" → "H") after removing the problems.

The charge pump and the LDO circuits can be powered up again while they are in power-down state.

Table 28. Input/Output Voltage and Operation Block of the Charge Pump

Charge Pump	Power Management bit	Input Voltage	Output Voltage (Typ.)	Operation Block
CP1	PMCP1	CVDD	-1.8 V	LDO1N DAC
CP2 (Class-G)	PMCP2	CVDD	±1.8 V / ±0.9 V	HP

Table 29. Input/Output Voltage and Operation Block of the LDO

LDO	Power Management bit	Power Supply	Output Voltage (Typ.)	Operation Block
LDO1P	PMLDO1P	AVDD / VSS1	+1.5 V	VREF+ for DAC, HP
LDO1N	PMLDO1N	VSS1 / CP2 Output	-1.5 V	VREF- for DAC, HP
LDO2	-	LVDD / VSS1	+1.2 V	Digital Core

■ Serial Audio Interface

The serial audio interface format is set by DIF bit and its data length is controlled by DL[1:0] bits. In case that the input data length is less than the value which set by DL[1:0] bits, unused lower bits are filled with "0". When using master mode, DL[1:0] bits is set in accordance with the setting of BCKO bit.

Table 30. Digital I/F Format Setting

DIF bit	Digital I/F Format
0	I <sup>2</sup> S Compatible (default)
1	MSB justified

Table 31. Data Length Setting (x: Do not care)

DL1 bit	DL0 bit	Data Length	BCLK Frequency	
			Slave Mode	Master Mode
0	0	24-bit linear	≥ 48fs	64fs (BCKO bit = "0") (default)
0	1	16-bit linear	≥ 32fs	32fs (BCKO bit = "1")
1	x	32-bit linear	≥ 64fs	64fs (BCKO bit = "0")

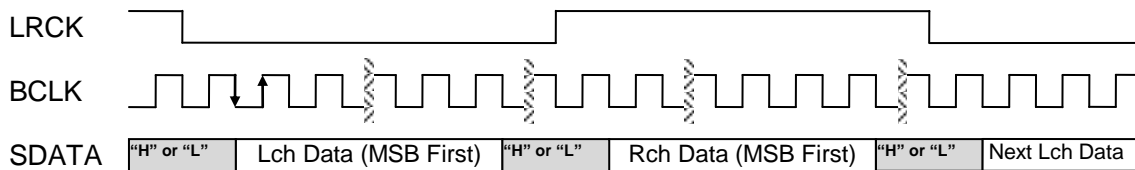

Figure 18. I<sup>2</sup>S Compatible Format (DIF bit = "0")

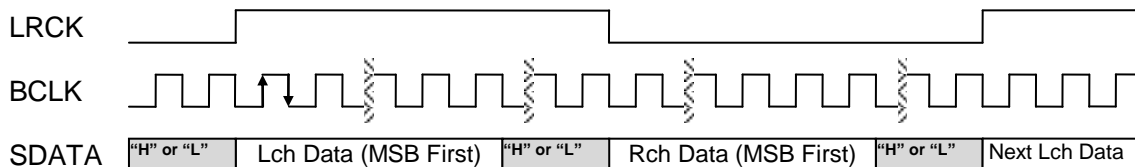

Figure 19. MSB justified format (DIF bit= "1")



## ■ Power-up & Operation Mode

### Power Down State (PDN pin = "L")

When the PDN pin is "L", the AK4376A is in a power-down state. Power supplies must be applied when the PDN pin = "L". Set the PDN pin to "H" to release the power-down state after all the power supplies are on. More than one tPDN cycle of "L" period is needed before releasing the power-down state. The state of the AK4376A transitions to LDO2 Ctrl state by bringing the PDN pin to "H".

### LDO2 Ctrl State

This is a state to control the LDO2.

LDO2 is powered up and the internal DRSTN signal is changed from "L" to "H" after max. 1 ms, and the AK4376A enters a Standby state.

### Standby State

I<sup>2</sup>C interface is powered up and register accesses are enabled.

\*10ms (min.) wait time for power-up of analog circuit blocks (CP1, CP2, LDO1P, LDO1N, DAC, HP-Amp and PLL) is needed after setting the PDN pin to "H" to release the power-down state.

<State Transition Diagram>

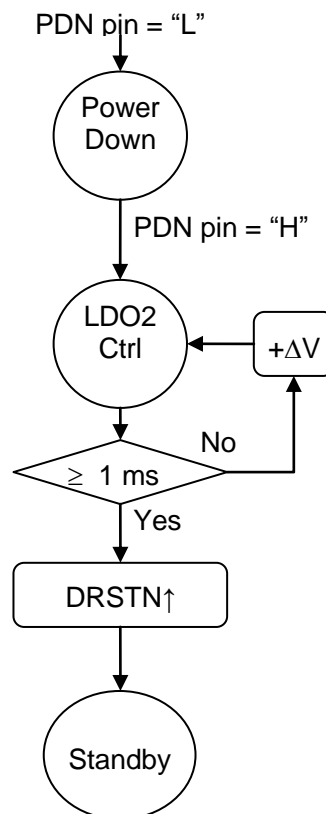

Figure 20. Device State Diagram

1. PDN pin "L" → "H"
2. Wait 1 ms until LDO2 1.2V output is stable.
3. Internal DRSTN Signal: "L" → "H"
4. Register Access Ready

## ■ Serial Control Interface (I<sup>2</sup>C-bus)

The AK4376A supports the fast-mode I<sup>2</sup>C-bus (max: 400 kHz). Pull-up resistors at the SDA and SCL pins must be connected to (TVDD +0.3) V or less voltage.

### 1. WRITE Operation

Figure 21 shows the data transfer sequence for the I<sup>2</sup>C-bus mode. All commands are preceded by a START condition. A HIGH to LOW transition on the SDA line while SCL is HIGH indicates a START condition (Figure 27). After the START condition, a slave address is sent. This address is 7 bits long followed by the eighth bit that is a data direction bit (R/W). The most significant seven bits of the slave address are fixed as “0010000”. If the slave address matches that of the AK4376A, the AK4376A generates an acknowledge and the operation is executed. The master must generate the acknowledge-related clock pulse and release the SDA line (HIGH) during the acknowledge clock pulse (Figure 28). A R/W bit value of “1” indicates that the read operation is to be executed, and “0” indicates that the write operation is to be executed.

The second byte consists of the control register address of the AK4376A. The format is MSB first 8 bits (Figure 23). The data after the second byte contains control data. The format is MSB first, 8 bits (Figure 24). The AK4376A generates an acknowledge after each byte is received. Data transfer is always terminated by a STOP condition generated by the master. A LOW to HIGH transition on the SDA line while SCL is HIGH defines a STOP condition (Figure 27).

The AK4376A can perform more than one byte write operation per sequence. After receipt of the third byte the AK4376A generates an acknowledge and awaits the next data. The master can transmit more than one byte instead of terminating the write cycle after the first data byte is transferred. After receiving each data packet the internal address counter is incremented by one, and the next data is automatically taken into the next address. If the address exceeds “15H” prior to generating a stop condition, the address counter will “roll over” to “00H” and the previous data will be overwritten.

The data on the SDA line must remain stable during the HIGH period of the clock. HIGH or LOW state of the data line can only be changed when the clock signal on the SCL line is LOW (Figure 29) except for the START and STOP conditions.

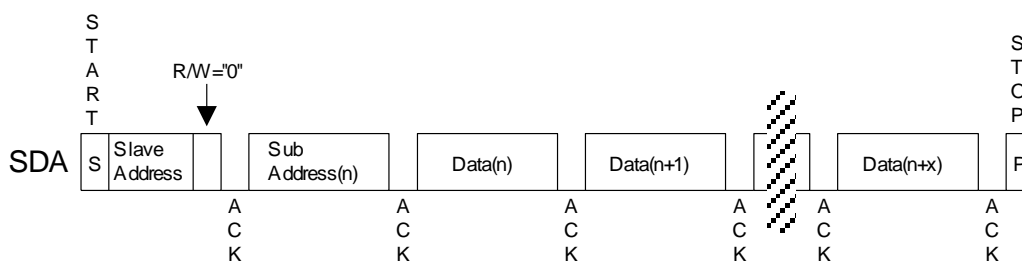

Figure 21. Data Transfer Sequence in I<sup>2</sup>C Bus Mode

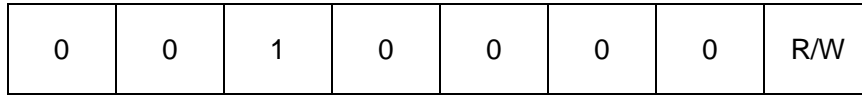

Figure 22. The First Byte

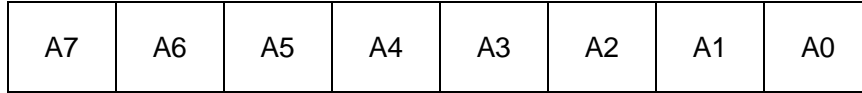

Figure 23. The Second Byte

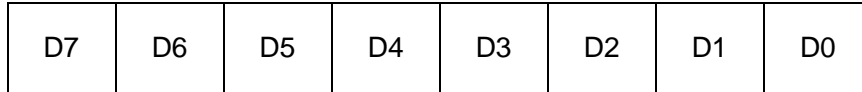

Figure 24. The Third Byte

## 2. READ Operation

Set the R/W bit = "1" for the READ operation of the AK4376A. After transmission of data, the master can read the next address's data by generating an acknowledge instead of terminating the write cycle after the receipt of the first data word. After receiving each data packet the internal address counter is incremented by one, and the next data is automatically taken into the next address. If the address exceeds "15H" prior to generating stop condition, the address counter will "roll over" to "00H" and the data of "00H" will be read out.

The AK4376A supports two basic read operations: Current Address READ and Random Address READ.

### 2-1. Current Address READ

The AK4376A has an internal address counter that maintains the address of the last accessed word incremented by one. Therefore, if the last access (either a read or write) were to address "n", the next Current READ operation would access data from the address "n+1". After receipt of the slave address with R/W bit "1", the AK4376A generates an acknowledge, transmits 1-byte of data to the address set by the internal address counter and increments the internal address counter by 1. If the master does not generate an acknowledge but generates a stop condition instead, the AK4376A ceases the transmission.

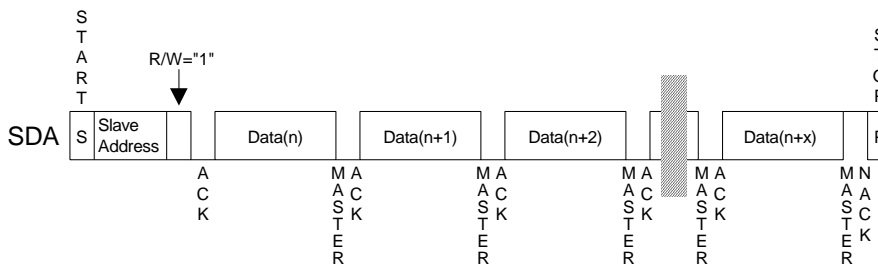

Figure 25. Current Address READ

2-2. Random Address READ

The random read operation allows the master to access any memory location at random. Prior to issuing the slave address with the R/W bit "1", the master must first perform a "dummy" write operation. The master issues a start request, a slave address (R/W bit = "0") and then the register address to read. After the register address is acknowledged, the master immediately reissues the start request and the slave address with the R/W bit "1". The AK4376A then generates an acknowledge, 1 byte of data and increments the internal address counter by 1. If the master does not generate an acknowledge but generates a stop condition instead, the AK4376A ceases the transmission.

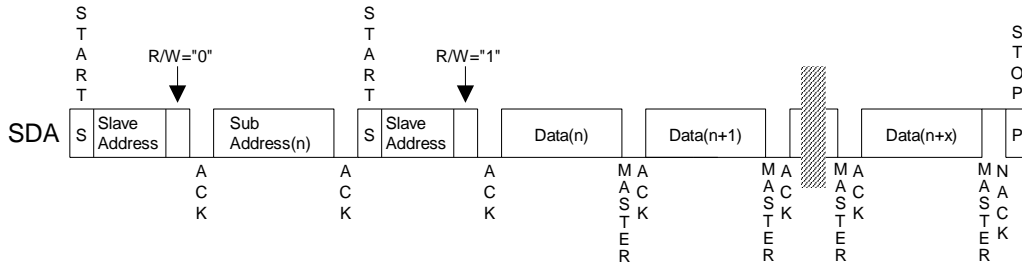

Figure 26. Random Address READ

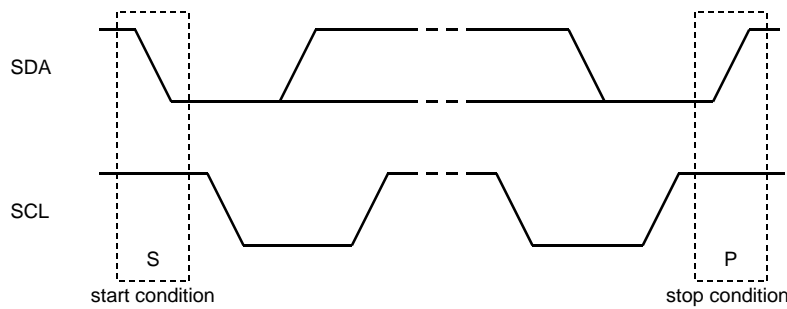

Figure 27. Start Condition and Stop Condition

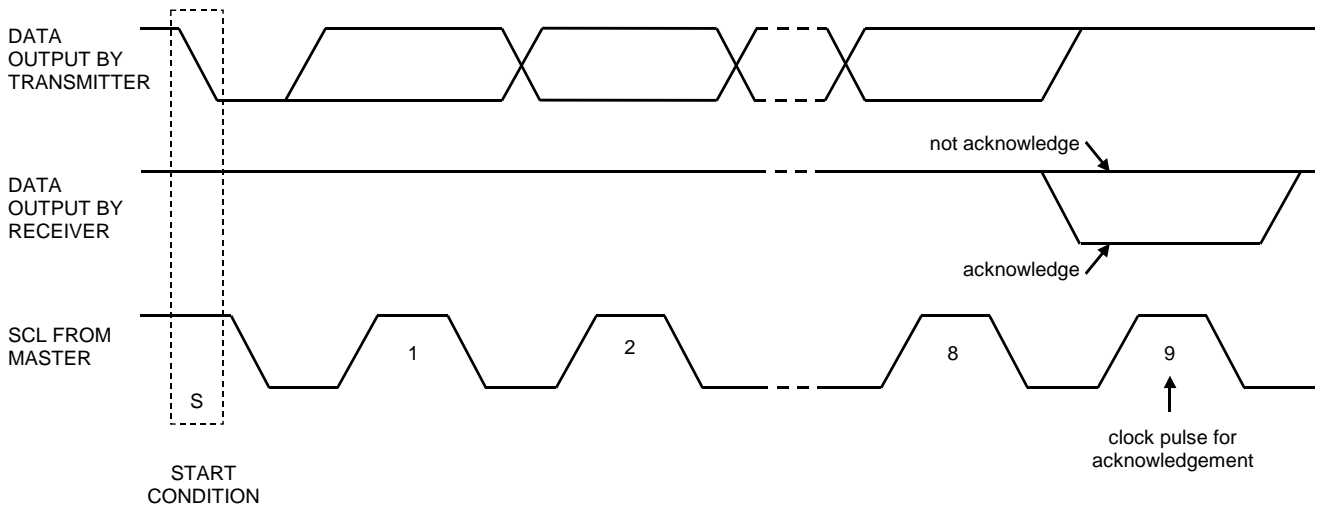

Figure 28. Acknowledge (I<sup>2</sup>C Bus)

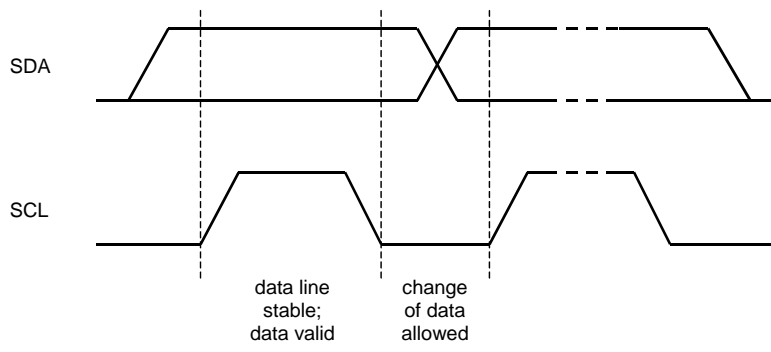

Figure 29. Bit Transfer (I<sup>2</sup>C Bus)

■ Control Sequence

Figure 30 shows power up sequence of the headphone amplifier.

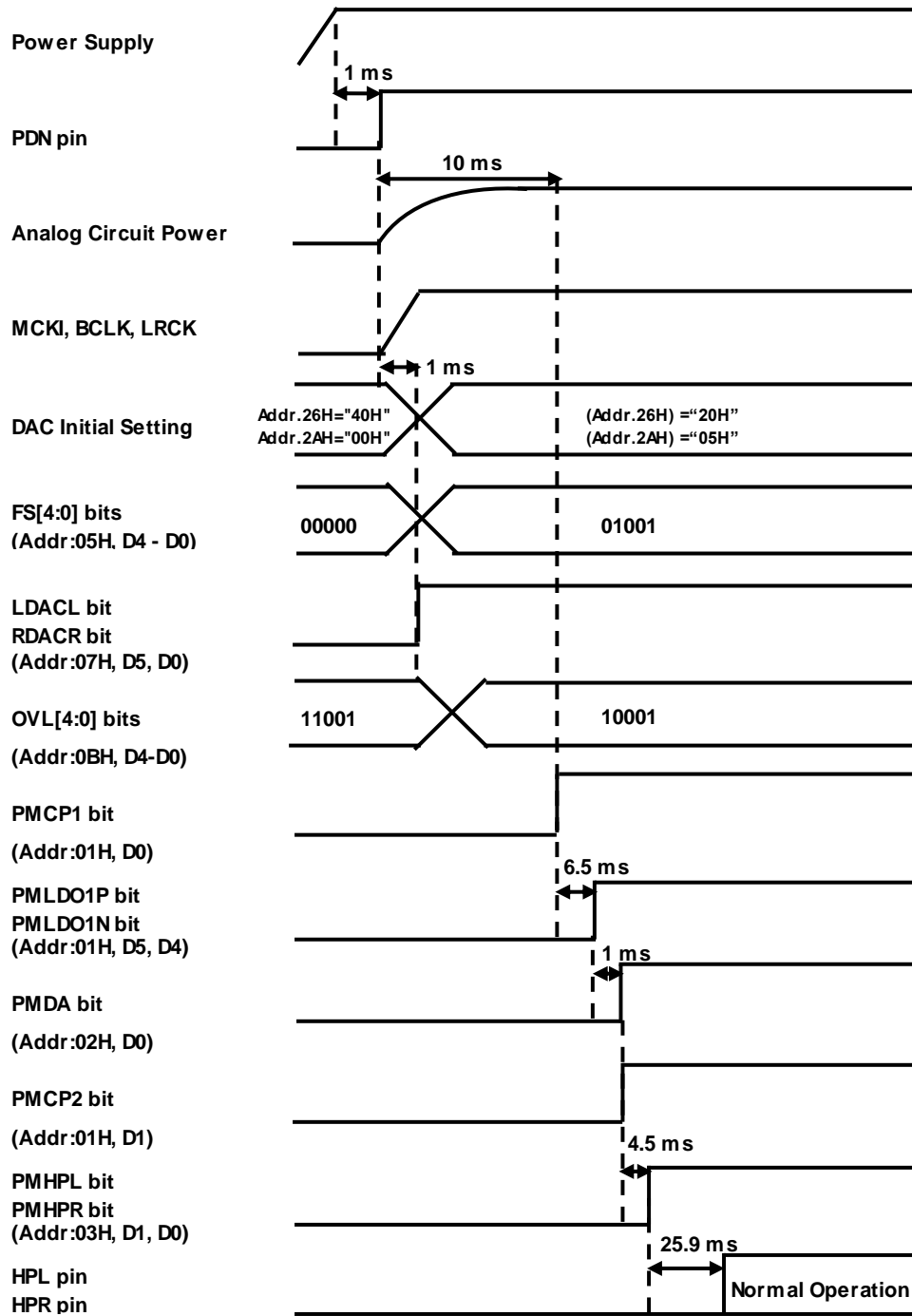

Figure 30. Power Up Sequence Example of Headphone Amplifier

## &lt;Sequence&gt;

- (1) Set the PDN pin “L” → “H” after the AK4376A is powered up. In this case, 1ms or more “L” time is needed for a certain reset. (MCKI, BCLK, LRCK, SDATA, SCL and SDA should be input after all power supplies are ON.)
- (2) Set the PDN pin = “H” to release the power down. Register access will be valid after 0.8 ms. However, a wait time of 10 ms is needed to access power management bits of the analog circuit (PMCP1 bit, PMCP2 bit, PMLDO1P bit, PMLDO1N bit, PMDAC bit, PMHPL bit, PMHPR bit, PMPLL bit) until the analog circuit is powered up. Execute register write after analog circuit is powered up.
- (3) Input MCKI, BCLK and LRCK.
- (4) Set sampling frequency (FS[4:0] bits) and the input signal path of the DAC (LDACL bit = RDACR bit = “0” → “1”).
- (5) Set DAC digital volume by OVL[4:0] bits.  
Both Lch and Rch volumes are controlled by OVL[4:0] bits when OVOLCN bit = “1” (default).
- (6) Power up CP1 (PMCP1 bit= “0” → “1”)   
LDO1P and LDO1N should be powered up (PMLDO1P bit = PMLDO1N bit = “0”→“1”) after 6.5 ms (Note 75) from CP1 power-up.
- (7) Power up DAC (PMDA bit = “0” → “1”)   
DAC must be powered up after 1 ms (Note 75) from LDO1P and LDO2P power up.
- (8) Power up CP2 (PMCP2 bit = “0” → “1”)   
CP2 must be powered up after LDO1P and LDO1N are powered up.
- (9) Power up HPL and HPR (PMHPL bit = PMHPR bit = “0” → “1”)   
HPL and HPR should be powered up after 4.5 ms (Note 75) from CP2 power up.   
The power-up time of HP-Amp is 25.9 ms (@ fs = 44.1 kHz). The HPL pin and the HPR pin output 0 V until the HP-Amp is powered up.

Note 75. Refer to “■ Charge Pump & LDO Circuit Power-up Time”

## ■ Register Map

Addr	Register Name	D7	D6	D5	D4	D3	D2	D1	D0	
00H	Power Management 1	0	0	0	PMOSC	0	0	0	PMPLL	
01H	Power Management 2	0	0	PMLDO1N	PMLDO1P	0	0	PMCP2	PMCP1	
02H	Power Management 3	0	0	0	LPMODE	0	0	0	PMDA	
03H	Power Management 4	0	LVDTM[2:0]			CPMODE[1:0]		PMHPR	PMHPL	
04H	Output Mode Setting	0	0	VDDTM[3:0]				HPRHZ	HPLHZ	
05H	Clock Mode Select	0	CM[1:0]			FS[4:0]				
06H	Digital Filter Select	DASD	DASL	0	0	T1	0	NGT	NGDIS	
07H	DAC Mono Mixing	INVR	MDACR	RDACR	LDACR	INVL	MDACL	RDACL	LDACL	
08H	Reserved	0	0	0	0	0	0	0	0	
09H	Reserved	0	0	0	0	0	0	0	0	
0AH	Reserved	0	0	0	0	0	0	0	0	
0BH	Lch Output Volume	OVOLCN	0	0	OVL[4:0]					
0CH	Rch Output Volume	0	0	0	OVR[4:0]					
0DH	HP Volume Control	0	0	0	0	HPG[3:0]				
0EH	PLL CLK Source Select	0	0	T2	0	0	0	PLS[1:0]		
0FH	PLL Ref CLK Divider 1	PLD[15:8]								
10H	PLL Ref CLK Divider 2	PLD[7:0]								
11H	PLL FB CLK Divider 1	PLM[15:8]								
12H	PLL FB CLK Divider 2	PLM[7:0]								
13H	DAC CLK Source	0	0	0	0	0	0	DACCKS[1:0]		
14H	DAC CLK Divider	MDIV[7:0]								
15H	Audio I/F Format	DEVICEID[2:0]			MS	BCKO	DIF	DL[1:0]		
21H	CHIP ID	0	T101	T100	0	0	CHIPID[2:0]			
24H	Mode Control	0	DSMLP	0	T3	0	0	0	0	
26H	DAC Adjustment1	T11	T10	T9	T8	T7	T6	T5	T4	
2AH	DAC Adjustment2	T19	T18	T17	T16	T15	T14	T13	T12	

Note 76. PDN pin = "L" resets the registers to their default values.

Note 77. The bits defined as "0" must contain a "0" value.

Note 78. Writing access from 16H to 20H, 22H, 23H, 25H, 27H to 29H and 2BH to FFH is prohibited.



## ■ Register Definitions

Addr	Register Name	D7	D6	D5	D4	D3	D2	D1	D0
00H	Power Management 1	0	0	0	PMOSC	0	0	0	PMPLL
	R/W	R	R	R	R/W	R	R	R	R/W
	Default	0	0	0	0	0	0	0	0

PMPLL: PLL Power Management

0: Power-Down (default)

1: Power-Up

PMOSC: Crystal Oscillator Power Management

0: Power-Down (default)

1: Power-Up

Addr	Register Name	D7	D6	D5	D4	D3	D2	D1	D0
01H	Power Management 2	0	0	PMLDO1N	PMLDO1P	0	0	PMCP2	PMCP1
	R/W	R	R	R/W	R/W	R	R	R/W	R/W
	Default	0	0	0	0	0	0	0	0

PMCP1: Charge Pump 1 Power Management

0: Power-Down (default)

1: Power-Up

PMCP2: Charge Pump 2 Power Management

0: Power-Down (default)

1: Power-Up

PMLDO1P: LDO1P Power Management

0: Power-Down (default)

1: Power-Up

PMLDO1N: LDO1N Power Management

0: Power-Down (default)

1: Power-Up

Addr	Register Name	D7	D6	D5	D4	D3	D2	D1	D0
02H	Power Management 3	0	0	0	LPMODE	0	0	0	PMDA
	R/W	R	R	R	R/W	R	R	R	R/W
	Default	0	0	0	0	0	0	0	0

PMDA: DACDIG Power Management

0: Power-Down (default)

1: Power-Up

LPMODE: DAC & HP-Amp Low Power Mode Setting

0: High Performance Mode (default)

1: Low Power Mode

Addr	Register Name	D7	D6	D5	D4	D3	D2	D1	D0
03H	Power Management 4	0	LVDTM[2:0]			CPMODE[1:0]		PMHPR	PMHPL
	R/W	R	R/W			R/W		R/W	R/W
	Default	0	000			00		0	0

PMHPL/R: HP-Amp L/Rch Power Management

0: Power-Down (default)

1: Power-Up

CPMODE[1:0]: Charge Pump Mode Control ([Table 18](#))

Default: "00" (Automatic Switching Mode)

LVDTM[2:0]: Class-G 1/2VDD Mode Detection Time Setting ([Table 20](#))

Default: "000" (64/fs)

Addr	Register Name	D7	D6	D5	D4	D3	D2	D1	D0
04H	Output Mode Setting	0	0	VDDTM[3:0]				HPRHZ	HPLHZ
	R/W	R	R	R/W				R/W	R/W
	Default	0	0	0000				0	0

HPRHZ/HPLHZ: GND Switch Setting for HP-Amp Output

0: Pull-Down by 6Ω (Typ.) (default)

1: Pull-Down by 200 kΩ(Typ.)

VDDTM[3:0]: Class-G VDD Mode Hold Time Setting ([Table 19](#))

Default: "0000" (1024/fs)

Addr	Register Name	D7	D6	D5	D4	D3	D2	D1	D0
05H	Clock Mode Select	0	CM[1:0]		FS[4:0]				
	R/W	R	R/W		R/W				
	Default	0	00		0 0000				

FS[4:0]: Sampling Frequency Setting (Table 5)

Default: "00000" (fs = 8 kHz)

CM[1:0]: Master Clock Setting (Table 3, Table 4)

Default: "00" (256fs @Normal/Double Speed Mode / 32fs @Oct Speed Mode)

Addr	Register Name	D7	D6	D5	D4	D3	D2	D1	D0
06H	Digital Filter Select	DASD	DASL	0	0	T1	0	NGT	NGDIS
	R/W	R/W	R/W	R	R	R/W	R	R/W	R/W
	Default	0	0	0	0	0	0	0	0

NGDIS: Noise Gate Setting

0: Noise Gate Enable (default)

1: Noise Gate Disable

NGT: Noise Gate Timer Setting (Table 26)

Default: "0"

T1: Write "0" into this bit.

DASD, DASL: DAC Digital Filter Mode Setting (Table 14)

Default: "0, 0" (Sharp Roll-Off Filter)

Addr	Register Name	D7	D6	D5	D4	D3	D2	D1	D0
07H	DAC Mono Mixing	INVR	MDACR	RDACR	LDACR	INVL	MDACL	RDACL	LDACL
	R/W	R/W	R/W	R/W	R/W	R/W	R/W	R/W	R/W
	Default	0	0	0	0	0	0	0	0

MDACL, RDACL, LDACL: DAC Lch Input Signal Select (Table 15)

Default: "0, 0, 0" (MUTE)

MDACR, RDACR, LDACR: DAC Rch Input Signal Select (Table 15)

Default: "0, 0, 0" (MUTE)

INVL/R: DAC Input Signal Polarity Select

0: Normal (default)

1: Inverting

Addr	Register Name	D7	D6	D5	D4	D3	D2	D1	D0
08H 09H 0AH	Reserved	0	0	0	0	0	0	0	0
	R/W	R/W	R/W	R/W	R/W	R/W	R/W	R/W	R/W
	Default	0	0	0	0	0	0	0	0

Write "0" to the addresses from 08H to 0AH.

Addr	Register Name	D7	D6	D5	D4	D3	D2	D1	D0
0BH	Lch Output Volume	OVOLCN	0	0			OVL[4:0]		
0CH	Rch Output Volume	0	0	0			OVR[4:0]		
	R/W	R/W	R	R			R/W		
	Default	0	0	0			19H		

OVL[4:0]: DAC Lch Digital Volume Control; +3 dB to –12 dB & Mute, 0.5 dB step (Table 17)

OVR[4:0]: DAC Rch Digital Volume Control; +3 dB to –12 dB & Mute, 0.5 dB step (Table 17)

Default: “19H” (0 dB)

OVOLCN: Digital Volume Control

0: Dependent (default)

1: Independent

OVL[4:0] bits control digital volume of both L and R channels when OVOLCN bit = “0”. In this case, the value of OVL[4:0] bits will not be written to OVR[4:0] bits.

Addr	Register Name	D7	D6	D5	D4	D3	D2	D1	D0
0DH	HP Volume Control	0	0	0	0		HPG[3:0]		
	R/W	R	R	R	R		R/W		
	Default	0	0	0	0		BH		

HPG[3:0]: HP-Amp Analog Volume Control; +6 dB to –20 dB, 2 dB step (Table 21)

Default: BH (0 dB)

Addr	Register Name	D7	D6	D5	D4	D3	D2	D1	D0
0EH	PLL CLK Source Select	0	0	T2	0	0	0	PLS[1:0]	
	R/W	R	R	R/W	R	R	R	R/W	
	Default	0	0	0	0	0	0	00	

PLS[1:0]: PLL Clock Source Select (Table 7)

Default: “00” (MCKI pin)

T2: Write “0” into this bit.

Addr	Register Name	D7	D6	D5	D4	D3	D2	D1	D0
0FH	PLL Ref CLK Divider 1								PLD[15:8]
10H	PLL Ref CLK Divider 2								PLD[7:0]
	R/W								R/W
	Default								0000H

PLD[15:0]: PLL Reference Clock Divider Setting (Table 8)

Default: 0000H (Divided by 1)

Addr	Register Name	D7	D6	D5	D4	D3	D2	D1	D0
11H	PLL FB CLK Divider 1	PLM[15:8]							
12H	PLL FB CLK Divider 2	PLM[7:0]							
R/W		R/W							
Default		0000H							

PLM[15:0]: PLL Feedback Clock Divider Setting ([Table 9](#))

Default: 0000H (Clock Stop)

Addr	Register Name	D7	D6	D5	D4	D3	D2	D1	D0
13H	DAC CLK Source	0	0	0	0	0	0	DACCKS[1:0]	
R/W		R	R	R	R	R	R	R/W	
Default		0	0	0	0	0	0	00	

DACCKS[1:0]: DAC Master Clock Source Select ([Table 1](#))

Default: "00" (MCKI pin)

Addr	Register Name	D7	D6	D5	D4	D3	D2	D1	D0
14H	DAC CLK Divider	MDIV[7:0]							
R/W		R/W							
Default		00H							

MDIV[7:0]: DACMCLK Divider Setting ([Table 13](#))

Default: 00H (Divided by 1)

Addr	Register Name	D7	D6	D5	D4	D3	D2	D1	D0
15H	CODEC I/F Format	DEVICEID[2:0]			MS	BCKO	DIF	DL[1:0]	
R/W		R	R	R	R/W	R/W	R/W	R/W	
Default		0	1	0	0	0	0	00	

DL[1:0]: Data Length Setting ([Table 31](#))

Default: "00" (24-bit linear)

DIF: Digital I/F Format Setting ([Table 30](#))

Default: "0" (I<sup>2</sup>S Compatible)

BCKO: BCLK Output Frequency

0: 64fs (default)

1: 32fs

MS: Master/Slave Mode Setting

0: Slave Mode (default)

1: Master Mode

DEVICEID[2:0]: Device ID

Default: "010" (AK4376, AK4376A: "010")

Addr	Register Name	D7	D6	D5	D4	D3	D2	D1	D0
21H	CHIPID	0	T101	T100	0	0	CHIPID[2:0]		
R/W		R	R/W	R/W	R	R	R	R	R
Default		0	0	0	0	0	0	0	1

CHIPID[2:0]: CHIPID

Default: "001" (AK4376: "000", AK4376A: "001")

T101, T100: Write "0" into these bits.

Addr	Register Name	D7	D6	D5	D4	D3	D2	D1	D0
24H	Mode Control	0	DSMLP	0	T3	0	0	0	0
R/W		R	R/W	R	R/W	R	R	R	R
Default		0	0	0	0	0	0	0	0

DSMLP: DAC Operation Mode Setting (Table 3, Table 4)

Default: "0"

T3: Write "0" into this bit.

Addr	Register Name	D7	D6	D5	D4	D3	D2	D1	D0
26H	DAC Adjustment1	T11	T10	T9	T8	T7	T6	T5	T4
R/W		R/W	R/W	R/W	R/W	R/W	R/W	R/W	R/W
Default		0	1	0	0	0	0	0	0

\*\*"20H" data must be written to DAC Adjustment1 (Addr.26H) before analog blocks (CP1, CP2, LDO1, DAC, HP-Amp, PLL) are powered up

Addr	Register Name	D7	D6	D5	D4	D3	D2	D1	D0
2AH	DAC Adjustment2	T19	T18	T17	T16	T15	T14	T13	T12
R/W		R/W	R/W	R/W	R/W	R/W	R/W	R/W	R/W
Default		0	0	0	0	0	0	0	0

T19, T18, T17, T16: Write "0" into these bits

T15, T14, T13, T12: DAC Adjustment Setting

Default: "0000"

\*Write "05H" to DAC Adjustment2 (Addr.2AH) before the analog block (CP1, CP2, LDO1, DAC, HP-Amp, PLL) is powered up.

\*Recommended setting of DAC Adjustment2 (Addr.2AH) is "05H" data.

However, T[15:12] bits setting should be changed appropriately since the optimum setting for T[15:12] bits varies depending on the PCB layout.

**10. Recommended External Circuits**

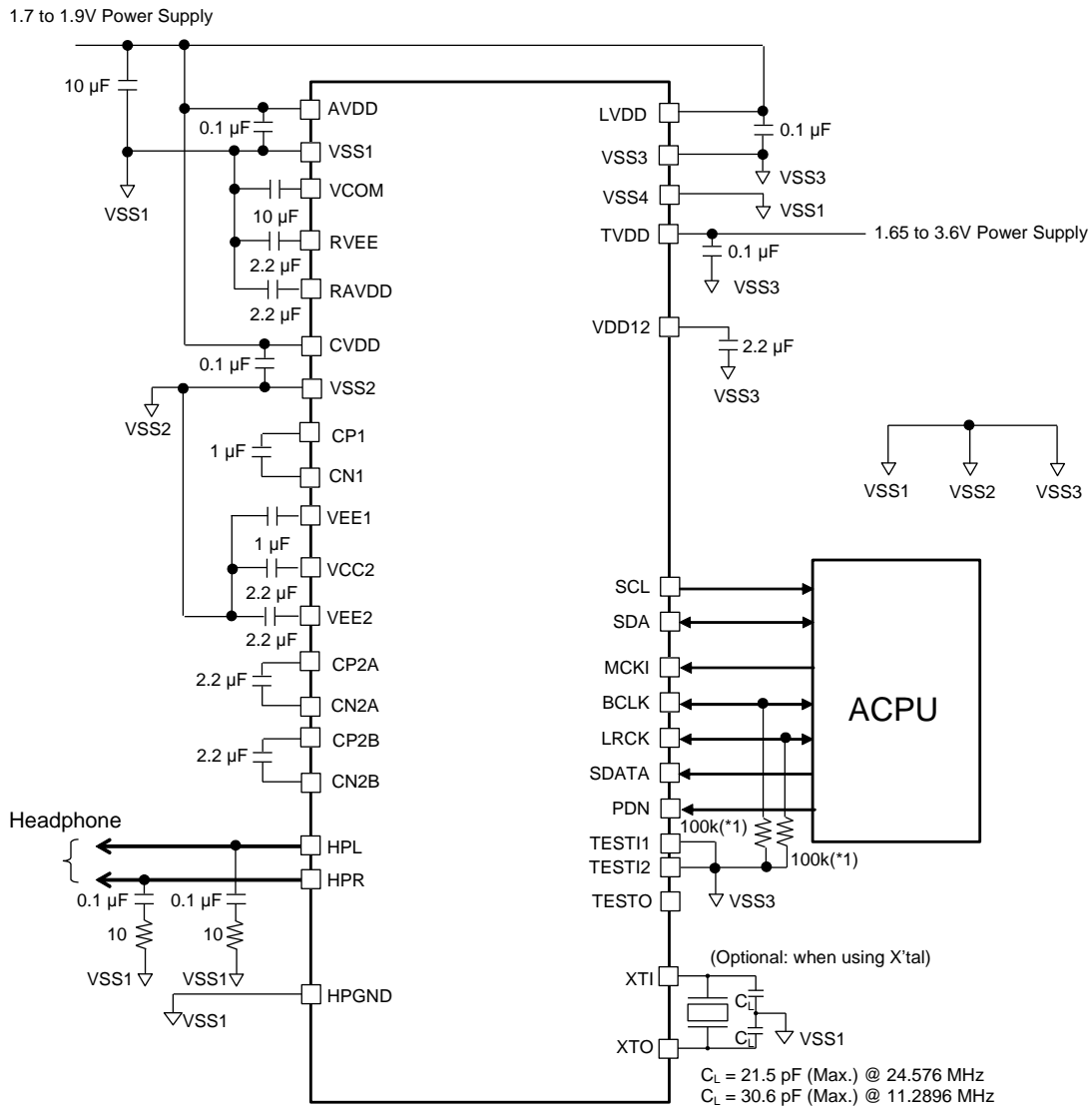

Figure 31. System Connection Diagram

\*1: When the AK4376A is in master mode, a pull-down resistor (e.g. 100 kΩ) is needed.

## 1. Grounding and Power Supply Decoupling

The AK4376A requires careful attention to power supply and grounding arrangements. The PDN pin should be held “L” when power supplies are tuning on. AVDD should be powered up before or at the same time of CVDD. Power-up sequence of TVDD and LVDD is not critical. The PDN pin is allowed to be “H” after all power supplies are applied and settled. To power down the AK4376A, set the PDN pin to “L” and power down CVDD before or at the same time of AVDD. Power-down sequence of LVDD and TVDD is not critical.

To avoid pop noise on analog output when power up/down, the AK4376A should be operated along the following recommended power-up/down sequence.

### 1) Power-up

- The PDN pin should be held “L” when power supplies are turning on. The AK4376A can be reset by keeping the PDN pin “L” for 1 ms or longer after all power supplies are applied and settled. Then release the reset by setting the PDN pin to “H”.

### 2) Power-down

- Each of power supplies can be powered OFF after the PDN pin is set to “L”.

VSS1, VSS2, VSS3 and VSS4 of the AK4376A should be connected to the analog ground plane. System analog ground and digital ground should be connected together near where the supplies are brought onto the printed circuit board. Decoupling capacitors should be as close the power supply pins as possible. Especially, the small value ceramic capacitor is to be closest.

## 2. Voltage Reference

VCOM is a common voltage of this chip. A 10  $\mu\text{F}$  ceramic capacitor attached between the VCOM pin eliminates the effects of high frequency noise. No load current is allowed to be drawn from the VCOM pin. All signals, especially clocks, should be kept away from the VCOM pin in order to avoid unwanted coupling into the AK4376A.

## 3. Charge Pump and LDO Circuits

Capacitors for CP1 block (connected between the CP1 pin and the CN1 pin, between the VEE1 pin and the VSS2 pin) should be low ESR 1.0  $\mu\text{F}$   $\pm 50\%$ . Capacitors for LDO1 block (connected between the RAVDD pin and the VSS1 pin, between the RVEE pin and the VSS1 pin) should be low ESR from 1.0  $\mu\text{F}$   $\pm 50\%$  to 4.7  $\mu\text{F}$   $\pm 50\%$ .

Capacitors for CP2 block (connected between the CP2A pin and the CN2A pin, between the CP2B pin and the CN2B pin, between the VCC2 pin and the VSS2 pin, between the VEE2 pin and the VSS2 pin) should be low ESR 2.2  $\mu\text{F}$   $\pm 50\%$ . These capacitors must be connected as close as possible to the pins. No load current may be drawn from the Positive / Negative Power Output pin (VEE1, RAVDD, RVEE, VCC2 and VEE2 pins).

## 4. Analog Outputs

Headphone outputs are single-ended and centered at HPGND (0 V). A headphone can be driven directly since a capacitor for AC coupling is not necessary.



**11. Package**

■ **Outline Dimensions**

**36-pin CSP (Unit: mm)**

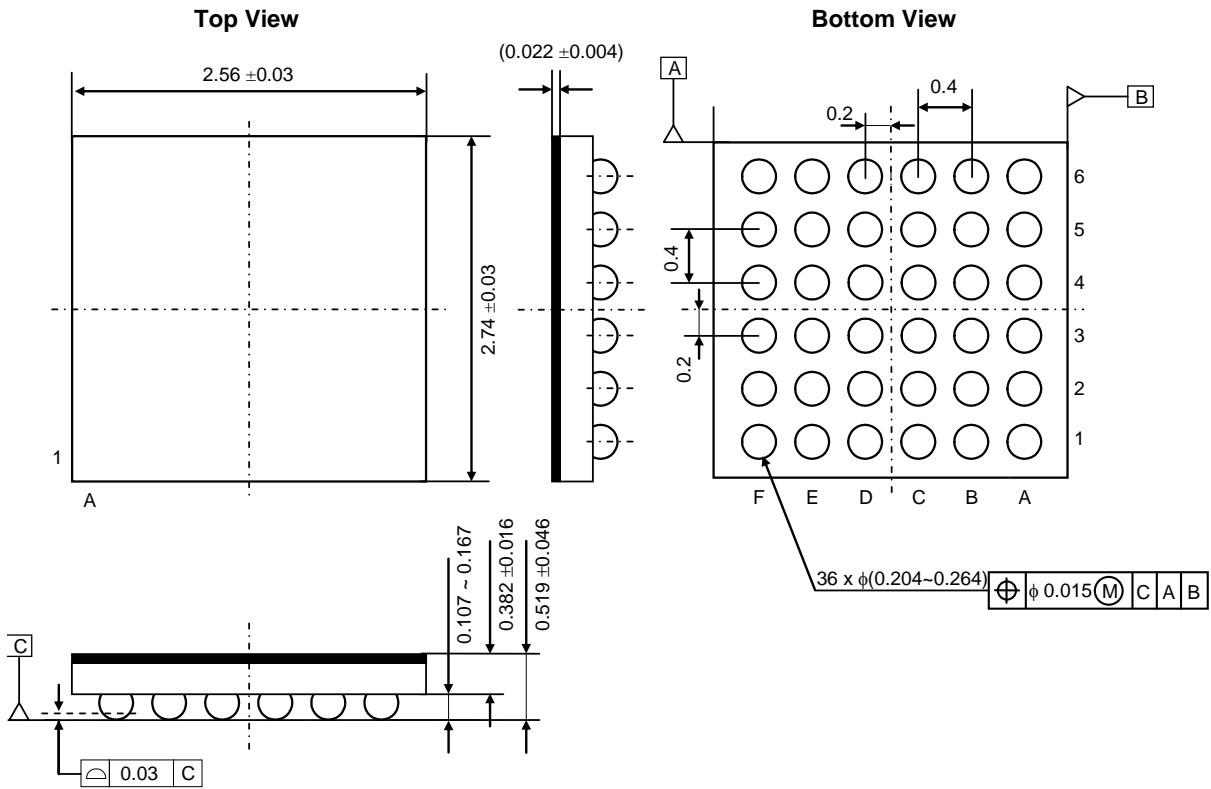

■ **Material and Lead Finish**

Package molding compound: Epoxy Resin, Halogen Free  
 Lead frame material: SnAgCu

■ **Marking**

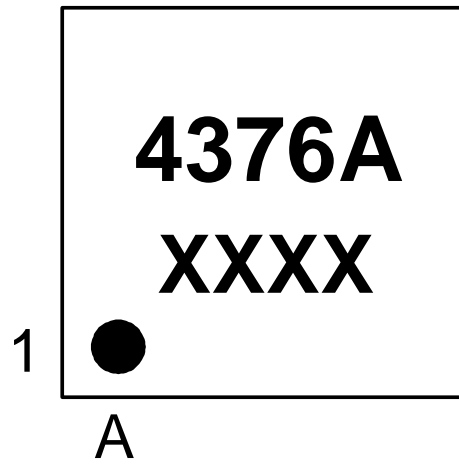

XXXX: Date code (4 digits)  
Pin #A1 indication

**12. Ordering Guide**

AK4376AECB    -40 to 85 °C    36-pin CSP (0.4 mm pitch)  
AKD4376A      Evaluation board for AK4376A

**13. Revision History**

Date (Y/M/D)	Revision	Reason	Page	Contents
16/11/09	00	First Edition		

## IMPORTANT NOTICE

0. Asahi Kasei Microdevices Corporation ("AKM") reserves the right to make changes to the information contained in this document without notice. When you consider any use or application of AKM product stipulated in this document ("Product"), please make inquiries the sales office of AKM or authorized distributors as to current status of the Products.
1. All information included in this document are provided only to illustrate the operation and application examples of AKM Products. AKM neither makes warranties or representations with respect to the accuracy or completeness of the information contained in this document nor grants any license to any intellectual property rights or any other rights of AKM or any third party with respect to the information in this document. You are fully responsible for use of such information contained in this document in your product design or applications. AKM ASSUMES NO LIABILITY FOR ANY LOSSES INCURRED BY YOU OR THIRD PARTIES ARISING FROM THE USE OF SUCH INFORMATION IN YOUR PRODUCT DESIGN OR APPLICATIONS.
2. The Product is neither intended nor warranted for use in equipment or systems that require extraordinarily high levels of quality and/or reliability and/or a malfunction or failure of which may cause loss of human life, bodily injury, serious property damage or serious public impact, including but not limited to, equipment used in nuclear facilities, equipment used in the aerospace industry, medical equipment, equipment used for automobiles, trains, ships and other transportation, traffic signaling equipment, equipment used to control combustions or explosions, safety devices, elevators and escalators, devices related to electric power, and equipment used in finance-related fields. Do not use Product for the above use unless specifically agreed by AKM in writing.
3. Though AKM works continually to improve the Product's quality and reliability, you are responsible for complying with safety standards and for providing adequate designs and safeguards for your hardware, software and systems which minimize risk and avoid situations in which a malfunction or failure of the Product could cause loss of human life, bodily injury or damage to property, including data loss or corruption.
4. Do not use or otherwise make available the Product or related technology or any information contained in this document for any military purposes, including without limitation, for the design, development, use, stockpiling or manufacturing of nuclear, chemical, or biological weapons or missile technology products (mass destruction weapons). When exporting the Products or related technology or any information contained in this document, you should comply with the applicable export control laws and regulations and follow the procedures required by such laws and regulations. The Products and related technology may not be used for or incorporated into any products or systems whose manufacture, use, or sale is prohibited under any applicable domestic or foreign laws or regulations.
5. Please contact AKM sales representative for details as to environmental matters such as the RoHS compatibility of the Product. Please use the Product in compliance with all applicable laws and regulations that regulate the inclusion or use of controlled substances, including without limitation, the EU RoHS Directive. AKM assumes no liability for damages or losses occurring as a result of noncompliance with applicable laws and regulations.
6. Resale of the Product with provisions different from the statement and/or technical features set forth in this document shall immediately void any warranty granted by AKM for the Product and shall not create or extend in any manner whatsoever, any liability of AKM.
7. This document may not be reproduced or duplicated, in any form, in whole or in part, without prior written consent of AKM.