



### GENERAL DESCRIPTION

The AK4589 is a single chip CODEC that includes two channels of ADC and eight channels of DAC. The ADC outputs 24bit data and the DAC accepts up to 24bit input data. The ADC has the Enhanced Dual Bit architecture with wide dynamic range. The DAC introduces the new developed Advanced Multi-Bit architecture, and achieves wider dynamic range and lower outband noise. The AK4589 has a dynamic range of 102dB for ADC, 114dB for DAC and is well suited for digital surround for home theater audio. The AK4589 also has the balance volume control corresponding to the Dolby Digital (AC-3) system.

The also has digital audio receiver (DIR) and transmitter (DIT) compatible with 192kHz, 24bits. The DIR has 8-channel input selector and can automatically detect a Non-PCM bit stream. The AK4589 provides a compatibility of hardware and software with the AK4588.

\*Dolby Digital (AC-3) is a trademark of Dolby Laboratories.

### FEATURES

#### □ ADC/DAC part

- **2ch 24bit ADC**
  - 64x Oversampling
  - Sampling Rate up to 96kHz
  - Linear Phase Digital Anti-Alias Filter
  - Single-Ended Input
  - S/(N+D): 92dB
  - Dynamic Range, S/N: 102dB
  - Digital HPF for offset cancellation
  - Overflow flag
- **8ch 24bit DAC**
  - 128x Oversampling
  - Sampling Rate up to 192kHz
  - 24bit 8 times Digital Filter
  - Differential Outputs
  - On-chip Switched-Capacitor Filter
  - S/(N+D): 94dB
  - Dynamic Range, S/N: 114dB
  - Individual channel digital volume with 128 levels and 0.5dB step
  - Soft mute
  - De-emphasis for 32kHz, 44.1kHz, 48kHz
  - Zero Detect Function
- **High Jitter Tolerance**
- **External Master Clock Input:**
  - 256fs, 384fs, 512fs (fs=32kHz ~ 48kHz)
  - 128fs, 192fs, 256fs (fs=64kHz ~ 96kHz)
  - 128fs (fs=120kHz ~ 192kHz)

DIR/DIT Part

- AES3, IEC60958, S/PDIF, EIAJ CP1201 Compatible
- Low jitter Analog PLL
- PLL Lock Range : 32kHz to 192kHz
- Clock Source: PLL or X'tal
- 8-channel Receiver input
- 2-channel Transmission output (Through output or DIT)
- Auxiliary digital input
- De-emphasis for 32kHz, 44.1kHz, 48kHz and 96kHz
- Detection Functions
  - Non-PCM Bit Stream Detection
  - DTS-CD Bit Stream Detection
  - Sampling Frequency Detection  
(32kHz, 44.1kHz, 48kHz, 88.2kHz, 96kHz, 176.4kHz, 192kHz)
  - Unlock & Parity Error Detection
  - Validity Flag Detection
- Up to 24bit Audio Data Format
- Audio I/F: Master or Slave Mode
- 40-bit Channel Status Buffer
- Burst Preamble bit Pc and Pd Buffer for Non-PCM bit stream
- Q-subcode Buffer for CD bit stream
- Serial  $\mu$ P I/F
- Two Master Clock Outputs: 64fs/128fs/256fs/512fs

 TTL Level Digital I/F

- 4-wire Serial and I<sup>2</sup>C Bus  $\mu$ P I/F for mode setting
- Operating Voltage: 4.75 to 5.25V with 5V tolerance
- Power Supply for output buffer: 2.7 to 5.25V
- 80pin LQFP Package (0.5mm pitch)
- AK4588 compatible w/o analog outputs

■ Block Diagram

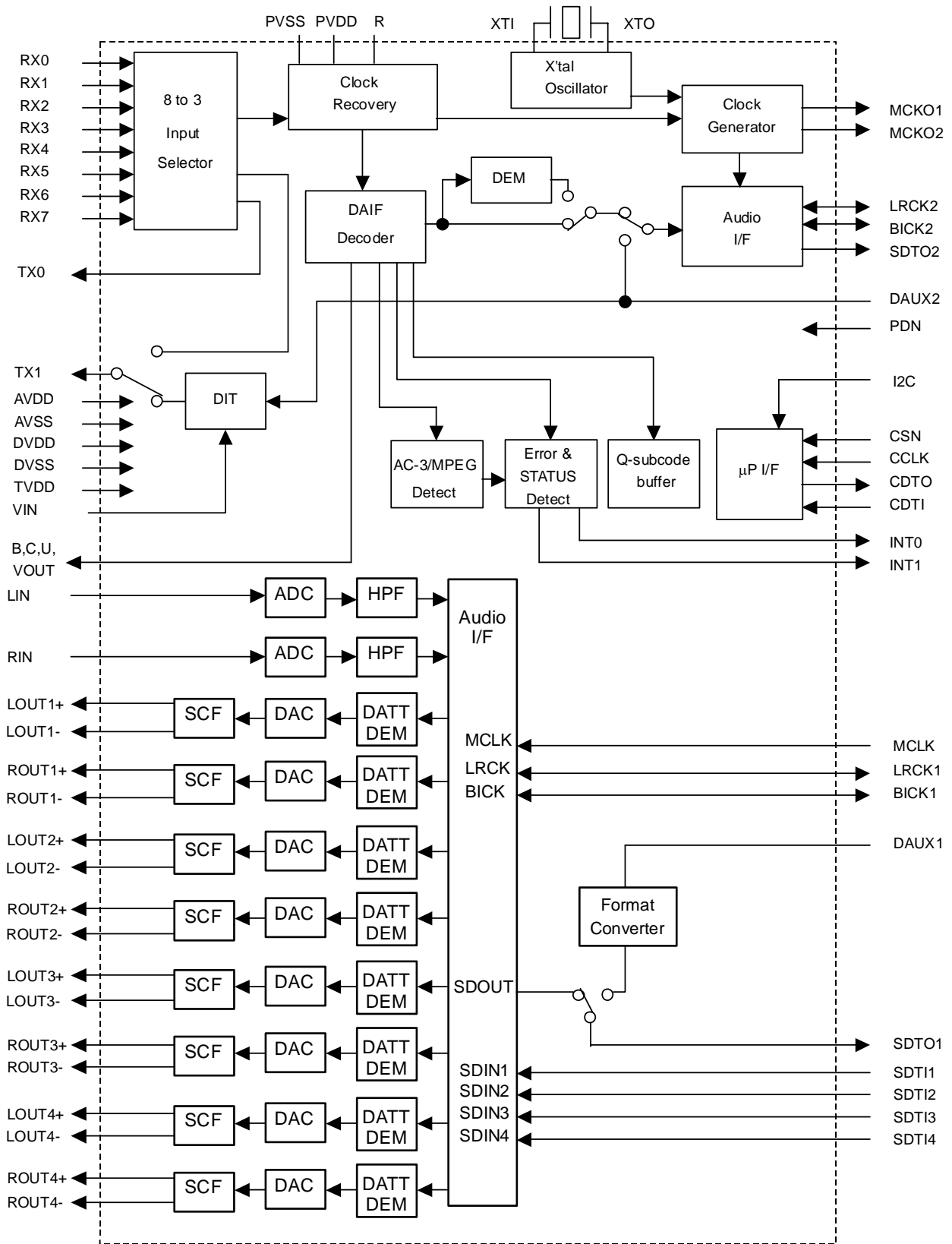

■ Ordering Guide

AK4589VQ      -10 ~ +70°C      80pin LQFP(0.5mm pitch)  
 AKD4589      Evaluation Board for AK4589

■ Pin Layout

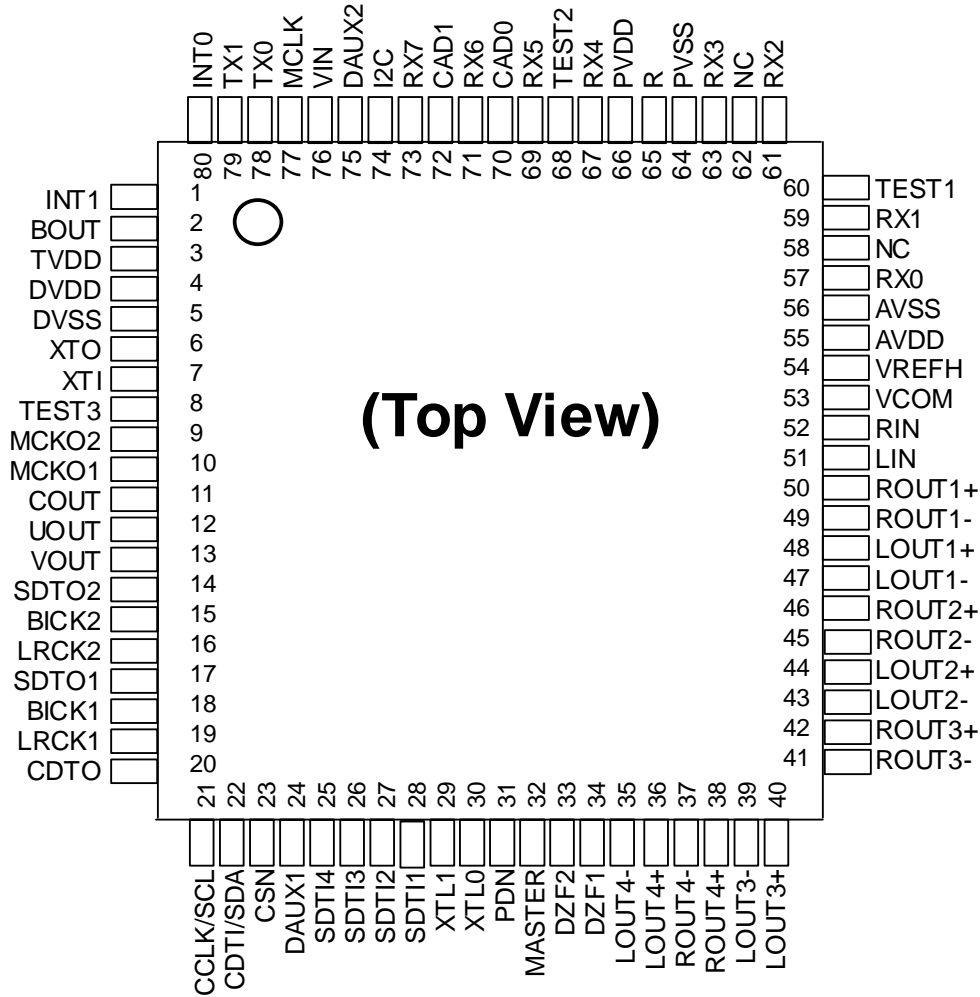

### ■ Compatibility with AK4588

Functions	AK4588	AK4589
DAC output	Single end	Differential
DAC S/(N+D)	90dB	94dB
DAC S/N	106dB	114dB
DAC Output voltage	Typ 3.0Vpp	Typ $\pm 2.7$ Vpp
DAC AOUT	AOUT=0.6xVREFH	AOUT=0.54xVREFH
Load Resistance	5k ohm	2k ohm
Frequency Response 80kHz	$\pm 1.0$	+0/-0.6
Output pin	#35,#37, #39,#41,#43,#45,#47,#49	#35 - #50
Power Supply voltage	Min=4.5V, Max=5.5V	Min=4.75V, Max=5.25V

(\*) The AK4589 has two register maps including ADC/DAC part (compatible with the AK4588) and DIR/DIT part (compatible with AK4588). Each register is selected by Chip Address.

PIN/FUNCTION			
No.	Pin Name	I/O	Function
1	INT1	O	Interrupt 1 Pin
2	BOUT	O	Block-Start Output Pin for Receiver Input "H" during first 40 frames.
3	TVDD	-	Output Buffer Power Supply Pin, 2.7V~5.25V
4	DVDD	-	Digital Power Supply Pin, 4.75V~5.25V
5	DVSS	-	Digital Ground Pin
6	XTO	O	X'tal Output Pin
7	XTI	I	X'tal Input Pin
8	TEST3	I	Test 3 Pin This pin should be connected to DVSS.
9	MCKO2	O	Master Clock Output 2 Pin
10	MCKO1	O	Master Clock Output 1 Pin
11	COOUT	O	C-bit Output Pin for Receiver Input
12	UOUT	O	U-bit Output Pin for Receiver Input
13	VOOUT	O	V-bit Output Pin for Receiver Input
14	SDTO2	O	Audio Serial Data Output Pin (DIR/DIT part)
15	BICK2	I/O	Audio Serial Data Clock Pin (DIR/DIT part)
16	LRCK2	I/O	Channel Clock Pin (DIR/DIT part)
17	SDTO1	O	Audio Serial Data Output Pin (ADC/DAC part)
18	BICK1	I/O	Audio Serial Data Clock Pin (ADC/DAC part)
19	LRCK1	I/O	Input Channel Clock Pin
20	CDTO	O	Control Data Output Pin in Serial Mode, I2C= "L".
21	CCLK	I	Control Data Clock Pin in Serial Mode, I2C= "L"
	SCL	I	Control Data Clock Pin in Serial Mode, I2C= "H"
22	CDTI	I	Control Data Input Pin in Serial Mode, I2C= "L".
	SDA	I/O	Control Data Pin in Serial Mode, I2C= "H".
23	CSN	I	Chip Select Pin in Serial Mode, I2C= "L".
		I	This pin should be connected to DVSS, I2C= "H".
24	DAUX1	I	AUX Audio Serial Data Input Pin (ADC/DAC part)
25	SDTI4	I	DAC4 Audio Serial Data Input Pin
26	SDTI3	I	DAC3 Audio Serial Data Input Pin
27	SDTI2	I	DAC2 Audio Serial Data Input Pin
28	SDTI1	I	DAC1 Audio Serial Data Input Pin
29	XTL1	I	X'tal Frequency Select 0 Pin
30	XTL0	I	X'tal Frequency Select 1 Pin

No.	Pin Name	I/O	Function
31	PDN	I	Power-Down Mode Pin When "L", the AK4589 is powered-down, all digital output pins go "L", all registers are reset. When CAD1/0 pins are changed, the AK4589 should be reset by PDN pin.
32	MASTER	I	Master Mode Select Pin "H": Master mode, "L": Slave mode
33	DZF2	O	Zero Input Detect 2 Pin (Table 13) When the input data of the group 1 follow total 8192 LRCK cycles with "0" input data, this pin goes to "H". And when RSTN bit is "0", PWDAN bit is "0", this pin goes to "H". It always is in "L" when P/S pin is "H".
	OVF	O	Analog Input Overflow Detect Pin This pin goes to "H" if the analog input of Lch or Rch overflows.
34	DZF1	O	Zero Input Detect 1 Pin (Table 13) When the input data of the group 1 follow total 8192 LRCK cycles with "0" input data, this pin goes to "H". And when RSTN bit is "0", PWDAN bit is "0", this pin goes to "H". Output is selected by setting DZFE pin when P/S pin is "H".
35	LOUT4-	O	DAC4 Lch Negative Analog Output Pin
36	LOUT4+	O	DAC4 Lch Positive Analog Output Pin
37	ROUT4-	O	DAC4 Rch Negative Analog Output Pin
38	ROUT4+	O	DAC4 Rch Positive Analog Output Pin
39	LOUT3-	O	DAC3 Lch Negative Analog Output Pin
40	LOUT3+	O	DAC3 Lch Positive Analog Output Pin
41	ROUT3-	O	DAC3 Rch Negative Analog Output Pin
42	ROUT3+	O	DAC3 Rch Positive Analog Output Pin
43	LOUT2-	O	DAC2 Lch Negative Analog Output Pin
44	LOUT2+	O	DAC2 Lch Positive Analog Output Pin
45	ROUT2-	O	DAC2 Rch Negative Analog Output Pin
46	ROUT2+	O	DAC2 Rch Positive Analog Output Pin
47	LOUT1-	O	DAC1 Lch Negative Analog Output Pin
48	LOUT1+	O	DAC1 Lch Positive Analog Output Pin
49	ROUT1-	O	DAC1 Rch Negative Analog Output Pin
50	ROUT1+	O	DAC1 Rch Positive Analog Output Pin
51	LIN	I	Lch Analog Input Pin
52	RIN	I	Rch Analog Input Pin
53	VCOM	-	Common Voltage Output Pin 2.2 $\mu$ F capacitor should be connected to AVSS externally.
54	VREFH	-	Positive Voltage Reference Input Pin, AVDD

No.	Pin Name	I/O	Function
55	AVDD	-	Analog Power Supply Pin, 4.75V~5.25V
56	AVSS	-	Analog Ground Pin, 0V
57	RX0	I	Receiver Channel 0 Pin (Internal biased pin. Internally biased at PVDD/2)
58	NC	-	No Connect pin No internal bonding. This pin should be connected to PVSS.
59	RX1	I	Receiver Channel 1 Pin (Internal biased pin. Internally biased at PVDD/2)
60	TEST1	I	Test 1 Pin This pin should be connected to PVSS.
61	RX2	I	Receiver Channel 2 Pin (Internal biased pin. Internally biased at PVDD/2)
62	NC	-	No Connect pin No internal bonding. This pin should be connected to PVSS.
63	RX3	I	Receiver Channel 3 Pin (Internal biased pin. Internally biased at PVDD/2)
64	PVSS	-	PLL Ground pin
65	R	-	External Resistor Pin 12kΩ +/-1% resistor should be connected to PVSS externally.
66	PVDD	-	PLL Power supply Pin, 4.75V~5.25V
67	RX4	I	Receiver Channel 4 Pin (Internal biased pin. Internally biased at PVDD/2)
68	TEST2	I	Test 2 Pin This pin should be connected to PVSS.
69	RX5	I	Receiver Channel 5 Pin (Internal biased pin. Internally biased at PVDD/2)
70	CAD0	I	Chip Address 0 Pin (ADC/DAC part)
71	RX6	I	Receiver Channel 6 Pin (Internal biased pin. Internally biased at PVDD/2)
72	CAD1	I	Chip Address 1 Pin (ADC/DAC part)
73	RX7	I	Receiver Channel 7 Pin (Internal biased pin. Internally biased at PVDD/2)
74	I2C	I	Control Mode Select Pin. “L”: 4-wire Serial, “H”: I <sup>2</sup> C Bus
75	DAUX2	I	Auxiliary Audio Data Input Pin (DIR/DIT part)
76	VIN	I	V-bit Input Pin for Transmitter Output
77	MCLK	I	Master Clock Input Pin
78	TX0	O	Transmit Channel (Through Data) Output 0 Pin
79	TX1	O	Transmit Channel Output1 pin When DIT bit = “0”, Through Data. When DIT bit = “1”, DAUX2 Data.
80	INT0	O	Interrupt 0 Pin

Note: All input pins except internal biased pins and Analog input pins (RX0-7, LIN, RIN) should not be left floating.

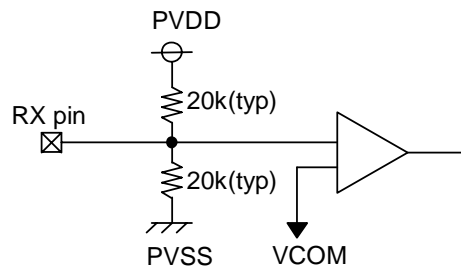

Internal biased pin Circuit



### ■ Handling of Unused Pin

The unused I/O pins should be processed appropriately as below.

Classification	Pin Name	Setting
Analog	RX0-7, LOUT1-4, ROUT1-4, LIN, RIN	These pins should be open.
Digital	INT0-1, BOUT, XTO, MCKO1-2, COUT, UOUT, VOUT, SDTO1-2, CDTO, DZF1-2, TX1-0	These pins should be open.
	CSN, DAUX1-2, SDTI1-4, XTL0-1	These pins should be connected to DVSS.
	TEST1-3	These pins should be connected to PVSS.

<b>ABSOLUTE MAXIMUM RATINGS</b>
---------------------------------

(AVSS, DVSS, PVSS=0V; Note 1)

Parameter		Symbol	min	max	Units
Power Supplies	Analog	AVDD	-0.3	6.0	V
	Digital	DVDD	-0.3	6.0	V
	PLL	PVDD	-0.3	6.0	V
	Output buffer	TVDD	-0.3	6.0	V
	AVSS-DVSS  (Note 2)	ΔGND1	-	0.3	V
	AVSS-PVSS  (Note 2)	ΔGND2	-	0.3	V
Input Current (any pins except for supplies)		IIN	-	±10	mA
Analog Input Voltage (LIN, RIN pins)		VINA	-0.3	AVDD+0.3	V
Digital Input Voltage					
	Except LRCK1-2, BICK1-2, RX0-7, CAD0-1, TEST1-2 pins	VIND1	-0.3	DVDD+0.3	V
	LRCK1-2, BICK1-2 pins	VIND2	-0.3	TVDD+0.3	V
	RX0-7, CAD0-1, TEST1-2 pins	VIND3	-0.3	PVDD+0.3	V
Ambient Temperature (power applied)		Ta	-10	70	°C
Storage Temperature		Tstg	-65	150	°C

Notes:

1. All voltages with respect to ground.
2. AVSS, DVSS and PVSS must be connected to the same analog ground plane.

WARNING: Operation at or beyond these limits may result in permanent damage to the device.  
Normal operation is not guaranteed at these extremes.

<b>RECOMMENDED OPERATING CONDITIONS</b>
---

(AVSS, DVSS, PVSS=0V; Note 3)

Parameter		Symbol	min	typ	max	Units
Power Supplies (Note 4)	Analog	AVDD	4.75	5.0	5.25	V
	Digital	DVDD	4.75	5.0	AVDD	V
	PLL	PVDD	4.75	5.0	AVDD	V
	Output buffer	TVDD	2.7	5.0	DVDD	V

Notes:

3. All voltages with respect to ground.
4. The power up sequence between AVDD, DVDD, PVDD and TVDD is not critical. To save leak current in power down mode, AVDD, DVDD, PVDD become the same voltage as much as possible.

WARNING: AKM assumes no responsibility for the usage beyond the conditions in this datasheet.

<b>ANALOG CHARACTERISTICS</b>
-------------------------------

(Ta=25°C; AVDD, DVDD, PVDD, TVDD=5V; AVSS, DVSS=0V; VREFH=AVDD; fs=48kHz; BICK=64fs;  
Signal Frequency=1kHz; 24bit Data; Measurement Frequency=20Hz~20kHz at fs=48kHz, 20Hz~40kHz at fs=96kHz;  
20Hz~40kHz at fs=192kHz, unless otherwise specified)

Parameter		min	typ	max	Units
<b>ADC Analog Input Characteristics</b>					
Resolution				24	Bits
S/(N+D) (-0.5dBFS)	fs=48kHz	84	92		dB
	fs=96kHz	-	86		dB
DR (-60dBFS)	fs=48kHz, A-weighted	94	102		dB
	fs=96kHz	88	96		dB
	fs=96kHz, A-weighted	93	102		dB
S/N (Note 5)	fs=48kHz, A-weighted	93	102		dB
	fs=96kHz	88	96		dB
	fs=96kHz, A-weighted	93	102		dB
Interchannel Isolation		90	110		dB
<b>DC Accuracy</b>					
Interchannel Gain Mismatch			0.2	0.3	dB
Gain Drift			20	-	ppm/°C
Input Voltage	A <sub>IN</sub> =0.62xVREFH	2.90	3.10	3.30	V <sub>pp</sub>
Input Resistance	fs=48kHz	15	25		kΩ
	fs=96kHz	9	16		kΩ
Power Supply Rejection	(Note 7)		50		dB
<b>DAC Analog Output Characteristics</b>					
Resolution				24	Bits
S/(N+D)	fs=48kHz	86	94		dB
	fs=96kHz	84	92		dB
	fs=192kHz	-	92		dB
DR (-60dBFS)	fs=48kHz, A-weighted	104	114		dB
	fs=96kHz	98	108		dB
	fs=96kHz, A-weighted	104	114		dB
	fs=192kHz	-	108		dB
	fs=192kHz, A-weighted	-	114		dB
S/N (Note 8)	fs=48kHz, A-weighted	104	114		dB
	fs=96kHz	98	108		dB
	fs=96kHz, A-weighted	104	114		dB
	fs=192kHz	-	108		dB
	fs=192kHz, A-weighted	-	114		dB
Interchannel Isolation		90	100		dB
<b>DC Accuracy</b>					
Interchannel Gain Mismatch			0.2	0.5	dB
Gain Drift			20	-	ppm/°C
Output Voltage	A <sub>OUT</sub> =0.54xVREFH	±2.5	±2.7	±2.9	V <sub>pp</sub>
Load Resistance	(AC Load) (Note 6)	2			kΩ
Power Supply Rejection	(Note 7)		50		dB
<b>Power Supplies</b>					
Power Supply Current					
Normal Operation (PDN = "H") (Note 9)	AVDD	fs=48kHz, fs=96kHz	70	98	mA
		fs=192kHz	57	80	mA
	PVDD		12	17	mA
DVDD+TVDD (Note 10)	fs=48kHz		44	62	mA
	fs=96kHz		57	80	mA
	fs=192kHz		68	95	mA
Power-down mode (PDN pin = "L") (Note 11)			0.1	1	mA

## Notes:

5. S/N measured by CCIR-ARM is 96dB(@fs=48kHz).
6. For AC-load. 4kΩ for DC-load
7. PSR is applied to AVDD, DVDD, PVDD and TVDD with 1kHz, 50mVpp. VREFH pin is held a constant voltage.
8. S/N measured by CCIR-ARM is 102dB(@fs=48kHz).
9.  $C_L=20\text{pF}$ ,  $X'tal=24.576\text{MHz}$ , CM1-0="10", CM1-0="10", OCKS1-0="10"@48kHz, "00"@96kHz, "11"@192kHz.
10. TVDD=13mA(typ).
11. In the power-down mode. RX inputs are open and all digital input pins including clock pins (MCLK, BICK, LRCK) are held DVSS.

<b>FILTER CHARACTERISTICS</b>
-------------------------------

(Ta=25°C; AVDD, DVDD, PVDD=4.75~5.25V; TVDD=2.7~5.25V; fs=48kHz)

Parameter	Symbol	min	typ	max	Units		
<b>ADC Digital Filter (Decimation LPF):</b>							
Passband (Note 12)		±0.1dB	PB	0	18.9	kHz	
		-0.2dB		-	20.0	-	kHz
		-3.0dB		-	23.0	-	kHz
Stopband		SB	28.0		kHz		
Passband Ripple		PR		±0.04	dB		
Stopband Attenuation		SA	68		dB		
Group Delay (Note 13)		GD		16	1/fs		
Group Delay Distortion		ΔGD		0	μs		
<b>ADC Digital Filter (HPF):</b>							
Frequency Response (Note 12)		-3dB	FR		1.0	Hz	
		-0.1dB			6.5	Hz	
<b>DAC Digital Filter:</b>							
Passband (Note 12)		-0.1dB	PB	0	21.8	kHz	
		-6.0dB		-	24.0	-	kHz
Stopband		SB	26.2		kHz		
Passband Ripple		PR		±0.02	dB		
Stopband Attenuation		SA	54		dB		
Group Delay (Note 13)		GD		19.2	1/fs		
<b>DAC Digital Filter + Analog Filter:</b>							
Frequency Response:	0 ~ 20.0kHz	FR		±0.2	dB		
		FR		±0.3	dB		
		FR		+0/-0.6	dB		

## Notes:

12. The passband and stopband frequencies scale with fs.  
For example, 21.8kHz at -0.1dB is 0.454 x fs (DAC). The reference frequency of these responses is 1kHz.
13. The calculating delay time which occurred by digital filtering. This time is from setting the input of analog signal to setting the 24bit data of both channels to the output register for ADC.  
For DAC, this time is from setting the 20/24bit data of both channels on input register to the output of analog signal.
14. 40kHz@fs=96kHz, 80kHz@fs=192kHz

**DC CHARACTERISTICS**

(Ta=25°C; AVDD, DVDD, PVDD=4.75~5.25V; TVDD=2.7~5.25V)

Parameter	Symbol	min	typ	max	Units
High-Level Input Voltage (Except XTI pin)	VIH	2.2	-	-	V
	VIH	70% DVDD	-	-	V
Low-Level Input Voltage (Except XTI pin)	VIL	-	-	0.8	V
	VIL	-	-	30% DVDD	V
Input Voltage at AC Coupling (XTI pin) (Table 15)	VAC	40% DVDD	-	-	Vpp
High-Level Output Voltage (Except TX0-1, DZF pins: Iout=-400μA)	VOH	TVDD-0.4	-	-	V
	VOH	DVDD-0.4	-	-	V
	VOH	AVDD-0.4	-	-	V
Low-Level Output Voltage (Iout=400μA)	VOL	-	-	0.4	V
Input Leakage Current	Iin	-	-	±10	μA

Note:

- 15. In case of connecting capacitance (0.1μF) to XTI pin.

**S/PDIF RECEIVER CHARACTERISTICS**

(Ta=25°C; AVDD, DVDD, PVDD=4.75~5.25V; TVDD=2.7~5.25V)

Parameter	Symbol	min	typ	max	Units
Input Resistance	Zin		10		kΩ
Input Voltage (internally biased at PVDD/2)	VTH	200			mVpp
Input Hysteresis	VHY	-	50		mV
Input Sample Frequency	fs	32	-	192	kHz

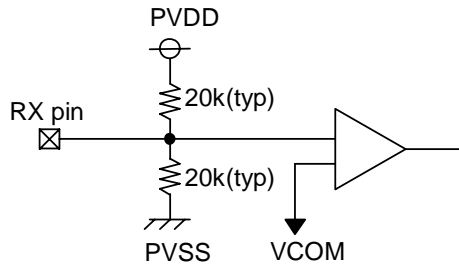

Internal biased pin Circuit

<b>SWITCHING CHARACTERISTICS (ADC/DAC part)</b>					
(Ta=25°C; AVDD, DVDD, PVDD=4.75~5.25V; TVDD=2.7~5.25V; CL=20pF)					
Parameter	Symbol	min	typ	max	Units
<b>Master Clock Timing</b>					
<b>Master Clock</b>					
256fsn, 128fsd:	fCLK	8.192		12.288	MHz
Pulse Width Low	tCLKL	27			ns
Pulse Width High	tCLKH	27			ns
384fsn, 192fsd:	fCLK	12.288		18.432	MHz
Pulse Width Low	tCLKL	20			ns
Pulse Width High	tCLKH	20			ns
512fsn, 256fsd, 128fsq:	fCLK	16.384		24.576	MHz
Pulse Width Low	tCLKL	15			ns
Pulse Width High	tCLKH	15			ns
<b>LRCK1 Timing (Slave Mode)</b>					
<b>Normal mode</b>					
Normal Speed Mode	fsn	32		48	kHz
Double Speed Mode	fsd	64		96	kHz
Quad Speed Mode	fsq	120		192	kHz
Duty Cycle	Duty	45		55	%
<b>TDM 256 mode</b>					
LRCK1 frequency	fsd	32		48	kHz
“H” time	tLRH	1/256fs			ns
“L” time	tLRL	1/256fs			ns
<b>TDM 128 mode</b>					
LRCK1 frequency	fsd	64		96	kHz
“H” time	tLRH	1/128fs			ns
“L” time	tLRL	1/128fs			ns
<b>LRCK1 Timing (Master Mode)</b>					
<b>Normal mode</b>					
Normal Speed Mode	fsn	32		48	kHz
Double Speed Mode	fsd	64		96	kHz
Quad Speed Mode	fsq	120		192	kHz
Duty Cycle	Duty		50		%
<b>TDM 256 mode</b>					
LRCK1 frequency	fsn	32		48	kHz
“H” time (Note 16)	tLRH		1/8fs		ns
<b>TDM 128 mode</b>					
LRCK1 frequency	fsd	64		96	kHz
“H” time (Note 16)	tLRH		1/4fs		ns
<b>Power-down &amp; Reset Timing</b>					
PDN Pulse Width (Note 17)	tPD	150			ns
PDN “↑” to SDTO1 valid (Note 18)	tPDV		522		1/fs

Notes:

16. “L” time at I<sup>2</sup>S format.

17. The AK4589 can be reset by bringing PDN “L” to “H” upon power-up.

18. These cycles are the number of LRCK rising from PDN rising.

Parameter	Symbol	min	typ	max	Units
<b>Audio Interface Timing (Slave Mode)</b>					
<b>Normal mode</b>					
BICK1 Period	tBCK	81			ns
BICK1 Pulse Width Low	tBCKL	32			ns
Pulse Width High	tBCKH	32			ns
LRCK1 Edge to BICK1 “↑” (Note 19)	tLRB	20			ns
BICK1 “↑” to LRCK1 Edge (Note 19)	tBLR	20			ns
LRCK1 to SDTO1(MSB)	tLRS			40	ns
BICK1 “↓” to SDTO1	tBSD			40	ns
SDTII-4,DAUX1 Hold Time	tSDH	20			ns
SDTII-4,DAUX1 Setup Time	tSDS	20			ns
<b>TDM 256 mode</b>					
BICK1 Period	tBCK	81			ns
BICK1 Pulse Width Low	tBCKL	32			ns
Pulse Width High	tBCKH	32			ns
LRCK1 Edge to BICK1 “↑” (Note 19)	tLRB	20			ns
BICK1 “↑” to LRCK1 Edge (Note 19)	tBLR	20			ns
BICK1 “↓” to SDTO1	tBSD			20	ns
SDTII Hold Time	tSDH	10			ns
SDTII Setup Time	tSDS	10			ns
<b>TDM 128 mode</b>					
BICK1 Period	tBCK	81			ns
BICK1 Pulse Width Low	tBCKL	32			ns
Pulse Width High	tBCKH	32			ns
LRCK1 Edge to BICK1 “↑” (Note 19)	tLRB	20			ns
BICK1 “↑” to LRCK1 Edge (Note 19)	tBLR	20			ns
BICK1 “↓” to SDTO1	tBSD			20	ns
SDTII-2 Hold Time	tSDH	10			ns
SDTII-2 Setup Time	tSDS	10			ns
<b>Audio Interface Timing (Master Mode)</b>					
<b>Normal mode</b>					
BICK1 Frequency	fBCK		64fs		Hz
BICK1 Duty	dBCK		50		%
BICK1 “↓” to LRCK1 Edge	tMBLR	-20		20	ns
BICK1 “↓” to SDTO1	tBSD			40	ns
SDTII-4,DAUX1 Hold Time	tSDH	20			ns
SDTII-4,DAUX1 setup Time	tSDS	20			ns
<b>TDM 256 mode</b>					
BICK1 Frequency (Note 20)	fBCK		256fs		Hz
BICK1 Duty (Note 20)	dBCK		50		%
BICK1 “↓” to LRCK1 Edge	tMBLR	-12		12	ns
BICK1 “↓” to SDTO1	tBSD			20	ns
SDTII Hold Time	tSDH	10			ns
SDTII Setup Time	tSDS	10			ns
<b>TDM 128 mode</b>					
BICK1 Frequency (Note 21)	fBCK		128fs		Hz
BICK1 Duty (Note 21)	dBCK		50		%
BICK1 “↓” to LRCK1 Edge	tMBLR	-12		12	ns
BICK1 “↓” to SDTO1	tBSD			20	ns
SDTII-2 Hold Time	tSDH	10			ns
SDTII-2 Setup Time	tSDS	10			ns

Notes:

19. BICK1 rising edge must not occur at the same time as LRCK1 edge.

20. When MCLK is 512fs, dBCK is guaranteed. When 384fs and 256fs, dBCK can not be guaranteed.

21. When MCLK is 256fs, dBCK is guaranteed. When 128fs, dBCK can not be guaranteed.

■ Timing Diagram(ADC/DAC part)

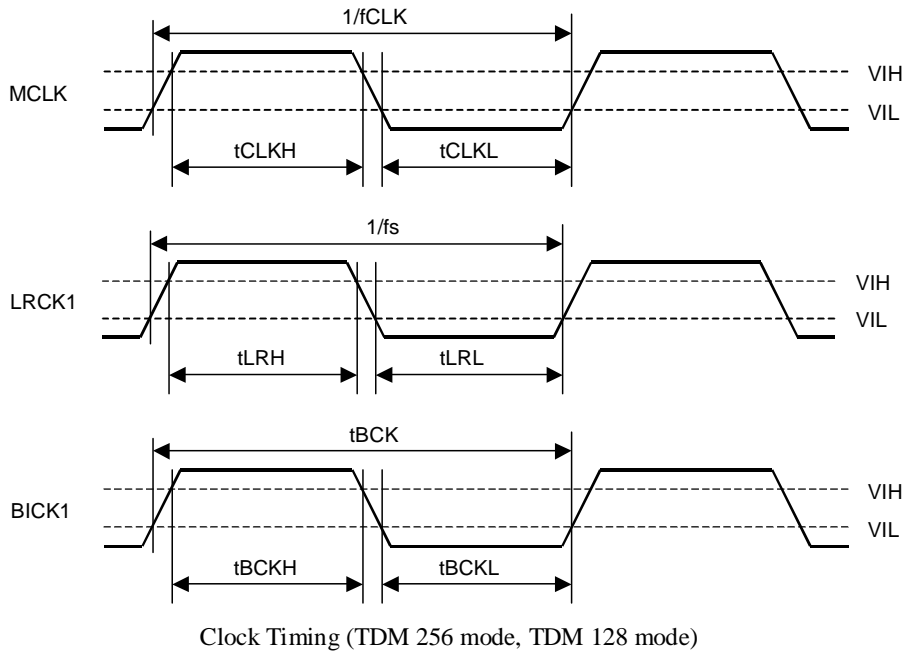
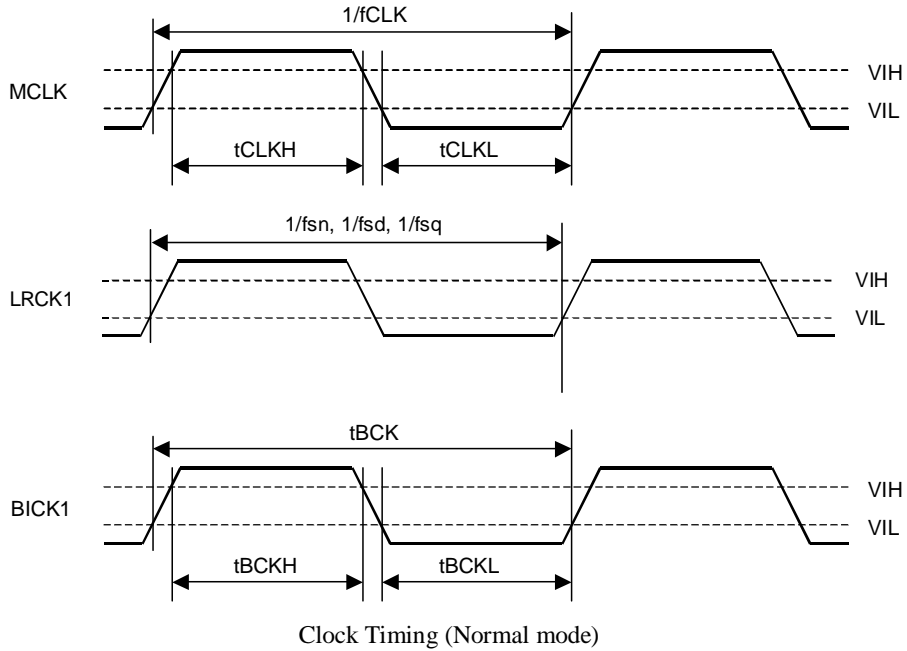



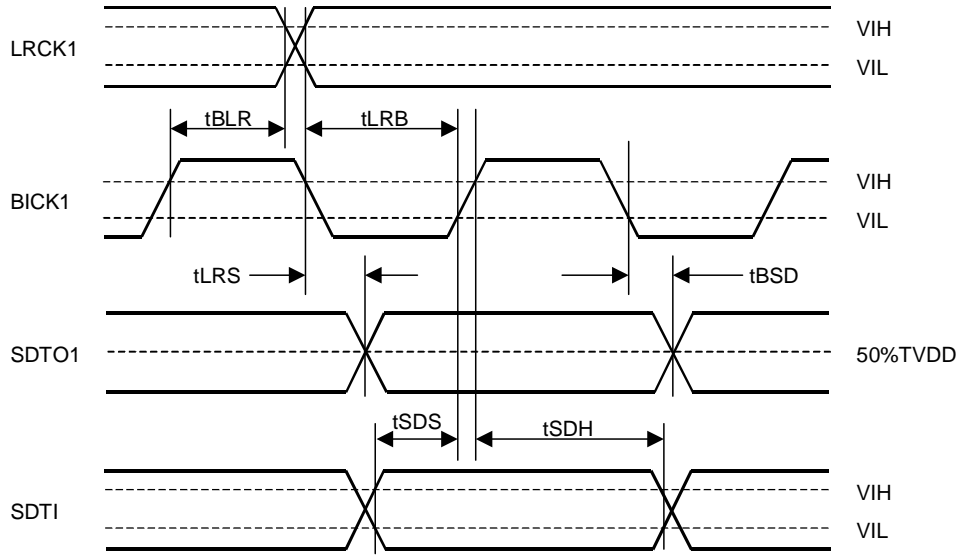

Audio Interface Timing (Normal mode)

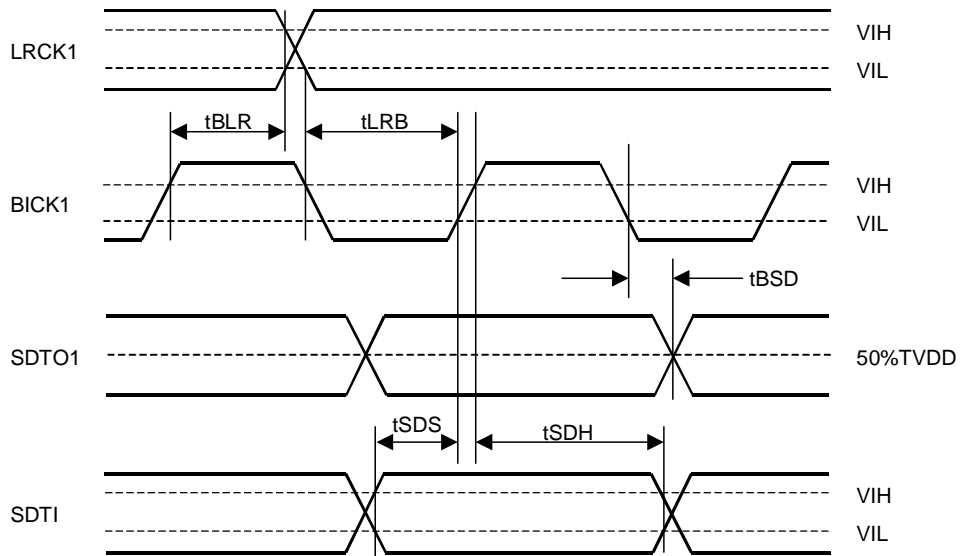

Audio Interface Timing (TDM 256 mode, TDM 128 mode)

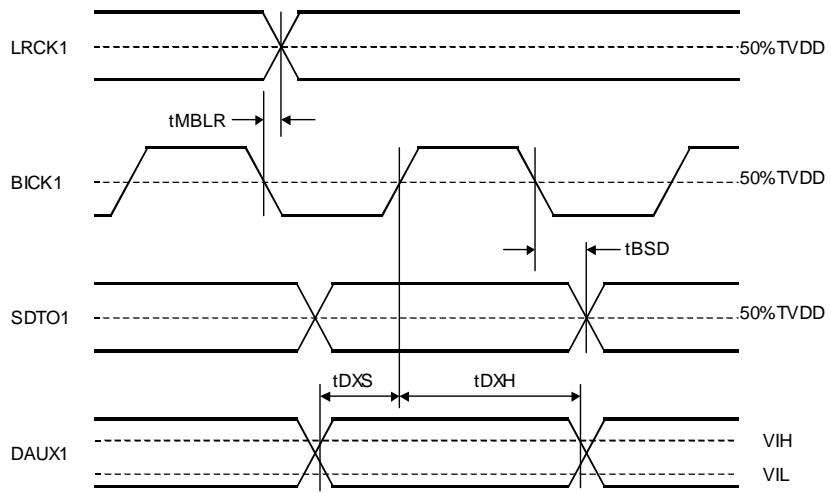

Audio Interface timing (Master Mode)

<b>SWITCHING CHARACTERISTICS (DIR/DIT part)</b>
---

(Ta=25°C; DVDD, AVDD, PVDD4.75~5.25V, TVDD=2.7~5.25V; C<sub>L</sub>=20pF)

Parameter		Symbol	min	typ	max	Units
<b>Master Clock Timing</b>						
Crystal Resonator	Frequency	fXTAL	11.2896		24.576	MHz
External Clock	Frequency	fECLK	11.2896		24.576	MHz
	Duty	dECLK	40	50	60	%
MCKO1 Output	Frequency	fMCK1	4.096		24.576	MHz
	Duty	dMCK1	40	50	60	%
MCKO2 Output	Frequency	fMCK2	2.048		24.576	MHz
	Duty	dMCK2	40	50	60	%
PLL Clock Recover Frequency (RX0-7)		fpll	32	-	192	kHz
LRCK2 Frequency		fs	32		192	kHz
Duty Cycle		dLCK	45		55	%
<b>Audio Interface Timing</b>						
<b>Slave Mode</b>						
BICK2 Period		tBCK	80			ns
BICK2 Pulse Width Low		tBCKL	30			ns
Pulse Width High		tBCKH	30			ns
LRCK2 Edge to BICK2 “↑”	(Note 22)	tLRB	20			ns
BICK2 “↑” to LRCK2 Edge	(Note 22)	tBLR	20			ns
LRCK2 to SDTO2 (MSB)		tLRM			30	ns
BICK2 “↓” to SDTO2		tBSD			30	ns
DAUX2 Hold Time		tDXH	20			ns
DAUX2 Setup Time		tDXS	20			ns
<b>Master Mode</b>						
BICK2 Frequency		fBCK		64fs		Hz
BICK2 Duty		dBCK		50		%
BICK2 “↓” to LRCK2		tMBLR	-20		20	ns
BICK2 “↓” to SDTO2		tBSD			15	ns
DAUX2 Hold Time		tDXH	20			ns
DAUX2 Setup Time		tDXS	20			ns

Notes;

22. BICK2 rising edge must not occur at the same time as LRCK2 edge.

■ Timing Diagram(DIR/DIT part)

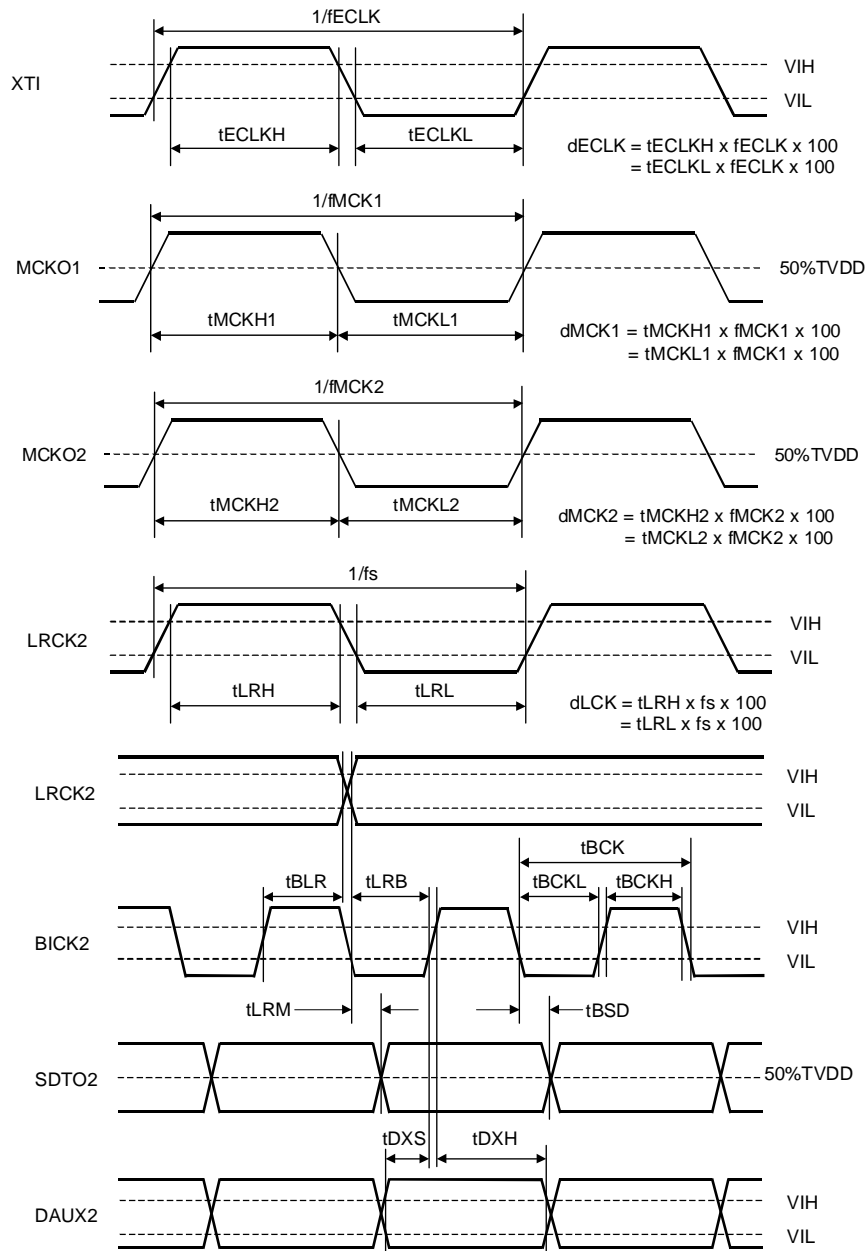

Serial Interface Timing (Slave Mode)

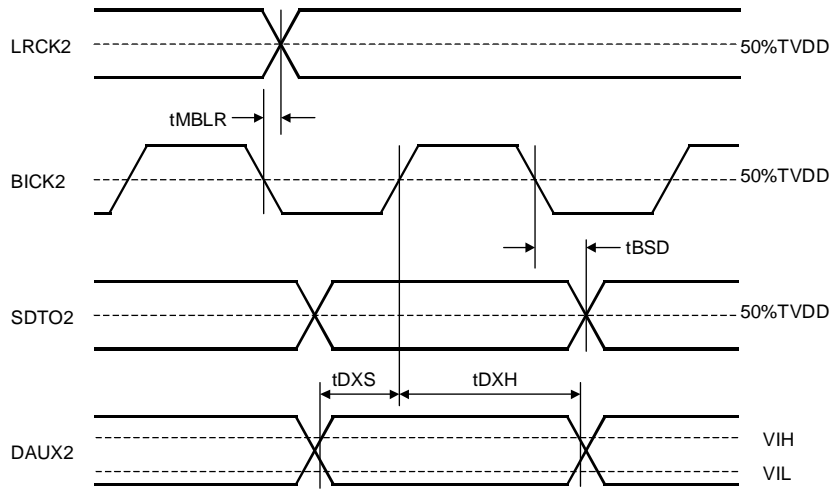

Serial Interface Timing (Master Mode)

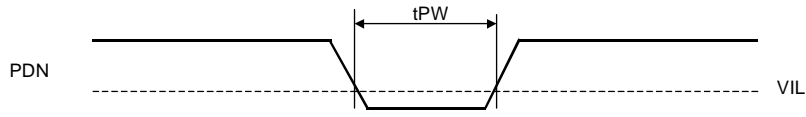

Power Down & Reset Timing

<b>SWITCHING CHARACTERISTICS (ADC/DAC part and DIR/DIT part)</b>
--

(Ta=25°C; AVDD, DVDD, PVDD=4.75~5.25V; TVDD=2.7~5.25V; CL=20pF)

Parameter	Symbol	min	typ	max	Units
<b>Control Interface Timing (4-wire serial mode)</b>					
CCLK Period	tCCK	200			ns
CCLK Pulse Width Low	tCCKL	80			ns
Pulse Width High	tCCKH	80			ns
CDTI Setup Time	tCDS	50			ns
CDTI Hold Time	tCDH	50			ns
CSN "H" Time	tCSW	150			ns
CSN "↓" to CCLK "↑"	tCSS	50			ns
CCLK "↑" to CSN "↑"	tCSH	50			ns
CDTO Delay	tDCD			45	ns
CSN "↑" to CDTO Hi-Z	tCCZ			70	ns
<b>Control Interface Timing (I<sup>2</sup>C Bus mode)</b>					
SCL Clock Frequency	fSCL	-		100	kHz
Bus Free Time Between Transmissions	tBUF	4.7		-	μs
Start Condition Hold Time (prior to first clock pulse)	tHD:STA	4.0		-	μs
Clock Low Time	tLOW	4.7		-	μs
Clock High Time	tHIGH	4.0		-	μs
Setup Time for Repeated Start Condition	tSU:STA	4.7		-	μs
SDA Hold Time from SCL Falling (Note 23)	tHD:DAT	0		-	μs
SDA Setup Time from SCL Rising	tSU:DAT	0.25		-	μs
Rise Time of Both SDA and SCL Lines	tR	-		1.0	μs
Fall Time of Both SDA and SCL Lines	tF	-		0.3	μs
Setup Time for Stop Condition	tSU:STO	4.0		-	μs
Pulse Width of Spike Noise Suppressed by Input Filter	tSP	0		50	ns
Capacitive load on bus	Cb	-		400	pF

## Notes:

23. Data must be held for sufficient time to bridge the 300 ns transition time of SCL.  
 24. I<sup>2</sup>C is a registered trademark of Philips Semiconductors.

Purchase of Asahi Kasei Microsystems Co., Ltd I <sup>2</sup> C components conveys a license under the Philips I <sup>2</sup> C patent to use the components in the I <sup>2</sup> C system, provided the system conform to the I <sup>2</sup> C specifications defined by Philips.
--

■ Timing Diagram (ADC/DAC part and DIR/DIT part)

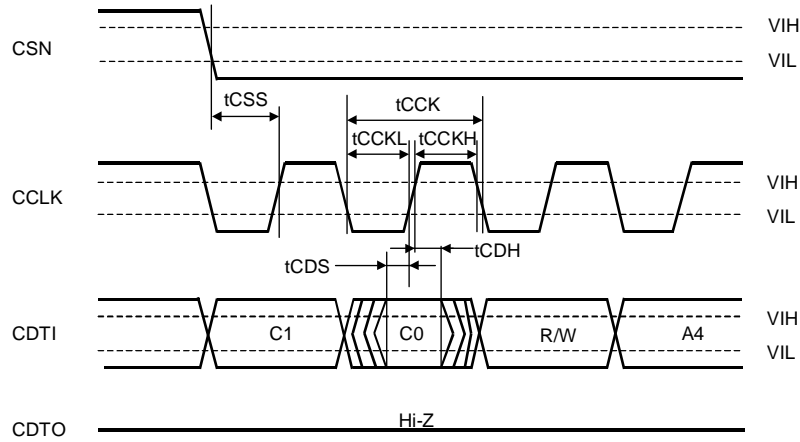

WRITE/READ Command Input Timing in 4-wire serial mode  
The ADC/DAC part doesn't support READ command.

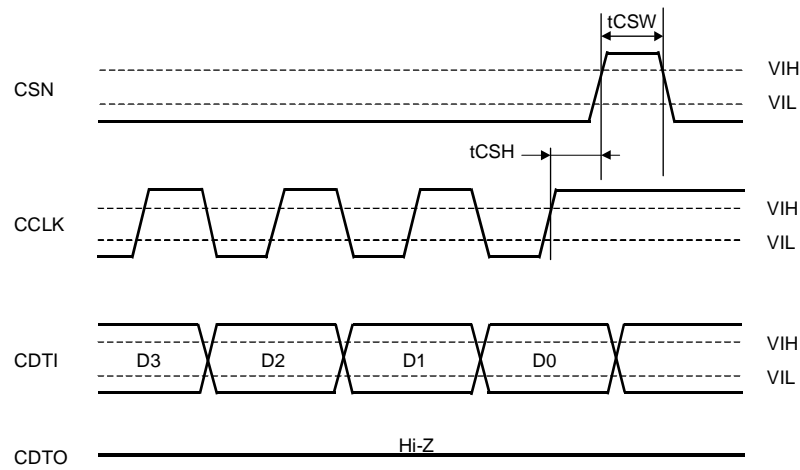

WRITE Data Input Timing in 4-wire serial mode

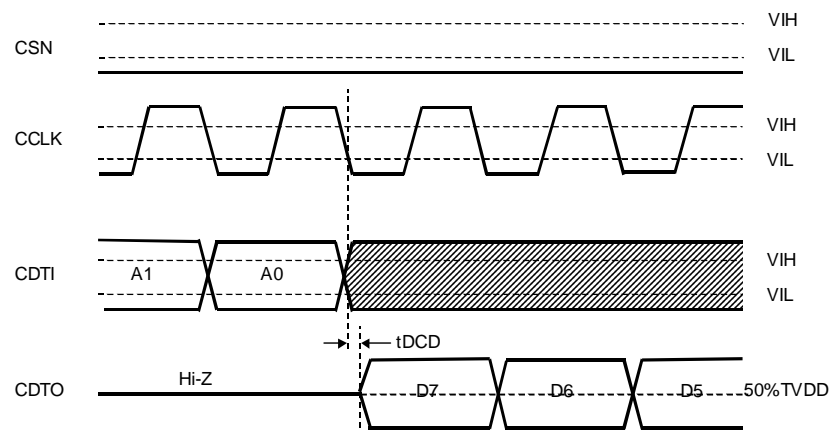

READ Data Output Timing 1 in 4-wire serial mode  
The ADC/DAC part doesn't support READ command..

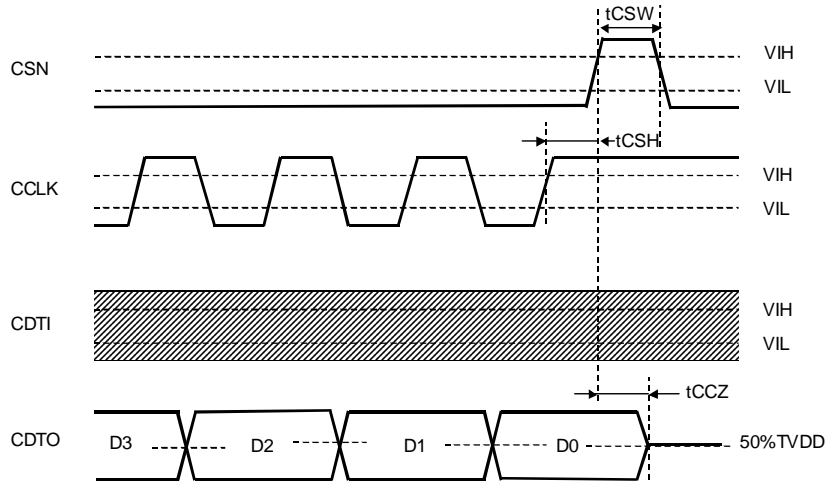

READ Data Input Timing 2 in 4-wire serial mode  
The ADC/DAC part doesn't support READ command.

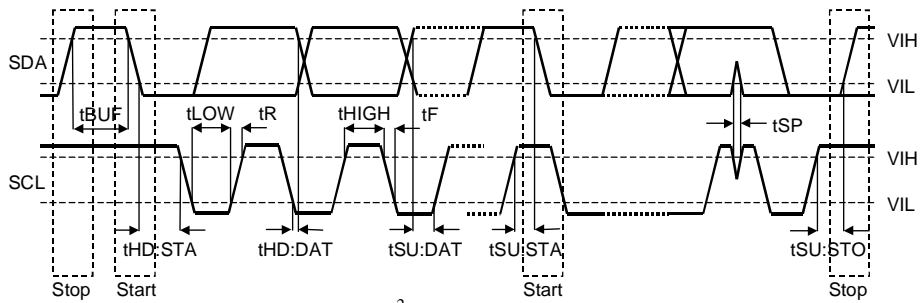

I<sup>2</sup>C Bus mode Timing  
The ADC/DAC part doesn't support READ command.

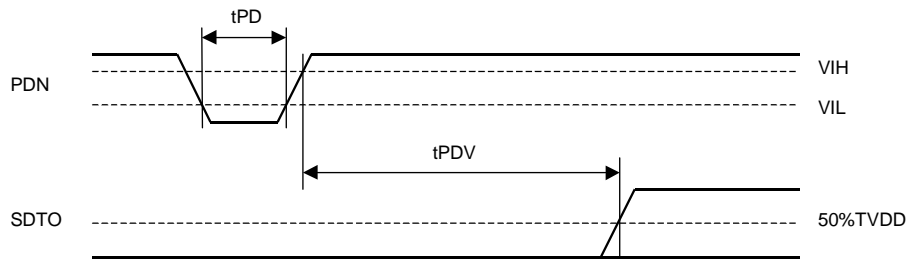

Power-down & Reset Timing



<b>OPERATION OVERVIEW (ADC/DAC part)</b>
--

### ■System Clock

The external clocks, which are required to operate the AK4589, are MCLK, LRCK1 and BICK1. MCLK should be synchronized with LRCK1 but the phase is not critical. There are two methods to set MCLK frequency. In Manual Setting Mode (ACKS bit = "0": Default), the sampling speed is set by DFS1-0 bit (Table 1). The frequency of MCLK at each sampling speed is set automatically. (Table 3, 4, 5) In Auto Setting Mode (ACKS bit = "1"), as MCLK frequency is detected automatically (Table 6) and the internal master clock becomes the appropriate frequency (Table 7), it is not necessary to set DFS1-0 bits.

Only MCLK is necessary in the master mode. Master Clock Input Frequency should be selected by CKS1-0 bits (Table 2), and Sampling Speed should be selected by DFS1-0 bits (Table 1). The frequencies and the duties of the clocks (LRCK1, BICK1) may not be stable after setting CKS1-0 bits and DFS1-0 bits up.

In slave mode, external clocks (MCLK, BICK1, LRCK1) should always be present whenever the AK4589 is in normal operation mode (PDN pin = "H"). If these clocks are not provided, the AK4589 may draw excess current because the device utilizes dynamic refreshed logic internally. If the external clocks are not present, the AK4589 should be in the power-down mode (PDN pin = "L") or in the reset mode (RSTN1 bit = "0"). After exiting reset at power-up etc., the AK4589 is in the power-down mode until MCLK and LRCK are input.

In the Master mode, External clock(MCLK) should always be supplied except in the power-down mode. It is in power-down mode until MCLK will be supplied, when Reset was canceled by Power-ON and so on.

DFS1	DFS0	Sampling Speed (fs)		Default
0	0	Normal Speed Mode	32kHz~48kHz	
0	1	Double Speed Mode	64kHz~96kHz	
1	0	Quad Speed Mode	120kHz~192kHz	

Table 1. Sampling Speed (Manual Setting Mode)

CKS1	CKS0	Normal	Double	Quad	Default
0	0	256fs	128fs	128fs	
0	1	384fs	192fs	128fs	
1	0	512fs	256fs	128fs	
1	1	256fs	256fs	128fs	

Table 2. Master clock input select (Master Mode)

LRCK1	MCLK (MHz)			BICK1 (MHz)
	Fs	256fs	384fs	
32.0kHz	8.1920	12.2880	16.3840	2.0480
44.1kHz	11.2896	16.9344	22.5792	2.8224
48.0kHz	12.2880	18.4320	24.5760	3.0720

Table 3. System Clock Example (Normal Speed Mode @Manual Setting Mode)

LRCK1	MCLK (MHz)			BICK1 (MHz)
	Fs	128fs	192fs	
88.2kHz	11.2896	16.9344	22.5792	5.6448
96.0kHz	12.2880	18.4320	24.5760	6.1440

Table 4. System Clock Example (Double Speed Mode @Manual Setting Mode)

(Note: At Double speed mode (DFS1 = "0", DFS0 = "1"), 128fs and 192fs are not available for ADC.)

LRCK1	MCLK (MHz)			BICK1 (MHz)
	Fs	128fs	192fs	
176.4kHz	22.5792	-	-	11.2896
192.0kHz	24.5760	-	-	12.2880

Table 5. System Clock Example (Quad Speed Mode @Manual Setting Mode)  
(Note: At Quad speed mode (DFS1=“1”, DFS0 = “0”) are not available for ADC.)

MCLK	Sampling Speed
512fs	Normal
256fs	Double
128fs	Quad

Table 6. Sampling Speed (Auto Setting Mode)

LRCK1	MCLK (MHz)			Sampling Speed
	fs	128fs	256fs	
32.0kHz	-	-	16.3840	Normal
44.1kHz	-	-	22.5792	
48.0kHz	-	-	24.5760	
88.2kHz	-	22.5792	-	Double
96.0kHz	-	24.5760	-	
176.4kHz	22.5792	-	-	Quad
192.0kHz	24.5760	-	-	

Table 7. System Clock Example (Auto Setting Mode)

### ■ De-emphasis Filter

The AK4589 includes the digital de-emphasis filter ( $t_c=50/15\mu s$ ) by IIR filter. De-emphasis filter is not available in Double Speed Mode and Quad Speed Mode. This filter corresponds to three sampling frequencies (32kHz, 44.1kHz, 48kHz). De-emphasis of each DAC can be set individually by register data of DEMA1-C0 bits (DAC1: DEMA1-0 bits, DAC2: DEMB1-0 bits, DAC3: DEMC1-0 bits, DAC4: DEMD1-0 bits, see “Register Definitions”).

Mode	Sampling Speed	DEM1	DEM0	DEM	Default
0	Normal Speed	0	0	44.1kHz	
1	Normal Speed	0	1	OFF	
2	Normal Speed	1	0	48kHz	
3	Normal Speed	1	1	32kHz	

Table 8. De-emphasis control

### ■ Digital High Pass Filter

The ADC has a digital high pass filter for DC offset cancel. The cut-off frequency of the HPF is 1.0Hz at  $f_s=48kHz$  and scales with sampling rate (fs).

### ■ Master mode and Slave mode

Master Mode can be selected by setting MASTER pin to “H”. LRCK1 and BICK1 will be outputs in Master Mode. And, Slave Mode can be selected by setting this pin to “L”. LRCK1 and BICK1 will be inputs in Slave Mode. Operation of LRCK1 and BICK1 is shown below Table 9.

PDN pin	PWADN bit, PWDAN bit	MASTER pin	LRCK1 pin	BICK1 pin
L	--	L	Input	Input
		H	“L” output	“L” output
H	“00”	L	Input	Input
		H	“L” output	“L” output
H	Except for “00”	L	Input	Input
		H	Output	Output

Table 9. Operation of LRCK1 and BICK1

### ■ Audio Serial Interface Format

When TDM1-0 bit = “00”, 8 modes can be selected by the DIF1-0 bits as shown in Table 10. In all modes the serial data is MSB-first, 2’s complement format. The SDTO1 is clocked out on the falling edge of BICK1 and the SDTI/DAUX1 are latched on the rising edge of BICK1. Figures 1~4 shows the timing at SDOS bit = “0”. In this case, the SDTO1 outputs the ADC output data. When SDOS bits = “1”, the data input to DAUX1 is converted to SDTO1’s format and output from SDTO1. Mode 2, 3, 6, 7, 10, 11, 14, 15, 18, 19, 22, 23 in SDTI input formats can be used for 16-20bit data by zeroing the unused LSBs. In Table 10, Mode 2 is default setting. And M J shows MSB justified, L J means LSB justified.

Mode	MASTER	TDM1	TDM0	DIF1	DIF0	SDTO1	SDTI1-4, DAUX1	LRCK1		BICK1	
								I/O	I/O		
0	0	0	0	0	0	24bit, M J	20bit, L J	H/L	I	≥ 48fs	I
1	0	0	0	0	1	24bit, M J	24bit, L J	H/L	I	≥ 48fs	I
2	0	0	0	1	0	24bit, M J	24bit, M J	H/L	I	≥ 48fs	I
3	0	0	0	1	1	24bit, I <sup>2</sup> S	24bit, I <sup>2</sup> S	L/H	I	≥ 48fs	I
4	1	0	0	0	0	24bit, M J	20bit, L J	H/L	O	64fs	O
5	1	0	0	0	1	24bit, M J	24bit, L J	H/L	O	64fs	O
6	1	0	0	1	0	24bit, M J	24bit, M J	H/L	O	64fs	O
7	1	0	0	1	1	24bit, I <sup>2</sup> S	24bit, I <sup>2</sup> S	L/H	O	64fs	O

Table 10. Audio data formats (Normal mode, M J shows MSB justified, L J means LSB justified.)

The audio serial interface format becomes the TDM 256 mode if TDM1-0 bits are set to “01”. In the TDM 256 Mode, the serial data of all DAC (eight channels) is input to the SDTI1 pin. The input data to SDTI2-4 pins is ignored. BICK1 should be fixed to 256fs. “H” time and “L” time of LRCK1 pin should be 1/256fs at least. Eight modes can be selected by the DIF1-0 bits was shown in Table 11. In all modes the serial data is MSB-first, 2’s complement format. The SDTO1 pin is clocked out on the falling edge of BICK1 pin and the SDTI1 pin are latched on the rising edge of BICK1 pin. SDOS bit and LOOP1-0 bits should be set to “0” in the TDM mode. TDM 128 Mode can be set by TDM1-0 bit = “10”. In this Mode, the serial data of DAC (four channels; L1, R1, L2, R2) is input to the SDTI1 pin. Other four data (L3, R3, L4, R4) are input to the SDTI2 pin.

Mode	MASTER	TDM 1	TDM0	DIF1	DIF0	SDTO1	SDTI1	LRCK1		BICK1	
									I/O		I/O
8	0	0	1	0	0	24bit, M J	20bit, L J	↑	I	256fs	I
9	0	0	1	0	1	24bit, M J	24bit, L J	↑	I	256fs	I
10	0	0	1	1	0	24bit, M J	24bit, M J	↑	I	256fs	I
11	0	0	1	1	1	24bit, I <sup>2</sup> S	24bit, I <sup>2</sup> S	↓	I	256fs	I
12	1	0	1	0	0	24bit, M J	20bit, L J	↑	O	256fs	O
13	1	0	1	0	1	24bit, M J	24bit, L J	↑	O	256fs	O
14	1	0	1	1	0	24bit, M J	24bit, M J	↑	O	256fs	O
15	1	0	1	1	1	24bit, I <sup>2</sup> S	24bit, I <sup>2</sup> S	↓	O	256fs	O

Table 11. Audio data formats (TDM 256 mode, M J shows MSB justified, L J means LSB justified.)

Mode	MASTER	TDM 1	TDM0	DIF1	DIF0	SDTO1	SDTI1, SDTI2	LRCK1		BICK1	
									I/O		I/O
16	0	1	1	0	0	24bit, M J	20bit, L J	↑	I	128fs	I
17	0	1	1	0	1	24bit, M J	24bit, L J	↑	I	128fs	I
18	0	1	1	1	0	24bit, M J	24bit, M J	↑	I	128fs	I
19	0	1	1	1	1	24bit, I <sup>2</sup> S	24bit, I <sup>2</sup> S	↓	I	128fs	I
20	1	1	1	0	0	24bit, M J	20bit, L J	↑	O	128fs	O
21	1	1	1	0	1	24bit, M J	24bit, L J	↑	O	128fs	O
22	1	1	1	1	0	24bit, M J	24bit, M J	↑	O	128fs	O
23	1	1	1	1	1	24bit, I <sup>2</sup> S	24bit, I <sup>2</sup> S	↓	O	128fs	O

Table 12. Audio data formats (TDM 128 mode, M J shows MSB justified, L J means LSB justified.)

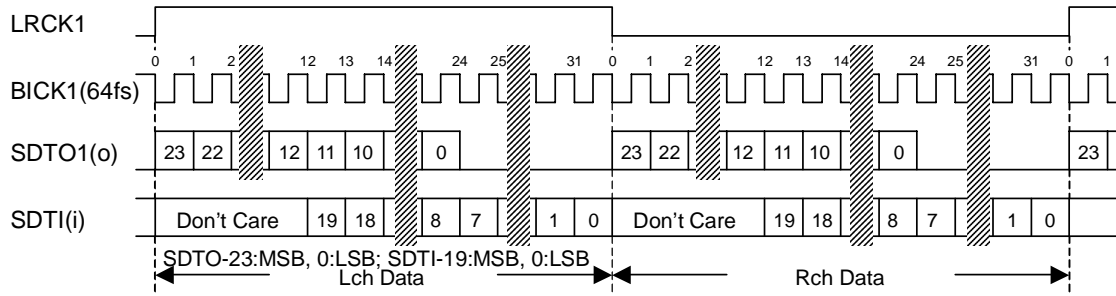

Figure 1. Mode 0,4 Timing

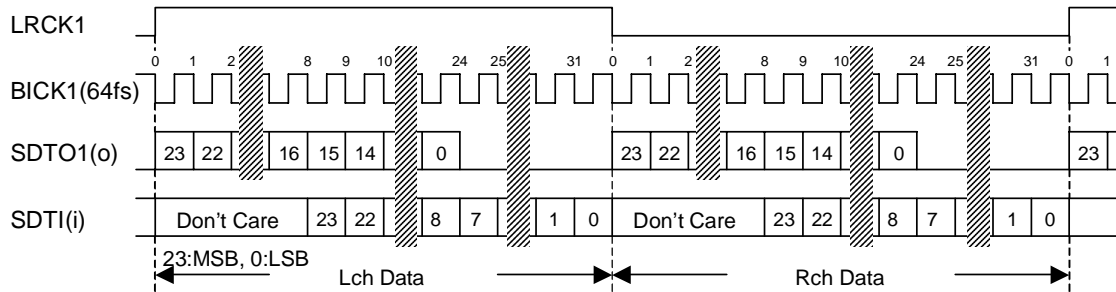

Figure 2. Mode 1,5 Timing

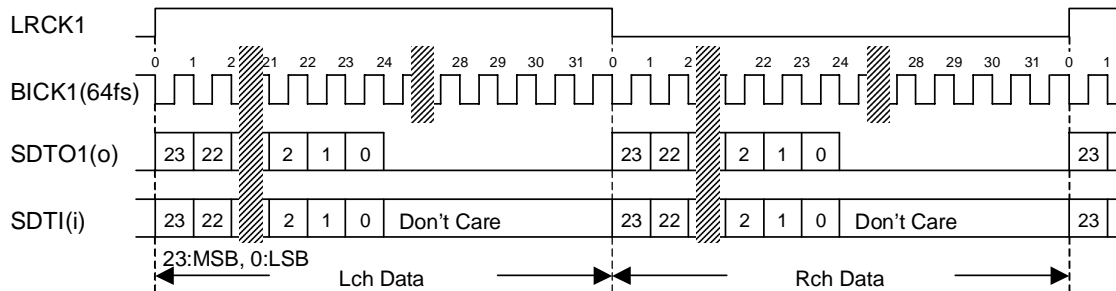

Figure 3. Mode 2,6 Timing

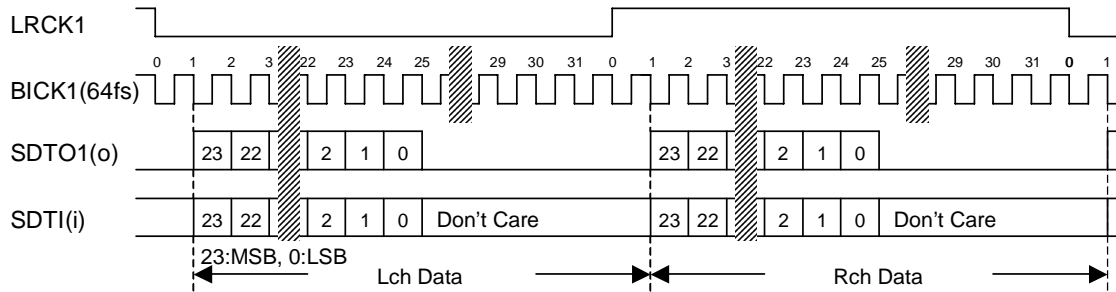

Figure 4. Mode 3,7 Timing

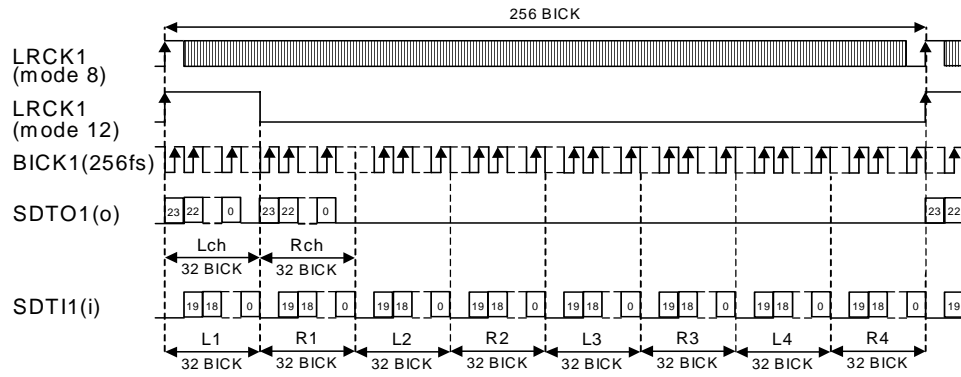

Figure 5. Mode 8 ,12 Timing

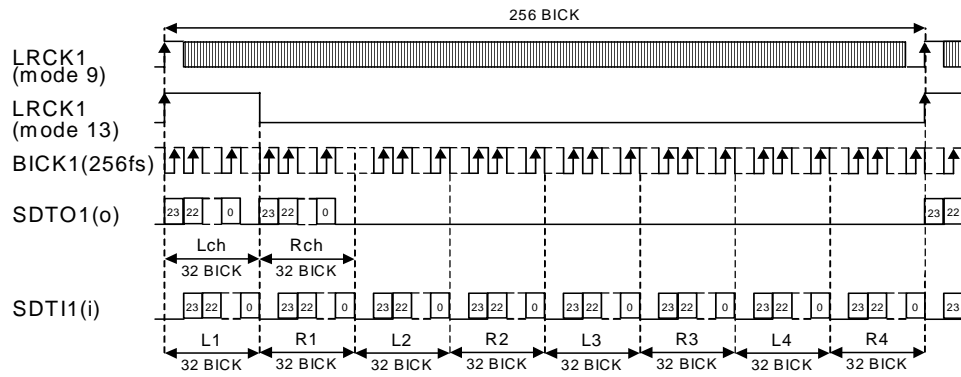

Figure 6. Mode 9 ,13 Timing

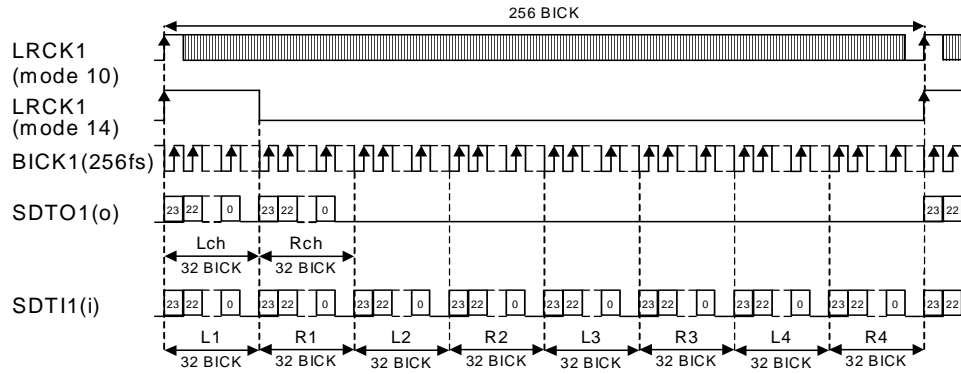

Figure 7. Mode 10 ,14 Timinig

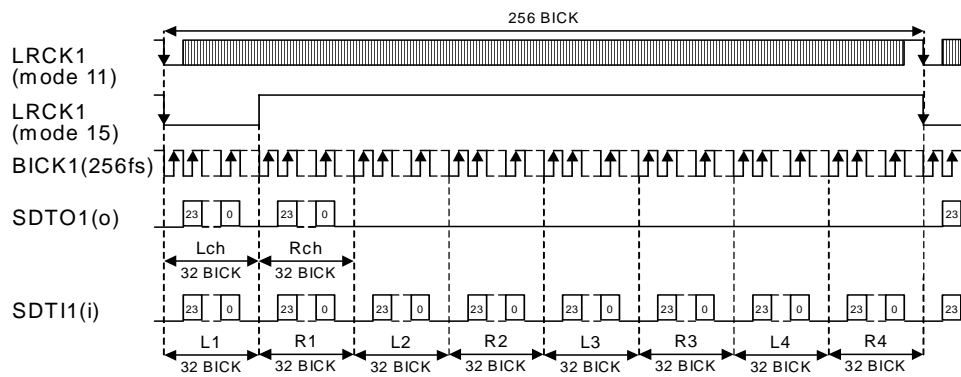

Figure 8. Mode 11 ,15 Timing

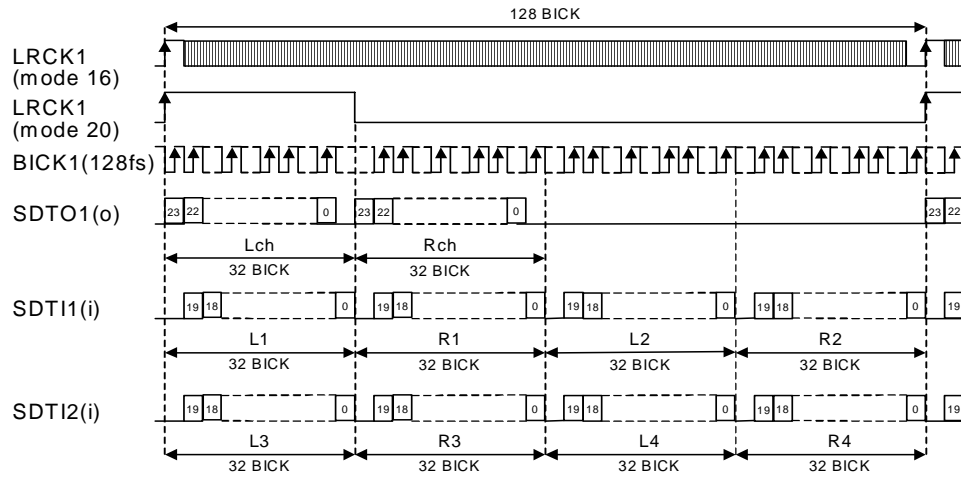

Figure 9. Mode 16 ,20 Timing

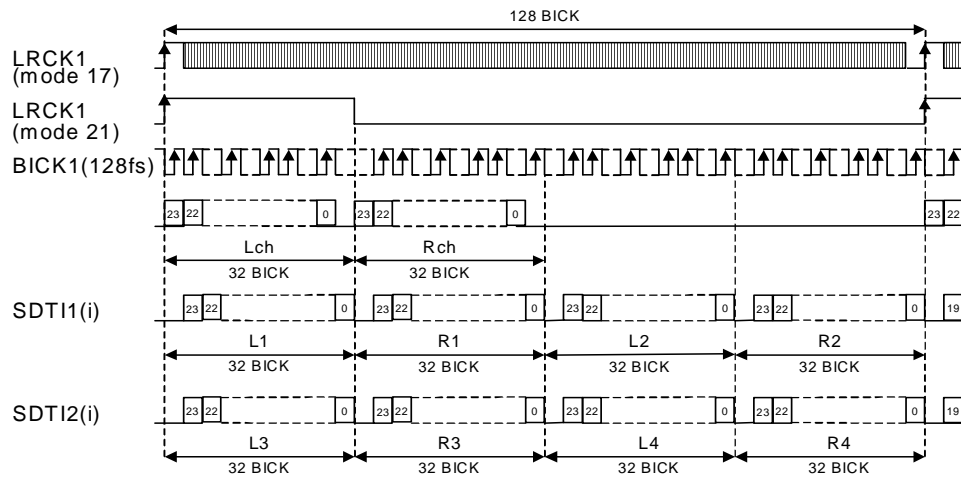

Figure 10. Mode 17 ,21 Timing

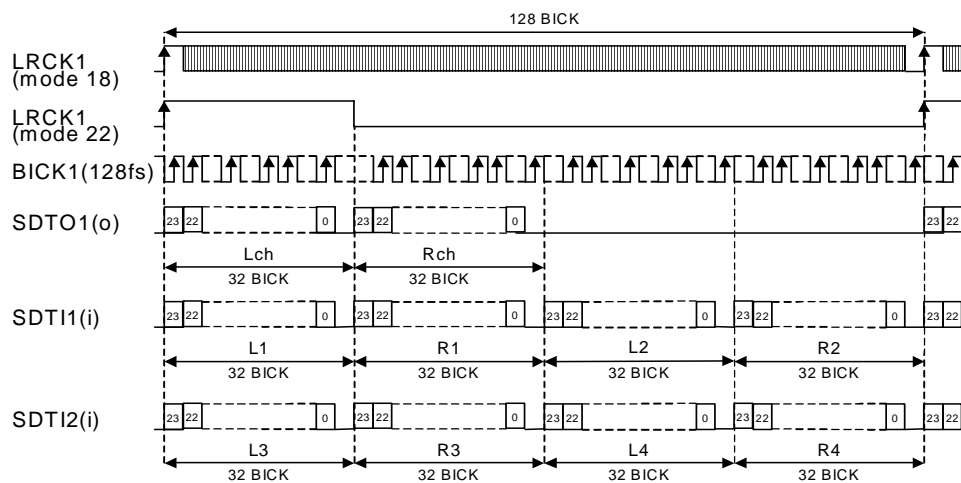

Figure 11. Mode 18 ,22 Timing

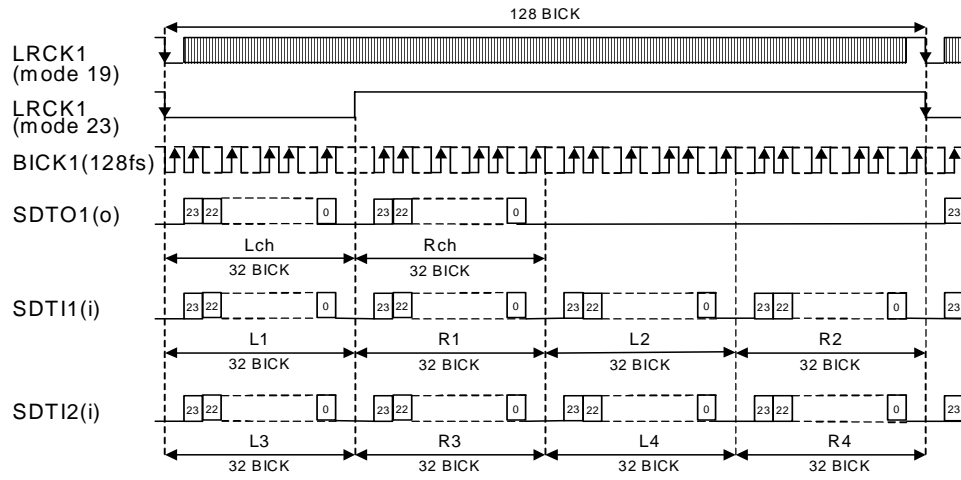

Figure 12. Mode 19 ,23 Timing



■ **Overflow Detection**

The AK4589 has overflow detect function for analog input. Overflow detect function is enable if OVFE bit is set to “1”. OVF pin goes to “H” if analog input of Lch or Rch overflows (more than -0.3dBFS). OVF output for overflowed analog input has the same group delay as ADC ( $GD = 16/fs = 333\mu s$  @ $fs=48kHz$ ). OVF pin is “L” for  $522/fs (=11.8ms$  @ $fs=48kHz$ ) after  $PDN = \uparrow$ , and then overflow detection is enabled.

■ **Zero Detection**

The AK4589 has two pins for zero detect flag outputs. Channel grouping can be selected by DZFM3-0 bits (Table 13). DZF1 pin corresponds to the group 1 channels and DZF2 pin corresponds to the group 2 channels. However DZF2 pin becomes OVF pin if OVFE bit is set to “1”. Zero detection mode is set to mode 0. DZF1 is AND of all eight channels and DZF2 is disabled (“L”) at mode 0. Table 14 shows the relation of OVFE bit and DZF.

When the input data of all channels in the group 1(group 2) are continuously zeros for 8192 LRCK1 cycles, DZF1 (DZF2) pin goes to “H”. DZF1 (DZF2) pin immediately goes to “L” if input data of any channels in the group 1 (group 2) is not zero after going DZF1 (DZF2) “H”.

Mode	DZFM				AOUT								
	3	2	1	0	L1	R1	L2	R2	L3	R3	L4	R4	
0	0	0	0	0	DZF1	DZF1	DZF1	DZF1	DZF1	DZF1	DZF1	DZF1	
1	0	0	0	1	DZF1	DZF1	DZF1	DZF1	DZF1	DZF2	DZF2	DZF2	
2	0	0	1	0	DZF1	DZF1	DZF1	DZF1	DZF2	DZF2	DZF2	DZF2	
3	0	0	1	1	DZF1	DZF1	DZF1	DZF2	DZF2	DZF2	DZF2	DZF2	
4	0	1	0	0	DZF1	DZF1	DZF2	DZF2	DZF2	DZF2	DZF2	DZF2	
5	0	1	0	1	DZF1	DZF2	DZF2	DZF2	DZF2	DZF2	DZF2	DZF2	
6	0	1	1	0	DZF2	DZF2	DZF2	DZF2	DZF2	DZF2	DZF2	DZF2	
7	0	1	1	1	Disable (DZF1=DZF2 = “L”)								Default
8	1	0	0	0	DZF1	DZF1	DZF1	DZF1	DZF1	DZF1	DZF1	DZF2	
9	1	0	0	1	DZF1	DZF1	DZF1	DZF1	DZF1	DZF1	DZF2	DZF2	
10	1	0	1	0	Disable (DZF1=DZF2 = “L”)								
11	1	0	1	1									
12	1	1	0	0									
13	1	1	0	1									
14	1	1	1	0									
15	1	1	1	1									

Table 13. Zero detect control

OVFE bit	DZF1 pin	DZF2/OVF pin
0	Selectable (Table 13)	Selectable (Table 13)
1	Selectable (Table 13)	OVF output

Table 14. DZF1-2 pins outputs

## ■ Digital Attenuator

The AK4589 has channel-independent digital attenuator (128 levels, 0.5dB step). Attenuation level of each channel can be set by each ATT7-0 bits (Table 15).

ATT7-0	Attenuation Level
00H	0dB
01H	-0.5dB
02H	-1.0dB
:	:
7DH	-62.5dB
7EH	-63dB
7FH	MUTE ( $-\infty$ )
:	:
FEH	MUTE ( $-\infty$ )
FFH	MUTE ( $-\infty$ )

Default

Table 15. Attenuation level of digital attenuator

Transition time between set values of ATT7-0 bits can be selected by ATS1-0 bits (Table 16). Transition between set values is the soft transition. Therefore, the switching noise does not occur in the transition.

Mode	ATS1	ATS0	ATT speed
0	0	0	1792/fs
1	0	1	896/fs
2	1	0	256/fs
3	1	1	256/fs

Default

Table 16. Transition time between set values of ATT7-0 bits

The transition between set values is soft transition of 1792 levels in mode 0. It takes 1792/fs (37.3ms@fs=48kHz) from 00H(0dB) to 7FH(MUTE) in mode 0. If PDN pin goes to “L”, the ATTs are initialized to 00H. The ATTs are 00H when RSTN bit = “0”. When RSTN bit return to “1”, the ATTs fade to their current value.

## ■ Soft mute operation

Soft mute operation is performed at digital domain. When the SMUTE bit goes to “1”, the output signal is attenuated by  $-\infty$  during  $ATT\_DATA \times ATT$  transition time (Table 16) from the current ATT level. When the SMUTE bit is returned to “0”, the mute is cancelled and the output attenuation gradually changes to the ATT level during  $ATT\_DATA \times ATT$  transition time. If the soft mute is cancelled before attenuating to  $-\infty$  after starting the operation, the attenuation is discontinued and returned to ATT level by the same cycle. The soft mute is effective for changing the signal source without stopping the signal transmission.

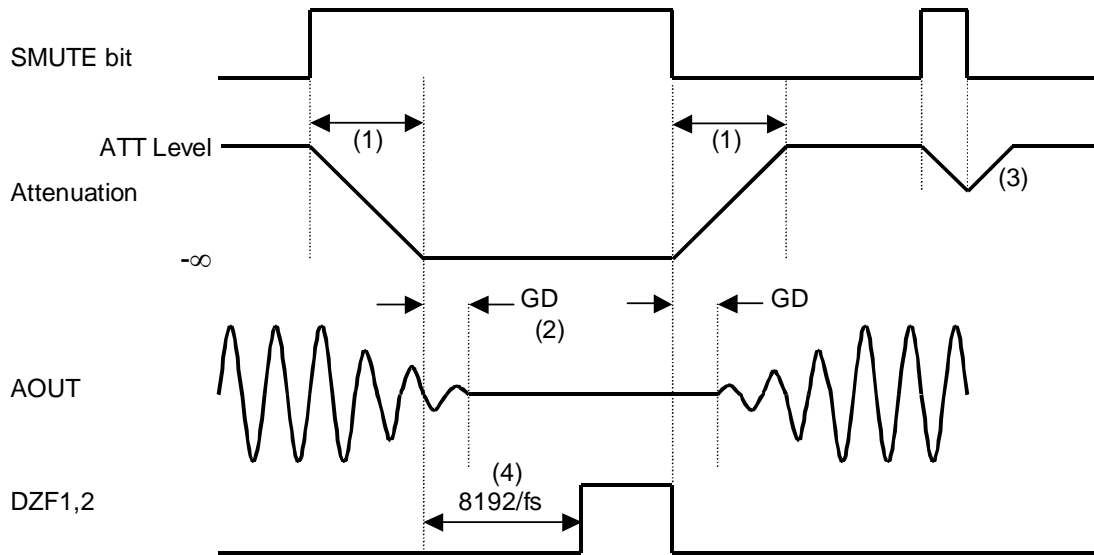

Notes:

- (1)  $ATT\_DATA \times ATT$  transition time (Table 16). For example, in Normal Speed Mode, this time is  $1792LRCK1$  cycles ( $1792/fs$ ) at  $ATT\_DATA=00H$ . ATT transition of the soft-mute is from  $00H$  to  $7FH$
- (2) The analog output corresponding to the digital input has a group delay, GD.
- (3) If the soft mute is cancelled before attenuating to  $-\infty$  after starting the operation, the attenuation is discontinued and returned to ATT level by the same cycle.
- (4) When the input data at all the channels of the group are continuously zeros for  $8192 LRCK1$  cycles, DZF pin of each channel goes to “H”. DZF pin immediately goes to “L” if the input data of either channel of the group are not zero after going DZF “H”.

Figure 13. Soft mute and zero detection

## ■ System Reset

The AK4589 should be reset once by bringing PDN pin = “L” upon power-up. The AK4589 is powered up and the internal timing starts clocking by LRCK1 “↑” after exiting reset and power down state by MCLK. The AK4589 is in the power-down mode until MCLK and LRCK1 are input.

### ■ Power ON/OFF Sequence

The ADC and DACs of AK4589 are placed in the power-down mode by bringing PDN pin “L” and both digital filters are reset at the same time. PDN pin “L” also reset the control registers to their default values. In the power-down mode, the analog outputs go to VCOM voltage and DZF1-2 pins go to “L”. This reset should always be done after power-up. In case of the ADC, an analog initialization cycle starts after exiting the power-down mode. Therefore, the output data, SDTO1 becomes available after 522 cycles of LRCK1 clock. In case of the DAC, an analog initialization cycle starts after exiting the power-down mode. The analog outputs are VCOM voltage during the initialization. Figure 14 shows the sequences of the power-down and the power-up.

The ADC and all DACs can be powered-down individually by PWADN and PWDAN bits. And DAC1-4 can be power-down individually by PD1-4 bits. In this case, the internal register values are not initialized. When PWADN bit = “0”, SDTO1 pin goes to “L”. When PWDAN bit = “0” and PD1-4 bits = “0”, the analog outputs go to VCOM voltage and DZF1-2 pins go to “H”. Because some click noise occurs, the analog output should muted externally if the click noise influences system application.

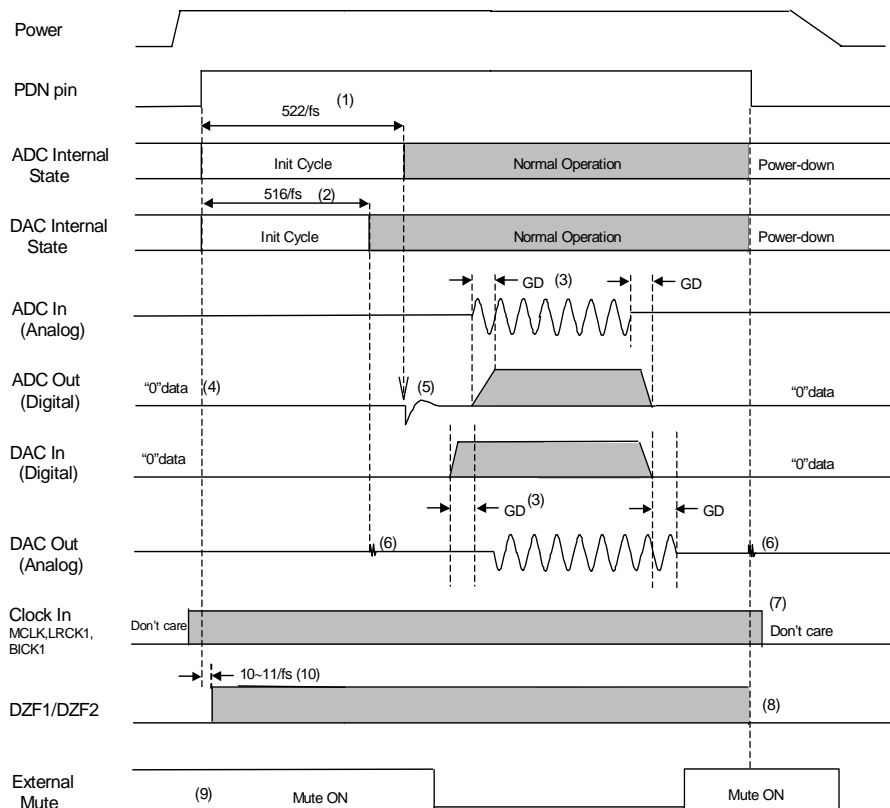

#### Notes:

- (1) The analog part of ADC is initialized after exiting the power-down state.
- (2) The analog part of DAC is initialized after exiting the power-down state.
- (3) Digital output corresponding to analog input and analog output corresponding to digital input have the group delay (GD).
- (4) ADC output is “0” data at the power-down state.
- (5) Click noise occurs at the end of initialization of the analog part. Please mute the digital output externally if the click noise influences system application.
- (6) Click noise occurs at the falling edge of PDN and at 512/fs after the rising edge of PDN.
- (7) When the external clocks (MCLK, BICK1 and LRCK1) are stopped, the AK4589 should be in the power-down mode.
- (8) DZF1-2 pins are “L” in the power-down mode (PDN pin = “L”).
- (9) Please mute the analog output externally if the click noise (6) influences system application.
- (10) DZF= “L” for 10~11/fs after PDN= “↑”.

Figure 14. Power-down/up sequence example

## Reset Function

When RSTN1 bit = "0", ADC and DACs are powered-down but the internal register are not initialized. The analog outputs go to VCOM voltage, DZF1-2 pins go to "H" and SDTO1 pin goes to "L". Because some click noise occurs, the analog output should muted externally if the click noise influences system application. Table 15 shows the power-up sequence.

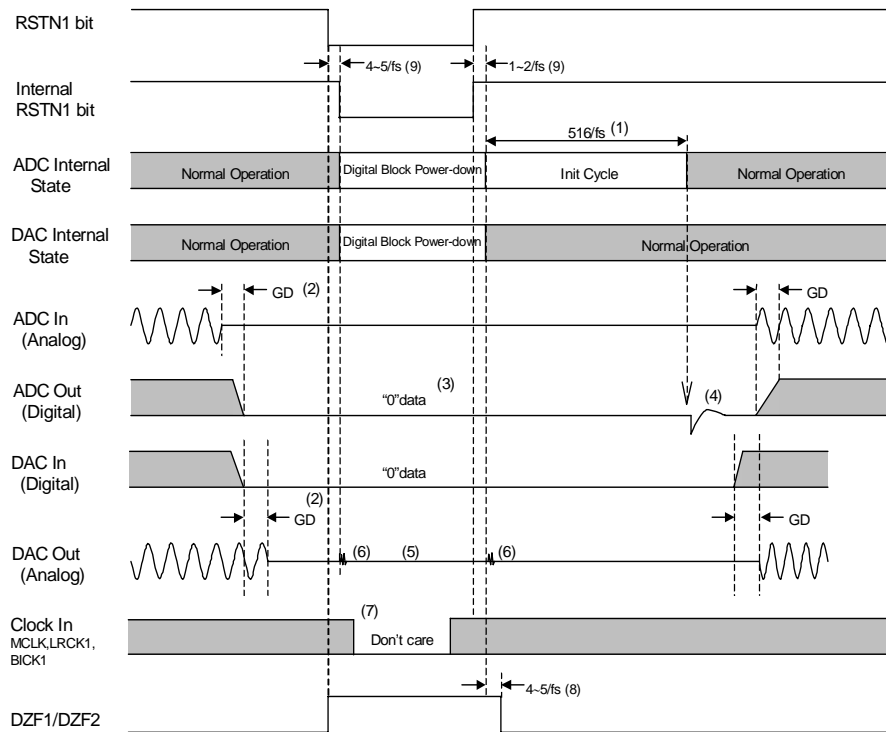

### Notes:

- (1) The analog part of ADC is initialized after exiting the reset state.
- (2) Digital output corresponding to analog input and analog output corresponding to digital input have the group delay (GD).
- (3) ADC output is "0" data at the power-down state.
- (4) Click noise occurs when the internal RSTN bit becomes "1". Please mute the digital output externally if the click noise influences system application.
- (5) When RSTN1 bit = "0", the analog outputs go to VCOM voltage.
- (6) Click noise occurs at  $4\sim 5/f_s$  after RSTN1 bit becomes "0", and occurs at  $1\sim 2/f_s$  after RSTN1 bit becomes "1". This noise is output even if "0" data is input.
- (7) The external clocks (MCLK, BICK1 and LRCK1) can be stopped in the reset mode. When exiting the reset mode, "1" should be written to RSTN1 bit after the external clocks (MCLK, BICK1 and LRCK1) are fed.
- (8) DZF pins go to "H" when the RSTN1 bit becomes "0", and go to "L" at  $6\sim 7/f_s$  after RSTN1 bit becomes "1".
- (9) There is a delay,  $4\sim 5/f_s$  from RSTN1 bit "0" to the internal RSTN bit "0".

Figure 15. Reset sequence example

## ■ DAC partial Power-Down Function

All DACs of The AK4589 can be powered-down individually by PD1-4 bits. The analog part of DAC is in power-down by PD1-4 bits = "1", however, the digital part is not in power-down by it. Even if all DACs were set in power-down by the partial power-down bits, the digital part continue to function. The analog output of the channel which is set in power-down by PD1-4 bits is fixed to the voltage of VCOM. And though DZF detection is being done, the result of DZF detection stops reflecting to DZF1-2 pins. Because some click noise occurs in both set-up and release of power-down, either the analog output should be muted externally or PD1-4 bits should be set up when it is in PWDAN bit = "0" or RSTN bit = "0", if the click noise influences system application. Figure 16 shows the sequence of the power-down and the power-up by PD1-4 bits.

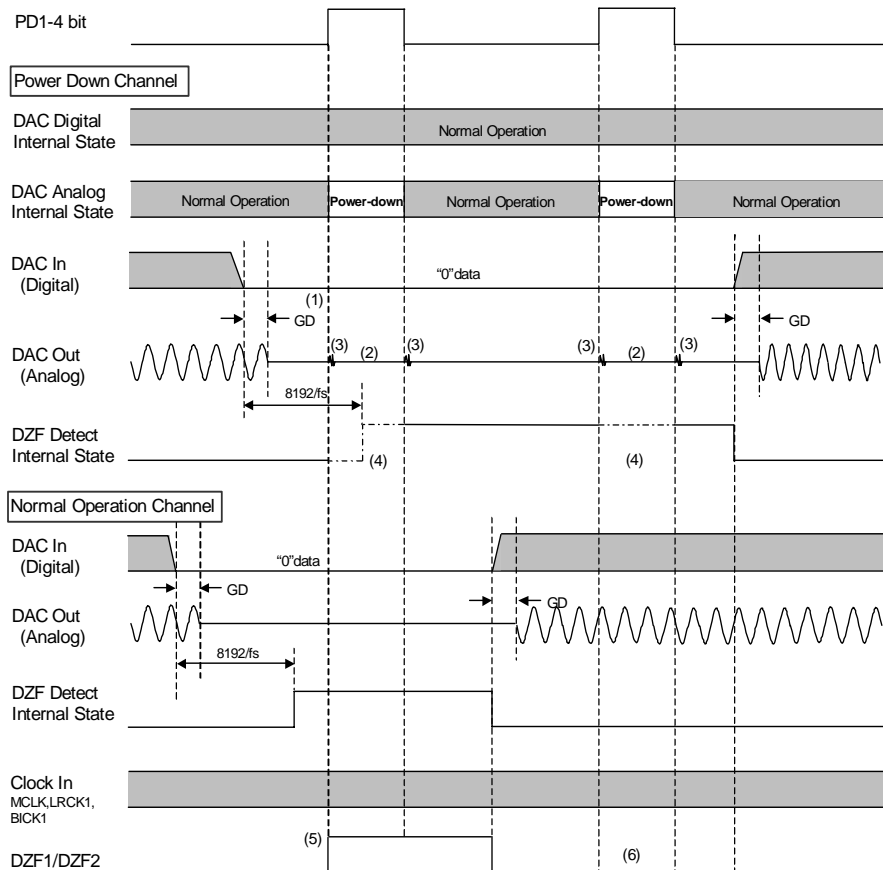

### Notes:

- (1) Digital output corresponding to analog input and analog output corresponding to digital input have the group delay (GD).
- (2) Analog output of the DAC powered down by PD1-4 bits = "1" is fixed to the voltage of VCOM.
- (3) Immediately after PD1-4 bits are changed, some click noise occurs at the output of the channel changed by the own PD bits.
- (4) Though DZF detection is being done at a certain channel which set up PD1-4 bits = "1", the result of DZF detection stops reflecting to DZF1-2 pins.
- (5) DZF detection of the DAC which is set up by the power-down setting is ignored, and DZF1-2 pins become "H".
- (6) When the power-down function is set up and the channel has input signal, even if the partial power-down function is set up, DZF1-2 bits do not become "H".

Figure 16. DAC partial power-down example

## ■ Register Map

Addr	Register Name	D7	D6	D5	D4	D3	D2	D1	D0
00H	Control 1	0	0	TDM1	TDM0	DIF1	DIF0	0	SMUTE
01H	Control 2	CKS1	DFS1	LOOP1	LOOP0	SDOS	DFS0	ACKS	CKS0
02H	LOUT1 Volume Control	ATT7	ATT6	ATT5	ATT4	ATT3	ATT2	ATT1	ATT0
03H	ROUT1 Volume Control	ATT7	ATT6	ATT5	ATT4	ATT3	ATT2	ATT1	ATT0
04H	LOUT2 Volume Control	ATT7	ATT6	ATT5	ATT4	ATT3	ATT2	ATT1	ATT0
05H	ROUT2 Volume Control	ATT7	ATT6	ATT5	ATT4	ATT3	ATT2	ATT1	ATT0
06H	LOUT3 Volume Control	ATT7	ATT6	ATT5	ATT4	ATT3	ATT2	ATT1	ATT0
07H	ROUT3 Volume Control	ATT7	ATT6	ATT5	ATT4	ATT3	ATT2	ATT1	ATT0
08H	De-emphasis	DEMD1	DEMD0	DEMA1	DEMA0	DEMB1	DEMB0	DEMC1	DEMC0
09H	ATT speed & Power Down Control	0	PD4	ATS1	ATS0	PD3	PD2	PD1	RSTN1
0AH	Zero detect	OVFE	DZFM3	DZFM2	DZFM1	DZFM0	PWVRN	PWADN	PWDAN
0BH	LOUT4 Volume Control	ATT7	ATT6	ATT5	ATT4	ATT3	ATT2	ATT1	ATT0
0CH	ROUT4 Volume Control	ATT7	ATT6	ATT5	ATT4	ATT3	ATT2	ATT1	ATT0

Note: For addresses from 0DH to 1FH, data is not written.

When PDN pin goes to “L”, the registers are initialized to their default values.

When RSTN1 bit goes to “0”, the internal timing is reset and DZF1-2 pins go to “H”, but registers are not initialized to their default values.

## ■ Register Definitions

Addr	Register Name	D7	D6	D5	D4	D3	D2	D1	D0
00H	Control 1	0	0	TDM1	TDM0	DIF1	DIF0	0	SMUTE
	Default	0	0	0	0	1	0	0	0

SMUTE: Soft Mute Enable

0: Normal operation

1: All DAC outputs soft-muted

DIF1-0: Audio Data Interface Modes (see Table 10)

Initial: “10”, mode 2

TDM1-0: TDM Format Select (see Table 11, 12)

Mode	TDM1	TDM0	SDTI	Sampling Speed
0	0	0	1-4	Normal, Double, Four Times Speed
1	0	1	1	Normal Speed
2	1	1	1-2	Double Speed

Addr	Register Name	D7	D6	D5	D4	D3	D2	D1	D0
01H	Control 2	CKS1	DFS1	LOOP1	LOOP0	SDOS	DFS0	ACKS	CKS0
	Default	0	0	0	0	0	0	0	0

ACKS: Master Clock Frequency Auto Setting Mode Enable

0: Disable, Manual Setting Mode

1: Enable, Auto Setting Mode

Master clock frequency is detected automatically at ACKS bit "1". In this case, the setting of DFS1-0 bits are ignored. When this bit is "0", DFS1-0 bits set the sampling speed mode.

DFS1-0: Sampling speed mode (see Table 1)

The setting of DFS1-0 bits are ignored at ACKS bit "1".

CKS0-1: Master clock frequency select (see Table 2)

SDOS: SDTO1 source select

0: ADC

1: DAUX

SDOS bit should be set to "0" at TDM bit "1".

In the case of PWADN bit ="0" and PWDAN bit ="0", the setting of SDOS bit becomes invalid. And ADC is selected.

The output of SDTO1 becomes "L" at PWADN bit ="0".

LOOP1-0: Loopback mode enable

00: Normal (No loop back)

01: LIN → LOUT1, LOUT2, LOUT3, LOUT4

RIN → ROUT1, ROUT2, ROUT3, ROUT4

The digital ADC output (DAUX1 input if SDOS = "1") is connected to the digital DAC input. In this mode, the input DAC data to SDTI1-3 is ignored. The audio format of SDTO1 at loopback mode becomes mode 2 at mode 0, and mode 3 at mode 1, respectively.

10: SDTI1(L) → SDTI2(L), SDTI3(L), SDTI4(L)

SDTI1(R) → SDTI2(R), SDTI3(R), SDTI4(R)

In this mode the input DAC data to SDTI2-4 is ignored.

11: N/A

LOOP1-0 bits should be set to "00" at TDM bit "1".

In the case of PWADN bit ="0" and PWDAN bit ="0", the setting of LOOP1-0 bits become invalid. And ADC is selected. And it becomes the normal operation (No loop back).



Addr	Register Name	D7	D6	D5	D4	D3	D2	D1	D0
02H	LOUT1 Volume Control	ATT7	ATT6	ATT5	ATT4	ATT3	ATT2	ATT1	ATT0
03H	ROUT1 Volume Control	ATT7	ATT6	ATT5	ATT4	ATT3	ATT2	ATT1	ATT0
04H	LOUT2 Volume Control	ATT7	ATT6	ATT5	ATT4	ATT3	ATT2	ATT1	ATT0
05H	ROUT2 Volume Control	ATT7	ATT6	ATT5	ATT4	ATT3	ATT2	ATT1	ATT0
06H	LOUT3 Volume Control	ATT7	ATT6	ATT5	ATT4	ATT3	ATT2	ATT1	ATT0
07H	ROUT3 Volume Control	ATT7	ATT6	ATT5	ATT4	ATT3	ATT2	ATT1	ATT0
0BH	LOUT4 Volume Control	ATT7	ATT6	ATT5	ATT4	ATT3	ATT2	ATT1	ATT0
0CH	ROUT4 Volume Control	ATT7	ATT6	ATT5	ATT4	ATT3	ATT2	ATT1	ATT0
Default		0	0	0	0	0	0	0	0

ATT7-0: Attenuation Level (see Table 15)

Addr	Register Name	D7	D6	D5	D4	D3	D2	D1	D0
08H	De-emphasis	DEMD1	DEMD	DEMA	DEMA	DEMB	DEMB	DEMC	DEMC
			0	1	0	1	0	1	0
Default		0	1	0	1	0	1	0	1

DEMA1-0: De-emphasis response control for DAC1 data on SDTI1 (see Table 8)  
Initial: "01", OFF

DEMB1-0: De-emphasis response control for DAC2 data on SDTI2 (see Table 8)  
Initial: "01", OFF

DEMC1-0: De-emphasis response control for DAC3 data on SDTI3 (see Table 8)  
Initial: "01", OFF

DEMD1-0: De-emphasis response control for DAC4 data on SDTI4 (see Table 8)  
Initial: "01", OFF

Addr	Register Name	D7	D6	D5	D4	D3	D2	D1	D0
09H	ATT speed & Power Down Control	0	PD4	ATS1	ATS0	PD3	PD2	PD1	RSTN1
Default		0	0	0	0	0	0	0	1

RSTN1: Internal timing reset

0: Reset. DZF1-2 pins go to "H", but registers are not initialized.

1: Normal operation

ATS1-0: Digital attenuator transition time setting (see Table 16)

Initial: "00", mode 0

PD1-0: Power-down control (0: Power-up, 1: Power-down)

PD1: Power down control of DAC1

PD2: Power down control of DAC2

PD3: Power down control of DAC3

PD4: Power down control of DAC4

Addr	Register Name	D7	D6	D5	D4	D3	D2	D1	D0
0AH	Zero detect	OVFE	DZFM3	DZFM2	DZFM1	DZFM0	PWVRN	PWADN	PWDAN
Default		0	0	1	1	1	1	1	1

PWDAN: Power-down control of DAC1-4

0: Power-down

1: Normal operation

PWADN: Power-down control of ADC

0: Power-down

1: Normal operation

PWVRN: Power-down control of reference voltage

0: Power-down

1: Normal operation

DZFM3-0: Zero detect mode select (see Table 13)

Initial: "0111", disable

OVFE: Overflow detection enable

0: Disable, pin#33 becomes DZF2 pin.

1: Enable, pin#33 becomes OVF pin.

## OPERATION OVERVIEW (DIR/DIT part)

### ■ Non-PCM (AC-3, MPEG, etc.) and DTS-CD Bitstream Detection

The AK4589 has a Non-PCM stream auto-detection function. When the 32bit mode Non-PCM preamble based on Dolby “AC-3 Data Stream in IEC60958 Interface” is detected, the AUTO bit goes “1”. The 96bit sync code consists of 0x0000, 0x0000, 0x0000, 0x0000, 0xF872 and 0x4E1F. Detection of this pattern will set the AUTO bit “1”. Once the AUTO bit is set “1”, it will remain “1” until 4096 frames pass through the chip without additional sync pattern being detected. When those preambles are detected, the burst preambles Pc and Pd that follow those sync codes are stored to registers. The AK4589 also has the DTS-CD bitstream auto-detection function. When The AK4589 detects DTS-CD bitstreams, DTSCD bit goes to “1”. When the next sync code does not come within 4096 flames, DTSCD bit goes to “0” until when AK4589 detects the stream again.

### ■ 192kHz Clock Recovery

On chip low jitter PLL has a wide lock range with 32kHz to 192kHz and the lock time is less than 20ms. The AK4589 has the sampling frequency detect function. By either the clock comparison against X’tal oscillator or using the channel status, AK4589 detects the sampling frequency (32kHz, 44.1kHz, 48kHz, 88.2kHz, 96kHz, 176.4kHz and 192kHz). The PLL loses lock when the received sync interval is incorrect.

### ■ Master Clock

The AK4589 has two clock outputs, MCKO1 and MCKO2. These clocks are derived from either the recovered clock or from the X’tal oscillator. The frequencies of the master clock outputs (MCKO1 and MCKO2) are set by OCKS0 and OCKS1 as shown in Table 17. The 512fs clock will not output when 96kHz and 192kHz. The 256fs clock will not output when 192kHz.

No.	OCKS1	OCKS0	MCKO1	MCKO2	X’tal	fs (max)	
0	0	0	256fs	256fs	256fs	96 kHz	Default
1	0	1	256fs	128fs	256fs	96 kHz	
2	1	0	512fs	256fs	512fs	48 kHz	
3	1	1	128fs	64fs	128fs	192 kHz	

Table 17. Master Clock Frequency Select (Stereo mode)

### ■ Clock Operation Mode

The CM0/CM1 pins (or bits) select the clock source and the data source of SDTO. In Mode 2, the clock source is switched from PLL to X’tal when PLL goes unlock state. In Mode3, the clock source is fixed to X’tal, but PLL is also operating and the recovered data such as C bits can be monitored. For Mode2 and 3, it is recommended that the frequency of X’tal is different from the recovered frequency from PLL.

Mode	CM1	CM0	UNLOCK	PLL	X’tal	Clock source	SDTO	
0	0	0	-	ON	ON(Note)	PLL	RX	Default
1	0	1	-	OFF	ON	X’tal	DAUX	
2	1	0	0	ON	ON	PLL	RX	
			1	ON	ON	X’tal	DAUX	
3	1	1	-	ON	ON	X’tal	DAUX	

ON: Oscillation (Power-up), OFF: STOP (Power-down)

Note : When the X’tal is not used as clock comparison for fs detection (i.e. XTL1,0= “1,1”), the X’tal is off.

Table 18. Clock Operation Mode select

■ Clock Source

The following circuits are available to feed the clock to XTI pin of AK4589.

1) X'tal

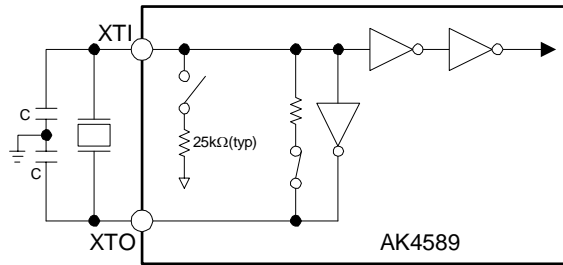

Figure 17. X'tal mode

Note: External capacitance depends on the crystal oscillator (Typ. 10-40pF)

2) External clock

- Note: Input clock must not exceed DVDD.

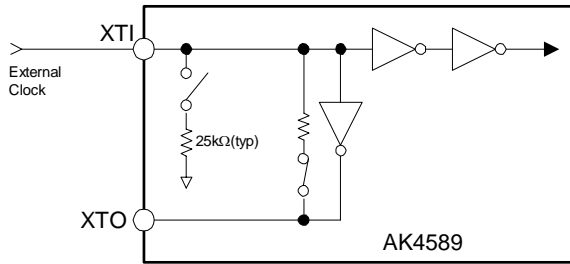

Figure 18 Direct Input  
(Input :CMOS Level)

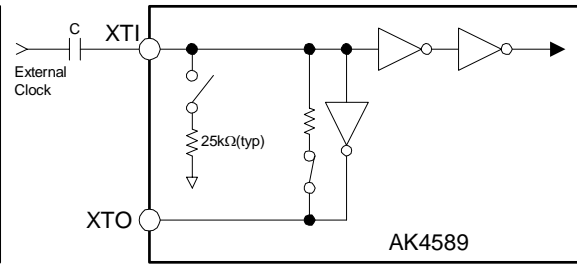

Figure 19 AC Coupling Input  
(Input : ≥40%DVDD, C=0.1μF)

3) Fixed to the Clock Operation Mode 0

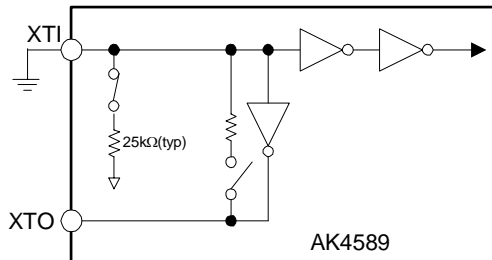

Figure 20. OFF mode

■ Sampling Frequency and Pre-emphasis Detection

The AK4589 has two methods for detecting the sampling frequency as follows.

1. Clock comparison between recovered clock and X'tal oscillator
2. Sampling frequency information on channel status

Those could be selected by XTL1, 0 bits. And the detected frequency is reported on FS3-0 bits.

XTL1	XTL0	X'tal Frequency	Default
0	0	11.2896MHz	
0	1	12.288MHz	
1	0	24.576MHz	
1	1	(Use channel status)	

Table 19. Reference X'tal frequency

Register output				fs	Except XTL1,0= "1,1"	XTL1,0= "1,1"		
					Clock comparison (Note 1)	Consumer mode (Note 2)	Professional mode	
FS3	FS2	FS1	FS0			Byte3 Bit3,2,1,0	Byte0 Bit7,6	Byte4 Bit6,5,4,3
0	0	0	0	44.1kHz	44.1kHz	0 0 0 0	0 1	0 0 0 0
0	0	0	1	Reserved	Reserved	0 0 0 1	(Others)	
0	0	1	0	48kHz	48kHz	0 0 1 0	1 0	0 0 0 0
0	0	1	1	32kHz	32kHz	0 0 1 1	1 1	0 0 0 0
1	0	0	0	88.2kHz	88.2kHz	(1 0 0 0)	0 0	1 0 1 0
1	0	1	0	96kHz	96kHz	(1 0 1 0)	0 0	0 0 1 0
1	1	0	0	176.4kHz	176.4kHz	(1 1 0 0)	0 0	1 0 1 1
1	1	1	0	192kHz	192kHz	(1 1 1 0)	0 0	0 0 1 1

Note1: At least ±3% range is identified as the value in the Table 20. In case of intermediate frequency of those two, FS3-0 bits indicate nearer value. When the frequency is much bigger than 192kHz or much smaller than 32kHz, FS3-0 bits may indicate "0001".

Note2: When consumer mode, Byte3 Bit3-0 are copied to FS3-0 bits.

Table 20. fs Information

The pre-emphasis information is detected and reported on PEM bit. These information are extracted from channel 1 at default. It can be switched to channel 2 by CS12 bit in control register.

PEM	Pre-emphasis	Byte 0 Bits 3-5
0	OFF	≠ 0X100
1	ON	0X100

Table 21. PEM in Consumer Mode

PEM	Pre-emphasis	Byte 0 Bits 2-4
0	OFF	≠ 110
1	ON	110

Table 22. PEM in Professional Mode

## ■ De-emphasis Filter Control

The AK4589 includes the digital de-emphasis filter ( $t_c=50/15\mu s$ ) by IIR filter corresponding to four sampling frequencies (32kHz, 44.1kHz, 48kHz and 96kHz). When DEAU bit="1", the de-emphasis filter is enabled automatically by sampling frequency and pre-emphasis information in the channel status. The AK4589 goes this mode at default. Therefore, in Parallel Mode, the AK4589 is always placed in this mode and the status bits in channel 1 control the de-emphasis filter. In Serial Mode, DEM0/1 and DFS bits can control the de-emphasis filter when DEAU bit is "0". The internal de-emphasis filter is bypassed and the recovered data is output without any change if either pre-emphasis or de-emphasis Mode is OFF.

PEM	FS3	FS2	FS1	FS0	Mode
1	0	0	0	0	44.1kHz
1	0	0	1	0	48kHz
1	0	0	1	1	32kHz
1	1	0	1	0	96kHz
1	(Others)				OFF
0	x	x	x	x	OFF

Table 23. De-emphasis Auto Control at DEAU bit = "1" (Default)

PEM	DFS	DEM1	DEM0	Mode	
1	0	0	0	44.1kHz	Default
1	0	0	1	OFF	
1	0	1	0	48kHz	
1	0	1	1	32kHz	
1	1	0	0	OFF	
1	1	0	1	OFF	
1	1	1	0	96kHz	
1	1	1	1	OFF	
0	x	x	x	OFF	

Table 24. De-emphasis Manual Control at DEAU bit = "0"

## ■ System Reset and Power-Down

The AK4589 has a power-down mode for all circuits by PDN pin can be partially power-down by PWN bit. The RSTN bit initializes the register and resets the internal timing. In Parallel Mode, only the control by PDN pin is enabled. The AK4589 should be reset once by bringing PDN pin = "L" upon power-up.

**PDN Pin:** All analog and digital circuit are placed in the power-down and reset mode by bringing PDN pin = "L". All the registers are initialized, and clocks are stopped. Reading/Writing to the register are disabled.

**RSTN2 Bit (Address 00H; D0):**

All the registers except PWN and RSTN2 bits are initialized by bringing RSTN2 bit = "0". The internal timings are also initialized. Writing to the register is not available except PWN and RSTN2 bits. Reading to the register is disabled.

**PWN Bit (Address 00H; D1):**

The clock recovery part is initialized by bringing PWN bit = "0". In this case, clocks are stopped. The registers are not initialized and the mode settings are kept. Writing and Reading to the registers are enabled.

■ Biphase Input and Through Output

Eight receiver inputs (RX0-7) are available in Serial Control Mode. Each input includes amplifier corresponding to unbalance mode and can accept the signal of 200mV or more. IPS2-0 bits selects the receiver channel. When BCU bit = "1", the Block start signal, C bit and U bit can output from each pins.

IPS2	IPS1	IPS0	INPUT Data
0	0	0	RX0
0	0	1	RX1
0	1	0	RX2
0	1	1	RX3
1	0	0	RX4
1	0	1	RX5
1	1	0	RX6
1	1	1	RX7

Default

Table 25. Recovery Data Select

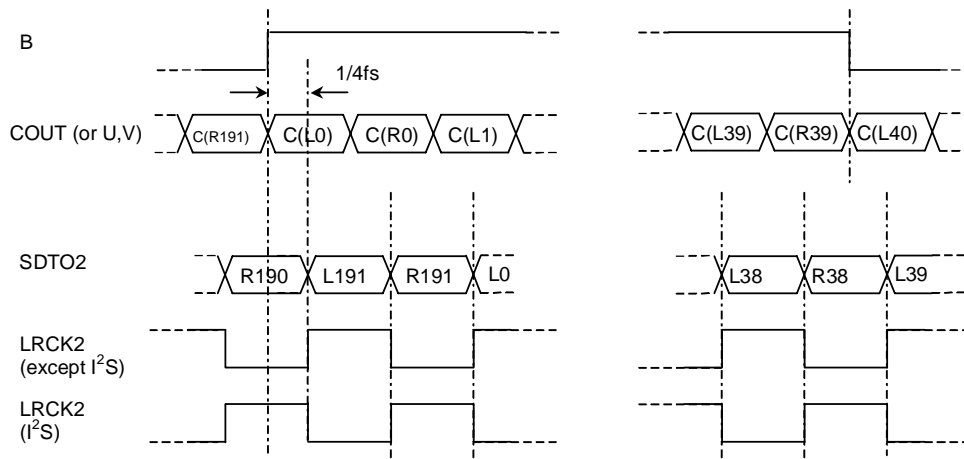

Figure 21. B, C, U, V output/input timings

■ Biphase Output

The AK4589 can output either the through output(from DIR) or transmitter output(DIT; the data from DAUX2 is transformed to IEC60958 format.) from TX1/0 pins. Those could be selected by DIT bit. The source of the through output from TX0 could be selected among RX0-8 by OPS00,01 and 02 bits, for TX1, by OPS10,11 and 12 bits respectively. When output DAUX2 data, V bit could be controlled by VIN pin and first 5 bytes of C bit could be controlled by CT39-CT0 bits in control registers. When bit0= "0"(consumer mode), bit20-23 (Audio channel) could not be controlled directly but be controlled by CT20 bit. When the CT20 bit is "1", AK4589 outputs "1000" as C20-23 for left channel and output "0100" at C20-23 for right channel automatically. When CT20 bit is "0", AK4589 outputs "0000" set as "1000" for sub frame 1, and "0100" for sub frame 2. U bits are fixed to "0".as C20-23 for both channel. U bit could be controlled by UDIT bit as follows; When UDIT bit is "0", U bit is always "0". When UDIT bit is "1", the recovered U bits are used for DIT (DIR/DIT loop mode of U bit). This mode is only available when PLL is locked and the master mode.

OPS02	OPS01	OPS00	Output Data
0	0	0	RX0
0	0	1	RX1
0	1	0	RX2
0	1	1	RX3
1	0	0	RX4
1	0	1	RX5
1	1	0	RX6
1	1	1	RX7

Default

Table 26. Output Data Select for TX0

DIT	OPS12	OPS11	OPS10	Output Data
0	0	0	0	RX0
0	0	0	1	RX1
0	0	1	0	RX2
0	0	1	1	RX3
0	1	0	0	RX4
0	1	0	1	RX5
0	1	1	0	RX6
0	1	1	1	RX7
1	x	x	x	DAUX2

Default

Table 27. Output Data Select for TX1

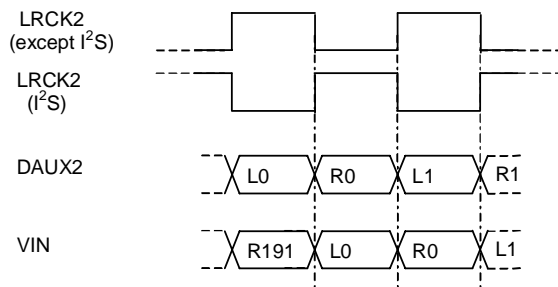

Figure 22. DAUX2 and VIN input timings



■ Biphase signal input/output circuit

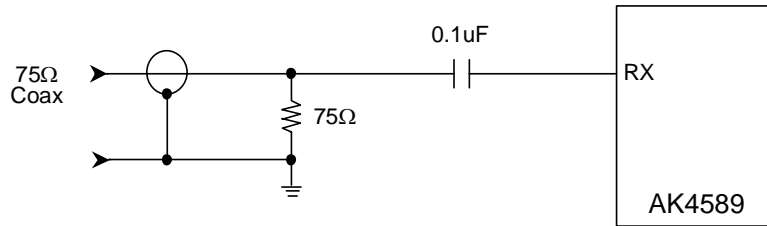

Figure 23. Consumer Input Circuit (Coaxial Input)

Note: In case of coaxial input, if a coupling level to this input from the next RX input line pattern exceeds 50mV, there is a possibility to occur an incorrect operation. In this case, it is possible to lower the coupling level by adding this decoupling capacitor.

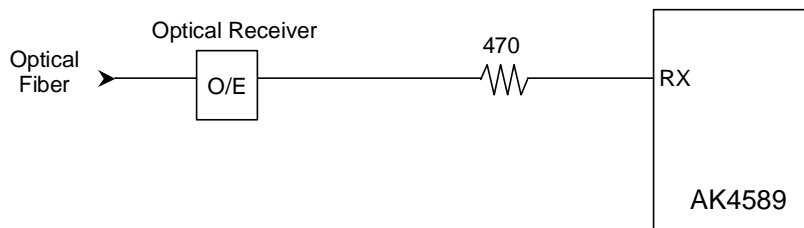

Figure 24. Consumer Input Circuit (Optical Input)

In case of coaxial input, as the input level of RX line is small, in Serial Mode, be careful not to crosstalk among RX input lines. For example, by inserting the shield pattern among them. In Parallel Mode, only one channel input (RX1) is available and RX2-4 change to other pins for audio format control. Those pins must be fixed to “H” or “L”.

The AK4589 includes the TX output buffer. The output level meets combination 0.5V $\pm$ 20% using the external resistor network. The T1 in Figure 25 is a transformer of 1:1.

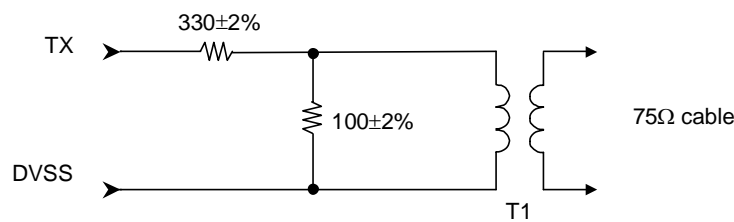

Figure 25. TX External Resistor Network

■ Q-subcode buffers

The AK4589 has Q-subcode buffer for CD application. The AK4589 takes Q-subcode into registers by following conditions.

1. The sync word (S0,S1) is constructed at least 16 “0”s.
2. The start bit is “1”.
3. Those 7bits Q-W follows to the start bit.
4. The distance between two start bits are 8-16 bits.

The QINT bit in the control register goes “1” when the new Q-subcode differs from old one, and goes “0” when QINT bit is read.

	1	2	3	4	5	6	7	8	*
S0	0	0	0	0	0	0	0	0	0...
S1	0	0	0	0	0	0	0	0	0...
S2	1	Q2	R2	S2	T2	U2	V2	W2	0...
S3	1	Q3	R3	S3	T3	U3	V3	W3	0...
:	:	:	:	:	:	:	:	:	:
S97	1	Q97	R97	S97	T97	U97	V97	W97	0...
S0	0	0	0	0	0	0	0	0	0...
S1	0	0	0	0	0	0	0	0	0...
S2	1	Q2	R2	S2	T2	U2	V2	W2	0...
S3	1	Q3	R3	S3	T3	U3	V3	W3	0...
:	:	:	:	:	:	:	:	:	:

↑  
 Q

(\*) number of "0" : min=0; max=8.

Figure 26. Configuration of U-bit(CD)

Q2	Q3	Q4	Q5	Q6	Q7	Q8	Q9	Q10	Q11	Q12	Q13	Q14	Q15	Q16	Q17	Q18	Q19	Q20	Q21	Q22	Q23	Q24	Q25
CTRL				ADRS				TRACK NUMBER								INDEX							
Q26	Q27	Q28	Q29	Q30	Q31	Q32	Q33	Q34	Q35	Q36	Q37	Q38	Q39	Q40	Q41	Q42	Q43	Q44	Q45	Q46	Q47	Q48	Q49
MINUTE						SECOND						FRAME											
Q50	Q51	Q52	Q53	Q54	Q55	Q56	Q57	Q58	Q59	Q60	Q61	Q62	Q63	Q64	Q65	Q66	Q67	Q68	Q69	Q70	Q71	Q72	Q73
ZERO						ABSOLUTE MINUTE						ABSOLUTE SECOND											
Q74	Q75	Q76	Q77	Q78	Q79	Q80	Q81	Q82	Q83	Q84	Q85	Q86	Q87	Q88	Q89	Q90	Q91	Q92	Q93	Q94	Q95	Q96	Q97
ABSOLUTE FRAME								CRC															

$G(x)=x^{16}+x^{12}+x^5+1$

Figure 27. Q-subcode

Addr	Register Name	D7	D6	D5	D4	D3	D2	D1	D0
16H	Q-subcode Address / Control	Q9	Q8	...	...	...	...	Q3	Q2
17H	Q-subcode Track	Q17	Q16	...	...	...	...	Q11	Q10
18H	Q-subcode Index	...	...	...	...	...	...	...	...
19H	Q-subcode Minute	...	...	...	...	...	...	...	...
1AH	Q-subcode Second	...	...	...	...	...	...	...	...
1BH	Q-subcode Frame	...	...	...	...	...	...	...	...
1CH	Q-subcode Zero	...	...	...	...	...	...	...	...
1DH	Q-subcode ABS Minute	...	...	...	...	...	...	...	...
1EH	Q-subcode ABS Second	...	...	...	...	...	...	...	...
1FH	Q-subcode ABS Frame	Q81	Q80	...	...	...	...	Q75	Q74

Figure 28. Q-subcode register

## ■ Error Handling

There are the following eight events that make INT0/1 pins “H”. INT0/1 pins show the status of following conditions.

1. UNLOCK: “1” when the PLL loses lock.  
The AK4589 loses lock when the distance between two preambles is not correct or when those preambles are not correct.
2. PAR: “1” when parity error or biphase coding error is detected, and keeps “1” until this register is read.  
Updated every sub-frame cycle. Reading this register resets itself.
3. AUTO: “1” when Non-PCM bitstream is detected.  
Updated every 4096 frames cycle.
4. DTSCD: “1” when DTS-CD bitstream is detected.  
Updated every DTS-CD sync cycle.
5. AUDION: “1” when the “AUDIO” bit in recovered channel status indicates “1”.  
Updated every block cycle.
6. PEM: “1” when “PEM” in recovered channel status indicates “1”.  
Updated every block cycle.
7. QINT: “1” when Q-subcode differ from old one, and keeps “1” until this register is read.  
Updated every sync code cycle for Q-subcode. Reading this register resets itself.
8. CINT: “1” when received C bits differ from old one, and keeps “1” until this register is read.  
Updated every block cycle. Reading this register resets itself.

Both INT0/1 are fixed to “L” when the PLL is off (CM1,0= “01”). Once the INT0 pin goes to “H”, this pin holds “H” for 1024/fs cycles (this value can be changed by EFH0/1 bits) after those events are removed. INT1 pin goes to “L” at the same time when those events are removed. Each INT0/1 pins can mask those eight events individually. Once PAR, QINT and CINT bit goes to “1”, those registers are held to “1” until those registers are read. While the AK4589 loses lock, registers regarding C-bit or U-bits are not initialized and keep previous value.

INT0/1 pin output the ORed signal among those eight events. However, each events can be masked by each mask bits. When each bit masks those events, the event does not affect INT0/1 pins operation (those mask do not affect those registers (UNLOCK, PAR, etc.) themselves. Once INT0 pin goes “H”, it maintains “H” for 1024/fs cycles (this value can be changed by EFH0-1 bits) after the all events are removed. Once those PAR, QINT or CINT bit goes “1”, it holds “1” until reading those registers. While the AK4589 loses lock, the channel status an Q-subcode bits are not updated and holds the previous data. At initial state, INT0 outputs the ORed signal between UNLOCK and PAR, INT1 outputs the ORed signal among AUTO, DTSCD and AUDION.

Register								Pin		
UNLOCK	PAR	AUTO	DTSCD	AUDION	PEM	QINT	CINT	SDTO2	V	TX
1	x	x	x	x	x	x	x	“L”	“L”	Output
0	1	x	x	x	x	x	x	Previous Data	Output	Output
0	0	1	x	x	x	x	x	Output	Output	Output
0	0	x	1	x	x	x	x	Output	Output	Output
0	0	x	x	1	x	x	x	Output	Output	Output
0	0	x	x	x	1	x	x	Output	Output	Output
0	0	x	x	x	x	1	x	Output	Output	Output
0	0	x	x	x	x	x	1	Output	Output	Output

Table 28. Error Handling

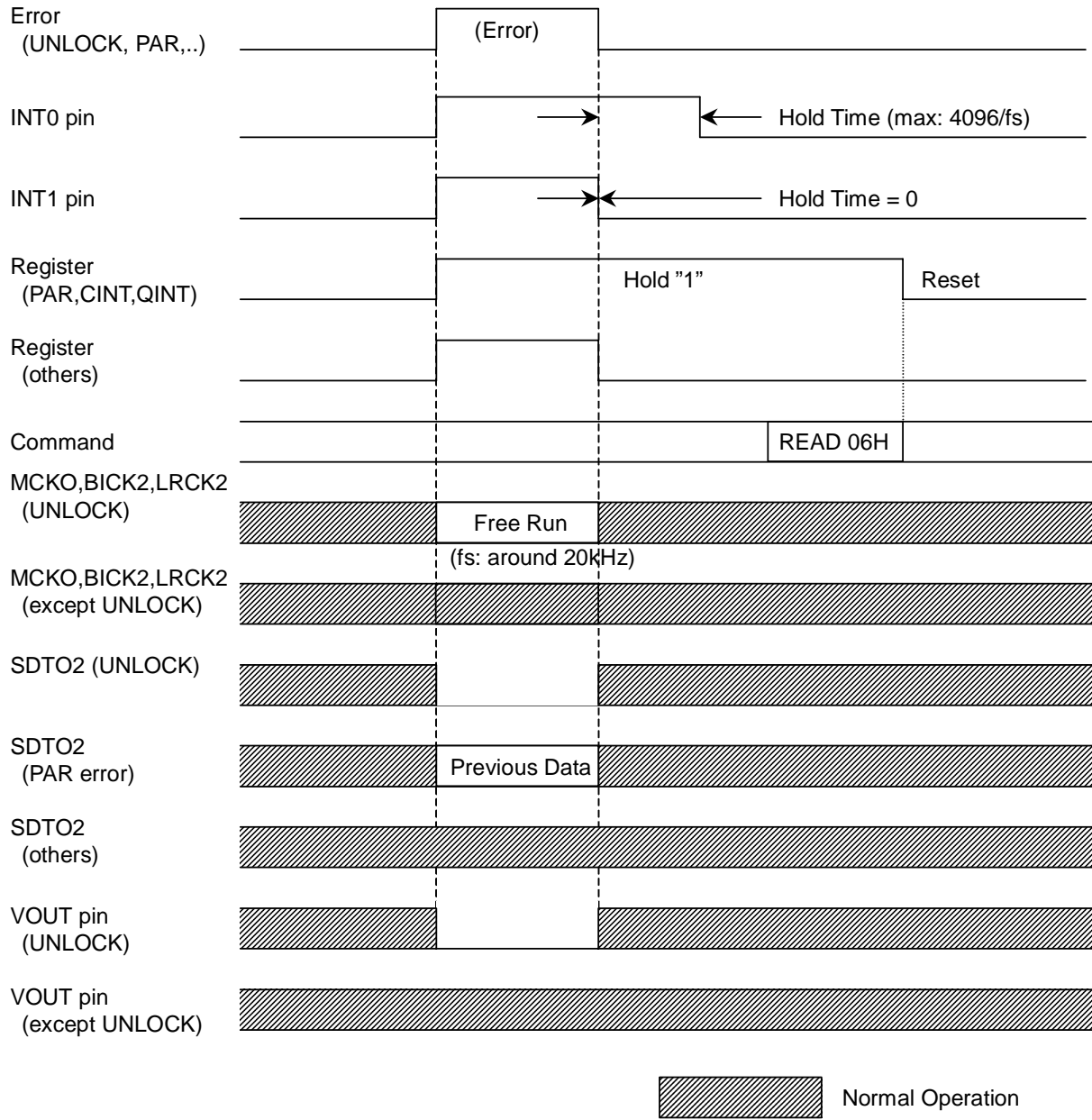

Figure 29. INT0/1 pin timing

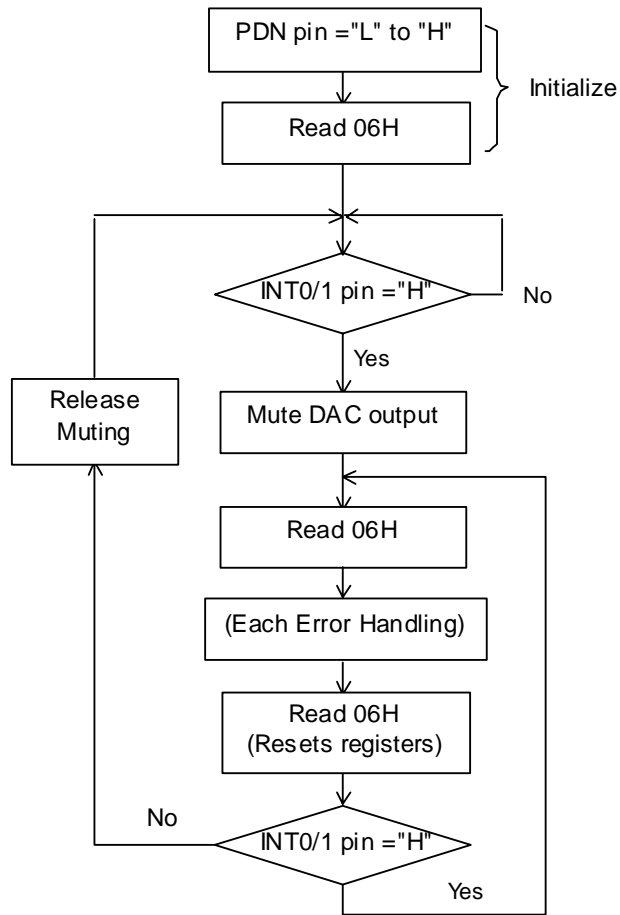

Figure 30. Error Handling Sequence Example 1

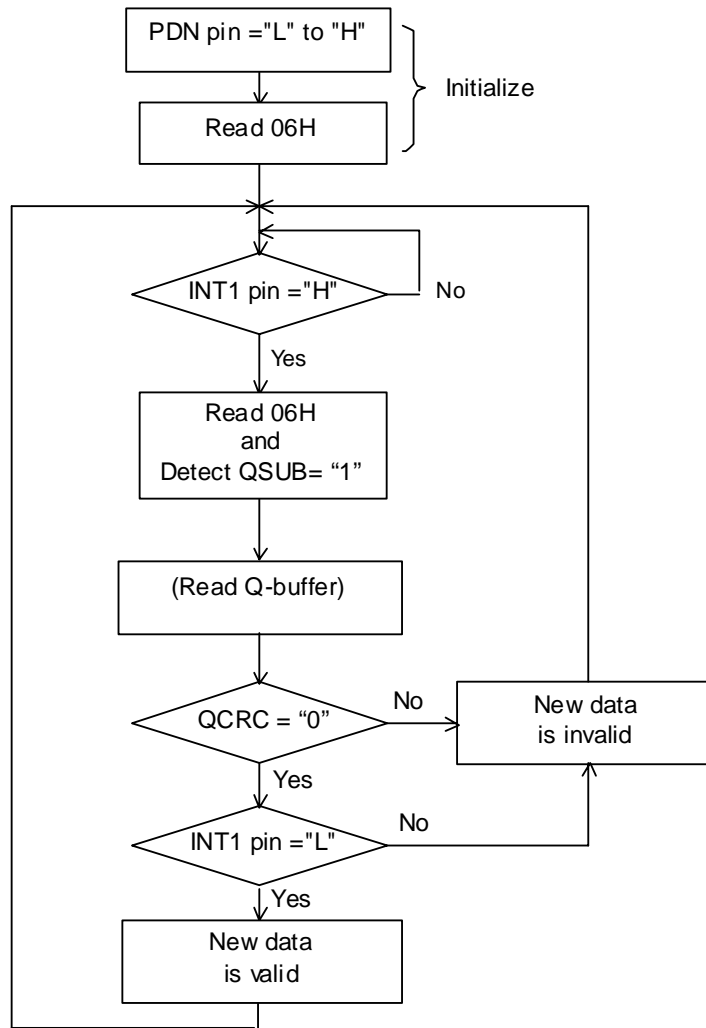

Figure 31. Error Handling Sequence Example 2 (for Q/CINT)

■ Audio Serial Interface Format

The DIF0, DIF1 and DIF2 pins can select eight serial data formats as shown in Table 29. In all formats the serial data is MSB-first, 2's complement format. The SDTO2 is clocked out on the falling edge of BICK2 and the DAUX2 is latched on the rising edge of BICK2. BICK2 outputs 64fs clock in Mode 0-5. Mode 6-7 are Slave Modes, and BICK2 is available up to 128fs at fs=48kHz. In the format equal or less than 20bit (Mode0-2), LSBs in sub-frame are truncated. In Mode 3-7, the last 4LSBs are auxiliary data (see Figure 32).

**When using Master mode, BICK2 and KRCK2 output pins are Hi-Z during PDN pin = “L” and from PDN pin = “H” to entering Master mode.**

When the Parity Error, Biphasic Error or Frame Length Error occurs in a sub-frame, AK4589 continues to output the last normal sub-frame data from SDTO2 repeatedly until the error is removed. When the Unlock Error occurs, AK4589 output “0” from SDTO2. In case of using DAUX2 pin, the data is transformed and output from SDTO2. DAUX2 pin is used in Clock Operation Mode 1, 3 and unlock state of Mode 2.

The input data format to DAUX2 should be left justified except in Mode5 and 7(Table 29). In Mode5 or 7, both the input data format of DAUX2 and output data format of SDTO2 are I<sup>2</sup>S. Mode6 and 7 are Slave Mode that is corresponding to the Master Mode of Mode4 and 5. In salve Mode, LRCK2 and BICK2 should be fed with synchronizing to MCKO1/2.

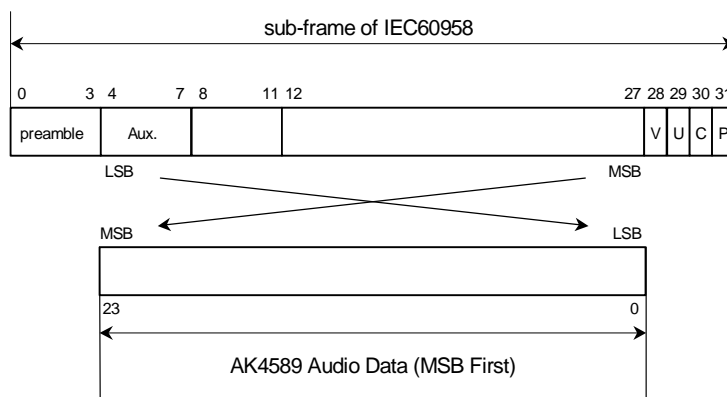

Figure 32. Bit configuration

Mode	DIF2	DIF1	DIF0	DAUX2	SDTO2	LRCK2		BICK2	
							I/O		I/O
0	0	0	0	24bit, Left justified	16bit, Right justified	H/L	O	64fs	O
1	0	0	1	24bit, Left justified	18bit, Right justified	H/L	O	64fs	O
2	0	1	0	24bit, Left justified	20bit, Right justified	H/L	O	64fs	O
3	0	1	1	24bit, Left justified	24bit, Right justified	H/L	O	64fs	O
4	1	0	0	24bit, Left justified	24bit, Left justified	H/L	O	64fs	O
5	1	0	1	24bit, I <sup>2</sup> S	24bit, I <sup>2</sup> S	L/H	O	64fs	O
6	1	1	0	24bit, Left justified	24bit, Left justified	H/L	I	64-128fs	I
7	1	1	1	24bit, I <sup>2</sup> S	24bit, I <sup>2</sup> S	L/H	I	64-128fs	I

Default

Table 29. Audio data format

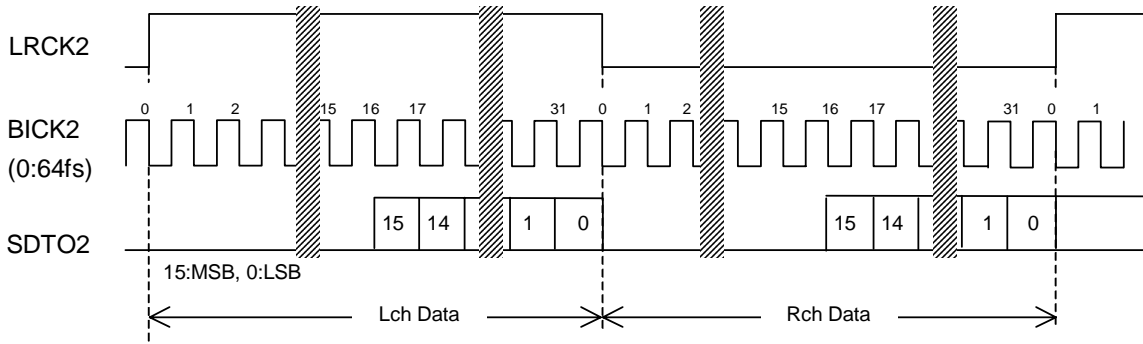

Figure 33. Mode 0 Timing

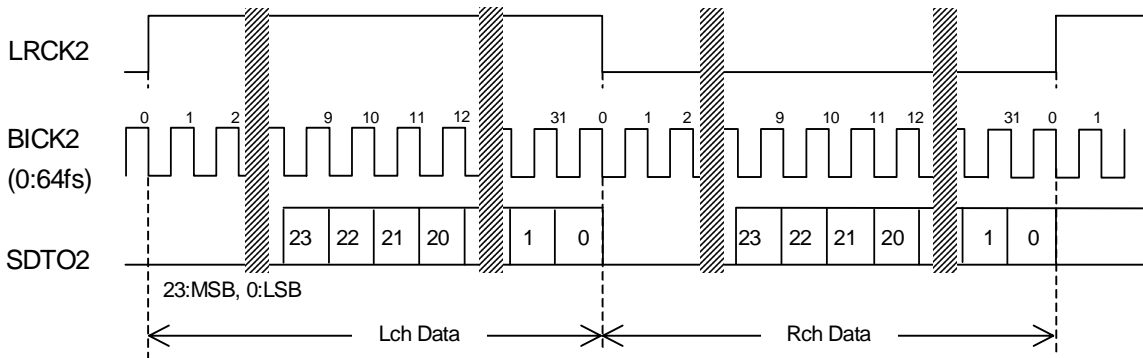

Figure 34. Mode 3 Timing

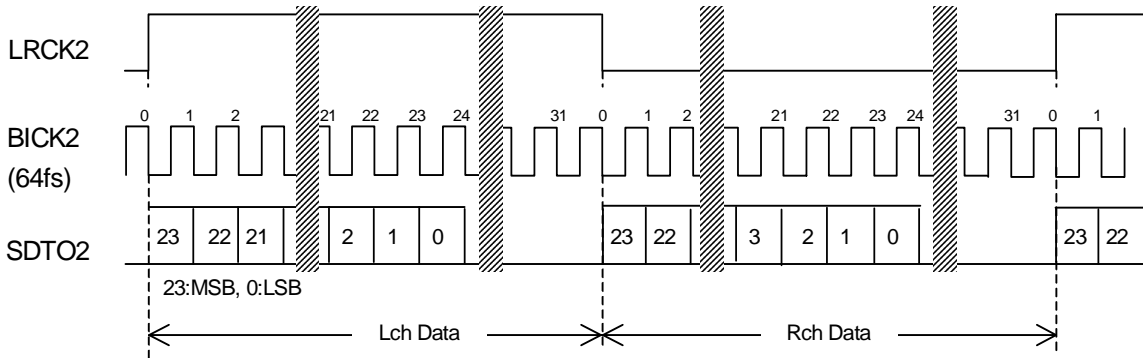

Figure 35. Mode 4, 6 Timing

Mode4 : LRCK2, BICK2 : Output  
 Mode6 : LRCK2, BICK2 : Input

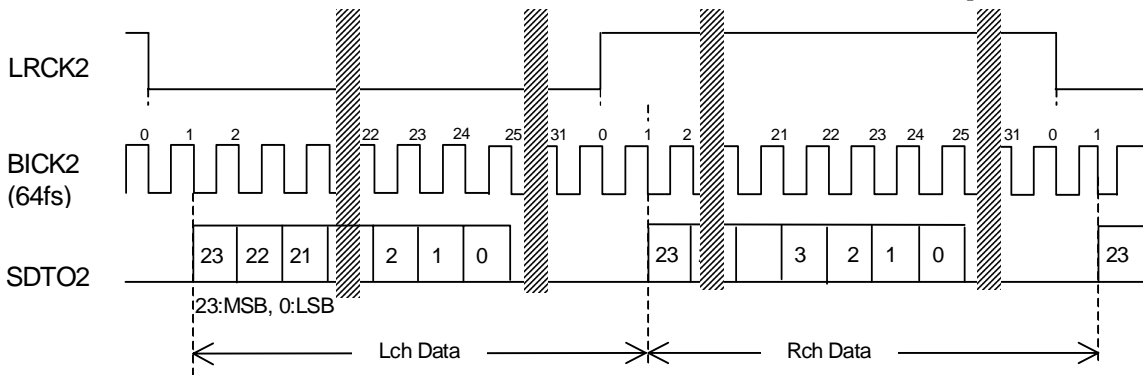

Figure 36. Mode 5, 7 Timing

Mode5 : LRCK2, BICK2 : Output  
 Mode7 : LRCK2, BICK2 : Input



## ■ Register Map

Addr	Register Name	D7	D6	D5	D4	D3	D2	D1	D0
00H	CLK & Power Down Control	CS12	BCU	CM1	CM0	OCKS1	OCKS0	PWN	RSTN2
01H	Format & De-em Control	0	DIF2	DIF1	DIF0	DEAU	DEM1	DEM0	DFS
02H	Input/ Output Control 0	TX1E	OPS12	OPS11	OPS10	TX0E	OPS02	OPS01	OPS00
03H	Input/ Output Control 1	EFH1	EFH0	UDIT	0	DIT	IPS2	IPS1	IPS0
04H	INT0 MASK	MQIT0	MAUT0	MCIT0	MULK0	MDTS0	MPE0	MAUD0	MPAR0
05H	INT1 MASK	MQIT1	MAUT1	MCIT1	MULK1	MDTS1	MPE1	MAUD1	MPAR1
06H	Receiver status 0	QINT	AUTO	CINT	UNLCK	DTSCD	PEM	AUDION	PAR
07H	Receiver status 1	FS3	FS2	FS1	FS0	0	V	QCRC	CCRC
08H	RX Channel Status Byte 0	CR7	CR6	CR5	CR4	CR3	CR2	CR1	CR0
09H	RX Channel Status Byte 1	CR15	CR14	CR13	CR12	CR11	CR10	CR9	CR8
0AH	RX Channel Status Byte 2	CR23	CR22	CR21	CR20	CR19	CR18	CR17	CR16
0BH	RX Channel Status Byte 3	CR31	CR30	CR29	CR28	CR27	CR26	CR25	CR24
0CH	RX Channel Status Byte 4	CR39	CR38	CR37	CR36	CR35	CR34	CR33	CR32
0DH	TX Channel Status Byte 0	CT7	CT6	CT5	CT4	CT3	CT2	CT1	CT0
0EH	TX Channel Status Byte 1	CT15	CT14	CT13	CT12	CT11	CT10	CT9	CT8
0FH	TX Channel Status Byte 2	CT23	CT22	CT21	CT20	CT19	CT18	CT17	CT16
10H	TX Channel Status Byte 3	CT31	CT30	CT29	CT28	CT27	CT26	CT25	CT24
11H	TX Channel Status Byte 4	CT39	CT39	CT39	CT39	CT39	CT39	CT39	CT32
12H	Burst Preamble Pc Byte 0	PC7	PC6	PC5	PC4	PC3	PC2	PC1	PC0
13H	Burst Preamble Pc Byte 1	PC15	PC14	PC13	PC12	PC11	PC10	PC9	PC8
14H	Burst Preamble Pd Byte 0	PD7	PD6	PD5	PD4	PD3	PD2	PD1	PD0
15H	Burst Preamble Pd Byte 1	PD15	PD14	PD13	PD12	PD11	PD10	PD9	PD8
16H	Q-subcode Address / Control	Q9	Q8	Q7	Q6	Q5	Q4	Q3	Q2
17H	Q-subcode Track	Q17	Q16	Q15	Q14	Q13	Q12	Q11	Q10
18H	Q-subcode Index	Q25	Q24	Q23	Q22	Q21	Q20	Q19	Q18
19H	Q-subcode Minute	Q33	Q32	Q31	Q30	Q29	Q28	Q27	Q26
1AH	Q-subcode Second	Q41	Q40	Q39	Q38	Q37	Q36	Q35	Q34
1BH	Q-subcode Frame	Q49	Q48	Q47	Q46	Q45	Q44	Q43	Q42
1CH	Q-subcode Zero	Q57	Q56	Q55	Q54	Q53	Q52	Q51	Q50
1DH	Q-subcode ABS Minute	Q65	Q64	Q63	Q62	Q61	Q60	Q59	Q58
1EH	Q-subcode ABS Second	Q73	Q72	Q71	Q70	Q69	Q68	Q67	Q66
1FH	Q-subcode ABS Frame	Q81	Q80	Q79	Q78	Q77	Q76	Q75	Q74

When PDN pin goes “L”, the registers are initialized to their default values.

When RSTN bit goes “0”, the internal timing is reset and the registers are initialized to their default values.

All data can be written to the register even if PWN bit is “0”.

01H D7 and 03H D4 should be written “0” data.

## ■ Register Definitions

### Reset & Initialize

Addr	Register Name	D7	D6	D5	D4	D3	D2	D1	D0
00H	CLK & Power Down Control	CS12	BCU	CM1	CM0	OCKS1	OCKS0	PWN	RSTN2
	R/W	R/W	R/W	R/W	R/W	R/W	R/W	R/W	R/W
	Default	0	1	0	0	0	0	1	1

RSTN2: Timing Reset & Register Initialize

0: Reset & Initialize

1: Normal Operation

PWN: Power Down

0: Power Down

1: Normal Operation

OCKS1-0: Master Clock Frequency Select

CM1-0: Master Clock Operation Mode Select

BCU: Block start & C/U Output Mode

When BCU=1, the three Output Pins(BOUT, COUT, UOUT) become to be enabled.

The block signal goes high at the start of frame 0 and remains high until the end of frame 31.

CS12: Channel Status Select

0: Channel 1

1: Channel 2

Selects which channel status is used to derive C-bit buffers, AUDION, PEM, FS3, FS2, FS1, FS0, Pc and Pd. The de-emphasis filter is controlled by channel 1 in the Parallel Mode.

### Format & De-emphasis Control

Addr	Register Name	D7	D6	D5	D4	D3	D2	D1	D0
01H	Format & De-em Control	0	DIF2	DIF1	DIF0	DEAU	DEM1	DEM0	DFS
	R/W	RD	R/W	R/W	R/W	R/W	R/W	R/W	R/W
	Default	0	1	1	0	1	0	1	0

DFS: 96kHz De-emphasis Control

DEM1-0: 32, 44.1, 48kHz De-emphasis Control (see Table 24.)

DEAU: De-emphasis Auto Detect Enable

0: Disable

1: Enable

DIF2-0: Audio Data Format Control (see Table 29.)

**Input/Output Control**

Addr	Register Name	D7	D6	D5	D4	D3	D2	D1	D0
02H	Input/ Output Control 0	TX1E	OPS12	OPS11	OPS10	TX0E	OPS02	OPS01	OPS00
	R/W	R/W	R/W	R/W	R/W	R/W	R/W	R/W	R/W
	Default	1	0	0	0	1	0	0	0

OPS02-00: Output Through Data Select for TX0 pin

OPS12-10: Output Through Data Select for TX1 pin

TX0E: TX0 Output Enable

0: Disable. TX0 pin outputs "L".

1: Enable

TX1E: TX1 Output Enable

0: Disable. TX1 pin outputs "L".

1: Enable

Addr	Register Name	D7	D6	D5	D4	D3	D2	D1	D0
03H	Input/ Output Control 1	EFH1	EFH0	UDIT	0	DIT	IPS2	IPS1	IPS0
	R/W	R/W	R/W	R/W	RD	R/W	R/W	R/W	R/W
	Default	0	1	0	0	1	0	0	0

IPS2-0: Input Recovery Data Select

DIT: Through data/Transmit data select for TX1 pin

0: Through data (RX data).

1: Transmit data (DAUX2 data).

UDIT: U bit control for DIT

0: U bit is fixed to "0"      1: Recovered U bit is used for DIT (loop mode for U bit)

EFH1-0: Interrupt 0 Pin Hold Count Select

00: 512 LRCK2                  01: 1024 LRCK2

10: 2048 LRCK2                11: 4096 LRCK2

**Mask Control for INT0**

Addr	Register Name	D7	D6	D5	D4	D3	D2	D1	D0
04H	INT0 MASK	MQI0	MAT0	MCI0	MUL0	MDTS0	MPE0	MAN0	MPR0
	R/W	R/W	R/W	R/W	R/W	R/W	R/W	R/W	R/W
	Default	1	1	1	0	1	1	1	0

- MPR0: Mask Enable for PAR bit
- MAN0: Mask Enable for AUDN bit
- MPE0: Mask Enable for PEM bit
- MDTS0: Mask Enable for DTSCD bit
- MUL0: Mask Enable for UNLOCK bit
- MCI0: Mask Enable for CINT bit
- MAT0: Mask Enable for AUTO bit
- MQI0: Mask Enable for QINT bit

0: Mask disable  
 1: Mask enable

**Mask Control for INT1**

Addr	Register Name	D7	D6	D5	D4	D3	D2	D1	D0
05H	INT1 MASK	MQI1	MAT1	MCI1	MUL1	MDTS1	MPE1	MAN1	MPR1
	R/W	R/W	R/W	R/W	R/W	R/W	R/W	R/W	R/W
	Default	1	0	1	1	0	1	0	1

- MPR1: Mask Enable for PAR bit
- MAN1: Mask Enable for AUDN bit
- MPE1: Mask Enable for PEM bit
- MDTS1: Mask Enable for DTSCD bit
- MUL1: Mask Enable for UNLOCK0 bit
- MCI1: Mask Enable for CINT bit
- MAT1: Mask Enable for AUTO bit
- MQI1: Mask Enable for QINT bit

0: Mask disable  
 1: Mask enable

**Receiver Status 0**

Addr	Register Name	D7	D6	D5	D4	D3	D2	D1	D0
06H	Receiver status 0	QINT	AUTO	CINT	UNLCK	DTSCD	PEM	AUDION	PAR
	R/W	RD	RD	RD	RD	RD	RD	RD	RD
	Default	0	0	0	0	0	0	0	0

PAR: Parity Error or Biphas Error Status  
 0:No Error                      1:Error  
 It is "1" if Parity Error or Biphas Error is detected in the sub-frame.

AUDION: Audio Bit Output  
 0: Audio                          1: Non Audio  
 This bit is made by encoding channel status bits.

PEM: Pre-emphasis Detect.  
 0: OFF                              1: ON  
 This bit is made by encoding channel status bits.

DTSCD: DTS-CD Auto Detect  
 0: No detect                      1: Detect

UNLCK: PLL Lock Status  
 0: Locked                          1: Out of Lock

CINT: Channel Status Buffer Interrupt  
 0: No change                      1: Changed

AUTO: Non-PCM Auto Detect  
 0: No detect                      1: Detect

QINT: Q-subcode Buffer Interrupt  
 0: No change                      1: Changed

QINT, CINT and PAR bits are initialized when 06H is read.

**Receiver Status 1**

Addr	Register Name	D7	D6	D5	D4	D3	D2	D1	D0
07H	Receiver status 1	FS3	FS2	FS1	FS0	0	V	QCRC	CCRC
	R/W	RD	RD	RD	RD	RD	RD	RD	RD
	Default	0	0	0	1	0	0	0	0

CCRC: Cyclic Redundancy Check for Channel Status  
 0:No Error                      1:Error

QCRC: Cyclic Redundancy Check for Q-subcode  
 0:No Error                      1:Error

V: Validity of channel status  
 0:Valid                              1:Invalid

FS3-0: Sampling Frequency detection (see Table 20.)

**Receiver Channel Status**

Addr	Register Name	D7	D6	D5	D4	D3	D2	D1	D0
08H	RX Channel Status Byte 0	CR7	CR6	CR5	CR4	CR3	CR2	CR1	CR0
09H	RX Channel Status Byte 1	CR15	CR14	CR13	CR12	CR11	CR10	CR9	CR8
0AH	RX Channel Status Byte 2	CR23	CR22	CR21	CR20	CR19	CR18	CR17	CR16
0BH	RX Channel Status Byte 3	CR31	CR30	CR29	CR28	CR27	CR26	CR25	CR24
0CH	RX Channel Status Byte 4	CR39	CR38	CR37	CR36	CR35	CR34	CR33	CR32
R/W		RD							
Default		Not initialized							

CR39-0: Receiver Channel Status Byte 4-0

**Transmitter Channel Status**

Addr	Register Name	D7	D6	D5	D4	D3	D2	D1	D0
0DH	TX Channel Status Byte 0	CT7	CT6	CT5	CT4	CT3	CT2	CT1	CT0
0EH	TX Channel Status Byte 1	CT15	CT14	CT13	CT12	CT11	CT10	CT9	CT8
0FH	TX Channel Status Byte 2	CT23	CT22	CT21	CT20	CT19	CT18	CT17	CT16
10H	TX Channel Status Byte 3	CT31	CT30	CT29	CT28	CT27	CT26	CT25	CT24
11H	TX Channel Status Byte 3	CT39	CT38	CT37	CT36	CT35	CT34	CT33	CT32
R/W		R/W							
Default		0							

CT39-0: Transmitter Channel Status Byte 4-0

**Burst Preamble Pc/Pd in non-PCM encoded Audio Bitstreams**

Addr	Register Name	D7	D6	D5	D4	D3	D2	D1	D0
12H	Burst Preamble Pc Byte 0	PC7	PC6	PC5	PC4	PC3	PC2	PC1	PC0
13H	Burst Preamble Pc Byte 1	PC15	PC14	PC13	PC12	PC11	PC10	PC9	PC8
14H	Burst Preamble Pd Byte 0	PD7	PD6	PD5	PD4	PD3	PD2	PD1	PD0
15H	Burst Preamble Pd Byte 1	PD15	PD14	PD13	PD12	PD11	PD10	PD9	PD8
R/W		RD							
Default		Not initialized							

PC15-0: Burst Preamble Pc Byte 0 and 1

PD15-0: Burst Preamble Pd Byte 0 and 1

**Q-subcode Buffer**

Addr	Register Name	D7	D6	D5	D4	D3	D2	D1	D0
16H	Q-subcode Address / Control	Q9	Q8	Q7	Q6	Q5	Q4	Q3	Q2
17H	Q-subcode Track	Q17	Q16	Q15	Q14	Q13	Q12	Q11	Q10
18H	Q-subcode Index	Q25	Q24	Q23	Q22	Q21	Q20	Q19	Q18
19H	Q-subcode Minute	Q33	Q32	Q31	Q30	Q29	Q28	Q27	Q26
1AH	Q-subcode Second	Q41	Q40	Q39	Q38	Q37	Q36	Q35	Q34
1BH	Q-subcode Frame	Q49	Q48	Q47	Q46	Q45	Q44	Q43	Q42
1CH	Q-subcode Zero	Q57	Q56	Q55	Q54	Q53	Q52	Q51	Q50
1DH	Q-subcode ABS Minute	Q65	Q64	Q63	Q62	Q61	Q60	Q59	Q58
1EH	Q-subcode ABS Second	Q73	Q72	Q71	Q70	Q69	Q68	Q67	Q66
1FH	Q-subcode ABS Frame	Q81	Q80	Q79	Q78	Q77	Q76	Q75	Q74
R/W		RD							
Default		Not initialized							

■ Burst Preambles in non-PCM Bitstreams

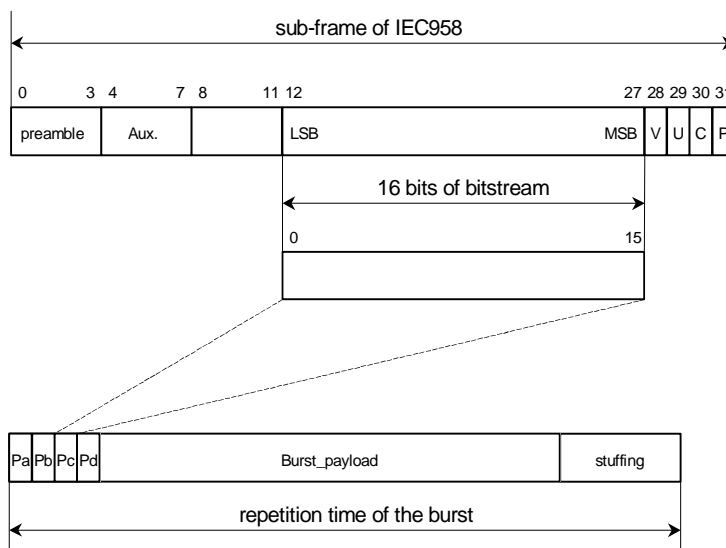

Figure 37. Data structure in IEC60958

Preamble word	Length of field	Contents	Value
Pa	16 bits	sync word 1	0xF872
Pb	16 bits	sync word 2	0x4E1F
Pc	16 bits	Burst info	see Table 31
Pd	16 bits	Length code	Numbers of bits

Table 30. Burst preamble words



Bits of Pc	Value	Contents	Repetition time of burst in IEC60958 frames
0-4	0	data type NULL data	≤4096
	1	Dolby AC-3 data	1536
	2	reserved	
	3	PAUSE	
	4	MPEG-1 Layer1 data	384
	5	MPEG-1 Layer2 or 3 data or MPEG-2 without extension	1152
	6	MPEG-2 data with extension	1152
	7	MPEG-2 AAC ADTS	1024
	8	MPEG-2, Layer1 Low sample rate	384
	9	MPEG-2, Layer2 or 3 Low sample rate	1152
	10	reserved	
	11	DTS type I	512
	12	DTS type II	1024
	13	DTS type III	2048
	14	ATRAC	512
	15	ATRAC2/3	1024
16-31	reserved		
5, 6	0	reserved, shall be set to "0"	
7	0	error-flag indicating a valid burst_payload	
	1	error-flag indicating that the burst_payload may contain errors	
8-12		data type dependent info	
13-15	0	bit stream number, shall be set to "0"	

Table 31. Fields of burst info Pc

■ Non-PCM Bitstream timing

1) When Non-PCM preamble is not coming within 4096 frames,

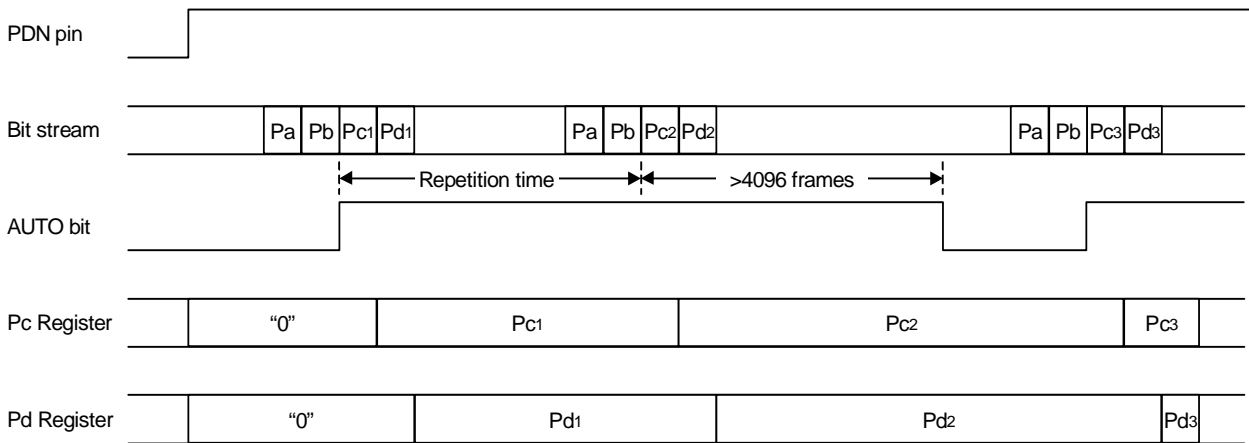

Figure 38. Timing example 1

2) When Non-PCM bitstream stops (when MULK0=0),

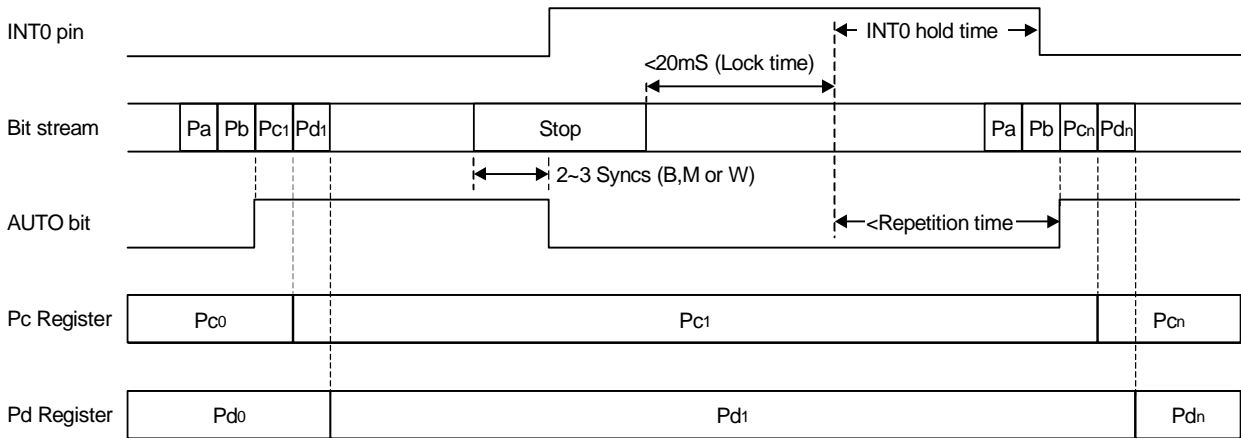

Figure 39. Timing example 2

**OPERATION OVERVIEW (ADC/DAC part, DIR/DIT part)**

■ **Serial Control Interface**

The AK4589 has two registers, which are ADC/DAC part (AK4588 compatible) and DIR/DIT part (AK4588 compatible). Each register is set by chip address pin.

(1) 4-wire serial control mode (I2C pin = "L")

The internal registers may be either written or read by the 4-wire  $\mu$ P interface pins: CSN, CCLK, CDTI & CDTO. The data on this interface consists of Chip address (2bits, ADC/DAC part register is set by CAD1/0 pins. DIR/DIT part C1-0 bits are fixed to "00"), Read/Write (1bit), Register address (MSB first, 5bits) and Control data (MSB first, 8bits). Address and data is clocked in on the rising edge of CCLK and data is clocked out on the falling edge. For write operations, data is latched after the 16th rising edge of CCLK, after a high-to-low transition of CSN. For read operations, the CDTO output goes high impedance after a low-to-high transition of CSN. The maximum speed of CCLK is 5MHz. PDN pin = "L" resets the registers to their default values. When the state of P/S pin is changed, the AK4589 should be reset by PDN pin = "L". Register of ADC/DAC part can not read.

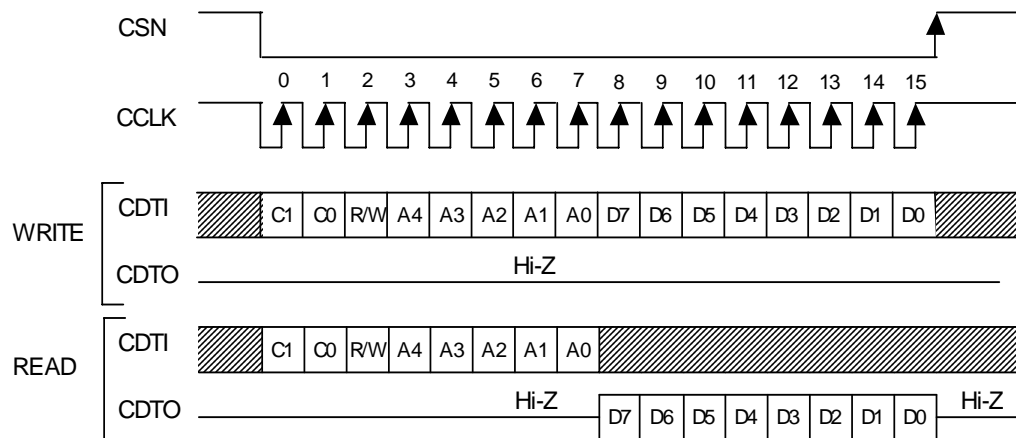

- C1-C0: Chip Address: (Regarding ADC/DAC part, register is set by CAD1/0 pins. This chip address must be set except "00".)  
(Fixed to "00" for DIR/DIT part)
- R/W: READ/WRITE (0:READ, 1:WRITE)
- A4-A0: Register Address
- D7-D0: Control Data

Figure 40. 4-wire Serial Control I/F Timing

(2) I<sup>2</sup>C bus control mode (I2C pin = “H”)

AK4589 supports the standard-mode I<sup>2</sup>C-bus (max: 100kHz). Then AK4589 does not support a fast-mode I<sup>2</sup>C-bus system (max: 400kHz).

(2)-1 Data transfer

All commands are preceded by a START condition. After the START condition, a slave address is sent. After the AK4589 recognizes the START condition, the device interfaced to the bus waits for the slave address to be transmitted over the SDA line. If the transmitted slave address matches an address for one of the devices, the designated slave device pulls the SDA line to LOW (ACKNOWLEDGE). The data transfer is always terminated by a STOP condition generated by the master device.

(2)-1-1 Data validity

The data on the SDA line must be stable during the HIGH period of the clock. The HIGH or LOW state of the data line can only change when the clock signal on the SCL line is LOW except for the START and the STOP condition.

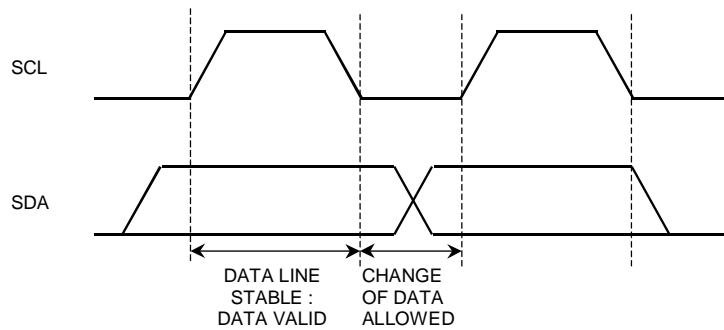

Figure 41. Data transfer

(2)-1-2 START and STOP condition

A HIGH to LOW transition on the SDA line while SCL is HIGH indicates a START condition. All sequences start from the START condition.

A LOW to HIGH transition on the SDA line while SCL is HIGH defines a STOP condition. All sequences end by the STOP condition.

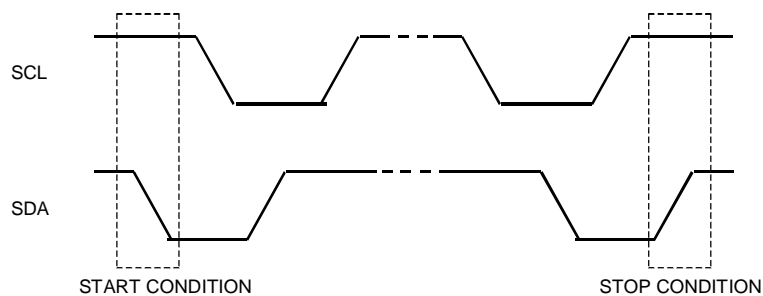

Figure 42. START and STOP conditions

(2)-1-3 ACKNOWLEDGE

ACKNOWLEDGE is a software convention used to indicate successful data transfers. The transmitting device will release the SDA line (HIGH) after transmitting eight bits. The receiver must pull down the SDA line during the acknowledge clock pulse so that that it remains stable “L” during “H” period of this clock pulse. The AK4589 will generate an acknowledge after each byte has been received.

In the read mode, the slave, the AK4589 will transmit eight bits of data, release the SDA line and monitor the line for an acknowledge. If an acknowledge is detected and no STOP condition is generated by the master, the slave will continue to transmit data. If an acknowledge is not detected, the slave will terminate further data transmissions and await the STOP condition.

**The register of ADC/DAC part can not generate acknowledge for READ operations.**

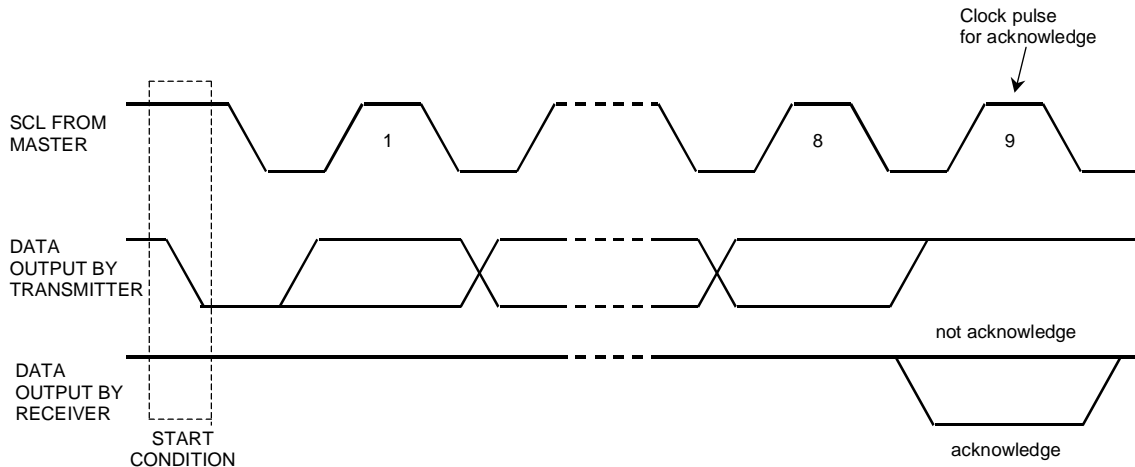

Figure 43. Acknowledge on the I<sup>2</sup>C-bus

(2)-1-4 FIRST BYTE

The first byte, which includes seven bits of slave address and one bit of R/W bit, is sent after the START condition. If the transmitted slave address matches an address for one of the device, the receiver who has been addressed pulls down the SDA line.

The most significant five bits of the slave address are fixed as “00100”. The next two bits are CAD1 and CAD0 (device address bits). These two bits identify the specific device on the bus. The hard-wired input pins (CAD1 pin and CAD0 pin) set them. The eighth bit (LSB) of the first byte (R/W bit) defines whether a write or read condition is requested by the master. A “1” indicates that the read operation is to be executed. A “0” indicates that the write operation is to be executed.

0	0	1	0	0	CAD1	CAD0	R/W
---	---	---	---	---	------	------	-----

(Regarding ADC/DAC part, register is set by CAD1/0 pins.  
 “00” is inhibited to set for ADC/DAC.)  
 (Fixed to “00” for DIR/DIT part)

Figure 44. The First Byte

(2)-2 WRITE Operations

Set R/W bit = "0" for the WRITE operation of the AK4589.

After receipt the start condition and the first byte, the AK4589 generates an acknowledge, and awaits the second byte (register address). The second byte consists of the address for control registers of AK4589. The format is MSB first, and those most significant 3-bits are "Don't care".

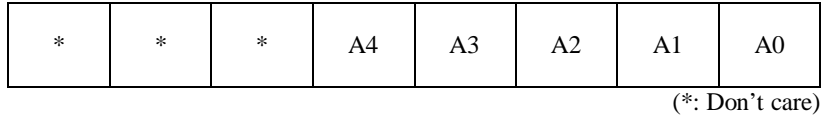

Figure 45. The Second Byte

After receipt the second byte, the AK4589 generates an acknowledge, and awaits the third byte. Those data after the second byte contain control data. The format is MSB first, 8bits.

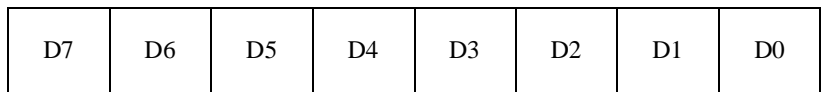

Figure 46. Byte structure after the second byte

The AK4589 is capable of more than one byte write operation by one sequence.

After receipt of the third byte, the AK4589 generates an acknowledge, and awaits the next data again. The master can transmit more than one words instead of terminating the write cycle after the first data word is transferred. After the receipt of each data, the internal 5bits address counter is incremented by one, and the next data is taken into next address automatically. If the address exceed 1FH prior to generating the stop condition, the address counter will "roll over" to 00H and the previous data will be overwritten.

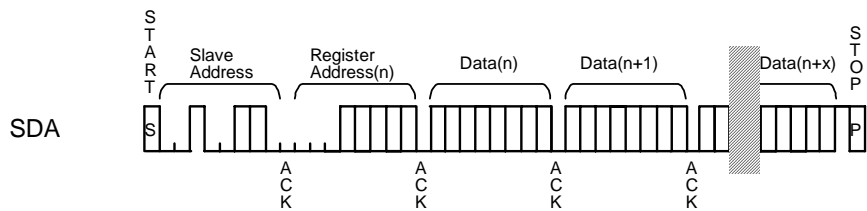

Figure 47. WRITE Operation

(2)-3 READ Operations

Set R/W bit = “1” for the READ operation of the AK4589.

After transmission of a data, the master can read next address’s data by generating the acknowledge instead of terminating the write cycle after the receipt the first data word. After the receipt of each data, the internal 5bits address counter is incremented by one, and the next data is taken into next address automatically. If the address exceed 1FH prior to generating the stop condition, the address counter will “roll over” to 00H and the previous data will be overwritten.

The AK4589 supports two basic read operations: CURRENT ADDRESS READ and RANDOM READ.  
ADC/DAC part register can not read.

(2)-3-1 CURRENT ADDRESS READ

The AK4589 contains an internal address counter that maintains the address of the last word accessed, incremented by one. Therefore, if the last access (either a read or write) was to address n, the next CURRENT READ operation would access data from the address n+1.

After receipt of the slave address with R/W bit set to “1”, the AK4589 generates an acknowledge, transmits 1byte data which address is set by the internal address counter and increments the internal address counter by 1. If the master does not generate an acknowledge to the data but generate the stop condition, the AK4589 discontinues transmission

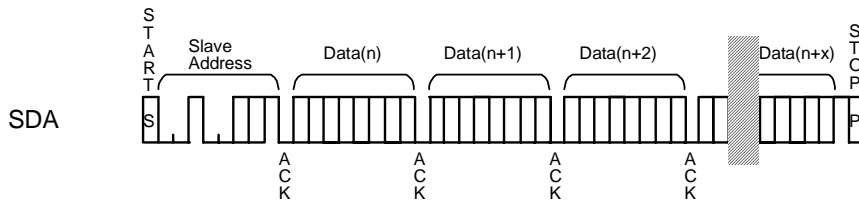

Figure 48. CURRENT ADDRESS READ

(2)-3-2 RANDOM READ

Random read operation allows the master to access any memory location at random. Prior to issuing the slave address with the R/W bit set to “1”, the master must first perform a “dummy” write operation.

The master issues the start condition, slave address(R/W=“0”) and then the register address to read. After the register address’s acknowledge, the master immediately reissues the start condition and the slave address with the R/W bit set to “1”. Then the AK4589 generates an acknowledge, 1byte data and increments the internal address counter by 1. If the master does not generate an acknowledge to the data but generate the stop condition, the AK4589 discontinues transmission.

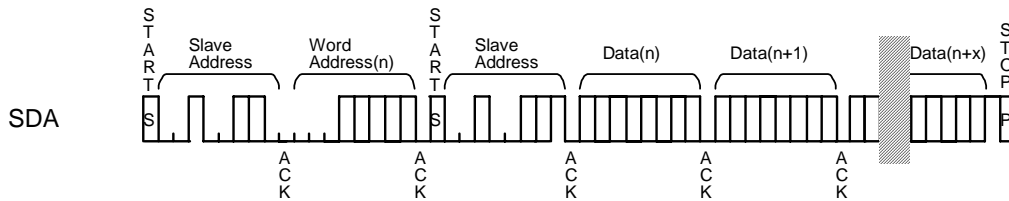

Figure 49. RANDOM READ

**SYSTEM DESIGN**

Figure 50 shows the system connection diagram. An evaluation board is available which demonstrates application circuits, the optimum layout, power supply arrangements and measurement results.

Condition: I<sup>2</sup>C serial control mode

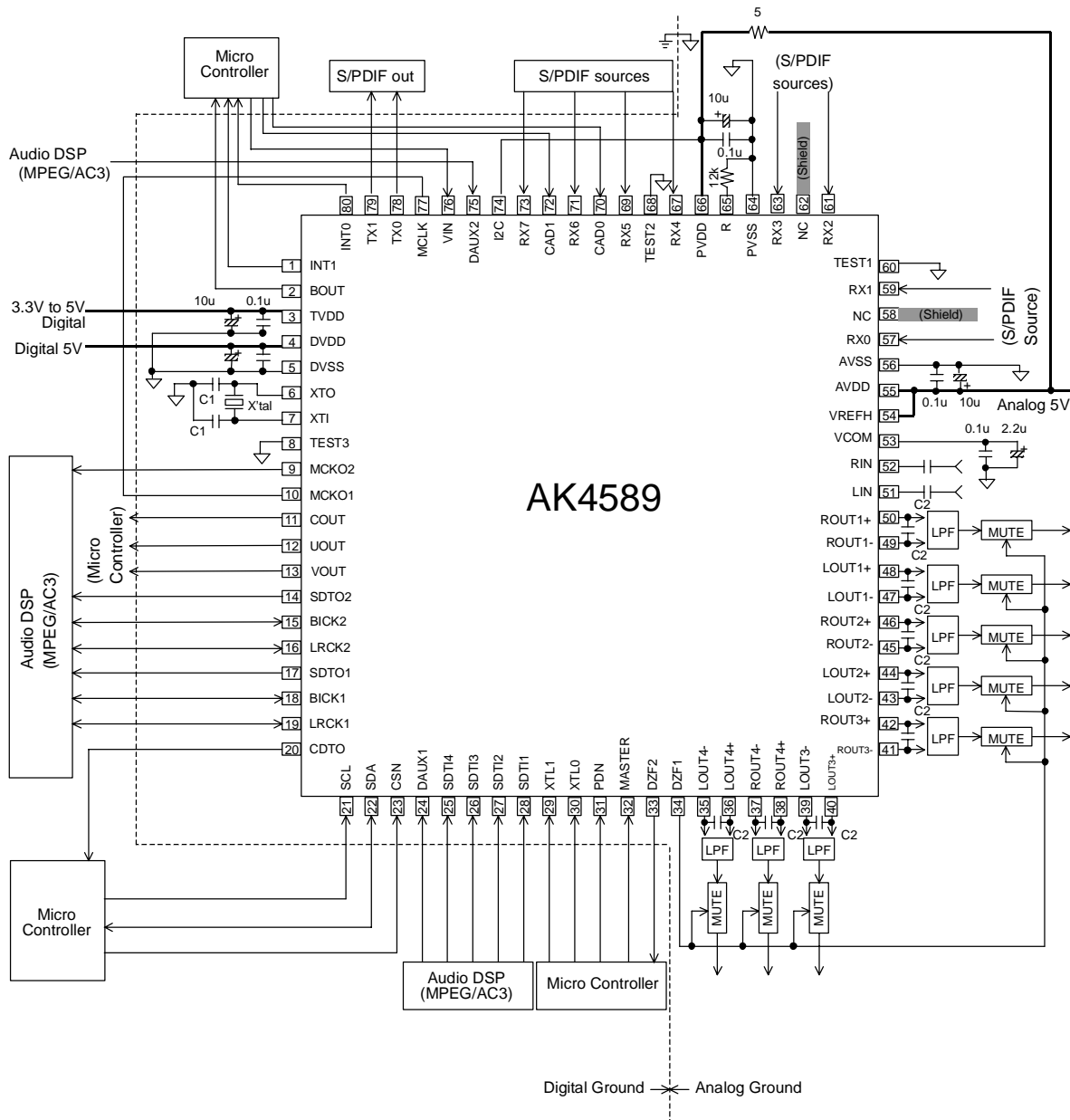

Figure 50. Typical Connection Diagram

Notes:

- "C1" depends on the crystal.
- "C2" is 470pF capacitor.
- AVSS, DVSS and PVSS must be connected the same analog ground plane.
- Digital signals, especially clocks, should be kept away from the R pin in order to avoid an effect to the clock jitter performance.
- In case of coaxial input, ground of RCA connector and terminator should be connected to PVSS of the AK4589 with low impedance on PC board.



## 1. Grounding and Power Supply Decoupling

The AK4589 requires careful attention to power supply and grounding arrangements. AVDD, DVDD, PVDD and TVDD are usually supplied from analog supply in system. Alternatively if AVDD, DVDD, PVDD and TVDD are supplied separately, the power up sequence is not critical. **AVSS, DVSS and PVSS of the AK4589 must be connected to analog ground plane.** System analog ground and digital ground should be connected together near to where the supplies are brought onto the printed circuit board. Decoupling capacitors should be as near to the AK4589 as possible, with the small value ceramic capacitor being the nearest.

## 2. Voltage Reference Inputs

The voltage of VREFH sets the analog input/output range. VREFH pin is normally connected to AVDD with a 0.1 $\mu$ F ceramic capacitor. VCOM is a signal ground of this chip. An electrolytic capacitor 2.2 $\mu$ F parallel with a 0.1 $\mu$ F ceramic capacitor attached to VCOM pin eliminates the effects of high frequency noise. No load current may be drawn from VCOM pin. All signals, especially clocks, should be kept away from the VREFH and VCOM pins in order to avoid unwanted coupling into the AK4589.

## 3. Analog Inputs

ADC inputs are single-ended and internally biased to VCOM. The input signal range scales with the supply voltage and nominally 0.62 x VREFH Vpp (typ). The ADC output data format is 2's complement. The DC offset is removed by the internal HPF.

The AK4589 samples the analog inputs at 64fs. The digital filter rejects noise above the stop band except for multiples of 64fs. The AK4589 includes an anti-aliasing filter (RC filter) to attenuate a noise around 64fs.

## 4. Analog Outputs

The analog outputs are differential output and centered around the VCOM voltage. The input signal range scales with the supply voltage and nominally 0.54 x VREFH Vpp. The DAC input data format is 2's complement. The output voltage is a positive full scale for 7FFFFFFH(@24bit) and a negative full scale for 800000H(@24bit). The ideal output is VCOM voltage for 000000H(@24bit). The internal analog filters remove most of the noise generated by the delta-sigma modulator of DAC beyond the audio passband.

DC offsets (AVDD/2) on analog outputs are eliminated without using capacitor. However AC coupling in Figure 51. External 2nd order LPF Circuit Example is recommended to achieve better performance.

**5. Analog Outputs**

Figure 51 shows an example of the Non-inverted differential output buffer and the summing amp with LPF. NJM5534D are op-amps that has low noise and +/- 15V power supply operation.

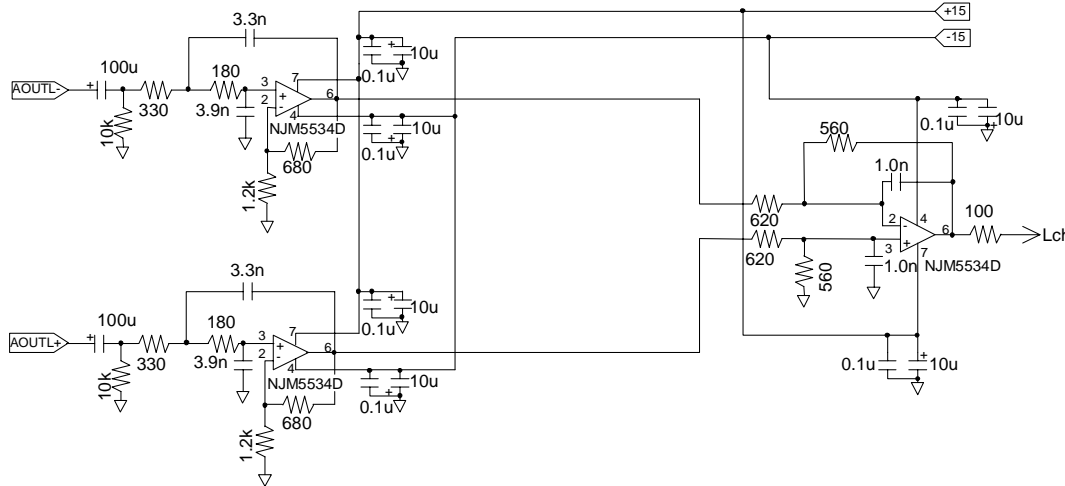
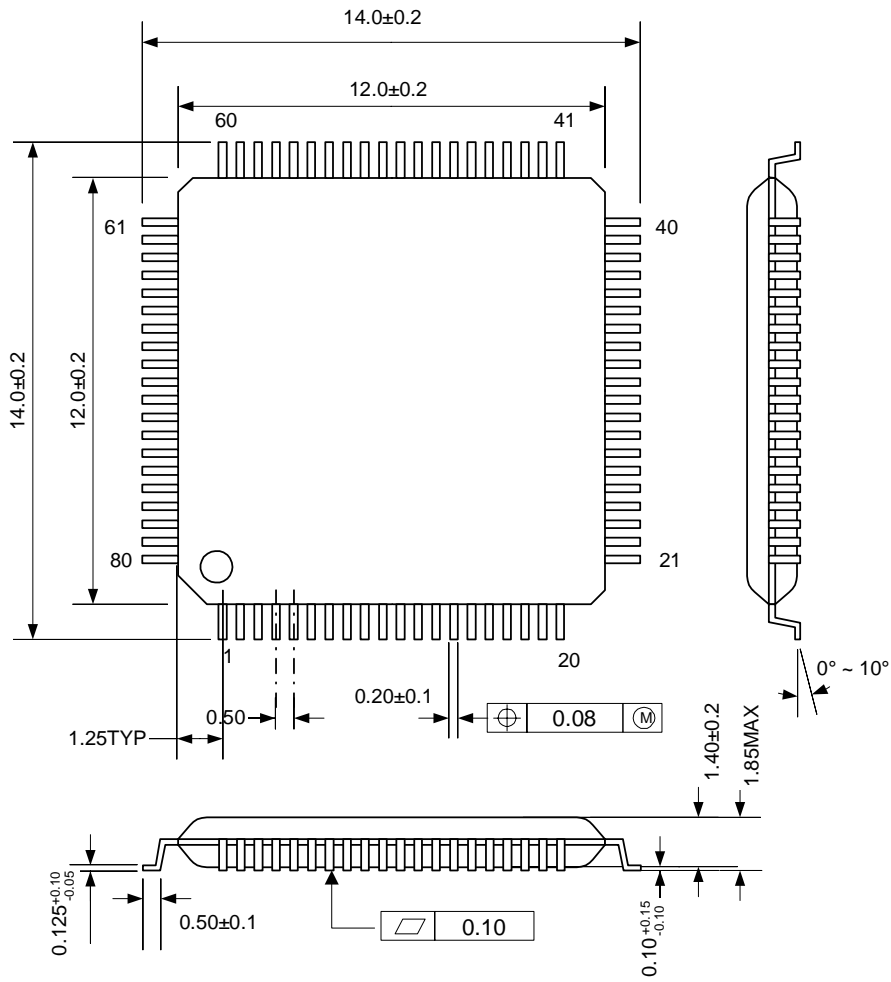

Figure 51. External 2nd order LPF Circuit Example

PACKAGE

- 80-pin LQFP (Unit : mm)



- Material & Lead finish

Package: Epoxy  
 Lead-frame: Copper  
 Lead-finish: Soldering (Pb free) plate

**MARKING**

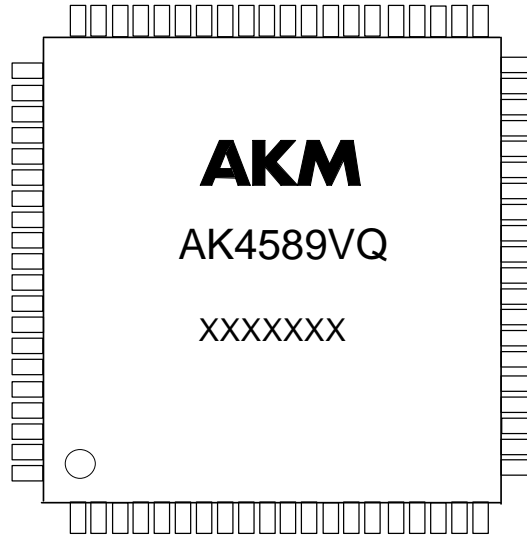

- 1) Pin #1 indication
- 2) Date Code: XXXXXXX(7 digits)
- 3) Marking Code: AK4589VQ
- 4) Asahi Kasei Logo

**Revision History**

Date (YY/MM/DD)	Revision	Reason	Page	Contents
04/09/06	00	First Edition		

**IMPORTANT NOTICE**

- These products and their specifications are subject to change without notice. Before considering any use or application, consult the Asahi Kasei Microsystems Co., Ltd. (AKM) sales office or authorized distributor concerning their current status.
- AKM assumes no liability for infringement of any patent, intellectual property, or other right in the application or use of any information contained herein.
- Any export of these products, or devices or systems containing them, may require an export license or other official approval under the law and regulations of the country of export pertaining to customs and tariffs, currency exchange, or strategic materials.
- AKM products are neither intended nor authorized for use as critical components in any safety, life support, or other hazard related device or system, and AKM assumes no responsibility relating to any such use, except with the express written consent of the Representative Director of AKM. As used here:
  - (a) A hazard related device or system is one designed or intended for life support or maintenance of safety or for applications in medicine, aerospace, nuclear energy, or other fields, in which its failure to function or perform may reasonably be expected to result in loss of life or in significant injury or damage to person or property.
  - (b) A critical component is one whose failure to function or perform may reasonably be expected to result, whether directly or indirectly, in the loss of the safety or effectiveness of the device or system containing it, and which must therefore meet very high standards of performance and reliability.
- It is the responsibility of the buyer or distributor of an AKM product who distributes, disposes of, or otherwise places the product with a third party to notify that party in advance of the above content and conditions, and the buyer or distributor agrees to assume any and all responsibility and liability for and hold AKM harmless from any and all claims arising from the use of said product in the absence of such notification.