



AK4955

24bit Stereo CODEC with MIC/SPK/Cap-less VIDEO-AMP/ LDO & DSP

GENERAL DESCRIPTION

The AK4955 is a 24bit stereo CODEC with a microphone amplifier, speaker amplifier, video amplifier, LDO, and DSP. The input circuits include a microphone amplifier and the output circuits include a speaker amplifier. It is suitable for portable application with recording/playback function. A one channel composite In/Out video amplifier is also integrated. The internal charge pump generates a negative power eliminating the need for AC-coupling capacitors. The AK4955 is available in a small 36pin CSP (3.0mm x 3.1mm, 0.5mm pitch), saving mounting area on the board.

FEATURES

1. Recording Functions

- Stereo Single-ended input with two Selectors
- MIC Amplifier (+24dB/+21dB/+18dB/+16dB/+14dB/+11dB/+8dB/+5dB/0dB)
- Digital ALC (Automatic Level Control)
(Setting Range: +36dB ~ -54dB, 0.375dB Step)
- ADC Performance: S/(N+D): 81dB, DR, S/N: 88dB (MIC-Amp=+18dB)
S/(N+D): 82dB, DR, S/N: 96dB (MIC-Amp=0dB)
- Microphone Sensitivity Compensation
- 5 Band Notch Filter
- Stereo Separation Emphasis Circuit
- Digital MIC Interface

2. Playback Functions

- Digital De-emphasis Filter (tc=50/15 μ s, fs=32kHz, 44.1kHz, 48kHz)
- Soft Mute
- Digital ALC (Automatic Level Control)
- Setting Range: +36dB ~ -54dB, 0.375dB Step
- Digital Volume Control (+12dB ~ -115dB, 0.5dB Step & Mute)
- Stereo Separation Emphasis Circuit
- Stereo Line Output
 - Output Voltage: +2dBV(1.26Vrms) (LVDD= 4.8V)
2.52Vpp (LVDD=3.3V)
 - S/(N+D): 85dB, S/N: 92dB
- Mono Mixing Output
- Mono Speaker-Amplifier
 - S/(N+D): 70dB@150mW, 60dB@250mW,
 - S/N: 95dB
 - BTL Output
 - Output Power: 600mW@8 Ω (SVDD=4.8V)
400mW@8 Ω (SVDD=3.3V)
- Analog Mixing: Mono Input
- Beep Generator

3. Power Management Function
 - Thermal Shut Down
4. Master Clock:
 - (1) PLL Mode
 - Frequencies: 11.2896MHz, 12MHz, 13.5MHz, 24MHz, 27MHz (MCKI pin)
32fs or 64fs (BICK pin)
 - (2) External Clock Mode
 - Frequencies: 256fs, 512fs or 1024fs (MCKI pin)
5. Output Master Clock Frequency: 32fs/64fs/128fs/256fs
6. Sampling Frequencies
 - PLL Slave Mode (BICK pin): 7.35kHz ~ 48kHz
 - PLL Slave Mode (MCKI pin):
8kHz, 11.025kHz, 12kHz, 16kHz, 22.05kHz, 24kHz, 32kHz, 44.1kHz, 48kHz
 - PLL Master Mode:
8kHz, 11.025kHz, 12kHz, 16kHz, 22.05kHz, 24kHz, 32kHz, 44.1kHz, 48kHz
 - EXT Master/Slave Mode:
7.35kHz ~ 48kHz (256fs), 7.35kHz ~ 48kHz (512fs), 7.35kHz ~ 13kHz (1024fs)
7. μ P I/F: 3-wire Serial, I²C Bus (Ver 1.0, 400kHz Fast-Mode)
8. Master/Slave Mode
9. Audio Interface Format: MSB First, 2's complement
 - ADC: 24bit MSB justified, 16/24bit I²S
 - DAC: 24bit MSB justified, 16bit LSB justified, 24bit LSB justified, 16/24bit I²S
10. Video Functions
 - One Composite Signal Input
 - Cap-less Video Amplifier for Composite Signal Output
Gain: +6 / +9 / +12 / +16.5dB
 - Low Pass Filter
 - Charge Pump Circuit for Negative Power Supply
11. Ta = -30 ~ 85°C
12. Power Supply:
 - Analog Power Supply (AVDD): 2.7 ~ 3.6V
 - Digital Power Supply (DVDD): 1.6 ~ 2.0V
 - Line Output Power Supply (LVDD): 2.7 ~ 5.5V
 - Speaker Power Supply (SVDD): 2.7 ~ 5.5V
 - Digital I/O Power Supply (TVDD): DVDD-0.2 ~ 3.6V
13. Package: 36pin CSP (3.0 x 3.1mm, 0.5mm pitch)

■ Block Diagram

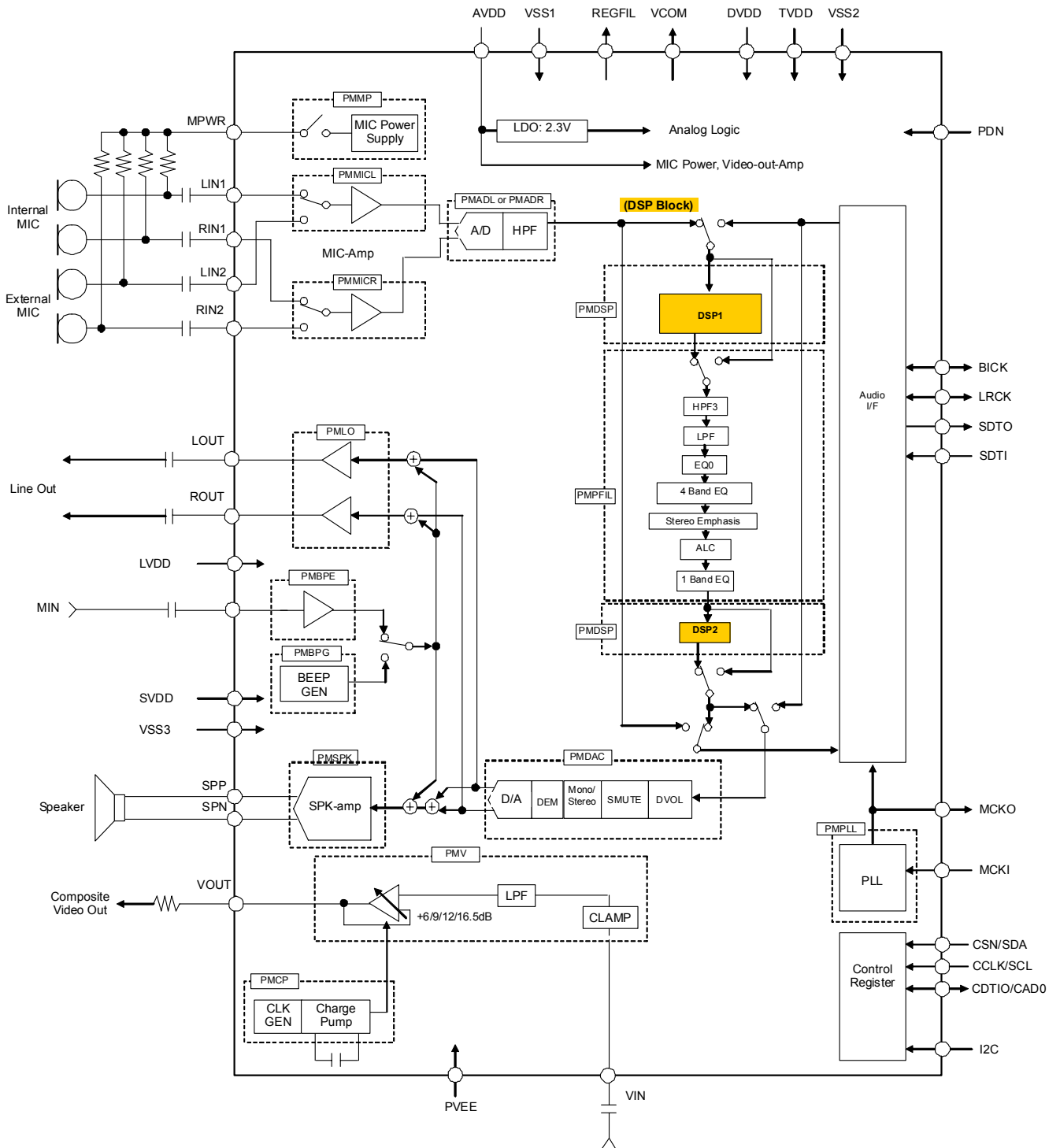

Figure 1. Block Diagram

Total: 36pin

■ **Ordering Guide**

AK4955ECB
AKD4955

-30 ~ +85°C 36pin CSP (0.5mm pitch) Black Type
Evaluation board for AK4955

■ **Pin Layout**

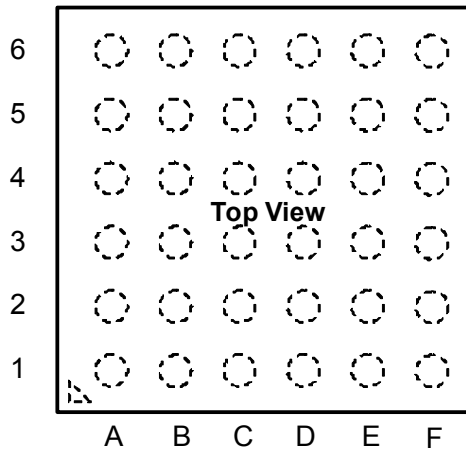

6	MCKI	SDTI	RIN1	LIN1	SVDD	SPN
5	BICK	LRCK	ROUT	LVDD	SPP	VSS3
4	VSS2	DVDD	LOUT	RIN2	VSS1	VCOM
3	SDTO	TVDD	MIN	LIN2	MPWR	REGFIL
2	MCKO	CDTIO /CAD0	VOUT	I2C	AVDD	VSS1
1	CCLK /SCL	CSN /SDA	PDN	VIN	VSS1	PVEE
	A	B	C	D	E	F

Top View

PIN/FUNCTION			
No	Pin Name	I/O	Function
Power Supply			
E2	AVDD	-	Analog Power Supply Pin, 2.7 ~ 3.6V
D5	LVDD		Lineout-Amp Power Supply Pin, 2.7 ~ 5.5V
F4	VCOM	O	Common Voltage Output Pin Bias voltage of ADC inputs and DAC outputs.
E1	VSS1	-	Ground 1 Pin
E4			
F2			
B4	DVDD	-	Digital Power Supply Pin, 1.6 ~ 2.0V
B3	TVDD	-	Digital Interface Supply Pin, DVDD-0.2 ~ 3.6V
F3	REGFIL	-	LDO Voltage Output pin for Analog Logic (typ 2.3V) This pin must be connected to VSS1 with 2.2 μ F \pm 50% capacitor in series.
A4	VSS2	-	Ground 2 Pin
E6	SVDD	-	Speaker-Amp Power Supply Pin, 2.7 ~ 5.5V
F5	VSS3	-	Ground 3 Pin
F1	PVEE	O	Negative Charge Pump Output Pin Connect to VSS1 with a 2.2 μ F capacitor which is low ESR (Equivalent Series Resistance) over all temperature range.
Audio Interface			
A6	MCKI	I	Master Clock Input Pin (Note 1)
A2	MCKO	O	Master Clock Output Pin
B5	LRCK	I/O	Channel Clock Pin (Note 1)
A5	BICK	I/O	Audio Serial Data Clock Pin (Note 1)
B6	SDTI	I	Audio Serial Data Input Pin (Note 1)
A3	SDTO	O	Audio Serial Data Output Pin
Control Register Interface			
B1	CSN	I	Chip Select Pin (I2C pin = "L") (Note 1)
	SDA	I/O	Control Data Input/Output Pin (I2C pin = "H") (Note 1)
A1	CCLK	I	Control Data Clock Pin (I2C pin = "L") (Note 1)
	SCL	I	Control Data Clock Pin (I2C pin = "H") (Note 1)
B2	CDTIO	I/O	Control Data Input/Output Pin (I2C pin = "L") (Note 1)
	CAD0	I	Chip Address Select Pin (I2C pin = "H") (Note 1)
D2	I2C	I	Control Mode Select Pin "H": I ² C Bus, "L": 3-wire Serial (Note 1)

No	Pin Name	I/O	Function
MIC Block			
D6	LIN1	I	Lch Analog Input Line Input 1Pin (DMIC bit = "0")
	DMDAT	I	Digital Microphone Data Input Pin (DMIC bit = "1") (Note 1)
C6	RIN1	I	Rch Analog Input 1 Pin (DMIC bit = "0")
	DMCLK	O	Digital Microphone Clock pin (DMIC bit = "1")
D3	LIN2	I	Lch Analog Input 2 pin
D4	RIN2	I	Rch Analog Input 2 Pin
E3	MPWR	O	MIC Power Supply Pin for Microphone
MIN Block			
C3	MIN	I	Mono Analog Signal Input Pin
Lineout Block			
C4	LOUT	O	Lch Analog Output Pin
C5	ROUT	O	Rch Analog Output Pin
Speaker Block			
E5	SPP	O	Speaker Amp Positive Output Pin
F6	SPN	O	Speaker Amp Negative Output Pin
Video Block			
D1	VIN	I	Composite Video Input Pin
C2	VOUT	O	Composite Video Output Pin
Other Functions			
C1	PDN	I	Reset & Power-down Pin (Note 1) "L": Reset & Power-down, "H": Normal Operation

Note 1. All input pins except analog input pins (MIN, LIN1, RIN1, LIN2, RIN2, VIN) must not be allowed to float.

■ Handling of Unused Pin

Unused I/O pins must be processed appropriately as below.

Classification	Pin Name	Setting
Analog	MPWR, SPN, SPP, LOUT, ROUT, MIN, RIN2, LIN2, LIN1/DMDAT, RIN1/DMCLK, VIN, VOUT	These pins must be open.
Digital	MCKO, SDTO	These pins must be open.
	MCKI, SDTI	These pins must be connected to VSS2.
	LRCK, BICK	M/S bit = "0", these pins must be connected to VSS2.

ABSOLUTE MAXIMUM RATINGS

(VSS1=VSS2=VSS3= 0V; Note 2)

Parameter	Symbol	min	max	Unit	
Power Supplies:	Analog	AVDD	-0.3	6.0	V
	Digital	DVDD	-0.3	2.5	V
	Lineout-Amp	LVDD	-0.3	6.0	V
	Speaker-Amp	SVDD	-0.3	6.0	V
	Digital I/O	TVDD	-0.3	6.0	V
Input Current, Any Pin Except Supplies	IIN	-	±10	mA	
Analog Input Voltage (Note 4)	VINA	-0.3	AVDD+0.3	V	
Digital Input Voltage	(Note 5)	VIND	-0.3	TVDD+0.3	V
	(Note 7)	VIND	-0.3	6.0	V
Ambient Temperature (powered applied)	Ta	-30	85	°C	
Storage Temperature	Tstg	-65	150	°C	
Maximum Power Dissipation (Note 7)	Pd1	-	880	mW	

Note 2. All voltages are with respect to ground.

Note 3. VSS1, VSS2 and VSS3 must be connected to the same analog ground plane.

Note 4. MIN, LIN1, RIN1, LIN2, RIN2, VIN pins

Note 5. PDN, CDTIO/CAD0, SDTI, LRCK, BICK, MCKI and I2C pins

Note 6. CSN/SDA and CCLK/SCL pins

Note 7. This power is the AK4955 internal dissipation that does not include power dissipation of externally connected speakers. The maximum junction temperature is 125°C and θ_{ja} (Junction to Ambient) is 35°C/W at JESD51-9 (2p2s). When $P_d = 880\text{mW}$ and the θ_{ja} is 35°C/W, the junction temperature does not exceed 125°C. In this case, there is no case that the AK4955 is damaged by its internal power dissipation. Therefore, the AK4955 should be used in the condition of $\theta_{ja} \leq 35^\circ\text{C/W}$.

WARNING: Operation at or beyond these limits may result in permanent damage to the device.
Normal operation is not guaranteed at these extremes.

RECOMMENDED OPERATING CONDITIONS

(VSS1=VSS2=VSS3= 0V; Note 2)

Parameter	Symbol	min	typ	max	Unit	
Power Supplies (Note 8)	Analog	AVDD	2.7	3.3	3.6	V
	Digital	DVDD	1.6	1.8	2.0	V
	Lineout-Amp	LVDD	2.7	3.3	5.5	V
	Speaker-Amp	SVDD	2.7	3.3	5.5	V
	Digital I/O (Note 9)	TVDD	DVDD-0.2 or 1.6		1.8	3.6

Note 2. All voltages are with respect to ground.

Note 8. The power-up sequence between AVDD, DVDD, TVDD, LVDD and SVDD is not critical. The PDN pin must be "L" upon power up, and should be changed to "H" after all power supplies are supplied to avoid an internal circuit error.

Note 9. The minimum value is higher voltage between (DVDD-0.2)V and 1.6V.

*** When TVDD is powered ON and the PDN pin is "L", AVDD DVDD, LVDD and SVDD can be powered ON/OFF. When the AK4955 is powered ON from power-down state, the PDN pin must be "H" after all power supplies (AVDD, DVDD, TVDD, LVDD and SVDD) are ON.**

* AKM assumes no responsibility for the usage beyond the conditions in this datasheet.

ANALOG CHARACTERISTICS

(Ta=25°C; AVDD=LVDD=SVDD=3.3V, DVDD=TVDD= 1.8V; VSS1=VSS2=VSS3= 0V; fs=48kHz, BICK=64fs; Signal Frequency=1kHz; 24bit Data; Measurement Bandwidth=20Hz ~ 20kHz; unless otherwise specified)

Parameter		min	typ	max	Unit
MIC Amplifier: LIN1, RIN1, LIN2, RIN2 pins					
Input Resistance		23	33	43	kΩ
Gain	MGAIN3-0 bits = "0000"	-1	0	+1	dB
	MGAIN3-0 bits = "0001"	+4	+5	+6	dB
	MGAIN3-0 bits = "0010"	+7	+8	+9	dB
	MGAIN3-0 bits = "0011"	+10	+11	+12	dB
	MGAIN3-0 bits = "0100"	+13	+14	+15	dB
	MGAIN3-0 bits = "0101"	+15	+16	+17	dB
	MGAIN3-0 bits = "0110"	+17	+18	+19	dB
	MGAIN3-0 bits = "0111"	+20	+21	+22	dB
	MGAIN3-0 bits = "1000"	+23	+24	+25	dB
MIC Power Supply: MPWR pin					
Output Voltage	MICL bit = "0"	2.3	2.5	2.7	V
	MICL bit = "1"	2.0	2.2	2.4	V
Output Noise Level (A-weighted)		-	-108	-	dBV
Load Resistance		0.5	-	-	kΩ
Load Capacitance		-	-	30	pF
PSRR (fin = 1kHz)		-	100	-	dB
ADC Analog Input Characteristics					
: LIN1/RIN1/LIN2/RIN2 pins → ADC (Programmable Filter = DSP=OFF)					
Resolution		-	-	24	Bits
Input Voltage (Note 11)	(Note 12)	-	0.261	-	Vpp
	(Note 13)	1.86	2.07	2.28	Vpp
S/(N+D) (-1dBFS)	(Note 12)	71	81	-	dBFS
	(Note 13)	-	82	-	dBFS
D-Range (-60dBFS, A-weighted)	(Note 12)	78	88	-	dB
	(Note 13)	-	96	-	dB
S/N (A-weighted)	(Note 12)	78	88	-	dB
	(Note 13)	-	96	-	dB
Interchannel Isolation	(Note 12)	75	90	-	dB
	(Note 13)	-	100	-	dB
Interchannel Gain Mismatch	(Note 12)	-	0	0.5	dB
	(Note 13)	-	0	0.5	dB

Note 10. MICL bit must be set to "1" when AVDD=2.7 ~ 3.6V, and it must be set to "0" when AVDD=2.9 ~ 3.6V.

Note 11. Vin = 0.9 x 2.3Vpp (typ) @MGAIN3-0 bits = "0000" (0dB)

Note 12. MGAIN3-0 bits = "0110" (+18dB)

Note 13. MGAIN3-0 bits = "0000" (0dB)

Parameter	min	typ	max	Unit	
DAC Characteristics:					
Resolution	-	-	24	Bits	
Stereo Line Output Characteristics: DAC → LOUT, ROUT pins, ALC=OFF, DVOL=OVOL =0dB, $R_L=10k\Omega$, PMBP bit = "0", LVCM1-0 bits = "00"					
Output Voltage	LVCM1-0 bits = "00" (Note 14)	1.94	2.16	2.38	Vpp
	LVCM1-0 bits = "01" (Note 15)	2.27	2.52	2.77	Vpp
	LVCM1-0 bits = "10" (Note 16)	3.02	3.36	3.70	Vpp
	LVCM1-0 bits = "11" (Note 17)	3.40	3.78	4.16	Vpp
S/(N+D) (-3dBFS) (Note 14, Note 15)	75	85	-	dB	
S/N (A-weighted)	82	92	-	dB	
Interchannel Isolation	85	100	-	dB	
Interchannel Gain Mismatch	-	0	0.8	dB	
Load Resistance	10	-	-	k Ω	
Load Capacitance	-	-	30	pF	
PSRR (fin = 1kHz)	-	80	-	dB	
Speaker-Amp Characteristics: DAC → SPP/SPN pins, ALC=OFF, DVOL=OVOL =0dB, $R_L=8\Omega$, BTL					
Output Voltage					
SPKG1-0 bits = "00", -0.5dBFS (Po=150mW)	-	3.18	-	Vpp	
SPKG1-0 bits = "01", -0.5dBFS (Po=250mW)	3.20	4.00	4.80	Vpp	
SPKG1-0 bits = "10", -0.5dBFS (Po=400mW)	-	1.79	-	Vrms	
SPKG1-0 bits = "11" -0.5dBFS (Po=600mW, SVDD = 4.8V)	-	2.19	-	Vrms	
S/(N+D)					
SPKG1-0 bits = "00", -0.5dBFS (Po=150mW)	-	70	-	dB	
SPKG1-0 bits = "01", -0.5dBFS (Po=250mW)	20	60	-	dB	
SPKG1-0 bits = "10", -0.5dBFS (Po=400mW)	-	20	-	dB	
SPKG1-0 bits = "11" -0.5dBFS (Po=600mW, SVDD = 4.8V)	-	20	-	dB	
S/N SPKG1-0 bits = "01", -0.5dBFS (Po=250mW) (A-weighted)	85	95	-	dB	
Load Resistance	6.8	-	-	Ω	
Load Capacitance	-	-	30	pF	
PSRR (fin = 1kHz)	-	60	-	dB	

Note 14. LVDD must be in the range of 2.7V~5.5V when LVCM1-0 bits = "00". The common voltage is typ. 1.30V.

Note 15. LVDD must be in the range of 3.0V~5.5V when LVCM1-0 bits = "01". The common voltage is typ. 1.42V.

Note 16. LVDD must be in the range of 4.0V~5.5V when LVCM1-0 bits = "10". The common voltage is typ. 1.92V.

Note 17. LVDD must be in the range of 4.5V~5.5V when LVCM1-0 bits = "11". The common voltage is typ. 2.10V.

Parameter		min	typ	max	Unit
Mono Input: MIN pin, External Resistance mode (PMBP bit = "1", BPM1-0 bits = "01", BPVCM bit = "0", BPLVL3-0 bits = "0000"), External Input Resistance = 72kΩ					
Maximum Input Voltage (Note 18)		-	-	1.54	V _{pp}
Gain (Note 19)					
MIN → LOUT	LVCM1-0 bits = "00"	-	-1.34	-	dB
	LVCM1-0 bits = "01"	-4.5	0	+4.5	dB
	LVCM1-0 bits = "10"	-	+2.50	-	dB
	LVCM1-0 bits = "11"	-	+3.52	-	dB
MIN → SPP/SPN					
	ALC bit = "0", SPKG1-0 bits = "00"	+1.6	+6.1	+10.6	dB
	ALC bit = "0", SPKG1-0 bits = "01"	-	+8.1	-	dB
	ALC bit = "0", SPKG1-0 bits = "10"	-	+10.1	-	dB
	ALC bit = "0", SPKG1-0 bits = "11"	-	+12.1	-	dB
	ALC bit = "1", SPKG1-0 bits = "00"	-	+8.1	-	dB
	ALC bit = "1", SPKG1-0 bits = "01"	-	+10.1	-	dB
	ALC bit = "1", SPKG1-0 bits = "10"	-	+12.1	-	dB
	ALC bit = "1", SPKG1-0 bits = "11"	-	+14.1	-	dB
Mono Input: MIN pin, Internal Resistance Mode (PMBP bit = "1", BPM1-0 bits = "00", BPVCM bit = "0", BPLVL3-0 bits = "0000")					
Input Resistance		50	72	94	kΩ
Maximum Input Voltage (Note 18)		-	-	1.54	V _{pp}
Gain					
MIN → LOUT	LVCM1-0 bits = "00"	-	-1.34	-	dB
	LVCM1-0 bits = "01"	-1.0	0	+1.0	dB
	LVCM1-0 bits = "10"	-	+2.50	-	dB
	LVCM1-0 bits = "11"	-	+3.52	-	dB
MIN → SPP/SPN					
	ALC bit = "0", SPKG1-0 bits = "00"	+4.1	+6.1	+8.1	dB
	ALC bit = "0", SPKG1-0 bits = "01"	-	+8.1	-	dB
	ALC bit = "0", SPKG1-0 bits = "10"	-	+10.1	-	dB
	ALC bit = "0", SPKG1-0 bits = "11"	-	+12.1	-	dB
	ALC bit = "1", SPKG1-0 bits = "00"	-	+8.1	-	dB
	ALC bit = "1", SPKG1-0 bits = "01"	-	+10.1	-	dB
	ALC bit = "1", SPKG1-0 bits = "10"	-	+12.1	-	dB
	ALC bit = "1", SPKG1-0 bits = "11"	-	+14.1	-	dB

Note 18. The maximum value is AVDD V_{pp} when BPVCM bit = "1". However, it must be set as the amplitude after MIN-Amp is less than 0.1V_{pp}. (set by BPLVL3-0 bits)

Note 19. The gain is in inverse proportion to external input resistance.

Parameter		min	typ	max	Unit
Video Signal Input					
External Resistor (Note 21)	R1 (Figure 2)	-	-	600	Ω
External Capacitor	C1 (Figure 2)	0.05	0.1	0.2	μF
Maximum Input Voltage: VG1-0 bits = "00" (+6dB)					
Pull Down Current		-	0.5	-	μA
Video Analog Output (Figure 3)					
Output Gain fin =100kHz Sine wave Input (Note 20)	VG1-0 bits = "00", 1.0Vpp Input	5.5	6.0	6.5	dB
	VG1-0 bits = "01", 0.7Vpp Input	8.5	9.0	9.5	
	VG1-0 bits = "10", 0.5Vpp Input	11.5	12.0	12.5	
	VG1-0 bits = "11", 0.3Vpp Input	16	16.5	17	
DC Output Offset Level (Note 20)	Signal Input (Pedestal Level)	-100	0	100	mV
	No Signal Input	-	-572	-	mV
S/N (Note 22) VG1-0 bits = "00"(+6dB)	BW = 100kHz ~ 6MHz, S = 0.7Vpp Input	60	70	-	dB
Maximum Output Voltage (Note 20)	fin =100kHz (Sine wave)	2.62	-	-	Vpp
Secondary Harmonic Distortion VG1-0 bits = "00"(+6dB), fin = 3.58MHz, 1.0Vpp: -40 ~ 100IRE, Sine Wave Input					
		-	-40	-30	dB
Load Resistance		140	150	-	Ω
Load Capacitance	C2 (Figure 3)	-	-	15	pF
	C3 (Figure 3)	-	-	400	pF
PSRR VG1-0 bits = "00"(+6dB)	fin = 10kHz	-	58	-	dB
	fin = 100kHz	-	53	-	dB
LPF for VIN signal : (Note 20)					
Frequency Response (fin = 100kHz, 1.0Vpp, Sine wave Input)					
Response at 6.75MHz		-3.0	-0.5	+2.0	dB
Response at 27MHz		-	-40	-20	
Group Delay	GD3MHz-GD6MHz	-	15	100	ns

Note 20. This is a value at measurement point in Figure 3. 1.0Vpp input is the value when VG1-0 bits = "00". Input amplitude is in inverse proportion to the gain. S/N is measured at measuring point 2.

Note 21. PMV bit must be set to "0" if the input impedance of the VIN pin exceeds 600Ω in case of the input signal is stopped or the input circuit of the VIN pin is powered down.

Note 22. S/N = 20xlog (Output Voltage[Vpp]/Noise Level[Vrms]). Output Voltage = 0.7 [Vpp].

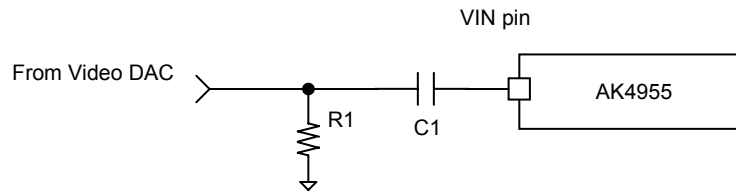

Figure 2. External Resistor of Video Signal Input pin

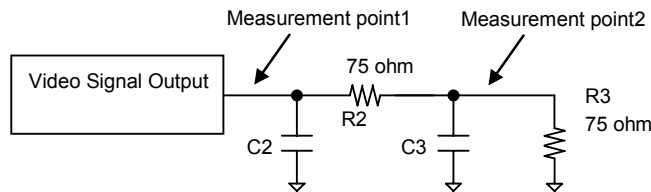

Figure 3. Load Capacitance C2 and C3

Parameter	min	typ	max	Unit
Power Supplies:				
Power Up (PDN pin = "H")				
All Circuit Power-up (Note 23)				
AVDD	-	13.8	21	mA
LVDD + SVDD	-	1.3	2.0	mA
DVDD + TVDD	-	7.1	10.7	mA
MIC + ADC (Note 24)				
AVDD	-	2.9	-	mA
DVDD + TVDD	-	1.3	-	mA
DAC + Lineout (Note 25)				
AVDD	-	1.7	-	mA
LVDD		0.3		
DVDD + TVDD	-	1.0	-	mA
DAC + SPK-Amp (Note 26)				
AVDD	-	1.5	-	mA
SVDD		1.0		
DVDD + TVDD	-	1.0	-	mA
Video Block (Note 27)				
AVDD	-	10.5	-	mA
Power Down (PDN pin = "L") (Note 28)				
ALL VDD	-	1	5	μA

Note 23. PMADL=PMADR=PMDAC=PMPFIL=PMDSP=PMLO=PMSPK=PMPLL=MCKO=PMBP=PMMP
=PMMICR =PMMICL =M/S =PMV =PMCP bits = "1", SPK-amp No load, black signal is input to the VIN pin.
In this case, the output current of the MPWR pin is 0mA. The sampling frequency is 48kHz. 1kHz signal with 1.845Vpp amplitude is input to LIN and 1.2kHz signal with 1.845Vpp amplitude is input to RIN while the data path setting is DSPBP=PFDAC=ADCDO bits = "1". Noise canceling program is run by the DSP.

Note 24. In EXT Slave Mode (PMPLL=M/S=MCKO bits = "0"), PMADL = PMADR = PMMICL = PMMICLR bits = "1", and PMDSP bit = "0".

Note 25. In EXT Slave Mode (PMPLL=M/S=MCKO bits = "0"), PMDAC = PMLO bits = "1", and PMDSP bit = "0".

Note 26. In EXT Slave Mode (PMPLL=M/S=MCKO bits = "0"), PMDAC = PMSPK = SPPSN bits = "1", and PMDSP bit = "0" with No load at the SPK-Amp.

Note 27. PMV =PMCP bits = "1", No load, and the black signal is only input to the VIN pin.

Note 28. All digital input pins are fixed to TVDD or VSS2.

FILTER CHARACTERISTICS

(Ta =25°C; AVDD=2.7 ~ 3.6V, DVDD = 1.6 ~ 2.0V, LVDD = 2.7 ~ 5.5V, SVDD= 2.7 ~ 5.5V, TVDD = DVDD-0.2 ~ 3.6V; fs=48kHz, DEM= OFF)

Parameter		Symbol	min	typ	max	Unit
ADC Digital Filter (Decimation LPF):						
Passband (Note 29)	±0.16dB	PB	0	-	18.8	kHz
	-0.66dB		-	21.1	-	kHz
	-1.1dB		-	21.7	-	kHz
	-6.9dB		-	24.1	-	kHz
Stopband (Note 29)		SB	28.4	-	-	kHz
Passband Ripple		PR	-	-	±0.16	dB
Stopband Attenuation		SA	73	-	-	dB
Group Delay (Note 30)		GD	-	16	-	1/fs
Group Delay Distortion		ΔGD	-	0	-	μs
ADC Digital Filter (HPF): HPFC1-0 bits = "00"						
Frequency Response (Note 29)	-3.0dB	FR	-	3.7	-	Hz
	-0.5dB		-	10.9	-	Hz
	-0.1dB		-	23.9	-	Hz
DAC Digital Filter (LPF):						
Passband (Note 29)	±0.05dB	PB	0	-	21.8	kHz
	-6.0dB		-	24	-	kHz
Stopband (Note 29)		SB	26.2	-	-	kHz
Passband Ripple		PR	-	-	±0.05	dB
Stopband Attenuation		SA	54	-	-	dB
Group Delay (Note 30)		GD	-	22	-	1/fs
DAC Digital Filter (LPF) + SCF:						
Frequency Response: 0 ~ 20.0kHz		FR	-	±1.0	-	dB

Note 29. The passband and stopband frequencies scale with fs (system sampling rate). Each response refers to that of 1kHz. For example, it is 0.454 x fs (ADC) when PB=21.7kHz (@-1.1dB).

Note 30. A calculating delay time which is induced by digital filtering. This time is from the input of an analog signal to the setting of 24-bit data of both channels to the ADC output register. For the DAC, this time is from setting the 24-bit data of a channel from the input register to the output of analog signal. For the signal through the block controlled by PMPFIL bit, the group delay is increased by 4/fs (typ) at ADC block, by 7/fs (typ) at DAC block from the value above in both recording and playback modes if there is no phase change by the IIR filter. The group delay is increased more for the signal through the block controlled by PMDSP bit.

DC CHARACTERISTICS

(Ta =25°C; AVDD = 2.7 ~ 3.6V, DVDD = 1.6 ~ 2.0V, LVDD = 2.7 ~ 5.5V, SVDD= 2.7 ~ 5.5V, TVDD =DVDD-0.2 ~ 3.6V; fs= 48kHz; DEM=OFF)

Parameter	Symbol	min	typ	max	Unit
Audio Interface & Serial μP Interface (CDTIO/CAD0, CSN/SDA, CCLK/SCL, I2C, PDN, BICK, LRCK, SDTI, MCKI pins)					
High-Level Input Voltage (TVDD \geq 2.2V)	V _{IH}	70%TVDD	-	-	V
(TVDD < 2.2V)	V _{IH}	80%TVDD	-	-	V
Low-Level Input Voltage (TVDD \geq 2.2V)	V _{IL}	-	-	30%TVDD	V
(TVDD < 2.2V)	V _{IL}	-	-	20%TVDD	V
Audio Interface & Serial μP Interface (CDTIO, SDA MCKO, BICK, LRCK, SDTO pins Output)					
High-Level Output Voltage (I _{out} = -80 μ A)	V _{OH}	TVDD-0.2	-	-	V
Low-Level Output Voltage (Except SDA pin : I _{out} = 80 μ A)	V _{OL1}	-	-	0.2	V
(SDA pin, 2.0V \leq TVDD \leq 3.6V: I _{out} = 3mA)	V _{OL2}	-	-	0.4	V
(SDA pin, 1.6V \leq TVDD < 2.0V: I _{out} = 3mA)	V _{OL2}	-	-	20%TVDD	V
Input Leakage Current	I _{in1}	-	-	\pm 10	μ A
Digital MIC Interface (DMDAT pin Input ; DMIC bit = "1")					
High-Level Input Voltage	V _{IH2}	65%AVDD	-	-	V
Low-Level Input Voltage	V _{IL2}	-	-	35%AVDD	V
Input Leakage Current	I _{in2}	-	-	\pm 10	μ A
Digital MIC Interface (DMCLK pin Output ; DMIC bit = "1")					
High-Level Output Voltage (I _{out} =-80 μ A)	V _{OH3}	AVDD-0.4	-	-	V
Low-Level Output Voltage (I _{out} = 80 μ A)	V _{OL3}	-	-	0.4	V

SWITCHING CHARACTERISTICS

(Ta = 25°C; AVDD = 2.7 ~ 3.6V, DVDD = 1.6 ~ 2.0V, LVDD = 2.7~5.5V, SVDD = 2.7~5.5V, TVDD = DVDD-0.2~3.6V; CL = 20pF)

Parameter	Symbol	min	typ	max	Unit
PLL Master Mode (PLL Reference Clock = MCKI pin)					
MCKI Input Timing					
Frequency	fCLK	11.2896	-	27	MHz
Pulse Width Low	tCLKL	0.4/fCLK	-	-	ns
Pulse Width High	tCLKH	0.4/fCLK	-	-	ns
MCKO Output Timing					
Frequency	fMCK	0.256	-	12.288	MHz
Duty Cycle	dMCK	40	50	60	%
LRCK Output Timing					
Frequency	fs	8	-	48	kHz
Duty Cycle	Duty	-	50	-	%
BICK Output Timing					
Period	BCKO bit = "0"	tBCK	-	1/(32fs)	ns
	BCKO bit = "1"	tBCK	-	1/(64fs)	ns
Duty Cycle	dBCK	-	50	-	%
PLL Slave Mode (PLL Reference Clock = MCKI pin)					
MCKI Input Timing					
Frequency	fCLK	11.2896	-	27	MHz
Pulse Width Low	tCLKL	0.4/fCLK	-	-	ns
Pulse Width High	tCLKH	0.4/fCLK	-	-	ns
MCKO Output Timing					
Frequency	fMCK	0.256	-	12.288	MHz
Duty Cycle	dMCK	40	50	60	%
LRCK Input Timing					
Frequency	fs	8	-	48	kHz
Duty	Duty	45	-	55	%
BICK Input Timing					
Period	tBCK	1/(64fs)	-	1/(32fs)	ns
Pulse Width Low	tBCKL	0.4 x tBCK	-	-	ns
Pulse Width High	tBCKH	0.4 x tBCK	-	-	ns

Parameter	Symbol	min	typ	max	Unit	
PLL Slave Mode (PLL Reference Clock = BICK pin)						
LRCK Input Timing						
Frequency	fs	7.35	-	48	kHz	
Duty	Duty	45	-	55	%	
BICK Input Timing						
Period	PLL3-0 bits = "0010"	tBCK	-	1/(32fs)	-	ns
	PLL3-0 bits = "0011"	tBCK	-	1/(64fs)	-	ns
Pulse Width Low		tBCKL	0.4 x tBCK	-	-	ns
Pulse Width High		tBCKH	0.4 x tBCK	-	-	ns
External Slave Mode						
MCKI Input Timing						
Frequency	256fs	fCLK	1.8816	-	12.288	MHz
	512fs	fCLK	3.7632	-	24.576	MHz
	1024fs	fCLK	7.5264	-	13.312	MHz
Pulse Width Low		tCLKL	0.4/fCLK	-	-	ns
Pulse Width High		tCLKH	0.4/fCLK	-	-	ns
LRCK Input Timing						
Frequency	256fs	fs	7.35	-	48	kHz
	512fs	fs	7.35	-	48	kHz
	1024fs	fs	7.35	-	13	kHz
Duty	Duty	45	-	55	%	
BICK Input Timing						
Period		tBCK	312.5	-	-	ns
Pulse Width Low		tBCKL	130	-	-	ns
Pulse Width High		tBCKH	130	-	-	ns
External Master Mode						
MCKI Input Timing						
Frequency	256fs	fCLK	1.8816	-	12.288	MHz
	512fs	fCLK	3.7632	-	24.576	MHz
	1024fs	fCLK	7.5264	-	13.312	MHz
Pulse Width Low		tCLKL	0.4/fCLK	-	-	ns
Pulse Width High		tCLKH	0.4/fCLK	-	-	ns
LRCK Output Timing						
Frequency		fs	7.35	-	48	kHz
Duty Cycle		Duty	-	50	-	%
BICK Output Timing						
Period	BCKO bit = "0"	tBCK	-	1/(32fs)	-	ns
	BCKO bit = "1"	tBCK	-	1/(64fs)	-	ns
Duty Cycle		dBCK	-	50	-	%

Parameter	Symbol	min	typ	max	Unit
Audio Interface Timing					
Master Mode					
BICK “↓” to LRCK Edge (Note 31)	tMBLR	-40	-	40	ns
LRCK Edge to SDTO (MSB) (Except I ² S mode)	tLRD	-70	-	70	ns
BICK “↓” to SDTO	tBSD	-70	-	70	ns
SDTI Hold Time	tSDH	50	-	-	ns
SDTI Setup Time	tSDS	50	-	-	ns
Slave Mode					
LRCK Edge to BICK “↑” (Note 31)	tLRB	50	-	-	ns
BICK “↑” to LRCK Edge (Note 31)	tBLR	50	-	-	ns
LRCK Edge to SDTO (MSB) (Except I ² S mode)	tLRD	-	-	80	ns
BICK “↓” to SDTO	tBSD	-	-	80	ns
SDTI Hold Time	tSDH	50	-	-	ns
SDTI Setup Time	tSDS	50	-	-	ns
Control Interface Timing (3-wire Mode) (Note 32)					
CCLK Period	tCCK	80	-	-	ns
CCLK Pulse Width Low	tCCKL	32	-	-	ns
Pulse Width High	tCCKH	32	-	-	ns
CDTIO Setup Time	tCDS	16	-	-	ns
CDTIO Hold Time	tCDH	16	-	-	ns
CSN “H” Time	tCSW	60	-	-	ns
CSN Edge to CCLK “↑” (Note 33)	tCSS	20	-	-	ns
CCLK “↑” to CSN Edge (Note 33)	tCSH	20	-	-	ns
CCLK “↓” to CDTIO (at Read Command)	tDCD	-	-	70	ns
CSN “↑” to CDTIO (Hi-Z) (at Read Command)(Note 35)	tCCZ	-	-	70	ns
Control Interface Timing (I²C Bus Mode):					
SCL Clock Frequency	fSCL	-	-	400	kHz
Bus Free Time Between Transmissions	tBUF	1.3	-	-	μs
Start Condition Hold Time (prior to first clock pulse)	tHD:STA	0.6	-	-	μs
Clock Low Time	tLOW	1.3	-	-	μs
Clock High Time	tHIGH	0.6	-	-	μs
Setup Time for Repeated Start Condition	tSU:STA	0.6	-	-	μs
SDA Hold Time from SCL Falling (Note 36)	tHD:DAT	0	-	-	μs
SDA Setup Time from SCL Rising	tSU:DAT	0.1	-	-	μs
Rise Time of Both SDA and SCL Lines	tR	-	-	0.3	μs
Fall Time of Both SDA and SCL Lines	tF	-	-	0.3	μs
Setup Time for Stop Condition	tSU:STO	0.6	-	-	μs
Capacitive Load on Bus	Cb	-	-	400	pF
Pulse Width of Spike Noise Suppressed by Input Filter	tSP	0	-	50	ns

Note 31. BICK rising edge must not occur at the same time as LRCK edge.

Note 32. When accessing to CODEC registers, the maximum frequency of CCLK for write operation is 12.5MHz and 6.75MHz for read operation, regardless of the operating frequency of the internal DSP. When accessing to the DSP, CCLK and CDTI interface timings are changed depending on the operating frequency of the internal DSP. For example, the DSP operating frequency (256times of the sampling frequency) is 12.288MHz, CCLK and CDTI timings are multiplied by 12.5/12.288. (except tDCD and tCCZ) Then, the maximum frequency of CCLK is 12.288MHz. (when DSP operating frequency = 12.288MHz)

Note 33. CCLK rising edge must not occur at the same time as CSN edge.

Note 34. I²C-bus is a trademark of NXP B.V.

Note 35. It is the time of 10% potential change of the CDTIO pin when R_L=1kΩ (pull-up to TVDD).

Note 36. Data must be held for sufficient time to bridge the 300 ns transition time of SCL.

Parameter	Symbol	min	typ	max	Unit
Digital Audio Interface Timing; C_L=100pF					
DMCLK Output Timing					
Period	tSCK	-	1/(64fs)	-	ns
Rising Time	tSRise	-	-	10	ns
Falling Time	tSfall	-	-	10	ns
Duty Cycle	dSCK	40	50	60	%
Audio Interface Timing					
DMDAT Setup Time	tDSDS	50	-	-	ns
DMDAT Hold Time	tDSDH	0	-	-	ns
Power-down & Reset Timing					
PDN Accept Pulse Width (Note 37)	tAPD	180	-	-	ns
PDN Reject Pulse Width (Note 37)	tRPD	-	-	50	ns
PMADL or PMADR “↑” to SDTO valid (Note 38)					
ADRST1-0 bits =“00”	tPDV	-	1059	-	1/fs
ADRST1-0 bits =“01”	tPDV	-	267	-	1/fs
ADRST1-0 bits =“10”	tPDV	-	531	-	1/fs
ADRST1-0 bits =“11”	tPDV	-	135	-	1/fs

Note 37. The AK4955 can be reset by the PDN pin = “L”. The PDN pin must held “L” for more than 180ns for a certain reset. The AK4955 is not reset by the “L” pulse less than 50ns.

Note 38. This is the count of LRCK “↑” from the PMADL or PMADR bit = “1”.

■ Timing Diagram

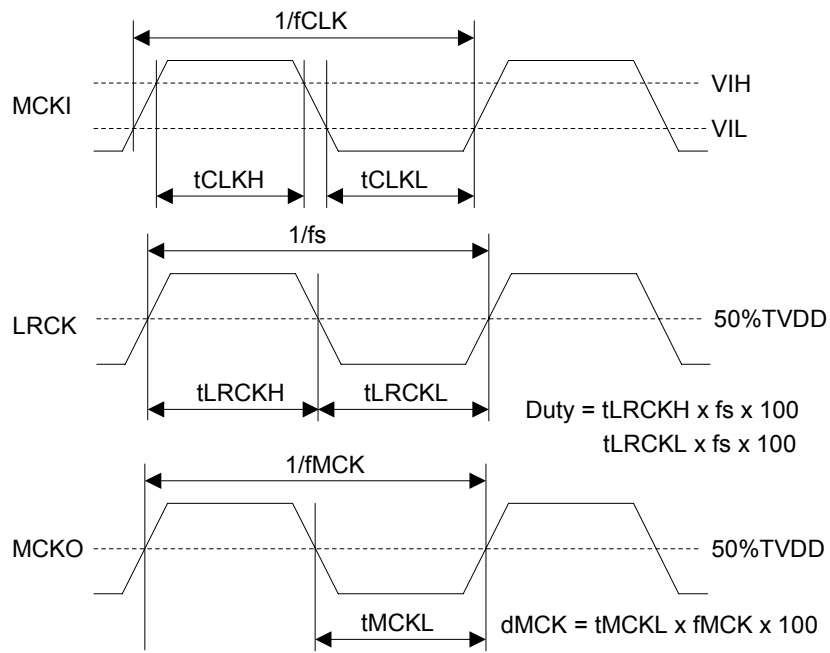

Note 39. MCKO is not available at EXT Master mode.
 Figure 4. Clock Timing (PLL/EXT Master mode)

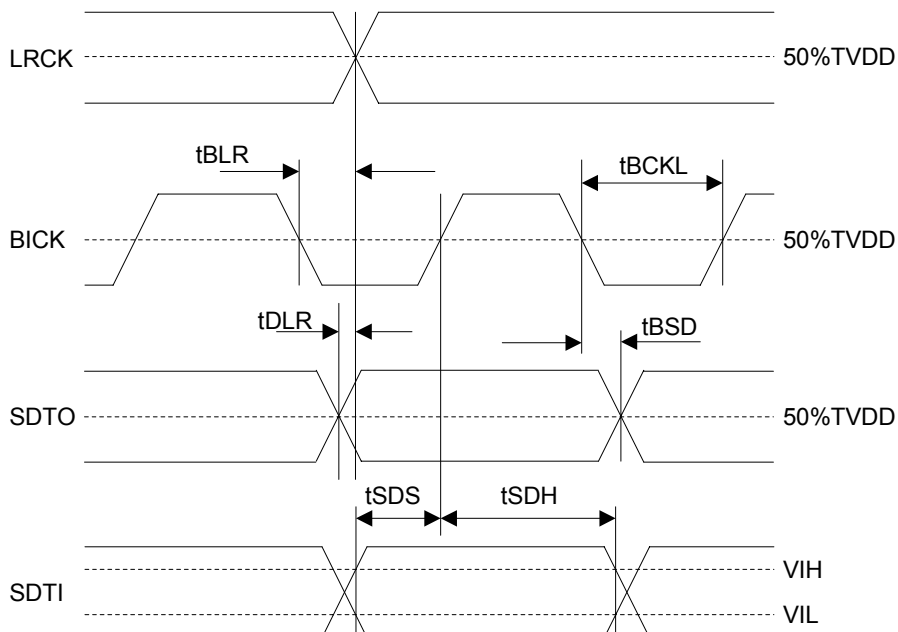

Figure 5. Audio Interface Timing (PLL/EXT Master mode)

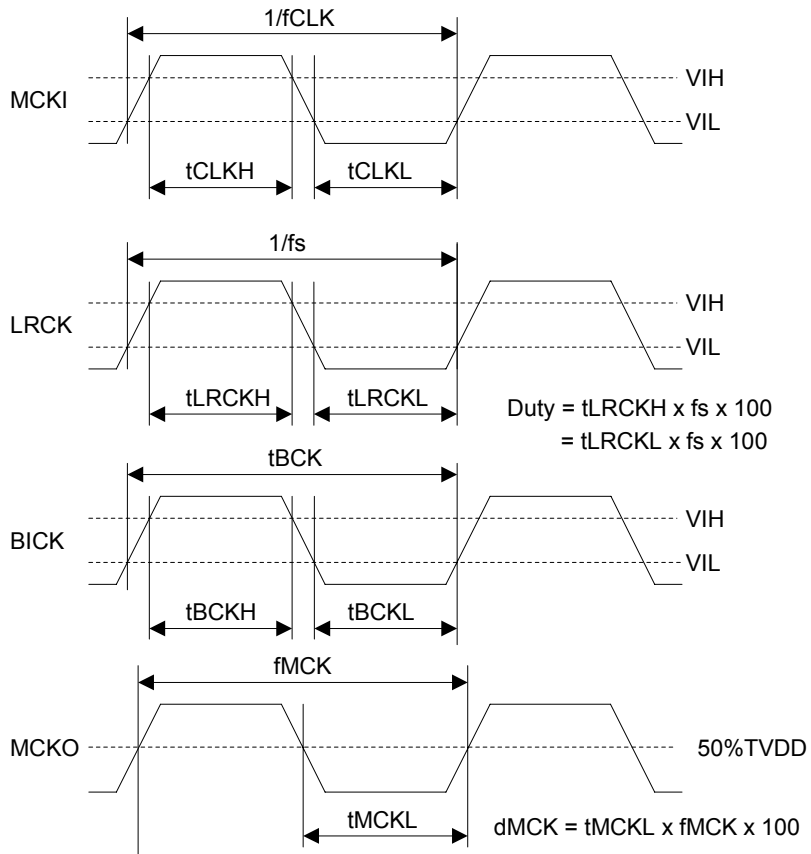

Figure 6. Clock Timing (PLL Slave mode; PLL Reference Clock = MCKI pin)

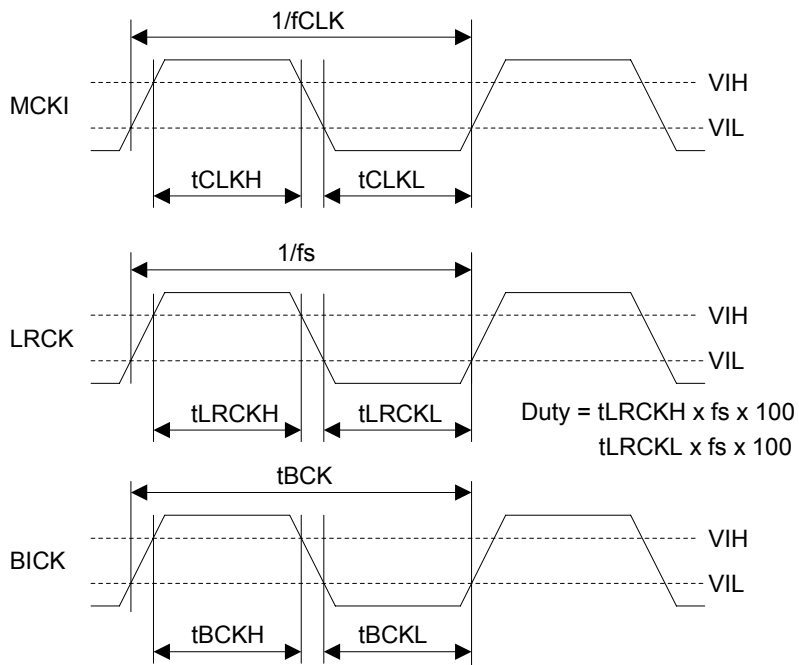

Figure 7. Clock Timing (EXT Slave mode)

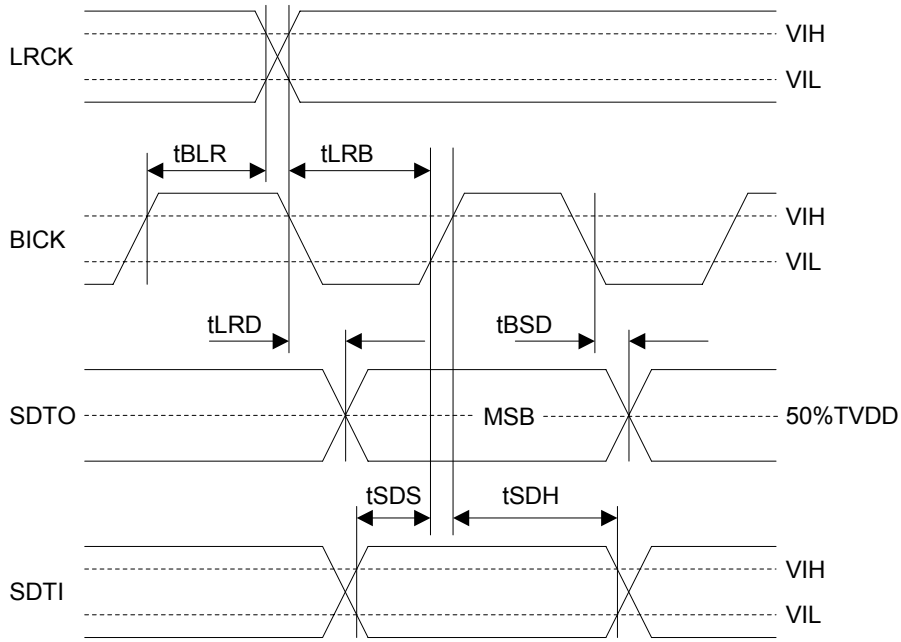

Figure 8. Audio Interface Timing (PLL/EXT Slave mode)

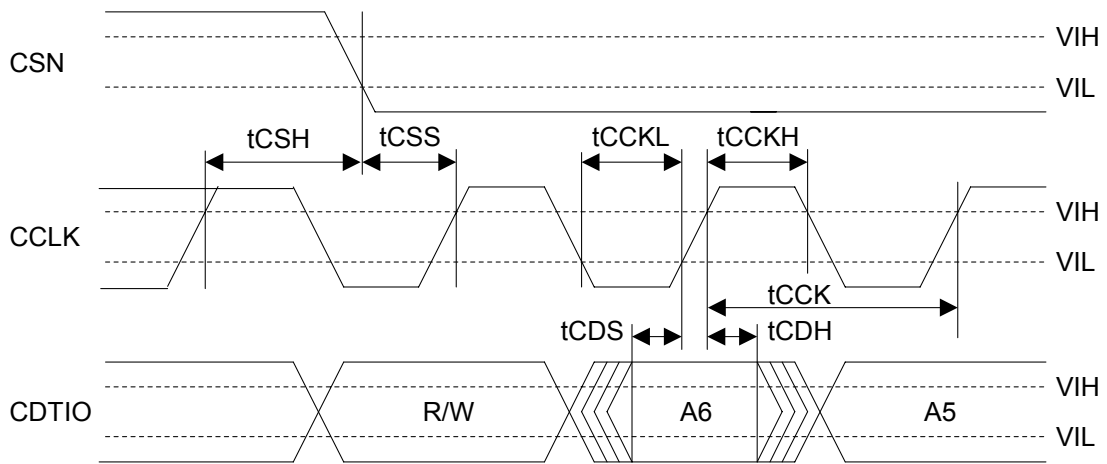

Figure 9. WRITE Command Input Timing

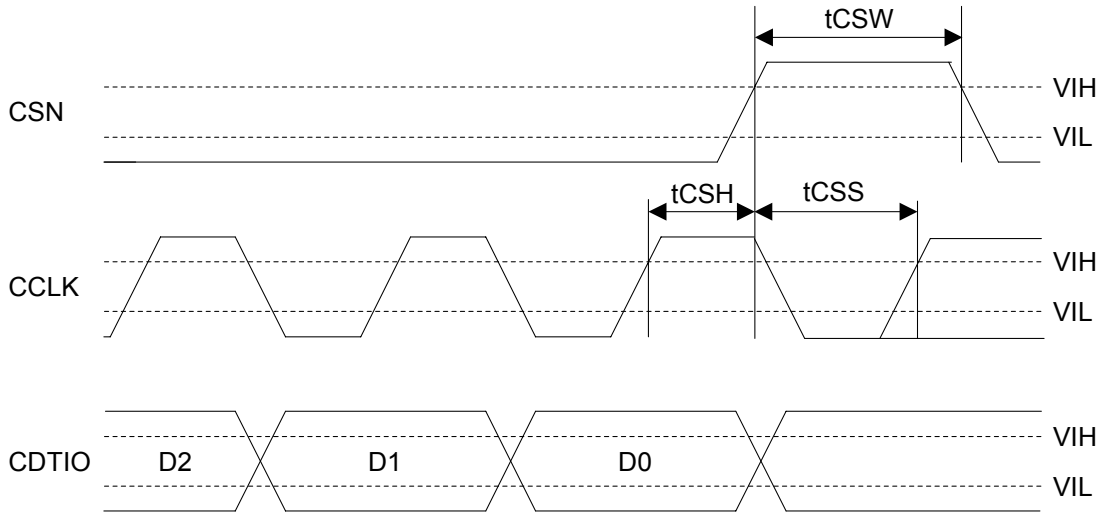

Figure 10. WRITE Data Input Timing

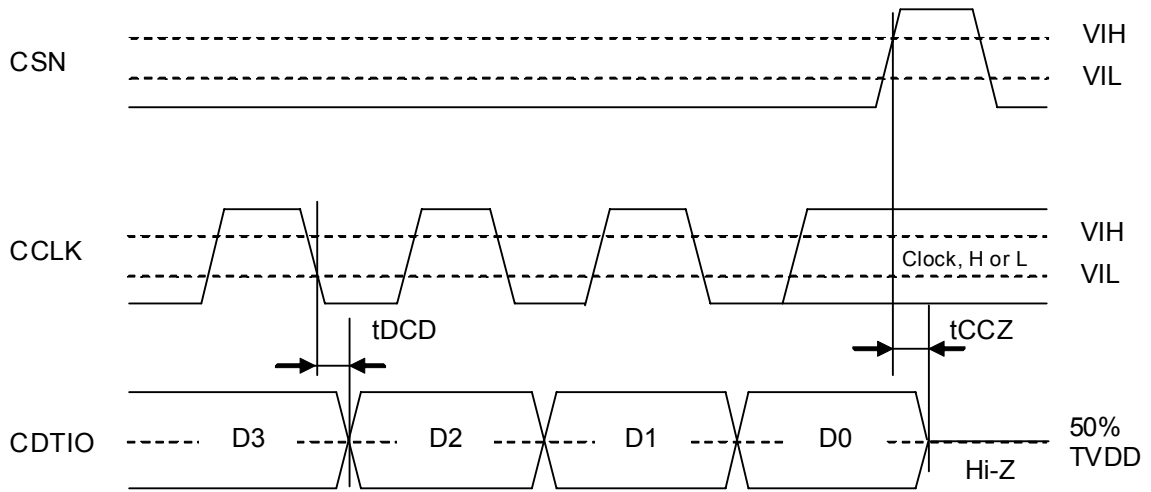

Figure 11. Read Data Output Timing

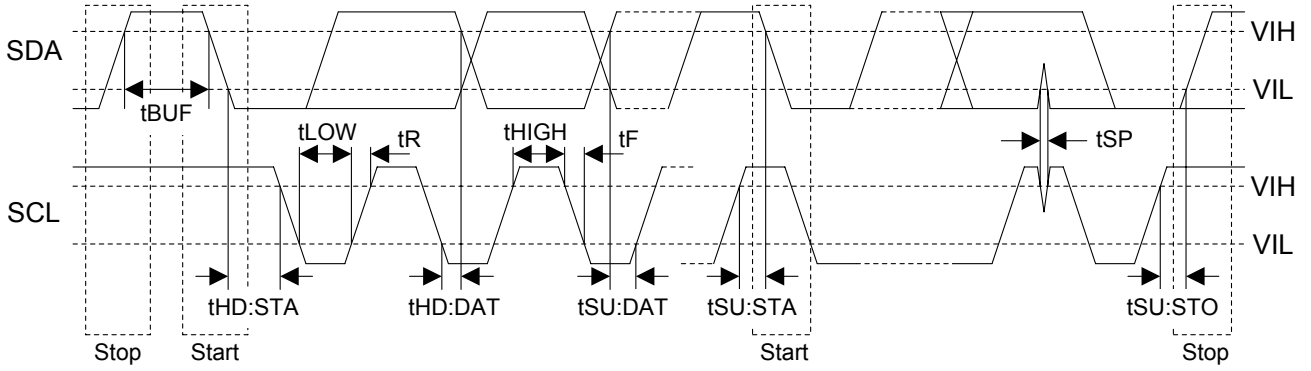
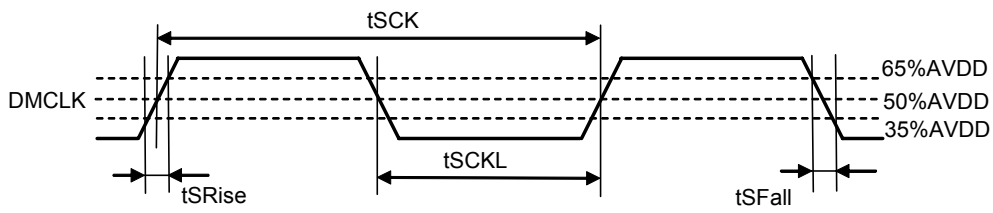

Figure 12. I²C Bus Mode Timing



$$dSCK = 100 \times t_{SCKL} / t_{SCK}$$

Figure 13. DMCLK Clock Timing

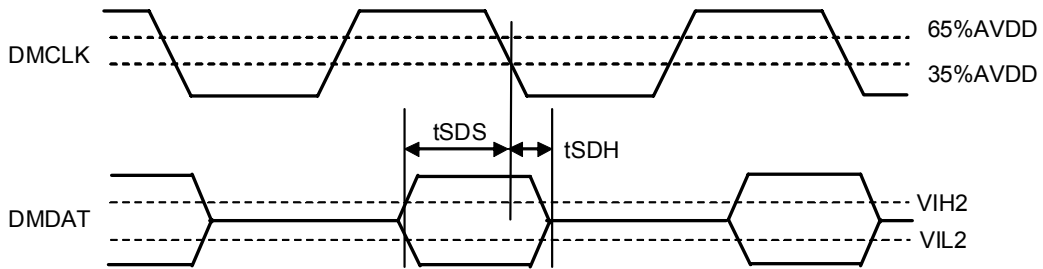

Figure 14. Audio Interface Timing (DCLKP bit = "1")

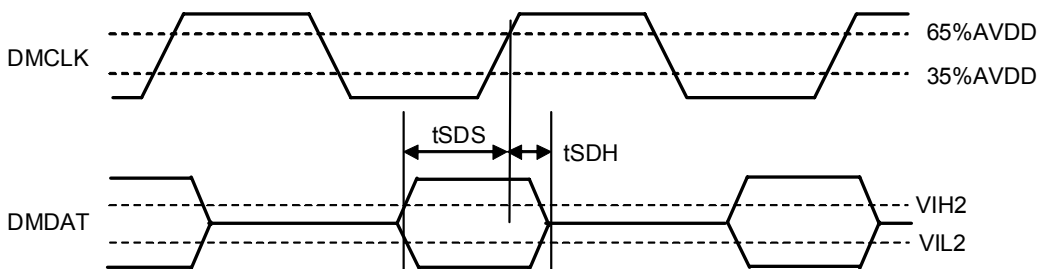

Figure 15. Audio Interface Timing (DCLKP bit = "0")

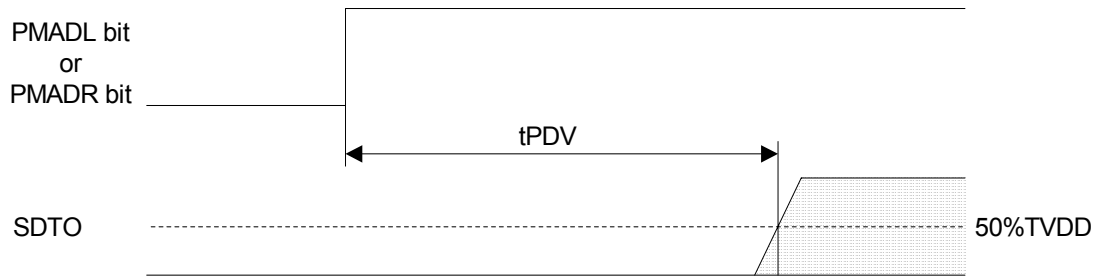

Figure 16. Power Down & Reset Timing 1

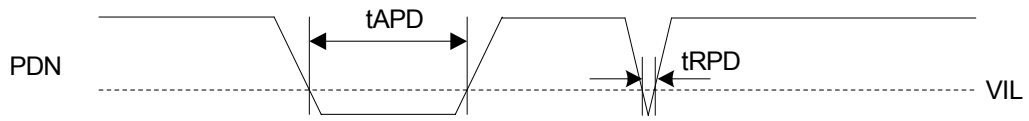

Figure 17. Power Down & Reset Timing 2

OPERATION OVERVIEW

■ System Clock

There are the following five clock modes to interface with external devices (Table 1, Table 2).

Mode	PMPLL bit	M/S bit	PLL3-0 bits	Figure
PLL Master Mode (Note 40)	1	1	Table 4	Figure 18
PLL Slave Mode 1 (PLL Reference Clock: MCKI pin)	1	0	Table 4	Figure 19
PLL Slave Mode 2 (PLL Reference Clock: BICK pin)	1	0	Table 4	Figure 20
EXT Slave Mode	0	0	x	Figure 21
EXT Master Mode	0	1	x	Figure 22

Note 40. If M/S bit = "1", PMPLL bit = "0" and MCKO bit = "1" during the setting of PLL Master Mode, the invalid clocks are output from MCKO, BICK and LRCK pins.

Table 1. Clock Mode Setting (x: Don't care)

Mode	MCKO bit	MCKO pin	MCKI pin	BICK pin	LRCK pin
PLL Master Mode	0	L	Selected by PLL3-0 bits	Output (Selected by BCKO bit)	Output (1fs)
	1	Selected by PS1-0 bits			
PLL Slave Mode (PLL Reference Clock: MCKI pin)	0	L	Selected by PLL3-0 bits	Input (≥ 32fs)	Input (1fs)
	1	Selected by PS1-0 bits			
PLL Slave Mode (PLL Reference Clock: BICK pin)	0	L	GND	Input (≥ 32fs)	Input (1fs)
EXT Slave Mode	0	L	Selected by FS3-0 bits	Input (≥ 32fs)	Input (1fs)
EXT Master Mode	0	L	Selected by FS1-0 bits	Output (Selected by BCKO bit)	Output (1fs)

Note 41. When M/S bit = "1" and MCKI is input, LRCK and BICK are output even if PMDAC=PMADL= PMADR bits = "0".

Table 2. Clock pins state in Clock Mode

■ Master Mode/Slave Mode

The M/S bit selects either master or slave mode. M/S bit = "1" selects master mode and "0" selects slave mode. When the AK4955 is in power-down mode (PDN pin = "L") and when exits reset state, the AK4955 is in slave mode. After exiting reset state, the AK4955 goes to master mode by changing M/S bit to "1".

When the AK4955 is in master mode, the LRCK and BICK pins are a floating state until M/S bit becomes "1". The LRCK and BICK pins of the AK4955 must be pulled-down or pulled-up by a resistor (about 100kΩ) externally to avoid the floating state.

M/S bit	Mode
0	Slave Mode
1	Master Mode

(default)

Table 3. Select Master/Slave Mode

■ PLL Mode

When PMPLL bit is “1”, a fully integrated analog phase locked loop (PLL) circuit generates a clock that is selected by PLL3-0 and FS3-0 bits. The PLL lock times, when the AK4955 is supplied stable clocks after PLL is powered-up (PMPLL bit = “0” → “1”) or the sampling frequency is changed, are shown in [Table 4](#).

1) PLL Mode Setting

Mode	PLL3 bit	PLL2 bit	PLL1 bit	PLL0 bit	PLL Reference Clock Input Pin	Input Frequency	PLL Lock Time (max)
2	0	0	1	0	BICK pin	32fs	2 ms
3	0	0	1	1	BICK pin	64fs	2 ms
4	0	1	0	0	MCKI pin	11.2896MHz	10 ms
6	0	1	1	0	MCKI pin	12MHz	10 ms
7	0	1	1	1	MCKI pin	24MHz	10 ms
12	1	1	0	0	MCKI pin	13.5MHz	10 ms
13	1	1	0	1	MCKI pin	27MHz	10 ms
Others	Others			N/A			

Table 4. PLL Mode Setting (*fs: Sampling Frequency, N/A: Not Available)

2) Setting of sampling frequency in PLL Mode

When PLL2 bit is “1” (PLL reference clock input is MCKI pin), the sampling frequency is selected by FS3-0 bits as defined in [Table 5](#).

Mode	FS3 bit	FS2 bit	FS1 bit	FS0 bit	Sampling Frequency
0	0	0	0	0	8kHz
1	0	0	0	1	12kHz
2	0	0	1	0	16kHz
3	0	0	1	1	24kHz
5	0	1	0	1	11.025kHz
7	0	1	1	1	22.05kHz
10	1	0	1	0	32kHz
11	1	0	1	1	48kHz
15	1	1	1	1	44.1kHz
Others	Others				N/A

Table 5. Setting of Sampling Frequency at PLL2 bit = “1” and PMPLL bit = “1” (Reference Clock = MCKI pin), (N/A: Not Available)

When PLL2 bit is “0” (PLL reference clock input pin is the BICK pin), the sampling frequency is selected by FS3-2 bits. ([Table 6](#)).

Mode	FS3 bit	FS2 bit	FS1 bit	FS0 bit	Sampling Frequency Range
0	0	0	x	x	7.35kHz ≤ fs ≤ 12kHz
1	0	1	x	x	12kHz < fs ≤ 24kHz
2	1	0	x	x	24kHz < fs ≤ 48kHz
Others	Others				N/A

Table 6. Setting of Sampling Frequency at PLL2 bit = “0” and PMPLL bit = “1” PLL Slave Mode 2 (PLL Reference Clock: BICK pin), (x: Don’t care, N/A: Not Available)

■ PLL Unlock State

1) PLL Master Mode (PMPLL bit = “1”, M/S bit = “1”)

In this mode, LRCK and BICK pins go to “L”, and irregular frequency clock is output from the MCKO pin when MCKO bit is “1” before the PLL goes to lock state after PMPLL bit = “0” → “1”. If MCKO bit is “0”, the MCKO pin outputs “L” (Table 7).

After the PLL is locked, a first period of LRCK and BICK may be invalid clock, but these clocks return to normal state after a period of 1/fs.

The BICK and LRCK pins do not output irregular frequency clocks such as PLL unlock state by setting PMPLL bit to “0”. During PMPLL bit = “0”, these pins output the same clocks as EXT Master Mode.

PLL State	MCKO pin		BICK pin	LRCK pin
	MCKO bit = “0”	MCKO bit = “1”		
After PMPLL bit “0” → “1”	“L” Output	Invalid	“L” Output	“L” Output
PLL Unlock (except the case above)	“L” Output	Invalid	Invalid	Invalid
PLL Lock	“L” Output	Table 9	Table 10	1fs Output

Table 7. Clock Operation at PLL Master Mode (PMPLL bit = “1”, M/S bit = “1”)

2) PLL Slave Mode (PMPLL bit = “1”, M/S bit = “0”)

In this mode, an invalid clock is output from the MCKO pin before the PLL goes to lock state after PMPLL bit = “0” → “1”. Then, the clock selected by Table 9 is output from the MCKO pin when PLL is locked. ADC and DAC output invalid data when the PLL is unlocked. The DAC outputs can be muted by setting DACL and DACS bits to “0”.

PLL State	MCKO pin	
	MCKO bit = “0”	MCKO bit = “1”
After PMPLL bit “0” → “1”	“L” Output	Invalid
PLL Unlock (except the case above)	“L” Output	Invalid
PLL Lock	“L” Output	Output

Table 8. Clock Operation at PLL Slave Mode (PMPLL bit = “0”, M/S bit = “0”)

■ PLL Master Mode (PMPLL bit = “1”, M/S bit = “1”)

When an external clock (11.2896MHz, 12MHz, 13.5MHz, 24MHz or 27MHz) is input to the MCKI pin, the internal PLL circuit generates MCKO, BICK and LRCK clocks. The MCKO output frequency is selected by PS1-0 bits (Table 9) and switched on and off by MCKO bit. The BICK output frequency is selected between 32fs or 64fs, by BCKO bit (Table 10).

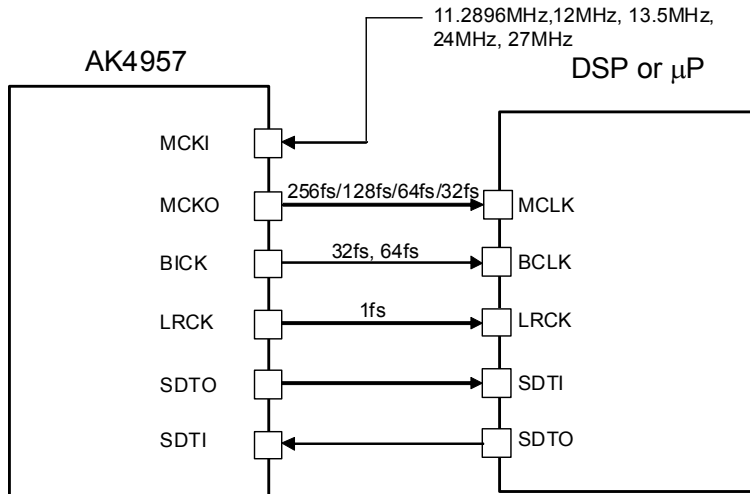

Figure 18. PLL Master Mode

Mode	PS1 bit	PS0 bit	MCKO pin
0	0	0	256fs
1	0	1	128fs
2	1	0	64fs
3	1	1	32fs

(default)

Table 9. MCKO Output Frequency (PLL Mode, MCKO bit = “1”)

BCKO bit	BICK Output Frequency
0	32fs
1	64fs

(default)

Table 10. BICK Output Frequency at Master Mode

■ PLL Slave Mode (PMPLL bit = “1”, M/S bit = “0”)

A reference clock of PLL is selected among the input clocks to the MCKI or BICK pins. The required clock for the AK4955 is generated by an internal PLL circuit. Input frequency is selected by PLL3-0 bits (Table 4).

a) PLL reference clock: MCKI pin

The BICK and LRCK inputs must be synchronized with MCKO output. The phase between MCKO and LRCK is not important. The MCKO pin outputs the frequency selected by PS1-0 bits (Table 9) and the output is enabled by MCKO bit. Sampling frequency can be selected by FS3-0 bits (Table 5)

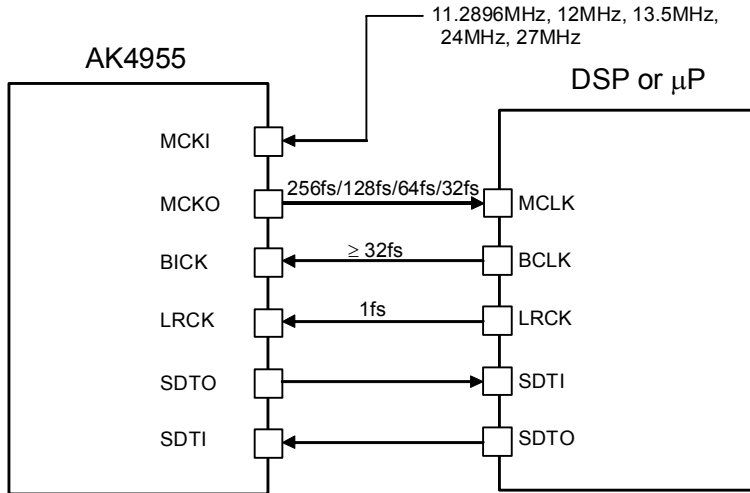

Figure 19. PLL Slave Mode 1 (PLL Reference Clock: MCKI pin)

b) PLL reference clock: BICK pin

The sampling frequency corresponds to a range from 7.35kHz to 48kHz by changing FS3-0 bits (Table 6).

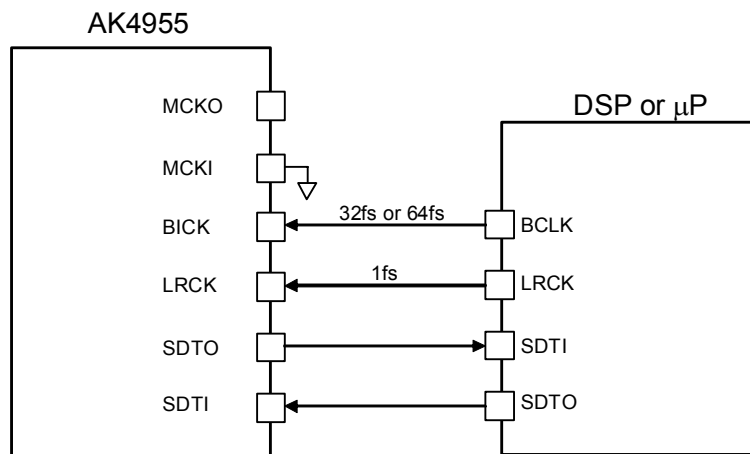

Figure 20. PLL Slave Mode 2 (PLL Reference Clock: BICK pin)

■ EXT Slave Mode (PMPLL bit = “0”, M/S bit = “0”)

When PMPLL bit is “0”, the AK4955 becomes EXT mode. Master clock can be input to the internal ADC and DAC directly from the MCKI pin without internal PLL circuit operation. This mode is compatible with I/F of a normal audio CODEC. The external clocks required to operate this mode are MCKI (256fs, 512fs or 1024fs), LRCK (fs) and BICK ($\geq 32fs$). The master clock (MCKI) must be synchronized with LRCK. The phase between these clocks is not important. The input frequency of MCKI is selected by FS1-0 bits (Table 11).

Mode	FS3-2 bits	FS1 bit	FS0 bit	MCKI Input Frequency	Sampling Frequency Range
0	x	0	0	256fs	7.35kHz ~ 48kHz
1	x	0	1	1024fs	7.35kHz ~ 13kHz
2	x	1	0	512fs	7.35kHz ~ 26kHz
3	x	1	1	512fs	7.35kHz ~ 48kHz

(x: Don't care)

Table 11. MCKI Frequency at EXT Slave Mode (PMPLL bit = “0”, M/S bit = “0”)

The S/N of the DAC at low sampling frequencies is worse than at high sampling frequencies due to out-of-band noise. The out-of-band noise can be reduced by using higher frequency of the master clock. The S/N of the DAC output through LOUT/ROUT pins is shown in Table 12.

MCKI	S/N (fs=8kHz, 20kHzLPF + A-weighted)
Mode0: 256fs Mode3: 512fs	80dB
Mode2: 512fs	92dB
Mode1: 1024fs	92dB

Table 12. Relationship between MCKI and S/N of LOUT/ROUT pins

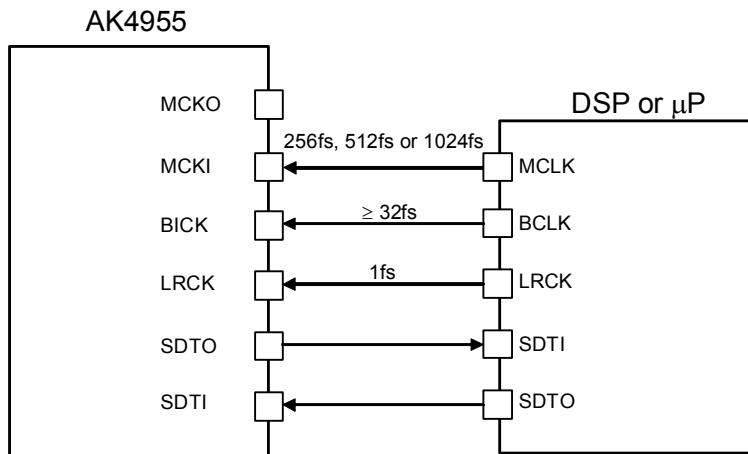

Figure 21. EXT Slave Mode

■ EXT Master Mode (PMPLL bit = “0”, M/S bit = “1”)

The AK4955 becomes EXT Master Mode by setting PMPLL bit = “0” and M/S bit = “1”. Master clock can be input to the internal ADC and DAC directly from the MCKI pin without the internal PLL circuit operation. The external clock required to operate the AK4955 is MCKI (256fs, 512fs or 1024fs). The input frequency of MCKI is selected by FS1-0 bits (Table 13).

Mode	FS3-2 bits	FS1 bit	FS0 bit	MCKI Input Frequency	Sampling Frequency Range
0	x	0	0	256fs	7.35kHz ~ 48kHz
1	x	0	1	1024fs	7.35kHz ~ 13kHz
2	x	1	0	512fs	7.35kHz ~ 26kHz
3	x	1	1	512fs	7.35kHz ~ 48kHz

(default)

Table 13. MCKI Frequency at EXT Master Mode (PMPLL bit = “0”, M/S bit = “1”) (x: Don’t care)

The S/N of the DAC at low sampling frequencies is worse than at high sampling frequencies due to out-of-band noise. The out-of-band noise can be reduced by using higher frequency of the master clock. The S/N of the DAC output through LOUT/ROUT pins is shown in Table 14.

MCKI	S/N (fs=8kHz, 20kHzLPF + A-weighted)
Mode0; 256fs Mode3; 512fs	80dB
Mode2; 512fs	92dB
Mode1; 1024fs	92dB

Table 14. Relationship between MCKI and S/N of LOUT/ROUT pins

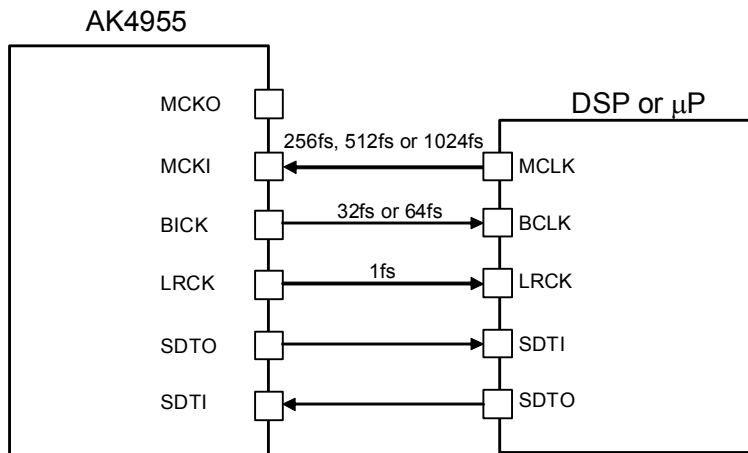

Figure 22. EXT Master Mode

BCKO bit	BICK Output Frequency
0	32fs
1	64fs

(default)

Table 15. BICK Output Frequency at Master Mode

■ System Reset

Upon power-up, the AK4955 must be reset by bringing the PDN pin = “L”. This reset is released when a dummy command is input after the PDN pin = “H”. This ensures that all internal registers reset to their initial value. Dummy command is executed by writing all “0” to the register address 00H. It is recommended to set the PDN pin to “L” before power up the AK4955.

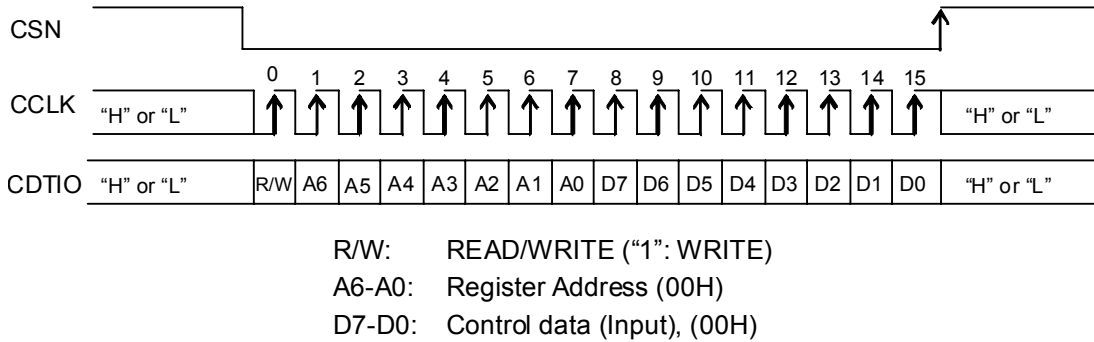

Figure 23. Dummy Command in 3-wire Serial Mode

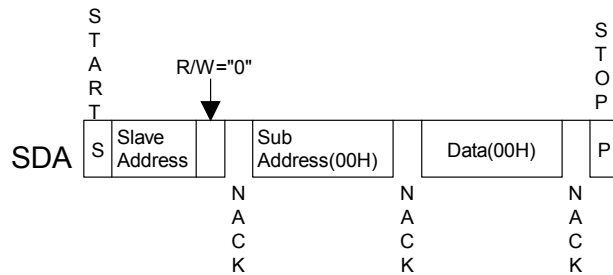

Figure 24. Dummy Command in I²C-bus Mode

The ADC starts an initialization cycle if the one of PMADL or PMADR is set to “1” when both of the PMADL and PMADR bits are “0”. The initialization cycle is set by ADRST1-0 bits (Table 16). During the initialization cycle, the ADC digital data outputs of both channels are forced to “0” in 2’s complement. The ADC output reflects the analog input signal after the initialization cycle is finished. When using a digital microphone, the initialization cycle is the same as ADC’s.

(Note) The initial data of ADC has offset data that depends on microphones and the cut-off frequency of HPF. If this offset is not small, make initialization cycle longer by setting ADRST1-0 bits or do not use the first data of ADC outputs.

ADRST1-0 bits	Init Cycle			
	Cycle	fs = 8kHz	fs = 16kHz	fs = 48kHz
00	1059/fs	132.4ms	66.2ms	22ms
01	267/fs	33.4ms	16.7ms	5.6ms
10	531/fs	66.4ms	33.2ms	11.1ms
11	135/fs	16.9ms	8.4ms	2.8ms

(default)

Table 16. ADC Initialization Cycle

■ Audio Interface Format

Four types of data formats are available and selected by setting the DIF1-0 bits (Table 17). In all modes, the serial data is MSB first, 2's complement format. Audio interface formats are supported in both master and slave modes. LRCK and BICK are output from the AK4955 in master mode, but must be input to the AK4955 in slave mode. The SDTO is clocked out on the falling edge ("↓") of BICK and the SDTI is latched on the rising edge ("↑") of BICK.

Mode	DIF1 bit	DIF0 bit	SDTO (ADC)	SDTI (DAC)	BICK	Figure
0	0	0	24bit MSB justified	24bit LSB justified	≥ 48fs	Figure 25
1	0	1	24bit MSB justified	16bit LSB justified	≥ 32fs	Figure 26
2	1	0	24bit MSB justified	24bit MSB justified	≥ 48fs	Figure 27 (default)
3	1	1	I ² S Compatible	I ² S Compatible	=32fs or ≥ 48fs	Figure 28

Table 17. Audio Interface Format

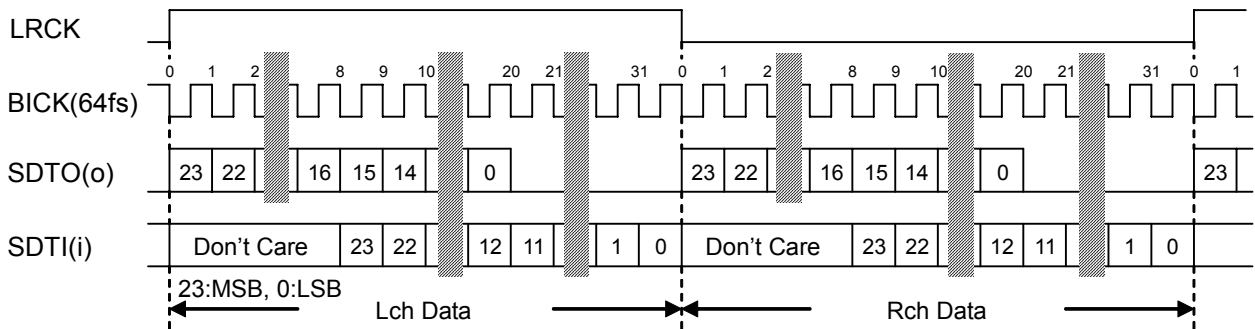

Figure 25. Mode 0 Timing

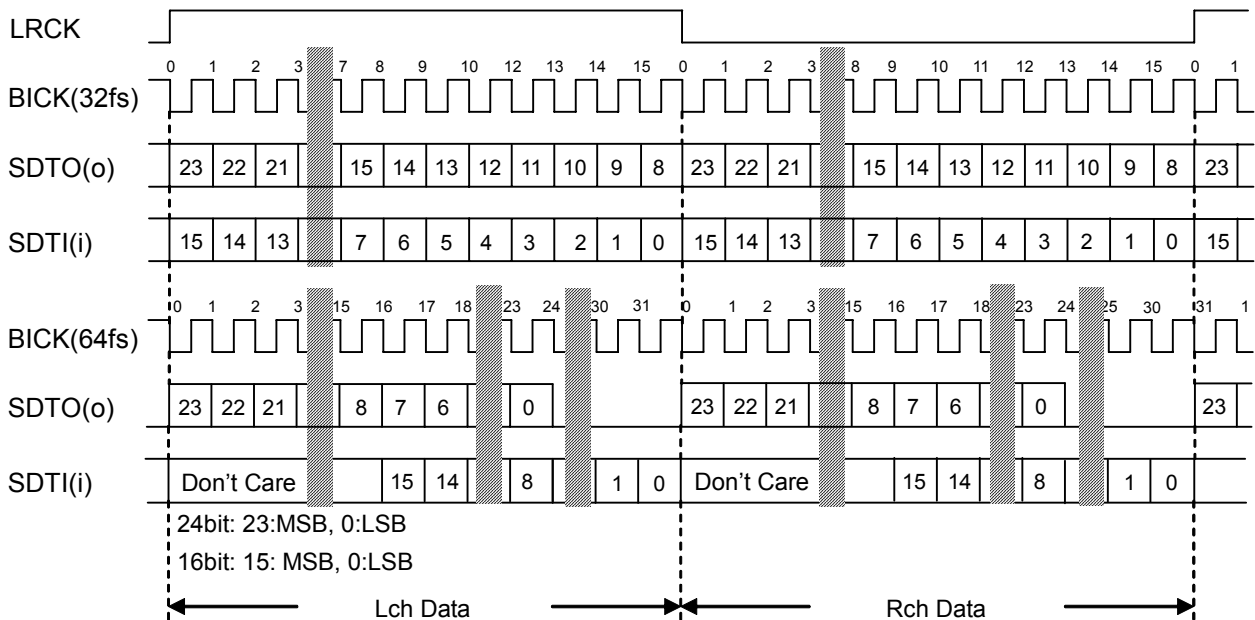

Figure 26. Mode 1 Timing

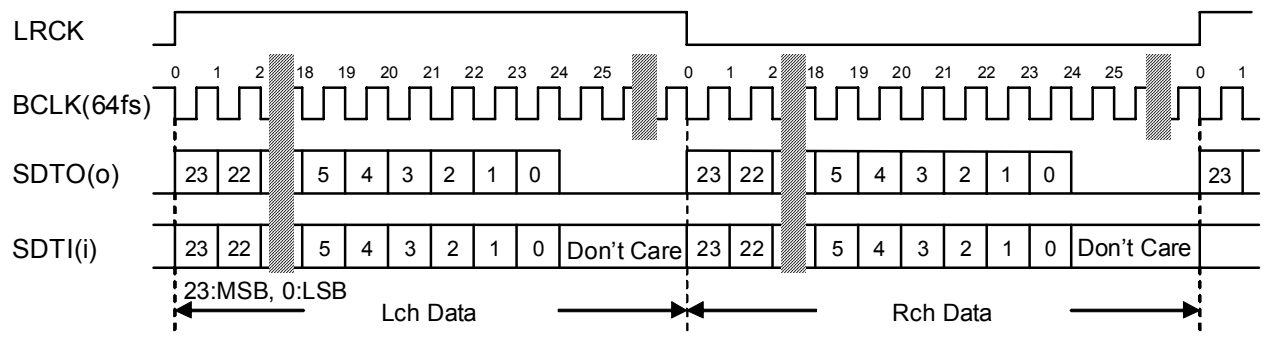

Figure 27. Mode 2 Timing

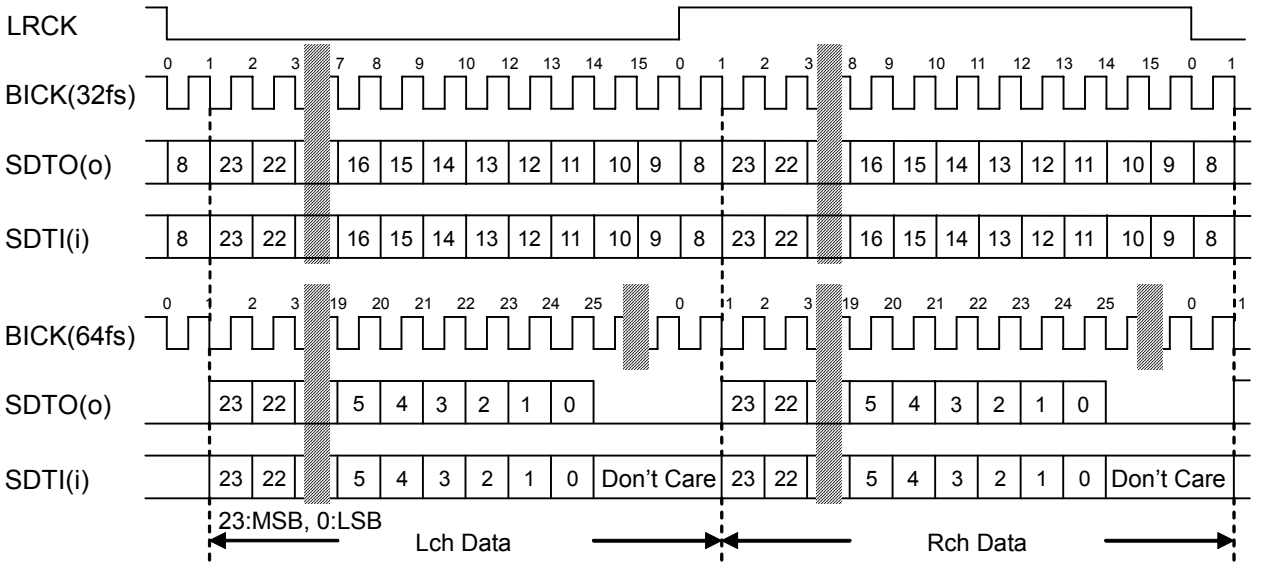

Figure 28. Mode 3 Timing

■ Mono/Stereo Mode

PMADL, PMADR, PMDML and PMDMR bits set mono/stereo ADC operation. When changing ADC operation and analog/digital microphone, PMADL, PMADR, PMDML and PMDMR bits must be set “0” at first. When PMDML or PMDMR bit = “1”, PMADL and PMADR bit settings are ignored.

PMADL bit	PMADR bit	ADC Lch data	ADC Rch data	
0	0	All “0”	All “0”	(default)
0	1	Rch Input Signal	Rch Input Signal	
1	0	Lch Input Signal	Lch Input Signal	
1	1	Lch Input Signal	Rch Input Signal	

Table 18. Mono/Stereo ADC operation (Analog MIC)

PMDML bit	PMDMR bit	ADC Lch data	ADC Rch data	
0	0	All “0”	All “0”	(default)
0	1	Rch Input Signal	Rch Input Signal	
1	0	Lch Input Signal	Lch Input Signal	
1	1	Lch Input Signal	Rch Input Signal	

Table 19. Mono/Stereo ADC operation (Digital MIC)

■ MIC/LINE Input Selector

The AK4955 has an input selector. INL and INR bits select LIN1/LIN2 and RIN1/RIN2, respectively. When DMIC bit = “1”, digital microphone input is selected regardless of INL and INR bits.

DMIC bit	INL bit	INR bit	Lch	Rch	
0	0	0	LIN1	RIN1	(default)
	0	1	LIN1	RIN2	
	1	0	LIN2	RIN1	
	1	1	LIN2	RIN2	
1	x	x	Digital Microphone		

Table 20. MIC/Line In Path Select (x: Don't care)

■ MIC Gain Amplifier

The AK4955 has a gain amplifier for microphone input. The gain of MIC-Amp is selected by the MGAIN3-0 bits (Table 21). The typical input impedance is 33kΩ.

MGAIN3 bit	MGAIN2 bit	MGAIN1 bit	MGAIN0 bit	Input Gain	
0	0	0	0	0dB	(default)
0	0	0	1	+5dB	
0	0	1	0	+8dB	
0	0	1	1	+11dB	
0	1	0	0	+14dB	
0	1	0	1	+16dB	
0	1	1	0	+18dB	
0	1	1	1	+21dB	
1	0	0	0	+24dB	
Others				N/A	

Table 21. Input Gain (N/A: Not available)

■ MIC Power

When PMMP bit = “1”, the MPWR pin supplies the power for microphones. This output voltage is typically 2.5V @MICL bit = “0” (AVDD=2.9~3.6V), and typically 2.2V @MICL bit = “1” (AVDD=2.7V~3.6V). The load resistance is minimum 0.5k Ω . In case of using two sets of stereo microphones, the load resistance is minimum 2k Ω for each channel. Any capacitor must not be connected directly to the MPWR pin (Figure 29).

PMMP bit	MPWR pin
0	Hi-Z
1	Output

(default)

Table 22. MIC Power

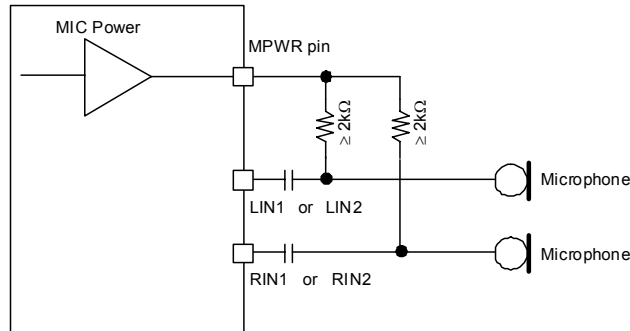

Figure 29. MIC Block Circuit

■ Digital MIC

1. Connection to Digital Microphones

When DMIC bit is set to “1”, the LIN1 and RIN1 pins become DMDAT (digital microphone data input) and DMCLK (digital microphone clock supply) pins, respectively. The same voltage as AVDD must be provided to the digital microphone. The Figure 30 and Figure 31 show stereo/mono connection examples. The DMCLK clock is input to a digital microphone from the AK4955. The digital microphone outputs 1bit data, which is generated by $\Delta\Sigma$ Modulator using DMCLK clock, to the DMDAT pin. PMDML/R bits control power up/down of the digital block (Decimation Filter and Digital Filter). (PMADL/PMADR bits settings do not affect the digital microphone power management. Set PMMP = PMMICL/R bits to “0” when using a digital microphone.) The DCLKE bit controls ON/OFF of the output clock from the DMCLK pin. When the AK4955 is powered down (PDN pin= “L”), the DMCLK and DMDAT pins become floating state. Pull-down resistors must be connected to DMCLK and DMDAT pins externally to avoid this floating state.

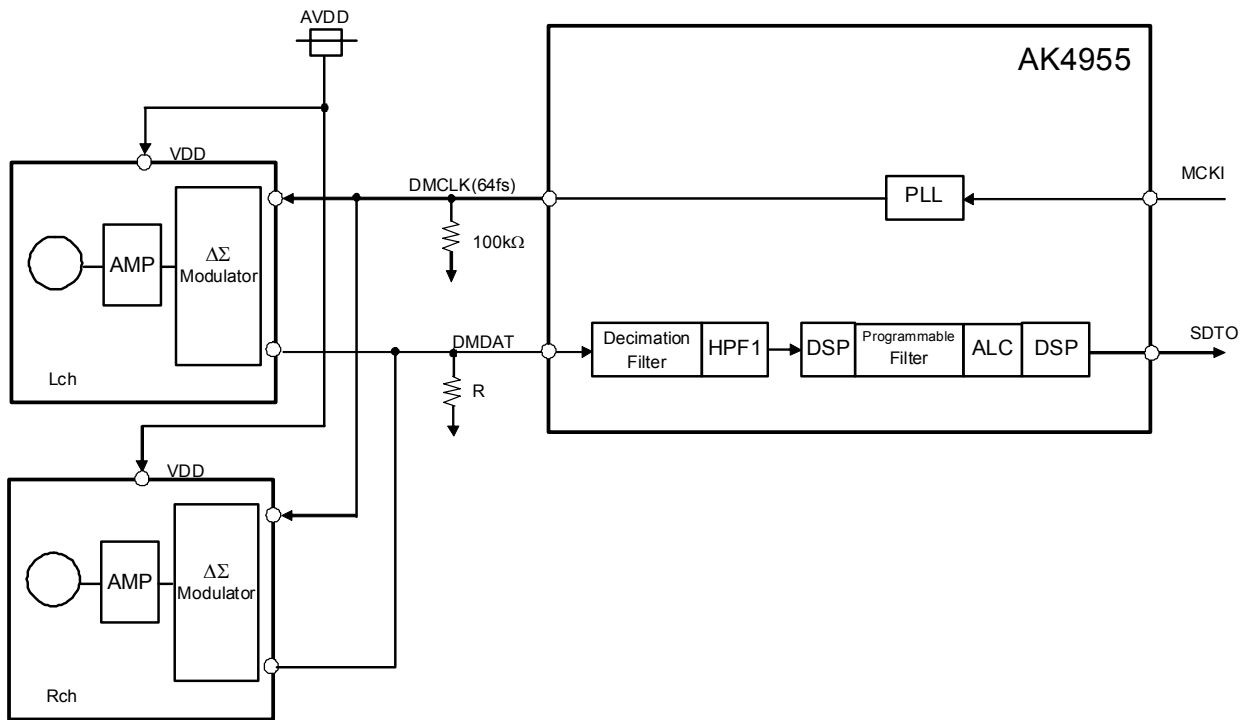

Figure 30. Connection Example of Stereo Digital MIC

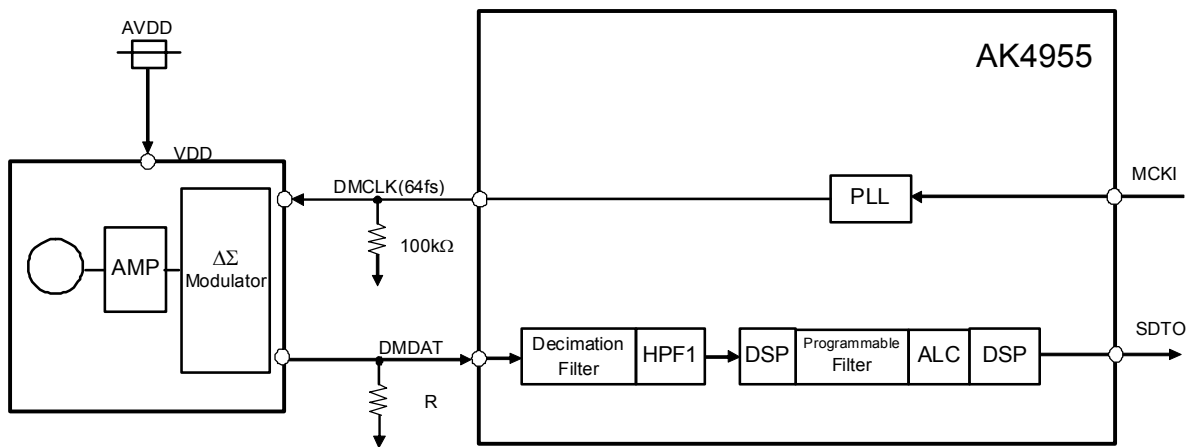

Figure 31. Connection Example of Mono Digital MIC

2. Interface

The input data channel of the DMDAT pin is set by DCLKP bit. When DCLKP bit = “1”, L channel data is input to the decimation filter if DMCLK = “H”, and R channel data is input if DMCLK = “L”. When DCLKP bit = “0”, R channel data is input to the decimation filter while DMCLK pin= “H”, and L channel data is input while DMCLK pin= “L”. The DMCLK pin only supports 64fs. It outputs “L” when DCLKE bit = “0”, and outputs 64fs when DCLKE bit = “1”. In this case, necessary clocks must be supplied to the AK4955 for ADC operation. The output data through “the Decimation and Digital Filters” is 24bit full scale when the 1bit data density is 0%~100%.

DCLKP bit	DMCLK pin= “H”	DMCLK pin= “L”
0	Rch	Lch
1	Lch	Rch

(default)

Table 23. Data In/Output Timing with Digital MIC (DCLKP bit = “0”)

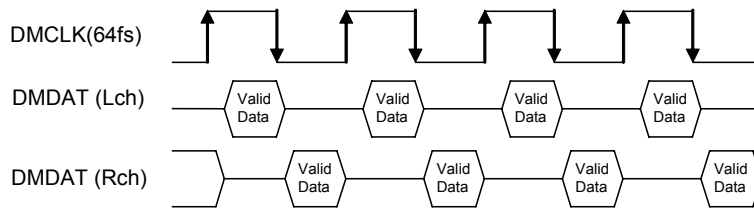

Figure 32. Data In/Output Timing with Digital MIC (DCLKP bit = “1”)

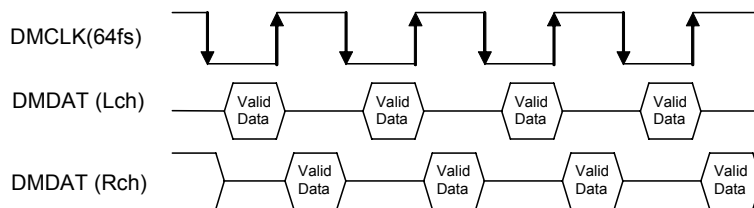
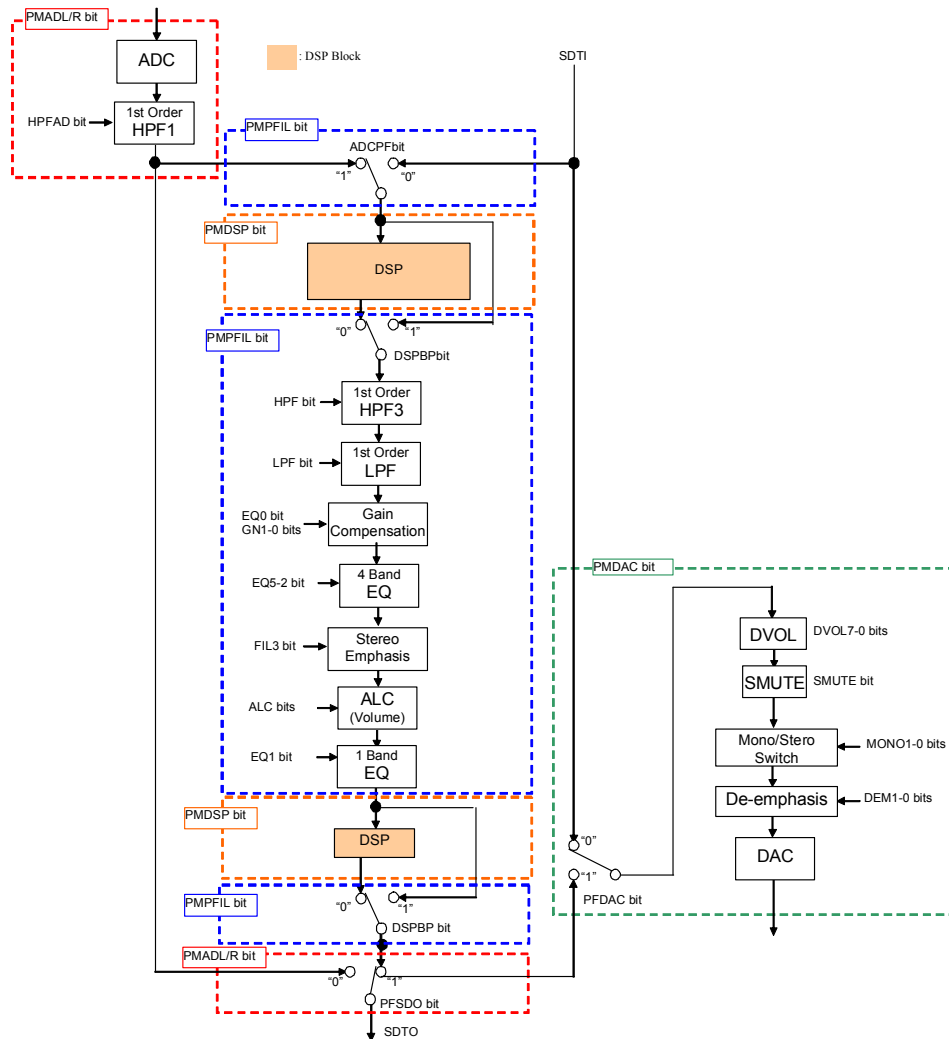

Figure 33. Data In/Output Timing with Digital MIC (DCLKP bit = “0”)

■ Digital Block

The digital block consists of the blocks shown in Figure 34. Recording path and playback path are selected by setting ADCPF bit, PFDAC bit, PFSDO bit and DSPBP bit. (Figure 35 ~Figure 41, Table 24)



- (1) ADC: Includes the Digital Filter (LPF) for ADC as shown in “FILTER CHARACTERISTICS”.
- (2) HPF1: High Pass Filter (HPF) for ADC as shown in “Digital HPF1”.
- (3) HPF3: High Pass Filter (“Digital Programmable Filter Circuit”)
- (4) LPF: Low Pass Filter (See “Digital Programmable Filter Circuit”)
- (5) Gain Compensation: Gain compensation consists of EQ and Gain control. It corrects frequency characteristics after stereo separation emphasis filter. (See “Digital Programmable Filter Circuit”)
- (6) 4 Band EQ: Applicable for use as Equalizer or Notch Filter. (See “Digital Programmable Filter Circuit”)
- (7) Stereo Emphasis: Stereo emphasis filter (See “Digital Programmable Filter Circuit”)
- (8) ALC (Volume): Digital Volume with ALC Function. (See “Input Digital Volume” and “ALC Operation”)
- (9) 1 Band EQ: Applicable for use as a Notch Filter (See “Digital Programmable Filter Circuit”)
- (10) DVOL: Digital volume for playback path (See “Output Digital Volume2”)
- (11) SMUTE: Soft mute function
- (12) Mono/Stereo Switching: Mono/Stereo lineout outputs select from DAC which described in <Mono Mixing Output> at “Stereo Line Outputs”.
- (13) De-emphasis: De-emphasis filter (See “De-emphasis Filter Control”)

Figure 34. Digital Block Path Select

Mode	ADCPF bit	PFDAC bit	PFSDO bit	DSPBP bit	Figure
Recording Mode 1	1	0	1	0	Figure 35
Playback Mode 1	0	1	0	0	Figure 36
Recording Mode 2	1	0	1	1	Figure 37
Playback Mode 2	0	1	0	1	Figure 38
Recording Mode 3 & Playback Mode 3	x	0	0	x	Figure 39
Loopback 1	1	1	1	0	Figure 40
Loopback 2	1	1	1	1	Figure 41

Table 24. Recording Playback Mode (x: Don't care)

When changing those modes, PMPFIL bit must be "0".

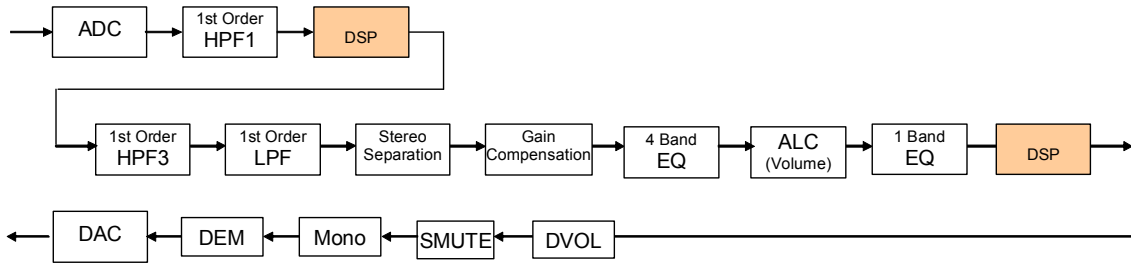

Figure 35. The Path in Recording Mode 1

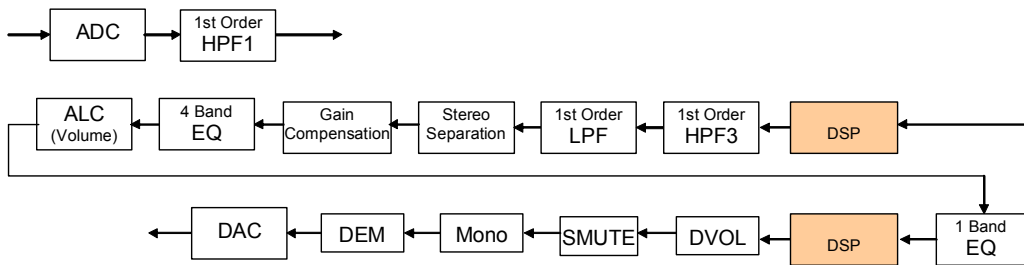

Figure 36. The Path in Playback Mode 1

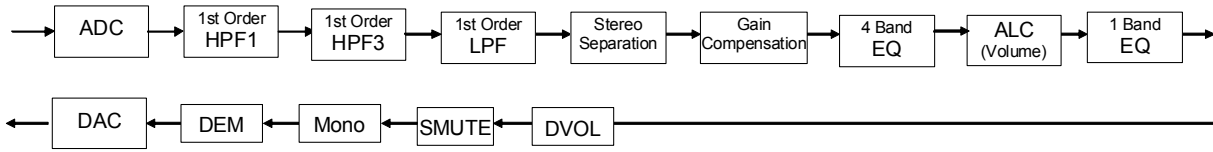

Figure 37. The Path in Recording Mode 2

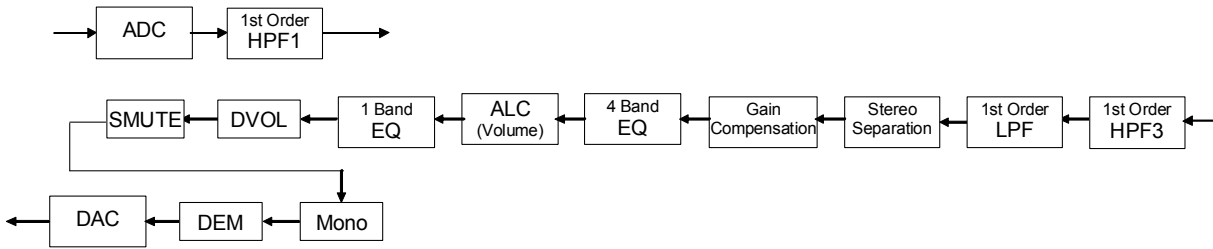

Figure 38. The Path in Playback Mode 2

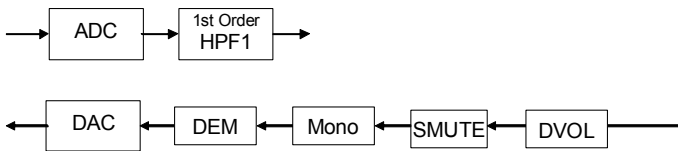

Figure 39. The Path in Recording Mode 3 & Playback Mode 3

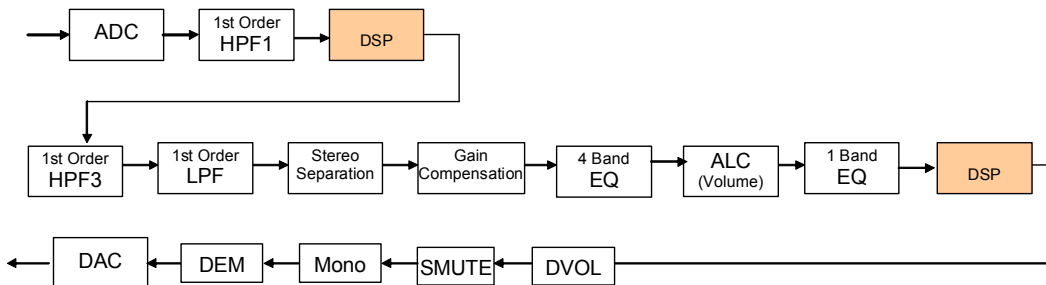

Figure 40. The Path in Loopback Mode 1

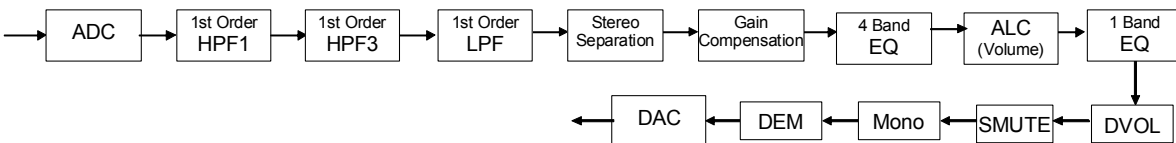

Figure 41. The Path in Loopback Mode 2

■ Digital HPF1

A digital High Pass Filter (HPF) is integrated for DC offset cancellation of the ADC input. The cut-off frequencies of the HPF1 are set by HPFC1-0 bits (Table 25). It is proportional to the sampling frequency (f_s) and the default value is 3.7Hz (@ $f_s = 48\text{kHz}$). HPFAD bit controls the ON/OFF of the HPF1 (HPF ON is recommended).

HPFC1 bit	HPFC0 bit	f_c			(default)
		$f_s=48\text{kHz}$	$f_s=22.05\text{kHz}$	$f_s=8\text{kHz}$	
0	0	3.7Hz	1.7Hz	0.62Hz	(default)
0	1	14.8Hz	6.8Hz	2.47Hz	
1	0	118.4Hz	54.4Hz	19.7Hz	
1	1	236.8Hz	108.8Hz	39.5Hz	

Table 25. HPF1 Cut-off Frequency

■ Digital Programmable Filter Circuit

(1) High Pass Filter (HPF3)

This is composed 1st order HPF. The coefficient of HPF is set by F1A13-0 bits and F1B13-0 bits. HPF bit controls ON/OFF of the HPF3. When the HPF3 is OFF, the audio data passes this block by 0dB gain. The coefficient must be set when PMPFIL bit = "0" or HPF bit = "0". The HPF3 starts operation $4/f_s$ (max) after when HPF bit=PMPFIL bit="1" is set.

f_s : Sampling Frequency
 f_c : Cutoff Frequency

Register Setting (Note 42)

HPF: F1A[13:0] bits =A, F1B[13:0] bits =B
 (MSB=F1A13, F1B13; LSB=F1A0, F1B0)

$$A = \frac{1 / \tan(\pi f_c / f_s)}{1 + 1 / \tan(\pi f_c / f_s)}, \quad B = \frac{1 - 1 / \tan(\pi f_c / f_s)}{1 + 1 / \tan(\pi f_c / f_s)}$$

Transfer Function

$$H(z) = A \frac{1 - z^{-1}}{1 + Bz^{-1}}$$

The cut-off frequency must be set as below.

$$f_c / f_s \geq 0.0001 \quad (f_c \text{ min} = 4.8\text{Hz at } 48\text{kHz})$$

(2) Low Pass Filter (LPF)

This is composed with 1st order LPF. F2A13-0 bits and F2B13-0 bits set the coefficient of LPF. LPF bit controls ON/OFF of the LPF. When the LPF is OFF, the audio data passes this block by 0dB gain. The coefficient must be set when PMPFIL bit = "0" or LPF bit = "0". The LPF starts operation $4/f_s$ (max) after when LPF bit =PMPFIL bit="1" is set.

f_s : Sampling Frequency
 f_c : Cutoff Frequency

Register Setting (Note 42)

LPF: F2A[13:0] bits =A, F2B[13:0] bits =B
 (MSB=F2A13, F1B13; LSB=F2A0, F2B0)

$$A = \frac{1}{1 + 1 / \tan(\pi f_c / f_s)}, \quad B = \frac{1 - 1 / \tan(\pi f_c / f_s)}{1 + 1 / \tan(\pi f_c / f_s)}$$

Transfer Function

$$H(z) = A \frac{1 + z^{-1}}{1 + Bz^{-1}}$$

The cut-off frequency must be set as below.

$$f_c / f_s \geq 0.05 \quad (f_c \text{ min} = 2400\text{Hz at } 48\text{kHz})$$

(3) Stereo Separation Emphasis Filter (FIL3)

The FIL3 is used to emphasize the stereo separation of stereo microphone recording data and playback data. F3A13-0 bits and F3B13-0 bits set the filter coefficients of the FIL3. When F3AS bit = "0", the FIL3 performs as a High Pass Filter (HPF), and it performs as a Low Pass Filter (LPF) when F3AS bit = "1". FIL3 bit controls ON/OFF of the FIL3. When the stereo separation emphasis filter is OFF, the audio data passes this block by 0dB gain. The coefficient should be set when FIL3 bit or PMPFIL bit is "0". The FIL3 starts operation $4/f_s(\max)$ after when FIL3 bit = PMPFIL bit = "1" is set.

1) In case of setting FIL3 as HPF

f_s : Sampling Frequency

f_c : Cutoff Frequency

K: Gain [dB] ($0\text{dB} \geq K \geq -10\text{dB}$)

Register Setting (Note 42)

FIL3: F3AS bit = "0", F3A[13:0] bits = A, F3B[13:0] bits = B
(MSB=F3A13, F3B13; LSB=F3A0, F3B0)

$$A = 10^{K/20} \times \frac{1 / \tan(\pi f_c / f_s)}{1 + 1 / \tan(\pi f_c / f_s)}, \quad B = \frac{1 - 1 / \tan(\pi f_c / f_s)}{1 + 1 / \tan(\pi f_c / f_s)}$$

Transfer Function

$$H(z) = A \frac{1 - z^{-1}}{1 + Bz^{-1}}$$

2) In case of setting FIL3 as LPF

f_s : Sampling Frequency

f_c : Cutoff Frequency

K: Gain [dB] ($0\text{dB} \geq K \geq -10\text{dB}$)

Register Setting (Note 42)

FIL3: F3AS bit = "1", F3A[13:0] bits = A, F3B[13:0] bits = B
(MSB=F3A13, F3B13; LSB= F3A0, F3B0)

$$A = 10^{K/20} \times \frac{1}{1 + 1 / \tan(\pi f_c / f_s)}, \quad B = \frac{1 - 1 / \tan(\pi f_c / f_s)}{1 + 1 / \tan(\pi f_c / f_s)}$$

Transfer Function

$$H(z) = A \frac{1 + z^{-1}}{1 + Bz^{-1}}$$

(4) Gain Compensation (EQ0)

Gain compensation is used to compensate the frequency response and the gain that is changed by the stereo separation emphasis filter. Gain compensation is composed of the Equalizer (EQ0) and the Gain (0dB/+12dB/+24dB). E0A15-0 bits, E0B13-0 bits and E0C15-0 bits set the coefficient of EQ0. GN1-0 bits set the gain (Table 26). EQ0 bit controls ON/OFF of EQ0. When EQ is OFF and the gain is 0dB, the audio data passes this block by 0dB gain. The coefficient should be set when EQ0 bit = "0" or PMPFIL bit = "0". The EQ0 starts operation 4/fs(max) after when EQ0 bit = PMPFIL bit = "1" is set.

- fs: Sampling Frequency
- fc₁: Polar Frequency
- fc₂: Zero-point Frequency
- K: Gain [dB] (Maximum setting is +12dB.)

Register Setting (Note 42)

E0A[15:0] bits =A, E0B[13:0] bits =B, E0C[15:0] bits =C
 (MSB=E0A15, E0B13, E0C15; LSB=E0A0, E0B0, E0C0)

$$A = 10^{K/20} \times \frac{1 + 1 / \tan(\pi fc_2 / fs)}{1 + 1 / \tan(\pi fc_1 / fs)}, \quad B = \frac{1 - 1 / \tan(\pi fc_1 / fs)}{1 + 1 / \tan(\pi fc_1 / fs)}, \quad C = 10^{K/20} \times \frac{1 - 1 / \tan(\pi fc_2 / fs)}{1 + 1 / \tan(\pi fc_1 / fs)}$$

Transfer Function

$$H(z) = \frac{A + Cz^{-1}}{1 + Bz^{-1}}$$

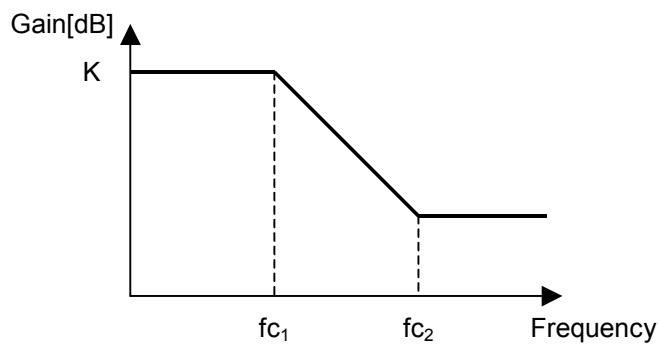

Figure 42. EQ0 Frequency Response

GN1 bit	GN0 bit	Gain
0	0	0dB
0	1	+12dB
1	x	+24dB

(default)

Table 26. Gain Setting (x: Don't care)

(5) 4-band Equalizer & 1-band Equalizer after ALC

This block can be used as equalizer or Notch Filter. 4-band equalizers (EQ2~EQ5) are switched ON/OFF independently by EQ2, EQ3, EQ4 and EQ5 bits. EQ1 bit controls ON/OFF switching of the equalizer after ALC (EQ1). When the equalizer is OFF, the audio data passes this block by 0dB gain. E1A15-0 bits, E1B15-0 bits and E1C15-0 bits set the coefficient of EQ1. E2A15-0 bits, E2B15-0 bits and E2C15-0 bits set the coefficient of EQ2. E3A15-0 bits, E3B15-0 bits and E3C15-0 bits set the coefficient of EQ3. E4A15-0 bits, E4B15-0 bits and E4C15-0 bits set the coefficient of EQ4. E5A15-0 bits, E5B15-0 bits and E5C15-0 bits set the coefficient of EQ5. The EQ_x (x=1, 2, 3, 4 or 5) coefficient must be set when EQ_x bit = "0" or PMPFIL bit = "0". EQ_x starts operation 4/fs(max) after when EQ_x = PMPFIL bit = "1" is set.

fs: Sampling Frequency

fo₁ ~ fo₅: Center Frequency

fb₁ ~ fb₅: Band width where the gain is 3dB different from the center frequency

K₁ ~ K₅: Gain (-1 ≤ K_n < 3)

Register Setting (Note 42)

EQ1: E1A[15:0] bits =A₁, E1B[15:0] bits =B₁, E1C[15:0] bits =C₁

EQ2: E2A[15:0] bits =A₂, E2B[15:0] bits =B₂, E2C[15:0] bits =C₂

EQ3: E3A[15:0] bits =A₃, E3B[15:0] bits =B₃, E3C[15:0] bits =C₃

EQ4: E4A[15:0] bits =A₄, E4B[15:0] bits =B₄, E4C[15:0] bits =C₄

EQ5: E5A[15:0] bits =A₅, E5B[15:0] bits =B₅, E5C[15:0] bits =C₅

(MSB=E1A15, E1B15, E1C15, E2A15, E2B15, E2C15, E3A15, E3B15, E3C15, E4A15, E4B15, E4C15, E5A15, E5B15, E5C15 ; LSB= E1A0, E1B0, E1C0, E2A0, E2B0, E2C0, E3A0, E3B0, E3C0, E4A0, E4B0, E4C0, E5A0, E5B0, E5C0)

$$A_n = K_n \times \frac{\tan(\pi fb_n/fs)}{1 + \tan(\pi fb_n/fs)}, \quad B_n = \cos(2\pi fo_n/fs) \times \frac{2}{1 + \tan(\pi fb_n/fs)}, \quad C_n = -\frac{1 - \tan(\pi fb_n/fs)}{1 + \tan(\pi fb_n/fs)}$$

(n = 1, 2, 3, 4, 5)

Transfer Function

$$H(z) = \{1 + G_2 \times h_2(z) + G_3 \times h_3(z) + G_4 \times h_4(z) + G_5 \times h_5(z)\} \times \{1 + h_1(z)\}$$

(G_{2,3,4,5} = 1 or G)

$$h_n(z) = A_n \frac{1 - z^{-2}}{1 - B_n z^{-1} - C_n z^{-2}}$$

(n = 1, 2, 3, 4, 5)

The center frequency must be set as below.

$$fo_n / fs < 0.497$$

When gain of K is set to "-1", this equalizer becomes a notch filter. When EQ2 ~EQ5 is used as a notch filter, central frequency of a real notch filter deviates from the above-mentioned calculation, if its central frequency of each band is near. The control soft that is attached to the evaluation board has functions that revises a gap of frequency and calculates the coefficient. When its central frequency of each band is near, the central frequency should be revised and confirm the frequency response.

Note 42.

[Translation the filter coefficient calculated by the equations above from real number to binary code (2's complement)]

$$X = (\text{Real number of filter coefficient calculated by the equations above}) \times 2^{13}$$

X should be rounded to integer, and then should be translated to binary code (2's complement).

MSB of each filter coefficient setting register is sine bit.

■ ALC Operation

The ALC (Automatic Level Control) is operated by ALC block. When ADCPF bit is “1”, the ALC circuit operates for recording path, and the ALC circuit operates for playback path when ADCPF bit is “0”. ALC1 bit controls ON/OFF of ALC operation at recording path, and ALC2 bit controls ON/OFF of ALC operation at playback path.

Note 43. In this section, VOL means IVL and IVR for recording path, OVL and OVR for playback path.

Note 44. In this section, ALC means ALC1 for recording path, ALC2 for playback path.

Note 45. In this section, REF means IREF for recording path, OREF for playback path.

1. ALC Limiter Operation

During ALC limiter operation, when either L or R channel output level exceeds the ALC limiter detection level (Table 27), the VOL value (same value for both L and R) is attenuated automatically by the amount defined by the ALC limiter ATT step (Table 28). The VOL is then set to the same value for both channels.

When ZELMN bit = “0” (zero cross detection is enabled), the VOL value is changed by ALC limiter operation at the individual zero crossing points of L channel and R channel, or at the zero crossing timeout. ZTM1-0 bits set the zero crossing timeout period of both ALC limiter and recovery operation (Table 29). When ALC output level exceeds full-scale at LFST bit = “1”, VOL values are immediately (Period: 1/fs) changed in 1step(L/R common). When ALC output level is less than full-scale, VOL values are changed at the individual zero crossing point of each channels or at the zero crossing timeout.

When ZELMN bit = “1” (zero cross detection is disabled), VOL value is immediately (period: 1/fs) changed by ALC limiter operation. Attenuation step is fixed to 1 step regardless of the setting of LMAT1-0 bits.

After completing the attenuate operation, unless ALC bit is changed to “0”, the operation repeats when the input signal level exceeds ALC limiter detection level.

LMTH1 bit	LMTH0 bit	ALC Limiter Detection Level	ALC Recovery Counter Reset Level	(default)
0	0	ALC Output $\geq -2.5\text{dBFS}$	$-2.5\text{dBFS} > \text{ALC Output} \geq -4.1\text{dBFS}$	(default)
0	1	ALC Output $\geq -4.1\text{dBFS}$	$-4.1\text{dBFS} > \text{ALC Output} \geq -6.0\text{dBFS}$	
1	0	ALC Output $\geq -6.0\text{dBFS}$	$-6.0\text{dBFS} > \text{ALC Output} \geq -8.5\text{dBFS}$	
1	1	ALC Output $\geq -8.5\text{dBFS}$	$-8.5\text{dBFS} > \text{ALC Output} \geq -12\text{dBFS}$	

Table 27. ALC Limiter Detection Level/ Recovery Counter Reset Level

LMAT1 bit	LMAT0 bit	ALC1 Limiter ATT Step				(default)
		ALC1 Output $\geq \text{LMTH}$	ALC1 Output $\geq \text{FS}$	ALC1 Output $\geq \text{FS} + 6\text{dB}$	ALC1 Output $\geq \text{FS} + 12\text{dB}$	
0	0	1	1	1	1	(default)
0	1	2	2	2	2	
1	0	2	4	4	8	
1	1	1	2	4	8	

Table 28. ALC Limiter ATT Step

ZTM1 bit	ZTM0 bit	Zero Cross Time Out				(default)
			8kHz	16kHz	48kHz	
0	0	128/fs	16ms	8ms	2.7ms	(default)
0	1	256/fs	32ms	16ms	5.3ms	
1	0	512/fs	64ms	32ms	10.7ms	
1	1	1024/fs	128ms	64ms	21.3ms	

Table 29. ALC Zero Crossing Timeout Period

2. ALC Recovery Operation

ALC recovery operation wait for the WTM2-0 bits (Table 30) to be set after completing ALC limiter operation. If the input signal does not exceed “ALC recovery waiting counter reset level” (Table 27) during the wait time, ALC recovery operation is executed. The VOL value is automatically incremented by RGAIN1-0 bits (Table 31) up to the set reference level (Table 32) with zero crossing detection which timeout period is set by ZTM1-0 bits (Table 29). The ALC recovery operation is executed in a period set by WTM2-0 bits. If the setting of ZTM1-0 bits is longer than WTM2-0 bits and no zero crossing occurs, the ALC recovery operation is executed at a period set by ZTM1-0 bits.

For example, when the current VOL value is 30H and RGAIN1-0 bits are set to “01”, VOL is changed to 32H by auto limiter operation and then the input signal level is gained by 0.75dB (=0.375dB x 2). When the VOL value exceeds the reference level (REF7-0), the VOL values are not increased.

When

“ALC recovery waiting counter reset level (LMTH1-0) ≤ Output Signal < ALC limiter detection level (LMTH1-0)” during the ALC recovery operation, the waiting timer of ALC recovery operation is reset. When

“ALC recovery waiting counter reset level (LMTH1-0) > Output Signal”, the waiting timer of ALC recovery operation starts.

ALC operations correspond to the impulse noise. When the impulse noise is input, the ALC recovery operation becomes faster than a normal recovery operation. When large noise is input to a microphone instantaneously, the quality of small level in the large noise can be improved by this fast recovery operation. The speed of first recovery operation is set by RFST1-0 bits (Table 34). The fast recovery operation is not executed when FRN bit = “1” even if an impulse noise is input.

WTM2 bit	WTM1 bit	WTM0 bit	ALC Recovery Operation Waiting Period			(default)
			8kHz	16kHz	48kHz	
0	0	0	128/fs	16ms	8ms	2.7ms
0	0	1	256/fs	32ms	16ms	5.3ms
0	1	0	512/fs	64ms	32ms	10.7ms
0	1	1	1024/fs	128ms	64ms	21.3ms
1	0	0	2048/fs	256ms	128ms	42.7ms
1	0	1	4096/fs	512ms	256ms	85.3ms
1	1	0	8192/fs	1024ms	512ms	170.7ms
1	1	1	16384/fs	2048ms	1024ms	341.3ms

Table 30. ALC Recovery Operation Waiting Period

RGAIN1 bit	RGAIN0 bit	GAIN STEP		(default)
0	0	1 step	0.375dB	
0	1	2 step	0.750dB	
1	0	3 step	1.125dB	
1	1	4 step	1.500dB	

Table 31. ALC Recovery Gain Step

IREF7-0 bits	GAIN (dB)	Step
F1H	+36.0	0.375dB (default)
F0H	+35.625	
EFH	+35.25	
:	:	
E1H	+30.0	
:	:	
92H	+0.375	
91H	0.0	
90H	-0.375	
:	:	
2H	-53.625	
1H	-54.0	
0H	MUTE	

Table 32. Reference Level of ALC Recovery Operation for Recoding

OREF5-0 bits	GAIN (dB)	Step
3CH	+36.0	1.5dB (default)
3BH	+34.5	
3AH	+33.0	
:	:	
28H	+6.0	
:	:	
25H	+1.5	
24H	0.0	
23H	-1.5	
:	:	
2H	-51.0	
1H	-52.5	
0H	-54.0	

Table 33. Reference Level of ALC Recovery Operation for Playback

RFST1 bit	RFST0 bit	Recovery Speed
0	0	Double
0	1	Quad
1	0	8times
1	1	16times

Table 34. Fast Recovery Speed Setting (FRN bit = "0")

3. The Volume at ALC Operation

The volume value during ALC operation is reflected in VOL7-0 bits. It is possible to check the current volume by reading the register value of VOL7-0 bits. This function is only enabled in 3-wire control mode (I2C pin = "L").

VOL7-0 bits	GAIN (dB)
F1H	+36.0
F0H	+35.625
EFH	+35.25
:	:
C5H	+19.5
:	:
92H	+0.375
91H	0.0
90H	-0.375
:	:
2H	-53.625
1H	-54.0
0H	MUTE

Table 35. Value of VOL7-0 bits

4. Example of ALC Setting

Table 36 and Table 37 show the examples of the ALC setting for recording and playback path.

Register Name	Comment	fs=8kHz		fs=48kHz	
		Data	Operation	Data	Operation
LMTH1-0	Limiter detection Level	01	-4.1dBFS	01	-4.1dBFS
ZELMN	Limiter zero crossing detection	0	Enable	0	Enable
FRN	Fast Recovery mode	0	Enable	0	Enable
ZTM1-0	Zero crossing timeout period	01	32ms	11	21.3ms
WTM2-0	Recovery waiting period *WTM2-0 bits should be the same value or larger value than ZTM1-0 bits	001	32ms	100	42.7ms
IREF7-0	Maximum gain at recovery operation	E1H	+30dB	E1H	+30dB
IVL7-0, IVR7-0	Gain of IVOL	E1H	+30dB	E1H	+30dB
LMAT1-0	Limiter ATT step	00	1 step	00	1 step
LFST	Fast Limiter Operation	1	ON	1	ON
RGAIN1-0	Recovery GAIN step	00	1 step	00	1 step
RFST1-0	Fast Recovery Speed	01	4 times	01	4 times
ALC1	ALC1 enable	1	Enable	1	Enable

Table 36. Example of the ALC Setting (Recording)

Register Name	Comment	fs=8kHz		fs=48kHz	
		Data	Operation	Data	Operation
LMTH1-0	Limiter detection Level	01	-4.1dBFS	01	-4.1dBFS
ZELMN	Limiter zero crossing detection	0	Enable	0	Enable
FRN	Fast Recovery mode	0	Enable	0	Enable
ZTM1-0	Zero crossing timeout period	01	32ms	11	21.3ms
WTM2-0	Recovery waiting period *WTM2-0 bits should be the same value or larger value than ZTM1-0 bits	001	32ms	100	42.7ms
OREF5-0	Maximum gain at recovery operation	28H	+6dB	28H	+6dB
OVL7-0, OVR7-0	Gain of VOL	91H	0dB	91H	0dB
LMAT1-0	Limiter ATT step	00	1 step	00	1 step
LFST	Fast Limiter Operation	1	ON	1	ON
RGAIN1-0	Recovery GAIN step	00	1 step	00	1 step
RFST1-0	Fast Recovery Speed	01	4 times	01	4 times
ALC2	ALC2 enable	1	Enable	1	Enable

Table 37. Example of the ALC Setting (Playback)

5. Example of registers set-up sequence of ALC Operation

The following registers must not be changed during ALC operation. These bits must be changed after ALC operation is stopped by ALC1 bit = ALC2 bit= "0". ALC output is "0" data until the AK4955 becomes manual mode after writing "0" to ALC1 and ALC2 bits.

LMTH1-0, LMAT1-0, WTM2-0, ZTM1-0, RGAIN 1-0, REF7-0, ZELMN, RFST1-0, LFST, FRN bits

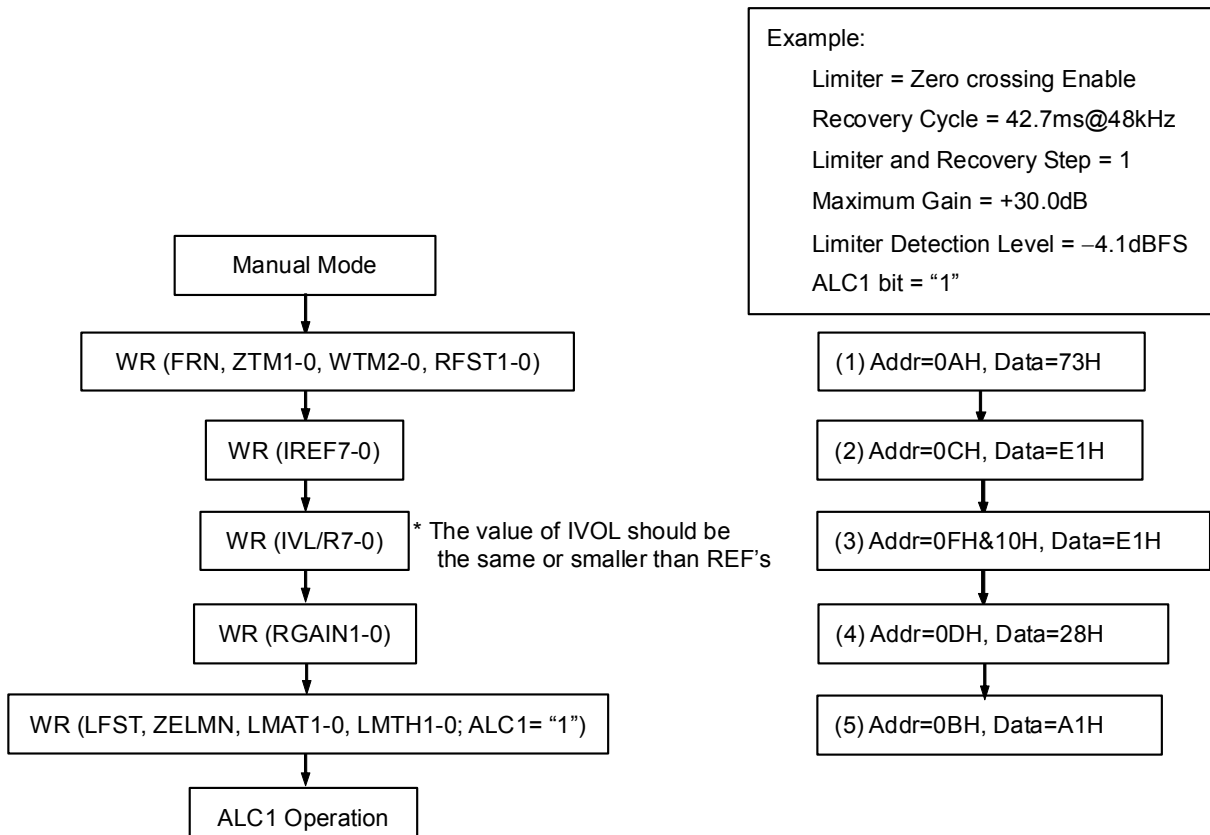

Figure 43. Registers Set-up Sequence at ALC1 Operation (recording path)

■ Input Digital Volume (Manual Mode)

The input digital volume becomes manual mode when ALC1 bit is set to “0” while ADCPF bit is “1”. This mode is used in the cases shown below.

1. After exiting reset state, when setting up the registers for ALC operation (ZTM1-0, LMTH and etc.)
2. When the registers for ALC operation (Limiter period, Recovery period and etc.) are changed.
For example; when the sampling frequency is changed.
3. When IVOL is used as a manual volume control.

IVL7-0 and IVR7-0 bits set the gain of the volume control (Table 38). The IVOL value is changed at zero crossing or timeout. The zero crossing timeout period is set by ZTM1-0 bits. Lch and Rch volumes are set individually by IVL7-0 and IVR7-0 bits when IVOLC bit = “0”. IVL7-0 bits control both Lch and Rch volumes together when IVOLC bit = “1”. When changing the volume, zero cross detection is executed on both Lch and Rch independently.

IVL7-0 bits IVR7-0 bits	GAIN (dB)	Step
F1H	+36.0	0.375dB (default)
F0H	+35.625	
EFH	+35.25	
:	:	
E2H	+30.375	
E1H	+30.0	
E0H	+29.625	
:	:	
03H	-53.25	
02H	-53.625	
01H	-54	
00H	MUTE	

Table 38. Input Digital Volume Setting

If IVL7-0 or IVR7-0 bits is written during PMPFIL bit = “0”, IVOL operation starts with the written values after PMPFIL bit is changed to “1”.

When writing to IVOL7-0 bits continually, take an interval of zero crossing timeout period or more. If not, the zero crossing counters are reset at each time and the volume will not be changed. However, when writing the same register values as the previous time, the zero crossing counters will not be reset, so that it could be written in an interval less than zero crossing timeout.

■ De-emphasis Filter

A digital de-emphasis filter is available for 32kHz, 44.1kHz or 48kHz sampling rates ($t_c = 50/15\mu s$) by IIR filter and it is controlled by DEM1-0 bits. These bits select the input frequency for the filtering. (Table 39)

DEM1 bit	DEM0 bit	Mode
0	0	44.1kHz
0	1	OFF
1	0	48kHz
1	1	32kHz

(default)

Table 39. De-emphasis Filter Control

■ Output Digital Volume (Manual Mode)

The ALC block becomes output digital volume (manual mode) by setting ALC2 bit to “0” when PMPFIL = PMDAC bits = “1” and ADCPF bit is “0”. The output digital volume gain is set by the OVL7-0 bit and the OVR7-0 bits (Table 40). When the OVOLC bit = “1”, the OVL7-0 bits control both L and R channel volume levels. When the OVOLC bit = “0”, the OVL7-0 bits control L channel volume level and the OVR7-0 bits control R channel volume level. When changing the volumes, zero cross detection is executed on both L and R channels independently. The OVOL value is changed at zero crossing or timeout. The zero crossing timeout period is set by ZTM1-0 bits.

OVL7-0 bits OVR7-0 bits	GAIN [dB]	Step
F1H	+36.0	0.375dB
F0H	+35.625	
EFH	+35.25	
:	:	
92H	+0.375	
91H	0.0	
90H	-0.375	
:	:	
2H	-53.625	
1H	-54.0	
0H	MUTE	

(default)

Table 40. Output Digital Volume Setting

When writing to the OVL7-0 bits and OVR7-0 bits continuously, the control register should be written in an interval more than zero crossing timeout. If not, the zero crossing counters are reset at each time and the volume will not be changed. However, when writing the same register values as the previous time, the zero crossing counter will not be reset, so that it could be written in an interval less than zero crossing timeout.

■ Output Digital Volume 2

The AK4955 has a digital output volume (256 levels, 0.5dB step, Mute). The volume is included in front of a DAC block. The input data of DAC is changed from +12 to -115dB or MUTE. When DVOLC bit = "1", the DVL7-0 bits control both Lch and Rch volume levels together. When DVOLC bit = "0", Lch and Rch volume levels can be controlled independently by DVL7-0 bits and DVR7-0 bits. This volume has soft transition function. Therefore no switching noise occurs during the transition. The DVTM bit set the transition time between set values of DVL7-0 and DVR7-0 bits (from 00H to FFH) as either 256/fs or 1024/fs (Table 42). When DVTM bit = "0", it takes 1024/fs (21.3ms@fs=48kHz) from 00H (+12dB) to FFH (MUTE).

DVL7-0 bits DVR7-0 bits	Gain	Step
00H	+12.0dB	0.5dB (default)
01H	+11.5dB	
02H	+11.0dB	
⋮	⋮	
18H	0dB	
⋮	⋮	
FDH	-114.5dB	
FEH	-115.0dB	
FFH	Mute ($-\infty$)	

Table 41. Output Digital Volume2 Setting

DVTM bit	Transition Time between DVL/R7-0 bits = 00H and FFH		
	Setting	fs=8kHz	fs=48kHz
0	1024/fs	128ms	21.3ms
1	256/fs	32ms	5.3ms

Table 42. Transition Time Setting of Output Digital Volume2

■ Soft Mute

Soft mute operation is performed in the digital domain. When the SMUTE bit is set “1”, the output signal is attenuated by $-\infty$ (“0”) during the cycle set by DVTM bit. When the SMUTE bit is returned to “0”, the mute is cancelled and the output attenuation gradually changes to the value set by DVL/R7-0 bits from $-\infty$ during the cycle set by DVTM bit. If the soft mute is cancelled within the cycle set by DVTM bit after starting the operation, the attenuation is discontinued and returned to the level set by DVL/R7-0 bits.

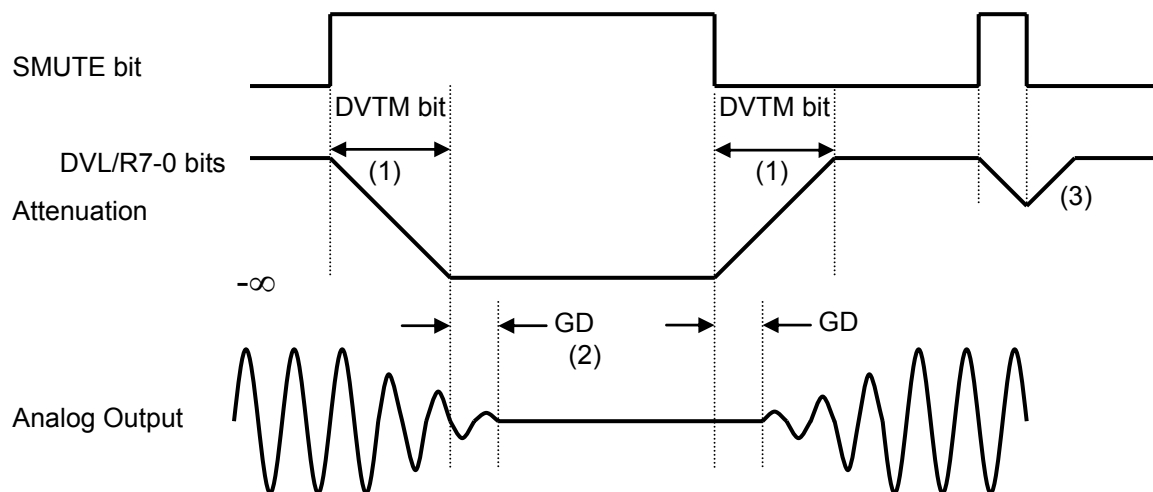

Figure 44. Soft Mute Function

- (1) The input signal is attenuated to $-\infty$ (“0”) in the cycle set by DVTM bit.
- (2) Analog output corresponding to digital input has group delay (GD).
- (3) If soft mute is cancelled before attenuating to $-\infty$, the attenuation is discontinued and returned to the level set by DVL/R7-0 bits within the same cycle.

■ Mono Input and BEEP Generation Circuit

The AK4955 has the MIN pin for external signal input and a BEEP generation circuit. BPM1-0 bits control BEEP mode.

BPM1 bit	BPM0 bit	BEEP Mode	
0	0	MIN pin (Internal Resistance mode)	(default)
0	1	MIN pin (External Resistance mode)	
1	0	BEEP Generator mode	
1	1	N/A	

Table 43. BEEP Mode Setting (N/A: Not available)

1. Mono Input (MIN) pin (BPM1-0 bits = “00” or “01”)

When BPM1-0 bits = “00” or “01”, the input signal to the MIN pin is output from the speaker amplifier by setting BEEPS bit to “1”, and it is output from the stereo lineout amplifier by setting BEEPL bit to “1”. BPVCM bit sets the common voltage of MIN input amplifier. (Table 44) When BPVCM bit = “1”, maximum value is AVDD Vpp. Set BEEP GAIN (BPLVL3-0 bits) to keep MIN-Amp output amplitude less than 0.1Vpp.

BPVCM bit	MIN-Amp Common Voltage (typ)	
0	1.15V	(default)
1	1.65V	

Table 44. Common Potential Setting of MIN-Amp

• Internal Resistance Mode (BPM1-0 bits = “00”)

Input BEEP gain is controlled by BPLVL3-0 bits (Table 45). In this case an external resistor R_i is not necessary.

BPLVL3 bit	BPLVL2 bit	BPLVL1 bit	BPLVL0 bit	BEEP Gain	
0	0	0	0	0dB	(default)
0	0	0	1	-6dB	
0	0	1	0	-12dB	
0	0	1	1	-18dB	
0	1	0	0	-24dB	
0	1	0	1	-30dB	
0	1	1	0	-33dB	
0	1	1	1	-36dB	
1	0	0	0	-39dB	
1	0	0	1	-42dB	

Table 45. BEEP Output Gain Setting when BPM1-0 bits = “00”

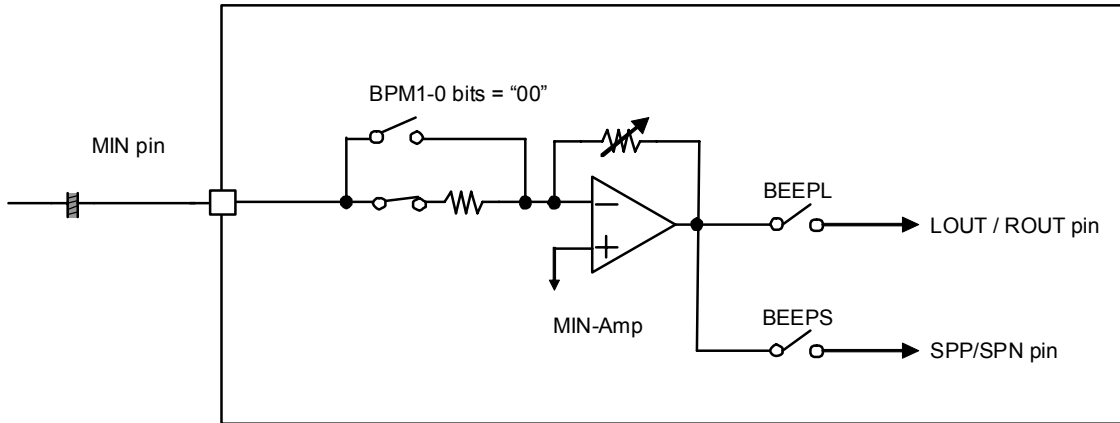

Figure 45. Block Diagram of MIN pin (BPM1-0 bits = "00")

• External Resistance Mode (BPM1-0 bit = "01")

Gain setting of input BEEP signal is controlled by an external resistor R_i . The gain is in inverse proportion to the R_i value. (Figure 46) Gain setting by BPLVL3-0 bits is not available.

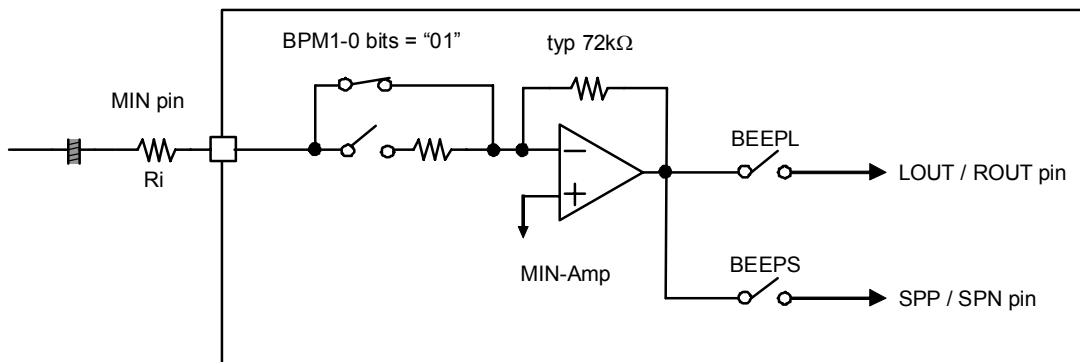

Figure 46. Block Diagram of MIN pin (BPM1-0 bits = "01")

SPKG1-0 bits	MIN → SPP/SPN Gain		(default)
	ALC2 bit = "0"	ALC2 bit = "1"	
00	+6.1dB	+8.1dB	
01	+8.1dB	+10.1dB	
10	+10.1dB	+12.1dB	
11	+12.1dB	+14.1dB	

Table 46. MIN → SPK Output Gain

LVC1-0 bits	MIN → Lineout Gain
00	-1.34dB
01	0dB
10	+2.50dB
11	+3.52dB

Table 47. MIN → Lineout Gain (x: Don't care)

2. BEEP Generation Circuit (BPM1-0 bits = "10")

The AK4955 integrates a BEPP generation circuit. When PMSPK bit = "1", the speaker amplifier outputs BEEP signal by setting PMBPG=BEEPS bits = "1", and the Stereo lineout amplifier outputs BEEP signal by setting PMBPG=BEEPL bit = "1" when PMLO bit = "1".

After outputting the signal during the time set by BPON7-0 bits, the AK4955 stops the output signal during the time set by BPOFF7-0 bits (Figure 47). The repeat count is set by BPTM6-0 bits, and the output level is set by BPLVL3-0 bits. When BPCNT bit is "0", if BPOUT bit is written "1", the AK4955 outputs the beep for the times of repeat count. When the output is finished, BPOUT bit is set to "0" automatically. When BPCNT bit is set to "1", the AK4955 outputs the beep in succession regardless of repeat count, on-time and off-time. The output frequency is set by BPF1-0 bits.

< Setting parameter >

- 1) Output Frequency (Table 48, Table 49)
- 2) ON Time (Table 51, Table 52)
- 3) OFF Time (Table 53, Table 54)
- 4) Repeat Count (Table 55)
- 5) Output Level (Table 56)

- BPF1-0, BPON7-0, BPOFF7-0, BPTM6-0 and BPLVL3-0 bits should be set when BPOUT =BPCNT bits = "0".
- BPCNT bit is given priority in BPOUT bit. When BPOUT bit is "1", BPOUT bit is set to "0" forcibly by setting BPCNT bit to "0".
- In the case that BEEP is output by BPCNT bit = "1", after stopping the BEEP outputs by changing BPCNT bit to "0", writings to BPOUT bit and BPCNT bit are inhibited for 10ms. In the case that BEEP is output by BPCNT bit = "0", after changing BPCNT bit to "0" or BEEP output is finished (ON/OFF time and repeat setting time), writings to BPOUT bit and BPCNT bit are inhibited for 10ms.

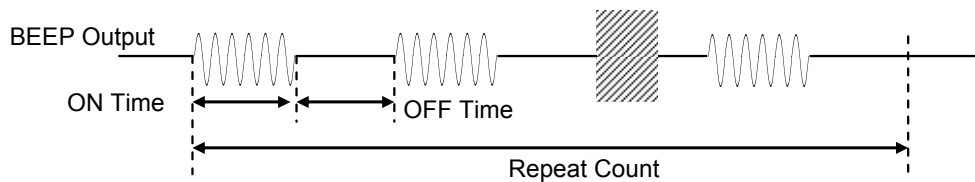

Figure 47. BEEP Output

BPFR1-0 bits	Output frequency of BEEP Generator [Hz]	
	fs = 48kHz (Note 46)	fs = 44.1kHz (Note 47)
00	4000	4009
01	2000	2005
10	1297	1297
11	800	802

(default)

Note 46. The sampling frequency is 8kHz, 16kHz, 32kHz, or 48kHz.

Note 47. The sampling frequency is 11.025kHz, 22.05kHz, or 44.1kHz.

Table 48. Beep Output Frequency (MCKI Reference, PLL Master/Slave Mode)

BPFR1-0 bits	Output frequency of BEEP Generator [Hz]		
	FS3-2 bits = "00"	FS3-2 bits = "01"	FS3-2 bits = "10"
00	fs/2.75	fs/5.5	fs/11
01	fs/5.5	fs/11	fs/22
10	fs/8.5	fs/17	fs/34
11	fs/13.75	fs/27.5	fs/55

(default)

Table 49. Beep Output Frequency (BICK Reference, PLL Slave Mode)

BPFR1-0 bits	Output frequency of BEEP Generator [Hz]			
	FS1-0 bits = "00"	FS1-0 bits = "01"	FS1-0 bits = "10"	FS1-0 bits = "11"
00	fs/11	fs/2.75	fs/5.5	fs/11
01	fs/22	fs/5.5	fs/11	fs/22
10	fs/34	fs/8.5	fs/17	fs/34
11	fs/55	fs/13.75	fs/27.5	fs/55

(default)

Table 50. Beep Output Frequency (EXT Master/Slave Mode)

BPON7-0 bits	ON Time of BEEP Generator [msec]		Step[msec]	
	fs=48kHz (Note 46)	fs=44.1kHz (Note 47)	fs=48kHz (Note 46)	fs=44.1kHz (Note 47)
0H	8.0	7.98	8.0	7.98
1H	16.0	15.86		
2H	24.0	23.95		
3H	32.0	31.93		
:	:	:		
FDH	2032	2027.3		
FEH	2040	2035.3		
FFH	2048	2043.4		

(default)

Note 46. The sampling frequency is 8kHz, 16kHz, 32kHz, or 48kHz

Note 47. The sampling frequency is 11.025kHz, 22.05kHz, or 44.1kHz

Table 51. Beep Output On Time (MCKI Reference, PLL Master/Slave Mode)

BPON7-0 bits	ON Time of BEEP Generator [msec]		Step[msec]		
	fs=48kHz (Note 46)	fs=44.1kHz (Note 47)	fs=48kHz (Note 46)	fs=44.1kHz (Note 47)	
0H	7.33	7.98	7.33	7.98	(default)
1H	14.67	15.86			
2H	22.00	23.95			
3H	29.33	31.93			
:	:	:			
FDH	1862.6	2027.3			
FEH	1970.0	2035.3			
FFH	1877.3	2043.4			

Note 46. The sampling frequency is 8kHz, 16kHz, 32kHz, or 48kHz

Note 47. The sampling frequency is 11.025kHz, 22.05kHz, or 44.1kHz

Table 52. BEEP Output ON Time (BICK Reference, PLL Slave Mode, EXT Master/Slave Mode)

BPOFF7-0 bits	OFF Time of BEEP Generator [msec]		Step[msec]		
	fs=48kHz (Note 46)	fs=44.1kHz (Note 47)	fs=48kHz (Note 46)	fs=44.1kHz (Note 47)	
0H	8.0	7.98	8.0	7.98	(default)
1H	16.0	15.86			
2H	24.0	23.95			
3H	32.0	31.93			
:	:	:			
FDH	2032	2027.3			
FEH	2040	2035.3			
FFH	2048	2043.4			

Note 46. The sampling frequency is 8kHz, 16kHz, 32kHz, or 48kHz

Note 47. The sampling frequency is 11.025kHz, 22.05kHz, or 44.1kHz

Table 53. BEEP Output OFF Time (MCKI Reference, PLL Master/Slave Mode)

BPOFF7-0 bits	OFF Time of BEEP Generator [msec]		Step[msec]		
	fs=48kHz (Note 46)	fs=44.1kHz (Note 47)	fs=48kHz (Note 46)	fs=44.1kHz (Note 47)	
0H	7.33	7.98	7.33	7.98	(default)
1H	14.67	15.86			
2H	22.00	23.95			
3H	29.33	31.93			
:	:	:			
FDH	1862.6	2027.3			
FEH	1970.0	2035.3			
FFH	1877.3	2043.4			

Note 46. The sampling frequency is 8kHz, 16kHz, 32kHz, or 48kHz

Note 47. The sampling frequency is 11.025kHz, 22.05kHz, or 44.1kHz

Table 54. BEEP Output OFF Time (BICK Reference, PLL Slave Mode, EXT Master/Slave Mode)

BPTM6-0 bits	Repeat Count
0H	1
1H	2
2H	3
:	:
7DH	126
7EH	127
7FH	128

(default)

Table 55. BEEP Output Repeat Count

BPLVL3 bit	BPLVL2 bit	BPLVL1 bit	BPLVL0 bit	BEEP Gain
0	0	0	0	0dB
0	0	0	1	-6dB
0	0	1	0	-12dB
0	0	1	1	-18dB
0	1	0	0	-24dB
0	1	0	1	-30dB
0	1	1	0	-33dB
0	1	1	1	-36dB
1	0	0	0	-39dB
1	0	0	1	-42dB

(default)

Note 48. When the BEEP gain is set to 0dB, BEEP output amplitude is 2.3Vpp at lineout and 3.0Vpp at SPK-amp with 8Ω (SPKG1-0 bits = "00").

Table 56. BEEP Output Level

■ Stereo Line Output (LOUT, ROUT pin)

When DACL bit is set to “1”, L and R channel signals of DAC are output in single-ended format via LOUT and ROUT pins. When DACL bit is “0”, output signals are muted and LOUT and ROUT pins output common voltage. The load impedance is 10kΩ (min.). When the PMLO bit = LOPS bit = “0”, the stereo line output enters power-down mode and the output is pulled-down to VSS1 by 100kΩ(typ). When the LOPS bit is “1”, stereo line output enters power-save mode. Pop noise at power-up/down can be reduced by changing PMLO bit when LOPS bit = “1”. In this case, output signal line should be pulled-down by 20kΩ after AC coupled as Figure 49. Rise/Fall time is 300ms (max) when C=1μF and R_L=10kΩ. When PMLO bit = “1” and LOPS bit = “0”, stereo line output is in normal operation.

LVCM1-0 bits set the gain of stereo line output.

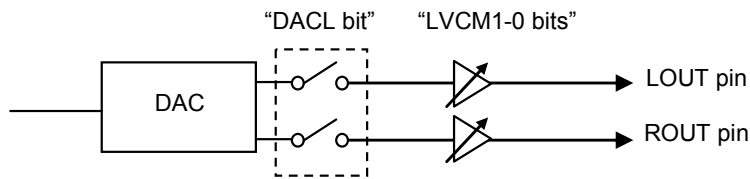

Figure 48. Stereo Line Output

LOPS bit	PMLO bit	Mode	LOUT/ROUT pin
0	0	Power Down	Pull-down to VSS1
	1	Normal Operation	Normal Operation
1	0	Power Save	Fall down to VSS1
	1	Power Save	Rise up to Common Voltage

(default)

Table 57. Stereo Line Output Mode Select

LVCM1-0 bits	LVDD	Gain
00	2.7 ~ 5.5 V	-1.34dB
01	3.0 ~ 5.5 V	0dB
10	4.0 ~ 5.5 V	+2.50dB
11	4.5 ~ 5.5V	+3.52dB

(default)

Table 58. Stereo Lineout Volume Setting

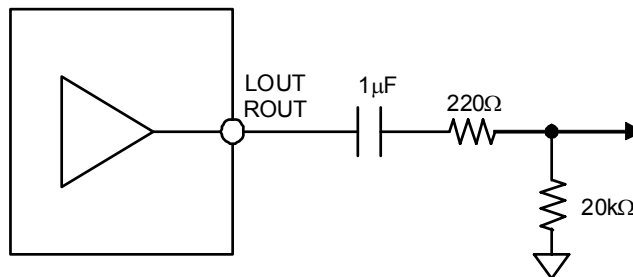

Figure 49. External Circuit for Stereo Line Output (in case of using a Pop Noise Reduction Circuit)

[Stereo Line Output Control Sequence (in case of using a Pop Noise Reduction Circuit)]

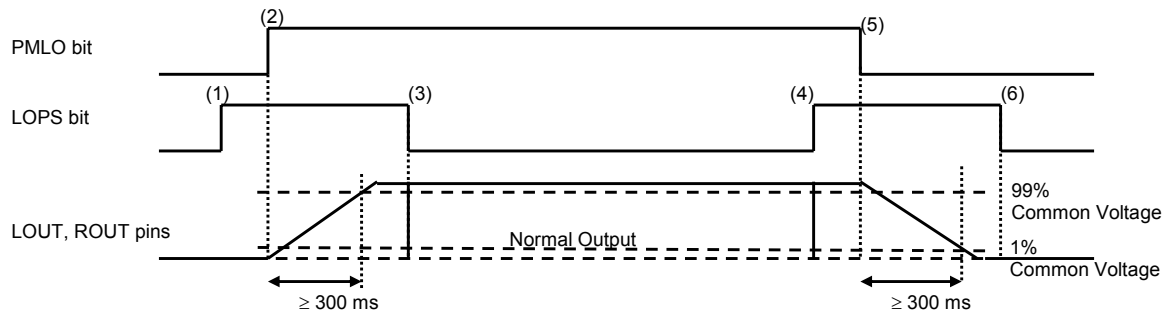

Figure 50. Stereo Line Output Control Sequence (in case of using a Pop Noise Reduction Circuit)

- (1) Set LOPS bit = “1”. Stereo line output enters power-save mode.
- (2) Set PMLO bit = “1”. Stereo line output exits power-down mode.
LOUT and ROUT pins rise up to common voltage. Rise time is 200ms (max 300ms) when C=1μF.
- (3) Set LOPS bit = “0” after LOUT and ROUT pins rise up. Stereo line output exits power-save mode.
Stereo line output is enabled.
- (4) Set LOPS bit = “1”. Stereo line output enters power-save mode.
- (5) Set PMLO bit = “0”. Stereo line output enters power-down mode.
LOUT and ROUT pins fall down to 1% of the common voltage. Fall time is 200ms (max 300ms) at C=1μF.
- (6) Set LOPS bit = “0” after LOUT and ROUT pins fall down. Stereo line output exits power-save mode.

< Mono Mixing Output >

Mono mixing outputs are available by setting MONO1-0 bits. Inputted digital data from the SDTI pin can be converted to mono signal [(L+R)/2] and are output via LOUT and ROUT pins. (Figure 34)

MONO1 bit	MONO0 bit	LOUT pin	ROUT pin
0	0	Lch	Rch
0	1	Lch	Lch
1	0	Rch	Rch
1	1	(Lch+Rch)/2	(Lch+Rch)/2

(default)

Table 59. Output Data Select via LOUT/ROUT pin

■ Speaker Output

The DAC output signal is input to the speaker amplifier as mono signal [(L+R)/2]. The speaker amplifier has mono output as it is BLT (Bridged Transless) capable. The gain and output level are set by SPKG1-0 bits. The output level is depends on AVDD and SPKG1-0 bits setting.

SPKG1-0 bits	Gain	
	ALC bit = "0"	ALC bit = "1"
00	+6.1dB	+8.1dB
01	+8.1dB	+10.1dB
10	+10.1dB	+12.1dB
11	+12.1dB	+14.1dB

(default)

Table 60. SPK-Amp Gain

SVDD	SPKG1-0 bits	SPK-Amp Output (DAC Input =0dBFS)	
		ALC bit = "0"	ALC bit = "1" (LMTH1-0 bits = "00")
3.3V	00	3.37Vpp	3.17Vpp
	01	4.23Vpp (Note 49)	4.00Vpp
	10	5.33Vpp (Note 49)	5.04Vpp (Note 49)
	11	6.71Vpp (Note 49)	6.33Vpp (Note 49)
4.8V	00	3.37Vpp	3.17Vpp
	01	4.23Vpp	4.00Vpp
	10	5.33Vpp	5.04Vpp
	11	6.71Vpp (Note 49)	6.33Vpp (Note 49)

Note 49. The output level is calculated on the assumption that the signal is not clipped. However, in the actual case, the SPK-Amp output signal is clipped when DAC outputs 0dBFS signal. The SPK-Amp output level should be kept under 4.0Vpp (AVDD=3.3V) or 6.0Vpp (SVDD=4.8V) by adjusting digital volume to prevent clipped noise.

Table 61. SPK-Amp Output Level

< Speaker-Amp Control Sequence >

The speaker amplifier is powered-up/down by PMSPK bit. When PMSPK bit is “0”, both SPP and SPN pins are in Hi-Z state. When PMSPK bit is “1” and SPPSN bit is “0”, the speaker amplifier enters power-save mode. In this mode, the SPP pin is placed in Hi-Z state and the SPN pin outputs SVDD/2 voltage.

When the PMSPK bit is “1” after the PDN pin is changed from “L” to “H”, the SPP and SPN pins rise up in power-save mode. In this mode, the SPP pin is placed in a Hi-Z state and the SPN pin goes to SVDD/2 voltage. Because the SPP and SPN pins rise up in power-save mode, pop noise can be reduced. When the AK4955 is powered-down (PMSPK bit = “0”), pop noise can also be reduced by first entering power-save-mode.

PMSPK bit	SPPSN bit	Mode	SPP pin	SPN pin
0	x	Power-down	Hi-Z	Hi-Z
1	0	Power-save	Hi-Z	SVDD/2
	1	Normal Operation	Normal Operation	Normal Operation

(default)

Table 62 Speaker-Amp Mode Setting (x: Don't care)

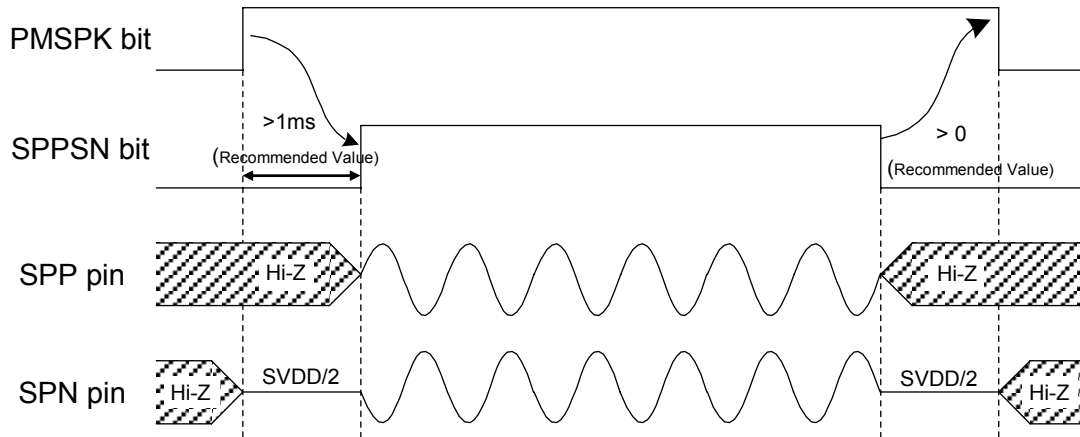

Figure 51. Power-up/Power-down Timing for Speaker-Amp

■ Thermal Shutdown Function

When the internal temperature of the device rises up irregularly (e.g. when output pins are shortened), the thermal shutdown is executed, all blocks except VCOM and LDO blocks are powered-down, and THDET bit becomes “1”. These blocks will not return to normal operation until being reset by the PDN pin. The thermal shutdown status can be monitored by reading THDET bit. THDET bit becomes “0” by this PDN pin reset.

■ Video Block

The integrated cap-less video amplifier with a charge pump has drivability for a load resistance of 150Ω (Figure 52). The AK4955 has a composite input and output. A Low Pass Filter (LPF) and Gain Control Amp are integrated, and VG1-0 bits set the gain (+6/+9/+12/+16.5 dB) (Table 63). The integrated charge pump circuit supplies a negative power to the video amplifier, and the video amplifier outputs 0V video signal as pedestal level. The video amplifier power management is controlled by PMV bit, and the charge pump circuit power management is controlled by PMCP bit. When PMV bit = “0”, the VOUT pin outputs 0V. The video inputs must be C-coupled by a 0.1μF capacitor. The video signal source impedance at transmitting side must be less than or equal to 600Ω.

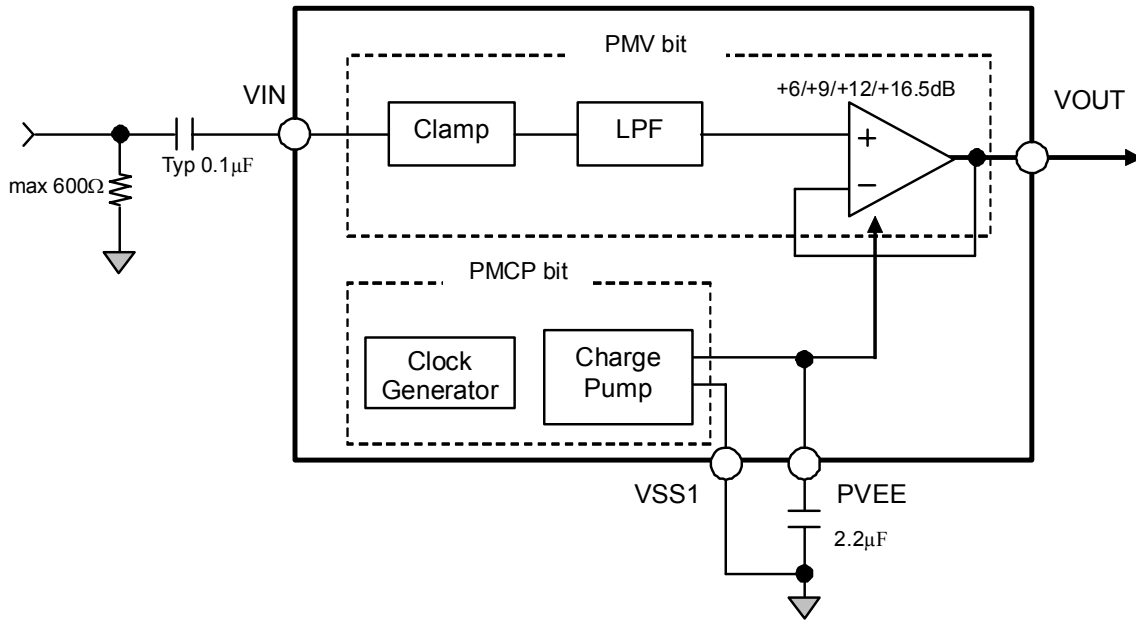

Figure 52. Video Block Diagram

VG1-0 bits	GAIN
00	+6dB
01	+9dB
10	+12dB
11	+16.5dB

(default)

Table 63. Video Signal Gain Setting

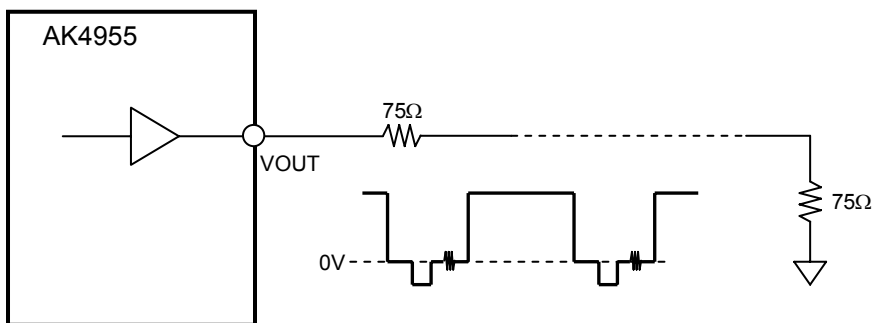

Figure 53. Video Signal Output

■ Regulator Block

The AK4955 integrates a regulator. The 3.3V (typ) power supply voltage from the AVDD pin is converted to 2.3V (typ) by the regulator and supplied to the analog blocks (MIC-Amp, ADC, DAC, MIN, Video-Amp). The regulator is powered up by PMVCM bit = "1", and powered down by PMVCM = "0". Connect a 2.2μF (± 50%) capacitor to the REGFIL pin to reduce noise on AVDD.

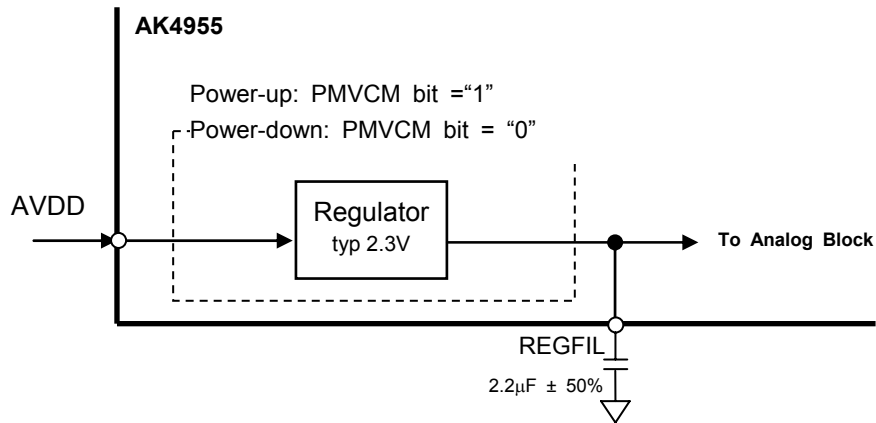

Figure 54 Regulator Block

■ Serial Control Interface

(1) 3-wire Serial Control Mode (00H ~ 4FH)

1. Data Writing and Reading Modes on Every Address (00H~4FH)

One data is written to (read from) one address.

Internal registers may be written by using 3-wire serial interface pins (CSN, CCLK and CDTIO). The data on this interface consists of Read/Write, Register address (MSB first, 7bits) and Control data or Output data (MSB first, 8bits). Address and data is clocked in on the rising edge of CCLK and data is clocked out on the falling edge. Data writings become available on the rising edge of CSN. When reading the data, the CDTIO pin changes to output mode at the falling edge of 8th CCLK and outputs data in D7-D0. However this reading function is available only when READ bit = “1”. When READ bit = “0”, the CDTIO pin stays as Hi-Z even after the falling edge of 8th CCLK. The data output finishes on the rising edge of CSN. The CDTIO is placed in a Hi-Z state except when outputting the data at read operation mode. Clock speed of CCLK is 12.5MHz (max) when writing and 6.75MHz (max) when reading. The value of internal registers are initialized by the PDN pin = “L”.

Note 50. Data reading is only available on the following addresses; 00 ~ 4FH and 50H ~ 6FH. When reading address 50H ~ 6FH, the register values are invalid.

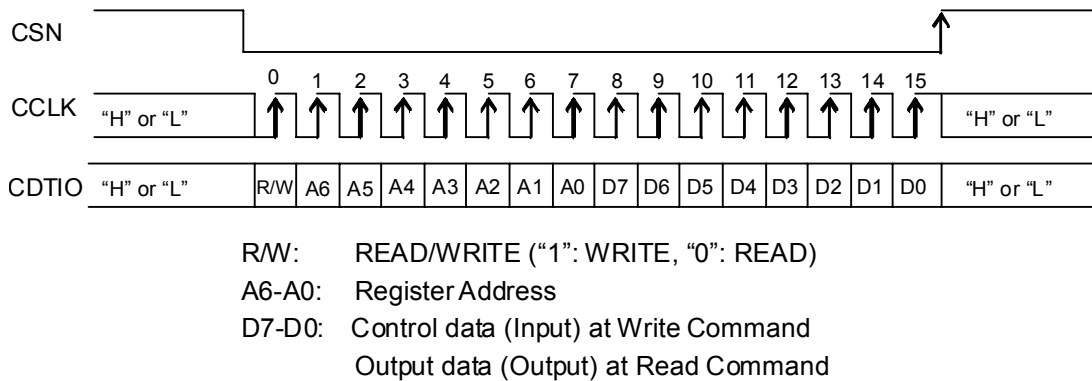

Figure 55. Serial Control Interface Timing 1

2. Continuous Data Writing Mode (00H~4FH)

Address is incremented automatically and data is written continuously. This mode does not support reading. When the written address reaches 4FH, it is automatically incremented to 00H. Writing to the address 0EH and 31H are ignored.

In this mode, registers are written by 3-wire serial interface pins (CSN, CCLK and CDTIO). The data on the 3-wire serial interface is 8 bit data, consisting of register address (MSB-first, 7bits) and control or output data (MSB-first, 8xN bits)). The receiving data is latched on a rising edge (“↑”) of CCLK. The first write data becomes effective between the rising edge (“↑”) and the falling edge (“↓”) of 16th CCLK. When the micro processor continues sending CDTI and CCLK clocks while the CSN pin = “L”, the address counter is incremented automatically and writing data becomes effective between the rising edge (“↑”) and the falling edge (“↓”) of every 8th CCLK. For the last address, writing data becomes effective between the rising edge (“↑”) of 8th CCLK and the rising edge (“↑”) of CSN. The clock speed of CCLK is 12.5MHz (max). The internal registers are initialized by the PDN pin = “L”.

Even through the writing data does not reach the last address; a write command can be completed when the CSN pin is set to “H”.

Note 51. When CSN “↑” was written before “↑” of 8th CCLK in continuous data writing mode, the previous data writing address becomes valid and the writing address is ignored.

Note 52. After 8bits data in the last address became valid, put the CSN pin “H” to complete the write command. If the CDTI and CCLK inputs are continued when the CSN pin = “L”, the data in the next address, which is incremented, is over written.

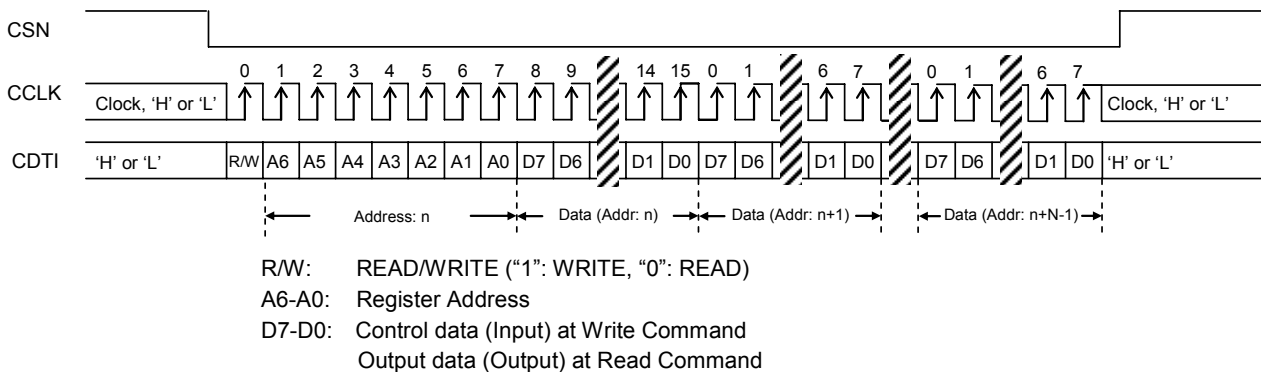

Figure 56. Serial Control Interface Timing 2 (Continuous Writing Mode)

(2) I2C-bus Control Mode (I2C pin = "H")

The AK4955 supports the fast-mode I²C-bus (max: 400kHz). Pull-up resistors at the SDA and SCL pins must be connected to 6V or less voltage.

(2)-1. WRITE Operations

Figure 57 shows the data transfer sequence for the I²C-bus mode. All commands are preceded by a START condition. A HIGH to LOW transition on the SDA line while SCL is HIGH indicates a START condition (Figure 70). After the START condition, a slave address is sent. This address is 7 bits long followed by the eighth bit that is a data direction bit (R/W). The most significant six bits of the slave address are fixed as "001001". The next bit is CAD0 (device address bit). This bit identifies the specific device on the bus. The hard-wired input pin (CAD0 pin) sets these device address bits (Figure 58). If the slave address matches that of the AK4955, the AK4955 generates an acknowledge and the operation is executed. The master must generate the acknowledge-related clock pulse and release the SDA line (HIGH) during the acknowledge clock pulse (Figure 71). A R/W bit value of "1" indicates that the read operation is to be executed, and "0" indicates that the write operation is to be executed.

The second byte consists of the control register address of the AK4955. The format is MSB first, and those most significant 1bit is fixed to zero (Figure 59). The data after the second byte contains control data. The format is MSB first, 8bits (Figure 60). The AK4955 generates an acknowledge after each byte is received. Data transfer is always terminated by a STOP condition generated by the master. A LOW to HIGH transition on the SDA line while SCL is HIGH defines a STOP condition (Figure 70).

The AK4955 can perform more than one byte write operation per sequence. After receipt of the third byte the AK4955 generates an acknowledge and awaits the next data. The master can transmit more than one byte instead of terminating the write cycle after the first data byte is transferred. After receiving each data packet the internal address counter is incremented by one, and the next data is automatically taken into the next address. If the address exceeds "4FH" prior to generating a stop condition, the address counter will "roll over" to 00H and the previous data will be overwritten.

The data on the SDA line must remain stable during the HIGH period of the clock. HIGH or LOW state of the data line can only be changed when the clock signal on the SCL line is LOW (Figure 72) except for the START and STOP conditions.

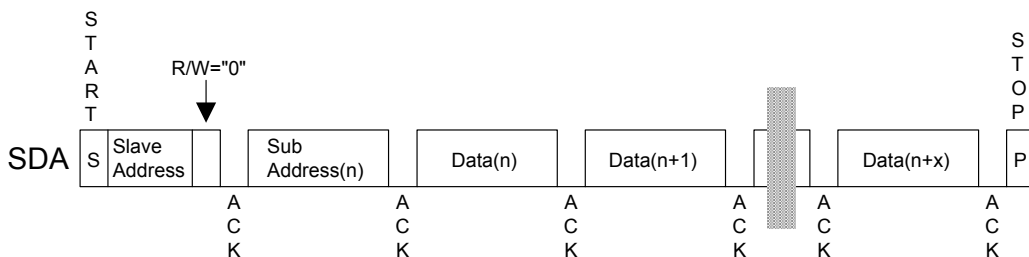

Figure 57. Data Transfer Sequence at I²C Bus Mode

0	0	1	0	0	1	CAD0	R/W
---	---	---	---	---	---	------	-----

Figure 58. The First Byte

0	A6	A5	A4	A3	A2	A1	A0
---	----	----	----	----	----	----	----

Figure 59. The Second Byte

D7	D6	D5	D4	D3	D2	D1	D0
----	----	----	----	----	----	----	----

Figure 60. The Third Byte

(2)-2. READ Operations

Set the R/W bit = "1" for the READ operation of the AK4955. After transmission of data, the master can read the next address's data by generating an acknowledge instead of terminating the write cycle after the receipt of the first data word. After receiving each data packet the internal address counter is incremented by one, and the next data is automatically taken into the next address. If the address exceeds 4FH prior to generating stop condition, the address counter will "roll over" to 00H and the data of 00H will be read out.

Note 50. Data reading is only available on the following addresses; 00 ~ 4FH and 50H ~ 6FH. When reading address 50H ~ 6FH, the register values are invalid.

The AK4955 supports two basic read operations: CURRENT ADDRESS READ and RANDOM ADDRESS READ.

(2)-2-1. CURRENT ADDRESS READ

The AK4955 has an internal address counter that maintains the address of the last accessed word incremented by one. Therefore, if the last access (either a read or write) were to address "n", the next CURRENT READ operation would access data from the address "n+1". After receipt of the slave address with R/W bit "1", the AK4955 generates an acknowledge, transmits 1-byte of data to the address set by the internal address counter and increments the internal address counter by 1. If the master does not generate an acknowledge but generates a stop condition instead, the AK4955 ceases the transmission.

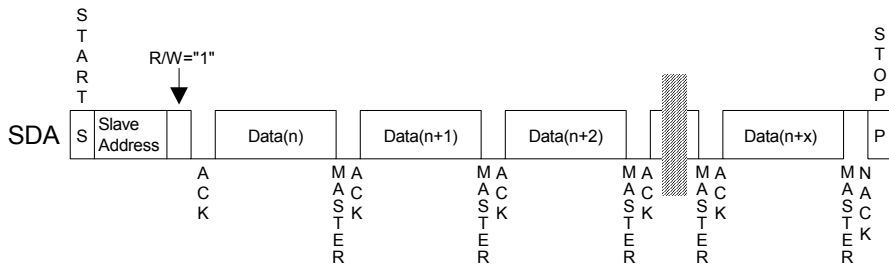

Figure 61. Current Address Read

(2)-2-2. RANDOM ADDRESS READ

The random read operation allows the master to access any memory location at random. Prior to issuing the slave address with the R/W bit "1", the master must first perform a "dummy" write operation. The master issues a start request, a slave address (R/W bit = "0") and then the register address to read. After the register address is acknowledged, the master immediately reissues the start request and the slave address with the R/W bit "1". The AK4955 then generates an acknowledge, 1 byte of data and increments the internal address counter by 1. If the master does not generate an acknowledge but generates a stop condition instead, the AK4955 ceases the transmission.

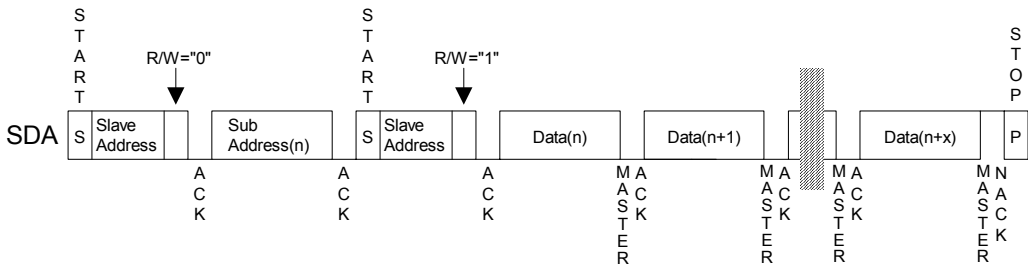

Figure 62. Random Address Read

■ Serial Control Interface to DSP

(1) DSP Access Format in 3-wire Mode

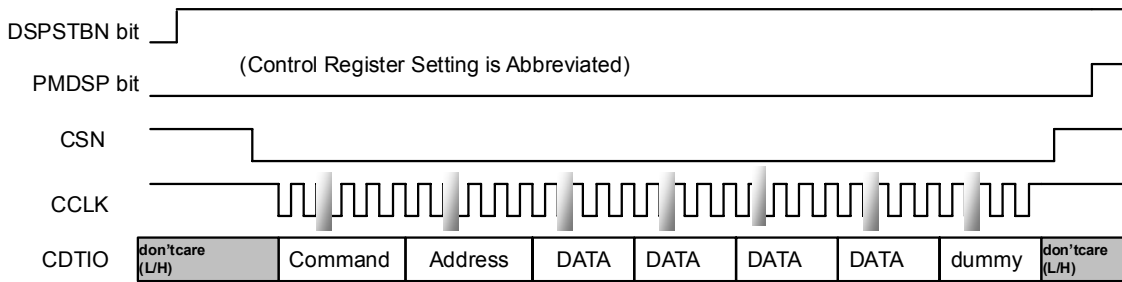

Figure 63. Consecutive Writing to RAM

Address length is 2byte fixed, and Data length is shown below.

Command	Address Length	Data Length	Description	Note
F1H	2byte	2byte	CRAM Write Data during RUN 2data	Address input is not necessary when writing to consecutive address during RUN. e.g. Input 2byte x 12 after 2byte address when writing to FBH. If the data is over write limit, it is ignored.
F2H	2byte	2byte	CRAM Write Data during RUN 3data	
F3H	2byte	2byte	CRAM Write Data during RUN 4data	
F4H	2byte	2byte	CRAM Write Data during RUN 5data	
F5H	2byte	2byte	CRAM Write Data during RUN 6data	
F6H	2byte	2byte	CRAM Write Data during RUN 7data	
F7H	2byte	2byte	CRAM Write Data during RUN 8data	
F8H	2byte	2byte	CRAM Write Data during RUN 9data	
F9H	2byte	2byte	CRAM Write Data during RUN 10data	
FAH	2byte	2byte	CRAM Write Data during RUN 11data	
FBH	2byte	2byte	CRAM Write Data during RUN 12data	
FCH	-	1byte	External Conditional Jump Code	
FDH	2byte	-	Write execution during RUN	Write data should be all "0".
FEH	2byte	2byte	CRAM Writing during RST	
FFH	2byte	5byte	PRAM Writing during RST	Address input is not necessary when writing to consecutive address. These writings are valid when DSPSTBN bit= "1" and PMDSP bit = "0".

If the written data exceeds the allotted amount, PRAM or CRAM data is over written.

* A 1byte dummy data write (all "1" or "0") is necessary after command, address length and data length writings as shown above when writing to DSP. This dummy data must be 2byte when writing to CRAM during a reset.

Table 64. List of Usable Write Commands in Write Sequence

1. RAM Writing Timing during RUN

Use this operation to rewrite CRAM during RUN. After inputting the assigned command code (8-bit) to select the number of data from 2 to 12, input the Starting Address of write (16-bit all 0) and the number of data assigned by command code in this order (write preparation). Upon completion of this operation, execute RAM write during RUN by inputting the corresponding command code and address (16-bit all 0) in this order (write execution).

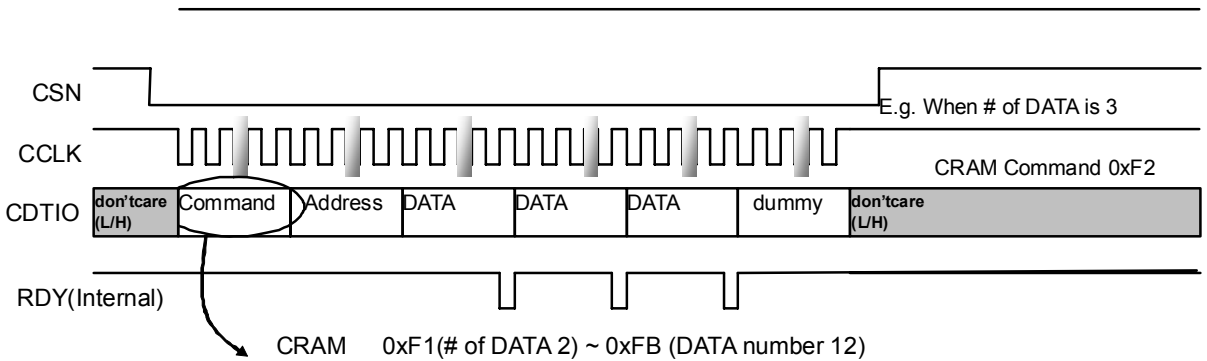

Figure 64. CRAM Write Preparation

2. RAM Reading Timing during RST (when DSPSTBN bit= “1” and PMDSP bit= “0”).

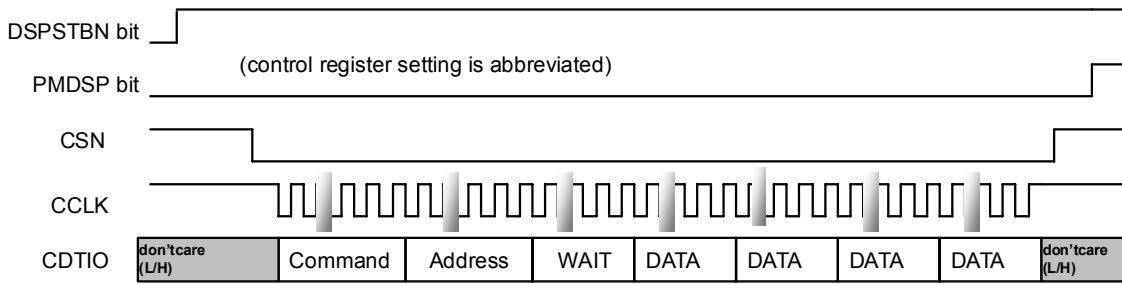

Figure 65. RAM Reading Timing during RST

RAM data can be readout during a reset.

There is a wait time (1byte) after command code and address inputs when reading RAM data. During this wait time, the CDTIO pin is in output state and the output data is indefinite. MSB data is output on the first falling edge of CCLK after the wait time.

Command code and Output data length are shown below.

Command	Description	Address Length	Data Length	Note
7EH	CRAM reading during RST.	2byte	2byte	Only the first read address is necessary when reading from consecutive address data.
7FH	PRAM reading during RST.	2byte	5byte	

Table 65. Command Code and Output Data in RAM Reading during a RST

3. MICR Reading Timing

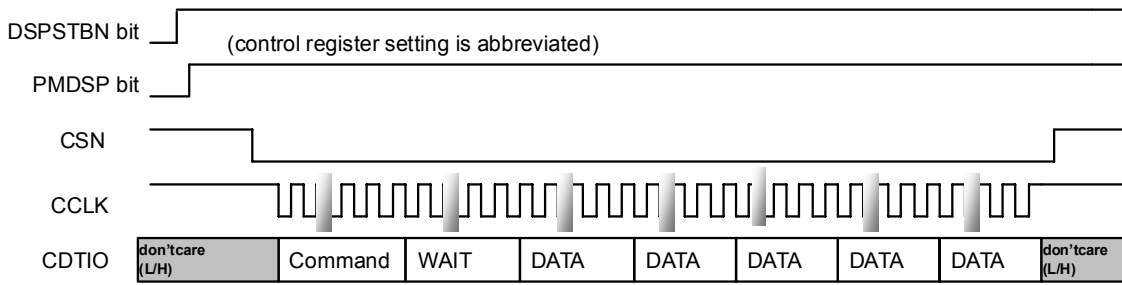

Figure 66. MICR Reading

There is a wait time (1byte) after command code and address inputs when reading MICR data. During this wait time, the CDTIO pin is in output state and the output data is indefinite. MSB data is output on the first falling edge of CCLK after the wait time.

Command	Data Length	Description
70H	4byte	MICR1 Reading
71H	4byte	MICR2 Reading
72H	4byte	MICR3 Reading
73H	4byte	MICR4 Reading

Table 66. Command Code and Data Length when Reading MRCI

4. Written Data Reading Timing during RUN

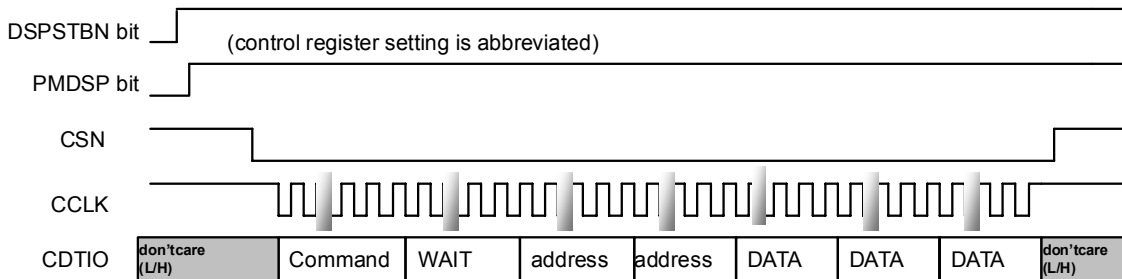

Figure 67. Written Data Reading during RUN

There is a wait time (1byte) after command code and address inputs when reading CRAM written data. During this wait time, the CDTIO pin is in output state and the output data is indefinite. MSB data is output on the first falling edge of CCLK after the wait time.

Command	Address Length	Data Length	Description	Note
FDH	2byte	2byte x n	CRAM written data reading during RUN	n=2~12

Table 67. Command Code and Data Length Reading during RUN

(2) DSP Access Format in I²C-bus Control Mode

1. WRITE Operation

In the AK4955, when a “Write-Slave-address assignment” is received at the first byte, the write command at the second byte and data at the third and succeeding bytes are received. At the data block, address and write data are received in a single-byte unit each in accordance with a command code. The number of write data bytes (*1 in Figure 68) is fixed by the received command code.

Data writings must be executed after an Acknowledge. There are some cases that 2LRCK wait time is needed depending on the written command. A 1byte dummy command (all “0” or “1”) must be written after inputting the data.

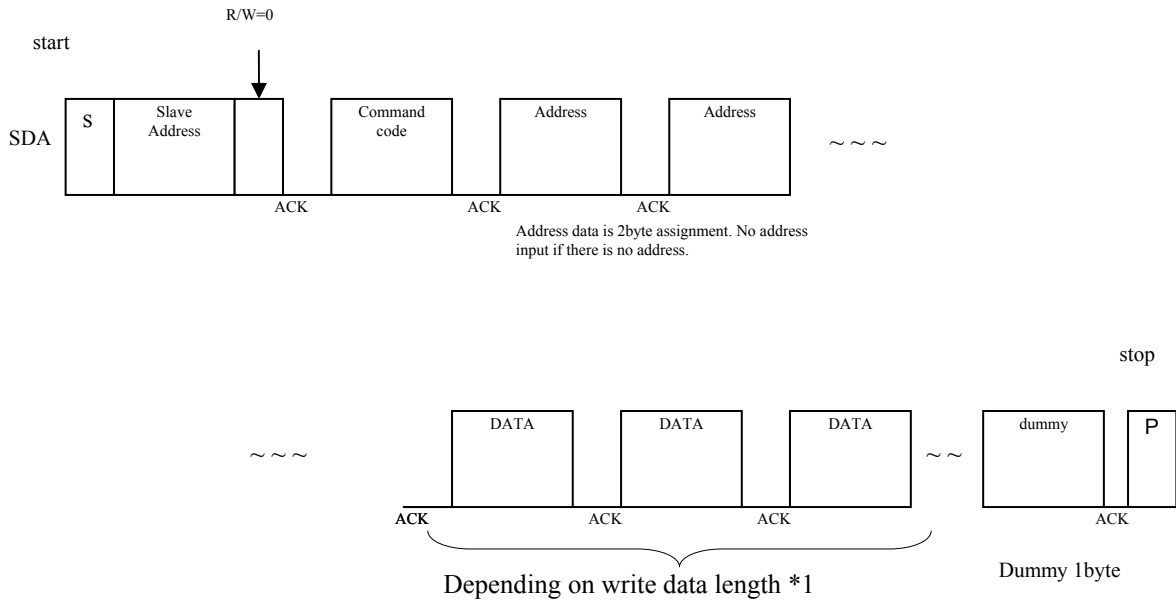

Figure 68. Write Sequence to DSP

Command	Address Length	Data Length	Content
F1H~FBH	2byte Assignment	2byte Assignment ×n (n=2~12)	CRAM write preparation during RUN. LSB 4bits of the command code assign the number of write operation. (F1H: 2, ... FBH: 12) Write operation exceeding the assigned number of write, abandons the data.
FCH	None	1byte Assignment	External Conditional Jump Code Input
FDH	2byte Assignment	None	CRAM writing during RUN. The address is all “0” input.
FEH	2byte Assignment	2byte Assignment ×n	CRAM writing during a system reset.
FFH	2byte Assignment	2byte Assignment ×n	PRAM writing during a system reset.

Note: Length of write data is variable with the areas to be written. When accessing RAM, it is possible to write data at sequential address locations by writing data continuously. Writing command codes other than above are prohibited.

Table 68. List of Usable Write Command Codes in Write Sequence

2. READ Operation

Random address read operation is only supported when accessing the internal DSP.

The random read operation allows the master to access any memory location at random. Prior to issuing the slave address with the R/W bit “1”, the master must first perform a “dummy” write operation. The master issues a start condition, a slave address (R/W bit = “0”) and then the register address to read. After the register address is acknowledged, the master immediately reissues the start condition and the slave address with the R/W bit “1”. The AK4955 then generates an acknowledge, 1 byte of data and increments the internal address counter by 1. If the master does not generate an acknowledge but generates a stop condition instead, the AK4955 ceases the transmission.

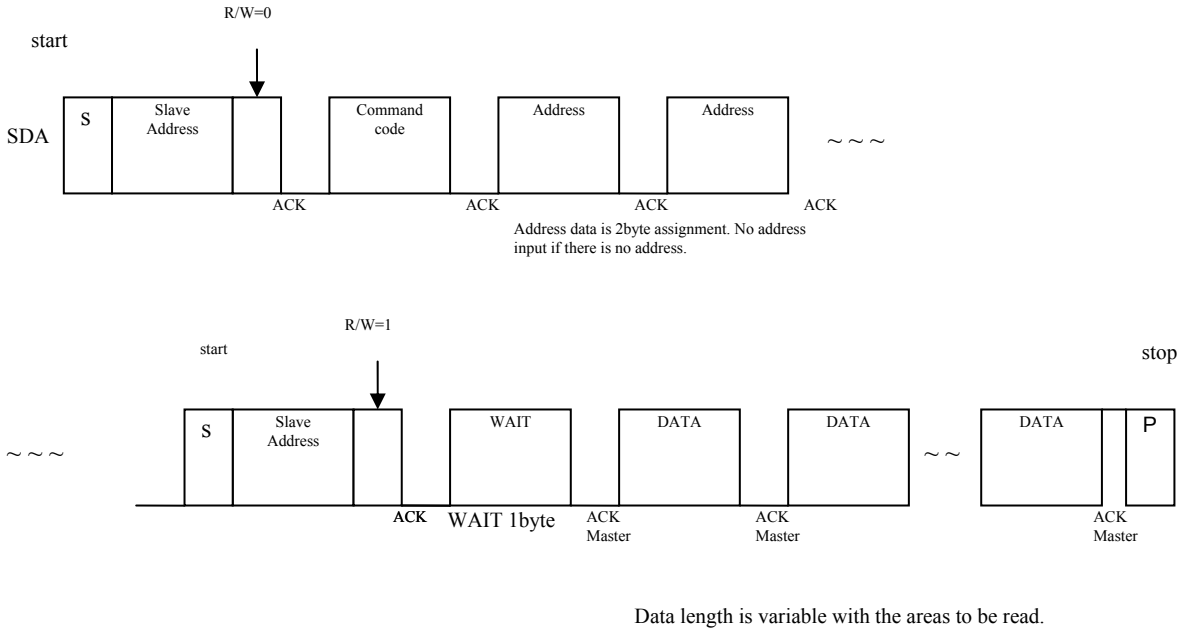

Figure 69. Random Address Read from DSP

Command	Address Length	Data Length	Content
70H	None	4byte	@MICR0 reading
71H	None	4byte	@MICR1 reading
72H	None	4byte	@MICR2 reading
73H	None	4byte	@MICR3 reading
7DH	2byte assignment	2byte assignment ×n (n=2~12)	CRAM write preparation data reading during RUN
7FH	2byte assignment	5byte×n	PRAM reading during a system reset
7EH	2byte assignment	2byte×n	CRAM reading during a system reset

Note 53. Length of read data is variable by command code. As for access to RAM, it is possible to read data at sequential address locations by reading data continuously. Reading command codes other than above are prohibited. There is a wait time (1byte) after an acknowledge following read commands after the dummy writing. During this wait time, the SDA pin is in output state and the output data is indefinite. MSB data is output after the first acknowledge following this wait time.

Table 69. List of Usable Read Command Codes in Read Sequence

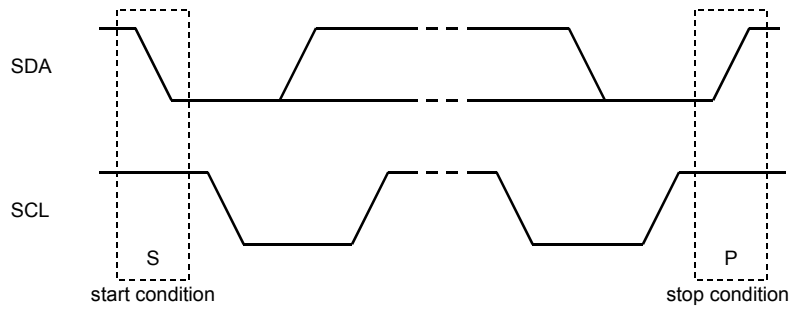

Figure 70. Start Condition and Stop Condition

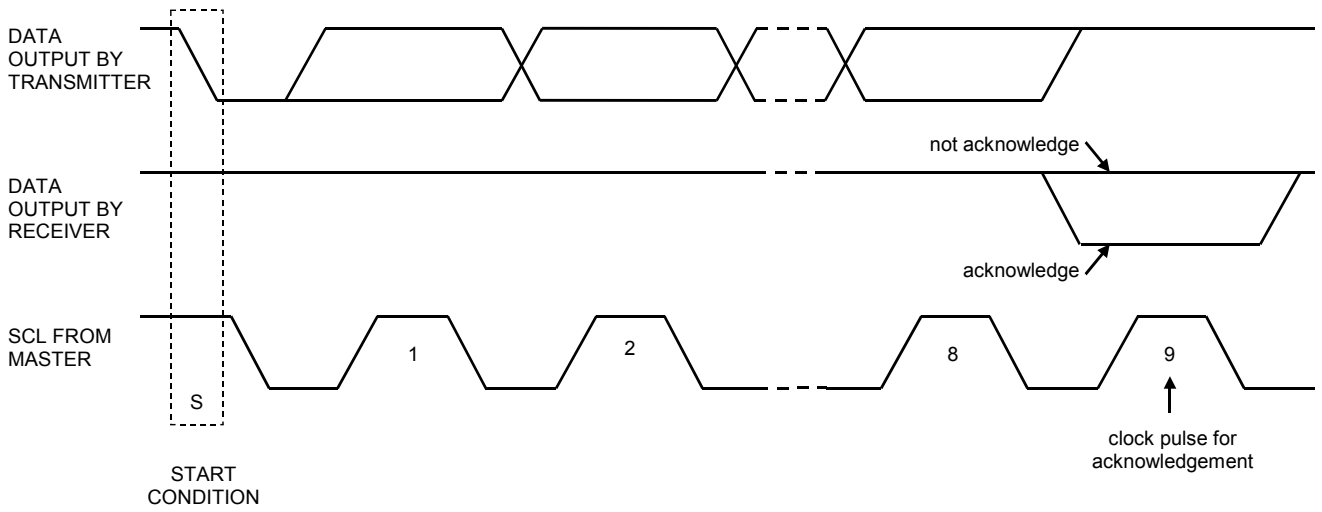

Figure 71. Acknowledge (I²C Bus)

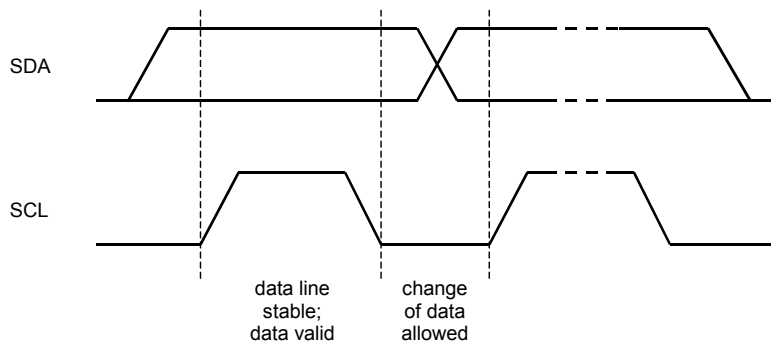

Figure 72. Bit Transfer (I²C Bus)

■ Checksum Function

The AK4955 has a checksum function. When SUMRSTN bit = “1”, checksum of writing data is updated. When SUMRSTN bit = “0”, the checksum value is rest to zero. Checksum is calculated in 8-bit step. When the checksum value exceeds 255 in decimal format, the values will be subtracted by 256. Checksum value can be monitored by reading CSUM7-0 bits. This function is only valid in 3-wire control mode (I2C pin = “L”).

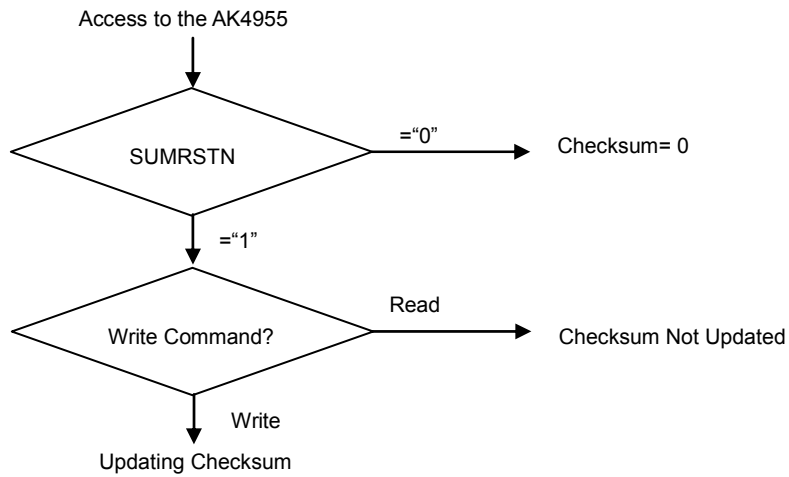

Figure 73. Flowchart of Checksum

■ DSP Power-up Sequence

Set DSPSTBN bit to “1” to supply clock to the DSP after clock is stabilized (PLL lock). Program downloadings to the DSP become available by setting DSPSTBN bit “0” → “1”. (There is no time limit for DSP program download.) Write a program to PRAM and data to CRAM. The DSP is powered-up and DRAM initialization is started by PMDSP bit “0” → “1”, after downloading a program.

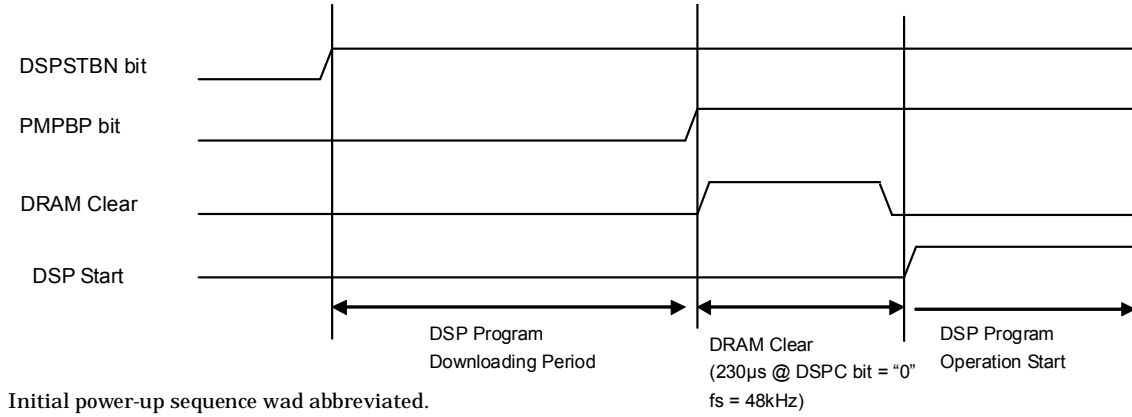

Figure 74. DSP Power-up Sequence

In the DRAM clear sequence, it is possible to send commands to the DSP. (DSP is stopped during DRAM clear sequence. The sent CRAM write command is accepted automatically after this sequence is completed.)

Initialization period of the DRAM is dependent on DSPC bit setting and sampling frequency.

Maximum 6LRCK≈125µsec@48kHz when DSPC bit= “1” (when DSP=512fs).

Maximum 11LRCK≈230µsec@48kHz when DSPC bit= “0” (when DSP=256fs).

■ Register Map

Addr	Register Name	D7	D6	D5	D4	D3	D2	D1	D0
00H	Power Management 1	PMPFIL	PMVCM	PMDSP	PMSPK	PMLO	PMDAC	PMADR	PMADL
01H	Power Management 2	SPPSN	DSPSTBN	PMBPG	PMBP	M/S	SUMRSTN	MCKO	PMPLL
02H	Signal Select 1	PMMICR	PMMICL	PMMMP	MICL	MGAIN3	MGAIN2	MGAIN1	MGAIN0
03H	Signal Select 2	SPKG1	SPKG0	BEEPS	DACS	0	0	INR	INL
04H	Signal Select 3	MONO1	MONO2	LOPS	DACL	BEEPL	0	LVCM1	LVCM0
05H	Mode Control 1	PLL3	PLL2	PLL1	PLL0	BCKO	0	DIF1	DIF0
06H	Mode Control 2	PS1	PS0	FFTE	DSPC	FS3	FS2	FS1	FS0
07H	Mode Control 3	READ	THDET	SMUTE	DVOLC	OVOLC	IVOLC	DEM1	DEM0
08H	Digital MIC	0	0	PMDMR	PMDML	DCLKE	0	DCLKP	DMIC
09H	Timer Select	ADRST1	ADRST0	0	0	0	0	0	DVTM
0AH	ALC Timer Select	FRN	ZTM1	ZTM0	WTM2	WTM1	WTM0	RFST1	RFST0
0BH	ALC Mode Control 1	LFST	ALC2	ALC1	ZELMN	LMAT1	LMAT0	LMTH1	LMTH0
0CH	ALC Mode Control 2	IREF7	IREF6	IREF5	IREF4	IREF3	IREF2	IREF1	IREF0
0DH	ALC Mode Control 3	RGAIN1	RGAIN0	OREF5	OREF4	OREF3	OREF2	OREF1	OREF0
0EH	ALC Volume	VOL7	VOL6	VOL5	VOL4	VOL3	VOL2	VOL1	VOL0
0FH	Lch Input Volume Control	IVL7	IVL6	IVL5	IVL4	IVL3	IVL2	IVL1	IVL0
10H	Rch Input Volume Control	IVR7	IVR6	IVR5	IVR4	IVR3	IVR2	IVR1	IVR0
11H	Lch Output Volume Control	OVL7	OVL6	OVL5	OVL4	OVL3	OVL2	OVL1	OVL0
12H	Rch Output Volume Control	OVR7	OVR6	OVR5	OVR4	OVR3	OVR2	OVR1	OVR0
13H	Lch Digital Volume Control	DVL7	DVL6	DVL5	DVL4	DVL3	DVL2	DVL1	DVL0
14H	Rch Digital Volume Control	DVR7	DVR6	DVR5	DVR4	DVR3	DVR2	DVR1	DVR0
15H	BEEP Control	BPCONT	BPVCM	BPM1	BPM0	0	0	BPFR1	BPFR0
16H	BEEP ON Time	BPON7	BPON6	BPON5	BPON4	BPON3	BPON2	BPON1	BPON0
17H	BEEP OFF Time	BPOFF7	BPOFF6	BPOFF5	BPOFF4	BPOFF3	BPOFF2	BPOFF1	BPOFF0
18H	BEEP Repeat Count	0	BPTM6	BPTM5	BPTM4	BPTM3	BPTM2	BPTM1	BPTM0
19H	BEEP Volume Control	BPOUT	0	0	0	BPLVL3	BPLVL2	BPLVL1	BPLVL0
1AH	Video Control	0	0	0	0	VG1	VG0	PMCP	PMV
1BH	HPF Filter Control	0	0	0	0	0	HPFC1	HPFC0	HPFAD
1CH	Digital Filter Select 1	0	0	LPF	HPF	EQ0	GN1	GN0	FIL3
1DH	Digital Filter Control	0	0	0	0	DSPBF	PDFAC	ADCPF	PFSDO
1EH	HPF3 Co-efficient 0	F1A7	F1A6	F1A5	F1A4	F1A3	F1A2	F1A1	F1A0
1FH	HPF3 Co-efficient 1	0	0	F1A13	F1A12	F1A11	F1A10	F1A9	F1A8
20H	HPF3 Co-efficient 2	F1B7	F1B6	F1B5	F1B4	F1B3	F1B2	F1B1	F1B0
21H	HPF3 Co-efficient 3	0	0	F1B13	F1B12	F1B11	F1B10	F1B9	F1B8
22H	LPF Co-efficient 0	F2A7	F2A6	F2A5	F2A4	F2A3	F2A2	F2A1	F2A0
23H	LPF Co-efficient 1	0	0	F2A13	F2A12	F2A11	F2A10	F2A9	F2A8
24H	LPF Co-efficient 2	F2B7	F2B6	F2B5	F2B4	F2B3	F2B2	F2B1	F2B0
25H	LPF Co-efficient 3	0	0	F2B13	F2B12	F2B11	F2B10	F2B9	F2B8
26H	FIL3 Co-efficient 0	F3A7	F3A6	F3A5	F3A4	F3A3	F3A2	F3A1	F3A0
27H	FIL3 Co-efficient 1	F3AS	0	F3A13	F3A12	F3A11	F3A10	F3A9	F3A8
28H	FIL3 Co-efficient 2	F3B7	F3B6	F3B5	F3B4	F3B3	F3B2	F3B1	F3B0
29H	FIL3 Co-efficient 3	0	0	F3B13	F3B12	F3B11	F3B10	F3B9	F3B8
2AH	EQ0-efficient 0	E0A7	E0A6	E0A5	E0A4	E0A3	E0A2	E0A1	E0A0
2BH	EQ0-efficient 1	E0A15	E0A14	E0A13	E0A12	E0A11	E0A10	E0A9	E0A8
2CH	EQ0-efficient 2	E0B7	E0B6	E0B5	E0B4	E0B3	E0B2	E0B1	E0B0
2DH	EQ0-efficient 3	0	0	E0B13	E0B12	E0B11	E0B10	E0B9	E0B8
2EH	EQ0-efficient 4	E0C7	E0C6	E0C5	E0C4	E0C3	E0C2	E0C1	E0C0
2FH	EQ0-efficient 5	E0C15	E0C14	E0C13	E0C12	E0C11	E0C10	E0C9	E0C8

Addr	Register Name	D7	D6	D5	D4	D3	D2	D1	D0
30H	Digital Filter Select 2	0	0	0	EQ5	EQ4	EQ3	EQ2	EQ1
31H	Check Sum	SUM7	SUM6	SUM5	SUM4	SUM3	SUM2	SUM1	SUM0
32H	E1 Co-efficient 0	E1A7	E1A6	E1A5	E1A4	E1A3	E1A2	E1A1	E1A0
33H	E1 Co-efficient 1	E1A15	E1A14	E1A13	E1A12	E1A11	E1A10	E1A9	E1A8
34H	E1 Co-efficient 2	E1B7	E1B6	E1B5	E1B4	E1B3	E1B2	E1B1	E1B0
35H	E1 Co-efficient 3	E1B15	E1B14	E1B13	E1B12	E1B11	E1B10	E1B9	E1B8
36H	E1 Co-efficient 4	E1C7	E1C6	E1C5	E1C4	E1C3	E1C2	E1C1	E1C0
37H	E1 Co-efficient 5	E1C15	E1C14	E1C13	E1C12	E1C11	E1C10	E1C9	E1C8
38H	E2 Co-efficient 0	E2A7	E2A6	E2A5	E2A4	E2A3	E2A2	E2A1	E2A0
39H	E2 Co-efficient 1	E2A15	E2A14	E2A13	E2A12	E2A11	E2A10	E2A9	E2A8
3AH	E2 Co-efficient 2	E2B7	E2B6	E2B5	E2B4	E2B3	E2B2	E2B1	E2B0
3BH	E2 Co-efficient 3	E2B15	E2B14	E2B13	E2B12	E2B11	E2B10	E2B9	E2B8
3CH	E2 Co-efficient 4	E2C7	E2C6	E2C5	E2C4	E2C3	E2C2	E2C1	E2C0
3DH	E2 Co-efficient 5	E2C15	E2C14	E2C13	E2C12	E2C11	E2C10	E2C9	E2C8
3EH	E3 Co-efficient 0	E3A7	E3A6	E3A5	E3A4	E3A3	E3A2	E3A1	E3A0
3FH	E3 Co-efficient 1	E3A15	E3A14	E3A13	E3A12	E3A11	E3A10	E3A9	E3A8
40H	E3 Co-efficient 2	E3B7	E3B6	E3B5	E3B4	E3B3	E3B2	E3B1	E3B0
41H	E3 Co-efficient 3	E3B15	E3B14	E3B13	E3B12	E3B11	E3B10	E3B9	E3B8
42H	E3 Co-efficient 4	E3C7	E3C6	E3C5	E3C4	E3C3	E3C2	E3C1	E3C0
43H	E3 Co-efficient 5	E3C15	E3C14	E3C13	E3C12	E3C11	E3C10	E3C9	E3C8
44H	E4 Co-efficient 0	E4A7	E4A6	E4A5	E4A4	E4A3	E4A2	E4A1	E4A0
45H	E4 Co-efficient 1	E4A15	E4A14	E4A13	E4A12	E4A11	E4A10	E4A9	E4A8
46H	E4 Co-efficient 2	E4B7	E4B6	E4B5	E4B4	E4B3	E4B2	E4B1	E4B0
47H	E4 Co-efficient 3	E4B15	E4B14	E4B13	E4B12	E4B11	E4B10	E4B9	E4B8
48H	E4 Co-efficient 4	E4C7	E4C6	E4C5	E4C4	E4C3	E4C2	E4C1	E4C0
49H	E4 Co-efficient 5	E4C15	E4C14	E4C13	E4C12	E4C11	E4C10	E4C9	E4C8
4AH	E5 Co-efficient 0	E5A7	E5A6	E5A5	E5A4	E5A3	E5A2	E5A1	E5A0
4BH	E5 Co-efficient 1	E5A15	E5A14	E5A13	E5A12	E5A11	E5A10	E5A9	E5A8
4CH	E5 Co-efficient 2	E5B7	E5B6	E5B5	E5B4	E5B3	E5B2	E5B1	E5B0
4DH	E5 Co-efficient 3	E5B15	E5B14	E5B13	E5B12	E5B11	E5B10	E5B9	E5B8
4EH	E5 Co-efficient 4	E5C7	E5C6	E5C5	E5C4	E5C3	E5C2	E5C1	E5C0
4FH	E5 Co-efficient 5	E5C15	E5C14	E5C13	E5C12	E5C11	E5C10	E5C9	E5C8

Note 54. PDN pin = "L" resets the registers to their default values.

Note 55. The bits defined as 0 must contain a "0" value.

Note 56. Address 0EH and 31H are read only registers. Writing access to these addresses is ignored and does not effect the operation.

■ Register Definitions

Addr	Register Name	D7	D6	D5	D4	D3	D2	D1	D0
00H	Power Management 1	PMPFIL	PMVCM	PMDSP	PMSPK	PMLO	PMDAC	PMADR	PMADL
	R/W	R/W	R/W	R/W	R/W	R/W	R/W	R/W	R/W
	Default	0	0	0	0	0	0	0	0

PMADL: ADC Lch Power Management

0: Power-down (default)

1: Power-up

PMADR: ADC Rch Power Management

0: Power down (default)

1: Power up

When the PMADL or PMADR bit is changed from “0” to “1”, the initialization cycle ($1059/f_s=21.3\text{ms}$ @48kHz, ADRST1-0 bits = “00”) starts. After initializing, digital data of the ADC is output.

PMDAC: DAC Power Management

0: Power-down (default)

1: Power-up

PMLO: Stereo Line Output Power Management

0: Power-down (default)

1: Power-up

PMSPK: Speaker-Amp Power Management

0: Power-down (default)

1: Power-up

PMDSP: DSP Power Management

0: Power-down (default)

1: Power-up

PMVCM: VCOM and Regulator (2.3V) Power Management

0: Power down (default)

1: Power up

PMPFIL: Programmable Filter Block (LPF/FIL3/EQ/5 Band EQ/ALC) Power Management

0: Power down (default)

1: Power up

The AK4955 can be powered-down by writing “0” to the address “00H” and PMPLL, PMM1CL/R, PMMP, PMBPG, PMDML/R, DMPE, PMV, PMCP and MCKO bits. In this case, register values are maintained.

Addr	Register Name	D7	D6	D5	D4	D3	D2	D1	D0
01H	Power Management 2	SPPSN	DSPSTBN	PMBPG	PMBP	M/S	SUMRSTN	MCKO	PMPLL
	R/W	R/W	R/W	R/W	R/W	R/W	R/W	R/W	R/W
	Default	0	0	0	0	0	0	0	0

PMPLL: PLL Power Management

- 0: EXT Mode and Power down (default)
- 1: PLL Mode and Power up

MCKO: Master Clock Output Enable

- 0: Disable: MCKO pin = "L" (default)
- 1: Enable: Output frequency is selected by PS1-0 bits.

SUMRSTN: Reset bit for Checksum

- 0: Reset the checksum value to all "0". (default)
- 1: Checksum reset release.

M/S: Master / Slave Mode Select

- 0: Slave Mode (default)
- 1: Master Mode

PMBP: Mono Input Power Management

- 0: Power down (default)
- 1: Power up

Stereo lineout and speaker path settings from the MIN pin can be set by BEEPL bit and BEEPS bit, respectively.

PMBPG: BEEP Generator Power Management

- 0: Power down (default)
- 1: Power up

DSPSTBN: DSP Clock Control

- 0: Clock Stop (default)
 - 1: Clock Supply
- Program downloading is available when DSPSTBN bit = "1"

SPPSN: Speaker-Amp Power-Save Mode

- 0: Power Save Mode (default)
- 1: Normal Operation

When SPPSN bit is "0", Speaker-Amp is in power-save mode. In this mode, the SPP pin goes to Hi-Z and the SPN pin outputs SVDD/2 voltage. When PMSPK bit = "1", SPPSN bit is enabled. After the PDN pin is set to "L", Speaker-Amp is in power-down mode since PMSPK bit is "0".

Addr	Register Name	D7	D6	D5	D4	D3	D2	D1	D0
02H	MIC gain Control 1	PMMICR	PMMICL	PMMP	MICL	MGAIN3	MGAIN2	MGAIN1	MGAIN0
	R/W	R/W	R/W	R/W	R/W	R/W	R/W	R/W	R/W
	Default	0	0	0	0	0	1	1	0

MGAIN3-0: MIC-Amp Gain Control ([Table 21](#))

MICL: MIC Power Output Voltage Select

0: typ 2.5 V (AVDD= 2.9~3.6V) (default)

1: typ 2.0V (AVDD= 2.7~3.6V)

PMMP: MIC Power Management

0: Power down (default)

1: Power up

PMMICL: MIC-amp Lch Power Management

0: Power down (default)

1: Power up

PMMICR: MIC-amp Rch Power Management

0: Power down (default)

1: Power up

Addr	Register Name	D7	D6	D5	D4	D3	D2	D1	D0
03H	Signal Select 2	SPKG1	SPKG0	BEEPS	DACS	0	0	INR	INL
	R/W	R/W	R/W	R/W	R/W	R	R	R/W	R/W
	Default	0	0	0	0	0	0	0	0

INL: ADC Lch Input Source Select

0: LIN1 pin (default)

1: LIN2 pin

INR: ADC Rch Input Source Select

0: RIN1 pin (default)

1: RIN2 pin

DACS: Signal Switch Control from DAC to Speaker-Amp

0: OFF (default)

1: ON

When DACS bit is "1", DAC output signal is input to Speaker-Amp.

BEEPS: Signal Switch Control from the MIN pin to Speaker-Amp

0: OFF (default)

1: ON

SPKG1-0: Speaker-Amp Output Gain Select ([Table 60](#))

Addr	Register Name	D7	D6	D5	D4	D3	D2	D1	D0
04H	Signal Select 3	MONO1	MONO0	LOPS	DACL	BEEPL	0	LVCM1	LVCM0
	R/W	R/W	R/W	R/W	R/W	R/W	R	R/W	R/W
	Default	0	0	0	0	0	0	0	1

LVCM1-0: Stereo Line Output Gain and Common Voltage Setting ([Table 58](#))

BEEPL: Signal Switch Control from the MIN pin to Lineout

0: OFF (default)

1: ON

DACL: DAC Output Signal to Stereo Line Amp Control

0: OFF (default)

1: ON

When PMLO bit = "1", this bit setting is enabled. LOUT and ROUT pins output VSS1 when PMLO bit = "0".

LOPS: Stereo Line Output Power Save

0: Normal Operation (default)

1: Power Save Mode

MONO1-0: LOUT/ROUT Output Signal Mode Select ([Table 59](#))

Addr	Register Name	D7	D6	D5	D4	D3	D2	D1	D0
05H	Mode Control 1	PLL3	PLL2	PLL1	PLL0	BCKO	0	DIF1	DIF0
	R/W	R/W	R/W	R/W	R/W	R/W	R	R/W	R/W
	Default	1	1	0	0	0	0	1	0

DIF1-0: Audio Interface Format ([Table 17](#))

Default: "10" (MSB justified)

BCKO: Master Mode BICK Output Frequency Setting ([Table 15](#))

PLL3-0: PLL Reference Clock Select ([Table 4](#))

Default: "1100"

Addr	Register Name	D7	D6	D5	D4	D3	D2	D1	D0
06H	Mode Control 2	PS1	PS0	FFTE	DSPC	FS3	FS2	FS1	FS0
	R/W	R/W	R/W	R/W	R/W	R/W	R/W	R/W	R/W
	Default	0	0	0	0	0	0	0	0

FS3-0: Sampling Frequency ([Table 5](#), [Table 6](#)) and MCKI Frequency Setting ([Table 11](#))

These bits control sampling frequency in PLL mode, and MCKI frequency in EXT mode.

DSPC: DSP Clock Select

0: 256fs (default)

1: 512fs

FFTE: FFT, iFFT Circuit Power Management

0: Power down (default)

1: Power up

PS1-0: MCKO Frequency Setting ([Table 9](#))

Default: "00" (256fs)

Addr	Register Name	D7	D6	D5	D4	D3	D2	D1	D0
07H	Mode Control 3	READ	THDET	SMUTE	DVOLC	OVOLC	IVOLC	DEM1	DEM0
	R/W	R/W	R	R/W	R/W	R/W	R/W	R/W	R/W
	Default	0	0	0	1	1	1	0	1

DEM1-0: De-emphasis Control ([Table 39](#))

Default: "01" (OFF)

IVOLC: IVOL Control

0: Independent

1: Dependent (default)

When IVOLC bit = "1", IVL7-0 bits control both Lch and Rch volume levels, while register values of IVL7-0 bits are not written to IVR7-0 bits.

OVOLC: Output Digital Volume Control Mode Select

0: Independent

1: Dependent (default)

When OVOLC bit = "1", OVL7-0 bits control both Lch and Rch volume levels, while register values of OVL7-0 bits are not written to OVR7-0 bits.

DVOLC: Output Digital Volume2 Control Mode Select

0: Independent

1: Dependent (default)

When DVOLC bit = "1", DVL7-0 bits control both Lch and Rch volume levels, while register values of DVL7-0 bits are not written to DVR7-0 bits.

SMUTE: Soft Mute Control

0: Normal Operation (default)

1: DAC outputs soft-muted

THDET: Thermal Shutdown Detection

0: Thermal Shutdown Off (default)

1: Thermal Shutdown ON

READ: Read Function Enable

0: Disable (default)

1: Enable

Addr	Register Name	D7	D6	D5	D4	D3	D2	D1	D0
08H	Digital MIC	0	0	PMDMR	PMDML	DCLKE	0	DCLKP	DMIC
	R/W	R	R	R/W	R/W	R/W	R	R/W	R/W
	Default	0	0	0	0	0	0	0	0

DMIC: Digital Microphone Connection Select

0: Analog Microphone (default)

1: Digital Microphone

DCLKP: Data Latching Edge Select

0: Lch data is latched on the DMCLK rising edge (“↑”). (default)

1: Lch data is latched on the DMCLK falling edge (“↓”).

DCLKE: DMCLK pin Output Clock Control

0: “L” Output (default)

1: 64fs Output

PMDML/R: Input Signal Select with Digital Microphone (Table 20)

Default: “00”

ADC digital block is powered-down by PMDML = PMDMR bits = “0” when selecting a digital microphone input (DMIC bit = “1”).

Addr	Register Name	D7	D6	D5	D4	D3	D2	D1	D0
09H	Timer Select	ADRST1	ADRST0	0	0	0	0	0	DVTM
	R/W	R/W	R/W	R	R	R	R	R	R/W
	Default	0	0	0	0	0	0	0	0

DVTM: Digital Volume Soft Transition Time Setting (Table 42)

Default: “0” (1024/fs)

This transition time is for when DVL7-0 bits or DVR7-0bits are changed from 00H to FFH.

ADRST1-0: ADC Initial Cycle Setting (Table 16)

Default: “00” (1059/fs)

Addr	Register Name	D7	D6	D5	D4	D3	D2	D1	D0
0AH	ALC Timer Select	FRN	ZTM1	ZTM0	WTM2	WTM1	WTM0	RFST1	RFST0
	R/W	R/W	R/W	R/W	R/W	R/W	R/W	R/W	R/W
	Default	0	0	0	0	0	0	0	1

RFST1-0: ALC First Recovery Speed ([Table 34](#))
Default: "01" (Quad Speed)

WTM2-0: ALC Recovery Waiting Period ([Table 30](#))
Default: "000" (128/fs).
A period of recovery operation when any limiter operation does not occur during ALC operation

ZTM1-0: ALC Zero Cross Timeout Setting ([Table 29](#))
Default: "000" (128/fs).
In case of the μ P WRITE operation or ALC recovery operation, the volume is changed at zero crossing or timeout.

FRN: ALC First Recovery Function Enable
0: Enable (default)
1: Disable

Addr	Register Name	D7	D6	D5	D4	D3	D2	D1	D0
0BH	ALC Mode Control 1	LFST	ALC2	ALC1	ZELMN	LMAT1	LMAT0	LMTH1	LMTH0
	R/W	R/W	R/W	R/W	R/W	R/W	R/W	R/W	R/W
	Default	0	0	0	0	0	0	0	0

LMTH1-0: ALC Limiter Detection Level / Recovery Counter Reset Level ([Table 27](#))
Default: "00"

LMAT1-0: ALC Limiter ATT Step ([Table 28](#))
Default: "00"

ZELMN: Zero Crossing Detection Enable at ALC Limiter Operation
0: Enable (default)
1: Disable

ALC1: ALC Enable for Recording
0: Recording ALC Disable (default)
1: Recording ALC Enable

ALC2: ALC Enable for Playback
0: Playback ALC Disable (default)
1: Playback ALC Enable

LFST: ALC Limiter operation when the output level exceed FS(Full-scale) level.
0: The volume is changed at zero crossing or zero crossing time out. (default)
1: When output of ALC is larger than FS, OVOL value is changed immediately (1/fs).

Addr	Register Name	D7	D6	D5	D4	D3	D2	D1	D0
0CH	ALC Mode Control 2	IREF7	IREF6	IREF5	IREF4	IREF3	IREF2	IREF1	IREF0
	R/W	R/W	R/W	R/W	R/W	R/W	R/W	R/W	R/W
	Default	1	1	1	0	0	0	0	1

IREF7-0: Reference Value of ALC Recovery Operation (Recording). 0.375dB step, 242 Level ([Table 32](#))
Default: "E1H" (+30.0dB)

Addr	Register Name	D7	D6	D5	D4	D3	D2	D1	D0
0DH	ALC Mode Control 3	RGAIN1	RGAIN0	OREF5	OREF4	OREF3	OREF2	OREF1	OREF0
	R/W	R/W	R/W	R/W	R/W	R/W	R/W	R/W	R/W
	Default	0	0	1	0	1	0	0	0

OREF7-0: Reference Value of ALC Recovery Operation (Playback). 0.375dB step, 50 Level ([Table 33](#))
Default: "28H" (+6.0dB)

RGAIN1-0: ALC Recovery GAIN Step ([Table 31](#))
Default: "00"

Addr	Register Name	D7	D6	D5	D4	D3	D2	D1	D0
0EH	ALC Volume	VOL7	VOL6	VOL5	VOL4	VOL3	VOL2	VOL1	VOL0
	R/W	R	R	R	R	R	R	R	R
	Default	1	0	0	1	0	0	0	1

VOL7-0: Current ALC volume value, 0.375dB step, 242 Level, Read operation only ([Table 35](#))

Addr	Register Name	D7	D6	D5	D4	D3	D2	D1	D0
0FH	Lch Input Volume Control	IVL7	IVL6	IVL5	IVL4	IVL3	IVL2	IVL1	IVL0
10H	Rch Input Volume Control	IVR7	IVR6	IVR5	IVR4	IVR3	IVR2	IVR1	IVR0
	R/W	R/W	R/W	R/W	R/W	R/W	R/W	R/W	R/W
	Default	1	1	1	0	0	0	0	1

IVL7-0, IVR7-0: Input Digital Volume, 0.375dB step, 242 Level ([Table 38](#))
Default: "E1H" (+30dB)

Addr	Register Name	D7	D6	D5	D4	D3	D2	D1	D0
11H	Lch Output Volume Control	OVL7	OVL6	OVL5	OVL4	OVL3	OVL2	OVL1	OVL0
12H	Rch Output Volume Control	OVR7	OVR6	OVR5	OVR4	OVR3	OVR2	OVR1	OVR0
	R/W	R/W	R/W	R/W	R/W	R/W	R/W	R/W	R/W
	Default	1	0	0	1	0	0	0	1

OVL7-0, OVR7-0: Output Digital Volume ([Table 40](#))
Default: "91H" (0dB)

Addr	Register Name	D7	D6	D5	D4	D3	D2	D1	D0
13H	Lch Digital Volume Control	DVOL7	DVOL6	DVOL5	DVOL4	DVOL3	DVOL2	DVOL1	DVOL0
14H	Rch Digital Volume Control	DVOR7	DVOR6	DVOR5	DVOR4	DVOR3	DVOR2	DVOR1	DVOR0
	R/W	R/W	R/W	R/W	R/W	R/W	R/W	R/W	R/W
	Default	0	0	0	1	1	0	0	0

DVOL7-0, DVOR7-0: Output Digital Volume 2 (Table 41)

Default: "18H" (0dB)

Addr	Register Name	D7	D6	D5	D4	D3	D2	D1	D0
15H	BEEP Control	BPCNT	BPVCM	BPM1	BPM0	0	0	BPFR1	BPFR0
	R/W	R/W	R/W	R/W	R/W	R	R	R/W	R/W
	Default	0	0	0	0	0	0	0	0

BPFR1-0: BEEP Output Frequency Setting (Table 48, Table 49)

Default: "00H"

BPM1-0 bits: BEEP Mode Select (Table 43)

Default: "00" Internal Resistance Mode

BPVCM: Common Voltage Select of MIN input Amp

0: typ. 1.15V (default)

1: typ. 1.65V

BPCNT: BEEP Output Mode Select

0: Discontinuous Output Mode: Beep is output for the number of times that is set by BPTM6-0 bits. (default)

1: Continuous Output Mode: Beep is output while BPCNT bit = "1".

Addr	Register Name	D7	D6	D5	D4	D3	D2	D1	D0
16H	BEEP ON Time	BPON7	BPON6	BPON5	BPON4	BPON3	BPON2	BPON1	BPON0
	R/W	R/W	R/W	R/W	R/W	R/W	R/W	R/W	R/W
	Default	0	0	0	0	0	0	0	0

BPON7-0: BEEP Output ON Time Setting (Table 51, Table 52)

Default: "00H"

Addr	Register Name	D7	D6	D5	D4	D3	D2	D1	D0
17H	BEEP OFF Time	BPOFF7	BPOFF6	BPOFF5	BPOFF4	BPOFF3	BPOFF2	BPOFF1	BPOFF0
	R/W	R/W	R/W	R/W	R/W	R/W	R/W	R/W	R/W
	Default	0	0	0	0	0	0	0	0

BPOFF7-0: BEEP Output OFF Time Setting (Table 53, Table 54)

Default: "00H"

Addr	Register Name	D7	D6	D5	D4	D3	D2	D1	D0
18H	BEEP Repeat Count	0	BPTM6	BPTM5	BPTM4	BPTM3	BPTM2	BPTM1	BPTM0
	R/W	R	R/W	R/W	R/W	R/W	R/W	R/W	R/W
	Default	0	0	0	0	0	0	0	0

BPTM6-0: BEEP Repeat Time Setting (Table 55)

Default: "00H"

Addr	Register Name	D7	D6	D5	D4	D3	D2	D1	D0
19H	BEEP Volume Control	BPOUT	0	0	0	BPLVL3	BPLVL2	BPLVL1	BPLVL0
	R/W	R/W	R	R	R	R/W	R/W	R/W	R/W
	Default	0	0	0	0	0	0	0	0

BPLVL3-0: BEEP Output Level Setting (Table 56)

Default: "0H" (0dB)

BPOUT: BEEP Output ON/OFF Control

0: OFF (default)

1: ON

Beep is output for the number of times, that is selected by BPTM6-0 bits, by setting BPOUT bit = "1" while BPCNT bit = "0". BPOUT bit is automatically set to "0" when BEEP output is finished.

Addr	Register Name	D7	D6	D5	D4	D3	D2	D1	D0
1AH	Video Control	0	0	0	0	VG1	VG0	PMCP	PMV
	R/W	R	R	R	R	R/W	R/W	R/W	R/W
	Default	0	0	0	0	0	0	0	0

PMV: Video Block Power Management

0: Power down (default)

1: Power up

PMCP: Charge Pump Block Power Management

0: Power down (default)

1: Power up

VG1-0: Video Amplifier Gain Select

VG1-0 bits	GAIN
00	+6dB
01	+9dB
10	+12dB
11	+16.5dB

(default)

Table 63. Video Signal Gain Setting

Addr	Register Name	D7	D6	D5	D4	D3	D2	D1	D0
1BH	HPF Filter Control	0	0	0	0	0	HPFC1	HPFC0	HPFAD
	R/W	R	R	R	R	R	R/W	R/W	R/W
	Default	0	0	0	0	0	0	0	1

HPFAD: HPF1 Control of ADC

0: OFF

1: ON (default)

When HPFAD bit is "1", the settings of HPFC1-0 bits are enabled. When HPFAD bit is "0", HPFAD block is through (0dB).

When PMADL bit = "1" or PMADR bit = "1", set HPFAD bit to "1".

HPFC1-0: Cut-off Frequency Setting of HPF1 (ADC) (Table 25)

Default: "00" (3.7Hz @ fs = 48kHz)

Addr	Register Name	D7	D6	D5	D4	D3	D2	D1	D0
1CH	Digital Filter Select 1	0	0	LPF	HPF	EQ0	GN1	GN0	FIL3
	R/W	R	R	R/W	R/W	R/W	R/W	R/W	R/W
	Default	0	0	0	0	0	0	0	1

FIL3: Stereo Emphasis Filter Control

0: OFF

1: ON (default)

When FIL3 bit = "1", settings of F3A13-0 and F3B13-0 bits are enabled.

GN1-0: Gain Block Gain Setting (Table 26)

Default: "00" (0dB)

EQ0: Gain Correction Filter (EQ0) Control

0: OFF (default)

1: ON

When EQ0 bit = "1", settings of E0A15-0, E0B13-0 and E0C15-0 bits are enabled. When EQ0 bit = "0", the audio data passes this block by 0dB gain.

HPF: HPF3 Coefficient Setting Enable

0: OFF (default)

1: ON

When HPF bit is "1", settings of F1A13-0 and F1B13-0 bits are enabled. When HPF bit is "0", the audio data passes this block by 0dB gain.

LPF: LPF Coefficient Setting Enable

0: OFF (default)

1: ON

When LPF bit is "1", settings of F2A13-0 and F2B13-0 bits are enabled. When LPF bit is "0", the audio data passes this block by 0dB gain.

Addr	Register Name	D7	D6	D5	D4	D3	D2	D1	D0
1DH	Digital Filter Control	0	0	0	0	DSPBP	PFDAC	ADCPF	PFSDO
	R/W	R	R	R	R	R/W	R/W	R/W	R/W
	Default	0	0	0	0	0	0	1	1

PFSDO: SDTO Output Signal Select

0: ADC (+ 1st HPF) Output

1: Programmable Filter / ALC Output (default)

ADCPF: Programmable Filter / ALC Input Signal Select

0: SDTI

1: ADC Output (default)

PFDAC: DAC Input Signal Select

0: SDTI (default)

1: Programmable Filter / ALC Output

DSPBP: DSP Bypass Mode Enable

0: Disable (default)

1: Enable DSP block is bypassed.

Addr	Register Name	D7	D6	D5	D4	D3	D2	D1	D0
1EH	HPF2 Co-efficient 0	F1A7	F1A6	F1A5	F1A4	F1A3	F1A2	F1A1	F1A0
1FH	HPF2 Co-efficient 1	0	0	F1A13	F1A12	F1A11	F1A10	F1A9	F1A8
20H	HPF2 Co-efficient 2	F1B7	F1B6	F1B5	F1B4	F1B3	F1B2	F1B1	F1B0
21H	HPF2 Co-efficient 3	0	0	F1B13	F1B12	F1B11	F1B10	F1B9	F1B8
R/W		R/W	R/W	R/W	R/W	R/W	R/W	R/W	R/W
Default		F1A13-0 bits = 0x1FB0, F1B13-0 bits = 0x209F							

F1A13-0, F1B13-0: HPF3 Coefficient (14bit x 2)

Default: F1A13-0 bits = 0x1FB0, F1B13-0 bits = 0x209F

fc = 150Hz@fs=48kHz

Addr	Register Name	D7	D6	D5	D4	D3	D2	D1	D0
22H	LPF Co-efficient 0	F2A7	F2A6	F2A5	F2A4	F2A3	F2A2	F2A1	F2A0
23H	LPF Co-efficient 1	0	0	F2A13	F2A12	F2A11	F2A10	F2A9	F2A8
24H	LPF Co-efficient 2	F2B7	F2B6	F2B5	F2B4	F2B3	F2B2	F2B1	F2B0
25H	LPF Co-efficient 3	0	0	F2B13	F2B12	F2B11	F2B10	F2B9	F2B8
R/W		R/W	R/W	R/W	R/W	R/W	R/W	R/W	R/W
Default		0	0	0	0	0	0	0	0

F2A13-0, F2B13-0: LPF Coefficient (14bit x 2)

Default: "0000H"

Addr	Register Name	D7	D6	D5	D4	D3	D2	D1	D0
26H	FIL3 Co-efficient 0	F3A7	F3A6	F3A5	F3A4	F3A3	F3A2	F3A1	F3A0
27H	FIL3 Co-efficient 1	F3AS	0	F3A13	F3A12	F3A11	F3A10	F3A9	F3A8
28H	FIL3 Co-efficient 2	F3B7	F3B6	F3B5	F3B4	F3B3	F3B2	F3B1	F3B0
29H	FIL3 Co-efficient 3	0	0	F3B13	F3B12	F3B11	F3B10	F3B9	F3B8
2AH	EQ0-efficient 0	E0A7	E0A6	E0A5	E0A4	E0A3	E0A2	E0A1	E0A0
2BH	EQ0-efficient 1	E0A15	E0A14	E0A13	E0A12	E0A11	E0A10	E0A9	E0A8
2CH	EQ0-efficient 2	E0B7	E0B6	E0B5	E0B4	E0B3	E0B2	E0B1	E0B0
2DH	EQ0-efficient 3	0	0	E0B13	E0B12	E0B11	E0B10	E0B9	E0B8
2EH	EQ0-efficient 4	E0C7	E0C6	E0C5	E0C4	E0C3	E0C2	E0C1	E0C0
2FH	EQ0-efficient 5	E0C15	E0C14	E0C13	E0C12	E0C11	E0C10	E0C9	E0C8
R/W		R/W	R/W	R/W	R/W	R/W	R/W	R/W	R/W
Default		0	0	0	0	0	0	0	0

F3A13-0, F3B13-0: Stereo Emphasis FIL3 Coefficient (14bit x 2)

Default: "0000H"

F3AS: Stereo Emphasis FIL3 Select

0: HPF (default)

1: LPF

E0A15-0, E0B13-0, E0C15-C0: Gain Compensation Filter Coefficient (16bit x 2 + 14bit x 1)

Default: "0000H"

Addr	Register Name	D7	D6	D5	D4	D3	D2	D1	D0
30H	Digital Filter Select 2	0	0	0	EQ5	EQ4	EQ3	EQ2	EQ1
	R/W	R	R	R	R/W	R/W	R/W	R/W	R/W
	Default	0	0	0	0	0	0	0	0

EQ1: Equalizer 1 Coefficient Setting Enable

0: Disable (default)

1: Enable

When EQ1 bit = "1", settings of E1A15-0, E1B15-0 and E1C15-0 bits are enabled. When EQ1 bit = "0", the audio data passes this block by 0dB gain.

EQ2: Equalizer 2 Coefficient Setting Enable

0: Disable (default)

1: Enable

When EQ2 bit = "1", settings of E2A15-0, E2B15-0 and E2C15-0 bits are enabled. When EQ2 bit = "0", the audio data passes this block by 0dB gain.

EQ3: Equalizer 3 Coefficient Setting Enable

0: Disable (default)

1: Enable

When EQ3 bit = "1", settings of E3A15-0, E3B15-0 and E3C15-0 bits are enabled. When EQ3 bit = "0", the audio data passes this block by 0dB gain.

EQ4: Equalizer 4 Coefficient Setting Enable

0: Disable (default)

1: Enable

When EQ4 bit = "1", settings of E4A15-0, E4B15-0 and E4C15-0 bits are enabled. When EQ4 bit = "0", the audio data passes this block by 0dB gain.

EQ5: Equalizer 5 Coefficient Setting Enable

0: Disable (default)

1: Enable

When EQ5 bit = "1", settings of E5A15-0, E5B15-0 and E5C15-0 bits are enabled. When EQ5 bit = "0", the audio data passes this block by 0dB gain.

Addr	Register Name	D7	D6	D5	D4	D3	D2	D1	D0
31H	Check Sum	SUM7	SUM6	SUM5	SUM4	SUM3	SUM2	SUM1	SUM0
	R/W	R	R	R	R	R	R	R	R
	Default	0	0	0	0	0	0	0	0

SUM7-0: Checksum Read

Addr	Register Name	D7	D6	D5	D4	D3	D2	D1	D0
32H	E1 Co-efficient 0	E1A7	E1A6	E1A5	E1A4	E1A3	E1A2	E1A1	E1A0
33H	E1 Co-efficient 1	E1A15	E1A14	E1A13	E1A12	E1A11	E1A10	E1A9	E1A8
34H	E1 Co-efficient 2	E1B7	E1B6	E1B5	E1B4	E1B3	E1B2	E1B1	E1B0
35H	E1 Co-efficient 3	E1B15	E1B14	E1B13	E1B12	E1B11	E1B10	E1B9	E1B8
36H	E1 Co-efficient 4	E1C7	E1C6	E1C5	E1C4	E1C3	E1C2	E1C1	E1C0
37H	E1 Co-efficient 5	E1C15	E1C14	E1C13	E1C12	E1C11	E1C10	E1C9	E1C8
38H	E2 Co-efficient 0	E2A7	E2A6	E2A5	E2A4	E2A3	E2A2	E2A1	E2A0
39H	E2 Co-efficient 1	E2A15	E2A14	E2A13	E2A12	E2A11	E2A10	E2A9	E2A8
3AH	E2 Co-efficient 2	E2B7	E2B6	E2B5	E2B4	E2B3	E2B2	E2B1	E2B0
3BH	E2 Co-efficient 3	E2B15	E2B14	E2B13	E2B12	E2B11	E2B10	E2B9	E2B8
3CH	E2 Co-efficient 4	E2C7	E2C6	E2C5	E2C4	E2C3	E2C2	E2C1	E2C0
3DH	E2 Co-efficient 5	E2C15	E2C14	E2C13	E2C12	E2C11	E2C10	E2C9	E2C8
3EH	E3 Co-efficient 0	E3A7	E3A6	E3A5	E3A4	E3A3	E3A2	E3A1	E3A0
3FH	E3 Co-efficient 1	E3A15	E3A14	E3A13	E3A12	E3A11	E3A10	E3A9	E3A8
40H	E3 Co-efficient 2	E3B7	E3B6	E3B5	E3B4	E3B3	E3B2	E3B1	E3B0
41H	E3 Co-efficient 3	E3B15	E3B14	E3B13	E3B12	E3B11	E3B10	E3B9	E3B8
42H	E3 Co-efficient 4	E3C7	E3C6	E3C5	E3C4	E3C3	E3C2	E3C1	E3C0
43H	E3 Co-efficient 5	E3C15	E3C14	E3C13	E3C12	E3C11	E3C10	E3C9	E3C8
44H	E4 Co-efficient 0	E4A7	E4A6	E4A5	E4A4	E4A3	E4A2	E4A1	E4A0
45H	E4 Co-efficient 1	E4A15	E4A14	E4A13	E4A12	E4A11	E4A10	E4A9	E4A8
46H	E4 Co-efficient 2	E4B7	E4B6	E4B5	E4B4	E4B3	E4B2	E4B1	E4B0
47H	E4 Co-efficient 3	E4B15	E4B14	E4B13	E4B12	E4B11	E4B10	E4B9	E4B8
48H	E4 Co-efficient 4	E4C7	E4C6	E4C5	E4C4	E4C3	E4C2	E4C1	E4C0
49H	E4 Co-efficient 5	E4C15	E4C14	E4C13	E4C12	E4C11	E4C10	E4C9	E4C8
4AH	E5 Co-efficient 0	E5A7	E5A6	E5A5	E5A4	E5A3	E5A2	E5A1	E5A0
4BH	E5 Co-efficient 1	E5A15	E5A14	E5A13	E5A12	E5A11	E5A10	E5A9	E5A8
4CH	E5 Co-efficient 2	E5B7	E5B6	E5B5	E5B4	E5B3	E5B2	E5B1	E5B0
4DH	E5 Co-efficient 3	E5B15	E5B14	E5B13	E5B12	E5B11	E5B10	E5B9	E5B8
4EH	E5 Co-efficient 4	E5C7	E5C6	E5C5	E5C4	E5C3	E5C2	E5C1	E5C0
4FH	E5 Co-efficient 5	E5C15	E5C14	E5C13	E5C12	E5C11	E5C10	E5C9	E5C8
	R/W	R/W	R/W	R/W	R/W	R/W	R/W	R/W	R/W
	Default	0	0	0	0	0	0	0	0

E1A15-0, E1B15-0, E1C15-0: Equalizer 1 Coefficient (16bit x3)
Default: "0000H"

E2A15-0, E2B15-0, E2C15-0: Equalizer 2 Coefficient (16bit x3)
Default: "0000H"

E3A15-0, E3B15-0, E3C15-0: Equalizer 3 Coefficient (16bit x3)
Default: "0000H"

E4A15-0, E4B15-0, E4C15-0: Equalizer 4 Coefficient (16bit x3)
Default: "0000H"

E5A15-0, E5B15-0, E5C15-0: Equalizer 5 Coefficient (16bit x3)
Default: "0000H"

SYSTEM DESIGN

Figure 75 ~ Figure 77 show the system connection diagram. An evaluation board (AKD4955) is available for fast evaluation as well as suggestions for peripheral circuitry.

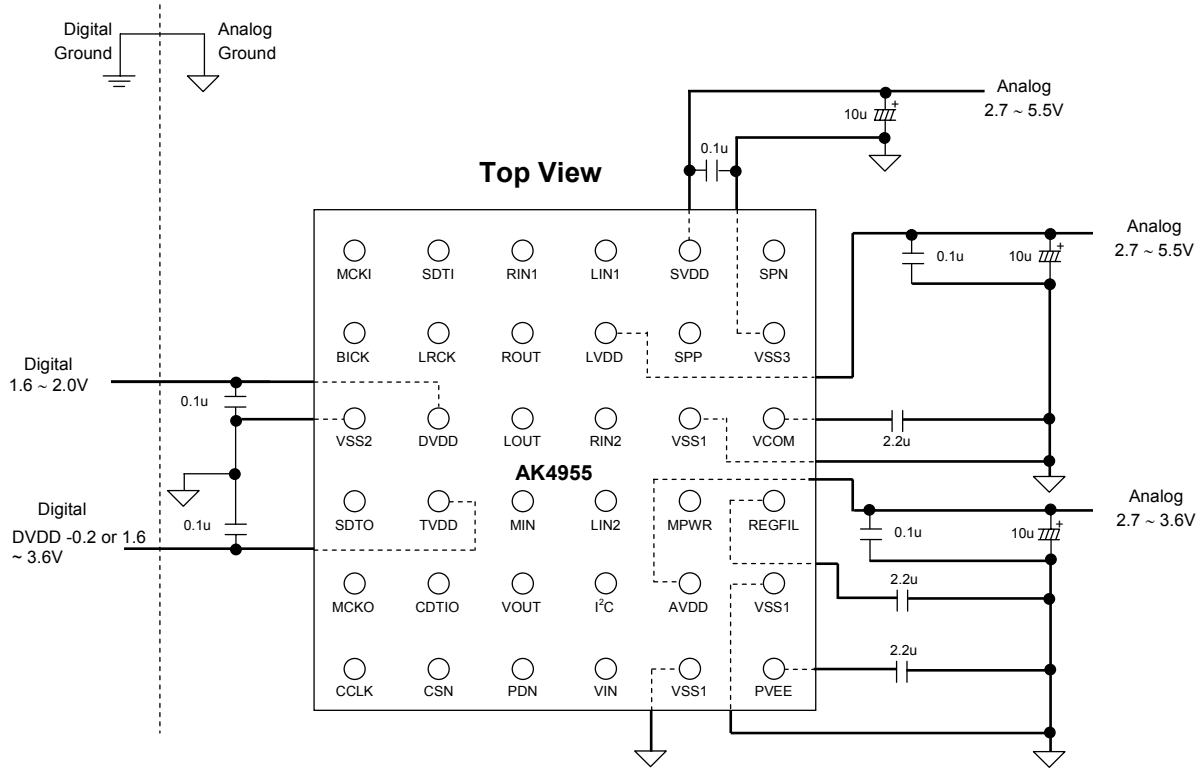

Figure 75. Power Supplies Connection Diagram

Notes:

- VSS1, VSS2, and VSS3 of the AK4955 must be distributed separately from the ground of external controllers.

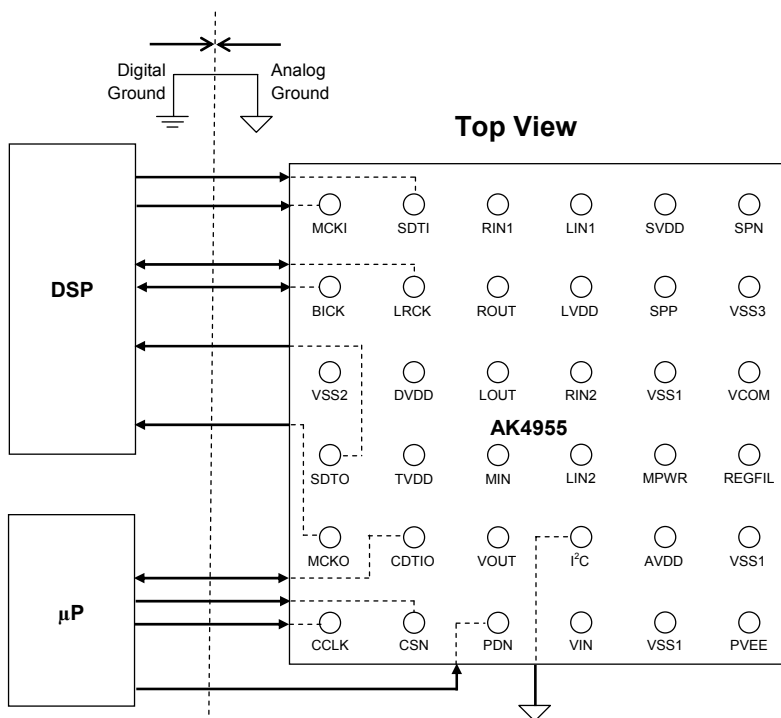

Figure 76. Digital Block Connection Diagram (3-wire Serial Mode; I2C pin = “L”),

Note:

- All digital input pins must not be allowed to float.
- When the AK4955 is used in master mode, LRCK and BICK pins are floating before M/S bit is changed to “1”. Therefore, a pull-up or pull-down resistor around 100kΩ must be connected to LRCK and BICK pins of the AK4955.

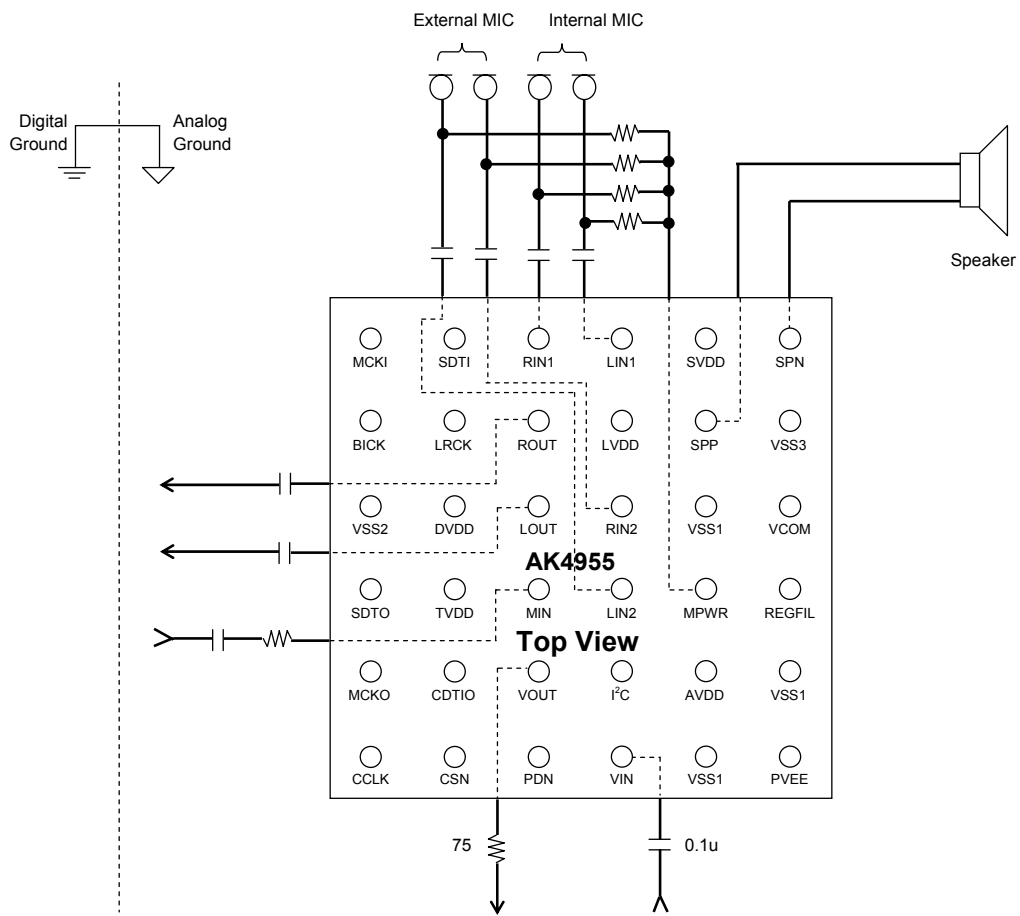

Figure 77. Audio and Video Input/Output Connection (External Resistance Mode; BPM1-0 bits = “01”)

1. Grounding and Power Supply Decoupling

The AK4955 requires careful attention to power supply and grounding arrangements. If AVDD, DVDD, TVDD, SVDD and LVDD are supplied separately, the power-up sequence is not critical. VSS1, VSS2, and VSS3 of the AK4955 must be connected to the analog ground plane. System analog ground and digital ground should be wired separately and connected together as close as possible to where the supplies are brought onto the printed circuit board. Decoupling capacitors must be as near to the AK4955 as possible, with the small value ceramic capacitor being the nearest.

2. Internal Regulated Voltage Power Supply

VCOM is a signal ground of this chip. A 2.2 μ F electrolytic capacitor in parallel with a 0.1 μ F ceramic capacitor attached to the VSS1 pin eliminates the effects of high frequency noise. No load current may be drawn from the VCOM pin. All signals, especially clocks, should be kept away from the VCOM pin in order to avoid unwanted coupling into the AK4955.

3. Analog Inputs

The Mic and Line inputs supports single-ended. The input signal range scales with nominally at typ. 2.07Vpp (@ MGAIN = 0dB), centered around the internal signal ground (typ. 1.15V). Usually the input signal is AC coupled with a capacitor. The cut-off frequency is $f_c = 1/(2\pi RC)$. The AK4955 can accept input voltages from VSS1 to AVDD.

6. Analog Outputs

The input data format for the DAC is 2's complement. The output voltage is a positive full scale for 7FFFFFFH (@24bit) and a negative full scale for 800000H (@24bit). The ideal output is VCOM voltage for 000000H (@24bit data). The common voltage of stereo lineout is typ. 2.52Vpp centered on 1.5V (typ) (LVCM1-0 bits = "01"). The speaker outputs are centered on SVDD/2 (typ).

CONTROL SEQUENCE

■ Clock Set up

When any circuits of the AK4955 are powered-up, the clocks must be supplied.

1. PLL Master Mode

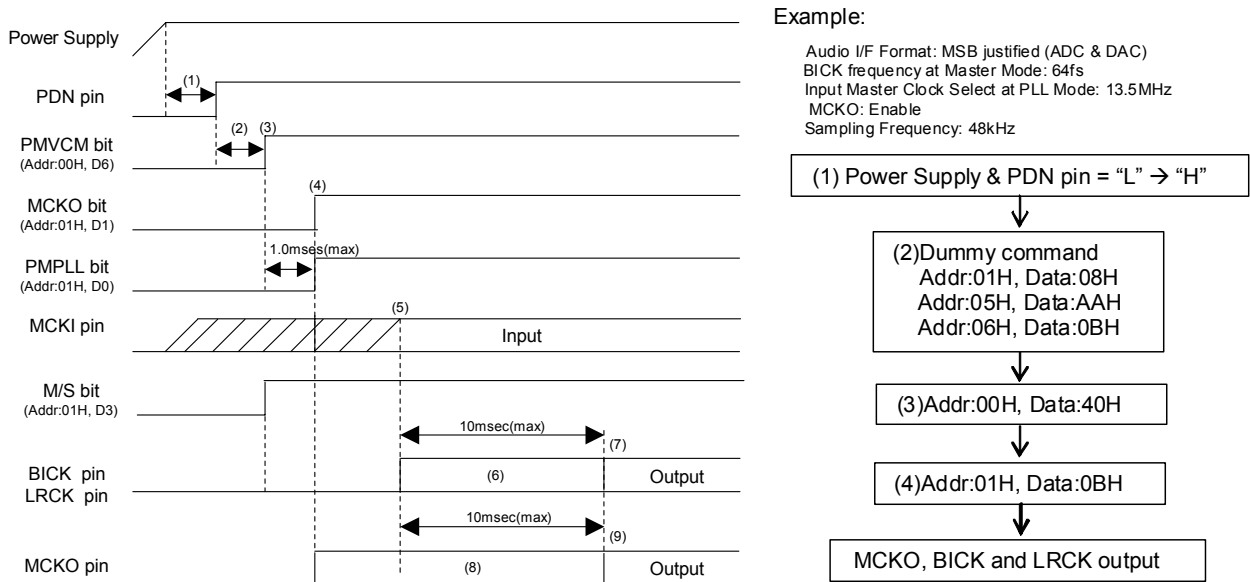

Figure 78. Clock Set Up Sequence (1)

< Example >

- (1) After Power Up, PDN pin "L" → "H".
"L" time of 180ns or more is needed to reset the AK4955.
- (2) After Dummy Command input, M/S, DIF1-0, BCKO, PLL3-0, FS3-0 and PS1-0 bits must be set during this period.
- (3) Power Up VCOM and Regulator: PMVCM bit = "0" → "1"
VCOM and Regulator must first be powered-up before the other block operates. Power up time is 0.4ms (typ) and 1.0ms (max) when both capacitances of an external capacitor for the VCOM and REGFIL pins are 2.2μF.
- (4) In case of using MCKO output: MCKO bit = "1"
In case of not using MCKO output: MCKO bit = "0"
- (5) PLL starts after PMPLL bit changes from "0" to "1" and MCKI is supplied from an external source, and PLL lock time is 10ms (max).
- (6) BICK pin outputs "H" and LRCK pin outputs "L" during this period.
- (7) The AK4955 starts to output the LRCK and BICK clocks after the PLL became stable. Then normal operation starts.
- (8) An invalid frequency is output from the MCKO pin during this period if MCKO bit = "1".
- (9) A normal clock is output from the MCKO pin after the PLL is locked if MCKO bit = "1".

2. PLL Slave Mode (BICK pin)

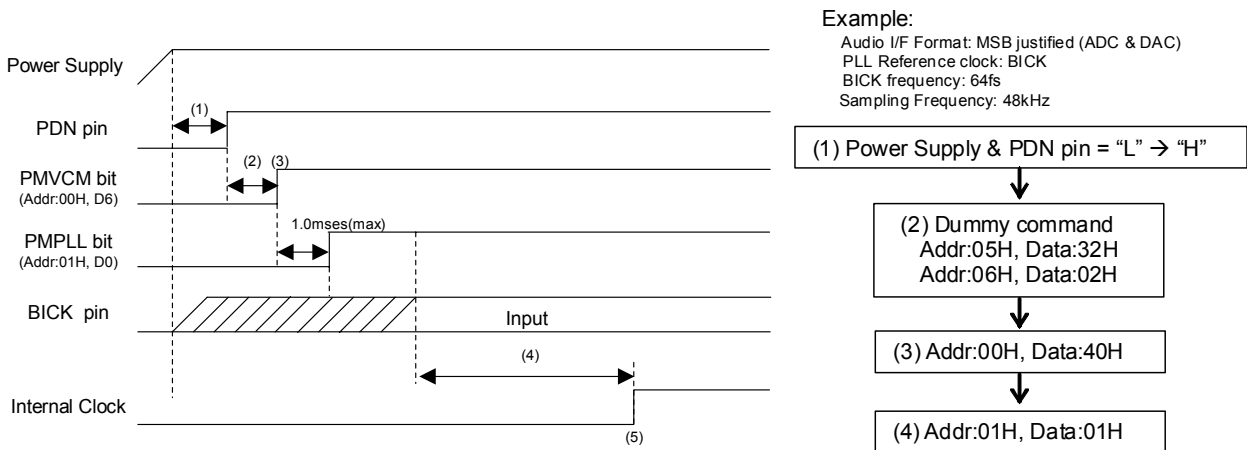

Figure 79. Clock Set Up Sequence (2)

<Example>

- (1) After Power Up: PDN pin "L" → "H"
 "L" time of 180ns or more is needed to reset the AK4955.
- (2) After Dummy Command input, DIF1-0, PLL3-0, and FS3-0 bits must be set during this period.
- (3) Power Up VCOM and Regulator: PMVCM bit = "0" → "1"
 VCOM and Regulator must first be powered-up before the other block operates. Power up time is 0.4ms (typ) and 1.0ms (max) when both capacitances of an external capacitor for the VCOM and REGFIL pins are 2.2μF.
- (4) PLL starts after the PMPLL bit changes from "0" to "1" and PLL reference clock (BICK pin) is supplied. PLL lock time is 2ms (max) when BICK is a PLL reference clock.
- (5) Normal operation starts after that the PLL is locked.

3. PLL Slave Mode (MCKI pin)

Example:

Audio I/F Format: MSB justified (ADC & DAC)
 Input Master Clock Select at PLL Mode: 13.5MHz
 MCKO: Enable
 Sampling Frequency: 48kHz

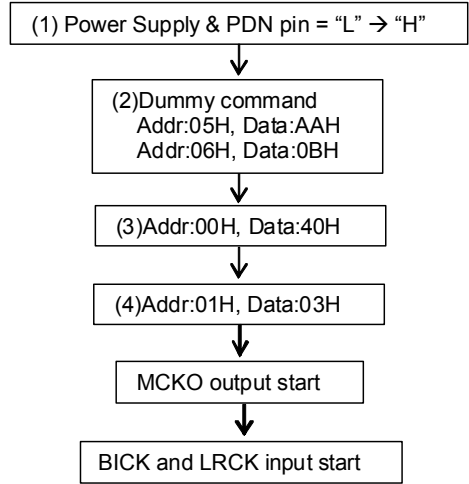
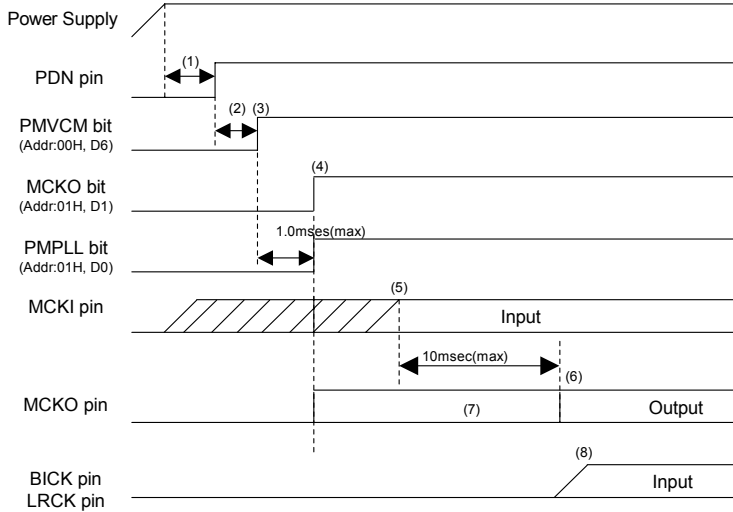

Figure 80. Clock Set Up Sequence (3)

<Example>

- (1) After Power Up: PDN pin "L" → "H"
 "L" time of 180ns or more is needed to reset the AK4955.
- (2) After Dummy Command input, DIF1-0, PLL3-0, FS3-0 and PS1-0 bits must be set during this period.
- (3) Power Up VCOM and Regulator: PMVCM bit = "0" → "1"
 VCOM and Regulator must first be powered-up before the other block operates. Power up time is 0.4ms (typ) and 1.0ms (max) when both capacitances of an external capacitor for the VCOM and REGFIL pins are 2.2μF.
- (4) Enable MCKO output: MCKO bit = "1"
- (5) PLL starts after that the PMPLL bit changes from "0" to "1" and PLL reference clock (MCKI pin) is supplied. PLL lock time is 10ms (max).
- (6) A normal clock is output from MCKO after PLL is locked.
- (7) An invalid frequency is output from MCKO during this period.
- (8) BICK and LRCK clocks must be synchronized with MCKO clock.

4. EXT Slave Mode

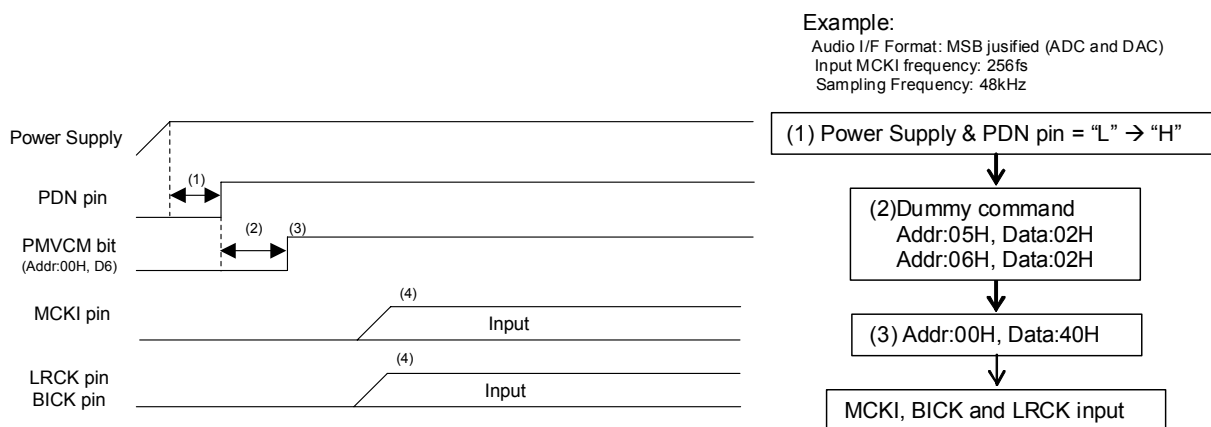
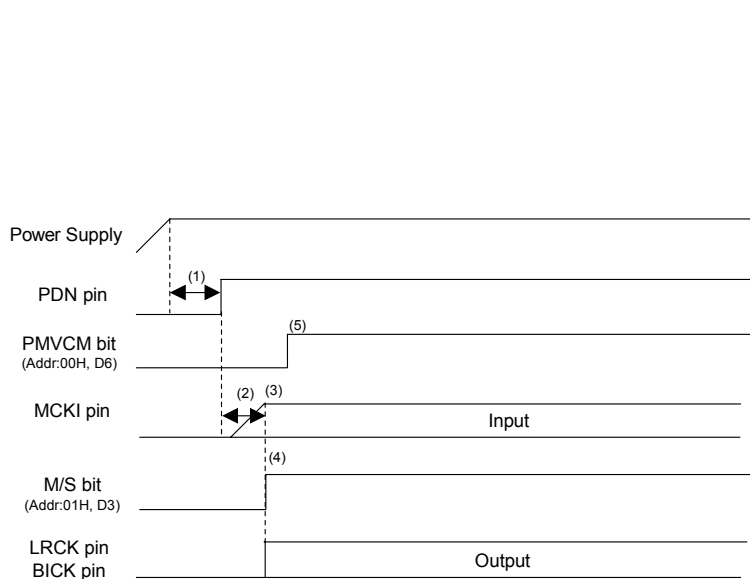

Figure 81. Clock Set Up Sequence (4)

<Example>

- (1) After Power Up: PDN pin "L" → "H"
 "L" time of 180ns or more is needed to reset the AK4955.
- (2) After Dummy Command input, DIF1-0 and FS3-0 bits must be set during this period.
- (3) Power Up VCOM and Regulator: PMVCM bit = "0" → "1"
 VCOM and Regulator must first be powered-up before the other block operates. Power up time is 0.4ms (typ) and 1.0ms (max) when both capacitances of an external capacitor for the VCOM and REGFIL pins are 2.2μF.
- (4) Normal operation starts after the MCKI, LRCK and BICK are supplied.

5. EXT Master Mode



Example:

Audio I/F Format: MSB justified (ADC and DAC)
 Input MCKI frequency: 256fs
 Sampling Frequency: 48kHz
 BCKO: 64fs

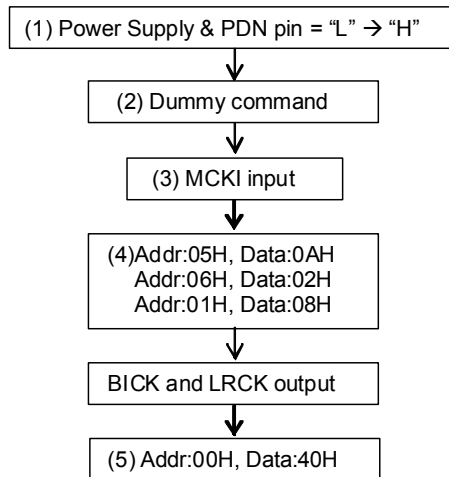

Figure 82. Clock Set Up Sequence (5)

<Example>

- (1) After Power Up: PDN pin “L” → “H”
 “L” time of 180ns or more is needed to reset the AK4955.
- (2) Dummy Command must be input during this period.
- (3) MCKI is supplied.
- (4) After DIF1-0, BCKO and FS3-0 bits are set. M/S bit should be set to “1”. Then LRCK and BICK are output.
- (5) Power Up VCOM and Regulator: PMVCM bit = “0” → “1”
 VCOM and Regulator must first be powered-up before the other block operates. Power up time is 0.4ms (typ) and 1.0ms (max) when both capacitances of an external capacitor for the VCOM and REGFIL pins are 2.2μF.

■ DSP Block

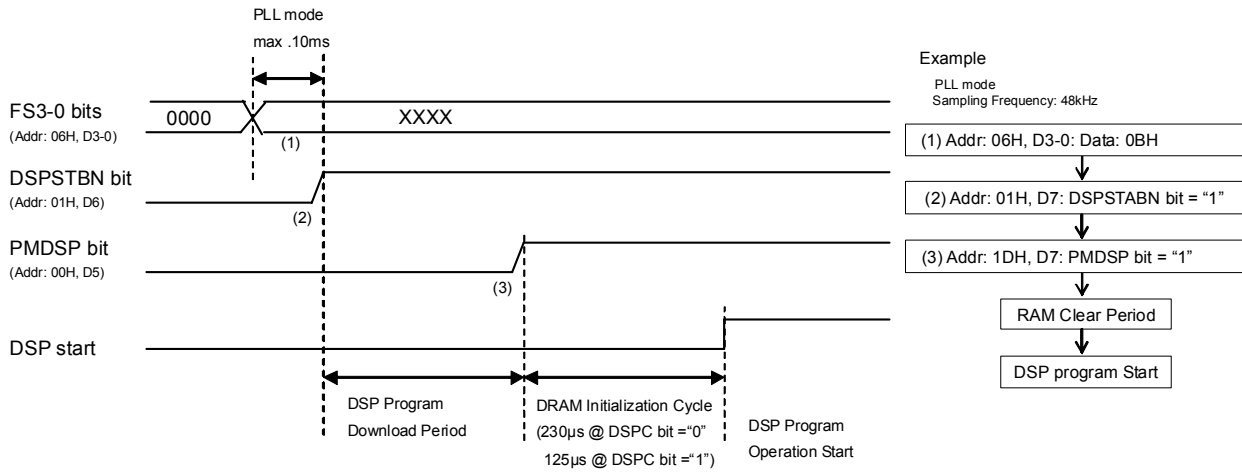

Figure 83. DSP Sequence

At first, clocks should be supplied according to “Clock Set Up” sequence.

- (1) In PLL mode, access the DSP with an interval of PLL lock time (max. 10ms) after changing the sampling frequency.
- (2) Start program download period (Addr = 01H, D6 DSPSTBN bit = “1”). Write a program to PRAM and data to CRAM during this period. There is no limit for the program download period.
- (3) Power-up the DSP (Addr = 00H, D5 PMDSP bit = “1”). DRAM initialization starts when power-up the DSP after downloading a program. DRAM initialization cycle is set by DSPC bit; max. 11LRCK≈230µs when DSPC bit = “0” (DSP: 256fs operation) and max. 6LRCK≈125µs when DSPC bit = “1” (DSP: 512fs operation).

■ MIC Input Recording (Stereo)

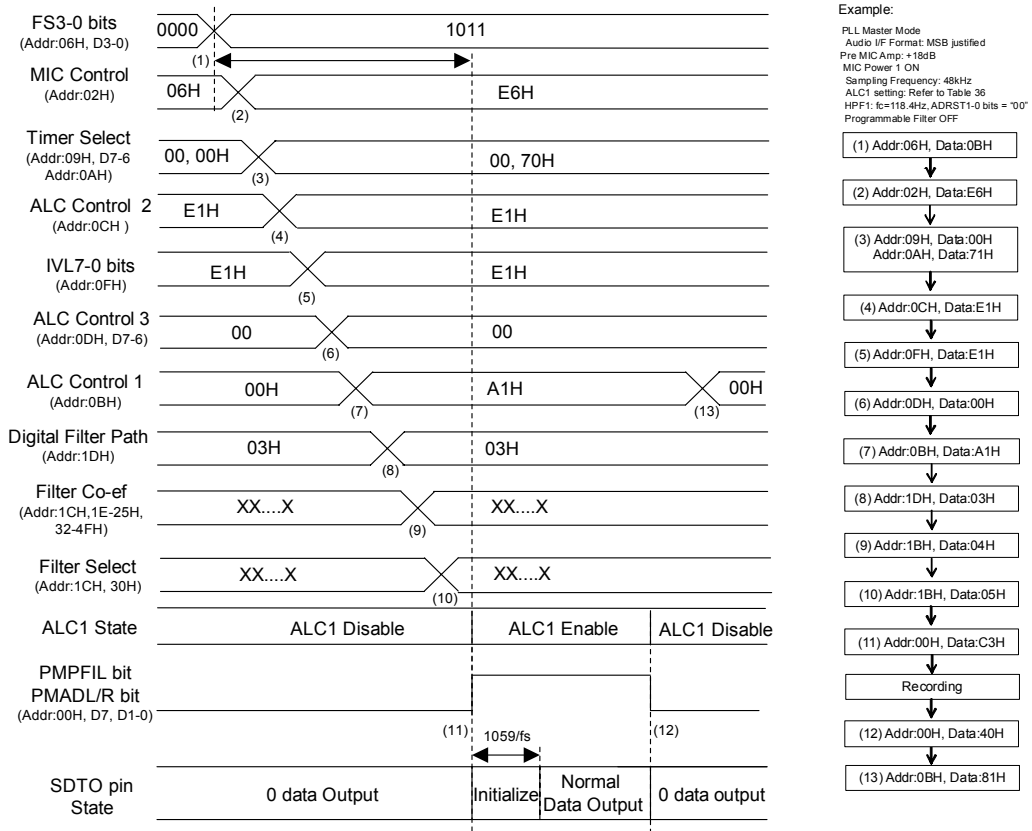

Figure 84. MIC Input Recording Sequence

<Example>

This sequence is an example of ALC1 setting at fs=48kHz. For changing the parameter of ALC, please refer to [Table 36](#). At first, clocks should be supplied according to “Clock Set Up” sequence.

- (1) Set up a sampling frequency (FS3-0 bits). When the AK4955 is the PLL mode, MIC, ADC and Programmable Filter of (11) must be powered-up in consideration of PLL lock time after a sampling frequency is changed.
- (2) Set up MIC Amp and MIC Power. (Addr = 02H)
- (3) Set up ALC1 Timer, ADRST1-0 bits (Addr = 09H, 0AH)
- (4) Set up IREF value at ALC1 (Addr = 0CH)
- (5) Set up IVOL value at ALC1 operation start (Addr = 0FH)
- (6) Set up RGAIN1-0 bits (Addr = 0DH)
- (7) Set up LMTH1-0, LMAT1-0, ZELMN, ALC1 and LFST bits (Addr = 0BH)
- (8) Set up Programmable Filter Path: PFSDO bit = ADCPF bit = “1” (Addr = 1DH)
- (9) Set up Coefficient Programmable Filter (Addr: 1CH, 1EH ~ 25H, 32H ~ 4FH)
- (10) Set up of Programmable Filter ON/OFF
- (11) Power Up ADC and Programmable Filter: PMADL = PMADR = PMPFIL bits = “0” → “1”
The initialization cycle time of ADC is 1059/fs=22ms @ fs=48kHz, ADRST1-0 bit = “00”. ADC outputs “0” data during the initialization cycle. After the ALC1 bit is set to “1”, the ALC1 operation starts from IVOL value of (5).
- (12) Power Down ADC and Programmable Filter: PMADL = PMADR = PMPFIL bits = “1” → “0”
- (13) ALC Disable: ALC1 bit = “1” → “0”

■ Digital MIC Input Recording (Stereo)

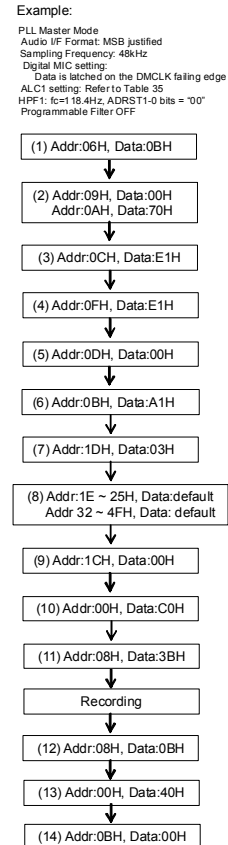
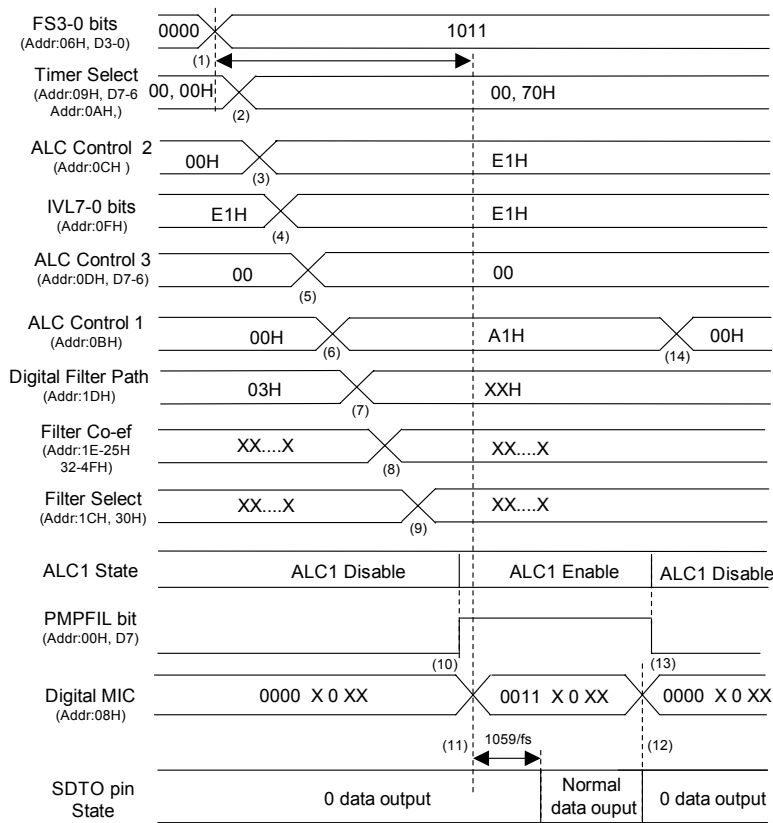

Figure 85. Digital MIC Input Recording Sequence

<Example>

This sequence is an example of ALC1 setting at fs=48kHz. For changing the parameter of ALC, please refer to Table 36. At first, clocks should be supplied according to "Clock Set Up" sequence.

- (1) Set up a sampling frequency (FS3-0 bits). When the AK4955 is PLL mode, Digital MIC of (11) and Programmable Filter of (10) must be powered-up in consideration of PLL lock time after a sampling frequency is changed.
- (2) Set up ALC1 Timer and ADRST1-0 bits (Addr = 09H, 0AH)
- (3) Set up IREF value for ALC1 (Addr = 0CH)
- (4) Set up IVOL value at ALC1 operation start (Addr = 0FH)
- (5) Set up RGAIN1-0 bits (Addr = 0DH)
- (6) Set up LMTH1-0, LMAT1-0, ZELMN, ALC1, LFST bits (Addr = 0BH)
- (7) Set up Programmable Filter Path: PFSDO bit = ADCPF bit = "1" (Addr = 1DH)
- (8) Set up Coefficient of Programmable Filter (Addr: 1EH ~ 25H, 32H ~ 4FH)
- (9) Set up Programmable Filter ON/OFF
- (10) Power Up Programmable Filter: PMPFIL bit = "0" → "1"
- (11) Set up & Power Up Digital MIC: PMDMR = PMDML bits = "0" → "1"
 The initialization cycle time of ADC is 1059/fs=22ms @ fs=48kHz, .ADRST1-0 bit = "00". ADC outputs "0" data during initialization cycle. After the ALC1 bit is set to "1", the ALC1 operation starts from IVOL value of (4).
- (12) Power Down Digital MIC: PMDMR = PMDML bits = "1" → "0"
- (13) Power Down Programmable Filter: PMPFIL bit = "1" → "0"
- (14) ALC1 Disable: ALC1 bit = "1" → "0"

■ Speaker-Amp Output

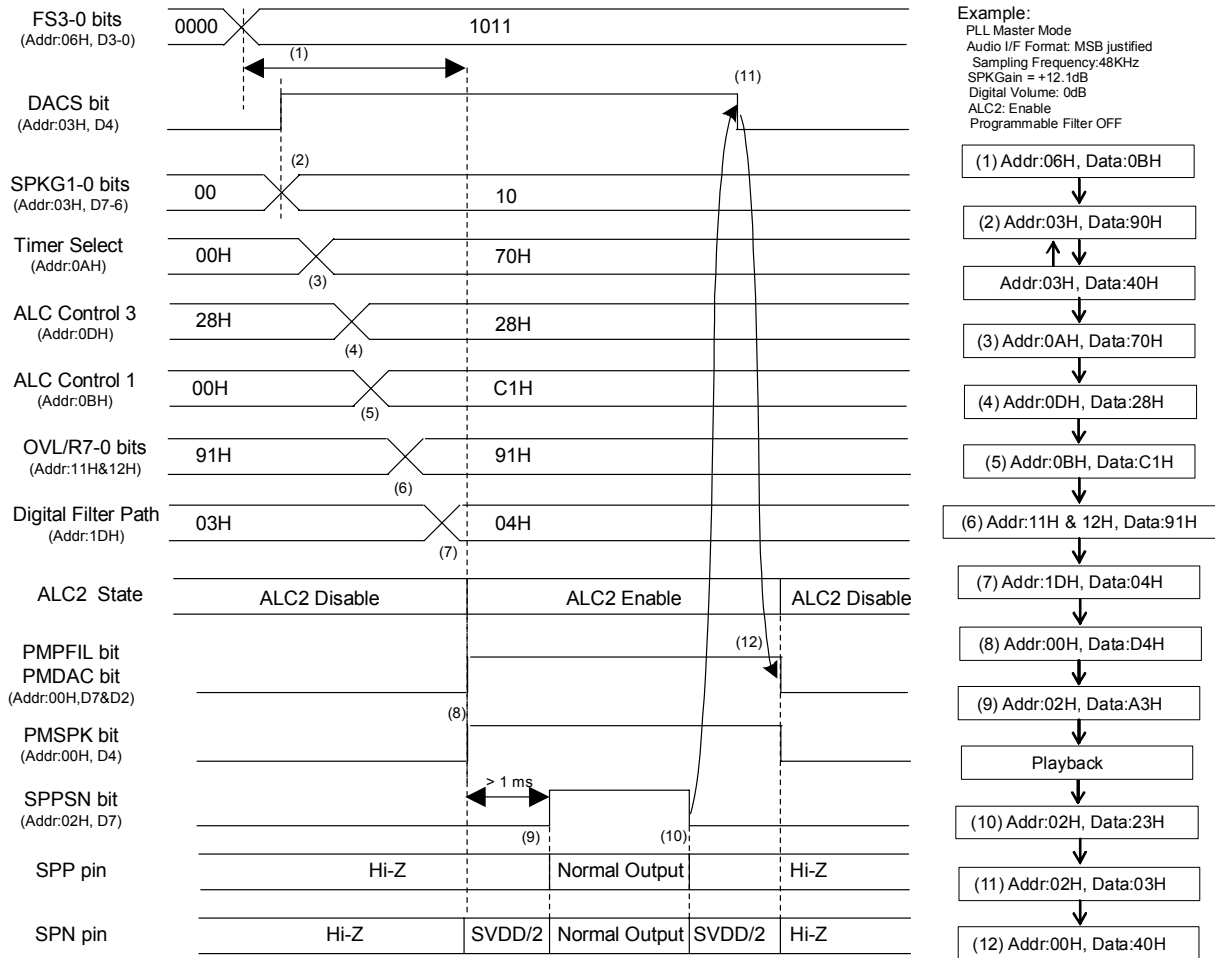

Figure 86. Speaker-Amp Output Sequence

<Example>

At first, clocks must be supplied according to “Clock Set Up” sequence.

- (1) Set up a sampling frequency (FS3-0 bits). When the AK4955 is PLL mode, DAC and Speaker-Amp of (9) must be powered-up in consideration of PLL lock time after a sampling frequency is changed.
- (2) Set up the path of DAC → SPK-Amp: DACS bit = “0” → “1”
 SPK-Amp gain setting: SPKG1-0 bits = “00” → “01”
- (3) Set up Timer Select for ALC2 (Addr = 0AH)
- (4) Set up OREF value for ALC2 and RGAIN1-0 bits (Addr = 0DH)
- (5) Set up LMTH1-0, LMAT1-0, ZELMIN, ALC2 and LFST bits (Addr = 0BH)
- (6) Set up the output digital volume (Addr = 11H, 12H)
 Set up OVOL value at ALC2 operation start. When OVOLC bit is “1” (default), OVL7-0 bits set the volume of both channels. When ALC2 bit = “0”, it could be digital volume control.
- (7) Set up Programmable Filter Path: PFDAC, ADCPF, PFSDO bits (Addr = 1DH)
- (8) Power up DAC, Programmable Filter and Speaker: PMDAC = PMPFIL = PMSPK bits = “0” → “1”
- (9) Exit the power-save-mode of Speaker-Amp: SPPSN bit = “0” → “1”
- (10) Enter Speaker-Amp Power-save-mode: SPPSN bit = “1” → “0”
- (11) Disable the path of “DAC → SPK-Amp”: DACS bit = “1” → “0”
- (12) Power down DAC, Programmable Filter and Speaker: PMDAC = PMPFIL = PMSPK bits = “1” → “0”

■ Beep Signal Output from Speaker-Amp

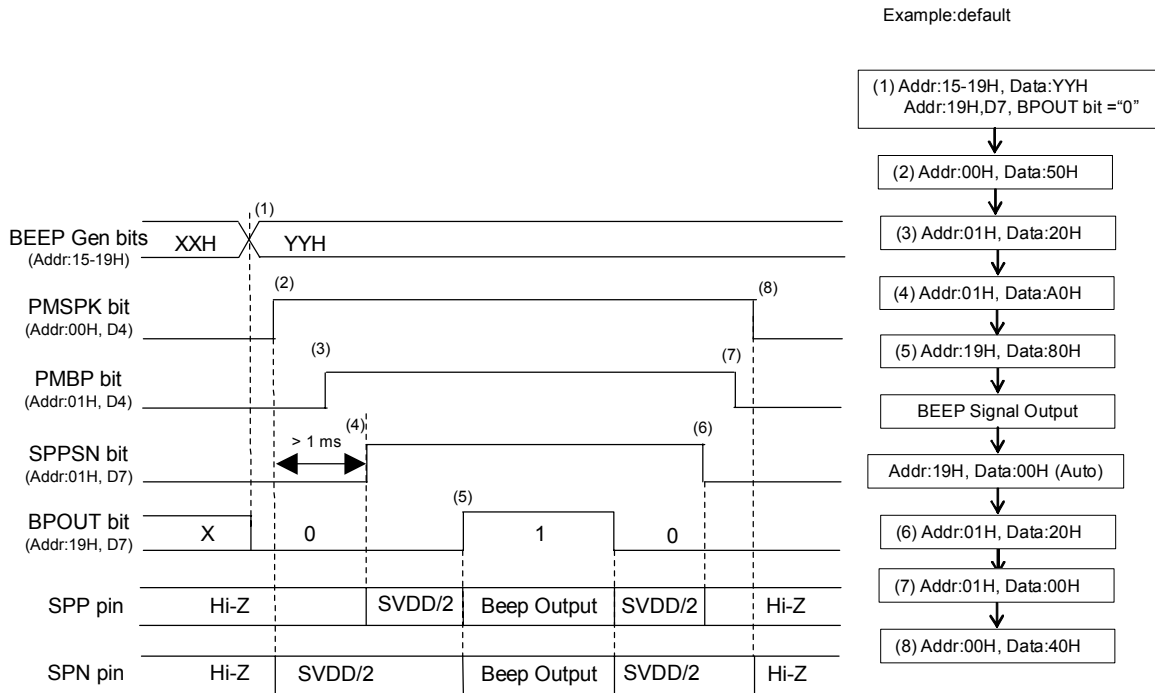

Figure 87. “BEEP Generator → Speaker-Amp” Output Sequence

<Example>

At first, clocks must be supplied according to “Clock Set Up” sequence.
 When the AK4955 is PLL mode, Speaker-Amp of (2) and BEEP Generator of (3) must be powered-up in consideration of PLL lock time after a sampling frequency is changed.

- (1) Set up BEEP Generator (Addr: 15H ~ 19H) (BPOUT bit must be set to “0”).
- (2) Power up Speaker: PMSPK bit = “0” → “1”
- (3) Power up BEEP Generator: PMBP bit = “0” → “1”
- (4) Exit the power-save-mode of Speaker-Amp: SPPSN bit = “0” → “1”
- (5) BEEP output: BPOUT bit = “0” → “1”
 After outputting data determined set times, BPOUT bit automatically returns to “0”.
- (6) Enter Speaker-Amp Power-save-mode: SPPSN bit = “1” → “0”
- (7) Power down BEEP Generator: PMBP bit = “1” → “0”
- (8) Power down Speaker: PMSPK bit = “1” → “0”

■ Stereo Line Output

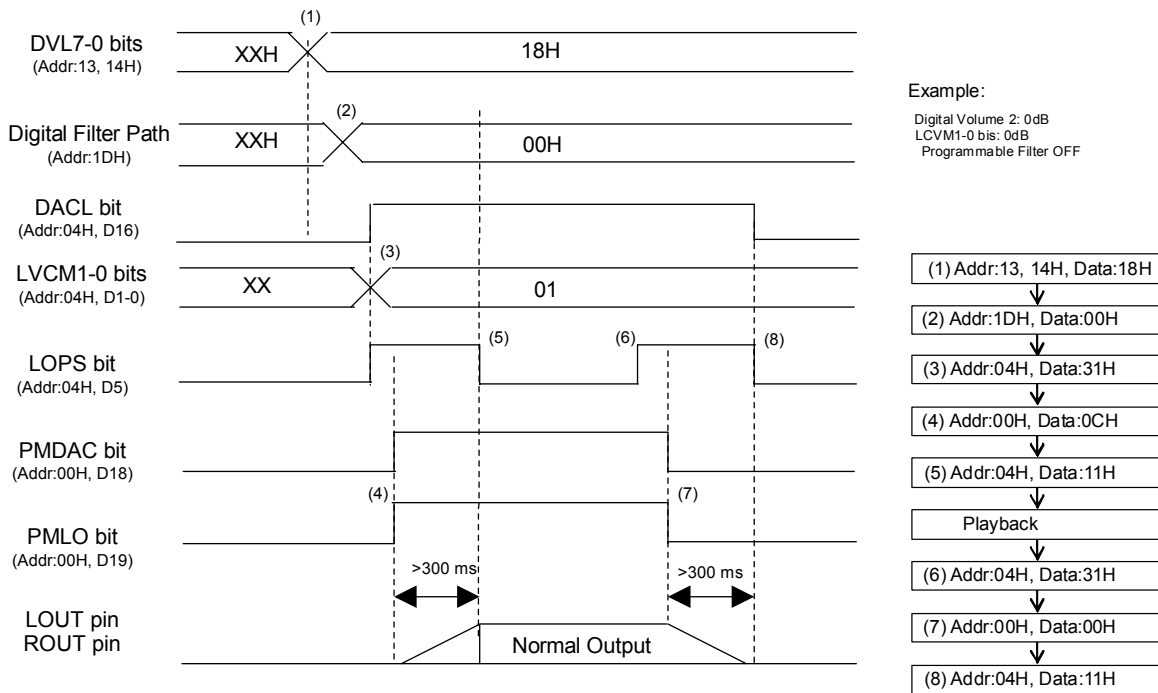

Figure 88. Stereo Lineout Sequence

<Example>

At first, clocks should be supplied according to “Clock Set Up” sequence.

- (1) Set up output digital volume 2 (Addr = 13, 14H)
- (2) Set up Programmable Filter Path (PFDAC, ADCPF and PFSDO bits). (Addr = 1DH)
- (3) Set up the path of “DAC → Stereo Line-Amp”: DACL bit = “0” → “1” (Addr = 04H)
 Set up the stereo line amplifier: LVCM1-0 bits = “xx” → “01”
 Set the stereo line amplifier to power save mode. LOPS bit = “0” → “1”
- (4) Power up Stereo Line-Amp: PMDAC = PMLO bits = “0” → “1” (Addr = 00H)
 LOUT and ROUT pins rise up to VCOM voltage after PMLO bit is changed to “1”. Rise time to 99% VCOM voltage is 300ms(max.) when $C=1\mu\text{F}$ and $R_L=10\text{k}\Omega$.
- (5) Exit power-save mode of Stereo Line-Amp: LOPS bit = “1” → “0” (Addr=04H)
 LOPS bit should be set to “0” after LOUT and ROUT pins rise up. Stereo Line-Amp goes to normal operation by setting LOPS bit to “0”.
- (6) Enter power save mode of Stereo Line-Amp: LOPS bit = “0” → “1” (Addr = 04H)
- (7) Power down DAC and Stereo Line-Amp: PMDAC=PMLO= “1” → “0”. (Addr=00H)
 LOUT and ROUT pins fall down to 1% of the VCOM voltage. Fall time is 300ms (max.) at $C=1\mu\text{F}$ and $R_L=10\text{k}\Omega$.
- (8) Disable the path of “DAC → Stereo Line-Amp”: DACL bit = “1” → “0” (Addr=04H)
 Exit power-save mode of the Stereo-Line Amp: LOPS bit = “1” → “0”
 LOPS bit should be set to “0” after LOUT and ROUT pins fall down.

■ Video Input/Output

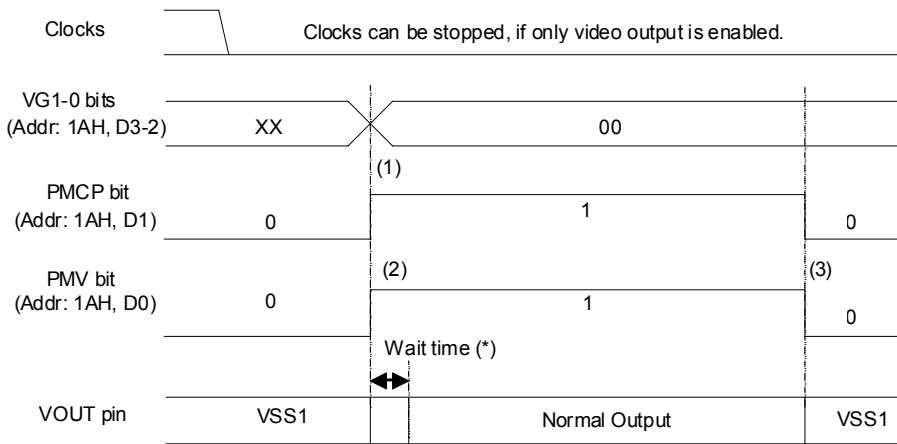
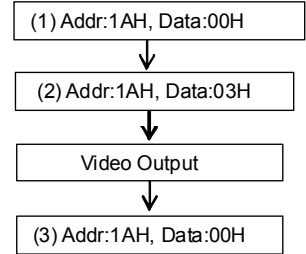

Figure 89. Video Output Sequence

Example:

Audio Function :No use
Video Gain = +6dB



<Example>

When only the video block is in operation, the clocks are not needed.

(1) Set up the video gain (VG1-0 bits).

(2) Power up Video Amp and Charge Pump: PMV, PMCP bits = “0” → “1”

(*) Wait time is the time until the video clamp circuit output is stabilized. It depends on the value of a DC cut capacitor for the VIN pin and the DC offset voltage of a video signal.

Example) In case of the input capacitor of the VIN pin is 0.1μF and the DC offset voltage is 150mV.

Wait time = (max) 180ms

(3) Power down Video Amp: PMV, PMCP bits = “0” → “1”

The VOUT pin output is stopped and becomes 0V.

■ Stop of Clock

When any circuits of the AK4955 are powered-up, the clocks must be supplied.

1. PLL Master Mode

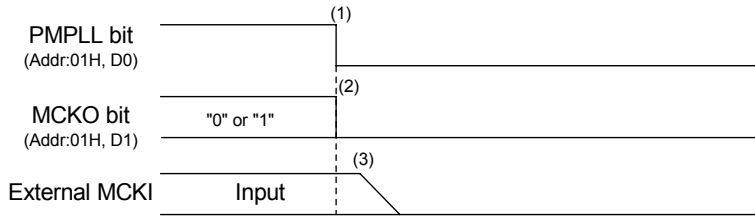

Example:

Audio I/F Format: MSB justified (ADC & DAC)
 BICK frequency at Master Mode: 64fs
 Input Master Clock Select at PLL Mode: 12.288MHz

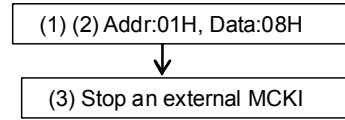
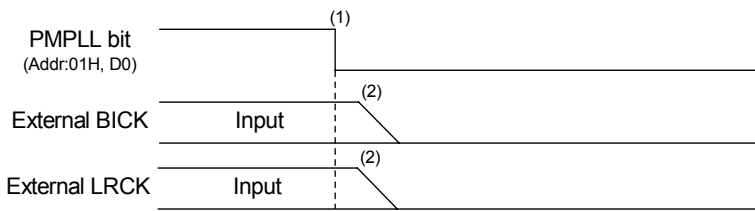

Figure 90. Clock Stopping Sequence (1)

<Example>

- (1) Power down PLL: PMPLL bit = "1" → "0"
- (2) Stop MCKO clock: MCKO bit = "1" → "0"
- (3) Stop an external master clock.

2. PLL Slave Mode (BICK pin)



Example

Audio I/F Format : MSB justified (ADC & DAC)
 PLL Reference clock: BICK
 BICK frequency: 64fs

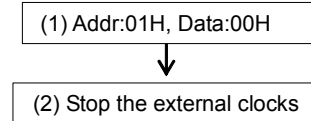

Figure 91. Clock Stopping Sequence (2)

<Example>

- (1) Power down PLL: PMPLL bit = "1" → "0"
- (2) Stop the external BICK and LRCK clocks.

3. PLL Slave (MCKI pin)

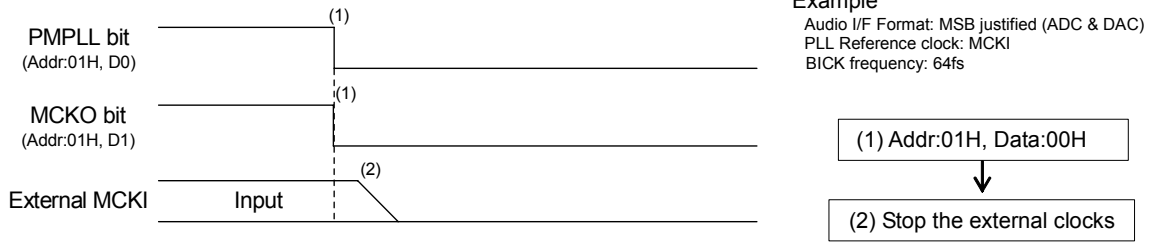

Figure 92. Clock Stopping Sequence (3)

<Example>

- (1) Power down PLL: PMPLL bit = “1” → “0”
Stop MCKO output: MCKO bit = “1” → “0”
- (2) Stop the external master clock.

4. EXT Slave Mode

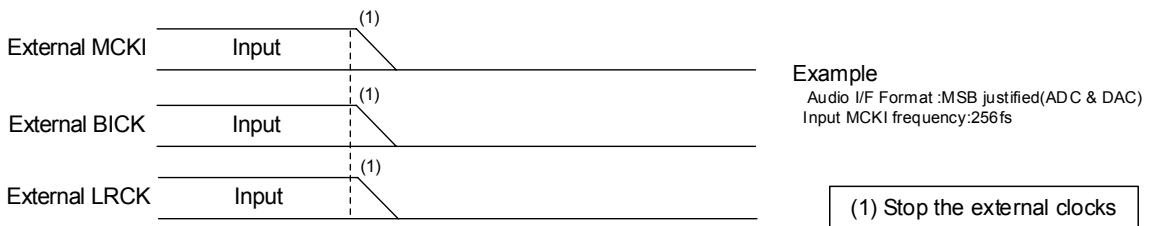

Figure 93. Clock Stopping Sequence (4)

<Example>

- (1) Stop the external MCKI, BICK and LRCK clocks.

■ Power Down

Power supply current can not be shut down by stopping clocks and setting PMVCM bit = “0”. Power supply current can be shut down (typ. 1μA) by stopping clocks and setting the PDN pin = “L”. When the PDN pin = “L”, all registers are initialized.

PACKAGE

Top View

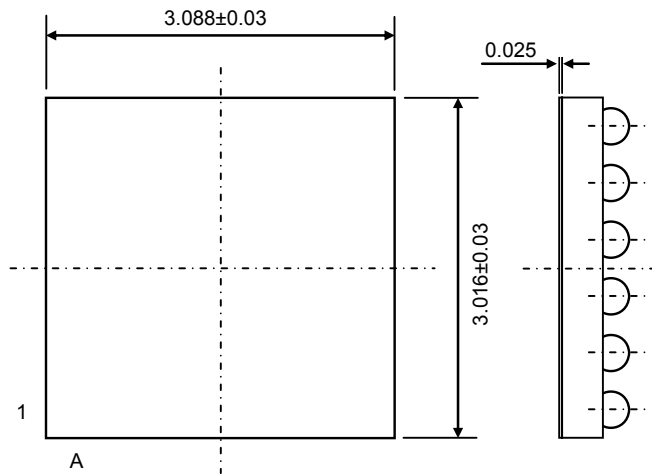

Bottom View

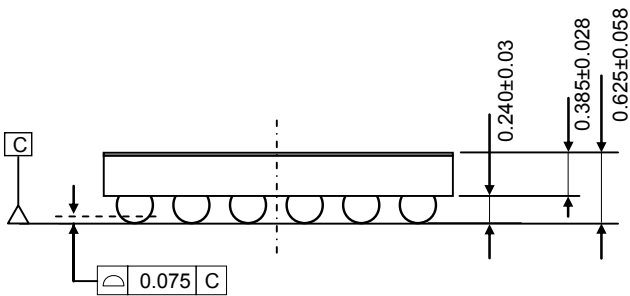
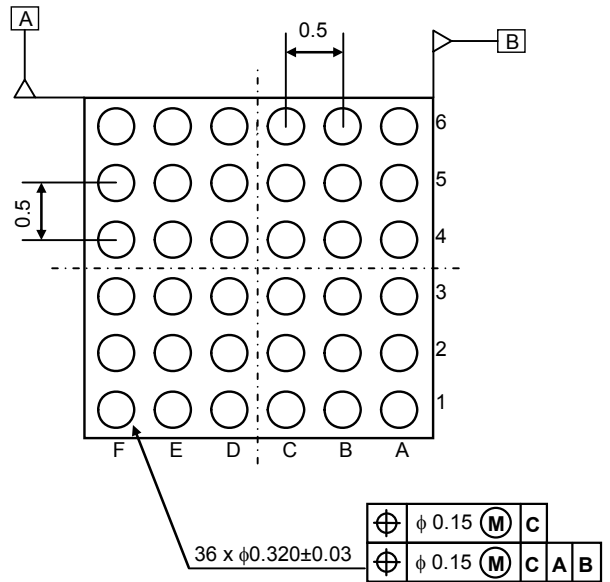

■ Material & Lead finish

Package material: Epoxy resin, Halogen (Br and Cl) free
 Solder ball material: SnAgCu

MARKING

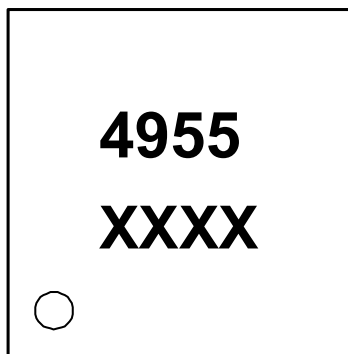

1

XXXX: Date code (4 digit)
Pin #1 indication

REVISION HISTORY

Date (YY/MM/DD)	Revision	Reason	Page	Contents
11/12/28	00	First Edition		

IMPORTANT NOTICE

- These products and their specifications are subject to change without notice.
When you consider any use or application of these products, please make inquiries the sales office of Asahi Kasei Microdevices Corporation (AKM) or authorized distributors as to current status of the products.
- Descriptions of external circuits, application circuits, software and other related information contained in this document are provided only to illustrate the operation and application examples of the semiconductor products. You are fully responsible for the incorporation of these external circuits, application circuits, software and other related information in the design of your equipments. AKM assumes no responsibility for any losses incurred by you or third parties arising from the use of these information herein. AKM assumes no liability for infringement of any patent, intellectual property, or other rights in the application or use of such information contained herein.
- Any export of these products, or devices or systems containing them, may require an export license or other official approval under the law and regulations of the country of export pertaining to customs and tariffs, currency exchange, or strategic materials.
- AKM products are neither intended nor authorized for use as critical components^{Note1)} in any safety, life support, or other hazard related device or system^{Note2)}, and AKM assumes no responsibility for such use, except for the use approved with the express written consent by Representative Director of AKM. As used here:
 - Note1) A critical component is one whose failure to function or perform may reasonably be expected to result, whether directly or indirectly, in the loss of the safety or effectiveness of the device or system containing it, and which must therefore meet very high standards of performance and reliability.
 - Note2) A hazard related device or system is one designed or intended for life support or maintenance of safety or for applications in medicine, aerospace, nuclear energy, or other fields, in which its failure to function or perform may reasonably be expected to result in loss of life or in significant injury or damage to person or property.
- It is the responsibility of the buyer or distributor of AKM products, who distributes, disposes of, or otherwise places the product with a third party, to notify such third party in advance of the above content and conditions, and the buyer or distributor agrees to assume any and all responsibility and liability for and hold AKM harmless from any and all claims arising from the use of said product in the absence of such notification.