

DESCRIPTION

The Accutek AK532512W high density memory module is a CMOS dynamic RAM organized in 512K x 32 bit words. The module consists of sixteen standard 256K x 4 DRAMs in plastic SOJ packages. The assembly has eight drams mounted on each side of a printed circuit board in a 72 pad leadless SIM configuration.

This configuration allows socket-mounting of large quantities of memory in applications where high density and ease of inserting additional memory are important.

The operation of the AK532512W is identical to sixteen 256K x 4 Drams. There are four CAS lines and four RAS lines. On each bank of 256K x 32, independent byte control is accomplished by the four CAS lines. Each separate CAS line controls four 256K x 4 Drams. Two banks of 32 bits are controlled by the two pairs of RAS lines. A sixteen bit data path can be produced by connecting DQ₁ to DQ₁₇, DQ₂ to DQ₁₈ and alternately strobing RAS₀ with RAS₁ and RAS₂ with RAS₃.

FEATURES

- 524,288 x 32 bit organization
- 72 pin Single In-Line Module
- Multiple $\overline{\text{CAS}}$ and $\overline{\text{RAS}}$ lines allow x16 or x32 bit widths
- $\overline{\text{CAS}}$ -before- $\overline{\text{RAS}}$ Refresh, $\overline{\text{RAS}}$ -only Refresh or Hidden refresh
- Operating free air temperature 0°C to 70°C
- Single 5 Volt Power Supply
- 512 Refresh Cycles, 8mSEC
- Available in Fast Page Mode and EDO

PIN NOMENCLATURE

A ₀ - A ₈	Address Inputs
DQ ₁ - DQ ₃₂	Data In/Data Out
$\overline{\text{CAS}}_0$ - $\overline{\text{CAS}}_3$	Column Address Strobe
$\overline{\text{RAS}}_0$ - $\overline{\text{RAS}}_3$	Row Address Strobe
$\overline{\text{WE}}$	Write Enable
PD ₁ - PD ₄	Presence Detect
V _{cc}	5v Supply
V _{ss}	Ground
NC	No Connect

MODULE OPTIONS

Leadless SIM: AK532512W

Leaded ZIP: AK532512Z

PIN ASSIGNMENT

PIN #	SYMBOL	PIN #	SYMBOL	PIN #	SYMBOL	PIN #	SYMBOL
1	V _{ss}	19	NC	37	NC	55	DQ12
2	D1	20	DQ5	38	NC	56	DQ28
3	DQ17	21	DQ21	39	V _{ss}	57	DQ13
4	DQ2	22	DQ6	40	$\overline{\text{CAS}}_0$	58	DQ29
5	DQ18	23	DQ22	41	$\overline{\text{CAS}}_2$	59	V _{cc}
6	DQ3	24	DQ7	42	$\overline{\text{CAS}}_3$	60	DQ30
7	DQ19	25	DQ23	43	$\overline{\text{CAS}}_1$	61	DQ14
8	DQ4	26	DQ8	44	$\overline{\text{RAS}}_0$	62	DQ31
9	DQ20	27	DQ24	45	$\overline{\text{RAS}}_1$	63	DQ15
10	V _{cc}	28	A7	46	NC	64	DQ32
11	NC	29	NC	47	$\overline{\text{WE}}$	65	DQ16
12	A0	30	V _{cc}	48	NC	66	NC
13	A1	31	A8	49	DQ9	67	PD1
14	A2	32	NC	50	DQ25	68	PD2
15	A3	33	$\overline{\text{RAS}}_3$	51	DQ10	69	PD3
16	A4	34	$\overline{\text{RAS}}_2$	52	DQ26	70	PD4
17	A5	35	NC	53	DQ11	71	NC
18	A6	36	NC	54	DQ27	72	V _{ss}

Presence Detect -

	-60	-70	-80
PD1	NC	NC	NC
PD2	V _{ss}	V _{ss}	V _{ss}
PD3	NC	V _{ss}	NC
PD4	NC	NC	V _{ss}

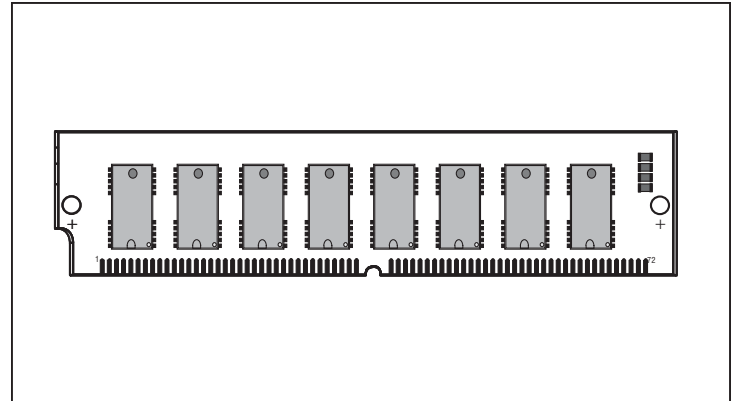

- Power
 - 4.00 Watt Max Active (60nS)
 - 3.56 Watt Max Active (70 nS)
 - 3.124 Watt Max Active (80 nS)
 - 88 mW Max Standby
- Available in leadless SIM or leaded Zip versions
- Downward compatible with AK532256
- Upward compatible with AK5321024, AK5322048, AK5324096 and AK5328192

ADDITIONAL OPTIONS AVAILABLE

- 256K x 32 version, AK532256
- 1 Meg x 32 version, AK5321024
- 2 Meg x 32 version, AK5322048
- 4 Meg x 32 version, AK5324096
- 8 Meg x 32 version, AK5328192

FUNCTIONAL DIAGRAM

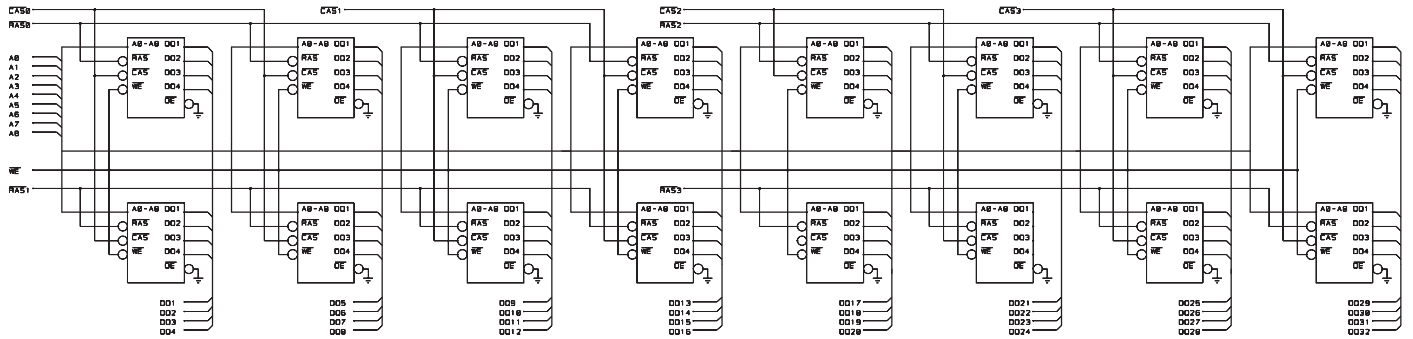

MECHANICAL DIMENSIONS

