

DC Motor Controller

AK9824/AK24/K24

Advise:

Make sure there is correct number of components in your package. Use 30W iron, 60% solder. Take extra caution against overheating during soldering process. Transistors and ICs can be easily damaged by high temperature so do not leave the iron on the board for too long. Too many or too little solders may cause a defected circuit. Please weld the IC socket first then plug in the IC chip.

Instruction:

After the assembling job completed, push the “switch” to “ON” position, the LED light will be on which means the power is on now, adjust VR (Variable Resistors) from Slow → Fast, the motor speed will change from slow to fast gradually. Adjust VR from Fast → Slow, the motor speed will change from fast to slow gradually, maximum speed of the motor included is 5200 RPM, user can apply it on remote control car or remote control boat.....etc.

Circuit Explanation:

This circuit uses PWM (Pulse Width Modulation) to control the motor speed. Wider the positive pulse faster the motor, wider the negative pulse slower the motor. JRC2904 is acting as comparator in this circuit. When motor is running we pull out a signal from motor, after RC processing we feed it back to JRC2904 for comparison. Adjust VR so input voltage increases, output voltage pulse will be modulated and motor speed change from Fast to Slow (If voltage is higher than 1.2V then motor will stop). Adjust VR so input voltage decreases, output voltage pulse will be modulated and motor speed change from Slow to Fast (When voltage is lower than 1.2V then motor will start, motor is fastest at 0V)

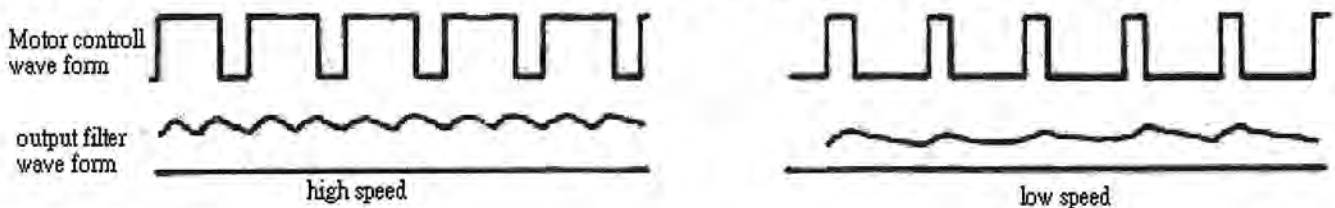

Parts list							
Serial No.	Component	Qty.	Remark	Serial No.	Component	Qty.	Remark
U1	IC 2904	1	Mind IC pin	VR1	10K	1	Variable Resistor
Q1	FET 2N60	1	Mind pin direction	C1	2.2 μ F	1	Electrolytic Capacitors
R1	33K	1	Or,Or,Or,Go	C2,C3,C4	0.1 μ F	3	104p
R2	150K	1	Br,Gn,Ye,Go	D1,D2,D3,D4	1N4148	4	
R3	10K	1	Br,Bk,Or,Go	M1	DC motor	1	
R4	2M	1	Re,Bk,Gn,Go	LED1	LED	1	Long-pin positive
R5	330 Ω	1	Or,Or,Br,Go	S1	SW 6P	1	
R6,R8	100K	2	Br,Bk,Ye,Go	B1	6V battery holder	1	
R7	6.8K	1	Bl,Gr,Re,Go	U1	8PIN IC socket	1	
R9	1K	1	Br,Bk,Re,Go	K24	PCB	1	

Code: Black:Bk, Brown:Br, Red:Re, Orange:Or, Yellow:Ye, Green:Gn, Blue:Bl, Purple:Pu, Grey:Gr, Gold:Go

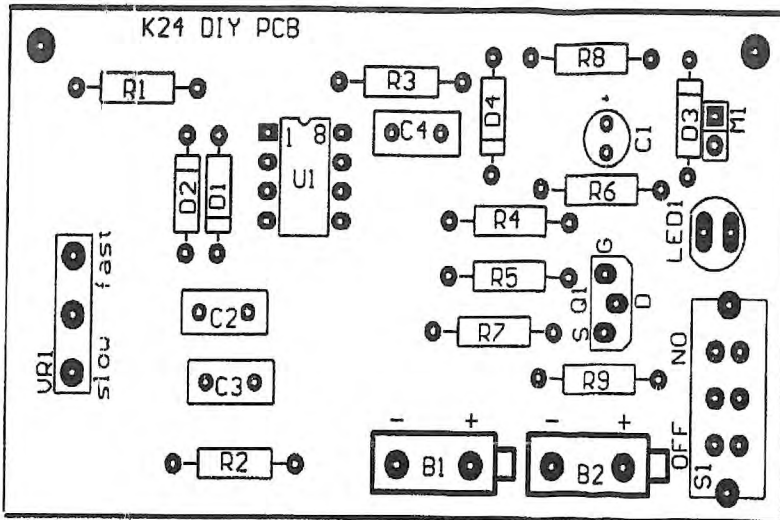

FET 2N60

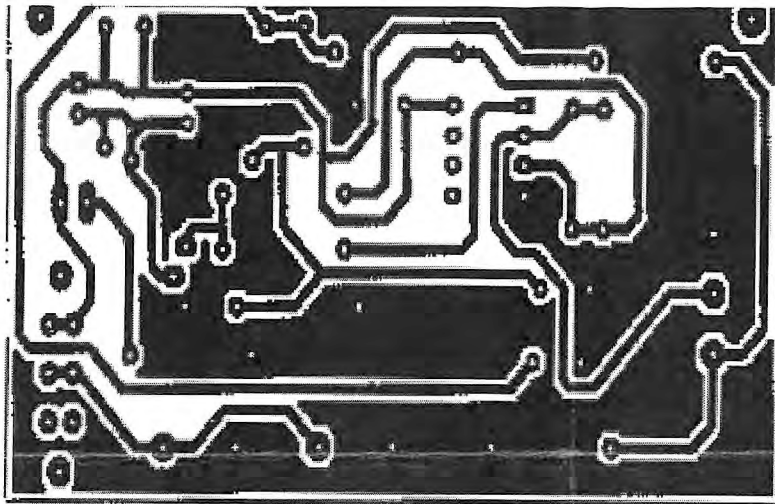
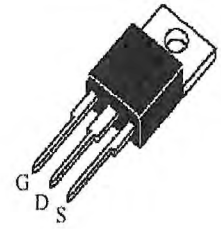

LED

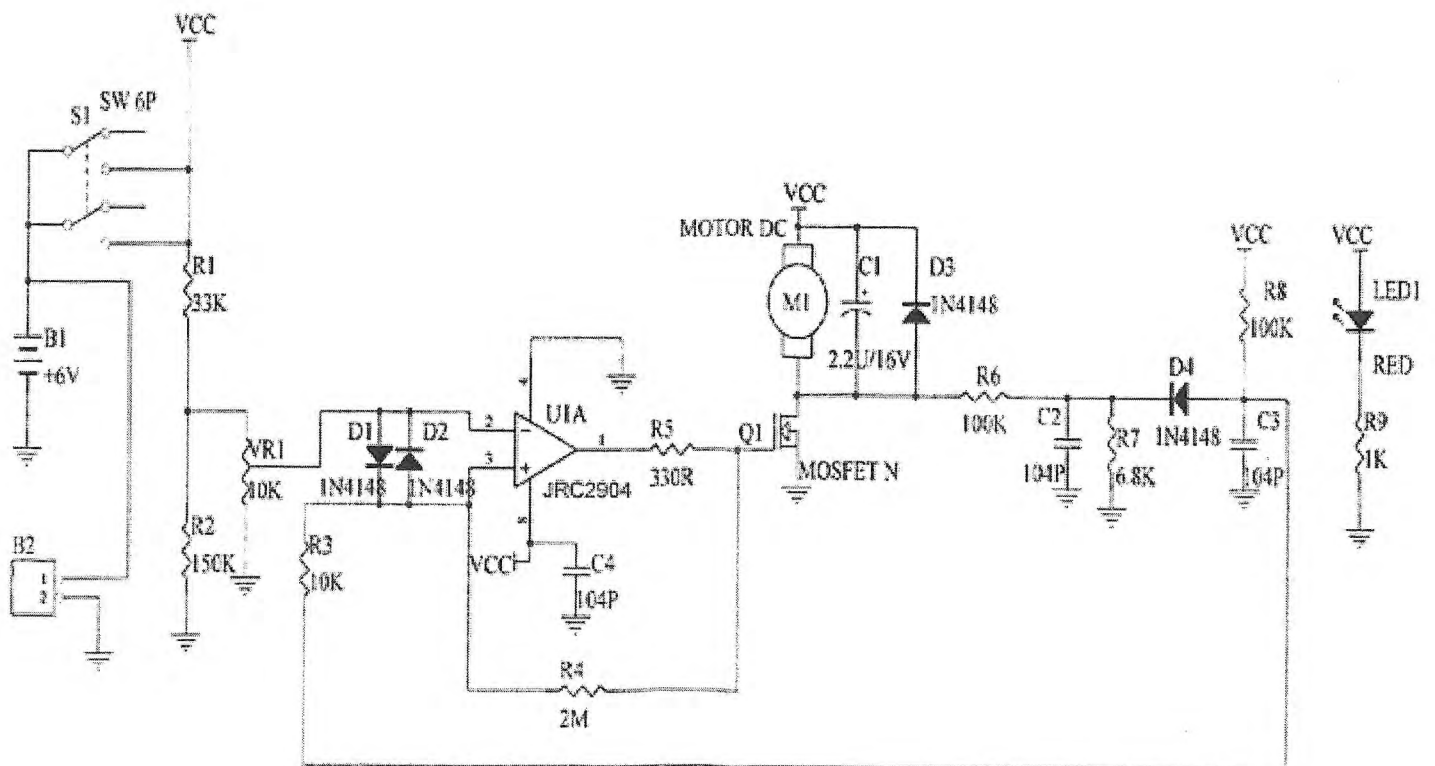
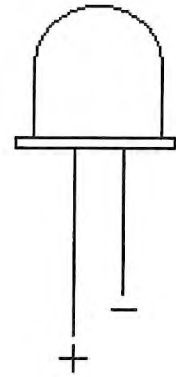

速控直流馬達控制器

感謝您購買睿意科技『小小零件大大學問』套件。

關於套件教育，我們強調的是動手能力的培養，如何由一個構思開始，從進行分析、設計、硬體製作、測試、評估等有系統的學習，使學生在就業前能儘可能的吸收專業知識及培養思考能力，俾使每位學生在未來工業界均能學以致用廣受歡迎。因此每一個套件的主題均是經過慎選與反覆驗證而來的。

建議:

請使用 30W 烙鐵，60%焊錫。套件裝配之前，務必清點零件數量，確認無誤後再開始裝配工作。焊接過程中，應防止過熱。電晶體及 IC 都很怕高溫，焊接時烙鐵勿擱置過久。焊錫的使用量過多過少，都會造成線路上的不良。記得請先焊 IC 腳座再插入 IC。

使用說明:

本套件製作完畢使用時，只要把指撥開關推至 ON，LED 燈亮表示電源開啟中，再調整 VR（可變電阻）從 SLOW→FAST，馬達轉速則會由慢轉漸漸變快轉。VR 從 FAST→SLOW，馬達則會由快轉漸漸變慢。本套件的馬達最快可達到 5200 rpm 轉速，使用者可將本套件應用在遙控車或遙控船上。（使用零件請參考零件表）。

電路說明:

本電路使用 PWM（脈波寬調變）的方式，控制馬達快慢（如圖一的波形）。也就是說當波頂寬度越寬，馬達轉速就越快；反之，波谷寬度越寬，馬達轉速就會越慢。馬達運轉時，電路中以 JRC2904 的 IC 作為比較器，當 MOTOR 開始動作時，將 MOTOR 訊號拉出，經由電阻電容處理後再拉回 JRC2904 做比較。若將 VR 慢慢旋轉使輸入電壓上升，輸出電壓的脈波就會慢慢調變，由高速變低速（高於 1.2V 時，MOTOR 即停止轉動）；VR 慢慢旋轉使輸入電壓下降，輸出電壓脈波則慢慢調變，由低速變高速（低於 1.2V 時，MOTOR 就會開始轉動，調至 0V 時，MOTOR 轉速最快）。

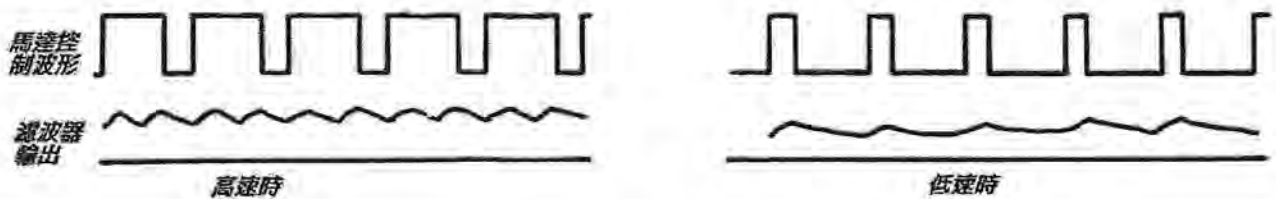

零件表

零件編號	使用零件規格	數量	備註	零件編號	使用零件規格	數量	備註
U1	IC 2904	1	注意 IC 腳位	VR1	10K	1	可調電阻
Q1	FET 2N60	1	注意腳位	C1	2.2 μ F	1	電解電容
R1	33K	1	橙橙橙金	C2,C3,C4	0.1 μ F	3	104P
R2	150K	1	棕綠黃金	D1,D2,D3,D4	1N4148	4	
R3	10K	1	棕黑橙金	M1	直流馬達	1	
R4	2M	1	紅黑綠金	LED1	LED	1	長腳為正
R5	330 Ω	1	橙橙棕金	S1	SW 6P	1	
R6, R8	100K	2	棕黑黃金	B1	6V 電池盒	1	
R7	6.8K	1	藍灰紅金	U1	8PIN IC 腳座	1	
R9	1K	1	棕黑紅金	K24	PCB	1	

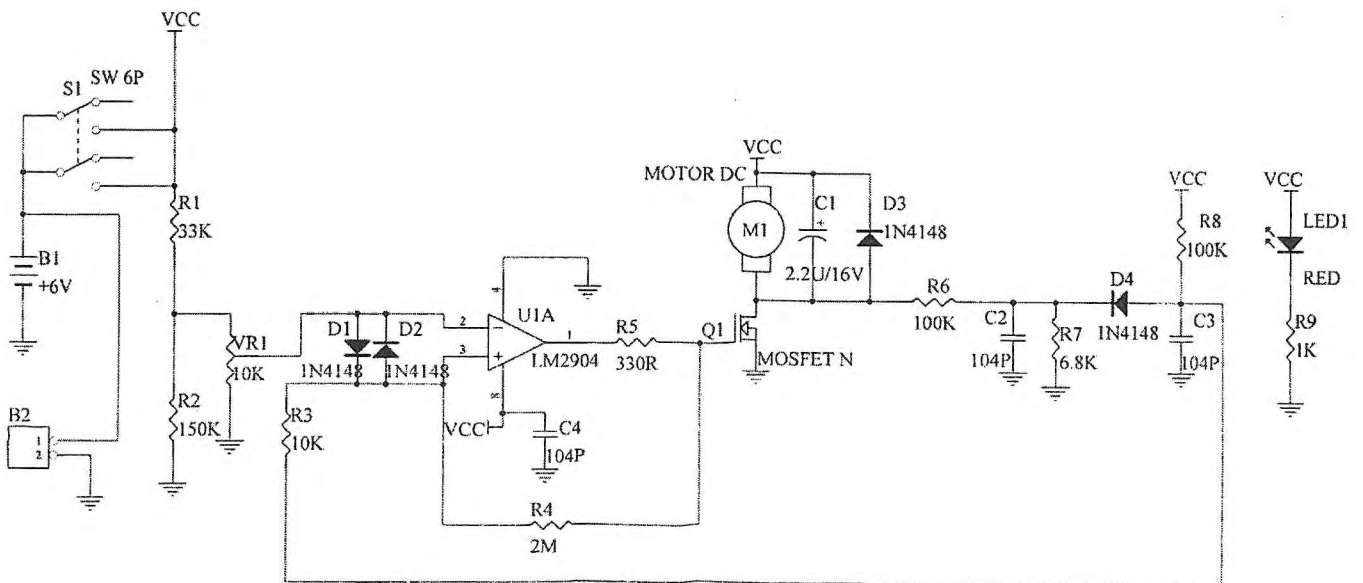
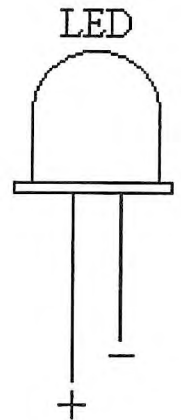
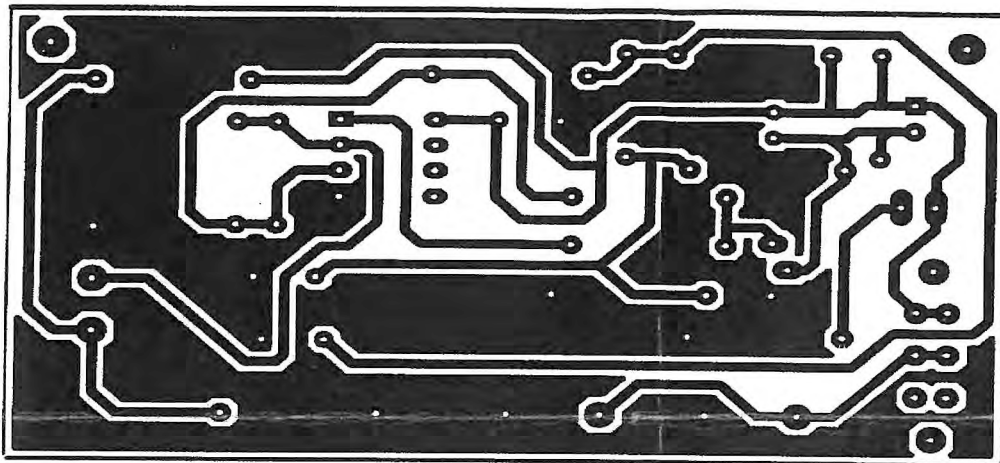
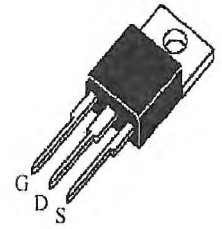
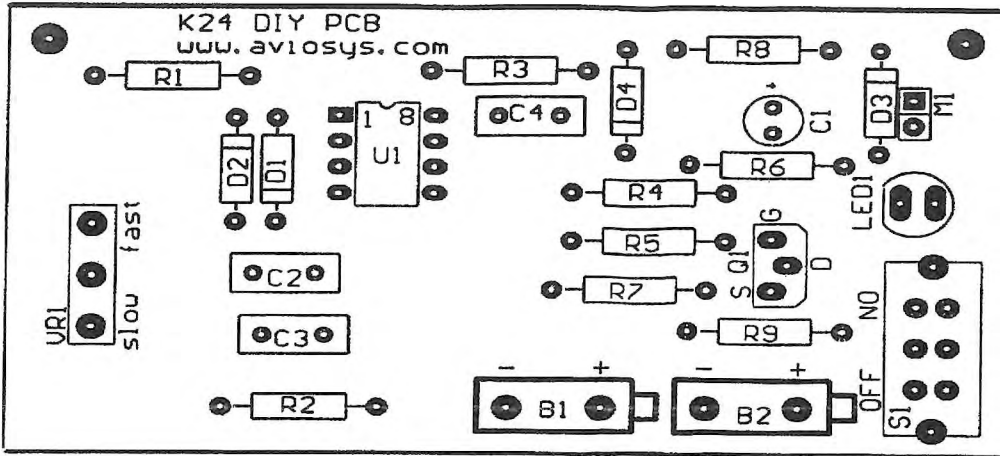

睿意科技股份有限公司 Tel: (02) 2959-2092
 網址: <http://www.aviosys.com.tw> E-mail: service@aviosys.com