

# AKU240 Family

## Top port, Digital Silicon MEMS Microphones

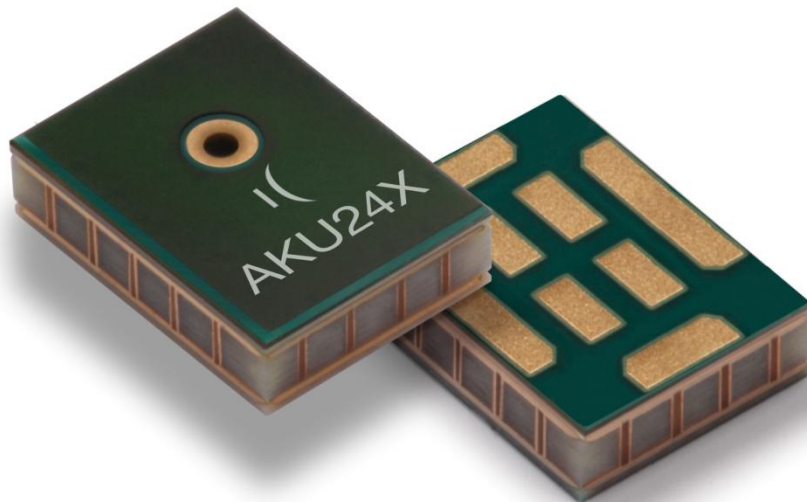

### Data Sheet

Part number(s)	AKU240, AKU241, AKU242
Package type	8-pin LGA top port
Data sheet revision	1.01
Release date	23 December 2014
Document number	DS45-1.01 AKU240 Family Data Sheet
Notes	Specifications are subject to change without notice. Product photos and pictures are for illustration purposes only and may differ from the real product's appearance.

# AKU240 Family

## Digital, HD Voice Silicon MEMS Microphones

### General Description

AKU240 family consists of HD Voice quality, top port, digital output silicon MEMS IC microphones. They are microphones consisting of a MEMS acoustic sensor, and an integrated circuit (IC) with a pre-amplifier, analog-to-digital converter, charge pump and supporting circuitry in a small 4.0 x 3.0 x 1.0 mm<sup>3</sup> package.

The robust digital output stream from the

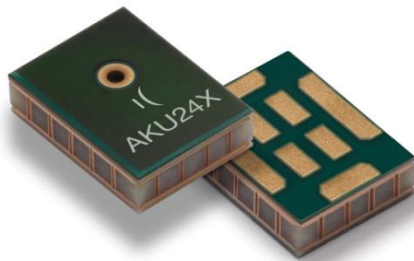

AKU240 family is virtually immune to all forms of Radio Frequency Interference (RFI) and Electromagnetic Interference (EMI), allowing designers the flexibility to integrate the component anywhere on the platform and obtain consistent SNR regardless of proximity to displays, Wi-Fi antennae, or other sources of interference that would degrade the signal of conventional analog microphones.

The devices in this family provide a pulse density modulated (PDM), single-bit digital stream designed to enable the multiplexing of stereo microphone data onto a single wire. With a user selectable L/R channel option, it is ideal for use in multiple microphone applications.

### Key Features

- Digital PDM output
- Omni-directional audio sensor
- Excellent acoustic performance: 63dB SNR
- Sensitivity: -26dBFS
- Tightly controlled sensitivity tolerances:
  - AKU240: ± 2dB
  - AKU241: ± 1dB
  - AKU242: ± 1.5dB
- Compatible with Microsoft® Windows®, LYNC® & Skype® logo certifications, Intel® Ultrabook™ and Google® Chromebook™ requirements for digital microphones
- Robust digital-output & Faraday-cage constructed package immune to RF/EM interference
- Matched microphones in frequency and phase response for array applications
- Output supports dual-microphone, single-wire multiplexing
- Industry standard microphone interface compatible with multiple codecs
- Low current power-down mode
- Lead-free surface-mountable and RoHS2 compliant
- Halogen-free compliance, IEC61249-2-21
- Thin profile, SMT packaging
- Industry std. package: 4.00x3.00x1.00mm<sup>3</sup>

### Typical Applications

- Ultrabooks
- Mobile phones
- Media tablets
- eReaders
- Microphone arrays
- Webcams and camera modules

	<b>AKU240 Family</b> Digital Silicon MEMS Microphones	Data Sheet
---	--	------------

## Index of Contents

<b>1. ABSOLUTE MAXIMUM RATINGS.....</b>	<b>4</b>
<b>2. STANDARD OPERATING CONDITIONS.....</b>	<b>4</b>
<b>3. ELECTRICAL AND ELECTRO-ACOUSTIC SPECIFICATIONS.....</b>	<b>4</b>
3.1 Timing Characteristics	
3.2 Digital Logic Characteristics	
3.3 Sleep Mode, and Active Mode	
3.4 Radio Frequency Interference (RFI) Immunity	
<b>4. DEVICE CHARACTERISTICS .....</b>	<b>7-8</b>
4.1 Typical Frequency Response	
4.2 $I_{DD}$ vs. $V_{DD}$	
4.3 Sensitivity vs. $V_{DD}$	
4.4 $I_{DD}$ vs. Clock Frequency	
4.5 Sensitivity vs. Temperature	
4.6 PSR vs. Frequency	
<b>6. PIN-OUT AND CONNECTION DIAGRAMS.....</b>	<b>9</b>
6.1 Pin Out	
6.2 Schematic	
<b>7. MANUFACTURING NOTES.....</b>	<b>10-12</b>
7.1 Solder Reflow	
7.2 Part Handling	
7.3 PCB Land Pattern & Stencil Pattern	
<b>8. RELIABILITY SPECIFICATIONS.....</b>	<b>13</b>
<b>9. PART MARKING INFORMATION.....</b>	<b>13</b>
<b>10. PACKAGING INFORMATION.....</b>	<b>14</b>
<b>11. ORDERING INFORMATION .....</b>	<b>15</b>
<b>12. DOCUMENT REVISIONS.....</b>	<b>15</b>

	<b>AKU240 Family</b> Digital Silicon MEMS Microphones	Data Sheet
---	--	------------

### 1. ABSOLUTE MAXIMUM RATINGS

Supply Voltage, $V_{DD}$ to GND	5.5V
ESD Tolerance	
Human Body Model	2000V
Machine Model	200V
Storage Temperature Range	-40°C to 105°C

### 2. STANDARD OPERATING CONDITIONS

Operating Temperature Range	-40°C to 85°C
Supply Voltage ( $V_{DD}$ )	1.62V to 3.6V
Clock Frequency	1.00MHz to 3.25MHz

### 3. ELECTRICAL AND ELECTRO-ACOUSTIC SPECIFICATIONS

Unless otherwise noted, test conditions are:  
 $V_{DD} = 1.8V$     $T_a = 25^\circ C$     $RH = 50\%$     $CLK = 2.4MHz$

Parameter		Test Conditions	Min.	Typ.	Max.	Unit
Directivity			Omni-directional			
Signal to Noise Ratio (SNR)		$f_{in} = 1kHz$ , A-weighted, 20Hz-10kHz		63		dB
Low Frequency Corner <sup>1</sup>		-3dB from 1kHz sensitivity value		50	100	Hz
High Frequency Corner		+3dB from 1kHz sensitivity value		11		kHz
Sensitivity <sup>1</sup>	AKU240	1kHz, 94dB SPL, full-scale = 100% 1's density at PDM output of microphone	-28	-26	-24	dBFS
	AKU241		-27	-26	-25	
	AKU242		-27.5	-26	-24.5	
Total Harmonic Distortion <sup>1</sup> (THD)		@ 100dB SPL, $f_{in} = 1kHz$			1	%
		@ 110dB SPL, $f_{in} = 1kHz$			5	
Acoustic Overload Point (AOP)		< 10% THD, $f_{in} = 1kHz$		116		dB SPL
Power Supply Rejection (PSR)		Signal on $V_{DD} = 217Hz$ , 100mV <sub>pp</sub>		-73		dBFS
Part-to-part phase matching from nominal		$f_{in} = 1kHz$			$\pm 10$	°
Current Consumption <sup>1</sup> (with no load)	AKU240/242	Clock on (CLK = 2.8MHz)		800	930	$\mu A$
	AKU241			865	1020	$\mu A$
		Clock off		5	7	$\mu A$
Power-up initialization		Data invalid time from clock on			28	ms
Polarity		Increasing sound pressure	Increasing 1's density			

Note 1: Max. value of parameter 100% tested

### 3.1 Timing Characteristics

(Typical performance with load capacitance <20pF and a clock frequency of 2.4MHz)

	Typical Mode	Data Valid	Data Sampled	L/R SELECT Connected to
<b>DATA<sub>L</sub></b>	Left	Falling clock	Rising clock	GND
<b>DATA<sub>R</sub></b>	Right	Rising clock	Falling clock	V <sub>DD</sub>

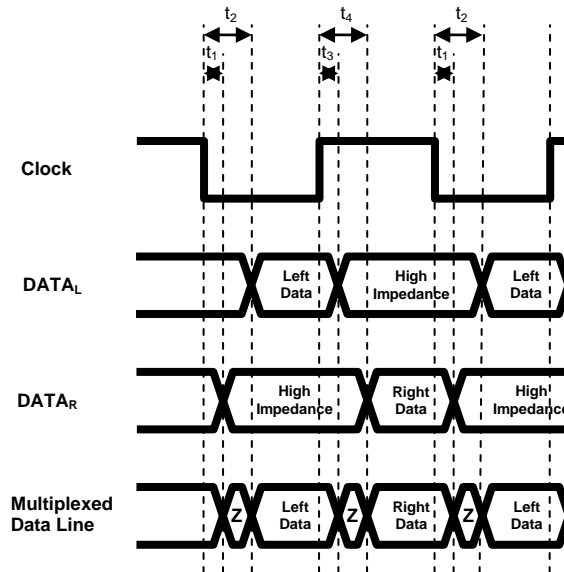

Output	Parameter	Typical Value	Description
<b>DATA<sub>R</sub></b>	<b>t<sub>1</sub></b>	6ns	Time from falling edge of clock until data becomes high impedance
<b>DATA<sub>L</sub></b>	<b>t<sub>2</sub></b>	61ns	Time from falling edge of clock until data becomes valid
<b>DATA<sub>L</sub></b>	<b>t<sub>3</sub></b>	6ns	Time from rising edge of clock until data becomes high impedance
<b>DATA<sub>R</sub></b>	<b>t<sub>4</sub></b>	53ns	Time from rising edge of clock until data becomes valid

### 3.2 Digital Logic Characteristics

(Typical performance with load capacitance <20pF and a clock frequency of 2.4MHz)

Symbol	Parameter	Min	Max	Units
$V_{IL\ MAX}$	Maximum level considered a logic 0		$0.4 \cdot V_{DD}$	V
$V_{IH\ MIN}$	Minimum level considered a logic 1	$0.5 \cdot V_{DD}$		V
$V_{OL\ MAX}$	Maximum level a driven output logic 0 can be		$0.05 \cdot V_{DD}$	V
$V_{OH\ MIN}$	Minimum level a driven output logic 1 can be	$0.95 \cdot V_{DD}$		V

### 3.3 Sleep Mode, and Active Mode

The AKU24X enters Sleep Mode within 5µS of the clock signal becoming inactive (i.e. clock frequency = 0Hz).

In Sleep Mode the microphone PDM Data output pin is in high impedance state.

The microphone returns from Sleep Mode to Active Mode 65,536 cycles after the clock becomes active (i.e. clock frequency  $\geq 1.0$ MHz). With a 3.072MHz clock, the microphone start-up time is 21.4ms; for a 2.4MHz clock the microphone start-up time is 27.4ms.

### 3.4 Radio Frequency Interference (RFI) Immunity

The AKU240 family is virtually immune to all forms of Radio Frequency Interference (RFI) and Electromagnetic Interference (EMI). Select devices in the family have additional built-in RF filter(s), as shown in the microphone block diagram below.

Please refer to the ordering information table in section 11, for available device options.

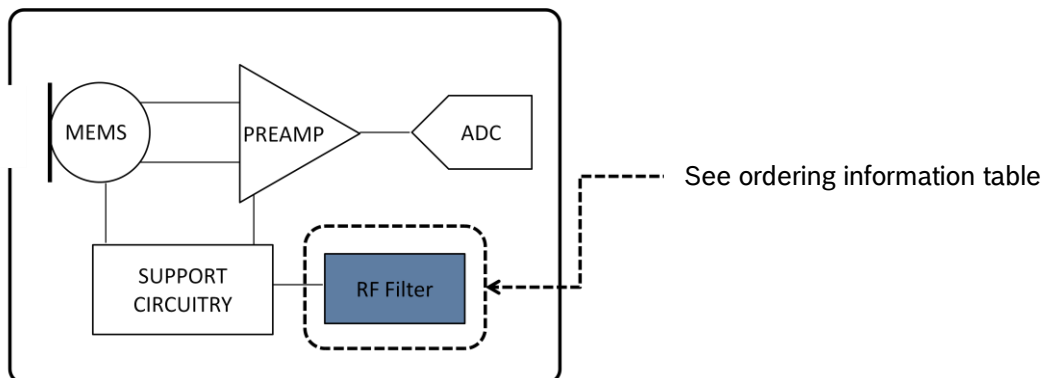

## 4. DEVICE CHARACTERISTICS

### 4.1 Frequency Response

(Measured frequency response normalized to 1kHz)

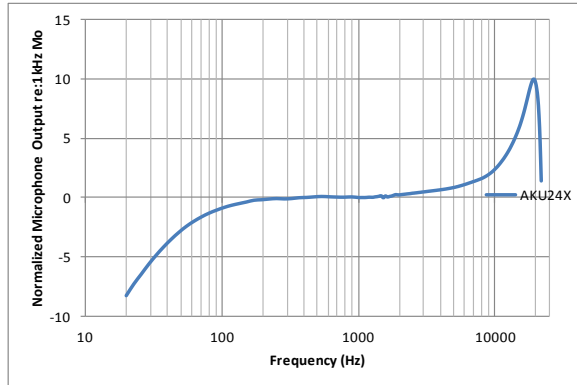

### 4.2 I<sub>DD</sub> vs. V<sub>DD</sub>

(Measured current consumption relative to supply voltage)

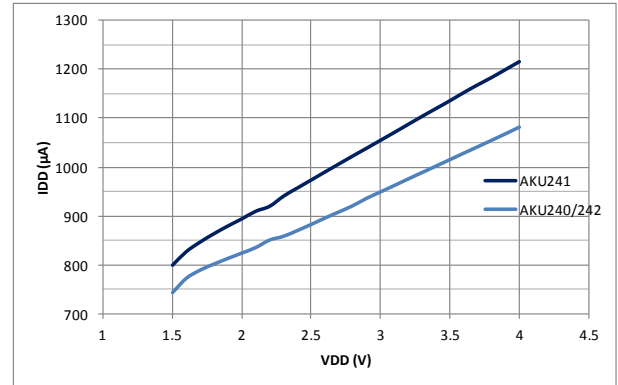

### 4.3 Sensitivity vs. V<sub>DD</sub>

(Measured sensitivity changes relative to supply voltage)

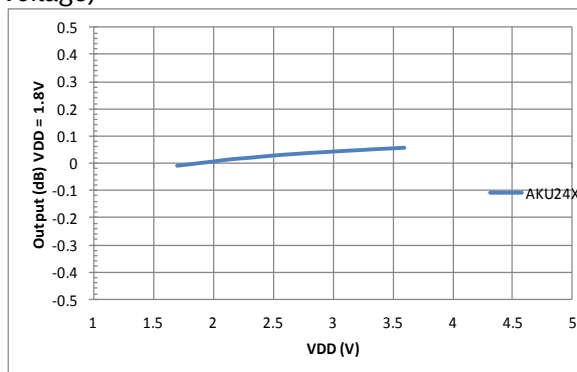

### 4.4 I<sub>DD</sub> vs. Clock Frequency

(Measured current consumption relative to clock frequency)

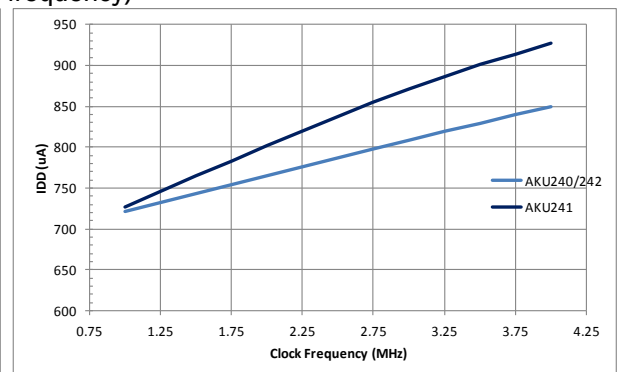

### 4.5 Sensitivity vs. Temperature

(Typical sensitivity changes relative to temperature)

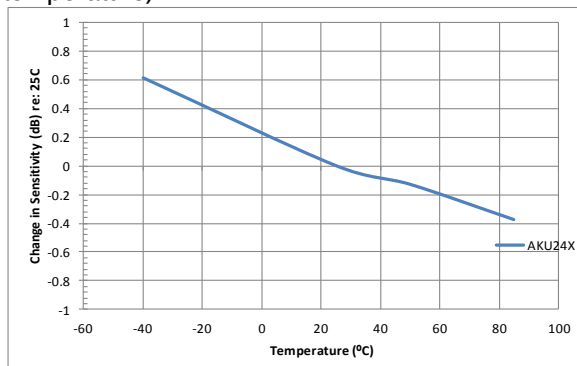

### 4.6 PSR vs. Frequency

(Typical PSR relative to frequency)

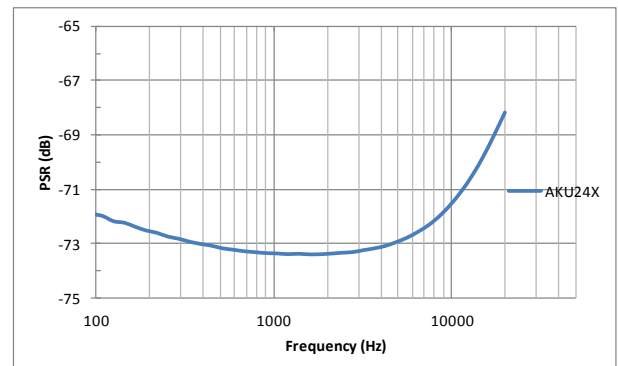

**5. MECHANICAL SPECIFICATIONS**

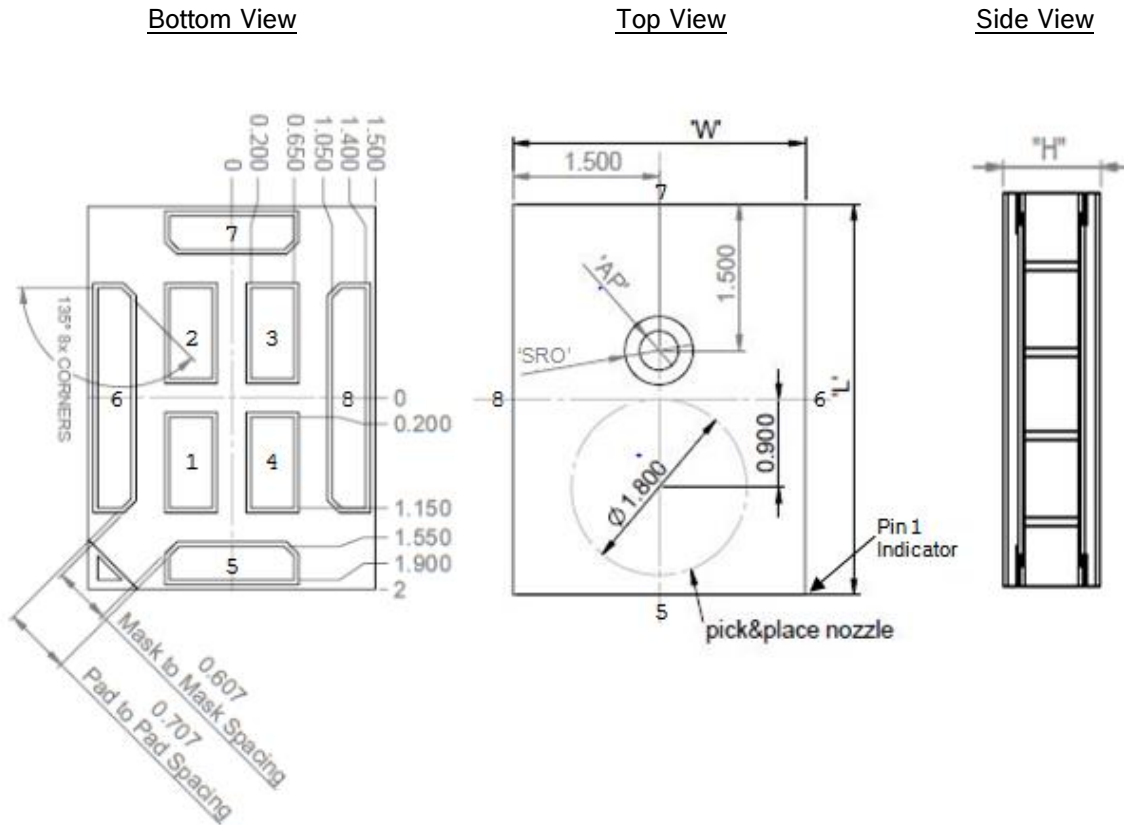

Item	Dimension	Tolerance	Units
Length (L)	4.00	± 0.10	mm
Width (W)	3.00	± 0.10	mm
Height (H)	1.00	± 0.10	mm
Acoustic Port (AP)	0.400	± 0.10	mm
Solder Mask (SRO)	0.700	± 0.05	mm
Planarity	Top/Bottom	± 0.10	mm
All dimensions in mm Tolerance ± 0.05mm unless otherwise specified			



## 6. PIN-OUT AND CONNECTION DIAGRAMS

### 6.1 Pin-Out

(As viewed from **bottom** of package)

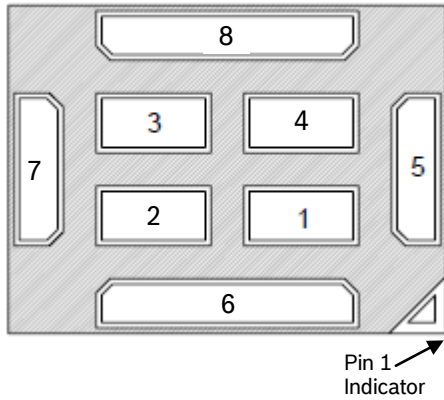

Pin	Name	Function
1	V <sub>DD</sub>	Power
2	L/R*	Left / Right Select
3	CLK	Clock
4	DATA	PDM Data output
5, 6, 7, 8	GND	Ground

\*Must be electrically connected to either ground or V<sub>DD</sub>.

### 6.2 Typical Application Schematic

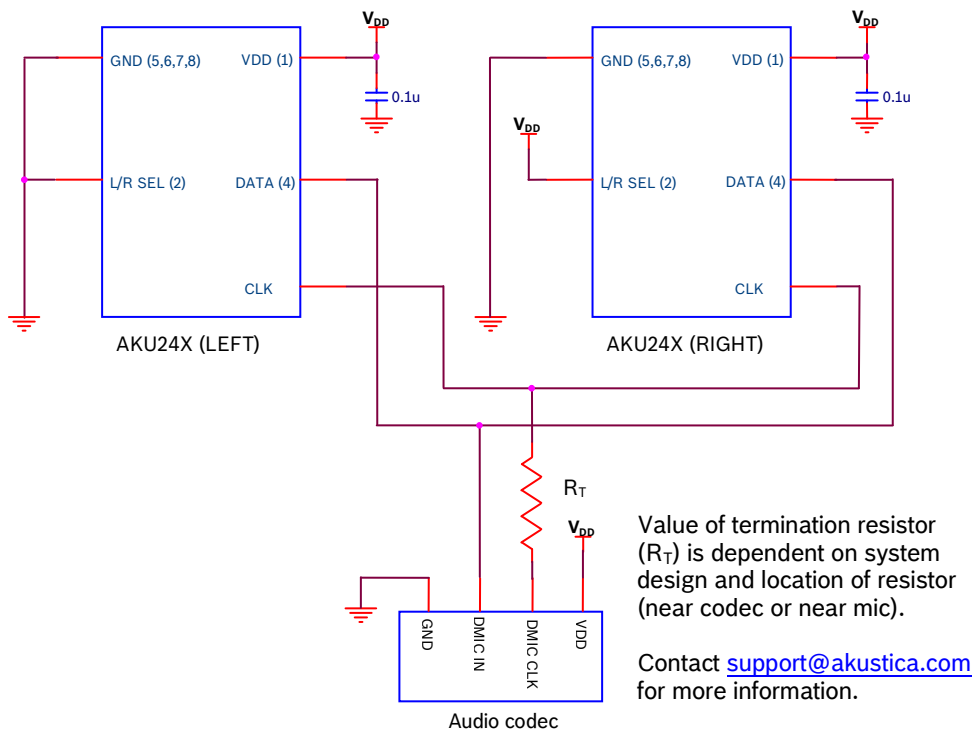

## 7. MANUFACTURING NOTES

### 7.1 Solder Reflow

Typical solder reflow profile

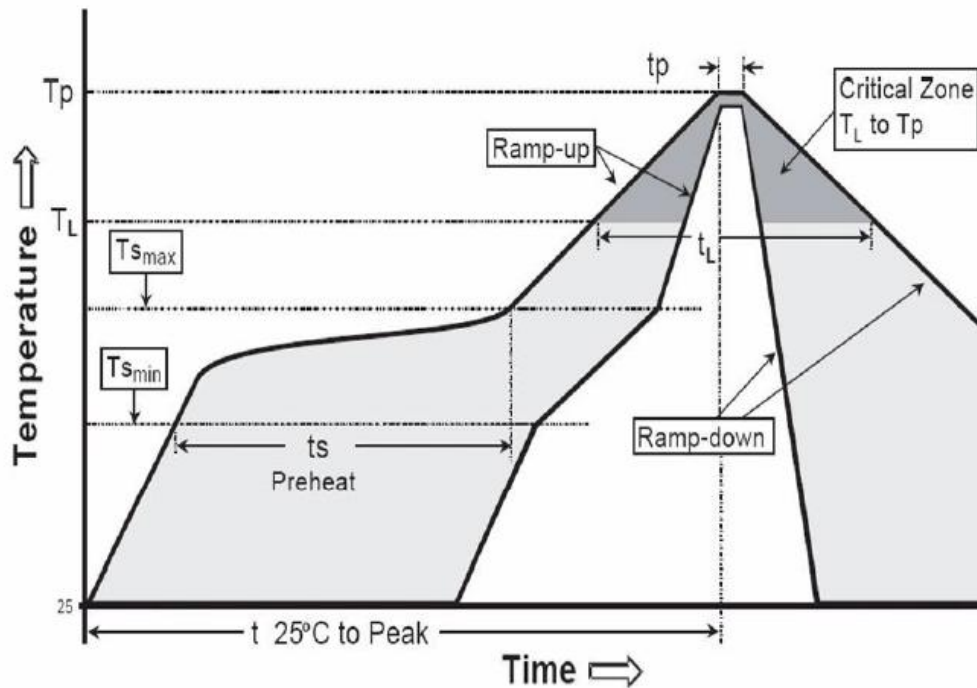

IPC-0206-5-1

Average ramp-up rate	max. 3°C/s
Time $t_s$ between $T_{s_{min}}$ (150°C) and $T_{s_{max}}$ (200°C)	60s – 120s
Time $t_L$ above liquidous temperature $T_L$ (217°C)	60s – 90s
Peak temperature $T_p$	max. 260°C
Time $t_p$ at $T_p$	max. 20s
Average ramp-down rate	max. 6°C/s

Note: It is recommended to fine-tune the reflow process to optimize for variations in materials, environment, handling, PCB board size and thickness, etc.

Please refer to AN60-Handling, Soldering, and Mounting Instructions for more detailed information and precautions.

	<b>AKU240 Family</b> Digital Silicon MEMS Microphones	Data Sheet
---	--	------------

## 7.2. Microphone Handling

Although the microphone may not appear damaged immediately due to inappropriate handling, there can be long term effects that affect the lifetime of the component.

Rule of thumb: The microphone is an artificial ear so treat it like your own ear.

- Do not blow air into the acoustic port of the microphone for any reason. Do not subject it to pressurized air
  - e.g. when cleaning the board or other components on the same board
- Do not apply vacuum to acoustic port of the microphone
  - See section 5.0 for pick & place location
- Do not insert liquids
  - If populated circuit boards are washed, the microphone must be protected
- Do not insert dust
  - The production facilities must be clean
  - e.g. if PCB routing/sawing is done close to the microphone after SMT assembly and reflow
- Do not insert any objects
  - If assembly or rework is done manually, care must be taken that the tools cannot enter the microphone sound port
  - It is best to choose tool size so that it does not fit through the sound port of the microphone
- Do not cover the acoustic port with tape when heating during assembly or reflow
- Do not apply extreme mechanical stresses on the microphone, including mechanical shocks above 10kG or compression of the microphone package.
- After a bottom port microphone has been assembled on a circuit board, protect the sound port (now on the other side of the board) from dust, liquids, and other foreign materials as well as any tools and pressurized air.

### ESD Handling Procedures



Follow CMOS handling procedures with Akustica MEMS microphones. Handle the microphone with proper workplace grounding to include wrist straps and ionized airflow over open trays and reels of microphones. Do not hot-swap/hot-plug during testing. Device pins have ESD ratings of 2kV/200V for HBM/MM respectively.

### 7.3 PCB Land Pattern & Stencil Pattern

**PCB Land Pattern Layout**

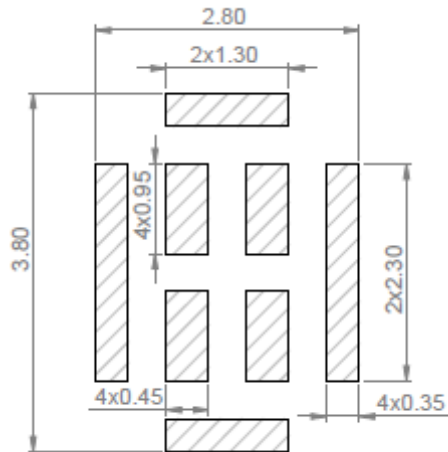

**Suggested Solder Paste Stencil Pattern Layout**

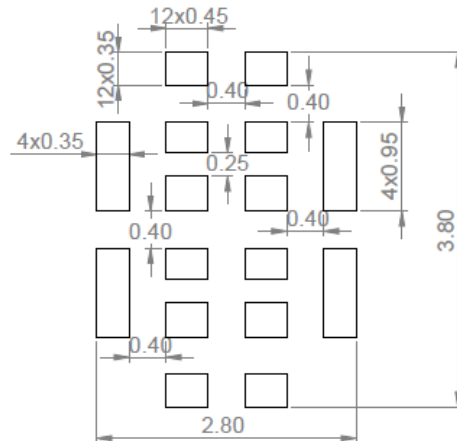

Note: Stencil printer settings will likely require minor optimizations when transferring this stencil pattern to a high volume production printer.

Please refer to AN60-Handling, Soldering, and Mounting Instructions for more detailed information and precautions.

	<b>AKU240 Family</b> Digital Silicon MEMS Microphones	Data Sheet
---	--	------------

## 8. RELIABILITY SPECIFICATIONS

The microphone sensitivity after stress must deviate by no more than 3dB from the initial value.

	Test	Test Condition
1	Cold Temp Operation	Temperature = -40°C, 1000 hours (with bias)
2	Hot Temp Operation	Temperature = 105°C, 1000 hours (with bias)
3	Humidity Operation	Temperature = 85°C, RH = 85%, 1000 hours (with bias)
4	Cold Temp Storage	Temperature = -40°C, 1000 hours (without bias)
5	Hot Temp Storage	Temperature = 105°C, 1000 hours (without bias)
6	Humidity Storage	Temperature = 85°C, RH = 85%, 1000 hours (without bias)
7	Thermal Cycle	100 Cycles, -40°C to +125°C, 15min soaks, <30sec ramps
8	Vibration	Sinusoidal Vibration, 20Hz-2000Hz, 4min sweeps, 16min along each of 3 axis, amplitude 3 limits of 20G and 0.06"
9	Mechanical Shock	10,000G shocks, 5 impacts along each of 6 axes
10	Drop Test	Using 150gm aluminum fixture, 3 drops along each of 6 axes (total 18 drops) from 1.5m height onto concrete drop surface.
11	ESD (HBM)	+/- 2000V, 1 discharge for each polarity, 11 pin combinations, 22 total discharges per microphone
12	ESD (MM)	+/- 200V, 1 discharge for each polarity, 11 pin combinations, 22 total discharges per microphone
13	ESD	+/- 8kV, contact discharge to lid with DUT grounded
14	Moisture Sensitivity Level	24 hour bake at 125°C, followed by 168 hours at 85°C, 85%RH, followed by 3 passes solder reflow (MSL Level 1)

## 9. PART MARKING INFORMATION



Line 1: A24XF (A = Akustica | 24X = Part Num | X = 0, 1, 2 | F = Assembly Facility)  
 Line 2: WWYLL (WW = Work Week | Y = Year | LL = Lot Number Processed During Work Week)

← Pin 1

## 10. PACKAGING INFORMATION

### 10.1 Tape Specification

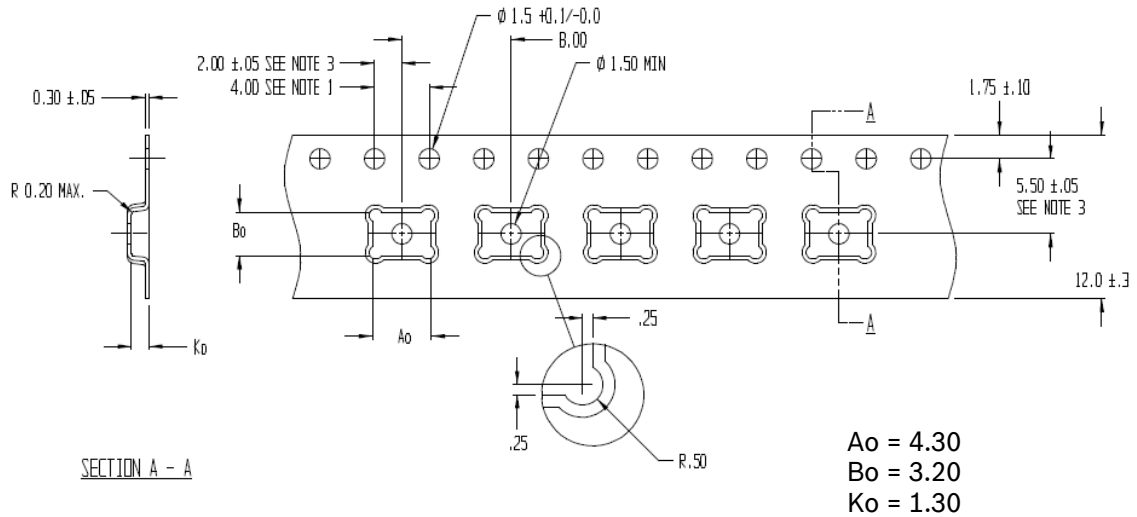

Notes:

1. 10 sprocket hole pitch cumulative tolerance +/- 0.2
2. Camber in compliance with EIA-481
3. Pocket position relative to sprocket hole measured as true position of pocket, not pocket hole

### 10.2 Component Orientation

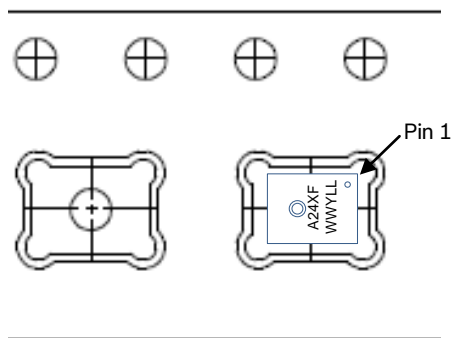

	<b>AKU240 Family</b> Digital Silicon MEMS Microphones	Data Sheet
---	--	------------

## 11. ORDERING INFORMATION

Order Number	Sensitivity Tolerance (dB)	RF Filter	Part Marking	Package	Shipping Method	Standard Quantity
02730A0006*	+/- 2	No	A240	8-Pad LGA	13" Reel	5,700
02730A0007*						
02730A0029	+/- 1	Yes	A241			
02730A0019	+/- 1.5	No	A242			

\*Not recommended for new designs

## 12. DOCUMENT REVISIONS

Rev. No	Description of modification/changes	Date
0.75	Released 0.75.	26-Aug-14
0.76	Updated first page description	25-Sep-14
0.77	Updated sensitivity tolerance	06-Oct-14
0.78	Updated current consumption	20-Oct-14
1.0	Released 1.0	06-Nov-14
1.01	Updated section 4	23-Dec-14

Akustica, Inc.  
 2835 E Carson St. Suite 301  
 Pittsburgh, PA / USA 15203

sales@akustica.com  
[www.akustica.com](http://www.akustica.com)

Modifications reserved | Printed in USA  
 Specifications subject to change without notice