

Description

The AL5814 is an 8-terminal adjustable linear LED driver-controller offering excellent temperature stability and output current capability. It works with a wide input voltage range from 4.5V to 60V. With an external LED driving power device, its internal power dissipation is minimized compared with traditional linear LED drivers. This makes it ideal for medium to high current LED circuits.

The AL5814 has internal output drive capability up to 15mA, which enables it to drive external Bipolar transistors or MOSFETs. It also provides the capability to drive longer LED chains with low drop-out voltage and multiple LED channels.

The VSET pin is used to directly set output current feedback level. Using a resistor divider between REF pin and VSET pin, the output current can be set. Additionally, the use of an NTC resistor allows the creation of an accurate and configurable thermal fold-back behavior.

The AL5814 provides an LED-open detection feature through its VFAULT pin. If VFAULT is brought lower than 2.5V (by any one of the multiple LED channels going open) the AL5814's output will go low turning off the external transistors. The device will recover when the open condition is removed. This ability of VFAULT to turn off the external transistors also allows PWM dimming of the LED current by adding PWM control signal on VFAULT pin.

The AL5814 uses application of power to enable the LED strings. If a separate enable pin is needed the AL5817 should be used.

The AL5814 is available in the thermally enhanced MSOP-8EP package.

Features

- Wide Input Voltage Range from 4.5V to 60V
- Configurable LED Current Setting
- 4% Reference Voltage Tolerance
- Low Temperature Drift
- 15mA Output Drive Capability for MOSFET or Bipolar Transistor
- LED Open Protection Detected by VFAULT Pin
- LED Thermal Fold-back Configured by VSET
- Over Temperature Protection (OTP)
- Input Under Voltage Lock-Out
- PWM Dimming Realized Through VFAULT pin
- **Totally Lead-Free & Fully RoHS Compliant (Notes 1 & 2)**
- **Halogen and Antimony Free. "Green" Device (Note 3)**

- Notes:
1. No purposely added lead. Fully EU Directive 2002/95/EC (RoHS), 2011/65/EU (RoHS 2) & 2015/863/EU (RoHS 3) compliant.
 2. See <https://www.diodes.com/quality/lead-free/> for more information about Diodes Incorporated's definitions of Halogen- and Antimony-free, "Green" and Lead-free.
 3. Halogen- and antimony-free "green" products are defined as those which contain <900ppm bromine, <900ppm chlorine (<1500ppm total Br + Cl) and <1000ppm antimony compounds.

Pin Assignments

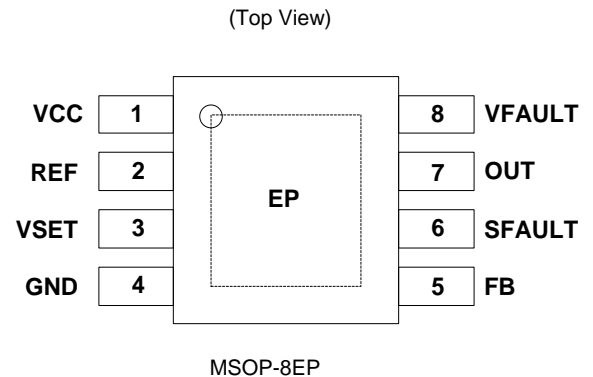

Applications

- Automotive Rear Combination Light
- LED Signs
- Instrumentation Illumination
- Refrigerator Lights

Typical Application Circuit

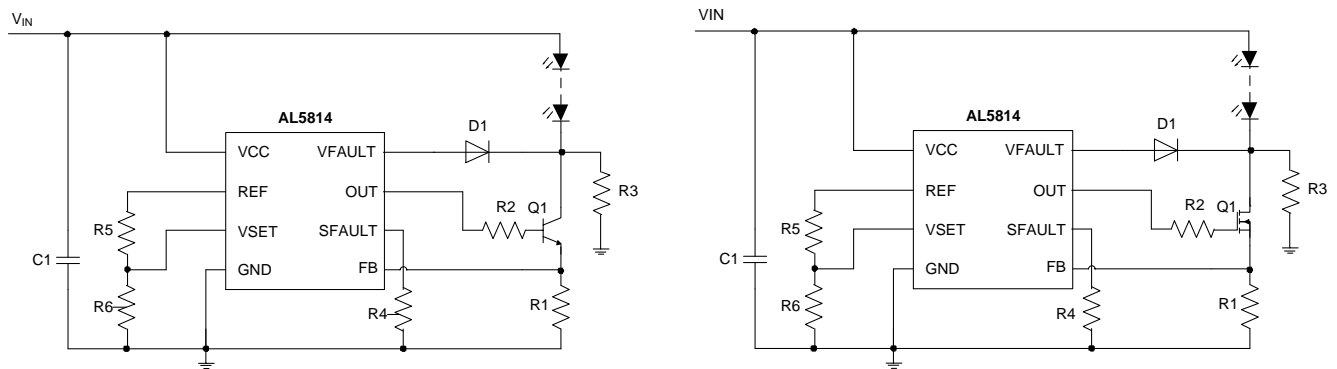
Figure 1

Pin Descriptions

| Pin Number | Pin Name | Function |
|------------|----------|---|
| 1 | VCC | Supply input |
| 2 | REF | Internal reference voltage. The maximum recommended output current is 50 μ A and the maximum recommended capacitor connected from this pin to GND is less than 100pF. A potential divider from REF to VSET can be used to accurately set the output LED current. |
| 3 | VSET | LED current setting threshold. The voltage on VSET sets the reference voltage for the FB pin. This pin is pulled down internally if left floating. The capacitance if needed between VSET and GND is recommended to be less than 1nF. |
| 4 | GND | Ground |
| 5 | FB | Feedback input. When control loop is operating in linear mode, the FB pin will be regulated to the level set by VSET. This pin is pulled up internally if left floating. A capacitor may be added between FB and GND to improve noise rejection. Value needs to be limited to 100pF or less. |
| 6 | SFAULT | VCC enable level setting for LED-open protection activation. Used in conjunction with VCC to determine 1. If LED-open is activated and 2. At what VCC voltage it becomes active This function prevents false triggering on power up. |
| 7 | OUT | Driving output |
| 8 | VFAULT | Input for LED-open detection. When LED-open detection function is active, if VFAULT is brought lower than approximately 2.5V, the device output will be turned off and will auto-retry driving the output to see if the fault still exists. A PWM dimming function will be realized by adding an open collector/drain signal on this pin. |
| EP | EP | Exposed Pad (Bottom). Recommended to be connected to a large-area contiguous copper GND plane for effective thermal dissipation. Do not use as the IC's only electrical GND connection. |

Functional Block Diagram

NEW PRODUCT

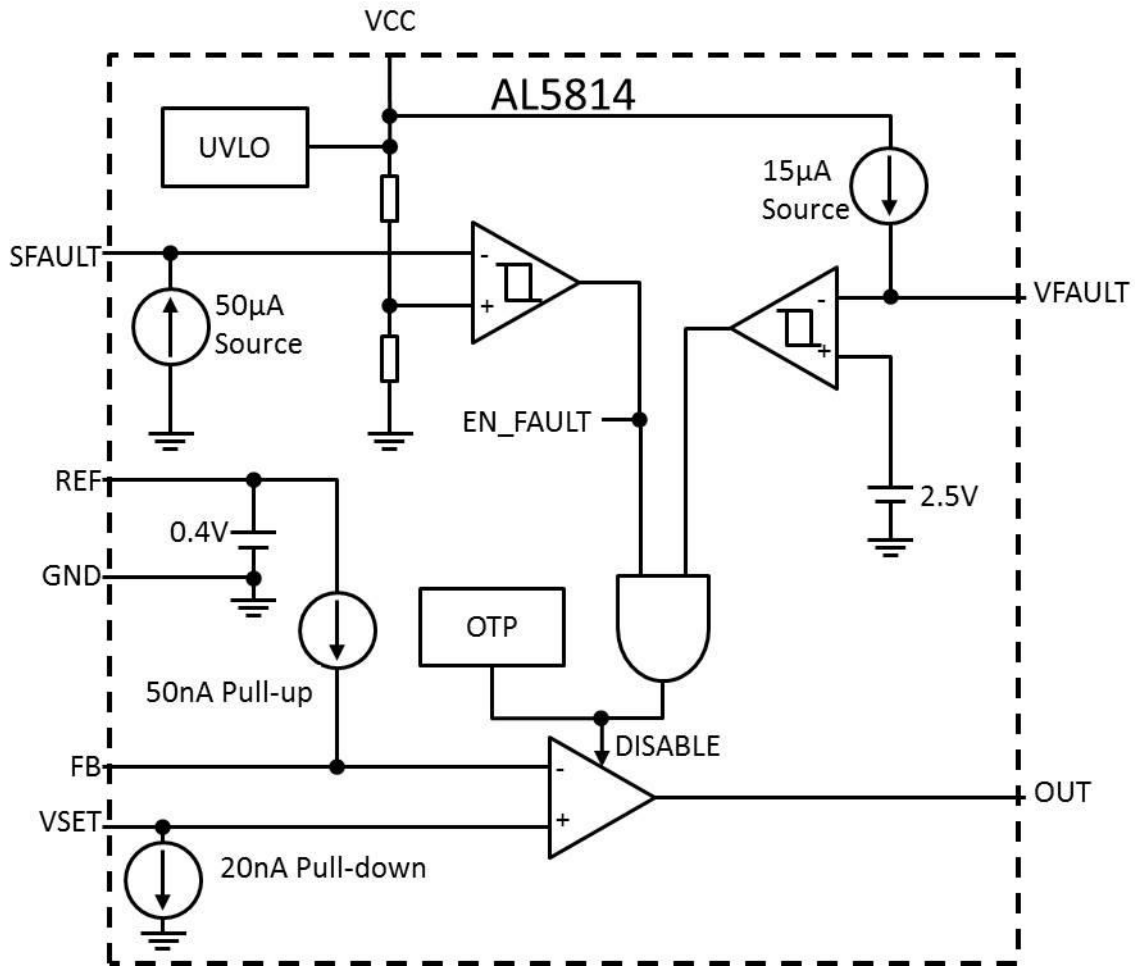

Figure 2

Absolute Maximum Ratings (Note 4)

| Symbol | Parameter | Rating | Unit |
|--|---|------------------|------|
| V_{VCC} | Supply Voltage Relative to GND | -0.3 to 65 | V |
| I_{VCC} | IC Supply Current | 18 | mA |
| V_{VFAULT} | Input Voltage Relative to GND | -0.3 to V_{CC} | V |
| $V_{REF}, V_{VSET}, V_{SFAULT}, V_{OUT}, V_{FB}$ | Input Voltage of REF, VSET, SFAULT, OUT, FB Relative to GND | -0.3 to 6 | V |
| T_J | Operating Junction Temperature | -40 to +150 | °C |
| T_{ST} | Storage Temperature | -55 to +150 | °C |

Note: 4. Stresses greater than those listed under "Absolute Maximum Ratings" may cause permanent damage to the device. These are stress ratings only, and functional operation of the device at these or any other conditions beyond those indicated under "Recommended Operating Conditions" is not implied. Exposure to Absolute Maximum Ratings for extended periods may affect device reliability.

ESD Ratings

| Symbol | Parameter | Rating | Unit |
|------------------|----------------------------|--------|------|
| V _{ESD} | Human-Body Model (HBM) | 2000 | V |
| | Charged-Device Model (CDM) | 1000 | |

Recommended Operating Conditions

| Symbol | Parameter | Min | Max | Unit |
|-------------------|--|-----|------|------|
| V _{VCC} | Supply Voltage Range Relative to GND Pin | 4.5 | 60 | V |
| V _{OUT} | OUT Voltage Range | 0 | 4 | V |
| I _{OUT} | OUT Pin Current | 0 | 15 | mA |
| V _{VSET} | VSET Pin Operating Input Voltage Range | 0 | 0.6 | V |
| T _J | Operating Junction Temperature Range | -40 | +125 | °C |
| T _A | Operating Ambient Temperature | -40 | +105 | °C |

Thermal Information (Notes 5 and 6)

| Symbol | Parameter | Rating | Unit |
|-----------------|---|--------|------|
| θ _{JA} | Junction-To-Ambient Thermal Resistance | 90 | °C/W |
| θ _{JC} | Junction-To-Case (Top) Thermal Resistance | 39 | °C/W |

- Note: 5. Dominant conduction path via exposed pad.
 6. Test condition for MSOP-8EP: Device mounted on FR-4 PCB (51mm x 51mm 2oz copper, minimum recommended pad layout on top layer and thermal vias to bottom layer ground plane. For better thermal performance, larger copper pad for heat-sink is needed.

Electrical Characteristics ($V_{CC} = 12V$ and $T_A = +25^{\circ}C$, unless otherwise specified.)

| Symbol | Parameter | Conditions | Min | Typ | Max | Unit |
|---------------------------------------|---|--|-------|-------|-------|-------------|
| Power Supply | | | | | | |
| V_{UVLO} | Under-Voltage Lock-out Voltage | V_{IN} Rising | - | 4.2 | 4.4 | V |
| | | V_{IN} Falling | 3.6 | 3.85 | - | |
| I_{CC} | Supply Current | $V_{CC} = 4.5V$ to $60V$, $I_{OUT} = 10mA$ | - | 10.25 | 11 | mA |
| I_Q | No Load Quiescent Current | $V_{CC} = 4.5V$ to $60V$, $I_{OUT} = 0$ | - | 0.25 | 1 | mA |
| Reference and Feedback Loop | | | | | | |
| V_{REF} | Reference Voltage | $V_{CC} = 4.5V$ to $60V$, $I_{OUT} = 0$, $I_{REF} = 20\mu A$ | 0.384 | 0.4 | 0.416 | V |
| V_{REF_LINE} | Reference Voltage Line Regulation | $V_{CC} = 4.5V$ to $19V$ | - | 0.2 | 3 | mV |
| V_{REF_LOAD} | Reference Voltage Load Regulation | $I_{REF} = 0$ to $-50\mu A$ | - | 1.4 | 6 | mV |
| I_{FB} | FB Input Bias Current | $V_{FB} = 0.2V$ | -200 | -125 | -80 | nA |
| I_{SET} | SET Input Bias Current | $V_{SET} = 0.6V$ | - | 25 | 45 | nA |
| V_{OFFSET} | V_{SET} to V_{FB} Offset | $V_{SET} = 0.2V$, $V_{FB} = V_{OUT}$ | - | - | 7 | mV |
| Fault Detection and Protection | | | | | | |
| I_{SFAULT} | Source Current from SFAULT Pin | $V_{CC} = 4.5V$ to $60V$ | -56 | -50 | -43 | μA |
| I_{VFAULT} | Source Current from VFAULT Pin | $V_{CC} = 4.5V$ to $60V$ | -20 | -15 | -10 | μA |
| V_{VFAULT} | VFAULT Pin Threshold Voltage | $V_{CC} = 4.5V$ to $60V$, V_{VFAULT} Falling | 2.37 | 2.5 | 2.63 | V |
| V_{VFAULT_HYS} | V_{VFAULT} Hysteresis | - | - | 100 | - | mV |
| t_{VF_OUTR} | VFAULT to OUT Rising Delay | - | - | 2 | - | μs |
| t_{VF_OUTF} | VFAULT to OUT Falling Delay | - | - | 1 | - | |
| T_{SHDN} | Thermal Shutdown | - | - | +160 | - | $^{\circ}C$ |
| T_{HYS} | Thermal Shutdown Hysteresis | - | - | +30 | - | $^{\circ}C$ |
| Output Driver Error Amplifier | | | | | | |
| $I_{OUTSOURCE}$ | Maximum Source Current $V_{SET} - V_{FB} = 10mV$ | $V_{OUT} = 0V$, $V_{CC} = 4.5V$ to $60V$ | - | - | -15 | mA |
| | | $V_{OUT} = 1V$, $V_{CC} = 4.5V$ to $60V$ | - | - | -15 | |
| | | $V_{OUT} = 2V$, $V_{CC} = 4.5V$ to $60V$ | - | - | -11 | |
| | | $V_{OUT} = 4V$, $V_{CC} = 6.0V$ to $60V$ | - | - | -5 | |
| $I_{OUTSINK}$ | Maximum Sink Current | $V_{CC} = 12V$, $V_{OUT} = 4V$, $V_{VFAULT} > 2.7V$, $V_{SET} - V_{FB} = -50mV$ | 20 | - | - | μA |
| | | $V_{CC} = 12V$, $V_{OUT} = 4V$, VFAULT enabled by SFAULT $V_{SET} - V_{FB} = -50mV$, $V_{VFAULT} < 2.3V$ | 0.3 | - | - | mA |
| G_m | Trans-Conductance of Error Amplifier | $V_{SET} - V_{FB} = 5mV$, Sourcing Current | - | 4 | - | A/V |
| BW | Bandwidth | - | - | 50 | - | kHz |
| V_{OUTMAX} | Maximum Output Voltage | $V_{CC} \geq 6V$, $I_{OUT} = -1mA$ | 4 | - | - | V |
| V_{OUTMIN} | Minimum Output Voltage | $V_{CC} = 12V$, $I_{OUT} = 0.1mA$, $V_{FB} = 250mV$ | - | - | 300 | mV |

Typical Performance Characteristics ($V_{CC} = 12V$, $T_A = +25^\circ C$, unless otherwise specified.)

NEW PRODUCT

Supply Current vs. Temperature

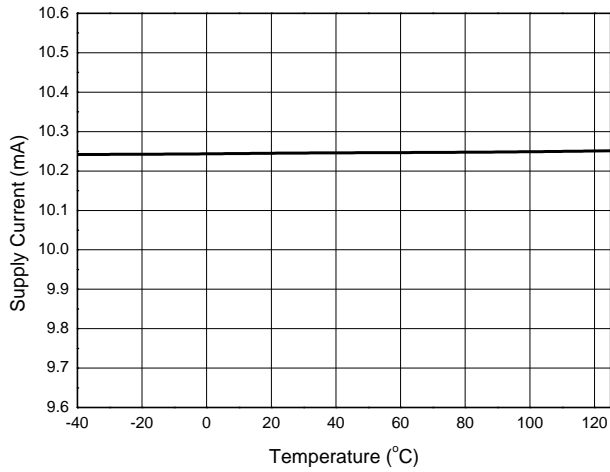

Quiescent Current vs. Temperature

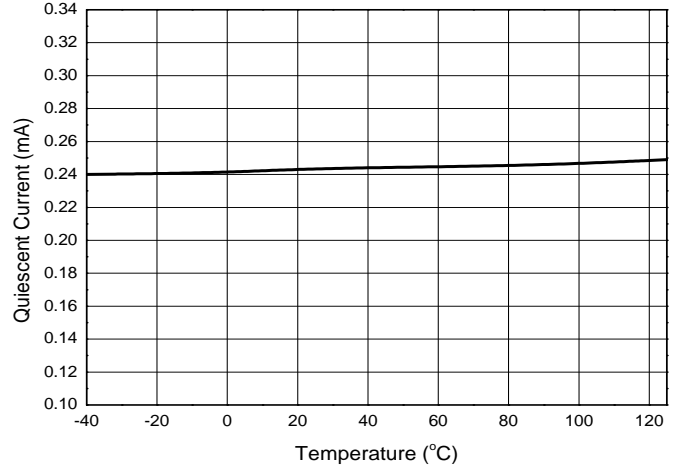

V_{UVLO} vs. Temperature

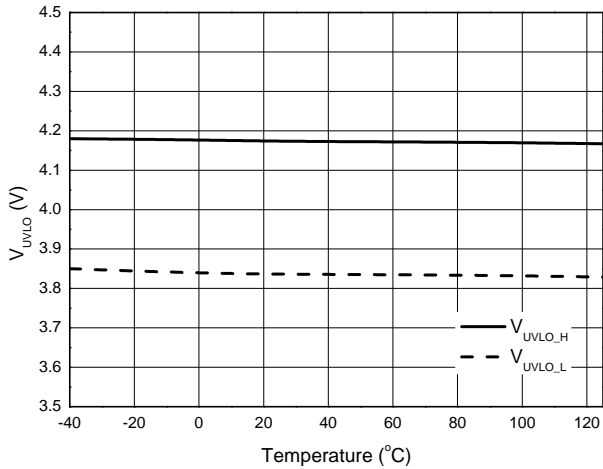

V_{REF} vs. Temperature

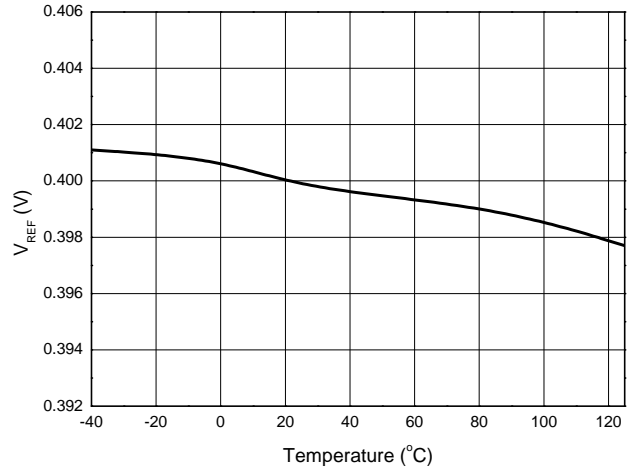

I_{SFAULT} vs. Temperature

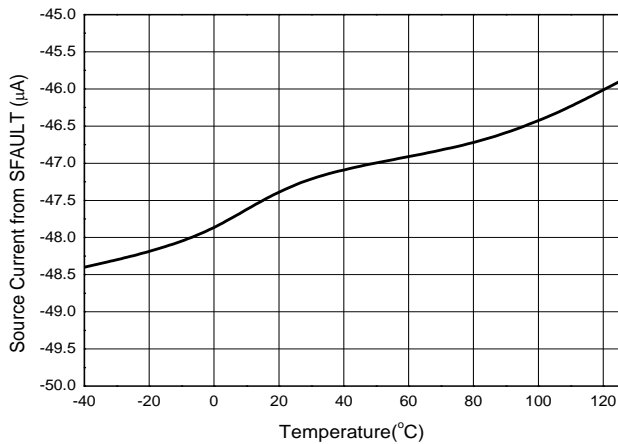

I_{VFAULT} vs. Temperature

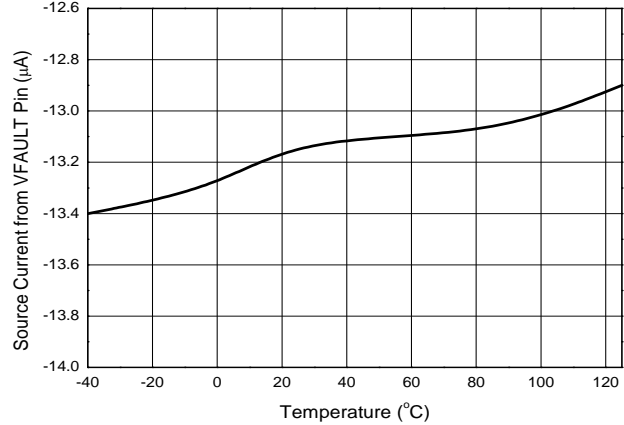

Typical Performance Characteristics (Cont.) ($V_{CC} = 12V$, $T_A = +25^\circ C$, unless otherwise specified.)

V_{FAULT} vs. Temperature

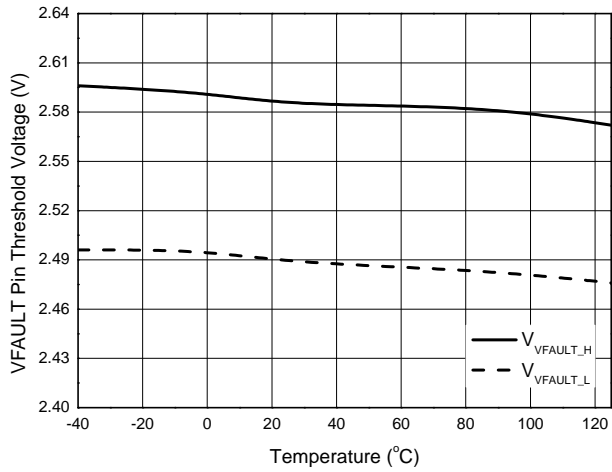

Source Current vs. Temperature

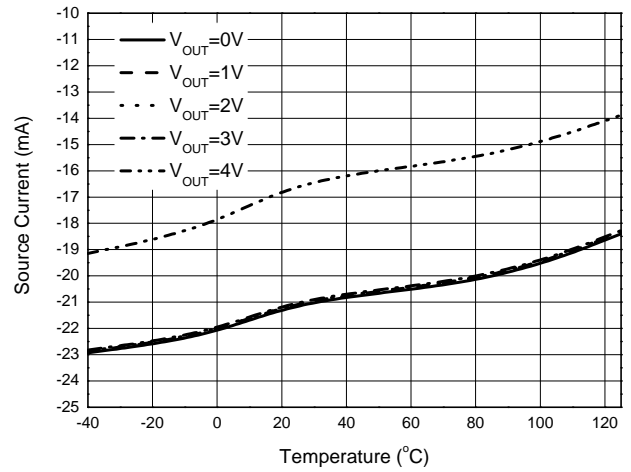

NEW PRODUCT

Application Information

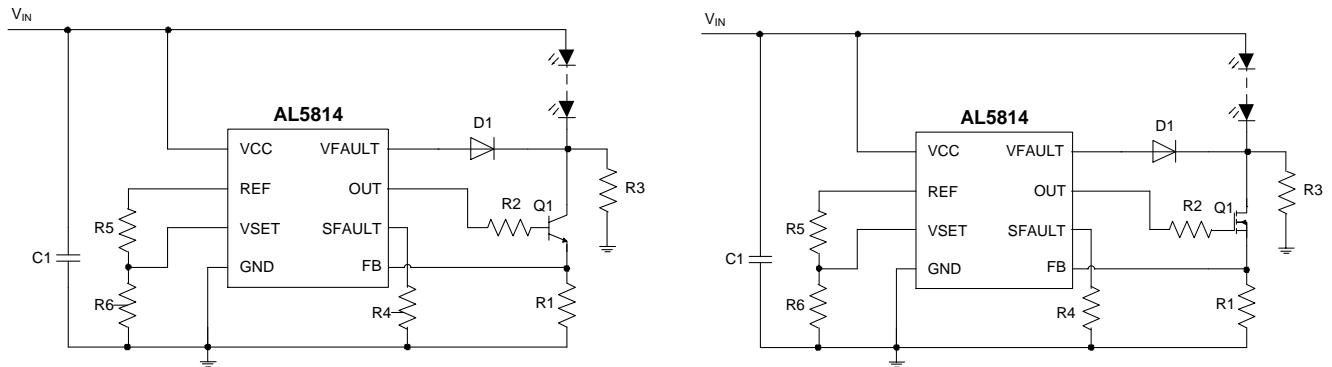

Figure 3. Typical Application

Output Drive

Figure 3 shows the typical output drive configuration. The feedback loop regulates the current through the external LEDs. The voltage across the external sense resistor (R1) is fed to the FB pin for sensing. When the voltage exceeds V_{SET} voltage the OUT goes lower, decreasing the drive to the external transistor.

The output current can be set as following:

$$I_{LED} = \frac{V_{VSET}}{R_1} \quad (1)$$

Where I_{LED} is the desired LED current, V_{VSET} is determined by R5 and R6 resistor divider and R₁ is the sense resistor.

The power in the sense resistor is calculated as:

$$Power = V_{VSET} * I_{LED}$$

Where V_{VSET} = VSET voltage and I_{LED} is the desired LED string current. For most cases, a standard 1/4W resistor will work. Similarly, the external transistor's power dissipation also must be considered to prevent thermal damage to the transistor, which can further damage the LED controller IC.

Power Consideration of the NMOS or BJT Device

The power rating of the transistor (either BJT or NMOS) used in the typical application circuit is important. A correctly mounted transistor used in a typical application can dissipate power of up to 2 W. To calculate power dissipation, first calculate the voltage drop across the transistor as follows:

$$V_{DS} = V_{CC} - V_{LED} - V_{VSET}$$

Then calculate the power dissipation requirement:

$$Power = V_{DS} * I_{LED}$$

If power dissipation is higher than the transistor package and layout can dissipate then a higher power dissipation transistor must be selected and/or use a better PCB layout.

Multiple LED Strings in Parallel

The AL5814 can drive more than one channel of LED strings. As shown in Figure 4, the sense voltage of two channels' (or more) output current can be implemented by connecting the voltage of one sense resistor to the FB pin.

By utilizing the same type transistors, sense resistors and series base resistors, the currents in all channels will match.

Application Information (Cont.)

NEW PRODUCT

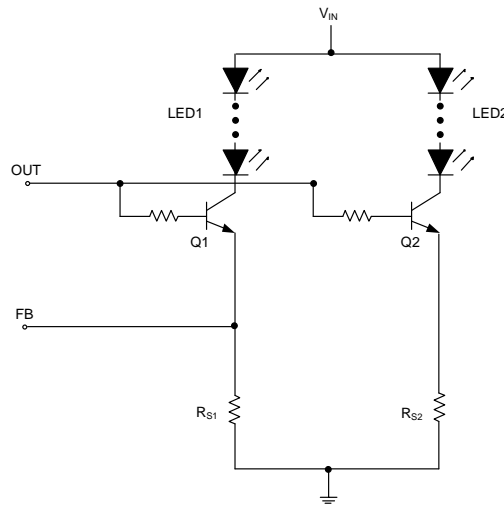

Figure 4. Two LED Strings in Parallel

The output current can be set as following: $I_{LED1} = I_{LED2} = \dots = V_{FB} / R_{S1}$

Where I_{LEDx} is the desired LED current, V_{FB} is V_{VSET} , and R_{S1} is the sense resistor. To keep the LED currents as equal as possible, transistors Q1 and Q2 should be matched, and R_{S1} and R_{S2} should be matched.

Open Load Detection

SFAULT Setup:

The AL5814 can be configured to detect the presence of the LEDs on the external output transistor going open circuit. This function is activated by the SFAULT pin. A 50µA current source from SFAULT creates a voltage (V_{SFAULT}) across an external resistor (R7) which is compared to potential divided down VCC voltage see Figure 5 (blue components are internal to the AL5814).

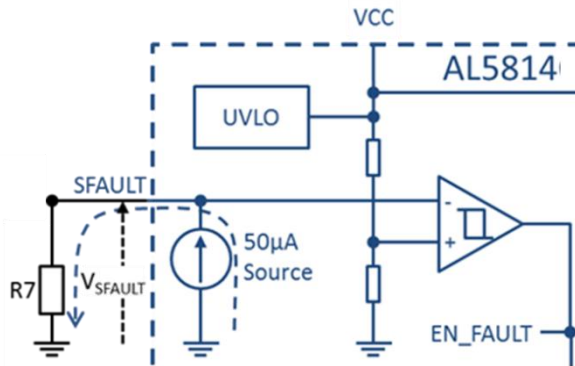

Figure 5. SFAULT Configuration

Once V_{CC} has risen to above the set voltage on the VSFAULT pin the EN_FAULT becomes high and LED-open detection becomes functional. This avoids false triggering of open load protection during start up and power down procedure.

Supply voltage at which LED-open detection become operational is set by the following equation:

$$V_{CC} = 11 \times 50 \times 10^{-6} \times R7$$

Application Information (Cont.)

The table below shows some approximate supply voltages that the LED-open detection becomes active by different resistor values.

| V _{CC} (V) | R7 (kΩ) |
|---------------------|---------|
| 5.01 | 9.1 |
| 5.50 | 10 |
| 6.60 | 12 |
| 8.25 | 15 |
| 9.90 | 18 |
| 11.55 | 21 |

If SFAULT is shorted to GND then by default LED-open fault detection is automatically entered. If SFAULT is left open then LED-open detection is inhibited.

VFAULT

The AL5814 detects open conditions on the collector/drain of the external transistor driving the LEDs using the VFAULT pin, see Figure 6. The VFAULT pin has a 14μA current source generated out of this pin.

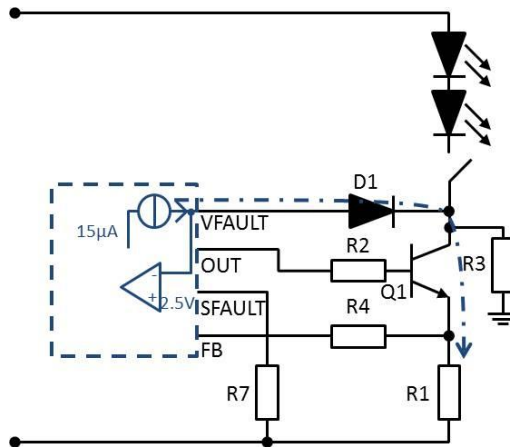

Figure 6. LED-Open Detection Using VFAULT

If the LED string becomes open, VFAULT pin will be pulled down by the power bipolar or MOSFET below its internal 2.5V threshold. This condition triggers an output disable condition causing OUT to go low, turning off the external MOSFET/BJT. A resistor (R3, 100K) is needed to keep the VFAULT signal low during a fault condition. A 100kΩ will keep this node low. When the fault condition is fixed and VFAULT pin rises above 2.63V the device will operate normally.

Feedback Loop

The device has internal compensation and therefore it is not recommended that any components are added to the feedback loop.

LED Thermal Compensation

The LED current is set by the reference voltage at the emitter/drain voltage of the LED driving transistor. This reference voltage is determined by the resistor divider between REF and VSET. The LED driver's LED current behavior under different ambient or LED temperatures can be configured by using NTC for R6 shown in Figure 7.

NEW PRODUCT

Application Information (Cont.)

NEW PRODUCT

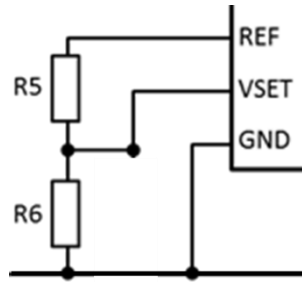

Figure 7

In the example shown in

Figure 8, the resistor network is comprised of one NTC and a resistor. When the temperature of the detecting point is rising, the NTC resistance will decrease and make the voltage at VSET decrease also, consequentially, the output current will decrease to prevent the system from over-heated.

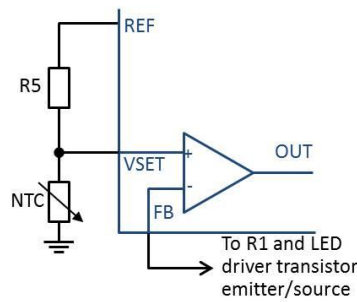
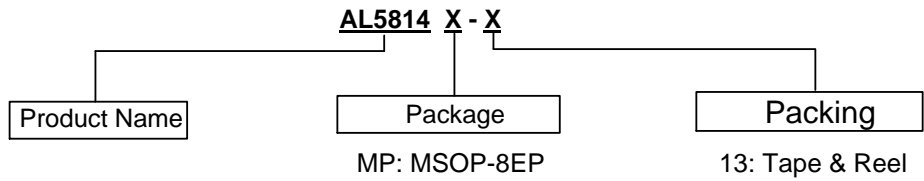

Figure 8. Thermal Fold Back Circuit Basing on NTC

Thermal Protection

The AL5814 has an internal Over Temperature Protection (OTP). When the junction temperature is over +160°C, the IC will shut down. When the junction temperature drops by +30°C the IC turn back on.

Ordering Information (Note 7)



| Part Number | Package Code | Packaging | 13" Tape and Reel | |
|-------------|--------------|-----------|-------------------|--------------------|
| | | | Quantity | Part Number Suffix |
| AL5814MP-13 | MP | MSOP-8EP | 2500 | -13 |

Note: 7. For packaging details, go to our website at <https://www.diodes.com/design/support/packaging/diodes-packaging/>.

Marking Information

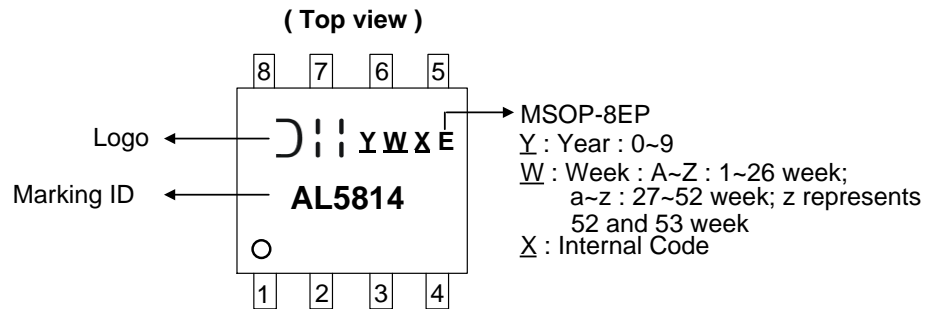

| Device | Package |
|-------------|----------|
| AL5814MP-13 | MSOP-8EP |

NEW PRODUCT

Package Outline Dimensions

Please see <http://www.diodes.com/package-outlines.html> for the latest version.

MSOP-8EP

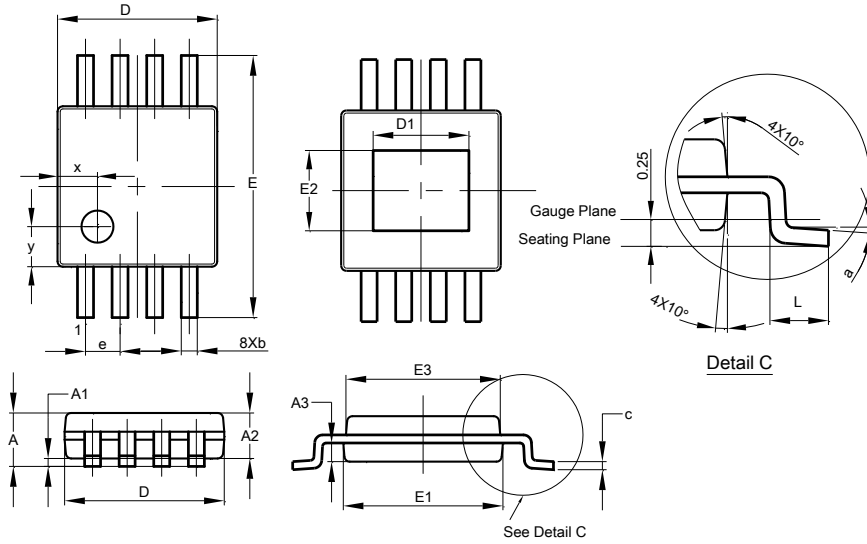

| MSOP-8EP | | | |
|----------------------|------|------|-------|
| Dim | Min | Max | Typ |
| A | - | 1.10 | - |
| A1 | 0.05 | 0.15 | 0.10 |
| A2 | 0.75 | 0.95 | 0.86 |
| A3 | 0.29 | 0.49 | 0.39 |
| b | 0.22 | 0.38 | 0.30 |
| c | 0.08 | 0.23 | 0.15 |
| D | 2.90 | 3.10 | 3.00 |
| D1 | 1.60 | 2.00 | 1.80 |
| E | 4.70 | 5.10 | 4.90 |
| E1 | 2.90 | 3.10 | 3.00 |
| E2 | 1.30 | 1.70 | 1.50 |
| E3 | 2.85 | 3.05 | 2.95 |
| e | - | - | 0.65 |
| L | 0.40 | 0.80 | 0.60 |
| a | 0° | 8° | 4° |
| x | - | - | 0.750 |
| y | - | - | 0.750 |
| All Dimensions in mm | | | |

Suggested Pad Layout

Please see <http://www.diodes.com/package-outlines.html> for the latest version.

MSOP-8EP

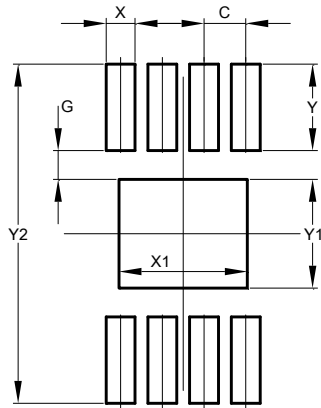

| Dimensions | Value (in mm) |
|------------|---------------|
| C | 0.650 |
| G | 0.450 |
| X | 0.450 |
| X1 | 2.000 |
| Y | 1.350 |
| Y1 | 1.700 |
| Y2 | 5.300 |

IMPORTANT NOTICE

DIODES INCORPORATED MAKES NO WARRANTY OF ANY KIND, EXPRESS OR IMPLIED, WITH REGARDS TO THIS DOCUMENT, INCLUDING, BUT NOT LIMITED TO, THE IMPLIED WARRANTIES OF MERCHANTABILITY AND FITNESS FOR A PARTICULAR PURPOSE (AND THEIR EQUIVALENTS UNDER THE LAWS OF ANY JURISDICTION).

Diodes Incorporated and its subsidiaries reserve the right to make modifications, enhancements, improvements, corrections or other changes without further notice to this document and any product described herein. Diodes Incorporated does not assume any liability arising out of the application or use of this document or any product described herein; neither does Diodes Incorporated convey any license under its patent or trademark rights, nor the rights of others. Any Customer or user of this document or products described herein in such applications shall assume all risks of such use and will agree to hold Diodes Incorporated and all the companies whose products are represented on Diodes Incorporated website, harmless against all damages.

Diodes Incorporated does not warrant or accept any liability whatsoever in respect of any products purchased through unauthorized sales channel. Should Customers purchase or use Diodes Incorporated products for any unintended or unauthorized application, Customers shall indemnify and hold Diodes Incorporated and its representatives harmless against all claims, damages, expenses, and attorney fees arising out of, directly or indirectly, any claim of personal injury or death associated with such unintended or unauthorized application.

Products described herein may be covered by one or more United States, international or foreign patents pending. Product names and markings noted herein may also be covered by one or more United States, international or foreign trademarks.

This document is written in English but may be translated into multiple languages for reference. Only the English version of this document is the final and determinative format released by Diodes Incorporated.

LIFE SUPPORT

Diodes Incorporated products are specifically not authorized for use as critical components in life support devices or systems without the express written approval of the Chief Executive Officer of Diodes Incorporated. As used herein:

A. Life support devices or systems are devices or systems which:

1. are intended to implant into the body, or
2. support or sustain life and whose failure to perform when properly used in accordance with instructions for use provided in the labeling can be reasonably expected to result in significant injury to the user.

B. A critical component is any component in a life support device or system whose failure to perform can be reasonably expected to cause the failure of the life support device or to affect its safety or effectiveness.

Customers represent that they have all necessary expertise in the safety and regulatory ramifications of their life support devices or systems, and acknowledge and agree that they are solely responsible for all legal, regulatory and safety-related requirements concerning their products and any use of Diodes Incorporated products in such safety-critical, life support devices or systems, notwithstanding any devices- or systems-related information or support that may be provided by Diodes Incorporated. Further, Customers must fully indemnify Diodes Incorporated and its representatives against any damages arising out of the use of Diodes Incorporated products in such safety-critical, life support devices or systems.

Copyright © 2018, Diodes Incorporated

www.diodes.com