



REALTEK

ALC5610-GR
ALC5610-GRT

AC'97 AUDIO CODEC + TOUCH PANEL CONTROLLER + VOICE PCM INTERFACE

DATASHEET

Rev. 1.2
11 January 2008
Track ID: JATR-1076-21



Realtek Semiconductor Corp.

No. 2, Innovation Road II, Hsinchu Science Park, Hsinchu 300, Taiwan

Tel.: +886-3-578-0211. Fax: +886-3-577-6047

www.realtek.com.tw

COPYRIGHT

©2008 Realtek Semiconductor Corp. All rights reserved. No part of this document may be reproduced, transmitted, transcribed, stored in a retrieval system, or translated into any language in any form or by any means without the written permission of Realtek Semiconductor Corp.

DISCLAIMER

Realtek provides this document “as is”, without warranty of any kind, neither expressed nor implied, including, but not limited to, the particular purpose. Realtek may make improvements and/or changes in this document or in the product described in this document at any time. This document could include technical inaccuracies or typographical errors.

TRADEMARKS

Realtek is a trademark of Realtek Semiconductor Corporation. Other names mentioned in this document are trademarks/registered trademarks of their respective owners.

USING THIS DOCUMENT

This document is intended for the hardware and software engineer’s general information on the Realtek ALC5610 Audio Codec IC.

Though every effort has been made to ensure that this document is current and accurate, more information may have become available subsequent to the production of this guide. In that event, please contact your Realtek representative for additional information that may help in the development process.

REVISION HISTORY

Revision	Release Date	Summary
1.0	2007/06/07	First release
1.1	2007/08/15	Revised Table 85, page 68. Added section 9.1.2 Recommended Operating Conditions, page 68.
1.2	2008/01/11	Revised section 1 General Description, page 1. Revised Figure 1, page 4. Revised Figure 2, page 5. Added note in Table 4, page 9. Revised Figure 7 to Figure 14, page 15 to 17. Revised section 7.8.1 Speaker Output, page 24. Revised section 7.9 Touch Panel Control, page 26. Revised Table 21, page 36. Revised Table 32, page 41. Revised Table 33, page 42. Revised Table 36, page 45. Revised Table 86, page 68. Revised section 10 Application Circuits, page 76. Revised section 13 Ordering Information, page 81.

Table of Contents

1. GENERAL DESCRIPTION	1
2. FEATURES	2
3. SYSTEM APPLICATIONS	3
4. FUNCTION BLOCK DIAGRAM.....	4
4.1. FUNCTION BLOCK	4
4.2. AUDIO MIXER PATH	5
5. PIN ASSIGNMENTS.....	6
5.1. GREEN PACKAGE AND VERSION IDENTIFICATION	6
6. PIN DESCRIPTIONS.....	7
6.1. AC'97 DIGITAL I/O PINS	7
6.2. ANALOG I/O PINS	8
6.3. FILTER/REFERENCE	8
6.4. POWER/GROUND	9
7. FUNCTIONAL DESCRIPTION	10
7.1. POWER	10
7.2. RESET	10
7.2.1. <i>Power-On Reset (POR)</i>	10
7.3. CLOCKING	11
7.3.1. <i>Phase-Locked Loop</i>	11
7.3.2. <i>AC'97 Mode</i>	12
7.3.3. <i>Voice I²S/PCM Interface</i>	12
7.3.4. <i>Voice ADC</i>	12
7.4. DIGITAL DATA INTERFACE	13
7.4.1. <i>AC-Link</i>	13
7.4.2. <i>Voice I²S/PCM Interface</i>	15
7.5. AUDIO DATA PATH	19
7.5.1. <i>Stereo ADC and Voice ADC</i>	19
7.5.2. <i>Stereo DAC</i>	19
7.5.3. <i>Voice to Stereo Digital Path</i>	19
7.5.4. <i>Voice DAC</i>	20
7.6. MIXERS	20
7.6.1. <i>Headphone Mixer</i>	20
7.6.2. <i>MONO Mixer</i>	21
7.6.3. <i>Speaker Mixer</i>	21
7.6.4. <i>ADC Record Mixer</i>	22
7.7. ANALOG AUDIO INPUT PATH	22
7.7.1. <i>Line Input</i>	22
7.7.2. <i>Phone Input</i>	23
7.7.3. <i>Microphone Input</i>	23
7.7.4. <i>MICIN/AUX3 and MICBIAS2/AUX4 Pin Sharing</i>	23
7.8. ANALOG AUDIO OUTPUT DATA PATH	24
7.8.1. <i>Speaker Output</i>	24
7.8.2. <i>Headphone Output</i>	25
7.8.3. <i>MONO Output</i>	25
7.9. TOUCH PANEL CONTROL	26

7.10.	AVC CONTROL	27
7.11.	HARDWARE SOUND EFFECTS	28
7.11.1.	Equalizer Block.....	28
7.11.2.	Pseudo Stereo and Spatial 3D Sound.....	28
7.12.	ODD-ADDRESSED REGISTER ACCESS.....	28
7.13.	POWER MANAGEMENT.....	29
7.13.1.	Sleep Mode	29
7.14.	GPIO AND INTERRUPT	30
8.	MIXER REGISTERS LIST.....	31
8.1.	REG-00H: RESET	31
8.2.	REG-02H: SPEAKER OUTPUT VOLUME.....	31
8.3.	REG-04H: HEADPHONE OUTPUT VOLUME.....	32
8.4.	REG-08H: PHONE INPUT/MONO OUTPUT VOLUME.....	32
8.5.	REG-0AH: LINE_IN VOLUME	33
8.6.	REG-0CH: STEREO DAC VOLUME.....	33
8.7.	REG-0EH: MIC VOLUME	34
8.8.	REG-10H: MIC ROUTING CONTROL.....	34
8.9.	REG-12H: ADC RECORD GAIN.....	35
8.10.	REG-14H: ADC RECORD MIXER CONTROL.....	35
8.11.	REG-18H: VOICE DAC OUTPUT VOLUME	36
8.12.	REG-1CH: OUTPUT MIXER CONTROL	36
8.13.	REG-22H: MICROPHONE CONTROL	37
8.14.	REG-26H: POWER DOWN CONTROL/STATUS	37
8.15.	REG-2AH: TONE CONTROL	39
8.16.	REG-2CH: AC'97 STEREO DAC RATE/DPE RATE	39
8.17.	REG-32H: AC'97 STEREO ADC RATE	40
8.18.	REG-36H: EXTEND SERIAL DATA PORT CONTROL (VoDAC_I2S/PCM).....	40
8.19.	REG-3AH: POWER MANAGEMENT ADDITION 1	41
8.20.	REG-3CH: POWER MANAGEMENT ADDITION 2	42
8.21.	REG-3EH: POWER MANAGEMENT ADDITION 3	43
8.22.	REG-40H: GENERAL PURPOSE CONTROL REGISTER 1	44
8.23.	REG-42H: GENERAL PURPOSE CONTROL REGISTER 2	45
8.24.	REG-44H: PLL CONTROL	45
8.24.1.	AC-Link PLL Clock Setting Table (Unit: MHz)	46
8.25.	REG-4CH: GPIO PIN CONFIGURATION.....	46
8.26.	REG-4EH: GPIO PIN POLARITY	47
8.27.	REG-50H: GPIO PIN STICKY	47
8.28.	REG-52H: GPIO PIN WAKE-UP	48
8.29.	REG-54H: GPIO PIN STATUS	49
8.30.	REG-56H: PIN SHARING	49
8.31.	REG-58H: OVER-TEMP/CURRENT STATUS.....	51
8.32.	REG-5CH: GPIO_OUTPUT PIN CONTROL.....	52
8.33.	REG-5EH: MISC CONTROL.....	52
8.34.	REG-64H: VoDAC_PCM CLOCK CONTROL_1	54
8.35.	REG-66H: VoDAC_PCM CLOCK CONTROL_2	55
8.36.	REG-68H: PSEUDO STEREO AND SPATIAL EFFECT BLOCK CONTROL	56
8.37.	REG-6AH: INDEX ADDRESS.....	57
8.38.	REG-6CH: INDEX DATA.....	57
8.39.	REG-6EH: EQ STATUS.....	57
8.40.	INDEX-00H: EQ BAND-0 COEFFICIENT (LP0: A1)	58
8.41.	INDEX-01H: EQ BAND-0 GAIN (LP0: Ho).....	58
8.42.	INDEX-02H: EQ BAND-1 COEFFICIENT (BP1: A1)	58
8.43.	INDEX-03H: EQ BAND-1 COEFFICIENT (BP1: A2)	58
8.44.	INDEX-04H: EQ BAND-1 GAIN (BP1: Ho)	59

8.45.	INDEX-05H: EQ BAND-2 COEFFICIENT (BP2: A1)	59
8.46.	INDEX-06H: EQ BAND-2 COEFFICIENT (BP2: A2)	59
8.47.	INDEX-07H: EQ BAND-2 GAIN (BP2: HO)	59
8.48.	INDEX-08H: EQ BAND-3 COEFFICIENT (BP3: A1)	60
8.49.	INDEX-09H: EQ BAND-3 COEFFICIENT (BP3: A2)	60
8.50.	INDEX-0AH: EQ BAND-3 GAIN (BP3: HO).....	60
8.51.	INDEX-0BH: EQ BAND-4 COEFFICIENT (HPF: A1)	60
8.52.	INDEX-0CH: EQ BAND-4 GAIN (HPF: HO)	60
8.53.	INDEX-10H: EQ CONTROL AND STATUS REGISTER	61
8.54.	INDEX-11H: EQ INPUT VOLUME CONTROL	61
8.55.	INDEX-12H: EQ OUTPUT VOLUME CONTROL	61
8.56.	INDEX-20H: AUTO VOLUME CONTROL REGISTER 0	62
8.57.	INDEX-21H: AUTO VOLUME CONTROL REGISTER 1	62
8.58.	INDEX-22H: AUTO VOLUME CONTROL REGISTER 2	62
8.59.	INDEX-23H: AUTO VOLUME CONTROL REGISTER 3	63
8.60.	INDEX-24H: AUTO VOLUME CONTROL REGISTER 4	63
8.61.	INDEX-25H: AUTO VOLUME CONTROL REGISTER 5	63
8.62.	INDEX-39H: DIGITAL INTERNAL REGISTER.....	63
8.63.	INDEX-4AH: CLASS D TEMPERATURE SENSOR.....	64
8.64.	INDEX-54H: AD_DA_MIXER_INTERNAL REGISTER	64
8.65.	REG-74H: TOUCH PANEL CONTROL BYTE 1	65
8.66.	REG-76H: TOUCH PANEL CONTROL BYTE 2	66
8.67.	REG-78H: TOUCH PANEL INDICATION.....	67
8.68.	REG-7CH: VENDOR ID 1	67
8.69.	REG-7EH: VENDOR ID 2.....	67
9.	ELECTRICAL CHARACTERISTICS.....	68
9.1.	DC CHARACTERISTICS.....	68
9.1.1.	<i>Absolute Maximum Ratings</i>	68
9.1.2.	<i>Recommended Operating Conditions</i>	68
9.1.3.	<i>Static Characteristics</i>	68
9.2.	ANALOG PERFORMANCE CHARACTERISTICS.....	69
9.3.	SIGNAL TIMING	72
9.3.1.	<i>Cold Reset</i>	72
9.3.2.	<i>Warm Reset</i>	72
9.3.3.	<i>AC-Link Clock Parameters</i>	73
9.3.4.	<i>AC-Link Data Output and Input Timing</i>	73
9.3.5.	<i>AC-Link Signal Rise and Fall Timing</i>	74
9.3.6.	<i>AC-Link Low Power Mode Timing</i>	75
9.3.7.	<i>AC-Link IO Pin Capacitance and Loading</i>	75
10.	APPLICATION CIRCUITS	76
11.	MECHANICAL DIMENSIONS	77
12.	APPENDIX A: VOICE PCM INTERFACE.....	78
12.1.	MASTER MODE: (VOICE_PORT_SEL=0).....	78
12.2.	SLAVE MODE: (VOICE_PORT_SEL=1)	80
13.	ORDERING INFORMATION	81

List of Tables

TABLE 1.	AC'97 DIGITAL I/O PINS	7
TABLE 2.	ANALOG I/O PINS	8
TABLE 3.	FILTER/REFERENCE	8
TABLE 4.	POWER/GROUND	9
TABLE 5.	POWER SETTING FOR BEST PERFORMANCE	10
TABLE 6.	RESET OPERATION	10
TABLE 7.	POWER-ON RESET VOLTAGE	10
TABLE 8.	AC-LINK CLOCK SETTING TABLE (UNIT: MHZ)	11
TABLE 9.	I ² S SIGNAL LINK MASTER MODE CLOCK TABLE	18
TABLE 10.	PIN SHARING CONFIGURATION TABLE	23
TABLE 11.	REG-00H: RESET	31
TABLE 12.	REG-02H: SPEAKER OUTPUT VOLUME	31
TABLE 13.	REG-04H: HEADPHONE OUTPUT VOLUME	32
TABLE 14.	REG-08H: PHONE INPUT/MONO OUTPUT VOLUME	32
TABLE 15.	REG-0AH: LINE_IN VOLUME	33
TABLE 16.	REG-0CH: STEREO DAC VOLUME	33
TABLE 17.	REG-0EH: MIC VOLUME	34
TABLE 18.	REG-10H: MIC ROUTING CONTROL	34
TABLE 19.	REG-12H: ADC RECORD GAIN	35
TABLE 20.	REG-14H: ADC RECORD MIXER CONTROL	35
TABLE 21.	REG-18H: VOICE DAC OUTPUT VOLUME	36
TABLE 22.	REG-1CH: OUTPUT MIXER CONTROL	36
TABLE 23.	REG-22H: MICROPHONE CONTROL	37
TABLE 24.	REG-26H: POWER DOWN CONTROL/STATUS	37
TABLE 25.	TRUTH TABLE FOR POWER DOWN MODE (PD=POWER DOWN)	38
TABLE 26.	REG-2AH: TONE CONTROL	39
TABLE 27.	REG-2CH: AC'97 STEREO DAC RATE/DPE RATE	39
TABLE 28.	PC99/PC2001 DESIGN GUIDE SAMPLING RATES	39
TABLE 29.	REG-32H: AC'97 STEREO ADC RATE	40
TABLE 30.	PC99/PC2001 DESIGN GUIDE SAMPLING RATES	40
TABLE 31.	REG-36H: EXTEND SERIAL DATA PORT CONTROL (VoDAC_I2S/PCM)	40
TABLE 32.	REG-3AH: POWER MANAGEMENT ADDITION 1	41
TABLE 33.	REG-3CH: POWER MANAGEMENT ADDITION 2	42
TABLE 34.	REG-3EH: POWER MANAGEMENT ADDITION 3	43
TABLE 35.	REG-40H: GENERAL PURPOSE CONTROL REGISTER 1	44
TABLE 36.	REG-42H: GENERAL PURPOSE CONTROL REGISTER 2	45
TABLE 37.	REG-44H: PLL CONTROL	45
TABLE 38.	AC-LINK PLL CLOCK SETTING TABLE (UNIT: MHZ)	46
TABLE 39.	REG-4CH: GPIO PIN CONFIGURATION	46
TABLE 40.	REG-4EH: GPIO PIN POLARITY	47
TABLE 41.	REG-50H: GPIO PIN STICKY	47
TABLE 42.	REG-52H: GPIO PIN WAKE-UP	48
TABLE 43.	REG-54H: GPIO PIN STATUS	49
TABLE 44.	REG-56H: PIN SHARING	49
TABLE 45.	GPIO AND IRQ LOGIC	50
TABLE 46.	REG-58H: OVER-TEMP/CURRENT STATUS	51
TABLE 47.	REG-5CH: GPIO_OUTPUT PIN CONTROL	52
TABLE 48.	REG-5EH: MISC CONTROL	52
TABLE 49.	REG-64H: VoDAC_PCM CLOCK CONTROL_1	54
TABLE 50.	REG-66H: VoDAC_PCM CLOCK CONTROL_2	55
TABLE 51.	REG-68H: PSEUDO STEREO AND SPATIAL EFFECT BLOCK CONTROL	56

TABLE 52.	REG-6AH: INDEX ADDRESS	57
TABLE 53.	REG-6CH: INDEX DATA	57
TABLE 54.	REG-6EH: EQ STATUS	57
TABLE 55.	INDEX-00H: EQ BAND-0 COEFFICIENT (LP0: A1)	58
TABLE 56.	INDEX-01H: EQ BAND-0 GAIN (LP0: HO)	58
TABLE 57.	INDEX-02H: EQ BAND-1 COEFFICIENT (BP1: A1)	58
TABLE 58.	INDEX-03H: EQ BAND-1 COEFFICIENT (BP1: A2)	58
TABLE 59.	INDEX-04H: EQ BAND-1 GAIN (BP1: HO)	59
TABLE 60.	INDEX-05H: EQ BAND-2 COEFFICIENT (BP2: A1)	59
TABLE 61.	INDEX-06H: EQ BAND-2 COEFFICIENT (BP2: A2)	59
TABLE 62.	INDEX-07H: EQ BAND-2 GAIN (BP2: HO)	59
TABLE 63.	INDEX-08H: EQ BAND-3 COEFFICIENT (BP3: A1)	60
TABLE 64.	INDEX-09H: EQ BAND-3 COEFFICIENT (BP3: A2)	60
TABLE 65.	INDEX-0AH: EQ BAND-3 GAIN (BP3: HO)	60
TABLE 66.	INDEX-0BH: EQ BAND-4 COEFFICIENT (HPF: A1)	60
TABLE 67.	INDEX-0CH: EQ BAND-4 GAIN (HPF: HO)	60
TABLE 68.	INDEX-10H: EQ CONTROL AND STATUS REGISTER	61
TABLE 69.	INDEX-11H: EQ INPUT VOLUME CONTROL	61
TABLE 70.	INDEX-12H: EQ OUTPUT VOLUME CONTROL	61
TABLE 71.	INDEX-20H: AUTO VOLUME CONTROL REGISTER 0	62
TABLE 72.	INDEX-21H: AUTO VOLUME CONTROL REGISTER 1	62
TABLE 73.	INDEX-22H: AUTO VOLUME CONTROL REGISTER 2	62
TABLE 74.	INDEX-23H: AUTO VOLUME CONTROL REGISTER 3	63
TABLE 75.	INDEX-24H: AUTO VOLUME CONTROL REGISTER 4	63
TABLE 76.	INDEX-25H: AUTO VOLUME CONTROL REGISTER 5	63
TABLE 77.	INDEX-39H: DIGITAL INTERNAL REGISTER	63
TABLE 78.	INDEX-4AH: CLASS D TEMPERATURE SENSOR	64
TABLE 79.	INDEX-54H: AD_DA_MIXER_INTERNAL REGISTER	64
TABLE 80.	REG-74H: TOUCH PANEL CONTROL BYTE 1	65
TABLE 81.	REG-76H: TOUCH PANEL CONTROL BYTE 2	66
TABLE 82.	REG-78H: TOUCH PANEL INDICATION	67
TABLE 83.	REG-7CH: VENDOR ID 1	67
TABLE 84.	REG-7EH: VENDOR ID 2	67
TABLE 85.	ABSOLUTE MAXIMUM RATINGS	68
TABLE 86.	RECOMMENDED OPERATING CONDITIONS	68
TABLE 87.	STATIC CHARACTERISTICS	68
TABLE 88.	ANALOG PERFORMANCE CHARACTERISTICS	69
TABLE 89.	COLD RESET TIMING PARAMETERS	72
TABLE 90.	WARM RESET TIMING PARAMETERS	72
TABLE 91.	AC-LINK CLOCK PARAMETERS	73
TABLE 92.	AC-LINK DATA TIMING PARAMETERS	73
TABLE 93.	AC-LINK SIGNAL RISE AND FALL TIMING PARAMETERS	74
TABLE 94.	AC-LINK LOW POWER MODE TIMING PARAMETERS	75
TABLE 95.	AC-LINK IO PIN CAPACITANCE PARAMETERS	75
TABLE 96.	ORDERING INFORMATION	81

List of Figures

FIGURE 1.	BLOCK DIAGRAM	4
FIGURE 2.	AUDIO MIXER PATH	5
FIGURE 3.	PIN ASSIGNMENTS	6
FIGURE 4.	AC-LINK WAKE UP TIMING	13
FIGURE 5.	DEFAULT ALC5610 SLOT ARRANGEMENT – CODEC ID ALWAYS 00	14
FIGURE 6.	CONTROLLER AND CODEC CONNECTION	14
FIGURE 7.	PCM MONO DATA MODE A FORMAT (BCLK_POLARITY=0).....	15
FIGURE 8.	PCM MONO DATA MODE A FORMAT (BCLK_POLARITY=1).....	15
FIGURE 9.	PCM MONO DATA MODE B FORMAT (BCLK_POLARITY=0)	16
FIGURE 10.	PCM STEREO DATA MODE A FORMAT (BCLK_POLARITY=0).....	16
FIGURE 11.	PCM STEREO DATA MODE B FORMAT (BCLK_POLARITY=0).....	16
FIGURE 12.	I ² S DATA FORMAT (BCLK_POLARITY=0).....	17
FIGURE 13.	LEFT-JUSTIFIED DATA FORMAT (BCLK_POLARITY=0).....	17
FIGURE 14.	RIGHT-JUSTIFIED DATA FORMAT (BCLK_POLARITY=0).....	17
FIGURE 15.	I ² S SIGNAL LINK SLAVE MODE DIAGRAM (ALC5610 IS SLAVE).....	18
FIGURE 16.	I ² S SIGNAL LINK MASTER MODE DIAGRAM (ALC5610 IS MASTER)	18
FIGURE 17.	4-WIRE RESISTIVE TOUCH PANEL CIRCUIT	26
FIGURE 18.	AUTO VOLUME CONTROL BLOCK DIAGRAM	27
FIGURE 19.	EXAMPLE OF ALC5610 POWER-DOWN/POWER-UP FLOW	29
FIGURE 20.	GPIO IMPLEMENTATION.....	30
FIGURE 21.	POWER CONTROL TO MIC INPUT	44
FIGURE 22.	GPIO AND IRQ LOGIC	50
FIGURE 23.	JACK-INSERT-DETECT PULL-UP RESISTOR IMPLEMENTED VIA AN EXTERNAL CIRCUIT	53
FIGURE 24.	COLD RESET TIMING	72
FIGURE 25.	WARM RESET TIMING.....	72
FIGURE 26.	DATA OUTPUT AND INPUT TIMING.....	73
FIGURE 27.	SIGNAL RISE AND FALL TIMING.....	74
FIGURE 28.	AC-LINK LOW POWER MODE TIMING.....	75

1. General Description

The ALC5610 is a highly-integrated dual AC'97/PCM interface audio codec with multiple input/output ports and a 4-wire touch panel controller. The ALC5610 is designed for mobile computing and communications.

Stereo audio is supported via the AC'97 interface, and voice functions via a PCM/I²S interface. To reduce component count, the device can connect directly to:

- A 4-wire touch panel
- MONO or stereo differential analog inputs
- Stereo headphone
- Single-end or BTL MONO output
- MONO or Stereo Bridge-Tied Load (BTL) speaker

Multiple analog input and output pins are provided for seamless integration with analog connected wireless communication devices. Differential input/output connections efficiently reduce noise interference, providing better sound quality. Class-AB or Class-D amplifiers are easily swapped via simple register configuration, and the 1 Watt speaker removes the need for an additional amplifier, further cutting both cost and required board area. Additionally, a flexible hardware 5-band equalizer with configurable gain, bandwidth, and center frequency, and enriches the sound experience.

ALC5610 Digital power operates at supply voltages from 1.8V to 3.6V. Analog power operates from 2.3V to 3.6V, and Speaker power operates from 2.3V to 5V. To extend battery life, each section of the device can be powered down individually under software control. Leakage current in maximum power saving state is less than 10 μ A.

The ALC5610 is available in a 7x7mm 'Green' QFN package, making it ideal for use in handheld portable systems.

2. Features

- Single-chip AC'97 Rev 2.2 compatible codec
 - ◆ 16-bit stereo DAC SNR 90dB, THD+N -85dB
 - ◆ 16-bit stereo ADC SNR 85dB, THD+N -80dB
 - ◆ Supports PCM/I2S input and output interface
 - ◆ Supports all WinCE variable rates (8kHz, 11.025kHz, 16kHz, 22.05kHz, 24kHz, 32kHz, 44.1kHz, 48kHz)
- One analog stereo input (LINE-IN)
- One analog MONO single-ended or differential input (PHONE and PHONEN input)
- Stereo, single-ended MONO, or differential analog microphone inputs, with boost pre-amplifiers (+20/+30/+40dB)
- BTL (Bridge-Tied Load) Max. output with on-chip 1W speaker driver (SPKVDD=5V, 8Ω load)
- Stereo headphone output with on-chip 45mW headphone driver (HPVDD=3.3V, 16Ω load)
- 25mW SE or 75mW BTL MONO output support (AVDD=3.3V, 32Ω load)
- Microphone switch detection
- Integrated 16-bit I²S/PCM interface voice DAC for blue-tooth and other external devices
- Power management and enhanced power saving
- Supports digital 5 band equalizer (EQ)
- Supports digital spatial sound and pseudo stereo effect
- Supports pop noise suppression
- Internal PLL can receive wide range of clock input (Digital IO power > 1.8V)
- Digital power supplies from 1.8V to 3.6V, speaker amplifier power supplies from 2.3V to 5V
- Analog power, headphone power, and touch panel power supplies from 2.3V to 3.6V

- Resistive touch panel interface
 - ◆ Supports 4-wire panel
 - ◆ X, Y axis and pressure measurement
 - ◆ 12-bit resolution AUX_ADC for battery measurement, $DNL < \pm 1$ LSB, $INL < \pm 2$ LSBs
 - ◆ Supports pen-down detection in power down mode
- 48-pin QFN package

3. System Applications

- Tablet PC system/Ultra-Mobile PC (UMPC)
- GPS/Personal Navigation Device (PND) or Multi-Media phone
- PDA Phone/Smartphone
- Personal Media Player (PMP)

4. Function Block Diagram

4.1. Function Block

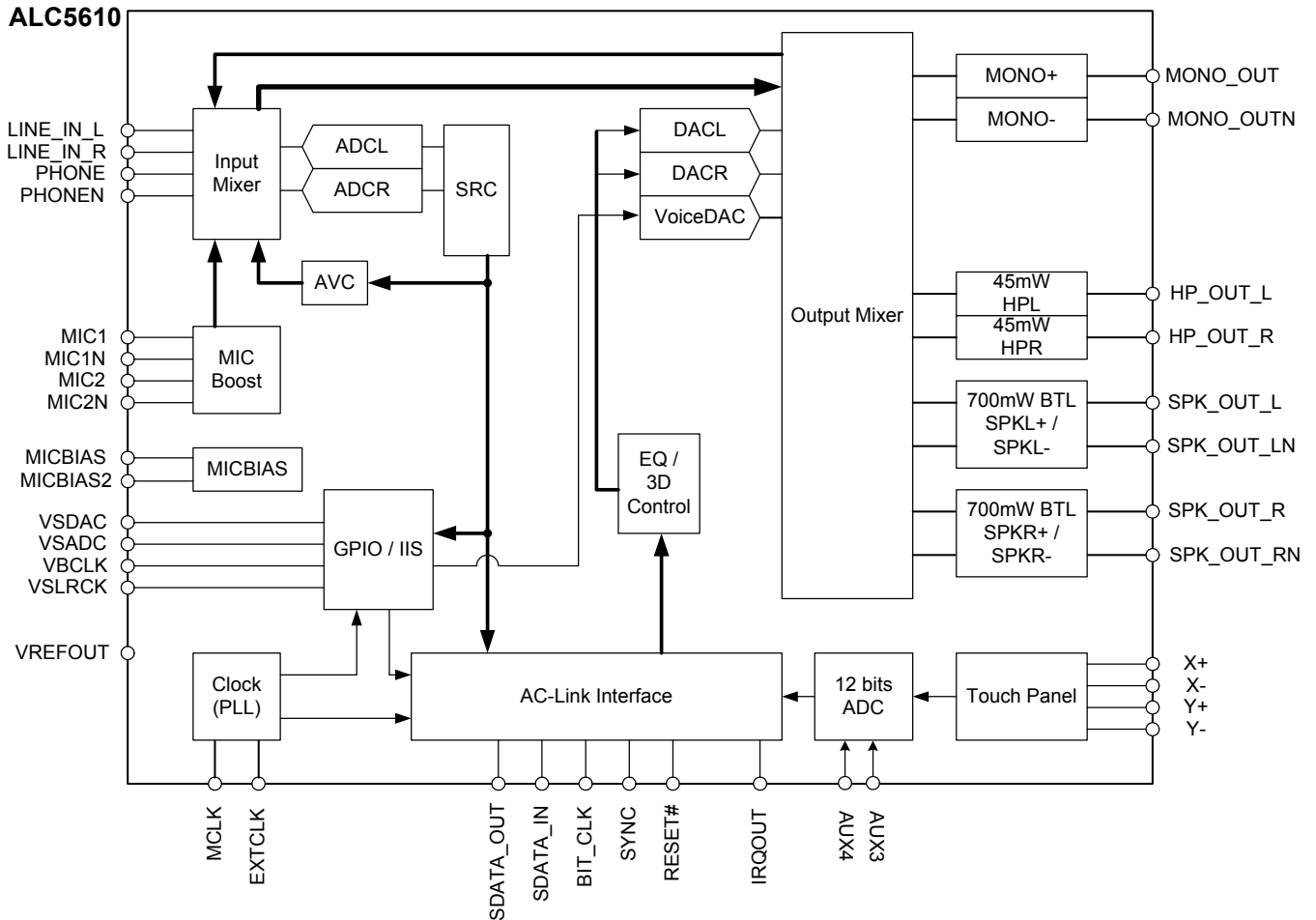

Figure 1. Block Diagram

4.2. Audio Mixer Path

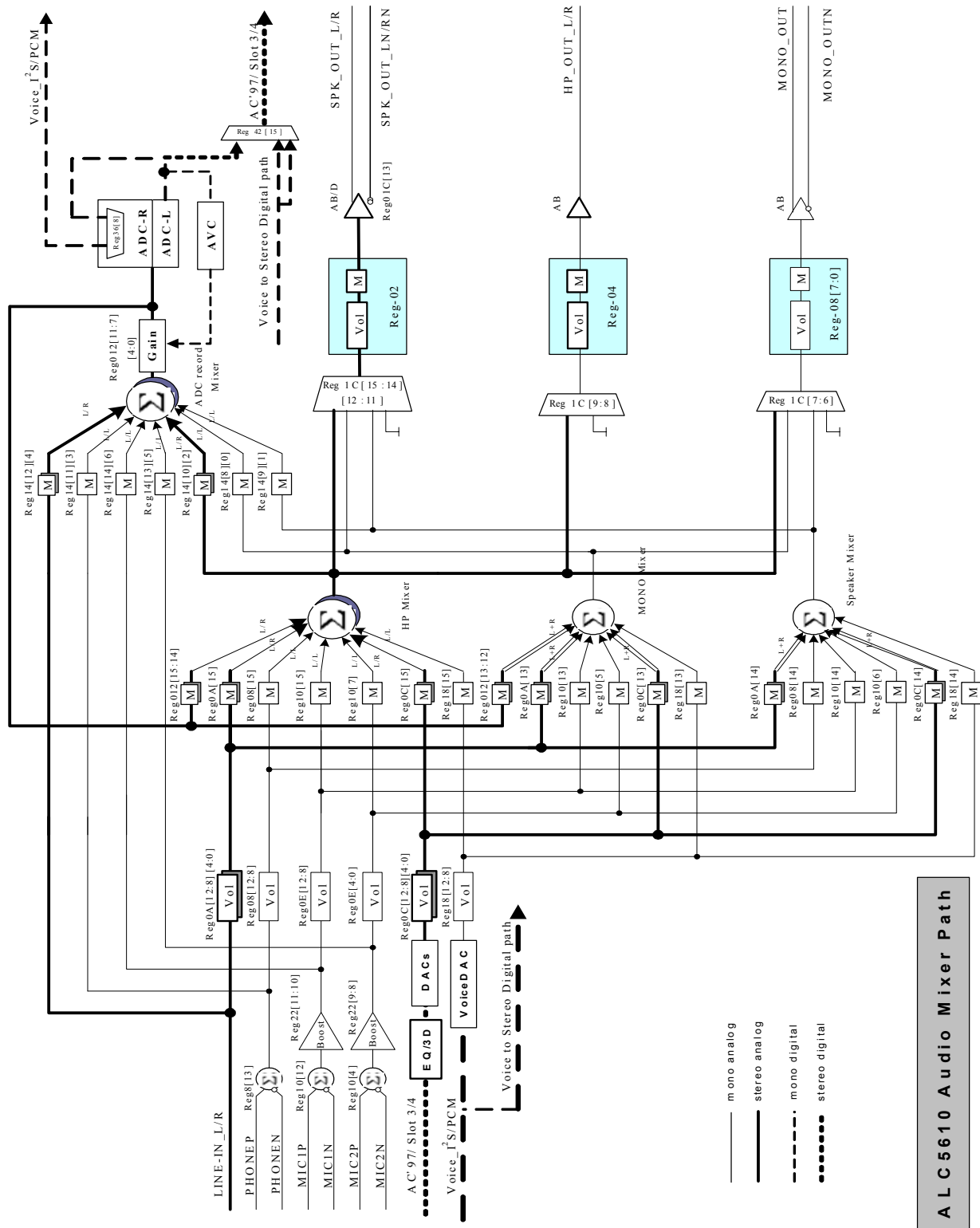

Figure 2. Audio Mixer Path

5. Pin Assignments

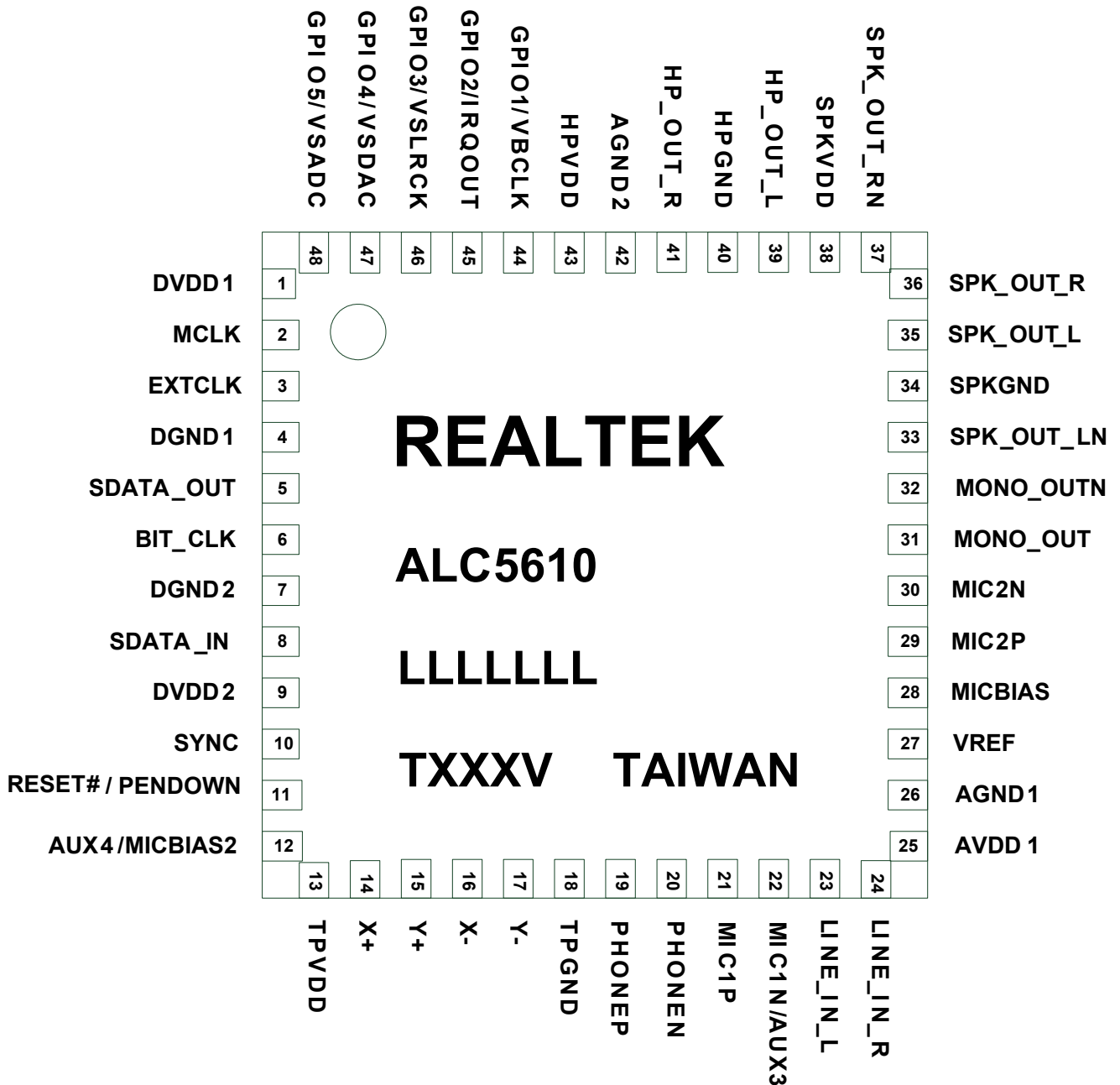

Figure 3. Pin Assignments

5.1. Green Package and Version Identification

Green package is indicated by a ‘G’ in the location marked ‘T’ in Figure 3. The version number is shown in the location marked ‘V’.

6. Pin Descriptions

6.1. AC'97 Digital I/O Pins

Table 1. AC'97 Digital I/O Pins

Name	Type	Pin	Description	Characteristic Definition
MCLK	I	2	Master Clock Input	Schmitt trigger
EXTCLK	IO	3	External Reference Clock Input/Output	Output: $V_{OL}=0.1*DVDD$, $V_{OH}=0.9*DVDD$ Input: Schmitt trigger
SDATA_OUT	I	5	Serial TDM Data Input	Schmitt trigger
BIT_CLK	O	6	Bit Clock Output	$V_{OL}=0.1*DVDD$, $V_{OH}=0.9*DVDD$
SDATA_IN	O	8	Serial TDM Data Output	$V_{OL}=0.1*DVDD$, $V_{OH}=0.9*DVDD$
SYNC	I	10	48kHz Synchronous Input Signal	Schmitt trigger
RESET#/ PENDOWN	I/ O	11	H/W Reset Input Pen-Down Output	Schmitt trigger
GPIO1/VBCLK	IO	44	General Purpose Input and Output 1 / I ² S interface Clock	GPIO: Input/Output VBCLK: Slave input/Master output
GPIO2/IRQOUT	IO	45	General Purpose Input and Output 2 / Interrupt Output	GPIO: Input/Output IRQOUT: Output
GPIO3/VSLRCK	IO	46	General Purpose Input and Output 3 / I ² S Interface Frame Signal	GPIO: Input/Output VSLRCK: Slave input/Master output
GPIO4/VSDAC	IO	47	General Purpose Input and Output 4 / I ² S Interface Serial Data Input	GPIO: Input/Output VSDAC: Schmitt trigger input
GPIO5/VSADC	IO	48	General Purpose Input and Output 5 / I ² S Interface Serial Data Output	GPIO: Input/Output VSADC: Voice data output
				Total: 12 Pins

6.2. Analog I/O Pins

Table 2. Analog I/O Pins

Name	Type	Pin	Description	Characteristic Definition
AUX4/MICBIAS2	IO	12	Auxiliary Input 4/ MIC BIAS Voltage Output 2	Analog input (1Vrms) / Programmable Analog DC Output with 3mA drive
X+	IO	14	Touch Panel Connect Input/Output	X+ for 4-wire panel
Y+	IO	15	Touch Panel Connect Input/Output	Y+ for 4-wire panel
X-	IO	16	Touch Panel Connect Input/Output	X- for 4-wire panel
Y-	IO	17	Touch Panel Connect Input/Output	Y- for 4-wire panel
PHONEP	I	19	Phone Positive Input	Analog Input (1Vrms)
PHONEN	I	20	Phone Negative Input	Analog Input (1Vrms)
MIC1P	I	21	First Mic Positive Input	Analog Input (1Vrms)
MIC1N/AUX3	I	22	First Mic Negative Input / Auxiliary Input 3	Analog Input (1Vrms)
MIC2P	I	29	Second Mic Positive Input	Analog Input (1Vrms)
MIC2N	I	30	Second Mic Negative Input	Analog Input (1Vrms)
LINE_IN_L	I	23	Line Input Left Channel	Analog Input (1Vrms)
LINE_IN_R	I	24	Line Input Right Channel	Analog Input (1Vrms)
MONO_OUT	O	31	Positive MONO Output	Analog Output (1vrms)
MONO_OUTN	O	32	Negative MONO Output	Analog Output (1vrms)
HP_OUT_L	O	39	Headphone Output Left Channel	Analog Output (1Vrms)
HP_OUT_R	O	41	Headphone Output Right Channel	Analog Output (1Vrms)
SPK_OUT_L	O	35	Speaker Output Left Channel	Analog Output (1.3Vrms, SPKVDD = 4.2V)
SPK_OUT_LN	O	33	Negative Speaker Output Left Channel	Analog Output (1.3Vrms, SPKVDD = 4.2V)
SPK_OUT_R	O	36	Speaker Output Right Channel	Analog Output (1.3Vrms, SPKVDD = 4.2V)
SPK_OUT_RN	O	37	Negative Speaker Output Right Channel	Analog Output (1.3Vrms, SPKVDD = 4.2V)
				Total: 21 Pins

6.3. Filter/Reference

Table 3. Filter/Reference

Name	Type	Pin	Description	Characteristic Definition
MICBIAS	O	28	MIC BIAS Voltage Output	Programmable Analog DC Output with 3mA drive
VREF	O	27	Internal Reference Voltage	1 μ f capacitor to analog ground
				Total: 2 Pins

6.4. Power/Ground

Table 4. Power/Ground

Name	Type	Pin	Description	Characteristic Definition
DVDD1	P	1	Digital VDD	1.8V~3.6V (IO)
DGND1	P	4	Digital GND	-
DGND2	P	7	Digital GND	-
DVDD2	P	9	Digital VDD	1.8V~3.6V (Core)
TPVDD	P	13	Analog VDD for Touch Panel	2.3V~3.6V
TPGND	P	18	Analog GND for Touch Panel	-
AVDD1	P	25	Analog VDD	2.3V~3.6V
AGND1	P	26	Analog GND	-
SPKGND	P	34	Analog GND for Speaker Amps	-
SPKVDD	P	38	Analog VDD for Speaker Amps	3.0V~5V (for Ohm loading) 2.3V~5V (for kOhm loading)
HPGND	P	40	Analog GND for Headphone Amps	-
AGND2	P	42	Analog GND	-
HPVDD	P	43	Analog VDD for Headphone Amps	2.3V~3.6V
LFGND	P	49	Thermal Pad, Connect to SPKGND	-
				Total: 14 Pins

Note: $DVDD1 \geq DVDD2$, $SPKVDD \geq AVDD1$, $HPVDD \geq AVDD1 \geq DVDD2$, $TPVDD \geq DVDD2$.

Note: SPDVDD connect 10 μ F Capacitor to SPKVDD is required.

7. Functional Description

7.1. Power

The ALC5610 has many power blocks. SPKVDD operates between 2.3V and 5V. HPVDD, TPVDD and AVDD1 operate between 2.3V and 3.6V. DVDD1 and DVDD2 operate between 1.8V and 3.6V. The power supplier limit conditions are $DVDD1 \geq DVDD2$, $SPKVDD \geq AVDD1$, $HPVDD \geq AVDD1 \geq DVDD2$, $TPVDD \geq DVDD2$, and $AVDD1 = TPVDD$

Table 5. Power Setting for Best Performance

Power Setting	DVDD1	DVDD2	HPVDD	TPVDD	AVDD1	SPKVDD
	3.3V	1.8V	3.3V	3.3V	3.3V	4.2V

7.2. Reset

There are 4 types of reset operation: Power-On Reset (POR), Cold, Warm, and Register reset.

Table 6. Reset Operation

Reset Type	Trigger Condition	CODEC Response
POR	Power-On Reset. Monitor digital power supply voltage reaches V_{POR}	Resets all hardware logic and all registers to default values.
Cold Reset	Asserts RESET# for a specified period	Resets all hardware logic and all registers to default values except some PLL related control registers and logic.
Register Reset	Write Reg-00h	Resets all registers to default values except some PLL related control registers and logic.
Warm Reset	Drives SYNC high for specified period without BIT_CLK	Reactivates AC-Link. No change to register values.

7.2.1. Power-On Reset (POR)

When powered on, DVDD2 passes through the V_{POR} band of the ALC5610 ($V_{POR_ON} \sim V_{POR_OFF}$). A Power-On Reset (POR) will generate an internal reset signal (POR reset 'LOW') to reset the whole chip.

Table 7. Power-On Reset Voltage

Symbol	Min	Typical	Max	Unit
V_{POR_ON}	1.0	-	1.6	V
V_{POR_OFF}	-	1.3	-	V

Note: V_{POR_OFF} must be below V_{POR_ON} .

7.3. Clocking

The Stereo_SYSCLK can be selected from MCLK or PLL. This means MCLK is always provided externally, and the driver should arrange the clock of each block and setup each divider.

The voice codec clock can be selected from MCLK (Master mode), PLL (Master mode), EXTCLK (Slave mode) or VBCLK (Slave mode). The driver should arrange the clock of each block and setup each divider.

In master mode of voice I²S/PCM, EXTCLK can be output by setting Extclk_dir=1. The output frequency will be determined by MCLK and the setting of Extclk_out_sel.

7.3.1. Phase-Locked Loop

A Phase-Locked Loop (PLL) is used to provide a flexible input clock from 2.048MHz to 40MHz. Typical choices are 2.048MHz, 4.096MHz, and 13MHz. The source of the PLL can be set to MCLK or MCLK/2 by setting PLL_pre_div.

The ALC5610 SYSCLK frequency is 24.576MHz. If the system cannot provide 24.576MHz to the ALC5610, the PLL of the ALC5610 can be used to generate a frequency near 24.576MHz. As the PLL parameter is configured through the AC link, the input clock to the MCLK pin must be between 2.048MHz and 80MHz. After the AC link is connected, the driver must configure the PLL in order to output a frequency close to the SYSCLK (24.576MHz). The accuracy of audio output frequency will depend on the accuracy of PLL output.

The PLL transmit formula is:

$$F_{OUT} = (MCLK * (N+2)) / ((M+2) * (K+2)) \text{ \{Typical K=2\}}$$

Table 8. AC-Link Clock Setting Table (Unit: MHz)

MCLK	N	M	F _{VCO}	K	F _{OUT}
13	66	7	98.222	2	24.555
3.6864	78	1	98.304	2	24.576
2.048	94	0	98.304	2	24.576
4.096	70	1	98.304	2	24.576

After a Cold Reset, PLL related Registers are reset to default values, however, they are not reset to default values after a soft-reset (write Reg00). Firmware should not power down the PLL when the PLL output is used as Stereo_SYSCLK.

Note: The ALC5610 will only be enabled after an AC-Link Warm Reset.

7.3.2. AC'97 Mode

For the AC-Link controller, the BIT_CLK driven by PLL will only be enabled after a warm reset.

The sampling rate of the stereo ADC and stereo DAC can be configured separately and is controlled by Reg2C (stereo DAC) and Reg32 (stereo ADC).

7.3.3. Voice I²S/PCM Interface

The ALC5610 supports an independent digital interface for Voice Audio. The voice audio digital interface is used to input digital data to the voice DAC, or output digital data from the voice ADC. The Voice Audio Digital Interface can be configured to Master mode or Slave mode. Whether in Master mode or Slave mode, the sample rate of the Voice ADC and Voice DAC is set via Reg64 and Reg66.

In Master mode, the main clock of the Voice I²S/PCM interface can be input selected from MCLK (with or without a PLL) or EXTCLK. VBCLK and VSLRCK will be configured as output. DRIVER has to set each divider (Reg64 & Reg66) to arrange the clock distribution. See section 12 Appendix A: Voice PCM Interface, page 78 for details.

In Slave mode, the main clock of the Voice I²S/PCM can be input from MCLK or EXTCLK. VBCLK is synchronized externally. VBCLK and VSLRCK will be configured as input. The driver has to set each divider (Reg64 and Reg66) to arrange the clock distribution (see section 12.2 Slave Mode: (voice_port_sel=1), page 80, for more information.

If VBCLK provides 64Fs, 128Fs, or 256Fs externally, the ALC5610 can use VBCLK input as the main clock of the Voice I²S/PCM. See section 12 Appendix A: Voice PCM Interface, page 78 for details.

7.3.4. Voice ADC

The ALC5610 supports Voice ADC for transmitting voice data to a Bluetooth device. The Voice ADC is implemented by sharing from the Right Channel of the Stereo ADC (by setting voice_adc_enable).

When voice_adc_enable=0, the L/R channel stereo ADC sample rate is set according to the stereo sample rate (ADC_SAMPLE_RATE) and output to slots 3 & 4 of the AC'97 interface.

When voice_adc_enable=1, the sample rate of the Left channel is set by the stereo sample rate (ADC_SAMPLE_RATE). The sample rate of the Right channel is set by the voice sample rate (Reg64 & Reg66). The Left channel ADC data is output to the Left (slot 3) and duplicated to the Right (slot 4) of the AC'97 interface. The Right channel of the Stereo ADC data is then used as a Voice ADC and output to voice I²S/PCM.

7.4. Digital Data Interface

7.4.1. AC-Link

When the ALC5610 takes serial data from the AC'97 controller, it samples SDATA_OUT on the falling edge of BIT_CLK. When the ALC5610 sends serial data to the AC'97 controller, it starts to drive SDATA_IN on the rising edge of BIT_CLK.

The ALC5610 will return any uninstalled bit or register read operations with 0. The ALC5610 also stuffs an unimplemented slot or bit with 0 in SDATA-IN. Note that AC-Link is MSB-justified.

See the 'Audio CODEC '97 Component Specification Revision 2.2' for detailed information.

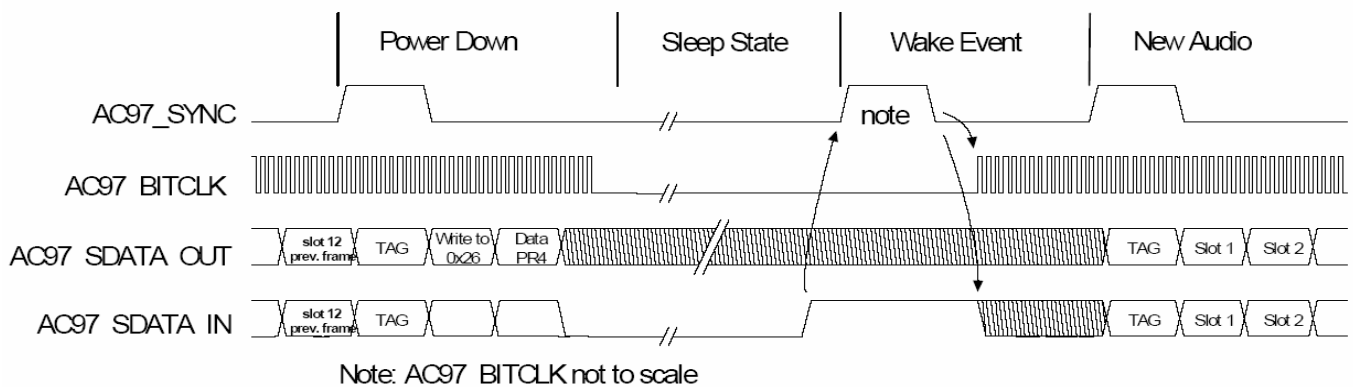

Figure 4. AC-Link Wake Up Timing

If wakeup control (Reg52 & Reg5E[1]) is enabled during Sleep state, the ALC5610 will assert SDATA_IN and IRQOUT when interrupted.

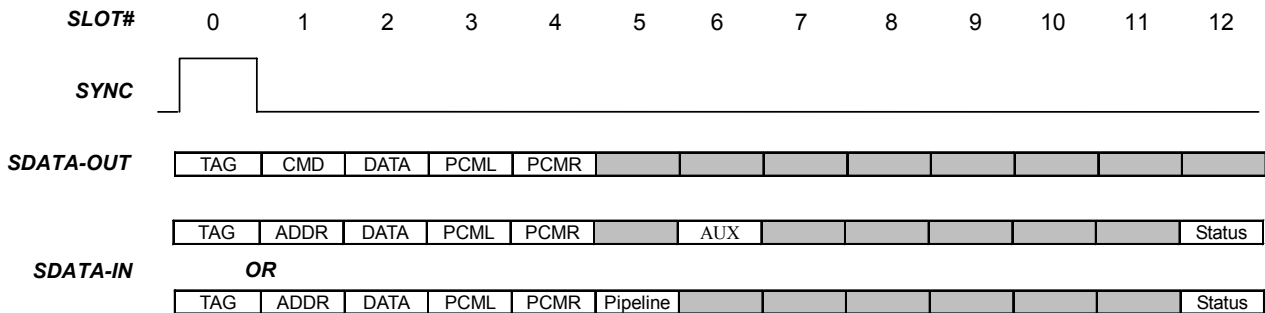

Figure 5. Default ALC5610 Slot Arrangement – CODEC ID Always 00

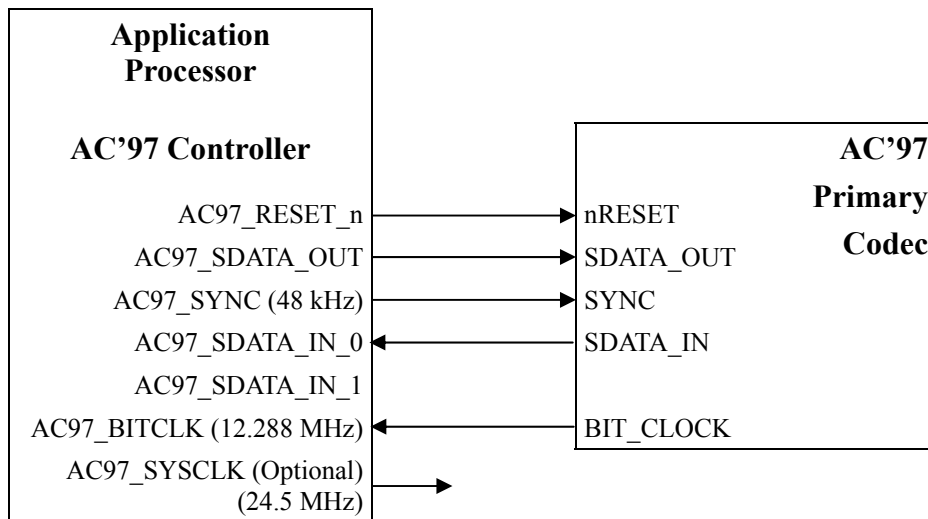

Figure 6. Controller and Codec Connection

7.4.2. Voice I²S/PCM Interface

The voice interface can be configured as Master mode or Slave mode. Four audio data formats are supported:

- PCM mode
- Left justified mode
- Right justified mode
- I²S mode

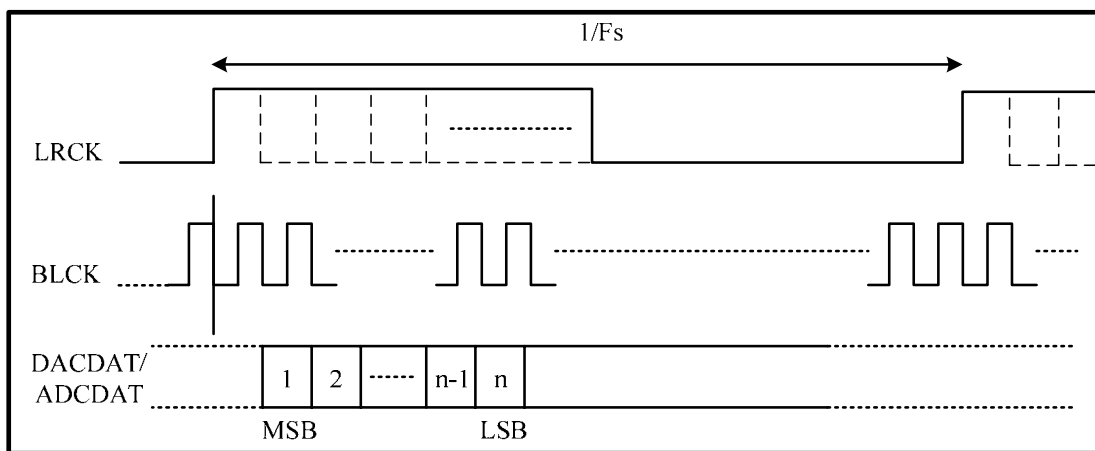

Figure 7. PCM MONO Data Mode A Format (bclk_polarity=0)

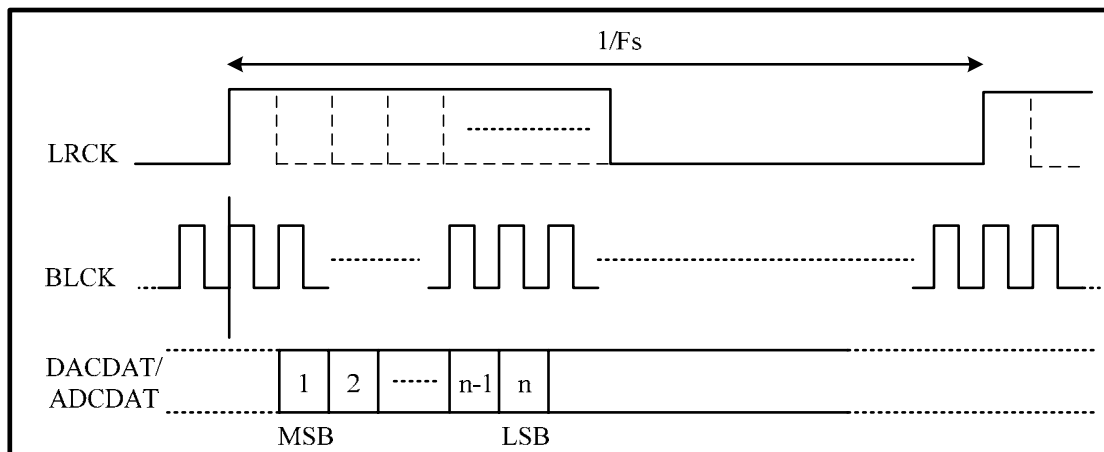

Figure 8. PCM MONO Data Mode A Format (bclk_polarity=1)

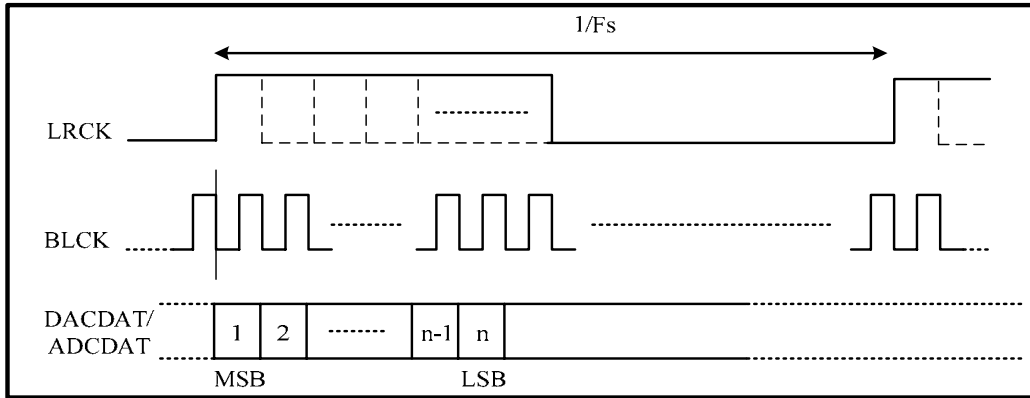

Figure 9. PCM MONO Data Mode B Format (bclk_polarity=0)

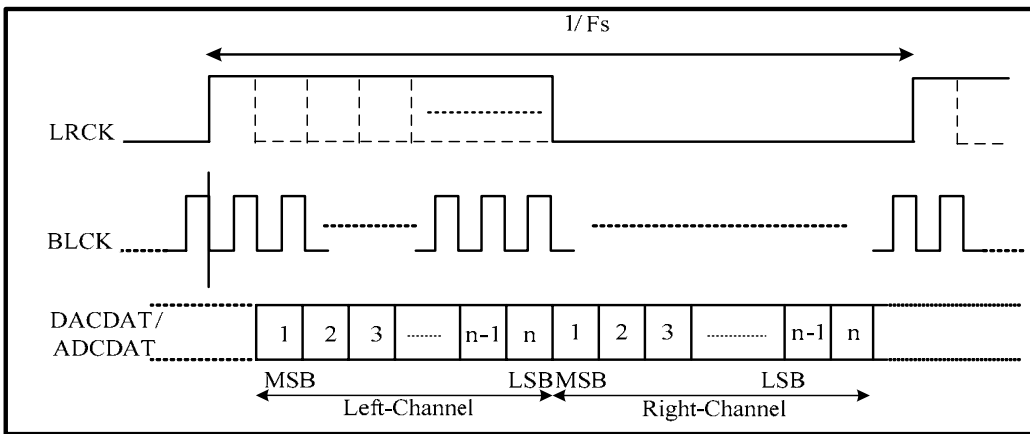

Figure 10. PCM Stereo Data Mode A Format (bclk_polarity=0)

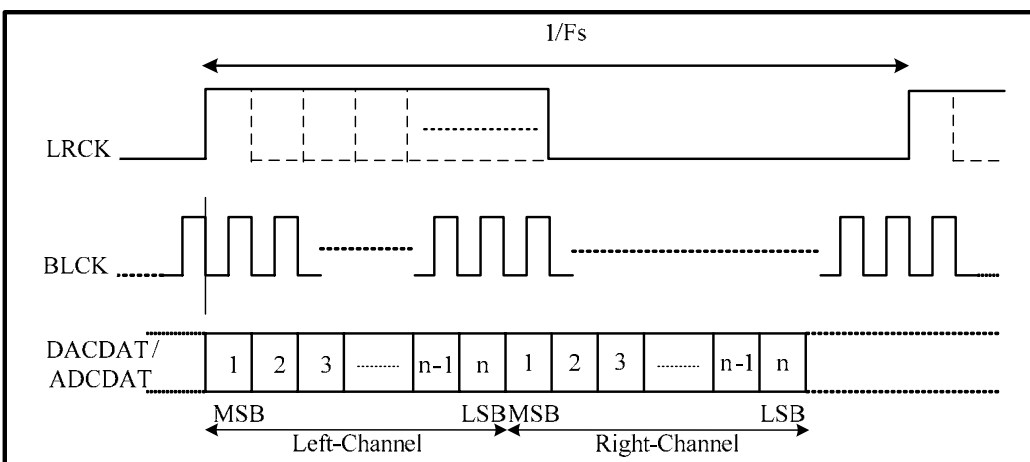

Figure 11. PCM Stereo Data Mode B Format (bclk_polarity=0)

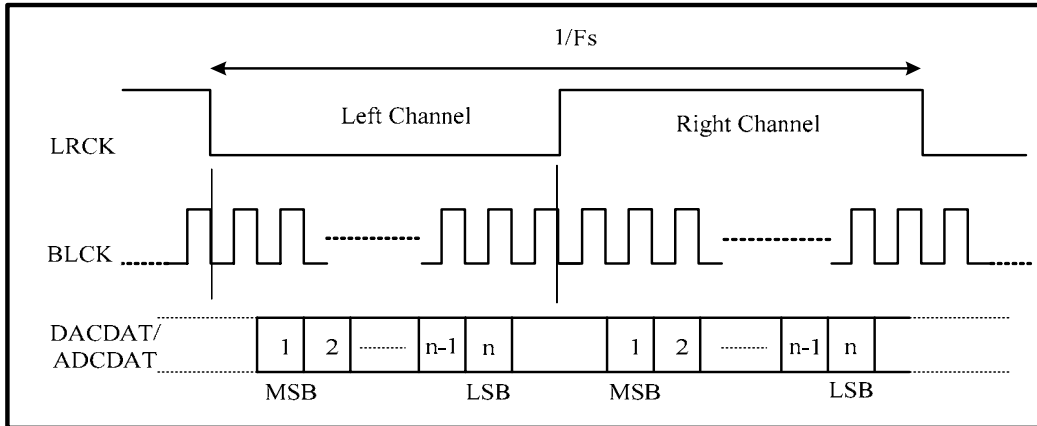

Figure 12. I²S Data Format (bclk_polarity=0)

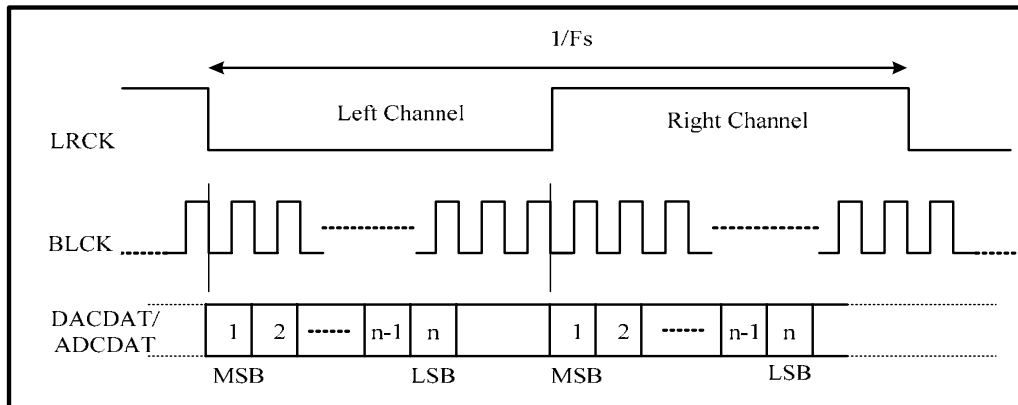

Figure 13. Left-Justified Data Format (bclk_polarity=0)

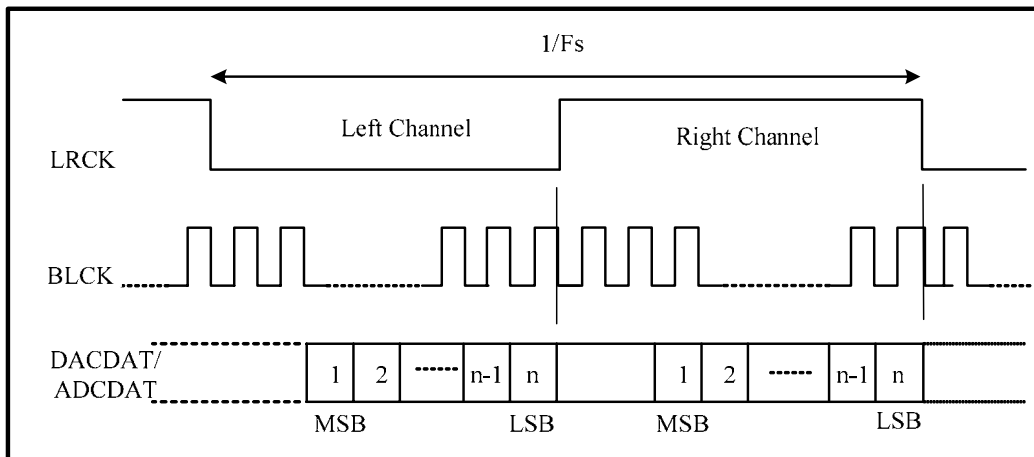

Figure 14. Right-Justified Data Format (bclk_polarity=0)

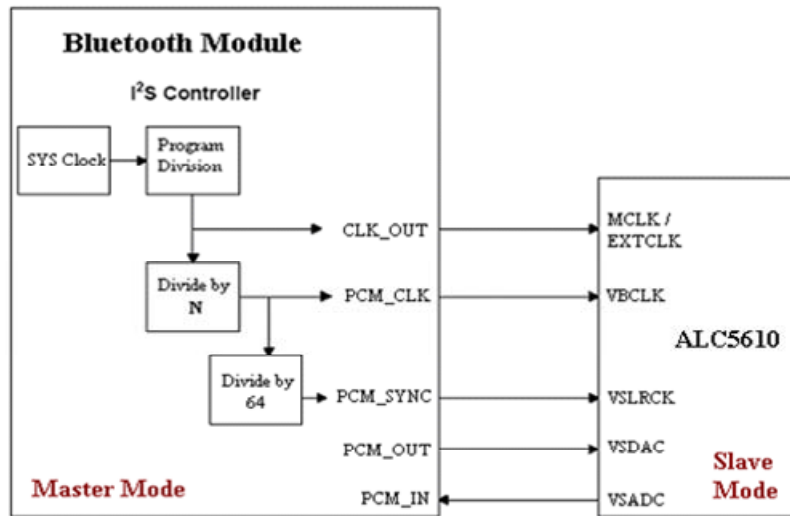

Figure 15. I²S Signal Link Slave Mode Diagram (ALC5610 is Slave)

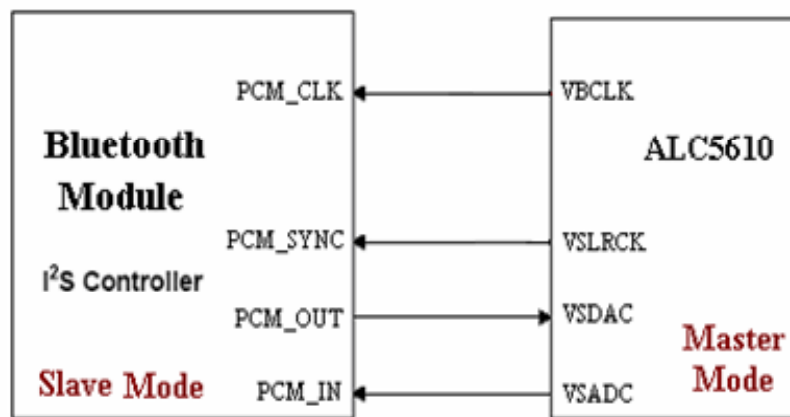

Figure 16. I²S Signal Link Master Mode Diagram (ALC5610 is Master)

Table 9. I²S Signal Link Master Mode Clock Table

SYSCLK	BITCLK	SYNC
12.235MHz	3.058MHz	47.794K (closest std = 48kHz)
11.346MHz	2.836MHz	44.318K (closest std = 44.1kHz)
5.622MHz	1.405MHz	21.953K (closest std = 22.05kHz)
4.105MHz	1.026MHz	16.036K (closest std = 16.00kHz)
2.811MHz	702.75kHz	10.980K (closest std = 11.025kHz)
2.053MHz	513.25kHz	8.0194K (closest std = 8.00kHz)

7.5. Audio Data Path

7.5.1. Stereo ADC and Voice ADC

The stereo ADC is used for recording stereo sound or, by setting `voice_adc_enable`, can be configured to MONO PCM ADC (Left channel of stereo ADC) + voice ADC (Right channel of stereo ADC) when using bluetooth and recording at the same time.

- When `voice_adc_enabl=0`, the sample rate of the stereo ADC can be configured via setting Reg32.
- When `voice_adc_enabl=1`, the sample rate of the voice ADC is set by Reg66, and the sample rate of the MONO PCM ADC is set by Reg32.

The sample rate of the stereo ADC is independent of the stereo DAC sample rate.

In order to save power, the left and right ADC can be powered down separately by setting Reg3C [6], [7]. `PR0=1` will disable both channels of the ADC.

The volume control of the stereo ADC is set via Reg12[11:7][4:0].

7.5.2. Stereo DAC

The sample rate of the stereo DAC is controlled by Reg2C.

Reg0C[12:8][4:0] can be used to control the volume of DAC output.

7.5.3. Voice to Stereo Digital Path

The ALC5610 supports a voice to digital stereo path for voice command through Bluetooth by setting Reg42[15]=1. The Voice data will be transferred from the voice I²S/PCM to the AC'97 directly. This function is only supported when the Voice and Stereo I²S/PCM are in Master Mode. The driver should set the same sample rate between the Voice DAC and the stereo ADC.

When a voice to stereo digital path is enabled, the signal from `Voice_I2S/PCM` is direct output to Left (slot 3) and is duplicated to Right (slot 4) of the AC'97 interface.

The Voice to Stereo Digital Path and Voice ADC functions can exist at the same time.

7.5.4. Voice DAC

The Voice DAC is dedicated to playback of received voice signals from the voice_I2S/PCM interface. Typically, it is used at an 8kHz sample rate.

In Voice I²S/PCM Master mode, the sample rate is set by the VoDAC clock Divider (Reg64). In addition, Reg66[7:4][2:0] is used to set the over-sample rate clock divider of the Voice ADC/DAC filter to 64Fs or 128Fs. Reg66[13] must be set according to the over-sample rate clock.

Performance at 128Fs is better than 64Fs, but with higher power consumption. For best performance, the frequency of the Voice DAC Sigma Delta clock must be equal to, or higher than, the Voice DA filter over-sampling rate. The volume control of the Voice DAC is set via Reg18[12:8].

7.6. Mixers

The ALC5610 supports four mixers for all audio function requirements:

- Headphone mixer for 2 channels
- MONO mixer
- Speaker mixer
- ADC record mixer

7.6.1. Headphone Mixer

The headphone mixer is used to drive stereo output, including HP_OUT_L/R, SPK_OUT_L/R (SPK_OUT_LN/RN) and MONO_OUT (MONO_OUTN). The output of the headphone mixer can be input to the ADC record mixer.

The following signals can be mixed into the headphone mixer:

- LINE-IN_L/R (Controlled by Reg0A)
- PHONEP/N (Controlled by Reg08)
- MIC1P/N and MIC2P/N (Controlled by Reg22 & Reg10)
- Stereo DAC output (Controlled by Reg0C)
- Voice DAC output (Controlled by Reg18)
- ADC record mixer output (Controlled by Reg12 & Reg14).

Note: The headphone mixer can be powered down by setting Reg3C[5][4].

7.6.2. MONO Mixer

The MONO mixer is used to drive MONO_OUT (MONO_OUTN) and SPK_OUT_L/R (SPK_OUT_LN/RN). The output of the MONO mixer can be input to the ADC record mixer. The output of the MONO mixer is two channels with the same signal.

The following signals can be mixed into the MONO mixer:

- LINE-IN_L/R (Controlled by Reg0A)
- MIC1P/N and MIC2P/N (Controlled by Reg22 & Reg10)
- Stereo DAC output (Controlled by Reg0C)
- Voice DAC output (Controlled by Reg18)
- ADC record mixer output (Controlled by Reg12 & Reg14).

Note: The MONO mixer can be powered down by setting Reg3C[2].

7.6.3. Speaker Mixer

The speaker mixer is the same as the MONO mixer and is used to drive MONO_OUT (MONO_OUTN) and SPK_OUT_L/R (SPK_OUT_LN/RN). The output of the speaker mixer can be input to the ADC record mixer. The output of the speaker mixer is two channels with the same signal.

The following signals can be mixed into the speaker mixer:

- LINE-IN_L/R (Controlled by Reg0A)
- PHONEP/N (Controlled by Reg08)
- MIC1P/N and MIC2P/N (Controlled by Reg22 & Reg10)
- Stereo DAC output (Controlled by Reg0C)
- Voice DAC output (Controlled by Reg18)

Note: The speaker mixer can be powered down by setting Reg3C[3].

7.6.4. ADC Record Mixer

The ADC record mixer is used to mix analog signals as input to the Stereo ADC for recording. Output of the ADC record mixer can be input to the headphone mixer, MONO mixer, and speaker mixer.

The following signals can be mixed into the ADC record mixer:

- LINE-IN_L/R (Controlled by Reg0A)
- PHONEP/N (Controlled by Reg08)
- MIC1P/N and MIC2P/N (Controlled by Reg22 & Reg10)
- Headphone mixer output
- MONO mixer output
- Speaker mixer output

Note: The ADC record mixer can be powered down by setting Reg3C[1][0].

7.7. Analog Audio Input Path

The ALC5610 supports four Analog Audio Input paths:

- Line_IN_L/R
- PHONEP/N
- MIC1
- MIC2

7.7.1. Line Input

Line_In_L and Line_In_R provide 2-channel stereo single-ended input that can be mixed into the MONO mixer, Headphone mixer, Speaker mixer, or the ADC record mixer.

The Line_In_L/R volume and mute are controlled by Reg0A. Reg3E[7:6] can be used to power down Line_In volume control.

7.7.2. Phone Input

PHONEP/N provides one-channel MONO differential or single-ended input configured by Reg08[13] that can be mixed into the ADC record mixer, or any analog output mixer except for the MONO mixer. PHONEP is main input when differential mode is disabled.

The PHONEP/N volume and mute are controlled by Reg08. Reg3E[5:4] can be used to power down the PHONEP/N volume control and mixer.

7.7.3. Microphone Input

MIC1P/N and MIC2P/N provide two-channel stereo differential or single-ended input via Reg10[12], [4], that can be mixed into the ADC record mixer, or any analog output mixer. MIC1P and MIC2P are main inputs when differential mode is disabled. MIC1N is pin-shared to AUX3 input.

The ALC5610 Microphone input boost provides 20/30/40dB boost, set by Reg22[11:10] (for MIC1), and by Reg22[9:8] (for MIC2). The MIC1/2 volume and mute are controlled by Reg0E.

For detailed power management of MIC1/2, Reg3E[3][2] can be used to power down the MIC1/2 volume control. Reg3E[1][0] can be used to power down MIC1/2 and mixer.

7.7.4. MIC1N/AUX3 and MICBIAS2/AUX4 Pin Sharing

MIC1N is pin-shared with AUX3 input of AUX_ADC. MICBIAS2 is pin-shared with AUX4 input of AUX_ADC. The driver must set the related register as shown in Table 10.

Table 10. Pin Sharing Configuration Table

AUX3_mic1n_sharing	AUX4_micbias2_sharing	Reg76[0]: Aux_measure_sel	Reg76[7]: AUX_measure_en	Reg10[12]: mic1_diff_ctrl	Reg3A[2]: pow_mic2_bias
MIC1N	AUX4	AUX4 (0'b)	-	-	Disable (0'b)
MIC1N	MICBIAS2	-	0'b	-	-
AUX3	AUX4	AUX3/AUX4 (1'b/0'b)	-	Disable (0'b)	Disable (0'b)
AUX3	MICBIAS2	AUX3 (1'b)	-	Disable (0'b)	-

7.8. Analog Audio Output Data Path

The ALC5610 supports three Analog Audio output paths:

- SPK_OUT_L/R
- HP_OUT_L/R
- MONO_OUT

7.8.1. Speaker Output

SPK_OUT_L/R provides two-channel differential output.

The SPK_OUT_L source is set in Reg1C[15:14]. Sources are shown below:

- Vmid
- Headphone left mixer
- Speaker mixer
- MONO mixer

The SPK_OUT_R source is set in Reg1C[12:11]. Sources are shown below:

- Vmid
- Headphone right mixer
- Speaker mixer
- MONO mixer

The ALC5610 speaker supports Class AB and Class D type amplifiers (set in Reg1C[13]:spk_out_sel). As the voltage of SPKVDD is usually higher than AVDD, the driver should set the Class AB Vmid ratio in Reg40[5:3], and the Class D Vmid ratio in Reg40[7:6] in order to extend the output level.

In class AB mode, for L+R MONO speaker solutions, SPK_OUT_R can select a different signal source (SPKR Volume output or SPKL Volume output by Reg1C[14]) but SPK_OUT_RN only outputs SPKR Volume Negative Output.

The SPK_OUT_L/R volume and mute are controlled by Reg02. Reg3E[13:12] and Reg3E[9:8] can be used to power down SPK output. Reg3C[14]: pow_clsab is used to power down Class AB output.

SPK_OUT_L/R supports the zero-cross detect function (enabled at Reg02[6][14]: sp_l_dezero/sp_r_dezero).

7.8.2. Headphone Output

HP_OUT_L/R provides two-channel single-ended output. The HP_OUT_L/R source is set in Reg1C[9][8]. Sources are shown below:

- Vmid
- Headphone mixer

The HP_OUT_L/R volume and mute are controlled by Reg04.

Reg3E[11]: pow_hp_l_vol and Reg3E[10]: pow_hp_r_vol can be used to power down the volume of HP output.

HP_OUT supports the zero-cross detect function (enabled at Reg04[14][6]:hp_l_dezero/ hp_r_dezero).

7.8.3. MONO Output

MONO_OUT provide one-channel differential or single-ended output configured by Reg08[15]. The MONO_OUT source is set in Reg1C[7:6]. Sources are shown below:

- Vmid
- Headphone mixer (L+R)
- Speaker mixer
- MONO mixer

The MONO_OUT volume and mute are controlled by Reg08.

Reg3E[14]: pow_MONO_out_vol can be used to power down the volume of MONO_OUT.

MONO_OUT supports the zero-cross detect function (enabled at Reg08[6]:MONO_dezero).

7.9. Touch Panel Control

The ALC5610 provides 4-wire resistive touch panel control. X-position, Y-position, Pen-down detection, touch pressure, and AUX measurement are supported by using AUX_ADC.

There are 2 modes within the touch panel measurement: Continuous mode (Reg76[14]=1), and polling mode (Reg76[14]=0).

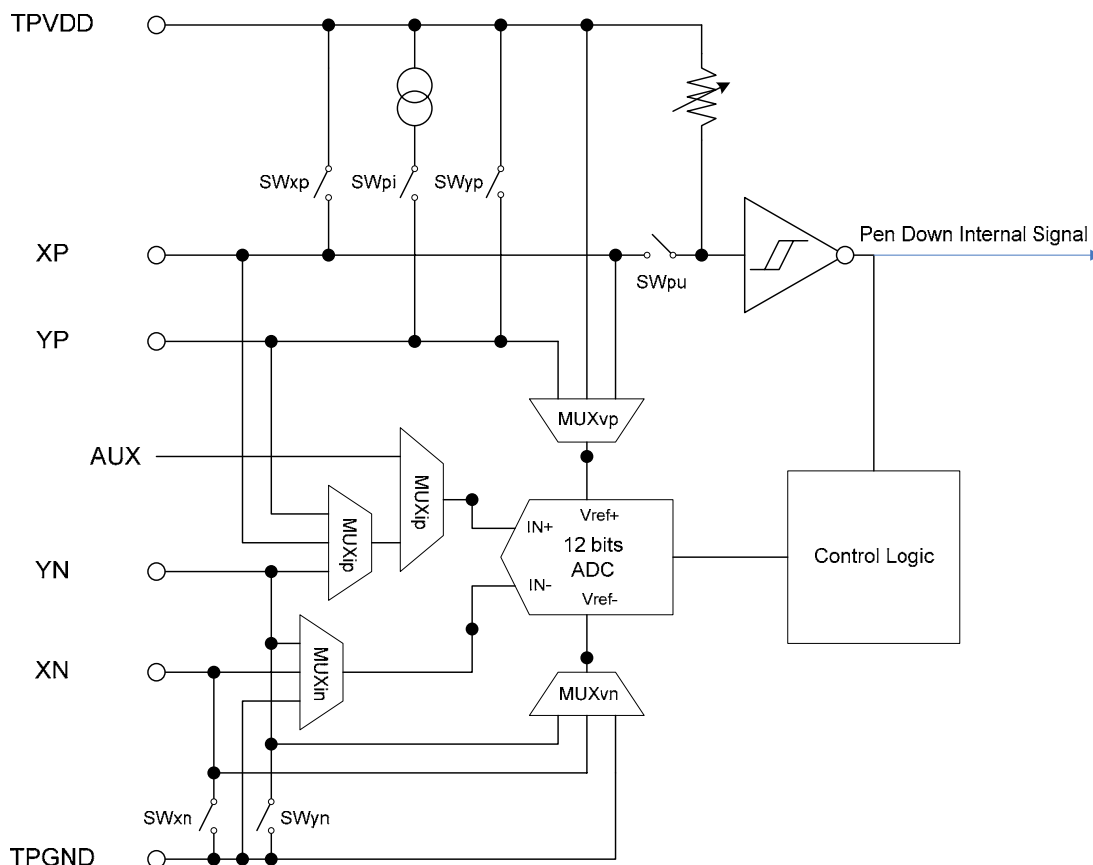

Figure 17. 4-Wire Resistive Touch Panel Circuit

Continuous Mode

The ALC5610 automatically initializes the measurement at the rate set in Reg74[1:0], and sends the measured data back to the AC'97 Controller. It is strongly recommended that the total measure time of one measure cycle (Delay time + measure time) not be longer than the measurement frame period (1/measurement rate).

Polling Mode

In polling mode the AC'97 Controller starts each measurement by setting the measure item and writing Reg76[15]=1. The ALC5610 will clear the Reg76[15] after measurement is complete.

7.10. AVC Control

The Automatic Volume Control (AVC) function dynamically adjusts the input signal quantized by the ADC to an expected sound level by setting THmax and THmin.

When the average level of input signal is higher than THmax, the AVC will decrease the selected analog gain to attenuate the quantized Pulse Code Modulation (PCM) signal to a lower amplitude than THmax.

When the average level of input signal is lower than THmin, the AVC will increase the selected analog gain to amplify the input signal. The quantized Pulse Code Modulation (PCM) signal is then set higher than THmin. The quantized PCM has an average level between THmin and THmax.

The AVC reference source channel and target channel can be individually set by Index20[0] and Reg5E[13:12].

The AVC architecture is shown in Figure 18 below:

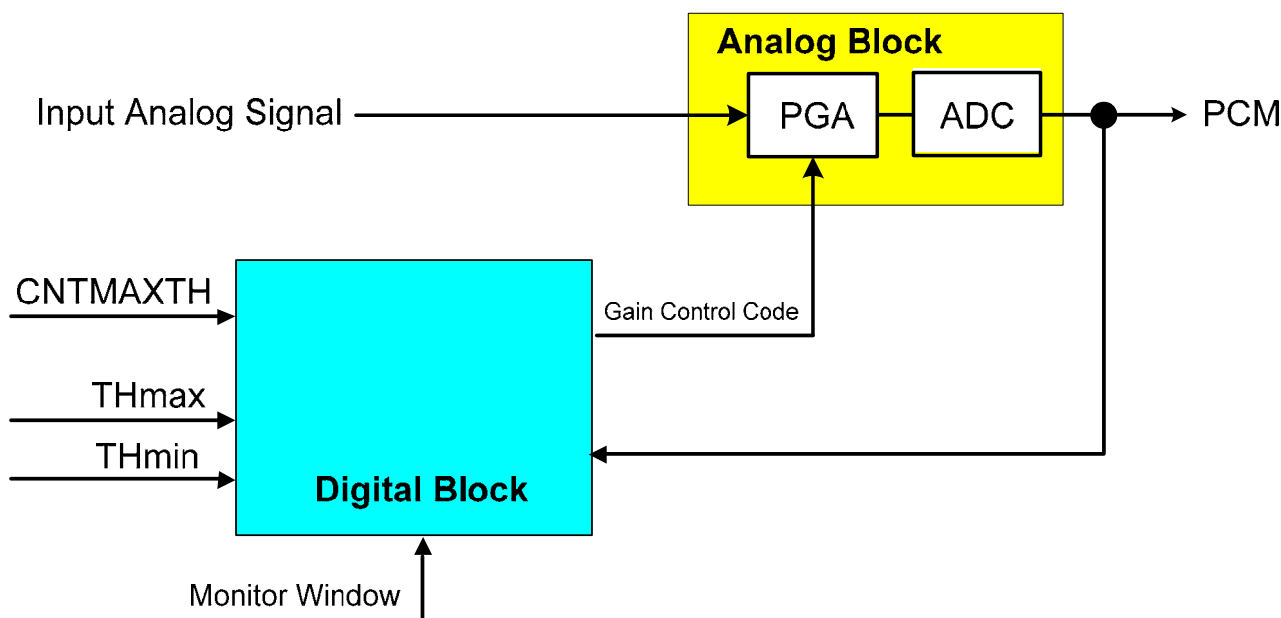

Figure 18. Auto Volume Control Block Diagram

7.11. Hardware Sound Effects

The Sound Effect block is composed of Pseudo Stereo, Spatial 3D and Equalizer blocks. The Pseudo Stereo block is used to convert a MONO source into virtualized stereo output. The Spatial 3D block is a surround sound generator with adjustable amplitude (Gain) and surround depth (Ratio). The Equalizer block can be used to compensate for speaker response, or to make environment sound effects, e.g., ‘Pub’, ‘Live’, ‘Rock’,... etc..

7.11.1. Equalizer Block

The Equalizer block cascades 5 bands of equalizer to compensate for speaker response and to emulate environment sound. One high-pass filter cascaded in the front end is used to drop low frequency tone, which has a larger amplitude and may damage a mini speaker.

The high-pass filter can also be used to adjust Treble strength with gain control. A low-pass filter with gain control can adjust the Bass strength. Three bands of bi-quad bandpass filters are used to emulate environment sounds.

To avoid PCM sample saturation, the digital volume control has up to 18dB of attenuation before the equalizer. A 0~+18dB digital gain after the equalizer is used to correct PCM output to a suitable level.

7.11.2. Pseudo Stereo and Spatial 3D Sound

There are two spatial effects in post-processing; the Pseudo-Stereo Effect + Spatial Effect, and the Stereo Expansion Effect. The Pseudo-Stereo Effect + Spatial Effect converts a MONO signal to a stereo signal by changing the phase and amplitude of the original signal followed by enhancing the spatial effect. The Stereo Expansion Effect enhances the spatial effect when the input signal is Stereo.

7.12. Odd-Addressed Register Access

The ALC5610 will return ‘0000h’ when odd-addressed and unimplemented registers are read.

7.13. Power Management

The ALC5610 supports a standard power down control register as defined in AC'97 (Reg26). More detailed Power Management control is supported in Reg 3C & 3E. Each particular block will only be active when both Reg26 and Reg3C/3E are set to 'Enable'.

7.13.1. Sleep Mode

When PR4 (Reg26) is set, the ALC5610 will enter Sleep Mode. Before entering sleep mode, the driver can set other control bits to save power according to system requirements.

The following functions should be kept operating during sleep mode:

- Pen-down Detection
- GPIO and Interrupts
- Analog to analog path when control registers Reg 3C & 3E are enabled

There are two methods to wake the ALC5610 from Sleep mode

- Warm Reset and Cold Reset from AC Link
- Wake-up from GPIO (configured as Input) and Internal event signal (pen-down, over-temperature) when the wake-up bit is set at Reg52.

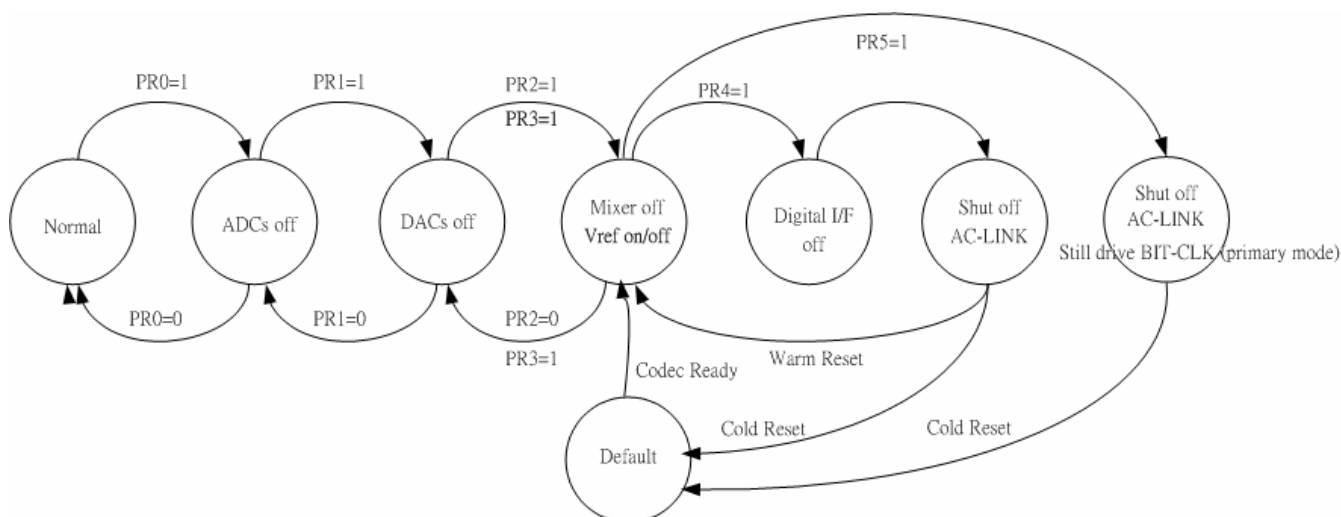

Figure 19. Example of ALC5610 Power-Down/Power-Up Flow

7.14. GPIO and Interrupt

The ALC5610 supports up to five GPIOs. Each GPIO can be configured as Input/Output by Reg4C. When GPIOs are configured as Input, the status will be indicated in Reg54 and Slot 12. When GPIOs are configured as Output, Reg5C is used to drive GPIOs to High (1b) or Low (0b). The status can be read in Reg54.

Interrupt request (IRQ) function can be configured as:

- Sticky by setting Reg50
- Changed polarity by setting Reg4E
- Wake-up by setting Reg52

The wake-up function will drive SDATA_In 'high' when the AC-Link is in sleep mode, and set GPIO_INT (Slot12 bit0) when the AC-Link is awake. The wake up function can only be enabled when Wake-up control (Reg5E[1])=1. The driver can write each bit of Reg54=1 to clear each IRQ status flag.

When VoPCM_En (Reg36[15])=1, GPIOs 1, 3, 4, and 5 will be dedicated as VoDAC_I2S/PCM interface, regardless of GPIO Pin Configure (Reg4C[5:3,1]). These pin cannot be used as GPIOs in this case.

GPIO pin2 can be configured and pin-shared with IRQ_Output by setting Reg56.

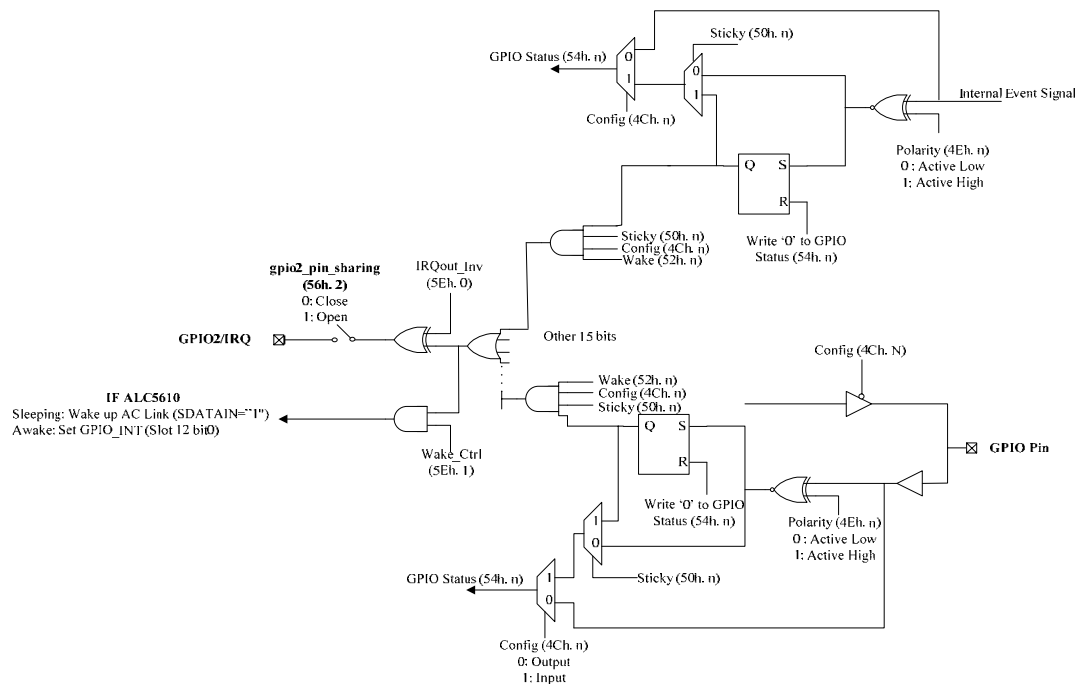

Figure 20. GPIO Implementation

There are some internal events (pen-down, over-temperature, MICBIAS short detect) where GPIOs can be an interrupt source. GPIO Internal event application is located in Reg4C, Reg4E, Reg50, Reg52, and Reg54.

8. Mixer Registers List

Accessing odd numbered registers, or reading unimplemented registers, will return a 0.

8.1. Reg-00h: Reset

Default: 59B4h

Table 11. Reg-00h: Reset

Name	Bits	Read/Write	Reset State	Description
Reserved	15	R	0'h	Reserved. Read as 0
REG-00_b14_b10	14:10	R	16'h	SE[4:0]=10110b
REG-00_b9	9	R	0'h	No Support for 20-Bit ADC
REG-00_b8	8	R	1'h	Supports 16-Bit ADC
REG-00_b7	7	R	1'h	Supports 16-Bit DAC
REG-00_b6	6	R	0'h	No Support for 18-Bit DAC
REG-00_b5	5	R	1'h	Support for Loudness
REG-00_b4	4	R	1'h	Headphone Output Support
Reserved	3	R	0'h	Reserved
REG-00_b2	2	R	1'h	Supports EQ Control
Reserved	1	R	0'h	Reserved. Read as 0
REG-00_b0	0	R	0'h	Dedicated MIC PCM input is not supported. Can be for touch panel ADC use

Note: Writes to this register will reset all registers to their default values except PLL related Register. The written data will be ignored

8.2. Reg-02h: Speaker Output Volume

Default: 8080h

Table 12. Reg-02h: Speaker Output Volume

Name	Bits	Read/Write	Reset State	Description
sp_l_mute	15	RW	1'h	Mute Left Control 0: On 1: Mute Left Channel (-∞dB)
sp_l_dezero	14	RW	0'h	Left Zero-Cross Detector Control 0: Disable 1: Enable
Reserved	13	R	0'h	Reserved. Read as 0
sp_l_vol	12:8	RW	0'h	Speaker Output Left Volume (SPKL[4:0]) in 1.5dB Steps
sp_r_mute	7	RW	1'h	Mute Right Control 0: On 1: Mute Right Channel (-∞dB)
sp_r_dezero	6	RW	0'h	Right Zero-Cross Detector Control 0: Disable 1: Enable
Reserved	5	R	0'h	Reserved. Read as 0
sp_r_vol	4:0	RW	0'h	Speaker Output Right Volume (SPKR[4:0]) in 1.5dB Steps

Note: For SPKR/SPKL, 00h: 0dB attenuation 1Fh: 46.5dB attenuation

8.3. Reg-04h: Headphone Output Volume

Default: 8080h

Table 13. Reg-04h: Headphone Output Volume

Name	Bits	Read/Write	Reset State	Description
hp_l_mute	15	RW	1'h	Mute Left Control 0: On 1: Mute Left Channel (-∞dB)
hp_l_dezero	14	RW	0'h	Left Zero-Cross Detector Control 0: Disable 1: Enable
Reserved	13	R	0'h	Reserved. Read as 0
hp_l_vol	12:8	RW	0'h	Headphone Output Left Volume (HPL[4:0]) in 1.5dB Steps
hp_r_mute	7	RW	1'h	Mute Right Control 0: On 1: Mute Right Channel (-∞dB)
hp_r_dezero	6	RW	0'h	Right Zero-Cross Detector Control 0: Disable 1: Enable
Reserved	5	R	0'h	Reserved. Read as 0
hp_r_vol	4:0	RW	0'h	Headphone Output Right Volume (HPR[4:0]) in 1.5dB Steps

Note: For HPR/HPL, 00h: 0dB attenuation

1Fh: 46.5dB attenuation

8.4. Reg-08h: Phone Input/MONO Output Volume

Default: C880h

Table 14. Reg-08h: Phone Input/MONO Output Volume

Name	Bits	Read/Write	Reset State	Description
phone2hp_mute	15	RW	1'h	Mute Phone Input to Headphone Mixer Control 0: On 1: Mute (-∞dB)
phone2spk_mute	14	RW	1'h	Mute Phone Input to Speaker Mixer Control 0: On 1: Mute (-∞dB)
phone_diff_ctrl	13	RW	0'h	Phone Differential Input Control 0: Disable 1: Enable
phone_vol	12:8	RW	8'h	Phone Input Volume (PV[4:0]) in 1.5dB Steps (not to ADC)
MONO_mute	7	RW	1'h	Mute MONO Output Control 0: On 1: Mute (-∞dB)
MONO_dezero	6	RW	0'h	Zero-Cross Detector Control 0: Disable 1: Enable
MONO_diff_ctrl	5	RW	0'h	MONO Output Differential Control 0: Disable (SE) 1: Enable (BTL)
MONO_vol	4:0	RW	0'h	MONO Output Master Volume (MOV[4:0]) in 1.5dB Steps

Note: For MOV, 00h: 0dB attenuation

1Fh: 46.5dB attenuation

For PV, 00h: +12dB gain

08h: 0dB attenuation

1Fh: 34.5dB attenuation

8.5. Reg-0Ah: LINE_IN Volume

Default: E808h

Table 15. Reg-0Ah: LINE_IN Volume

Name	Bits	Read/Write	Reset State	Description
li2hp_mute	15	RW	1'h	Mute Volume Output to Headphone Mixer Control 0: On 1: Mute
li2spk_mute	14	RW	1'h	Mute Volume Output to Speaker Mixer Control 0: On 1: Mute
li2MONO_mute	13	RW	1'h	Mute Volume Output to MONO Mixer Control 0: On 1: Mute
li_l_vol	12:8	RW	08'h	LINE_IN Left Volume (NLV[4:0]) in 1.5dB Steps
Reserved	7:5	R	0'h	Reserved
li_r_vol	4:0	RW	8'h	LINE_IN Right Volume (NRV[4:0]) in 1.5dB Steps

Note: For NRV/NLV, 00h: +12dB gain 08h: 0dB attenuation 1Fh: 34.5dB attenuation

8.6. Reg-0Ch: STEREO DAC Volume

Default: E808h

Table 16. Reg-0Ch: STEREO DAC Volume

Name	Bits	Read/Write	Reset State	Description
dac2hp_mute	15	RW	1'h	Mute Volume Output to Headphone Mixer Control 0: On 1: Mute (-∞dB)
dac2spk_mute	14	RW	1'h	Mute Volume Output to Speaker Mixer Control 0: On 1: Mute (-∞dB)
dac2MONO_mute	13	RW	1'h	Mute Volume Output to MONO Mixer Control 0: On 1: Mute (-∞dB)
dac_l_vol	12:8	RW	08'h	PCM Left DAC Volume (PLV[4:0]) in 1.5dB Steps
Reserved	7:5	R	0'h	Reserved
dac_r_vol	4:0	RW	8'h	PCM Right DAC Volume (PRV[4:0]) in 1.5dB Steps

Note: For PRV/PLV, 00h: +12dB gain 08h: 0dB attenuation 1Fh: 34.5dB attenuation

8.7. Reg-0Eh: MIC Volume

Default: 0808h

Table 17. Reg-0Eh: MIC Volume

Name	Bits	Read/Write	Reset State	Description
Reserved	15:13	R	0'h	Reserved
mic1_vol	12:8	RW	08'h	MIC1 Volume (M1V[4:0]) in 1.5dB Steps
Reserved	7:5	R	0'h	Reserved
mic2_vol	4:0	RW	8'h	MIC2 Volume (M2V[4:0]) in 1.5dB Steps

For M2V/M1V, 00h: +12dB gain

08h: 0dB attenuation

1Fh: 34.5dB attenuation

8.8. Reg-10h: MIC Routing Control

Default: E0E0h

Table 18. Reg-10h: MIC Routing Control

Name	Bits	Read/Write	Reset State	Description
mic12hp_mute	15	RW	1'h	Mute MIC1 Volume Output to Headphone Mixer 0: On 1: Mute
mic12spk_mute	14	RW	1'h	Mute MIC1 Volume Output to Speaker Mixer 0: On 1: Mute
mic12MONO_mute	13	RW	1'h	Mute MIC1 Volume Output to MONO Mixer 0: On 1: Mute
mic1_diff_ctrl	12	RW	0'h	MIC1 Differential Input Control 0: Disable 1: Enable
Reserved	11:8	R	0'h	Reserved
mic22hp_mute	7	RW	1'h	Mute MIC2 Volume Output to Headphone Mixer 0: On 1: Mute
mic22spk_mute	6	RW	1'h	Mute MIC2 Volume Output to Speaker Mixer 0: On 1: Mute
mic22MONO_mute	5	RW	1'h	Mute MIC2 Volume Output to MONO Mixer 0: On 1: Mute
mic2_diff_ctrl	4	RW	0'h	MIC2 Differential Input Control 0: Disable 1: Enable
Reserved	3:0	R	0'h	Reserved

8.9. Reg-12h: ADC Record Gain

Default: F58Bh

Table 19. Reg-12h: ADC Record Gain

Name	Bits	Read/Write	Reset State	Description
adc2hp_l_mute	15	RW	1'h	Mute Left Gain Output to Headphone Mixer Control 0: On 1: Mute (-∞dB)
adc2hp_r_mute	14	RW	1'h	Mute Right Gain Output to Headphone Mixer Control 0: On 1: Mute (-∞dB)
adc2MONO_l_mute	13	RW	1'h	Mute Left Gain Output to MONO Mixer Control 0: On 1: Mute (-∞dB)
adc2MONO_r_mute	12	RW	1'h	Mute Right Gain Output to MONO Mixer Control 0: On 1: Mute (-∞dB)
adc_l_vol	11:7	RW	0B'h	ADC Record Gain Left Channel (LRG[4:0]) in 1.5dB Steps 00h: -16.5dB attenuation 0Bh: 0dB gain 1Fh: 30dB gain
adc_l_dezero	6	RW	0'h	ADC_L Zero-Cross Detector Control 0: Disable 1: Enable
adc_r_dezero	5	RW	0'h	ADC_R Zero-Cross Detector Control 0: Disable 1: Enable
adc_r_vol	4:0	RW	0B'h	ADC Record Gain Right Channel (RRG[4:0]) in 1.5dB Steps 00h: -16.5dB attenuation 0Bh: 0dB gain 1Fh: 30dB gain

8.10. Reg-14h: ADC Record Mixer Control

Default: 7F7Fh

Table 20. Reg-14h: ADC Record Mixer Control

Name	Bits	Read/Write	Reset State	Description
Reserved	15	R	0'h	Reserved
adcrec_l_mute	14:8	RW	7F'h	Left Mixer Mute Control 0: On 1: Mute (-∞dB) Bit 14: MIC1 Bit 13: MIC2 Bit 12: LINE_IN_L Bit 11: PHONE Bit 10: Headphone Mixer Left Channel Bit 9: Speaker mixer Bit 8: MONO Mixer
Reserved	7	R	0'h	Reserved
adcrec_r_mute	6:0	RW	7F'h	Right Mixer Mute Control 0: On 1: Mute (-∞dB) Bit 6: MIC1 Bit 5: MIC2 Bit 4: LINE_IN_R Bit 3: PHONE Bit 2: Headphone Mixer Right Channel Bit 1: Speaker mixer Bit 0: MONO Mixer

8.11. Reg-18h: Voice DAC Output Volume

Default: E800h

Table 21. Reg-18h: Voice DAC Output Volume

Name	Bits	Read/Write	Reset State	Description
voice2hp_mute	15	RW	1'h	Mute VoDAC Output to Headphone Mixer Control 0: On 1: Mute (-∞dB)
voice2spk_mute	14	RW	1'h	Mute VoDAC Output to Speaker Mixer Control 0: On 1: Mute (-∞dB)
voice2MONO_mute	13	RW	1'h	Mute VoDAC Output to MONO Mixer Control 0: On 1: Mute (-∞dB)
voice_vol	12:8	RW	8'h	VoDAC Output Volume (VV[4:0]) in 1.5dB Steps
Reserved	7:0	R	0'h	Reserved

Note: For VV, 00h: +12dB gain

08h: 0dB attenuation

1Fh: 34.5dB attenuation

8.12. Reg-1Ch: Output Mixer Control

Default: 0000h

Table 22. Reg-1Ch: Output Mixer Control

Name	Bits	Read/Write	Reset State	Description
spk_l_vol_in_sel	15:14	RW	0'h	SPKL Volume Input Select 00: VMID (No input) 01: HP Left Mixer 10: Speaker Mixer 11: MONO
spk_l_out_sel	13	RW	0'h	SPKL and SPKR Output Select 0: Class AB 1: Class D
spk_r_vol_in_sel	12:11	RW	0'h	SPKR Volume Input Select 00: VMID (No input) 01: HP Right Mixer 10: Speaker Mixer 11: MONO
Reserved	10	R	0'h	Reserved
hp_l_in_sel	9	RW	0'h	HPL Volume Input Select 0: VMID (No input) 1: HP Left Mixer
hp_r_in_sel	8	RW	0'h	HPR Volume Input Select 0: VMID (No input) 1: HP Right Mixer
MONO_in_sel	7:6	RW	0'h	MONO Volume Input Select 00: VMID (No input) 01: HP Left + Right Mixer 10: Speaker Mixer 11: MONO Mixer
Reserved	5	R	0'h	Reserved
clab_amp_source_sel	4	RW	0'h	In Class AB Mode SPK_OUT_R Output Amplifier Source Select 0: SPKR Volume Output 1: SPKL Volume Output Note: SPK_OUT RN: SPKR Volume Negative Output
Reserved	3:0	R	0'h	Reserved

8.13. Reg-22h: Microphone Control

Default: 0000h

Table 23. Reg-22h: Microphone Control

Name	Bits	Read/Write	Reset State	Description
Reserved	15:12	R	0'h	Reserved
mic1_boost_ctrl	11:10	RW	0'h	MIC1 Boost Control 00: Bypass 01: +20dB 10: +30dB 11: +40dB
mic2_boost_ctrl	9:8	RW	0'h	MIC2 Boost Control 00: Bypass 01: +20dB 10: +30dB 11: +40dB
Reserved	7:6	R	0'h	Reserved. Read as 0
mic1_bias_voltage_ctrl	5	RW	0'h	MICBIAS1 Output Voltage Control 0: 0.9 * AVDD 1: 0.75 * AVDD
mic2_bias_voltage_ctrl	4	RW	0'h	MICBIAS2 Output Voltage Control 0: 0.9 * AVDD 1: 0.75 * AVDD
Reserved	2:3	R	0'h	Reserved. Read as 0
mic_bias_threshold	1:0	RW	0'h	MICBIAS1/2 Short Current Detector Threshold 00: 600μA 01: 1200μA 1x: 1800μA

8.14. Reg-26h: Power Down Control/Status

Default: EF00h

Table 24. Reg-26h: Power Down Control/Status

Name	Bits	Read/Write	Reset State	Description
ac_pr7	15	RW	1'h	PR7 0: Normal 1: Power down Speaker Amplifier
ac_pr6	14	RW	1'h	PR6 0: Normal 1: Power down Headphone Out and MONO Out
ac_pr5	13	RW	1'h	PR5 0: Normal 1: Disable internal clock of AC'97 (Without PLL)
ac_pr4	12	RW	0'h	PR4 0: Normal 1: Power down AC-Link <i>Note: Though this bit is read as 1, write 1 to power down the AC-Link</i>

Name	Bits	Read/Write	Reset State	Description
ac_pr3	11	RW	1'h	PR3 0: Normal 1: Power down Mixer (Vref/Vrefout off)
ac_pr2	10	RW	1'h	PR2 0: Normal 1: Power down Mixer (Vref/Vrefout are still on)
ac_pr1	9	RW	1'h	PR1 0: Normal 1: Power down STEREO DAC
ac_pr0	8	RW	1'h	PR0 0: Normal 1: Power down STEREO ADC, and input MUX
Reserved	7:4	R	0'h	Reserved. Read as 0
vref_status	3	R	0'h	Vref Status 1: Vref is up to normal level 0: Not yet up to normal level
analog_mixer_status	2	R	0'h	Analog Mixer Status 1: Ready 0: Not yet ready
dac_status	1	R	0'h	DAC Status 1: Ready 0: Not yet ready (Inverse of PR1)
adc_status	0	R	0'h	ADC Status 1: Ready 0: Not yet ready (Inverse of PR0)

Table 25. Truth Table for Power Down Mode (PD=Power Down)

	ADC	DAC	Mixer	Vref	ACLINK	Int CLK	HP-OUT	MONO-OUT	SPK-OUT
PR0=1	PD	-	-	-	-	-	-	-	-
PR1=1	-	PD	-	-	-	-	-	-	-
PR2=1	-	-	PD	-	-	-	PD	-	-
PR3=1	PD	PD	PD	PD	-	-	PD	-	-
PR4=1	PD	PD	-	-	PD	-	-	-	-
PR5=1	PD	PD	-	-	PD	PD	-	-	-
PR6=1	-	-	-	-	-	-	PD	PD	-
PR7=1	-	-	-	-	-	-	-	-	PD

8.15. Reg-2Ah: Tone Control

Default: 0000h

Table 26. Reg-2Ah: Tone Control

Name	Bits	Read/Write	Reset State	Description
Reserved	15:1	R	0'h	Reserved
ac_src_en	0	RW	0'h	Enable Variable Rate Audio Control 0: Off 1: On

8.16. Reg-2Ch: AC'97 Stereo DAC Rate/DPE Rate

Default: BB80h

Table 27. Reg-2Ch: AC'97 Stereo DAC Rate/DPE Rate

Name	Bits	Read/Write	Reset State	Description
dac_sample_rate	15:0	RW	BB80'h	FOSR[15:0] Output Sampling Rate

The ALC5610 supports the following PC99/PC2001 design guide sampling rates.

Table 28. PC99/PC2001 Design Guide Sampling Rates

Sampling Rate	FOSR[15:0]
8000	1F40h
11025	2B11h
12000	2EE0
16000	3E80h
22050	5622h
24000	5DC0
32000	7D00h
44100	AC44h
48000	BB80h

When ac_src_en=0 (VRA is disabled), any non-zero value in this register will be forced to BB80h.

8.17. Reg-32h: AC'97 Stereo ADC Rate

Default: BB80h

Table 29. Reg-32h: AC'97 Stereo ADC Rate

Name	Bits	Read/Write	Reset State	Description
adc_sample_rate	15:0	RW	BB80'h	IISR[15:0] Output Sampling Rate.

The ALC5610 supports the following PC99/PC2001 design guide sampling rates.

Table 30. PC99/PC2001 Design Guide Sampling Rates

Sampling Rate	IISR[15:0]
8000	1F40h
11025	2B11h
12000	2EE0
16000	3E80h
22050	5622h
24000	5DC0
32000	7D00h
44100	AC44h
48000	BB80h

8.18. Reg-36h: Extend Serial Data Port Control (VoDAC_I2S/PCM)

Default: 0000h

Table 31. Reg-36h: Extend Serial Data Port Control (VoDAC_I2S/PCM)

Name	Bits	Read/Write	Reset State	Description
VoPCM_En	15	RW	0'b	Enable PCM Interface on GPIO1, 3, 4, 5 0: GPIO function 1: VoPCM interface
voice_port_sel	14	RW	0'h	Extend Serial Data Port Mode Selection 0: Master 1: Slave
Reserved	13:9	R	00'h	Reserved
voice_adc_enable	8	RW	0'b	Voice ADC Enable 0b: Disable (ADC_L=ADC_R=Stereo) 1b: Enable (ADC_L=Stereo, ADC_R=Voice)
voice_vbclk_polarity_ctrl	7	RW	0'h	Voice I ² S VBCLK Polarity Control 0: Normal 1: Invert

Name	Bits	Read/Write	Reset State	Description
voice_pcm_mode_sel	6	RW	0'h	PCM Mode Select 0: Mode A 1: Mode B Non PCM Mode Control 0: Normal VSLRCK 1: Invert VSLRCK
Reserved	5:4	R	0'h	Reserved
voice_data_len_sel	3:2	RW	0'h	Data Length Selection 00: 16 bits 01: 20 bits 10: 24 bits 11: 32 bits
voice_data_format_sel	1:0	RW	0'h	Voice Data Format Selection 00: I ² S format 01: Right justified 10: Left justified 11: PCM format

8.19. Reg-3Ah: Power Management Addition 1

Default: 0000h

Table 32. Reg-3Ah: Power Management Addition 1

Name	Bits	Read/Write	Reset State	Description
depop_MONOOutb	15	RW	0'h	Depop of MONO Out 0: Enable (De-pop Enable) 1: Disable (De-pop Disable)
depop_hp_outb	14	RW	0'h	Depop of HP Out 0: Enable (De-pop Enable) 1: Disable (De-pop Disable)
pow_zcd	13	RW	0'h	All Zero-Cross Detect Power down 0: Disable 1: Enable
ip_en	12	RW	0'h	Pressure Measurement Source Current Enable 0: Disable 1: Enable
Pow_zcd_timo_out_en	11	RW	0'h	Zero Cross Time Out Enable 0: Disable 1: Enable
Reserved	10:6	RW	0'h	Reserved
pow_mic1_bias_det_ctrl	5	RW	0'h	MICBIAS1 Short Current Detector Control 0: Disable 1: Enable
pow_mic2_bias_det_ctrl	4	RW	0'h	MICBIAS2 Short Current Detector Control 0: Disable 1: Enable
pow_mic1_bias	3	RW	0'h	0: Disable 1: Enable microphone1 bias
pow_mic2_bias	2	RW	0'h	0: Disable 1: Enable microphone2 bias
pow_main_bias	1	RW	0'h	0: Disable 1: Enable Main bias of the ALC5610
pow_dac_ref	0	RW	0'h	0: Disable 1: Enable ALL DAC reference of the ALC5610

8.20. Reg-3Ch: Power Management Addition 2

Default: 0000h

Table 33. Reg-3Ch: Power Management Addition 2

Name	Bits	Read/Write	Reset State	Description
pow_thermal	15	RW	0'h	Thermal Detect (Temp Sensor) 0: Disable 1: Enable
pow_clsab	14	RW	0'h	Class_AB Power (All) 0: Disable 1: Enable
pow_vref	13	RW	0'h	VREF of All Analog Circuits 0: Disable 1: Enable
pow_pll	12	RW	0'h	PLL 0: Disable 1: Enable PLL
pow_tp_adc	11	RW	0'h	Touch Panel and AUX_ADC 0: Disable 1: Enable
pow_voice_dac	10	RW	0'h	VoDAC Clock 0: Disable 1: Enable <i>Note: Disabled includes Voice I2S interface.</i>
pow_dac_l	9	RW	0'h	Left Stereo DAC Filter Clock 0: Disable 1: Enable
pow_dac_r	8	RW	0'h	Right Stereo DAC Filter Clock 0: Disable 1: Enable
pow_adc_l	7	RW	0'h	Left Stereo ADC Filter Clock and Input Gain 0: Disable 1: Enable
pow_adc_r	6	RW	0'h	Right Stereo ADC Filter Clock and Input Gain 0: Disable 1: Enable
pow_hp_l	5	RW	0'h	Left Headphone Mixer 0: Disable 1: Enable
pow_hp_r	4	RW	0'h	Right Headphone Mixer 0: Disable 1: Enable
pow_spk_mixer	3	RW	0'h	Speaker Mixer 0: Disable 1: Enable
pow_MONO_mixer	2	RW	0'h	MONO Mixer 0: Disable 1: Enable
pow_adc_rec_l_mixer	1	RW	0'h	Left ADC Record Mixer 0: Disable 1: Enable
pow_adc_rec_r_mixer	0	RW	0'h	Right ADC Record Mixer 0: Disable 1: Enable

8.21. Reg-3Eh: Power Management Addition 3

Default: 0000h

Table 34. Reg-3Eh: Power Management Addition 3

Name	Bits	Read/Write	Reset State	Description
Reserved	15	R	0'h	Reserved
pow_MONO_out_vol	14	RW	0'h	MONO_OUT Volume Control (Amp) 0: Disable 1: Enable
pow_spk_outln	13	RW	0'h	SPK_OUTLN Output (Enable Class AB & Class D) 0: Disable 1: Enable
pow_spk_outrn	12	RW	0'h	SPK_OUTRN Output (Enable Class AB & Class D) 0: Disable 1: Enable
pow_hp_l_vol	11	RW	0'h	HP_OUT_L Volume Control (Amp) 0: Disable 1: Enable
pow_hp_r_vol	10	RW	0'h	HP_OUT_R Volume Control (Amp) 0: Disable 1: Enable
pow_spk_l	9	RW	0'h	SPK_OUT_L Output (Enable Class AB & Class D) 0: Disable 1: Enable
pow_spk_r	8	RW	0'h	SPK_OUT_R Output (Enable Class AB & Class D) 0: Disable 1: Enable
pow_li_l_vol	7	RW	0'h	LINE_IN Left Volume Control 0: Disable 1: Enable
pow_li_r_vol	6	RW	0'h	LINE_IN Right Volume Control 0: Disable 1: Enable
pow_phone_vol	5	RW	0'h	PHONE Volume Control 0: Disable 1: Enable
pow_phone_admixer	4	RW	0'h	PHONE AD Mixer 0: Disable 1: Enable
pow_mic1_vol	3	RW	0'h	MIC1 Volume Control 0: Disable 1: Enable
pow_mic2_vol	2	RW	0'h	MIC2 Volume Control 0: Disable 1: Enable
pow_mic1_admixer	1	RW	0'h	MIC1 AD Mixer and Boost 0: Disable 1: Enable
pow_mic2_admixer	0	RW	0'h	MIC2 AD Mixer and Boost 0: Disable 1: Enable

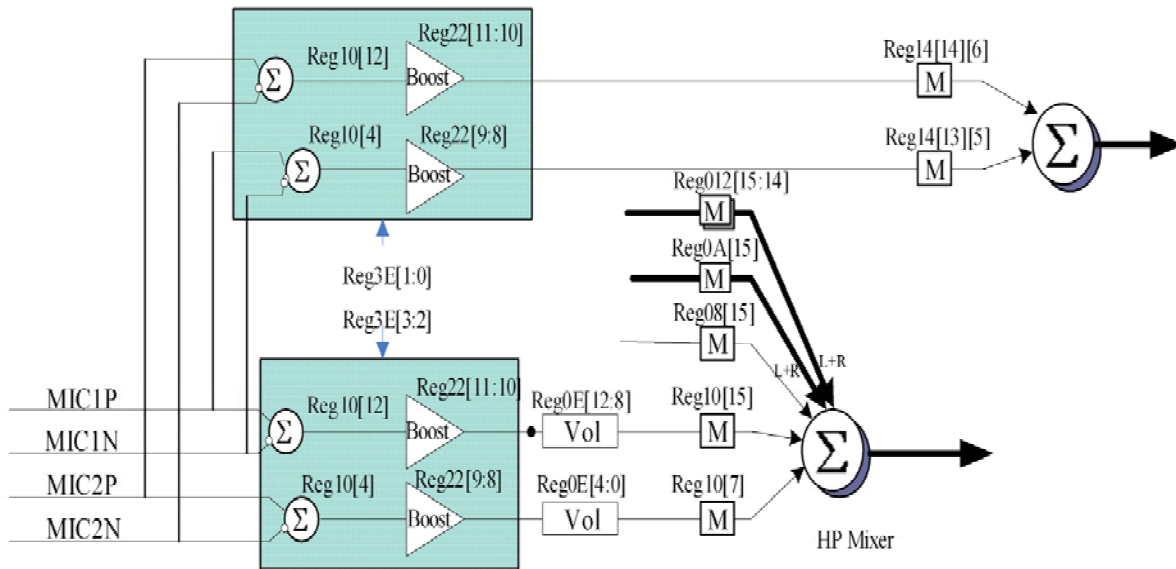

Figure 21. Power Control to MIC Input

8.22. Reg-40h: General Purpose Control Register 1

Default: 0428h

Table 35. Reg-40h: General Purpose Control Register 1

Name	Bits	Read/Write	Reset State	Description
sel_sysclk	15	RW	0'h	Clock Source MUX Control 0: MCLK 1: PLL Output
Extclk_dir	14	RW	0'h	EXTCLK Direction Control 0: Input 1: Output
Reserved	13:10	RW	1'h	Reserved
hp_amp_ctrl	9:8	RW	0'h	Headphone Amplifier V_{MID} Ratio Control (Output Gain Control) 00: 1 01: 1.25 1x: 1.5
spk_ampD_ctrl	7:6	RW	0'h	Speaker Class D Amplifier V_{MID} Ratio Control (Output Gain Control) 00: 1.75 Vdd 01: 1.5 Vdd 10: 1.25 Vdd 11: 1.0 Vdd
spk_ampAB_ctrl	5:3	RW	5'h	Speaker Class AB Amplifier V_{MID} Ratio Control (Output Gain Control) 000: 2.25 Vdd 001: 2.00 Vdd 010: 1.75 Vdd 011: 1.5 Vdd 100: 1.25 Vdd 101: 1 Vdd Others: Not allowed
Reserved	2:0	RW	0'h	Reserved

8.23. Reg-42h: General Purpose Control Register 2

Default: 0000h

Table 36. Reg-42h: General Purpose Control Register 2

Name	Bits	Read/Write	Reset State	Description
voice_stereo_digitalpath_en	15	RW	0'b	Voice to Stereo Digital Path Enable 0b: Disable 1b: Enable
Reserved	14	RW	0'h	Reserved
se_btl_clsab	13	RW	0'b	Single End & BTL of SPK_Class AB Selection 0: Differential Mode 1: Single-End Mode
Reserved	12:1	RW	0'h	Reserved
pll_pre_div	0	RW	0'b	PLL Pre-Divider 0b: ÷1 1b: ÷2

8.24. Reg-44h: PLL Control

Default: 0000h

Table 37. Reg-44h: PLL Control

Name	Bits	Read/Write	Reset State	Description
pll_n_code	15:8	RW	00'h	N[7:0] Code for Analog PLL 00000000: Div 2 00000001: Div 3 11111111: Div 257
pll_m_bypass	7	RW	0'h	Bypass PLL M 0b: No bypass 1b: Bypass
pll_k_code	6:4	RW	0'h	K[2:0] Code for Analog PLL 000: Div 2 001: Div 3 111: Div 9
pll_m_code	3:0	RW	0'h	M[3:0] Code for Analog PLL 0000: Div 2 0001: Div 3 1111: Div 17

Note: The PLL transmit formula is $F_{OUT} = (MCLK * (N+2)) / ((M+2) * (K+2))$ {Typical K=2}

8.24.1. AC-Link PLL Clock Setting Table (Unit: MHz)

Table 38. AC-Link PLL Clock Setting Table (Unit: MHz)

MCLK	N	M	F _{VCO}	K	F _{OUT}
13	66	7	98.222	2	24.555
3.6864	78	1	98.304	2	24.576
2.048	94	0	98.304	2	24.576
4.096	70	1	98.304	2	24.576

Note: PLL will only be enabled after a warm reset of the AC-Link

8.25. Reg-4Ch: GPIO Pin Configuration

Default: 2E3Eh

Table 39. Reg-4Ch: GPIO Pin Configuration

Name	Bits	Read/Write	Reset State	Description
Reserved	15:14	R	00'b	Reserved
pendown_conf	13	RW	1'h	Pen-down Detect Status Source Configuration 0: Bypass 1: Normal
Reserved	12	R	0'b	Reserved
over_temp_conf	11	RW	1'h	Over-temperature Status Source Configuration 0: Bypass 1: Normal
mic1_short_det_conf	10	RW	1'h	MICBIAS1 Short Current Status Source Configuration 0: Bypass 1: Normal
mic2_short_det_conf	9	RW	1'h	MICBIAS2 Short Current Status Source Configuration 0: Bypass 1: Normal
Reserved	8:6	R	0'h	Reserved
gpio5_conf	5	RW	1'h	GPIO5 Pin Configuration 0: Output 1: Input
gpio4_conf	4	RW	1'h	GPIO4 Pin Configuration 0: Output 1: Input
gpio3_conf	3	RW	1'h	GPIO3 Pin Configuration 0: Output 1: Input
gpio2_conf	2	RW	1'h	GPIO2 Pin Configuration 0: Output 1: Input
gpio1_conf	1	RW	1'h	GPIO1 Pin Configuration 0: Output 1: Input
Reserved	0	R	0'h	Reserved. Read as 0

8.26. Reg-4Eh: GPIO Pin Polarity

Default: 2E3Eh

Table 40. Reg-4Eh: GPIO Pin Polarity

Name	Bits	Read/Write	Reset State	Description
Reserved	15:14	R	00'b	Reserved
pendown_polarity	13	RW	1'h	Pen-down Detect Polarity 0: Low Active 1: High Active
Reserved	12	R	0'b	Reserved
over_temp_polarity	11	RW	1'h	Over-temperature Polarity 0: Low Active 1: High Active
mic1_short_det_polarity	10	RW	1'h	MICBIAS1 Short Current Detect Polarity 0: Low Active 1: High Active
mic2_short_det_polarity	9	RW	1'h	MICBIAS2 Short Current Detect Polarity 0: Low Active 1: High Active
Reserved	8:6	R	0'h	Reserved. Read as 0
gpio5_polarity	5	RW	1'h	GPIO Pin Polarity 0: Low Active 1: High Active
gpio4_polarity	4	RW	1'h	GPIO Pin Polarity 0: Low Active 1: High Active
gpio3_polarity	3	RW	1'h	GPIO Pin Polarity 0: Low Active 1: High Active
gpio2_polarity	2	R/W	1'h	GPIO Pin Polarity 0: Low Active 1: High Active
gpio1_polarity	1	R/W	1'h	GPIO Pin Polarity 0: Low Active 1: High Active
Reserved	0	R	0'h	Reserved. Read as 0

8.27. Reg-50h: GPIO Pin Sticky

Default: 0000h

Table 41. Reg-50h: GPIO Pin Sticky

Name	Bits	Read/Write	Reset State	Description
Reserved	15:14	R	00'b	Reserved
pendown_sticky_En	13	RW	0'h	Pen-down Detect Sticky Enable 0: Not sticky 1: Sticky
Reserved	12	R	0'b	Reserved
over_temp_sticky_En	11	RW	0'h	Over-temperature Sticky Enable 0: Not sticky 1: Sticky
mic1_short_det_sticky_En	10	RW	0'h	MICBIAS1 Short Current Detect Sticky Enable 0: Not sticky 1: Sticky

Name	Bits	Read/Write	Reset State	Description
mic2_short_det_sticky_En	9	RW	0'h	MICBIAS2 Short Current Detect Sticky Enable 0: Not sticky 1: Sticky
Reserved	8:6	R	0'h	Reserved. Read as 0
gpio5_sticky_En	5	RW	0'h	GPIO5 Pin Sticky Enable 0: Not sticky 1: Sticky
gpio4_sticky_En	4	RW	0'h	GPIO4 Pin Sticky Enable 0: Not sticky 1: Sticky
gpio3_sticky_En	3	RW	0'h	GPIO3 Pin Sticky Enable 0: Not sticky 1: Sticky
gpio2_sticky_En	2	RW	0'h	GPIO2 Pin Sticky Enable 0: Not sticky 1: Sticky
gpio1_sticky_En	1	RW	0'h	GPIO1 Pin Sticky Enable 0: Not sticky 1: Sticky
Reserved	0	R	0'h	Reserved. Read as 0

8.28. Reg-52h: GPIO Pin Wake-Up

Default: 0000h

Table 42. Reg-52h: GPIO Pin Wake-Up

Name	Bits	Read/Write	Reset State	Description
Reserved	15:14	R	00'b	Reserved
pendown_wakeup_en	13	RW	0'h	Pen-Down Detect Wake-Up Enable 0: No wake-up 1: Wake Up
Reserved	12	R	0'b	Reserved
over_temp_wakeup_en	11	RW	0'h	Over-Temperature Wake-Up Enable 0: No wake-up 1: Wake Up
mic1_short_det_wakeup_en	10	RW	0'h	MICBIAS1 Short Current Detect Wake-Up Enable 0: No wake-up 1: Wake Up
mic2_short_det_wakeup_en	9	RW	0'h	MICBIAS2 Short Current Detect Wake-Up Enable 0: No wake-up 1: Wake Up
Reserved	8:6	R	0'h	Reserved. Read as 0
gpio5_wakeup_en	5	RW	0'h	GPIO5 Pin Wake-Up Enable 0: No wake-up 1: Wake Up
gpio4_wakeup_en	4	RW	0'h	GPIO4 Pin Wake-Up Enable 0: No wake-up 1: Wake Up
gpio3_wakeup_en	3	RW	0'h	GPIO3 Pin Wake-Up Enable 0: No wake-up 1: Wake Up
gpio2_wakeup_en	2	RW	0'h	GPIO2 Pin Wake-Up Enable 0: No wake-up 1: Wake Up
gpio1_wakeup_en	1	RW	0'h	GPIO1 Pin Wake-Up Enable 0: No wake-up 1: Wake Up
Reserved	0	R	0'h	Reserved. Read as 0

8.29. Reg-54h: GPIO Pin Status

Default: 003Ah

Table 43. Reg-54h: GPIO Pin Status

Name	Bits	Read/Write	Reset State	Description
Reserved	15:14	R	00'b	Reserved
pendown_status	13	R	0'h	Pen-down Detect Status Read: Return status Write: Writing '0' clears the sticky bit
Reserved	12	R	0'b	Reserved
over_temp_status	11	R	0'h	Over-temperature Status Read: Return status Write: Writing '0' clears the sticky bit
mic1_short_det_status	10	R	0'h	MICBIAS1 Short Current Detect Status Read: Return status Write: Writing '0' clears the sticky bit
mic2_short_det_status	9	R	0'h	MICBIAS2 Short Current Detect Status Read: Return status Write: Writing '0' clears the sticky bit
Reserved	8:6	R	0'h	Reserved. Read as 0
gpio5_status	5	R	1'h	GPIO5 Pin Status Read: Return status of each GPIO pin Write: Writing '0' clears the sticky bit
gpio4_status	4	R	1'h	GPIO4 Pin Status Read: Return status of each GPIO pin Write: Writing '0' clears the sticky bit
gpio3_status	3	R	1'h	GPIO3 Pin Status Read: Return status of each GPIO pin Write: Writing '0' clears the sticky bit
gpio2_status	2	R	1'h	GPIO2 Pin Status Read: Return status of each GPIO pin Write: Writing '0' clears the sticky bit
gpio1_status	1	R	1'h	GPIO1 Pin Status Read: Return status of each GPIO pin Write: Writing '0' clears the sticky bit
Reserved	0	R	0'h	Reserved. Read as 0

8.30. Reg-56h: Pin Sharing

Default: 0000h

Table 44. Reg-56h: Pin Sharing

Name	Bits	Read/Write	Reset State	Description
Reserved	15:3	R	0'h	Reserved
gpio2_pin_sharing	2	RW	0'h	GPIO2 Pin Sharing 0: IRQ_Out 1: GPIO enable
Reserved	1:0	R	0'h	Reserved

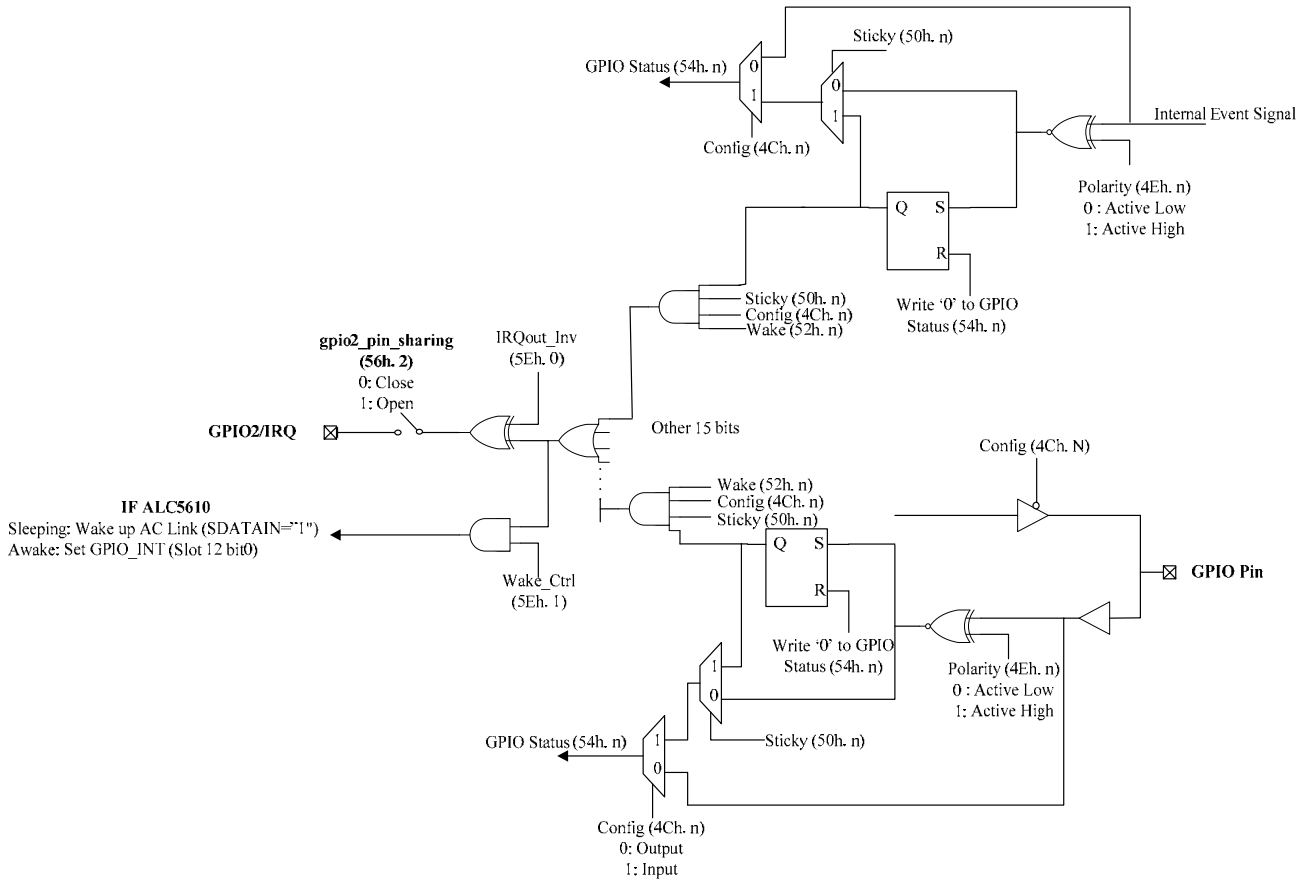
Figure 22. GPIO and IRQ Logic
Table 45. GPIO and IRQ Logic

GPIO Bit Reg54[15:1]	SLOT 12 Bit	Source	Description
1	5	GPIO Pin	GPIO1 Input Status
2	6	GPIO Pin	GPIO2
3	7	GPIO Pin	GPIO3
4	8	GPIO Pin	GPIO4
5	9	GPIO Pin	GPIO5
6	10	-	Unused
7	11	-	Unused
8	12	-	Unused
9	13	VGPIO	MICBIAS2 Short Current Detect
10	14	VGPIO	MICBIAS1 Short Current Detect
11	15	VGPIO	Over-Temperature
12	16	-	Unused
13	17	VGPIO	Pen-Down Detect
14	18	-	Unused
15	19	-	Unused

8.31. Reg-58h: Over-Temp/Current Status

Default: 0CFFh

Table 46. Reg-58h: Over-Temp/Current Status

Name	Bits	Read/Write	Reset State	Description
Reserved	15:12	R	0000'h	Reserved
ovt_hp_status	11	R	1'h	Headphone Amp Over-Temperature 0: Normal 1: Over-temperature
ovt_MONO_status	10	R	1'h	MONO Amp Over-Temperature 0: Normal 1: Over-temperature
ovc_micbias1_status	9	R	0'h	MICBIAS1 Over-Current 0: Normal 1: Over current
ovc_micbias2_status	8	R	0'h	MICBIAS2 Over-Current 0: Normal 1: Over-current
rp_depops_status	7	R	1'h	RP Channel Depop Status 0: Depop ready 1: Depop finished
rn_depops_status	6	R	1'h	RN Channel Depop Status 0: Depop ready 1: Depop finished
lp_depops_status	5	R	1'h	LP Channel Depop Status 0: Depop ready 1: Depop finished
ln_depops_status	4	R	1'h	LN Channel Depop Status 0: Depop ready 1: Depop finished
ovt_rp_status	3	R	1'h	RP Channel Temperature Sensor Status 0: Normal 1: Over-temperature
ovt_rn_status	2	R	1'h	RN Channel Temperature Sensor Status 0: Normal 1: Over-temperature
ovt_lp_status	1	R	1'h	LP Channel Temperature Sensor Status 0: Normal 1: Over-temperature
ovt_ln_status	0	R	1'h	LN Channel Temperature Sensor Status 0: Normal 1: Over-temperature

8.32. Reg-5Ch: GPIO_Output Pin Control

Default: 0000h

Table 47. Reg-5Ch: GPIO_Output Pin Control

Name	Bits	Read/Write	Reset State	Description
Reserved	15:6	R	0000'h	Reserved
gpio5_out_status	5	RW	0'h	GPIO5 Output Pin Control 0b: Drive Low 1b: Drive High
gpio4_out_status	4	RW	0'h	GPIO4 Output Pin Control 0b: Drive Low 1b: Drive High
gpio3_out_status	3	RW	0'h	GPIO3 Output Pin Control 0b: Drive Low 1b: Drive High
gpio2_out_status	2	RW	0'h	GPIO2 Output Pin Control 0b: Drive Low 1b: Drive High
gpio1_out_status	1	RW	0'h	GPIO1 Output Pin Control 0b: Drive Low 1b: Drive High
Reserved	0	R	0'h	Reserved. Read as 0

8.33. Reg-5Eh: MISC Control

Default: 0000h

Table 48. Reg-5Eh: MISC Control

Name	Bits	Read/Write	Reset State	Description
en_vref_fast	15	RW	0'b	Enable Fast Vref 0: Enable fast Vref 1: Disable fast Vref <i>Note: To improve PSRR, en_vref_fast should be disabled before playback/record.</i>
clsab_amp_sel	14	RW	0'b	Class AB Output Amplifier Select 0: Strong Amp 1: Weak Amp <i>Note: Strong Amp, SPKVDD: 3.0V~5V and Set index44[8:6]=100'b Weak Amp, SPKVDD: 2.3V~5V and Setindex44[8:6]=000'b</i>
AVC_target_sel	13:12	RW	0'b	AVC Target Select 00: Reserved (No AVC) 01: R Channel 10: L Channel 11: Both channel
thermal_shutdown_en	11	RW	0'b	Thermal Shutdown Enable 0: Disable 1: Enable

Name	Bits	Read/Write	Reset State	Description
reset_pendown_sel	10	RW	0'b	Reset/Pen-Down Selection 0: Reset Input 1: Pen-down Output <i>Note: Output Reg78[15] status as pen-down signal when Reset_Pendown_sel=1</i> <i>Sequence:</i> 1. Set the GPIO of the controller as output and set the ALC5610 as Reset_Input 2. After Reset, Set the GPIO of the controller as Input and set the ALC5610 as Pendown_Output 3. Enable the GPIO of the controller to receive INT 4. After the controller Received INT, the controller disables INT and starts to check AUXADC 5. Pen-up will be reported by Reg78[15]
Reserved	9:7	RW	0'h	Reserved
main_dac_l_mute	6	RW	0'h	Mute Main DAC Left Input 0: On 1: Mute ($-\infty$ dB)
main_dac_r_mute	5	RW	0'h	Mute Main DAC Right Input 0: On 1: Mute ($-\infty$ dB)
voice_dac_mute	4	RW	0'h	Mute Voice DAC Input 0: On 1: Mute ($-\infty$ dB)
Reserved	3:2	RW	0'h	Reserved
gpio_wakeup_ctrl	1	RW	0'h	GPIO wakeup Control 0: Disable 1: Enable
irqout_inv_ctrl	0	RW	0'h	IRQOUT Inverter Control 0: Normal 1: Invert

The Jack-insert-detect pull-up resistor is implemented via an external circuit (see Figure 23).

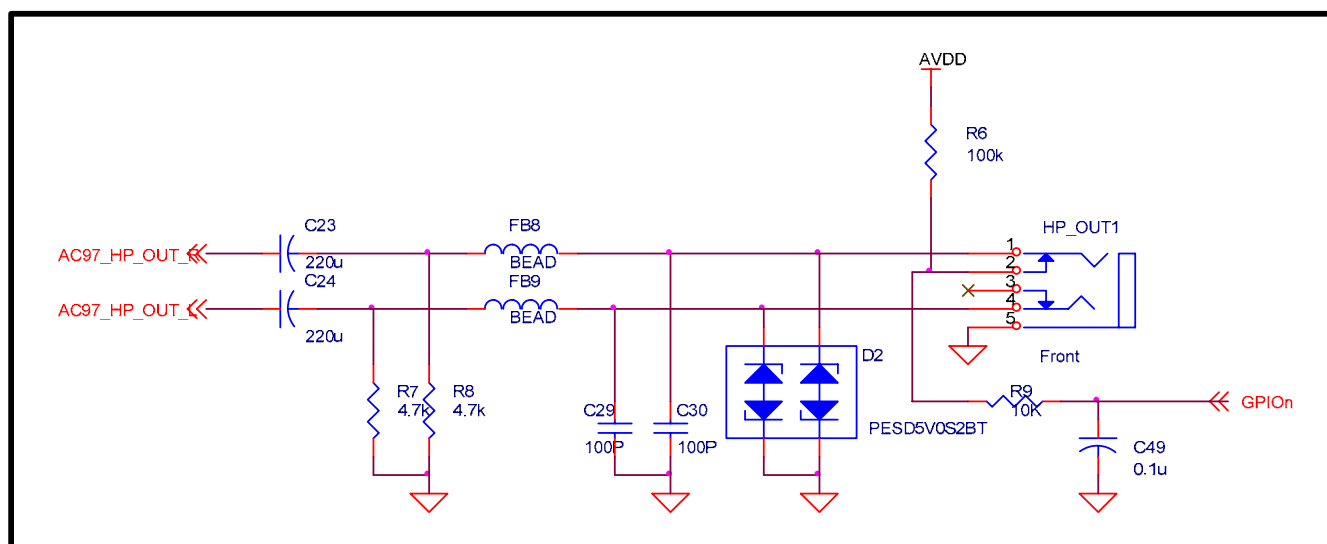

Figure 23. Jack-Insert-Detect Pull-Up Resistor Implemented via an External Circuit

8.34. Reg-64h: VoDAC_PCM Clock Control_1

Default: 2130h

Table 49. Reg-64h: VoDAC_PCM Clock Control_1

Name	Bits	Read/Write	Reset State	Description
voice_mclk_sel	15	RW	0'h	Voice Master-Clock Select 0b: MCLK input 1b: PLL output
voice_sysclk_sel	14	RW	0'h	Voice System-Clock Select 0b: MCLK 1b: EXTCLK
I2s_wclk_voice_master_sel	13	RW	1'h	I ² S Word-Clock Voice Master Select 0b: ÷32 1b: ÷64
Reserved	12:11	R	0'b	Reserved
extclk_out_sel	10:8	RW	1'h	External Clock-Out Select 000b: ÷1 001b: ÷2 010b: ÷4 011b: ÷8 100b: ÷16 Others: Reserved
I2s_sclk_voice_master_sel_1	7:4	RW	3'h	I ² S Bit-Clock Voice Master Select 1 0000b: ÷1 0001b: ÷2 0010b: ÷3 1101b: ÷14 1110b: ÷15 1111b: ÷16
Reserved	3	R	0'b	Reserved
I2s_sclk_voice_master_sel_2	2:0	RW	0'h	I ² S Bit-Clock Voice Master Select 2 000b: ÷2 001b: ÷4 010b: ÷8 011b: ÷16 100b: ÷32 Others: Reserved

Note: The driver must determine the Voice AD/DA filter clock, and select the filter by setting Voice_64osr (see Table 50).

8.35. Reg-66h: VoDAC_PCM Clock Control_2

Default: 0010h

Table 50. Reg-66h: VoDAC_PCM Clock Control_2

Name	Bits	Read/Write	Reset State	Description
sel_clk_filter_slave	15	RW	0'h	Select Voice Clock Filter Slave 0b: ÷1 1b: ÷2
sel_clk_filter	14	RW	0'h	Select Voice Clock Filter Source 0b: From MCLK/EXTCLK 1b: From VBCLK
voice_64osr	13	RW	0'h	Voice DA/AD Filter Select 0b: 128x 1b: 64x
Reserved	12:8	R	0'h	Reserved
clk_filter_master_sel_1	7:4	RW	1'h	Clock Filter Master Select 1 000b: ÷1 001b: ÷2 010b: ÷3 1101b: ÷14 1110b: ÷15 1111b: ÷16
Reserved	3	R	0'h	Reserved
clk_filter_master_sel_2	2:0	RW	0'h	Clock Filter Master Select 2 000b: ÷2 001b: ÷4 010b: ÷8 011b: ÷16 100b: ÷32 Others: Reserved

8.36. Reg-68h: Pseudo Stereo and Spatial Effect Block Control

Default: 0053h

Table 51. Reg-68h: Pseudo Stereo and Spatial Effect Block Control

Name	Bits	Read/Write	Reset State	Description
spatial_ctrl_enable	15	RW	0'b	Spatial Enable 0b: Disable (Clear internal state) 1b: Enable
apf_en	14	RW	0'h	Enable All Pass Filter APF(z) (EN-APF) 0: Disable (Bypass) and reset. 1: Enable all pass filters. The coefficient a1 is loaded from apf_parm_a1[7:0]
pseudo_stereo_en	13	RW	0'h	Enable Pseudo Stereo Block (EN-PSB) 0: Disabled 1: Enabled
en_3d	12	RW	0'h	Enable Stereo Expansion Block (EN-SEB) 0: Disable 1: Enabled. Load 3D Ratio from ratio_parm_3d and 3D Gain from gain_parm_3d
Reserved	11:8	-	0'h	Reserved
gain_parm_3d	7:6	RW	1'h	3D Gain Parameter (SEGn) 00: Gain=1.0 01: Gain=1.5 10: Gain=2.0 11: Reserved
ratio_parm_3d	5:4	RW	1'h	3D Ratio Parameter (DPn) 00: Ratio=0.0 01: Ratio=0.66 10: Ratio=1.0 11: Reserved
Reserved	3:2	-	0'h	Reserved
apf_parm_a1	1:0	RW	3'h	All Pass Filter Parameter 00: Disable 01: Enable for 32kHz sample rate or lower 10: Enable for 44.1kHz sample rate 11: Enable for 48kHz sample rate

Note: Writes to SEGn and DPn will be ignored when the Spatial effect control bit is enabled. This means individual Spatial coefficients cannot be modified when Spatial is enabled.

8.37. Reg-6Ah: Index Address

Default: 0000h

Table 52. Reg-6Ah: Index Address

Name	Bits	Read/Write	Reset State	Description
Reserved	15:7	R	0'h	Reserved
index_addr	6:0	RW	0'h	Index Address

8.38. Reg-6Ch: Index Data

Default: 0000h

Table 53. Reg-6Ch: Index Data

Name	Bits	Read/Write	Reset State	Description
index_data	15:0	RW	0'h	Index Data

8.39. Reg-6Eh: EQ Status

Default: 0000h

Table 54. Reg-6Eh: EQ Status

Name	Bits	Read/Write	Reset State	Description
Reserved	15:5	R	0'h	Reserved
eq_hpf_status	4	R	0'h	EQ High-Pass Filter (HPF) Status 0: Normal 1: Overflow. This bit is set if overflow has occurred. Write 1 to clear.
eq_bpf3_status	3	R	0'h	EQ Band-3 (BP3) Status 0: Normal 1: Overflow. This bit is set if overflow has occurred. Write 1 to clear.
eq_bpf2_status	2	R	0'h	EQ Band-2 (BP2) Status 0: Normal 1: Overflow. This bit is set if overflow has occurred. Write 1 to clear.
eq_bpf1_status	1	R	0'h	EQ Band-1 (BP1) Status 0: Normal 1: Overflow. This bit is set if overflow has occurred. Write 1 to clear.
eq_lpf_status	0	R	0'h	EQ Low-Pass Filter (LPF) Status 0: Normal 1: Overflow. This bit is set if overflow has occurred. Write 1 to clear.

8.40. Index-00h: EQ Band-0 Coefficient (LP0: a1)

Default: 0000h

Table 55. Index-00h: EQ Band-0 Coefficient (LP0: a1)

Bit	Type	Function
15:0	RW	2's complement in 3.13 formats (The range is from -4~3.99, the a1 should be in -2 ~ 1.99)

Note: For low pass filter for Bass control – LP0 has filter coefficient a1 and gain Ho must be set (see Table 56).

8.41. Index-01h: EQ Band-0 Gain (LP0: Ho)

Default: 0000h

Table 56. Index-01h: EQ Band-0 Gain (LP0: Ho)

Bit	Type	Function
15:0	RW	2's complement in 3.13 format (The range is from -4~3.99, the Ho should be in -4 ~ 3.99)

8.42. Index-02h: EQ Band-1 Coefficient (BP1: a1)

Default: 0000h

Table 57. Index-02h: EQ Band-1 Coefficient (BP1: a1)

Bit	Type	Function
15:0	RW	2's complement in 3.13 format (The range is from -4~3.99, the a1 should be in -2 ~ 1.99)

8.43. Index-03h: EQ Band-1 Coefficient (BP1: a2)

Default: 0000h

Table 58. Index-03h: EQ Band-1 Coefficient (BP1: a2)

Bit	Type	Function
15:0	RW	2's complement in 3.13 format (The range is from -4~3.99, the a1 should be in -2 ~ 1.99)

8.44. Index-04h: EQ Band-1 Gain (BP1: Ho)

Default: 0000h

Table 59. Index-04h: EQ Band-1 Gain (BP1: Ho)

Bit	Type	Function
15:0	RW	2's complement in 3.13 format (The range is from -4~3.99, the Ho should be in -4 ~ 3.99)

8.45. Index-05h: EQ Band-2 Coefficient (BP2: a1)

Default: 0000h

Table 60. Index-05h: EQ Band-2 Coefficient (BP2: a1)

Bit	Type	Function
15:0	RW	2's complement in 3.13 format (The range is from -4~3.99, the a1 should be in -2 ~ 1.99)

8.46. Index-06h: EQ Band-2 Coefficient (BP2: a2)

Default: 0000h

Table 61. Index-06h: EQ Band-2 Coefficient (BP2: a2)

Bit	Type	Function
15:0	RW	2's complement in 3.13 format (The range is from -4~3.99, the a2 should be in -2 ~ 1.99)

8.47. Index-07h: EQ Band-2 Gain (BP2: Ho)

Default: 0000h

Table 62. Index-07h: EQ Band-2 Gain (BP2: Ho)

Bit	Type	Function
15:0	RW	2's complement in 3.13 format (The range is from -4~3.99, the Ho should be in -4 ~ 3.99)

8.48. Index-08h: EQ Band-3 Coefficient (BP3: a1)

Default: 0000h

Table 63. Index-08h: EQ Band-3 Coefficient (BP3: a1)

Bit	Type	Function
15:0	RW	2's complement in 3.13 format (The range is from -4~3.99, the a1 should be in -2 ~ 1.99)

8.49. Index-09h: EQ Band-3 Coefficient (BP3: a2)

Default: 0000h

Table 64. Index-09h: EQ Band-3 Coefficient (BP3: a2)

Bit	Type	Function
15:0	RW	2's complement in 3.13 format (The range is from -4~3.99, the a2 should be in -2 ~ 1.99)

8.50. Index-0Ah: EQ Band-3 Gain (BP3: Ho)

Default: 0000h

Table 65. Index-0Ah: EQ Band-3 Gain (BP3: Ho)

Bit	Type	Function
15:0	RW	2's complement in 3.13 format (The range is from -4~3.99, the Ho should be in -4 ~ 3.99)

8.51. Index-0Bh: EQ Band-4 Coefficient (HPF: a1)

Default: 0000h

Table 66. Index-0Bh: EQ Band-4 Coefficient (HPF: a1)

Bit	Type	Function
15:0	RW	2's complement in 3.13 format (The range is from -4~3.99, the a1 should be in -2 ~ 1.99)

8.52. Index-0Ch: EQ Band-4 Gain (HPF: Ho)

Default: 0000h

Table 67. Index-0Ch: EQ Band-4 Gain (HPF: Ho)

Bit	Type	Function
15:0	RW	2's complement in 3.13 format (The range is from -4~3.99, the Ho should be in -2 ~ 1.99)

8.56. Index-20h: Auto Volume Control Register 0

Default: 0050h

Table 71. Index-20h: Auto Volume Control Register 0

Bit	Type	Function
15	RW	Select the Controlled Gain Block for AVC (Default: 00b) 0: Disable AVC 1: Enable AVC to control ADC gain
14:8	-	Reserved
7:3	RW	Monitor Window Control (Unit: $2^{(n+1)}$ samples) (Default: 01010b) 00000b: $2^{(1)}$ sample 00001b: $2^{(2)}$ samples 00010b: $2^{(3)}$ samples ... 10000b: $2^{(17)}$ samples Others: Reserved. Maximum n=16 <i>Note: The Monitor Window can only be changed after soft-reset when AVC is enabled</i>
2:1	-	Reserved
0	RW	AVC Reference Channel Selection (Default: 0b) 0: Left Channel 1: Right Channel

8.57. Index-21h: Auto Volume Control Register 1

Default: 2710h

Table 72. Index-21h: Auto Volume Control Register 1

Bit	Type	Function
15	-	Reserved
14:0	RW	The Maximum PCM absolute level after AVC, T_{max} ($=0 \sim 2^{15}-1$)

8.58. Index-22h: Auto Volume Control Register 2

Default: 0BB8h

Table 73. Index-22h: Auto Volume Control Register 2

Bit	Type	Function
15	-	Reserved
14:0	RW	The Minimum PCM absolute level after AVC, T_{min} ($=0 \sim 2^{15}-1$)

8.59. Index-23h: Auto Volume Control Register 3

Default: 01F4h

Table 74. Index-23h: Auto Volume Control Register 3

Bit	Type	Function
15	-	Reserved
14:0	RW	The Non-active PCM absolute level AVC will keep analog unit gain, Thnonact (=0 ~ 2 ¹⁵ -1)

Note: Initial Index23=0001'h

8.60. Index-24h: Auto Volume Control Register 4

Default: 0190h

Table 75. Index-24h: Auto Volume Control Register 4

Bit	Type	Function
15:0	RW	The CNTMAXTH1 to control the sensitivity to increase Gain (Unit:2 ¹) This value should be less than CNTMAXTH2 (Max:2 ¹⁷)

8.61. Index-25h: Auto Volume Control Register 5

Default: 0200h

Table 76. Index-25h: Auto Volume Control Register 5

Bit	Type	Function
15:0	RW	The CNTMAXTH2 to control the sensitivity to decrease Gain (Unit:2 ¹) This value should be less than Monitor Window. (Optimized: 1/2 Monitor Window) (Max:2 ¹⁷)

Note: CNTMAXTH1 < CNTMAXTH2

8.62. Index-39h: Digital Internal Register

Default: 9000h

Table 77. Index-39h: Digital Internal Register

Bit	Type	Function
15	RW	Pad Drive Capability 0b: Weak drive 1b: Strong drive
14:0	RW	Reserved

8.63. Index-4Ah: Class D Temperature Sensor

Default: 4444h

Table 78. Index-4Ah: Class D Temperature Sensor

Bit	Type	Function
15	RW	Reserved
14:12	RW	RP Channel Temp. Sensor Threshold Setting 001: 35°C 011: 65°C 101: 95°C 111: 125°C
11	RW	Reserved
10:8	RW	RN Channel Temp. Sensor Threshold Setting 001: 35°C 011: 65°C 101: 95°C 111: 125°C
7	RW	Reserved
6:4	RW	LP Channel Temp. Sensor Threshold Setting 001: 35°C 011: 65°C 101: 95°C 111: 125°C
3	RW	Reserved
2:0	RW	LN Channel Temp. Sensor Threshold Setting 001: 35°C 011: 65°C 101: 95°C 111: 125°C

Note: Tolerance: $\pm 15^{\circ}\text{C}$

8.64. Index-54h: AD_DA_Mixer_Internal Register

Default: 8184h

Table 79. Index-54h: AD_DA_Mixer_Internal Register

Bit	Type	Function
15	RW	Reserved
14:13	RW	DAC Reference Source 01: Internal DAC reference (AVDD1 & DAC reference cannot be bonded together) 11: External DAC reference (AVDD/AGND as DAC reference) Others: Forbidden
12:3	RW	Reserved
2:0	RW	Temp. Sensor for Threshold Setting 001: 35°C 011: 65°C 101: 95°C 111: 125°C Note: Tolerance: $\pm 15^{\circ}\text{C}$

Note: To reduce DAC power consumption, we suggest that Index54=E184'h be initialized.

8.65. Reg-74h: Touch Panel Control Byte 1

Default: 008Ch

Table 80. Reg-74h: Touch Panel Control Byte 1

Name	Bits	Read/Write	Reset State	Description
pow_tp_ctrl	15:14	RW	0'h	Touch Panel Power Control 00: All OFF 01: AUX_ADC is OFF, pen-down is ON, and AUX_ADC will be turned ON once pen-down is detected. 10: AUX_ADC is OFF, pen-down is ON, but AUX_ADC will not be turned ON even if pen-down is detected. 11: AUX_ADC ON
pressure_source_current	13:10	RW	0'h	Pressure Measurement Source Current 0000b: OFF 0001b: 25μA 0010b: 50μA 1111b: 375μA
Reserved	9	RW	0'h	Reserved
tp_adc_delay_sel	8:7	RW	1'h	Touch Panel ADC Measure Delay After Switch Matrix Setting Change (1 Frame =20.8μs) 00: 4 frame 01: 8 frame (Default) 10: 16 frame 11: 32 frame
slot_readback_En	6	RW	0'b	Slot Readback Enable (Control for continuous and polling mode) 0b: Disable 1b: Enable
tp_slot_sel	5	RW	0'h	AC'97 Slot Select 0: Slot 5 1: Slot 6
tp_clk_div	4:2	RW	3'h	AUX ADC Clock Divider 000~010: Reserved 011: ÷64 (Default) 100: ÷80 101: ÷96 110: ÷112 111: ÷128
conversion_rate_sel	1:0	RW	0'h	Conversion Rate Select for No Delay Setting 00: 93.75Hz (512 frames) 01: 124.67Hz (384 frames) 10: 187.5Hz (256 frames) 11: 374Hz (128 frames)

8.66. Reg-76h: Touch Panel Control Byte 2

Default: 3F00h

Table 81. Reg-76h: Touch Panel Control Byte 2

Name	Bits	Read/Write	Reset State	Description
polling_trig	15	RW	0'h	Writing 1 initiates a measurement in polling mode. This bit will self-clear when measured data is received
tp_adc_mode_sel	14	RW	0'h	Touch Panel ADC Data Mode Select During Position Measurement 0: Polling mode 1: Continuous mode
pd_pullup_resistor_sel	13:8	RW	3F'h	Programmable Internal Pull-up Resistor For Pen-down Detection 000000: 1K Ohm 000001: 2K Ohm 000010: 3K Ohm 111111: 64Kohm
AUX_measure_en	7	RW	0'h	AUX Measurement 0: Disable 1: Enable
Reserved	6:4	R	0'h	Reserved
pressure_measure_en	3	RW	0'h	Pressure Measurement 0: Disable 1: Enable
y_measure_en	2	RW	0'h	Y Co-Ordinate Measurement 0: Disable 1: Enable
x_measure_en	1	RW	0'h	X Co-Ordinate Measurement 0: Disable 1: Enable
AUX_measure_sel	0	RW	0'h	AUX3/AUX4 Measure Selection 0:AUX4 1:AUX3

8.67. Reg-78h: Touch Panel Indication

Default: 0000h

Table 82. Reg-78h: Touch Panel Indication

Name	Bits	Read/Write	Reset State	Description
pen_status	15	R	0'h	Indicates Pen Status after AUX_ADC Measured 0: Pen-up 1: Pen-down
pipe_adc_source	14:12	R	0'h	AUX ADC Source 000: No Data (AUX_ADC Busy) 001: X co-ordinate measurement 010: Y co-ordinate measurement 011: Pressure measurement 100: Reserved 101: Reserved 110: Reserved 111: AUX
pipe_adc_rpt	11:0	R	0'h	AUX ADC Data Report

8.68. Reg-7Ch: VENDOR ID 1

Default: 10ECh

Table 83. Reg-7Ch: VENDOR ID 1

Name	Bits	Read/Write	Reset State	Description
vender_id1	15:0	R	10EC'h	Vendor ID=10EC

8.69. Reg-7Eh: VENDOR ID 2

Default: 1003h

Table 84. Reg-7Eh: VENDOR ID 2

Name	Bits	Read/Write	Reset State	Description
vender_id	15:8	R	10'h	Device ID=10
device_id2	7:0	R	03'h	Version ID=03

9. Electrical Characteristics

9.1. DC Characteristics

9.1.1. Absolute Maximum Ratings

Table 85. Absolute Maximum Ratings

Parameter	Symbol	Min	Typ	Max	Units
Power Supplies					
Digital IO Buffer	DVDD1	-0.3	-	3.63	V
Digital Core	DVDD2	-0.3	-	3.63	V
Analog	AVDD	-0.3	-	3.63	V
Touch Panel	TPVDD	-0.3	-	3.63	V
Headphone	HPVDD	-0.3	-	3.63	V
Speaker	SPKVDD	-0.3	-	7 ¹	V
Operating Ambient Temperature	Ta	-25	-	+85	°C
Storage Temperature	Ts	-55	-	+125	°C

Note 1: SPKVDD=5V with 3.5% duty cycle Power bouncing up to SPKVDD=8V is acceptable.

9.1.2. Recommended Operating Conditions

Table 86. Recommended Operating Conditions

Parameter	Symbol	Min	Typ	Max	Units
Digital IO Buffer	DVDD1	1.8	3.3	3.6	V
Digital Core	DVDD2	1.8	3.3	3.6	V
Analog	AVDD	2.3	3.3	3.6	V
Touch Panel	TPVDD	2.3	3.3	3.6	V
Headphone	HPVDD	2.3	3.3	3.6	V
Speaker	SPKVDD ¹	2.3	3.3	5	V

Note 1: A 10 μ F Capacitor must be connected from SPKVDD to AGND, and should be placed as close as possible to the SPKVDD pin of the ALC5610.

9.1.3. Static Characteristics

Table 87. Static Characteristics

Parameter	Symbol	Min	Typ	Max	Units
Low Level Input Voltage	V _{IL}	-	-	0.35DVDD	V
High Level Input Voltage	V _{IH}	0.65DVDD	-	-	V
High Level Output Voltage	V _{OH}	0.9DVDD	-	-	V
Low Level Output Voltage	V _{OL}	-	-	0.1DVDD	V
Input Leakage Current	-	-1	-	1	μ A
Output Leakage Current (Hi-Z)	-	-1	-	1	μ A
Output Buffer High Drive Current	-	-	22	-	mA
Output Buffer Low Drive Current	-	-	10	-	mA
V _{MID} Internal Serial Resistor	-	25	50	75	K Ω
V _{MID} Internal Serial Resistor Ratio	-	95	100	105	%

Note: DVDD=3.3V, T_{ambient}=25 °C, with 50pF external load.

9.2. Analog Performance Characteristics

Table 88. Analog Performance Characteristics

Parameter	Min	Typ	Max	Units
Full Scale Input Voltage				
Line Inputs	-	1.0	-	Vrms
MIC Inputs (Non-Boost)	-	1.0	-	Vrms
MIC Inputs (Boost 20dB)	-	0.1	-	Vrms
ADC	-	0.7	-	Vrms
Full Scale Output Voltage				
MONO Outputs	-	1.0	-	Vrms
Headphone Amplifiers Outputs	-	1.0	-	Vrms
Speaker Amplifiers Outputs	-	1.3	-	Vrms
S/N Ratio (A-weighted, HPL/R or MONO with 10K Ω /50pF load)				
STEREO DAC	-	90	-	dB
STEREO ADC	-	85	-	dB
Voice DAC	-	70	-	dB
Total Harmonic Distortion + Noise (A-weighted, HPL/R or MONO with 10K Ω /50pF load)				
STEREO DAC	-	-85	-	dB
STEREO ADC	-	-80	-	dB
Voice DAC	-	-60	-	dB
MIC Boost Amplifier				
Gain=20dB	18	20	22	dB
Gain=30dB	-	30	-	dB
Gain=40dB	-	40	-	dB
Input Impedance (Gain=0dB, ADC Mixer=On/Off)				
PHONEN (Differential Mode)	-	16	-	K Ω
MIC1N, MIC2N (Differential Mode)	-	16	-	K Ω
MIC1P, MIC2P	-	16	-	K Ω
PHONEP	-	16	-	K Ω
Input Impedance (Gain=0dB, ADC Mixer=On)				
LINE_IN	12.8	16	19.2	K Ω
Input Impedance (Gain=0dB, ADC Mixer=Off)				
LINE_IN	25.6	32	38.4	K Ω
Output Impedance				
MONO_OUT	-	2	-	Ω
HP_OUT	-	2	-	Ω
SPK_OUT (Class AB)	-	1	-	Ω
SPK_OUT (Class D)	-	0.3	0.4	Ω
MONO_OUT Amplifier Output Power (32 Ω Load)				
Single End Mode	25	-	-	mW
BTL Mode	75	-	-	mW

Parameter	Min	Typ	Max	Units
MONO_OUT Amplifier Quiescent Current (32Ω Load)/CH	-	700	-	μA
MONO_OUT Amplifier Efficiency (f _{IN} =1kHz, 32Ω Load)				
Single End Mode (Output Power=25mW)	50	-	-	%
BTL Mode (Output Power=75mW)	50	-	-	%
MONO_OUT Amplifier THD+N				
Single End Mode (10KΩ Load)				
Output Power=0.1mW	-	0.01	-	%
BTL Mode (10KΩ Load)				
Output Power=0.1mW	-	0.01	-	%
MONO_OUT Amplifier PSRR	-	50	-	dB
Headphone Amplifier Output Power (32Ω Load)	-	-	31.25	mW
Headphone Amplifier Quiescent Current (32Ω Load)	-	700	-	μA
Headphone Amplifier Efficiency (f _{IN} =1kHz, 32Ω Load, Output Power=25mW)	50	-	-	%
Headphone Amplifier THD+N (32Ω Load)				
Output Power=20mW	-	70	-	dB
Output Power=25mW	-	70	-	dB
Headphone Amplifier PSRR	-	50	-	dB
BTL Speaker Amplifier Output Power (SPKVDD=5V with 8Ω Load)	-	1	-	W
BTL Speaker Amplifier Quiescent Current				
Class AB_Strong (8Ω Load)	-	-	11	mA
Class D	-	-	4	mA
BTL Speaker Amplifier Efficiency (f _{IN} =1kHz, 8Ω Load, Output Power=700 mW)				
Class AB	50	-	-	%
Class D	-	82	-	%
BTL Speaker Amplifier THD + N (8Ω Load)				
Class AB_Strong (8Ω Load)				
Output Power=350mW	-	70	-	dB
Output Power=600mW	-	70	-	dB
Class D				
Output Power=350mW	-	70	-	dB
Output Power=600mW	-	60	-	dB
BTL Speaker Amplifier THD + N Class AB_Weak (10KΩ/50pF Load)	-	-85	-	dB
BTL Speaker Amplifier SNR Class AB_Weak (10KΩ/50pF Load)	-	-90	-	dB
BTL Speaker Amplifier PSRR	-	50	-	dB
Power Supply Current				
I _{DDA} (Analog Block)	-	-	15	mA
I _{DDD} (Digital Block)	-	-	20	mA

Parameter	Min	Typ	Max	Units
Power Down Current				
I _{DDA} (Analog Block)	-	-	10	μA
I _{DDD} (Digital Block)	-	-	1	μA
MICBIAS1 Output Voltage				
0.75*Avdd Setting	-	2.475	-	V
0.9*Avdd Setting	-	2.97	-	V
MICBIAS1 and MICBIAS2 Drive Current	-	16	-	mA
MICBIAS2 Output Voltage				
0.75*Avdd Setting	-	2.475	-	V
0.9*Avdd Setting	-	2.97	-	V
Vref Pull Up Resistor	-	50	-	KΩ

Note: Standard test conditions

T_{ambient} = 25 °C, DVDD = AVDD = HPVDD=3.3V, SPKVDD = 4.2V

1kHz input sine wave; PCM Sampling frequency = 48kHz; 0dB = 1V_{rms}, Test bench Characterization BW: 10Hz~22kHz, 0dB attenuation; EQ and 3D disabled

9.3. Signal Timing

9.3.1. Cold Reset

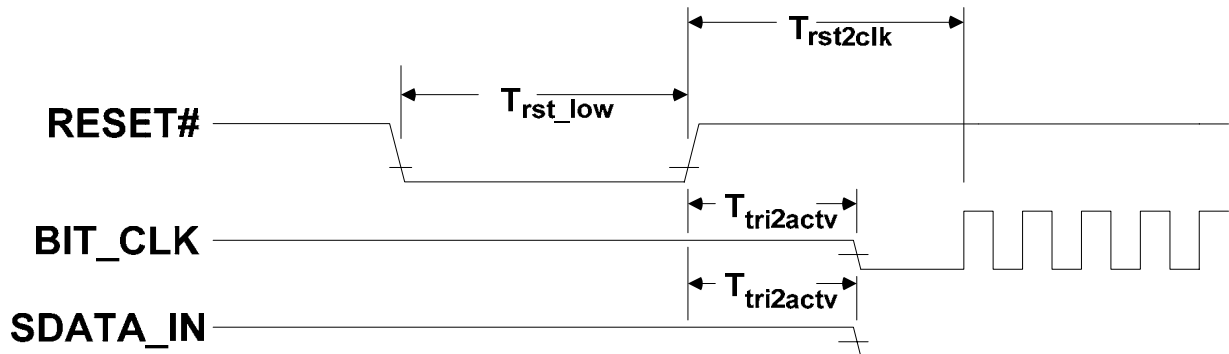

Figure 24. Cold Reset Timing

Table 89. Cold Reset Timing Parameters

Parameter	Symbol	Min	Typ	Max	Units
RESET# Active Low Pulse Width	T_{rst_low}	1.0	-	-	μs
RESET# Inactive to SDATA-IN or BITCLK Active Delay	$T_{tri2actv}$	-	-	25	ns
RESET# Inactive to BIT_CLK Startup Delay	$T_{rst2clk}$	162.8	-	-	ns

9.3.2. Warm Reset

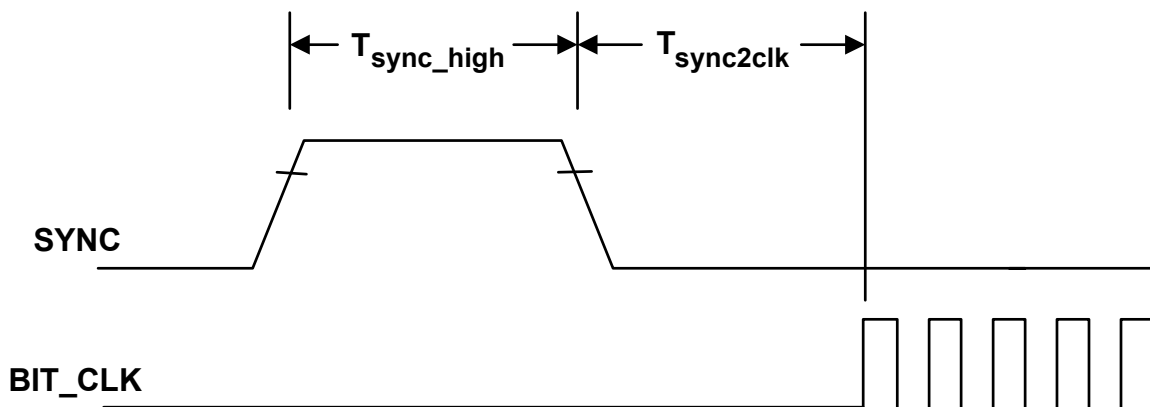

Figure 25. Warm Reset Timing

Table 90. Warm Reset Timing Parameters

Parameter	Symbol	Min	Typ (Design)	Max	Units
SYNC Active High Pulse Width	T_{sync_high}	1.0	1.3 (16 BCLK)	-	μs
SYNC Inactive to BIT_CLK Startup Delay	$T_{sync2clk}$	0.1628	-	400	μs

9.3.3. AC-Link Clock Parameters

Table 91. AC-Link Clock Parameters

Parameter	Symbol	Min	Typ	Max	Units
BIT_CLK Frequency	-	-	12.288	-	MHz
BIT_CLK Period	T_{clk_period}	-	81.4	-	ns
BIT_CLK Output Jitter	-	-	-	750	ps
BIT_CLK High Pulse Width (Note 2)	T_{clk_high}	36	40.7	45	ns
BIT_CLK Low Pulse Width (Note 2)	T_{clk_low}	36	40.7	45	ns
SYNC Frequency	-	-	48.0	-	kHz
SYNC Period	T_{sync_period}	-	20.8	-	μ s
SYNC High Pulse Width	T_{sync_high}	-	1.3	-	μ s
SYNC Low Pulse Width	T_{sync_low}	-	19.5	-	μ s

Note: Worse case duty cycle restricted to 45/55.

9.3.4. AC-Link Data Output and Input Timing

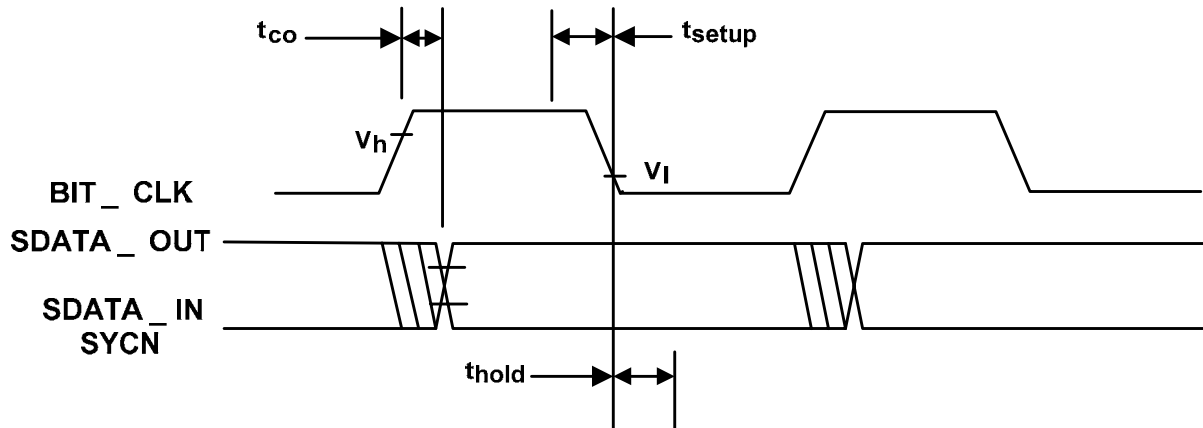
Figure 26. Data Output and Input Timing
Table 92. AC-Link Data Timing Parameters

Parameter	Symbol	Min	Typ	Max	Units
Output Valid Delay from Rising Edge of BIT_CLK	t_{co}	-	-	15	ns

Note 1: Timing is for SDATA and SYNC outputs with respect to BIT_CLK at the device driving the output.

Note 2: 50pF external load

Parameter	Symbol	Min	Typ	Max	Units
Input Setup to Falling Edge of BIT_CLK	t_{setup}	10	-	-	ns
Input Hold from Falling Edge of BIT_CLK	t_{hold}	10	-	-	ns

Note: Timing is for SDATA and SYNC outputs with respect to BIT_CLK at the device driving the output.

Parameter	Symbol	Min	Typ	Max	Units
BIT_CLK Combined Rise or Fall Plus Flight Time	-	-	-	7	ns
SDATA Combined Rise or Fall Plus Flight Time	-	-	-	7	ns

Note: Combined rise or fall plus flight times are provided for worst case scenario modeling purposes.

9.3.5. AC-Link Signal Rise and Fall Timing

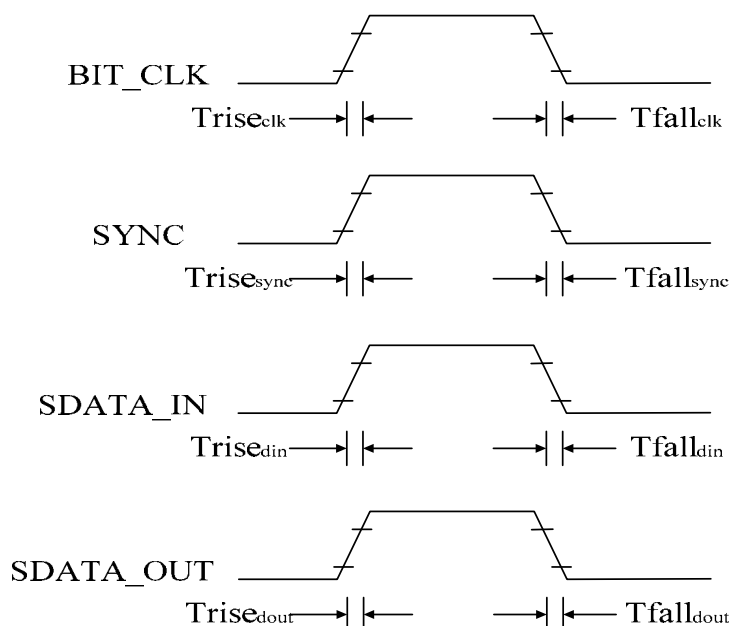

Figure 27. Signal Rise and Fall Timing

Table 93. AC-Link Signal Rise and Fall Timing Parameters

Parameter	Symbol	Min	Typ	Max	Units
BIT_CLK Rise Time	T_{rise_clk}	-	-	6	ns
BIT_CLK Fall Time	T_{fall_clk}	-	-	6	ns
SYNC Rise Time	T_{rise_sync}	-	-	6	ns
SYNC Fall Time	T_{fall_sync}	-	-	6	ns
SDATA_IN Rise Time	T_{rise_din}	-	-	6	ns
SDATA_IN Fall Time	T_{fall_din}	-	-	6	ns
SDATA_OUT Rise Time	T_{rise_dout}	-	-	6	ns
SDATA_OUT Fall Time	T_{fall_dout}	-	-	6	ns

Note 1: 55pF external load (50 pF in AC'97 rev2.1), only for PC system verify case

Note 2: Rise is from 10% to 90% of V_{dd} (V_{ol} to V_{oh})

Note 3: Fall is from 90% to 10% of V_{dd} (V_{oh} to V_{ol})

9.3.6. AC-Link Low Power Mode Timing

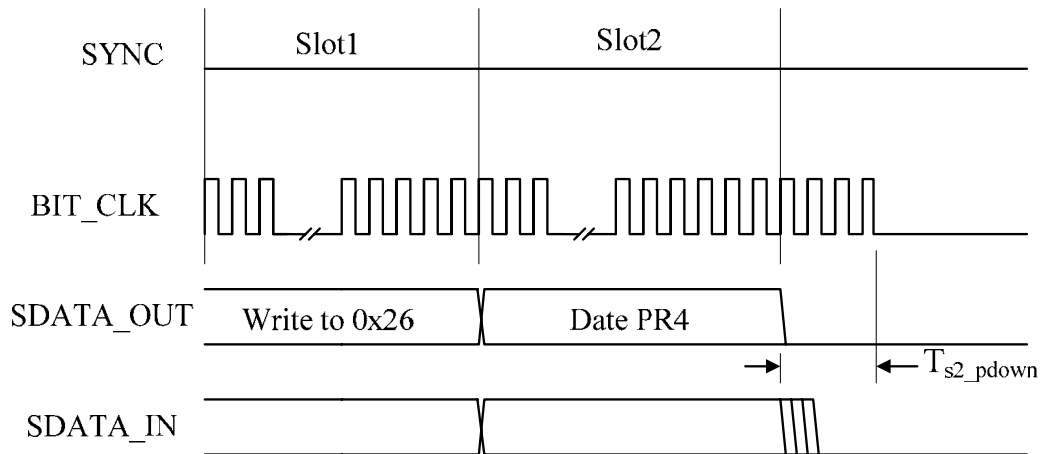

Figure 28. AC-Link Low Power Mode Timing

Table 94. AC-Link Low Power Mode Timing Parameters

Parameter	Symbol	Min	Typ	Max	Units
End of Slot 2 to BIT_CLK, SDATA_IN Low	T_{s2_pdown}	-	-	1.0	μs

9.3.7. AC-Link IO Pin Capacitance and Loading

Table 95. AC-Link IO Pin Capacitance Parameters

Output Pin	For PC	For PDA	Units
RESET#, SYNC & SDATA_OUT	47.5	25	pF
BIT_CLK	47.5	25	pF
SDATA_IN	47.5	25	pF

10. Application Circuits

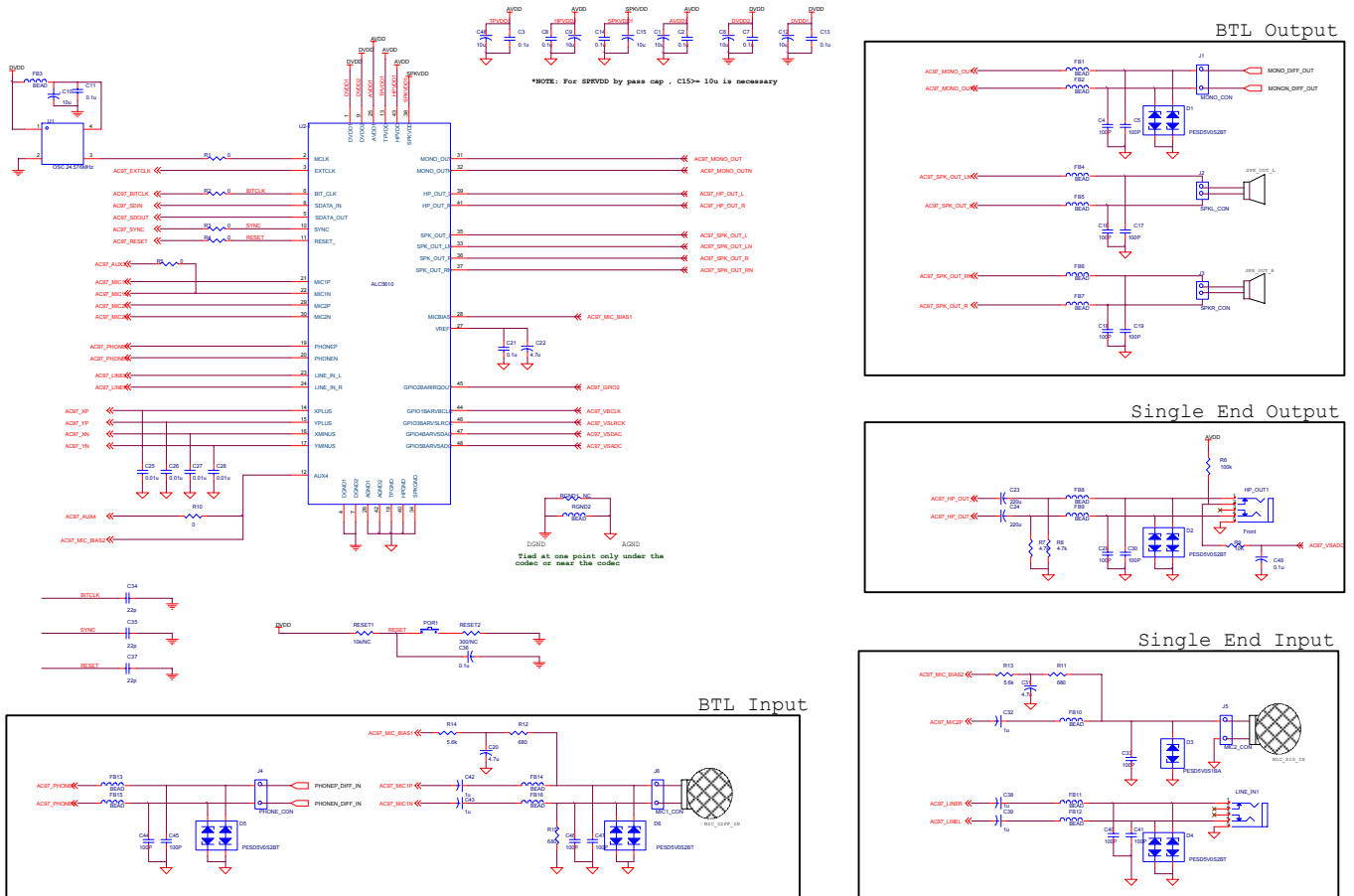

11. Mechanical Dimensions

Symbol	Dimension in mm			Dimension in inch		
	MIN	NCM	MAX	MIN	NCM	MAX
A	0.80	0.85	1.00	0.031	0.033	0.039
A1	0.00	0.02	0.05	0.000	0.001	0.002
A2	---	0.65	1.00	---	0.026	0.039
A3	---	0.20	---	---	0.008	---
b	0.18	0.23	0.30	0.007	0.009	0.012
D	7.00 BSC			0.276 BSC		
D1	6.75 BSC			0.266 BSC		
D2	2.25	4.70	5.25	0.089	0.185	0.207
E	7.00 BSC			0.276 BSC		
E1	6.75 BSC			0.266 BSC		
E2	2.25	4.70	5.25	0.089	0.185	0.207
e	0.5 BSC			0.020 BSC		
L	0.30	0.40	0.50	0.012	0.016	0.020
φ	φ	---	1.2	φ	---	1.2
φφφ	---	---	0.25	---	---	0.010
bbb	---	---	0.10	---	---	0.004
Chamfer	---	---	0.60	---	---	0.024

NOTE:

1. CONTROLLING DIMENSION : MILLIMETER
2. REFERENCE DOCUMENT: PROPOSED JEDEC MO-220.

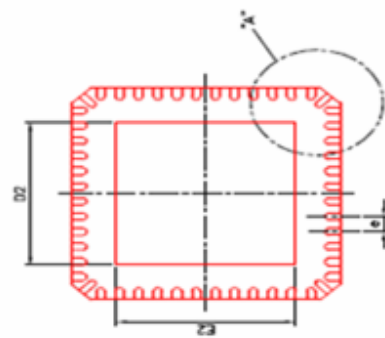
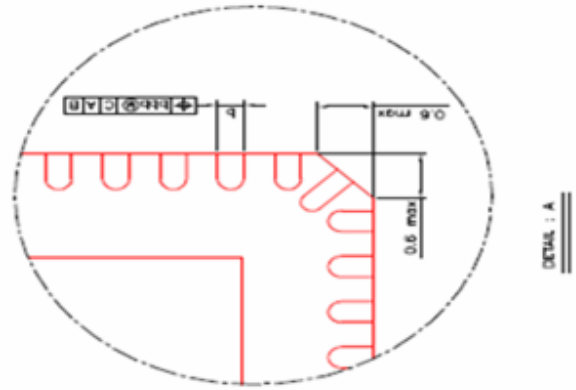
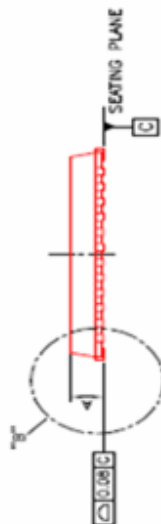
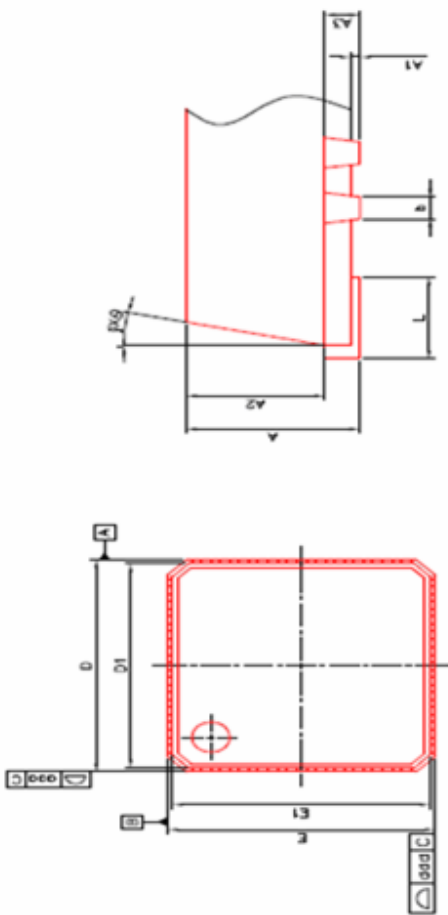

12. Appendix A: Voice PCM Interface

12.1. Master Mode: (voice_port_sel=0)

MCLK	EXTCLK	PLL	VoDAC Sample Rate	Voice_mclk_sel	Voice_	Clk_filter_m aster_div	I2S_selk_vo ice_master_ div	I2S_wclk_v oice_master_ sel	Extclk_out_ sel	Voice_64osr	Extclk_dir	VBCLK (Output)
					sysclk_sel							
				Reg64[15]	Reg64[14]	Reg66[7:4]* Reg66[2:0]	Reg64[7:4]* Reg64[2:0]	Reg64[13]	Reg64[10:3]	Reg66[13]	Reg40[14]	
24576000	X	X	8000	0'b	0'b	24/48	48	1'b	X	0'b/1'b	X	512000
24576000	X	X	8000	0'b	0'b	24/48	96	0'b	X	0'b/1'b	X	256000
24576000	2048000	X	8000	0'b	1'b	24/48	48	1'b	12	0'b/1'b	1'b	512000
24576000	X	X	16000	0'b	0'b	12/24	24	1'b	X	0'b/1'b	X	1024000
24576000	X	X	16000	0'b	0'b	12/24	48	0'b	X	0'b/1'b	X	512000
24576000	4096000	X	16000	0'b	1'b	12/24	24	1'b	6	0'b/1'b	1'b	1024000
24576000	X	X	24000	0'b	0'b	8/16	16	1'b	X	0'b/1'b	X	1536000
24576000	X	X	24000	0'b	0'b	8/16	32	0'b	X	0'b/1'b	X	768000
24576000	6144000	X	24000	0'b	1'b	8/16	16	1'b	4	0'b/1'b	1'b	1536000
24576000	X	X	32000	0'b	0'b	6/12	12	1'b	X	0'b/1'b	X	2048000
24576000	X	X	32000	0'b	0'b	6/12	24	0'b	X	0'b/1'b	X	1024000
24576000	8192000	X	32000	0'b	1'b	6/12	12	1'b	3	0'b/1'b	1'b	2048000
24576000	X	X	48000	0'b	0'b	4/8	8	1'b	X	0'b/1'b	X	3072000
24576000	X	X	48000	0'b	0'b	4/8	16	0'b	X	0'b/1'b	X	1536000
24576000	12288000	X	48000	0'b	1'b	4/8	8	1'b	2	0'b/1'b	1'b	3072000
22579200	X	X	8018	0'b	0'b	22/44	44	1'b	X	0'b/1'b	X	513163
22579200	X	X	8018	0'b	0'b	22/44	88	0'b	X	0'b/1'b	X	256582
22579200	X	X	11025	0'b	0'b	16/32	32	1'b	X	0'b/1'b	X	705600
22579200	X	X	11025	0'b	0'b	16/32	64	0'b	X	0'b/1'b	X	352800
22579200	2822400	X	11025	0'b	1'b	16/32	32	1'b	8	0'b/1'b	1'b	705600
22579200	X	X	22050	0'b	0'b	8/16	16	1'b	X	0'b/1'b	X	1411200
22579200	X	X	22050	0'b	0'b	8/16	32	0'b	X	0'b/1'b	X	705600
22579200	5644800	X	22050	0'b	1'b	8/16	16	1'b	4	0'b/1'b	1'b	1411200
22579200	X	X	44100	0'b	0'b	4/8	8	1'b	X	0'b/1'b	X	2822400
22579200	X	X	44100	0'b	0'b	4/8	16	0'b	X	0'b/1'b	X	1411200
22579200	11289600	X	44100	0'b	1'b	4/8	8	1'b	2	0'b/1'b	1'b	2822400
13000000	X	24576000	8000	1'b	0'b	24/48	96	0'b	X	0'b/1'b	X	256000
13000000	X	24576000	8000	1'b	0'b	24/48	48	1'b	X	0'b/1'b	X	512000
13000000	X	22579200	11025	1'b	0'b	16/32	32	1'b	X	0'b/1'b	X	705600
13000000	X	22579200	11025	1'b	0'b	16/32	64	0'b	X	0'b/1'b	X	352800
13000000	X	24576000	16000	1'b	0'b	12/24	24	1'b	X	0'b/1'b	X	1024000
13000000	X	24576000	16000	1'b	0'b	12/24	48	0'b	X	0'b/1'b	X	512000
13000000	X	22579200	22050	1'b	0'b	8/16	16	1'b	X	0'b/1'b	X	1411200
13000000	X	22579200	22050	1'b	0'b	8/16	32	0'b	X	0'b/1'b	X	705600
13000000	X	24576000	24000	1'b	0'b	8/16	16	1'b	X	0'b/1'b	X	1536000
13000000	X	24576000	24000	1'b	0'b	8/16	32	0'b	X	0'b/1'b	X	768000
13000000	X	24576000	32000	1'b	0'b	6/12	24	0'b	X	0'b/1'b	X	1024000
13000000	X	22579200	44100	1'b	0'b	4/8	8	1'b	X	0'b/1'b	X	2822400
13000000	X	22579200	44100	1'b	0'b	4/8	16	0'b	X	0'b/1'b	X	1411200
13000000	X	24576000	48000	1'b	0'b	4/8	8	1'b	X	0'b/1'b	X	3072000
13000000	X	24576000	48000	1'b	0'b	4/8	16	0'b	X	0'b/1'b	X	1536000

X ==> Don't Care
- ==> forbidden

MCLK	EXTCLK	PLL	VoDAC Sample Rate	Voice_mclk _sel	Voice_ sysclk_sel	Clk_filter_m aster_div	I2S_sclk_vo ice_master_ div	I2S_wclk_v oice_master_ sel	Extclk_out_ sel	Voice_64osr	Extclk_dir	VBCLK (Output)
				Reg64[15]	Reg64[14]	Reg66[7:4]* Reg66[2:0]	Reg64[7:4]* Reg64[2:0]	Reg64[13]	Reg64[10:8]	Reg66[13]	Reg40[14]	
24576000	X	X	8000	0'b	0'b	24/48	48	1'b	X	0'b/1'b	X	512000
24576000	X	X	8000	0'b	0'b	24/48	96	0'b	X	0'b/1'b	X	256000
24576000	2048000	X	8000	0'b	1'b	24/48	48	1'b	12	0'b/1'b	1'b	512000
24576000	X	X	16000	0'b	0'b	12/24	24	1'b	X	0'b/1'b	X	1024000
24576000	X	X	16000	0'b	0'b	12/24	48	0'b	X	0'b/1'b	X	512000
24576000	4096000	X	16000	0'b	1'b	12/24	24	1'b	6	0'b/1'b	1'b	1024000
24576000	X	X	24000	0'b	0'b	8/16	16	1'b	X	0'b/1'b	X	1536000
24576000	X	X	24000	0'b	0'b	8/16	32	0'b	X	0'b/1'b	X	768000
24576000	6144000	X	24000	0'b	1'b	8/16	16	1'b	4	0'b/1'b	1'b	1536000
24576000	X	X	32000	0'b	0'b	6/12	12	1'b	X	0'b/1'b	X	2048000
24576000	X	X	32000	0'b	0'b	6/12	24	0'b	X	0'b/1'b	X	1024000
24576000	8192000	X	32000	0'b	1'b	6/12	12	1'b	3	0'b/1'b	1'b	2048000
24576000	X	X	48000	0'b	0'b	4/8	8	1'b	X	0'b/1'b	X	3072000
24576000	X	X	48000	0'b	0'b	4/8	16	0'b	X	0'b/1'b	X	1536000
24576000	12288000	X	48000	0'b	1'b	4/8	8	1'b	2	0'b/1'b	1'b	3072000
22579200	X	X	8018	0'b	0'b	22/44	44	1'b	X	0'b/1'b	X	513163
22579200	X	X	8018	0'b	0'b	22/44	88	0'b	X	0'b/1'b	X	256582
22579200	X	X	11025	0'b	0'b	16/32	32	1'b	X	0'b/1'b	X	705600
22579200	X	X	11025	0'b	0'b	16/32	64	0'b	X	0'b/1'b	X	352800
22579200	2822400	X	11025	0'b	1'b	16/32	32	1'b	8	0'b/1'b	1'b	705600
22579200	X	X	22050	0'b	0'b	8/16	16	1'b	X	0'b/1'b	X	1411200
22579200	X	X	22050	0'b	0'b	8/16	32	0'b	X	0'b/1'b	X	705600
22579200	5644800	X	22050	0'b	1'b	8/16	16	1'b	4	0'b/1'b	1'b	1411200
22579200	X	X	44100	0'b	0'b	4/8	8	1'b	X	0'b/1'b	X	2822400
22579200	X	X	44100	0'b	0'b	4/8	16	0'b	X	0'b/1'b	X	1411200
22579200	11289600	X	44100	0'b	1'b	4/8	8	1'b	2	0'b/1'b	1'b	2822400
13000000	X	24576000	8000	1'b	0'b	24/48	96	0'b	X	0'b/1'b	X	256000
13000000	X	24576000	8000	1'b	0'b	24/48	48	1'b	X	0'b/1'b	X	512000
13000000	X	22579200	11025	1'b	0'b	16/32	32	1'b	X	0'b/1'b	X	705600
13000000	X	22579200	11025	1'b	0'b	16/32	64	0'b	X	0'b/1'b	X	352800
13000000	X	24576000	16000	1'b	0'b	12/24	24	1'b	X	0'b/1'b	X	1024000
13000000	X	24576000	16000	1'b	0'b	12/24	48	0'b	X	0'b/1'b	X	512000
13000000	X	22579200	22050	1'b	0'b	8/16	16	1'b	X	0'b/1'b	X	1411200
13000000	X	22579200	22050	1'b	0'b	8/16	32	0'b	X	0'b/1'b	X	705600
13000000	X	24576000	24000	1'b	0'b	8/16	16	1'b	X	0'b/1'b	X	1536000
13000000	X	24576000	24000	1'b	0'b	8/16	32	0'b	X	0'b/1'b	X	768000
13000000	X	24576000	32000	1'b	0'b	6/12	24	0'b	X	0'b/1'b	X	1024000
13000000	X	24576000	32000	1'b	0'b	6/12	12	1'b	3	0'b/1'b	X	2048000
13000000	X	22579200	44100	1'b	0'b	4/8	8	1'b	X	0'b/1'b	X	2822400
13000000	X	22579200	44100	1'b	0'b	4/8	16	0'b	X	0'b/1'b	X	1411200
13000000	X	24576000	48000	1'b	0'b	4/8	8	1'b	X	0'b/1'b	X	3072000
13000000	X	24576000	48000	1'b	0'b	4/8	16	0'b	X	0'b/1'b	X	1536000

X ==> Don't Care
- ==> forbidden

12.2. Slave Mode: (voice_port_sel=1)

MCLK	EXTCLK	PLL	VDAC	VBCLK (Input)	Voice_mclk_sel	Voice_sysclk_sel	Sel_clk_filter	Ck_filter_master_div	I2S_sclk_voice_master_div	I2S_wclk_voice_master_sel	Sel_clk_filter_slave	Extclk_out_sel	Voice_64osr
					Reg64[15]	Reg64[14]	Reg66[14]	Reg66(7-4)* Reg66[2:0]	Reg64(7-4)* Reg64[2:0]	Reg64[13]	Reg66[15]	Reg64[10:8]	Reg66[13]
X	1024000	X	8000	X	0'b	1'b	0'b	-/2	X	X	X	X	-/1'b
X	2048000	X	8000	X	0'b	1'b	0'b	2/4	X	X	X	X	0'b/1'b
X	3072000	X	8000	X	0'b	1'b	0'b	3/6	X	X	X	X	0'b/1'b
X	4096000	X	8000	X	0'b	1'b	0'b	4/8	X	X	X	X	0'b/1'b
X	X	X	8000	1024000 /512000	0'b	X	1'b	X	X	X	0'b	X	0'b/1'b
X	1411200	X	11025	X	0'b	1'b	0'b	-/2	X	X	X	X	-/1'b
X	2822400	X	11025	X	0'b	1'b	0'b	2/4	X	X	X	X	0'b/1'b
X	4233600	X	11025	X	0'b	1'b	0'b	3/6	X	X	X	X	0'b/1'b
X	5644800	X	11025	X	0'b	1'b	0'b	4/8	X	X	X	X	0'b/1'b
X	X	X	11025	1411200 /705600	0'b	X	1'b	X	X	X	0'b	X	0'b/1'b
X	2048000	X	16000	X	0'b	1'b	0'b	-/2	X	X	X	X	-/1'b
X	4096000	X	16000	X	0'b	1'b	0'b	2/4	X	X	X	X	0'b/1'b
X	6144000	X	16000	X	0'b	1'b	0'b	3/6	X	X	X	X	0'b/1'b
X	8192000	X	16000	X	0'b	1'b	0'b	4/8	X	X	X	X	0'b/1'b
X	X	X	16000	2048000 /1024000	0'b	X	1'b	X	X	X	0'b	X	0'b/1'b
X	2822400	X	22050	X	0'b	1'b	0'b	-/2	X	X	X	X	-/1'b
X	5644800	X	22050	X	0'b	1'b	0'b	2/4	X	X	X	X	0'b/1'b
X	8467200	X	22050	X	0'b	1'b	0'b	3/6	X	X	X	X	0'b/1'b
X	11289600	X	22050	X	0'b	1'b	0'b	4/8	X	X	X	X	0'b/1'b
X	X	X	22050	2822400 /1411200	0'b	X	1'b	X	X	X	0'b	X	0'b/1'b
X	3072000	X	24000	X	0'b	1'b	0'b	-/2	X	X	X	X	-/1'b
X	6144000	X	24000	X	0'b	1'b	0'b	2/4	X	X	X	X	0'b/1'b
X	9216000	X	24000	X	0'b	1'b	0'b	3/6	X	X	X	X	0'b/1'b
X	12288000	X	24000	X	0'b	1'b	0'b	4/8	X	X	X	X	0'b/1'b
X	X	X	24000	3072000 /1536000	0'b	X	1'b	X	X	X	0'b	X	0'b/1'b
X	4096000	X	32000	X	0'b	1'b	0'b	-/2	X	X	X	X	-/1'b
X	8192000	X	0.32	X	0'b	1'b	0'b	2/4	X	X	X	X	0'b/1'b
X	12288000	X	32000	X	0'b	1'b	0'b	3/6	X	X	X	X	0'b/1'b
X	16384000	X	32000	X	0'b	1'b	0'b	4/8	X	X	X	X	0'b/1'b
X	X	X	32000	4096000 /2048000	0'b	X	1'b	X	X	X	0'b	X	0'b/1'b
X	5644800	X	44100	X	0'b	1'b	0'b	-/2	X	X	X	X	-/1'b
X	11289600	X	44100	X	0'b	1'b	0'b	2/4	X	X	X	X	0'b/1'b
X	16934400	X	44100	X	0'b	1'b	0'b	3/6	X	X	X	X	0'b/1'b
X	22579200	X	44100	X	0'b	1'b	0'b	4/8	X	X	X	X	0'b/1'b
X	X	X	44100	5644800 /2822400	0'b	X	1'b	X	X	X	0'b	X	0'b/1'b
X	6144000	X	48000	X	0'b	1'b	0'b	-/2	X	X	X	X	-/1'b
X	12288000	X	48000	X	0'b	1'b	0'b	2/4	X	X	X	X	0'b/1'b
X	18432000	X	48000	X	0'b	1'b	0'b	3/6	X	X	X	X	0'b/1'b
X	24576000	X	48000	X	0'b	1'b	0'b	4/8	X	X	X	X	0'b/1'b
X	X	X	48000	6144000 /3072000	0'b	X	1'b	X	X	X	0'b	X	0'b/1'b

X ==> Don't Care

- ==> forbidden

13. Ordering Information

Table 96. Ordering Information

Part Number	Package	Status
ALC5610-GR	QFN-48 in 'Green' Package (Tray)	MP
ALC5610-GRT	QFN-48 in 'Green' Package (Tape & Reel)	MP

Note 1: See page 6 for Green package and version identification.

Note 2: Above parts are tested under AVDD=3.3V.

Realtek Semiconductor Corp.**Headquarters**

No. 2, Innovation Road II

Hsinchu Science Park, Hsinchu 300, Taiwan

Tel.: +886-3-578-0211. Fax: +886-3-557-6047

www.realtek.com.tw