



晶采光電科技股份有限公司
AMPIRE CO., LTD.

SPECIFICATIONS FOR LCD MODULE

CUSTOMER	
CUSTOMER PART NO.	
AMPIRE PART NO.	AM-1024600BTMQW-00H
APPROVED BY	
DATE	

Preliminary Specification



Approved For Specifications & Sample

AMPIRE CO., LTD.

2F., No.88, Sec. 1, Sintai 5th Rd., Sijhih City, Taipei County 221, Taiwan (R.O.C.)

台北縣汐止市新台五路一段 88 號 2 樓(東方科學園區 D 棟)

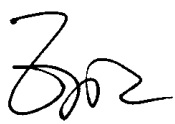
TEL:886-2-26967269 , FAX:886-2-26967196 or 26967270

APPROVED BY	CHECKED BY	ORGANIZED BY
		

RECORD OF REVISION

Revision Date	Page	Contents	Editor
2009/02/02	--	New Release	John

1. Features

10 inch is Amorphous-TFT-LCD (Thin Film Transistor Liquid Crystal Display) module. This module is composed of a 10" TFT-LCD panel, a driving circuit and backlight system. This TFT LCD has a 10 (17:10) inch diagonally measured active display area with WSVGA (1024 horizontal by 600 vertical pixel) resolution.

- (1) Construction: 10" a-Si TFT active matrix, White LED Backlight .
- (2) Resolution (pixel): 1024(R.G.B) X600
- (3) Number of the Colors : 262K colors (R , G , B 6 bit digital each)
- (4) Display mode : Normally White
- (5) Interface: One channel LVDS interface.
- (6) Power Supply Voltage: 3.3V single power input.
- (7) Build-in LED Driver IC. (5.0V Input Voltage).
- (8) Viewing Direction: 6 O'clock.
- (9) RoHS Compliance.

2. PHYSICAL SPECIFICATIONS

Item	Specifications	unit
LCD size	10 inch (Diagonal)	
Resolution	1024 x 3(RGB) x 600	dot
Pixel pitch	0.21525(W) x 0.21525(H)	mm
Active area	220.42(W) x 129.15(H)	mm
Module size	235.0(W) x 145.8(H) x 5.5(D)	mm
Surface treatment	Antiglare, Hard-Coating (3H) with EWV film	
Color arrangement	RGB-stripe	
interface	LVDS	
Weight	253(Typ)	g

3. ABSOLUTE MAX. RATINGS

(GND = AVSS = 0V)

Item	Symbol	Values		UNIT	Note
		Min.	Max.		
Power voltage	V _{LED}	-0.3	6.0	V	
	VDD	-0.3	6.0		
Operation temperature	T _{OP}	-20	70	°C	
Storage temperature	T _{ST}	-30	80	°C	

4. Mechanical Information

Item		Min.	Typ.	Max.	UNIT
Module size	Horizontal	234.5	235	235.5	mm
	Vertical	145.3	145.8	146.3	mm
	Depth	-	5.5	5.8	mm
Weight		-	253	270	g

5. ELECTRICAL CHARACTERISTICS

5-1 Typical Operation Conditions

Item	Symbol	Values			UNIT	Note
		Min.	Typ.	Max.		
Power voltage	VDD	3.0	3.3	3.6	V	Note1
Power Supply Voltage For LED	V _{LED}	4.7	5.0	5.3	V	
Current of power supply	I _{DD}	-	0.3	-	A	VDD=3.3V Black pattern

Note 1: VDD-dip condition :

when $2.7V \leq VDD < 3.0V$, $t_d \leq 10ms$.

$VDD > 3.0V$, VDD-dip condition should be same as VDD-turn-con condition.

5-2 Switching Characteristics for LVDS Receiver

Item	Symbol	Min.	Typ.	Max.	Unit	Condition
Differential Input High Threshold	V _{th}	--	--	100	mV	V _{CM} =1.2V
Differential Input Low Threshold	V _{tl}	-100	--	--	mV	
Input current	I _{IN}	-10	--	+10	uA	
Differential input Voltage	V _{ID}	0.1	--	0.6	V	
Common Mode Voltage Offset	V _{CM}	(V _{ID} /2)	1.25	1.8-0.4-(V _{ID} /2)	V	

5-3 Bit Mapping & Interface Definition

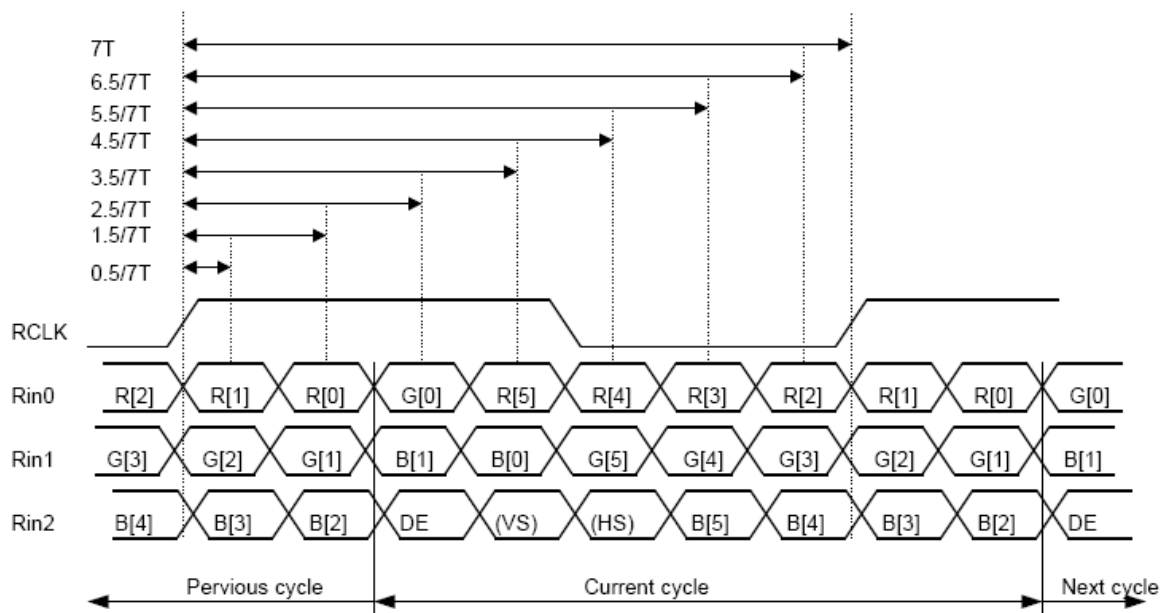

LVDS Receiver Input Timing Definition
for 6bits LVDS input

6. Optical Specifications

Item	Symbol	Condition	Values			Unit	Note
			Min.	Typ.	Max.		
Viewing angle	θL	$(CR \geq 10)$	60	70	--	degree	Note1 Note2
	θR		60	70	--		
	θU		40	50	--		
	θD		50	60	--		
Response time	TR	Normal $\theta = \Phi = 0^\circ$	--	5	7	msec	Note3
	TF		--	20	28	msec	
Contrast ratio	CR		400	500	--	--	Note2
Color chromaticity	WX		0.26	0.31	0.36	--	Note1
	WY		0.28	0.33	0.38	--	Note4
Luminance	L		200	250	--	cd/m ²	Note4
Luminance uniformity	YU		70	--	--	%	Note5

6.1 Measuring surrounding

- dark room
- LED current : $I_L=200\text{mA}$
- Ambient temperature : $25 \pm 2^\circ\text{C}$
- 15min. warm-up time.

6.2 Measuring Equipment

The optical characteristics should be measured in dark room. After 30 minutes operation, the optical properties are measured at the center point of the LCD screen. (Response time is measured by Photo detector TOPCON BM-7 of view : 1° / Height : 120mm.)

Note 1 : Definition of viewing angle range

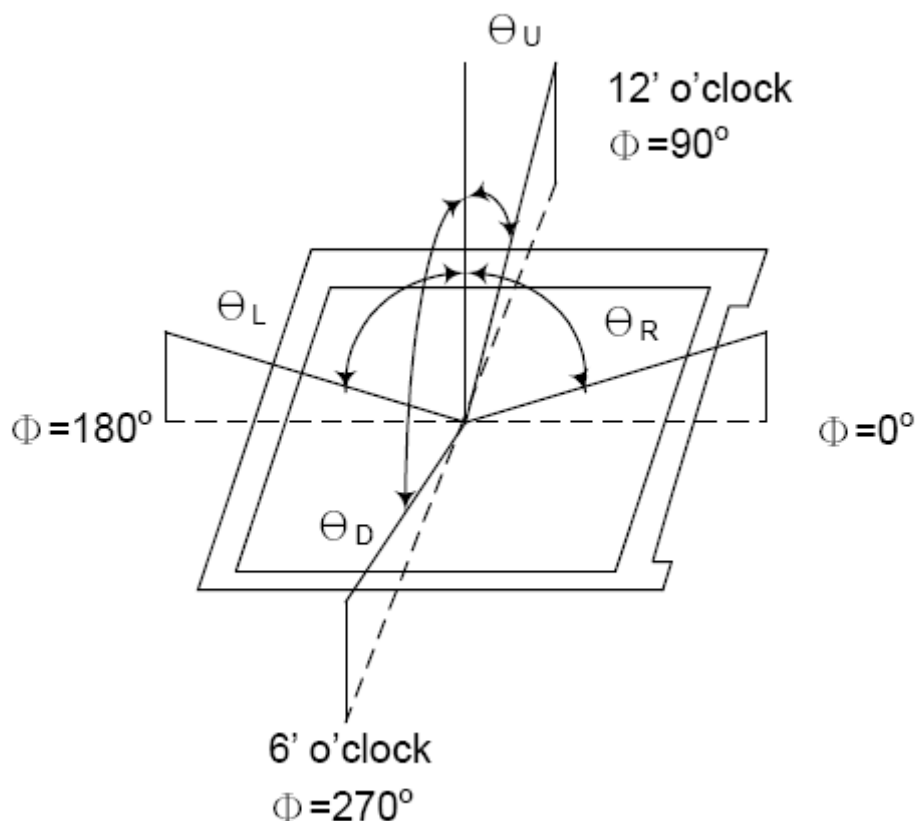

Note 2 : Definition of Contrast Ratio (CR) :

measured at the center point of panel

$$CR = \frac{\text{Luminance with all pixels white}}{\text{Luminance with all pixels black}}$$

Note 3 : Definition of Response time : Sum of T_R and T_F

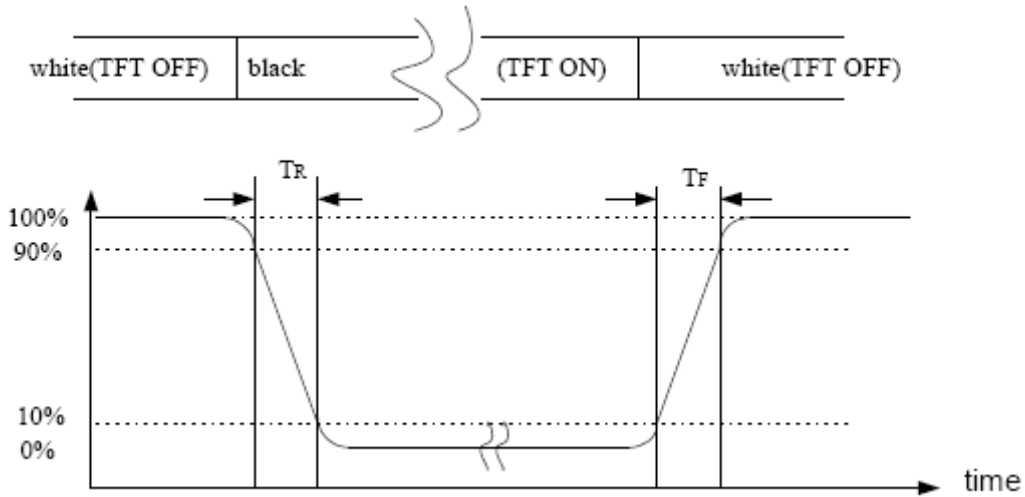

Note 4 : Definition of optical measurement setup

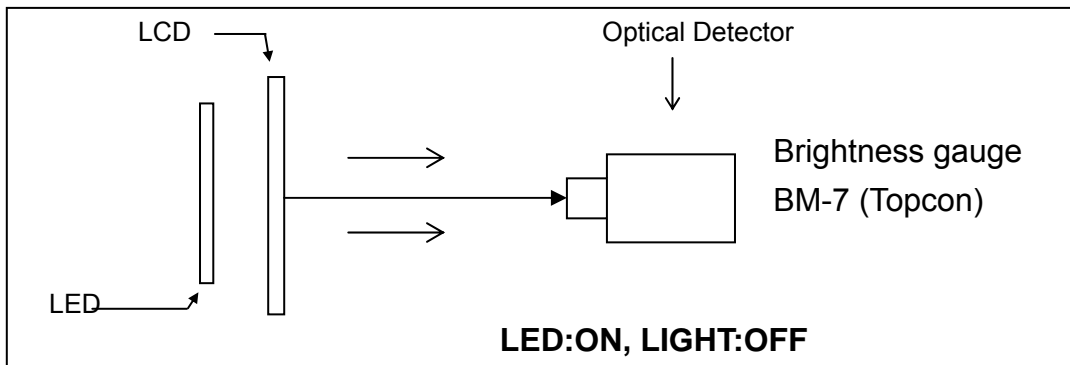

Note 5 : Definition of brightness uniformity

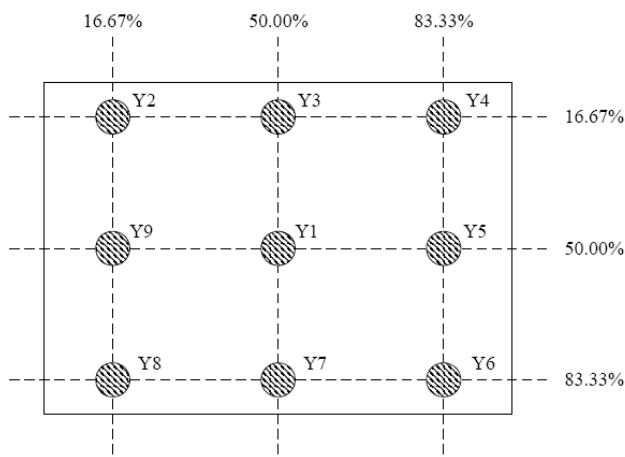

(Min Luminance of 9 points)

$$\text{Luminance uniformity} = \frac{\text{(Min Luminance of 9 points)}}{\text{(Max Luminance of 9 points)}} \times 100\%$$

7. INTERFACE

TFT LCD Panel Driving Section

Pin No.	Symbol	Description	Note
1	GND	Ground	
2	VDD	3.3V Power	
3	VDD	3.3V Power	
4	V_EDID	3.3V Power for EDID	
5	ADJ	Adjust for LED brightness	Note*
6	CLK_EDID	EDID Clock Input	
7	DATA_EDID	EDID Data Input	
8	RXIN0-	LVDS Signal - channel0-	
9	RXIN0+	LVDS Signal+ channel0+	
10	GND	Ground	
11	RXIN1-	Data Input channel1-	
12	RXIN1+	Data Input channel1+	
13	GND	Ground	
14	RXIN2-	Data Input channel2-	
15	RXIN2+	Data Input channel2+	
16	GND	Ground	
17	RXCLKIN-	Data Input CLK-	
18	RXCLKIN+	Data Input CLK+	
19	GND	Ground	
20	NC	NC	
21	NC	NC	
22	GND	Ground	
23	GND	Ground	
24	VLED	VLED Power +5V	
25	VLED	VLED Power +5V	

26	VLED	VLED Power +5V	
27	NC	NC	
28	NC	NC	
29	NC	NC	
30	NC	NC	

Note* : The brightness of LCD panel could be changed by adjusting ADJ

1)ADJ adjust brightness to control Pin. Pulse duty the bigger the brighter.

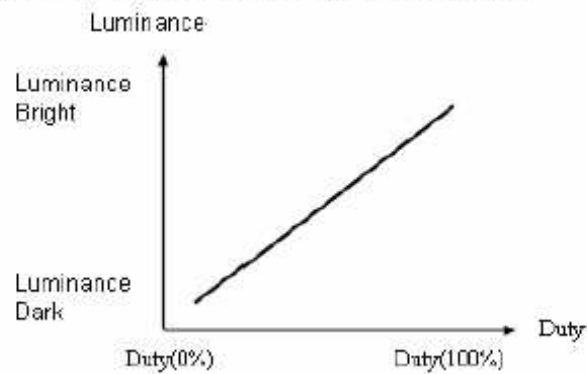

2) ADJ signal=0~3.3V operation frequency:20kHz

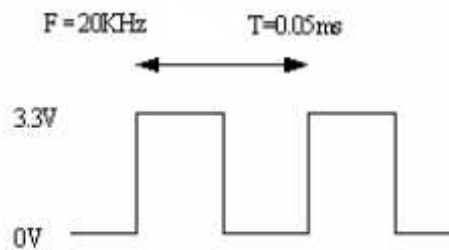

8. BLOCK DIAGRAM :

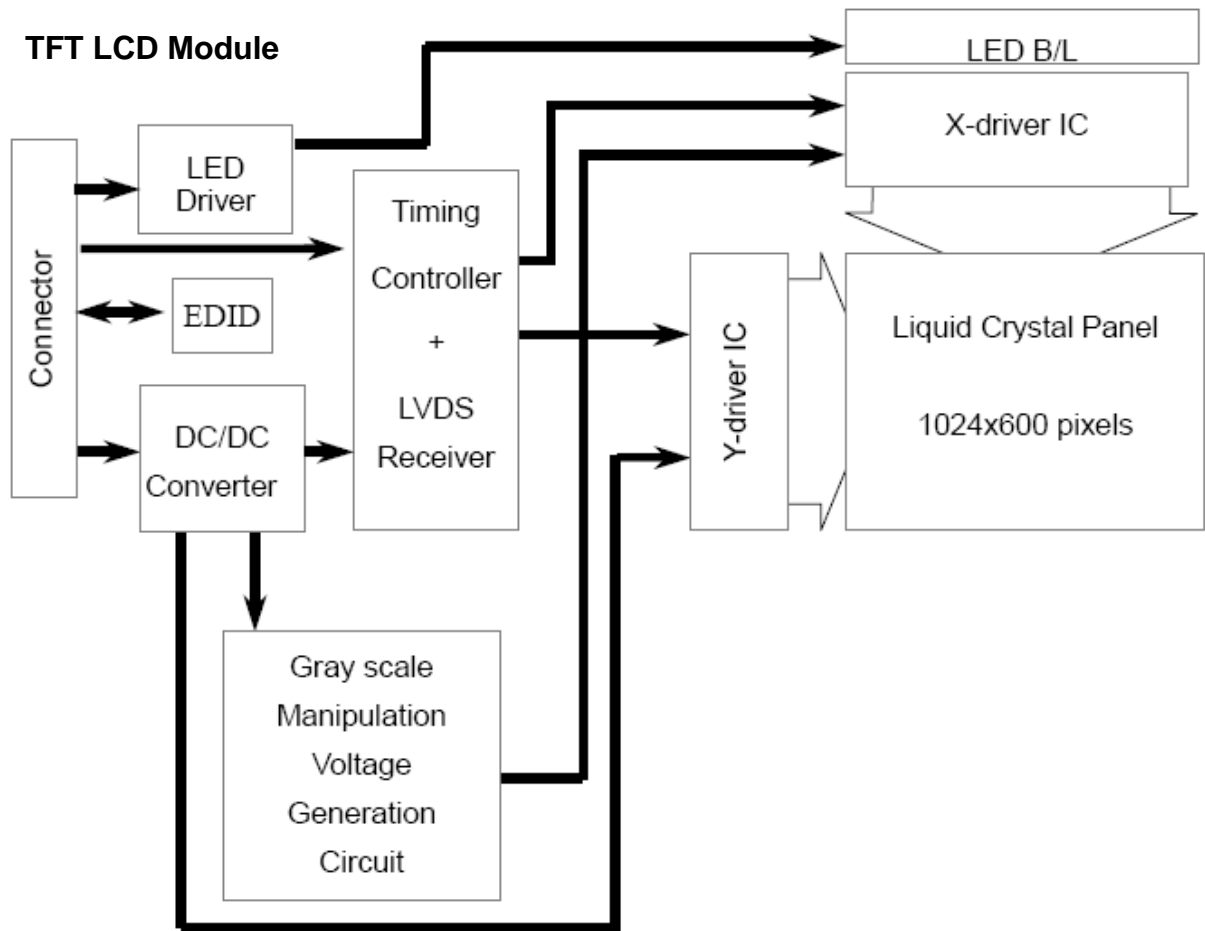

9. Interface Timing (DE mode)

Item	Symbol	Min.	Typ.	Max.	Unit
Frame Rate	--	55	60	65	Hz
Frame Period	t1	612	625	638	line
Vertical Display Time	t2	600	600	600	line
Vertical Blanking Time	t3	12	25	38	line
1 Line Scanning Time	t4	1160	1200	1240	clock
Horizontal Display Time	t5	1024	1024	1024	clock
Horizontal Blanking Time	t6	136	176	216	clock
Clock Rate	t7	39	45	51.42	MHz

Timing Diagram of Interface Signal (DE mode)

(1)Vertical

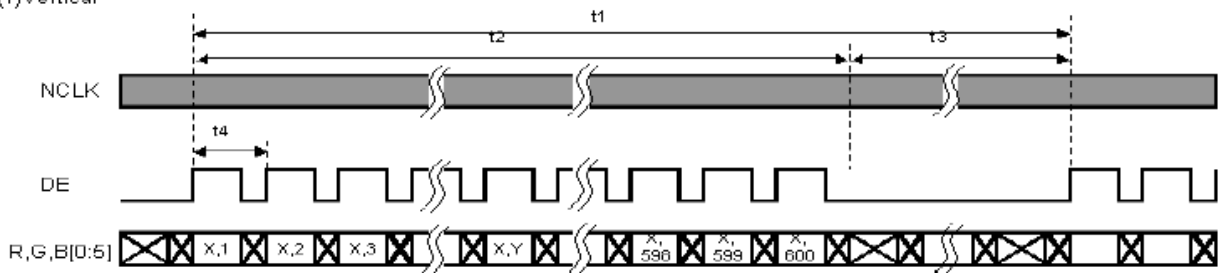

(2)Horizontal

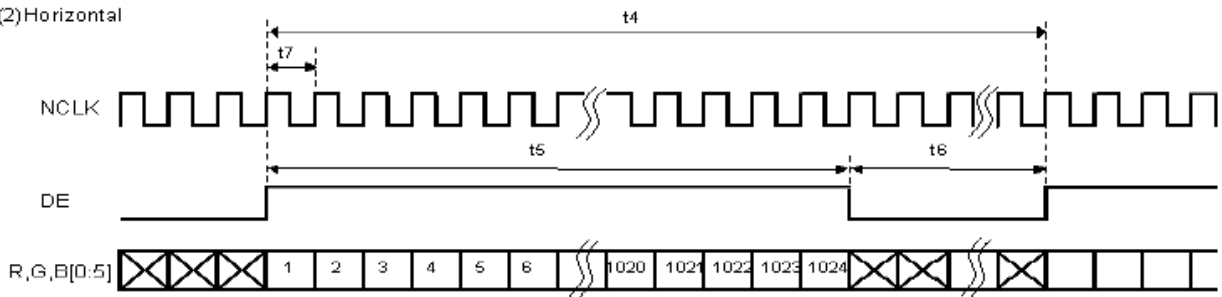

10. Power On/Off Sequence

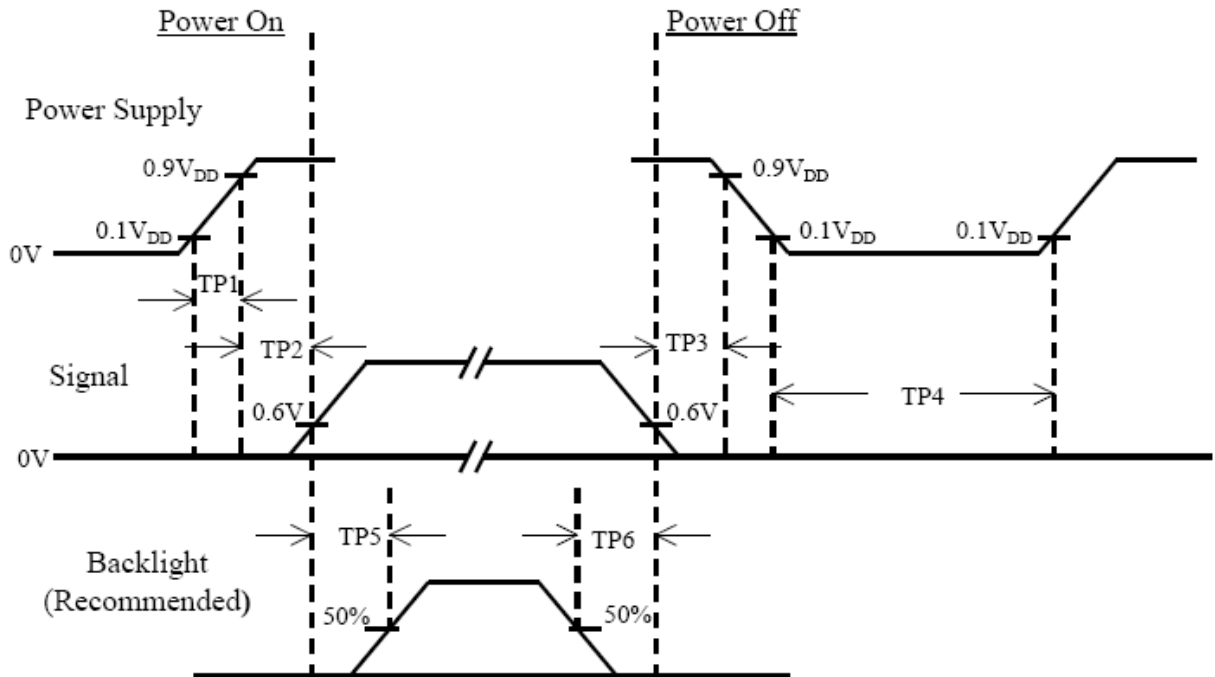

Item	Min.	Typ.	Max.	Unit	Remark
TP1	0.5	--	10	msec	
TP2	0	--	50	msec	
TP3	0	--	50	msec	
TP4	500	--	--	msec	
TP5	200	--	--	msec	
TP6	200	--	--	msec	

Note :

- (1) The supply voltage of the external system for the module input should be the same as the definition of VDD.
- (2) Apply the lamp voltage within the LCD operation range. When the back-light turns on before the LCD operation or the LCD turns off before the back-light turns off, the display may momentarily become white.
- (3) In case of VDD = off level, please keep the level of input signal on the low or keep a high impedance.
- (4) TP4 should be measured after the module has been fully discharged between power off and on period.
- (5) Interface signal shall not be kept at high impedance when the power is on.

11. RELIABILITY TEST CONDITIONS

Item	Test Conditions	Note
High Temperature Storage	Ta = 80°C 240 hrs	
Low Temperature Storage	Ta = -30°C 240 hrs	
High Temperature Operation	Ts = 70°C 240 hrs	
Low Temperature Operation	Ta = -20°C 240 hrs	
Operate at High Temperature and Humidity	+60°C, 90%RH 240 hrs	
Thermal Shock	-30°C /30 min ~ +80°C /30 min 200 cycles	
Vibration Test	1.Random: 1.04G, 10~500Hz, X/Y/Z, 30min/each direction 2.Sine: Freq. Range: 8~33.3Hz Stoke: 1.3mm Sweep: 2.9G, 33.3~400Hz X/Z: 2hr, Y: 4hr, cyc: 15min	
Shock	Half-Sine, 220G, 2ms, ±XYZ, 1time	
Vibration (with carton)	Random Vibration : 0.015G*G/Hz from 5-200HZ, -6dB/Octave from 200-400Hz 2 hours for each direction of X. Y. Z.	
Drop Test(with Carton)	Height : 60 cm 1 comer, 3 edges, 6 surfaces	
Electro Static Discharge	+/-200V,200pF(0Ω) 1 time/connector	

Note: There is no display function NG issue occurred, all the cosmetic specification is judged before the reliability stress.

12. General Precautions

12.1 Use Restriction

This product is not authorized for use in life supporting systems, aircraft navigation control systems, military systems and any other application where performance failure could be life-threatening or otherwise catastrophic.

12.2 Disassembling or Modification

Do not disassemble or modify the module. It may damage sensitive parts inside LCD module, and may cause scratches or dust on the display. Ampire does not warrant the module, if customers disassemble or modify the module.

12.3 Breakage of LCD Panel

- 12.3.1. If LCD panel is broken and liquid crystal spills out, do not ingest or inhale liquid crystal, and do not contact liquid crystal with skin.
- 12.3.2. If liquid crystal contacts mouth or eyes, rinse out with water immediately.
- 12.3.3. If liquid crystal contacts skin or cloths, wash it off immediately with alcohol and rinse thoroughly with water.
- 12.3.4. Handle carefully with chips of glass that may cause injury, when the glass is broken.

12.4 Electric Shock

- 12.4.1. Disconnect power supply before handling LCD module.
- 12.4.2. Do not pull or fold the LED cable.
- 12.4.3. Do not touch the parts inside LCD modules and the fluorescent LED's connector or cables in order to prevent electric shock.

12.5 Absolute Maximum Ratings and Power Protection Circuit

- 12.5.1. Do not exceed the absolute maximum rating values, such as the supply voltage variation, input voltage variation, variation in parts' parameters, environmental temperature, etc., otherwise LCD module may be damaged.
- 12.5.2. Please do not leave LCD module in the environment of high humidity and high temperature for a long time.
- 12.5.3. It's recommended to employ protection circuit for power supply.

12.6 Operation

- 12.6.1 Do not touch, push or rub the polarizer with anything harder than HB pencil lead.
- 12.6.2 Use fingerstalls of soft gloves in order to keep clean display quality, when persons handle the LCD module for incoming inspection or assembly.
- 12.6.3 When the surface is dusty, please wipe gently with absorbent cotton or other soft material.
- 12.6.4 Wipe off saliva or water drops as soon as possible. If saliva or water drops contact with polarizer for a long time, they may causes deformation or color fading.
- 12.6.5 When cleaning the adhesives, please use absorbent cotton wetted with a little petroleum benzine or other adequate solvent.

12.7 Mechanism

Please mount LCD module by using mounting holes arranged in four corners tightly.

12.8 Static Electricity

- 12.8.1 Protection film must remove very slowly from the surface of LCD module to prevent from electrostatic occurrence.
- 12.8.2 Because LCD module use CMOS-IC on circuit board and TFT-LCD panel, it is very weak to electrostatic discharge. Please be careful with electrostatic discharge. Persons who handle the module should be grounded through adequate methods.

12.9 Strong Light Exposure

The module shall not be exposed under strong light such as direct sunlight. Otherwise, display characteristics may be changed.

12.10 Disposal

When disposing LCD module, obey the local environmental regulations.

13. OUTLINE DIMENSION

Unit:mm

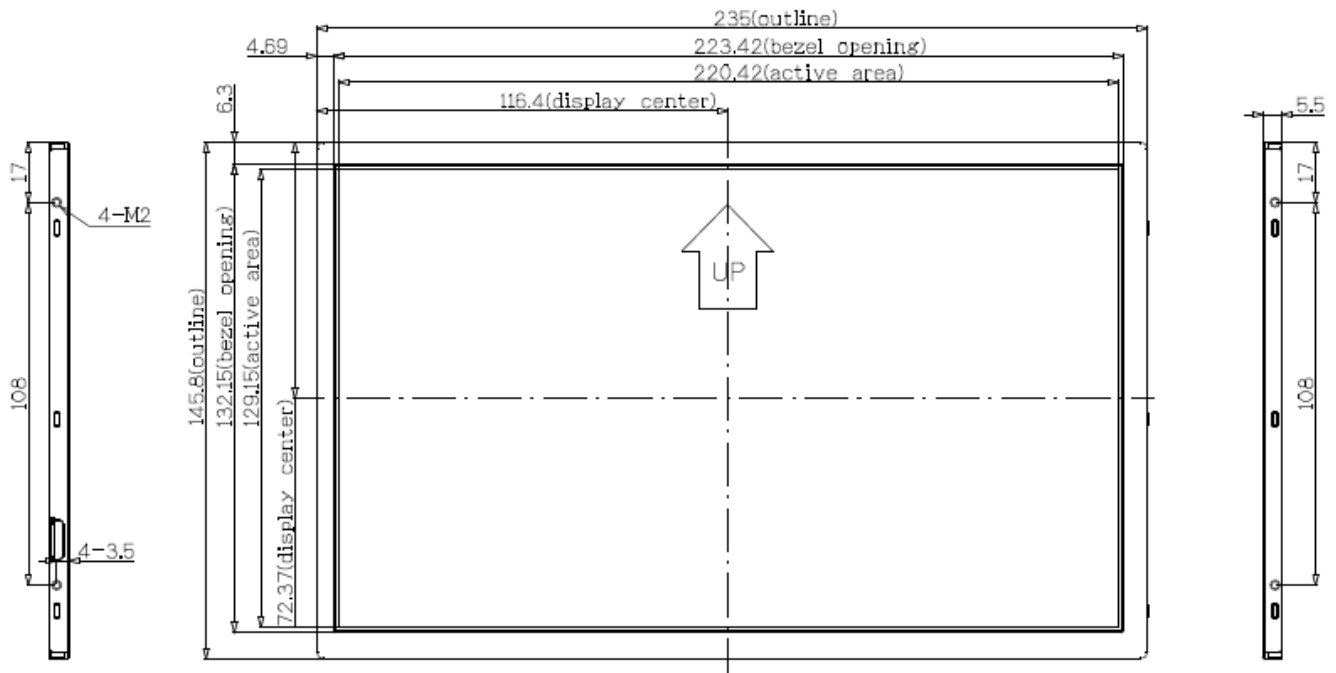

- NOTE:
 1. GENERAL TOLERANCE : $\pm 0.3\text{mm}$
 2. ALLOWED DEPTH OF USERHOLE SCREW INSERTION IS 15mm Max.
 3. USERHOLE SCREW OF TORQUE = 2.0kgf/cm Max.

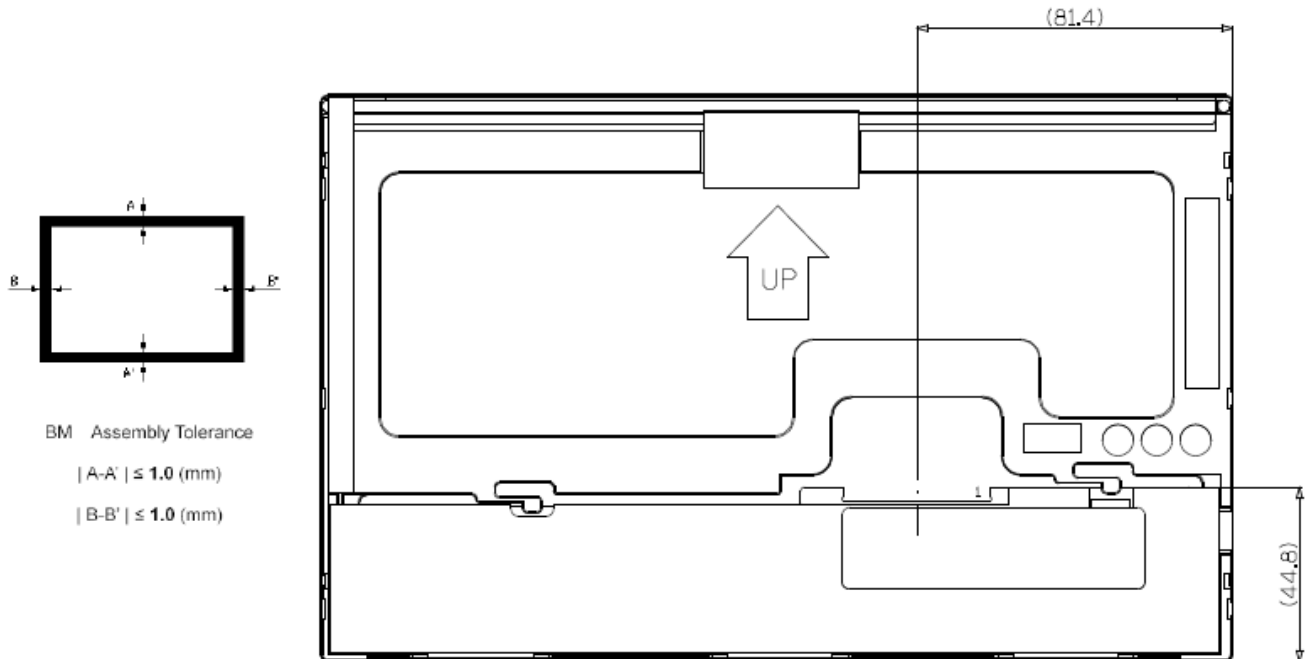

14. EDID TABLE

Byte# (Decimal)	Byte# (HEX)	Field Name & Comments	Value (HEX)	Value (BIN)	Value (DEC)
0	0	Header	00	00000000	0
1	1	Header	FF	11111111	255
2	2	Header	FF	11111111	255
3	3	Header	FF	11111111	255
4	4	Header	FF	11111111	255
5	5	Header	FF	11111111	255
6	6	Header	FF	11111111	255
7	7	Header	00	00000000	0
8	8	EISA Manufacture Code LSB (3 character ID = HSD)	22	00100010	34
9	9	Compressed ASCII	64	01100100	100
10	0A	Product Code "1001"	E9	11101001	233
11	0B	Hex, LSB first	03	00000011	3
12	0C	LCD module Serial No - Preferred but Optional	00	00000000	0
13	0D	LCD module Serial No - Preferred but Optional	00	00000000	0
14	0E	LCD module Serial No - Preferred but Optional	00	00000000	0
15	0F	LCD module Serial No - Preferred but Optional	00	00000000	0
16	10	Week of manufacture=18	12	00010010	18
17	11	Year of manufacture = 2008	12	00010010	18
18	12	EDID Structure Version # = 1	01	00000001	1
19	13	EDID revision # = 3	03	00000011	3
20	14	Video input definition = Digital input, CRGB	80	10000000	128
21	15	Max H image size = 22cm	16	00010110	22
22	16	Max V image size = 13cm	0D	00001101	13
23	17	Display Gamma = 2.2	78	01111000	120
24	18	Feature support (DPMS) = Active off, RGB color	0A	00001010	10
25	19	Red/green low bits (10000110)	86	10000110	134
26	1A	Blue/white low bits (00100110)	26	00100110	38
27	1B	Red x , Red x = 0.58	94	10010100	148
28	1C	Red y , Red y = 0.34	57	01010111	87
29	1D	Green x , Green x = 0.317	51	01010001	81
30	1E	Green y , Green y = 0.564	90	10010000	144
31	1F	Blue x , Blue x = 0.152	27	00100111	39

Byte# (Decimal)	Byte# (HEX)	Field Name & Comments	Value (HEX)	Value (BIN)	Value (DEC)
32	20	Blue y , Blue y = 0.131	21	00100001	33
33	21	White x , White x = 0.31	4F	01001111	79
34	22	White y , White y = 0.33	54	01010100	84
35	23	Established timing 1	00	00000000	0
36	24	Established timing 2	00	00000000	0
37	25	Manufacturer's timings	00	00000000	0
38	26	Standard timing #1 was not used	01	00000001	1
39	27		01	00000001	1
40	28	Standard timing #2 was not used	01	00000001	1
41	29		01	00000001	1
42	2A	Standard timing #3 was not used	01	00000001	1
43	2B		01	00000001	1
44	2C	Standard timing #4 was not used	01	00000001	1
45	2D		01	00000001	1
46	2E	Standard timing #5 was not used	01	00000001	1
47	2F		01	00000001	1
48	30	Standard timing #6 was not used	01	00000001	1
49	31		01	00000001	1
50	32	Standard timing #7 was not used	01	00000001	1
51	33		01	00000001	1
52	34	Standard timing #8 was not used	01	00000001	1
53	35		01	00000001	1
54	36	Detailed timing/monitor (descriptor #1)	94	10010100	148
55	37	1024x600 @60Hz: Pixel Clock = 45 MHz	11	00010001	17
56	38	Horizontal active=1024 pixels (L8b)	00	00000000	0
57	39	Horizontal blanking= 176 pixels (L8b)	B0	10110000	176
58	3A	HA (U4b): HB (U4b)	40	01010000	64
59	3B	Vertical active=600 lines (L8b)	58	01011000	88
60	3C	Vertical blanking= 25 lines (L8b)	19	00011001	25
61	3D	HA (U4b): HB (U4b)	20	00100000	32
62	3E	H sync. Offset= 53 pixels	35	00110101	53
63	3F	H sync. Width= 35 pixels	23	00100011	35

Byte# (Decimal)	Byte# (HEX)	Field Name & Comments	Value (HEX)	Value (BIN)	Value (DEC)
64	40	V sync. Offset= 4 lines	45	01000101	69
65	41	V sync. Width= 5 lines	00	00000000	0
66	42	H image size = 220 mm (L8b)	DC	11011100	220
67	43	V image size = 129 mm (L8b)	81	10000001	129
68	44	Horizontal Image (U4b): Vertical Image (U4b)	00	00000000	0
69	45	No Horizontal Border=0	00	00000000	0
70	46	No Vertical Border=0	00	00000000	0
71	47	Non-interlaced, Normal display, No stereo, Digital separate sync, H/V pol Negatives	19	00011000	25
72	48	Detailed timing/monitor (descriptor #2)	16	00010110	22
73	49	1024x600 @65Hz: Pixel Clock = 51.42 MHz	14	00010100	20
74	4A	Horizontal active=1024 pixels (L8b)	00	00000000	0
75	4B	Horizontal blanking=216pixels (L8b)	D8	11011000	216
76	4C	HA (U4b): HB (U4b)	40	01000000	64
77	4D	Vertical active=600 lines (L8b)	58	01011000	88
78	4E	Vertical blanking= 38 lines (L8b)	26	00100110	38
79	4F	HA (U4b): HB (U4b)	20	00100000	32
80	50	H sync. Offset= 93 pixels	5D	01011101	93
81	51	H sync. Width= 35 pixels	23	00100011	35
82	52	V sync. Offset= 17lines	15	00010101	21
83	53	V sync. Width=5 lines	04	00000100	4
84	54	H image size = 220 mm (L8b)	DC	11011100	220
85	55	V image size = 129 mm (L8b)	81	10000001	129
86	56	Horizontal Image (U4b): Vertical Image (U4b)	00	00000000	0
87	57	No Horizontal Border=0	00	00000000	0
88	58	No Vertical Border=0	00	00000000	0
89	59	EDID Module revision	00	00000000	0
90	5A	Flag	00	00000000	0
91	5B	Flag	00	00000000	0
92	5C	Flag	00	00000000	0
93	5D	Dummy Descriptor	FE	11111110	254
94	5E	Flag	00	00000000	0
95	5F	PC Maker P/N 1 st Character =M	00	00000000	0

Byte# (Decimal)	Byte# (HEX)	Field Name & Comments	Value (HEX)	Value (BIN)	Value (DEC)
96	60	PC Maker P/N 2 nd Character =3	00	00000000	0
97	61	PC Maker P/N 3 rd Character =4	00	00000000	0
98	62	PC Maker P/N 4 th Character =9	00	00000000	0
99	63	PC Maker P/N 5 th Character =5	00	00000000	0
100	64	LCD Supplier EEDID Revision # =1.0	00	00000000	0
101	65	Manufacturer P/N = 1	00	00000000	0
102	66	Manufacturer P/N = 5	00	00000000	0
103	67	Manufacturer P/N = P	00	00000000	0
104	68	Manufacturer P/N = X	00	00000000	0
105	69	Manufacturer P/N = 1	00	00000000	0
106	6A	Manufacturer P/N = 4	00	00000000	0
107	6B	Manufacturer P/N(If <13char, then terminate with ASCII code, set remaining=20h)	00	00000000	0
108	6C	Flag	00	00000000	0
109	6D	Flag	00	00000000	0
110	6E	Flag	00	00000000	0
111	6F	Data Type Tag	FE	11111110	254
112	70	Flag	00	00000000	0
113	71	SMBUS Value = 20 nit	00	00000000	0
114	72	SMBUS Value = 28 nit	00	00000000	0
115	73	SMBUS Value = 40 nit	00	00000000	0
116	74	SMBUS Value = 56 nit	00	00000000	0
117	75	SMBUS Value = 79 nit	00	00000000	0
118	76	SMBUS Value = 111 nit	00	00000000	0
119	77	SMBUS Value = 156 nit	00	00000000	0
120	78	SMBUS Value = max nit	00	00000000	0
121	79	Number of LVDS channels=1	01	00000001	1
122	7A	Panel Self Test (00-Not Present, 01-Present)	00	00000000	0
123	7B	(If<13 char, then terminate with ASCII code 0Ah,set remaining char=20h)	00	00000000	0
124	7C	(If<13 char, then terminate with ASCII code 0Ah,set remaining char=20h)	00	00000000	0
125	7D	(If<13 char, then terminate with ASCII code 0Ah,set remaining char=20h)	00	00000000	0
126	7E	Extension Flag = 00	00	00000000	0
127	7F	Checksum	C8	11001000	200