

A Brighter Solution

AMP DISPLAY INC.

SPECIFICATIONS

CUSTOMER	
CUSTOMER PART NO.	
AMPIRE PART NO.	AM-1024600L2TMQW-00H
APPROVED BY	
DATE	

- Approved For Specifications
- Approved For Specifications & Sample

AMP DISPLAY INC

9856 SIXTH STREET RANCHO CUCAMONGA CA 91730
TEL: 909-980-13410 FAX: 909-980-1419
WWW.AMPDISPLAY.COM

APPROVED BY	CHECKED BY	ORGANIZED BY

RECORD OF REVISION

Revision Date	Page	Contents	Editor
2012/4/12	-	New Release	Rober
2012/4/13	16	Add the CN2 Interface	Rober
	23.24	Correct the OUTLINE DIMENSION	Rober

1. FEATURES

The TFT is a color active matrix TFT LCD module using amorphous silicon TFT's (Thin Film Transistors) as an active switching devices. This module is composed of a TFT LCD panel, a driving circuit and a back light system. This TFT LCD has a 10.1 (17:10) inch diagonally measured active display area with WSVGA(1024 x 600 pixel) resolution.

- (1) 10.1 (17:10 diagonal) inch configuration
- (2) One channel LVDS interface
- (3) 262K color by 6 bit R.G.B signal input
- (4) RoHS Compliance
- (5) Halogen Free

2. PHYSICAL SPECIFICATIONS

Item	Specifications	Unit	Note
LCD size	10.1" (Diagonal)	inch	
Active area	222.72 (H) ×125.28 (V)	mm	
Number of pixels	1024(H) × 600(V)	pixels	
Pixel pitch	0.2715(H) × 0.2088(V)	mm	
Pixel arrangement	RGB Vertical stripe		
Display colors	262,144	colors	
Display mode	Normally white		
Dimensional outline	235.0 (Typ) ×145.8 (Typ) ×8.1(D)	mm	
Back-light	Single LED (Side-Light type)		
Weight	TBD	g	
Surface treatment	Anti-glare		

3. ABSOLUTE MAX. RATINGS

The followings are maximum values which, if exceed, may cause faulty operation or damage to the unit.

Item	Symbol	Values		UNIT	Note
		Min.	Max.		
Logic Supply Voltage	V _{DD}	-0.3	5.0	V	
Operating Temperature	T _{OPA}	-20	70	°C	
Storage Temperature	T _{STG}	-30	80	°C	

4. ELECTRICAL CHARACTERISTICS

4.1 TFT LCD Module

Item	Symbol	Values			UNIT	Note
		Min.	Typ.	Max.		
Power voltage	VDD	3.0	3.3	3.6	V	Note1
Current of power supply	IDD	-	0.3	-	A	VDD=3.3V Black pattern

Note 1: VDD-dip condition :

when $2.7V \leq VDD < 3.0V$, $td \leq 10ms$.

$VDD > 3.0V$, VDD-dip condition should be same as VDD-turn-con condition.

4.2 Switching Characteristics of LVDS Receiver

Item	Symbol	Min.	Typ.	Max.	Unit	Condition
Differential Input High Threshold	VTH	--	--	100	mV	VCM=1.2V
Differential Input Low Threshold	VTL	-100	--	--	mV	
Input current	IIN	-10	--	+10	uA	
Differential input Voltage	VID	0.2	--	0.6	V	
Common Mode Voltage Offset	VCM	$\frac{ VID }{2}$	1.25	$2.4 - \frac{ VID }{2}$	V	

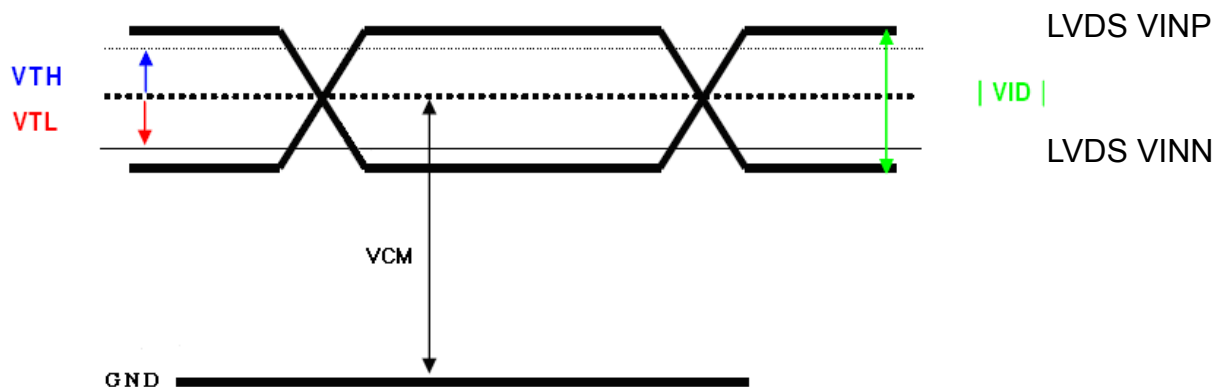

4.3 6-bit LVDS Input Data Mapping

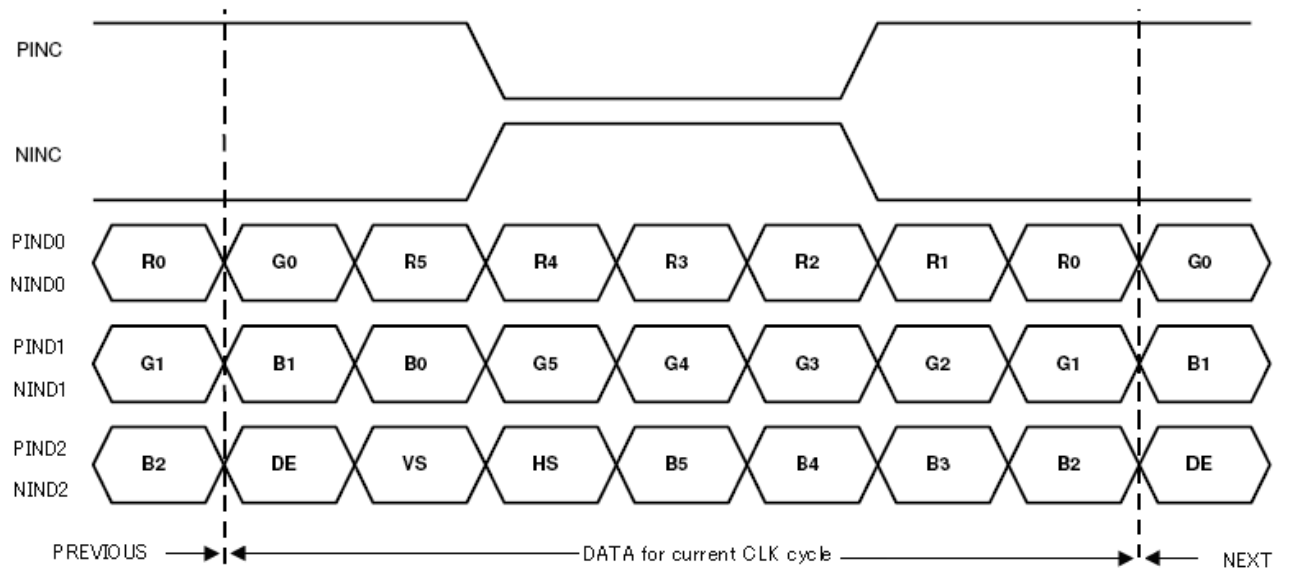

4.4 Timing characteristics of input signals

Item		Symbol	Min.	Typ.	Max.	Unit	
LVDS input signal sequence	Frame Rate	tclk	41	51.2	57	MHz	
LCD input signal sequence (input LVDS Transmitter)	Horizontal	Horizontal total Timing	t _H	1214	1344	1364	tCLK
		Horizontal effective Timing	t _{HA}	1024			tCLK
		Horizontal Blank Time	t _{HB}	190	320	340	tCLK
	Vertical	Vertical total Time	t _V	615	365	645	t _H
		Vertical effective Time	t _{VA}	600			t _H
		Vertical Blank Time	t _{VB}	15	35	45	t _H

Horizontal timing sequence

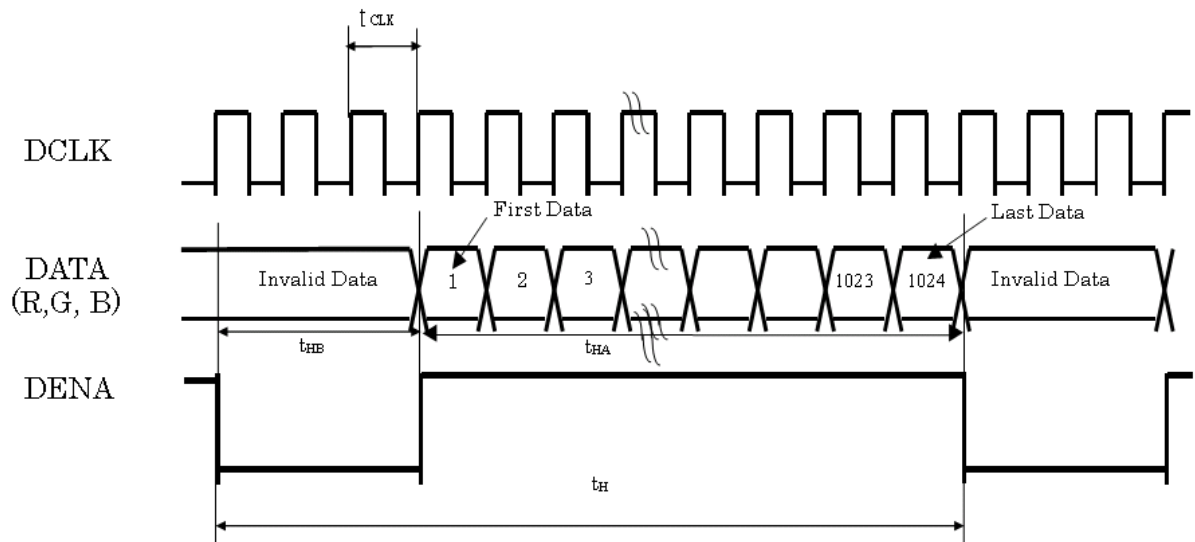

Vertical timing sequence

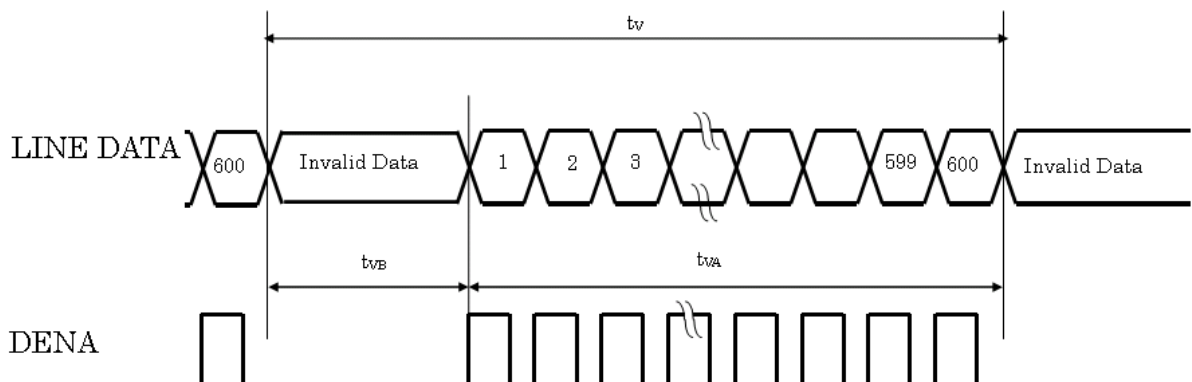

4.5 Backlight Driving Conditions

Item	Symbol	Values			Unit	Note
		Min.	Typ.	Max.		
LED voltage	V _{AK}	--	21	24.6	V	I _L = 480mA T _a = 25°C
LED current	I _L	--	480	--	mA	Note (1)
LED Life Time	-	--	50K	--	Hour	Note (2)

Note (1) : There are 6 Groups LED shown as below , V_{LEDA-LEDK} = 21.0V , T_a = 25°C

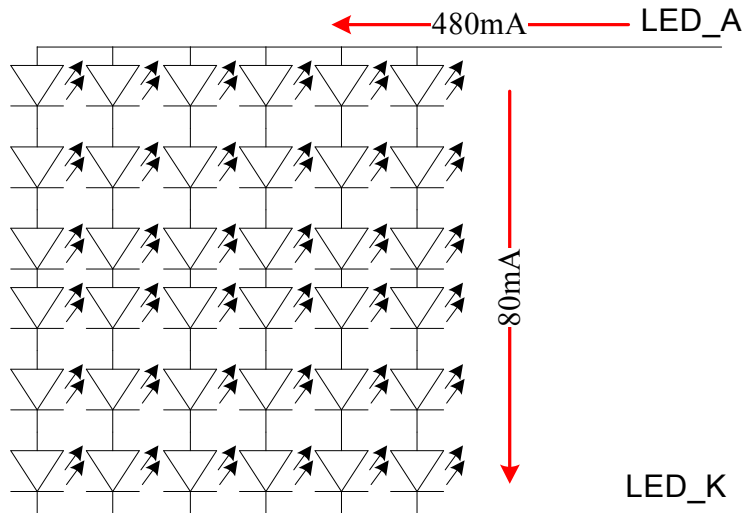

Note2 : Condition: $T_a=25^{\circ}\text{C}$, continuous lighting

Life time is estimated data.

Definitions of failure:

- 1. LCM brightness becomes half of the minimum value.
- 2. LED doesn't light normally.

When LCM is operated over 40°C ambient temperature, the ILED should be follow :

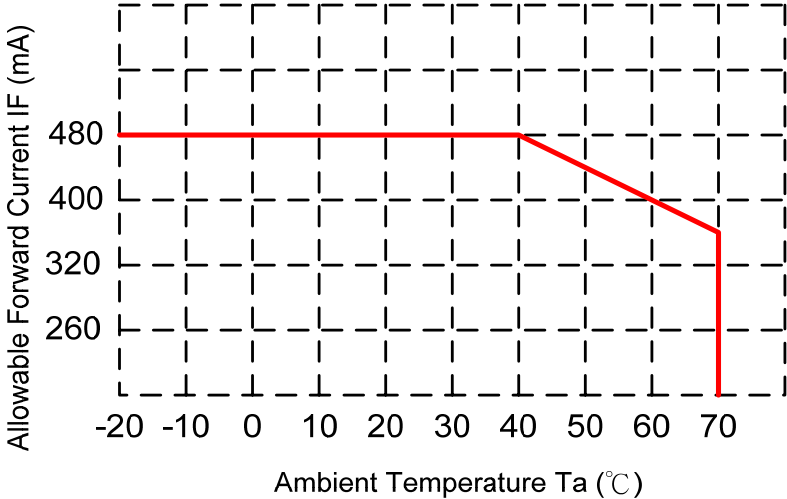

5. OPTICAL SPECIFICATION

5.1 Optical specification

Item	Symbol	Condition	Values			Unit	Note
			Min.	Typ.	Max.		
Viewing angle	θL	$(CR \geq 10)$	60	70	--	degree	Note1 Note2
	θR		60	70	--		
	θU		60	70	--		
	θD		40	50	--		
Response time	TR	Normal $\theta = \Phi = 0^\circ$	--	5	7	msec	Note3
	TF		--	20	28	msec	
Contrast ratio	CR		400	500	--	--	Note2
Color chromaticity	WX		0.26	0.31	0.36	--	Note1 Note4
	WY		0.28	0.33	0.38	--	
	RX		0.54	0.59	0.64	--	
	RY		0.28	0.33	0.38	--	
	GX		0.29	0.34	0.39	--	
	GY		0.54	0.59	0.64	--	
	BX		0.11	0.16	0.21	--	
	BY	0.05	0.1	0.15	--		
Luminance	L	800	1000	--	cd/m ²	Note4	
Luminance uniformity	YU	70	--	--	%	Note5	

5.2 Measuring Condition

- Measuring surrounding : dark room
- Ambient temperature : $25 \pm 2^\circ\text{C}$
- 15min. warm-up time

5.2 Measuring Equipment

The optical characteristics should be measured in dark room. After 30 minutes operation, the optical properties are measured at the center point of the LCD screen. (Response time is measured by Photo detector TOPCON BM-7 of view : 1° / Height : 120mm.)

Note 1 : Definition of viewing angle range

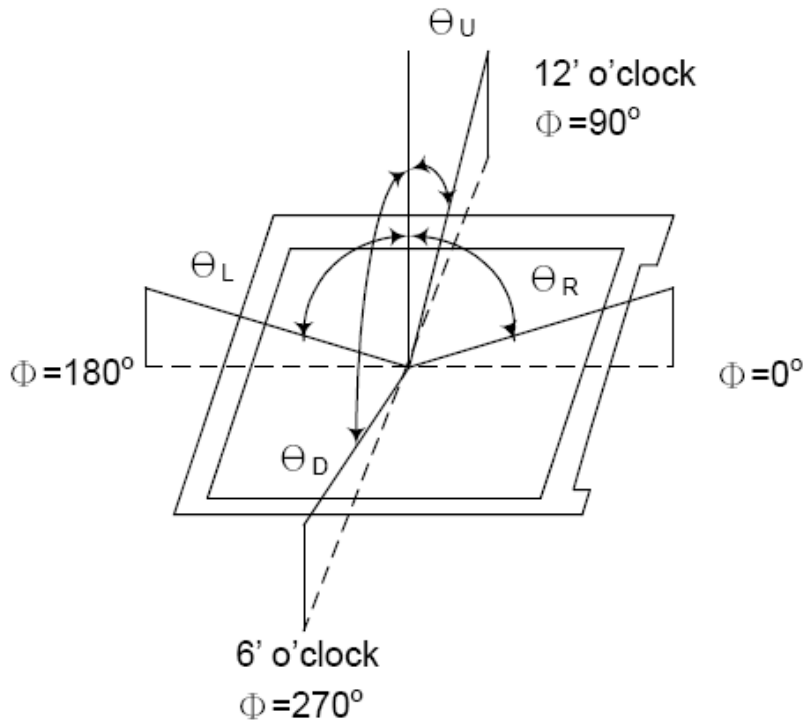

Note 2 : Definition of Contrast Ratio (CR) :
measured at the center point of panel

$$CR = \frac{\text{Luminance with all pixels white}}{\text{Luminance with all pixels black}}$$

Note 3 : Definition of Response time : Sum of Tr and T

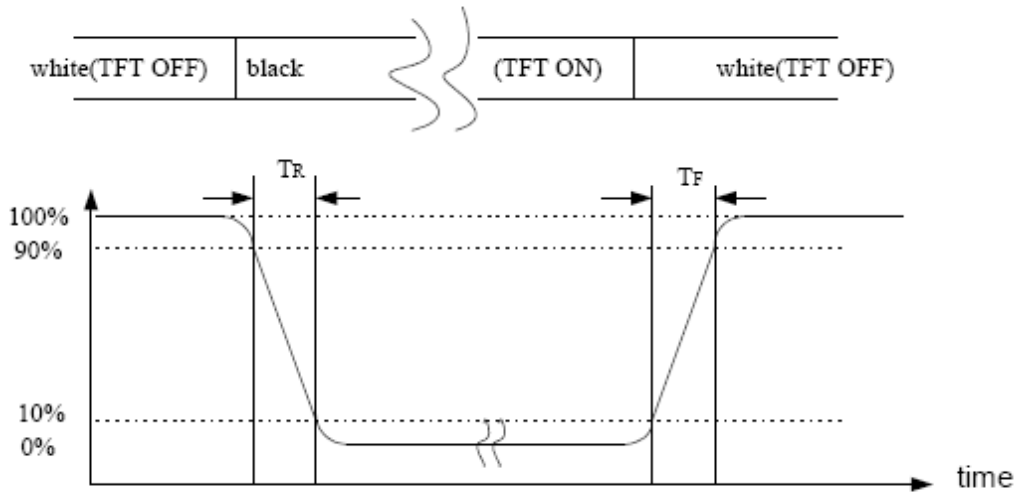

Note 4 : Definition of optical measurement setup

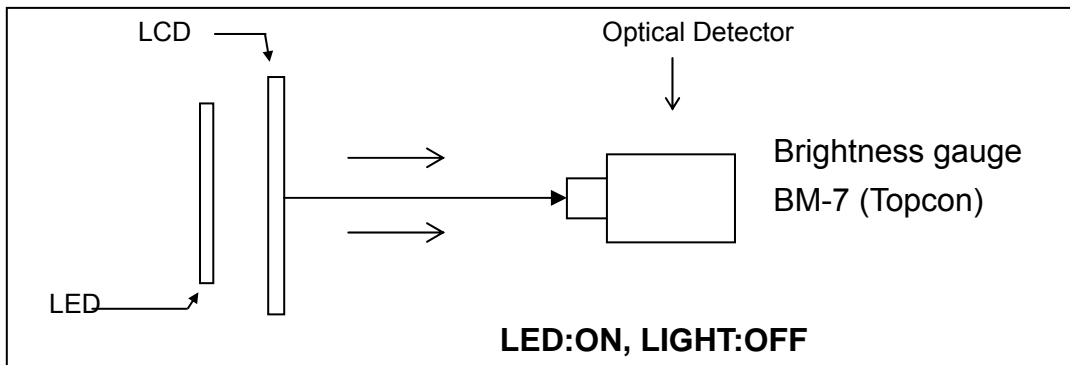

Note 5 : Definition of brightness uniformity

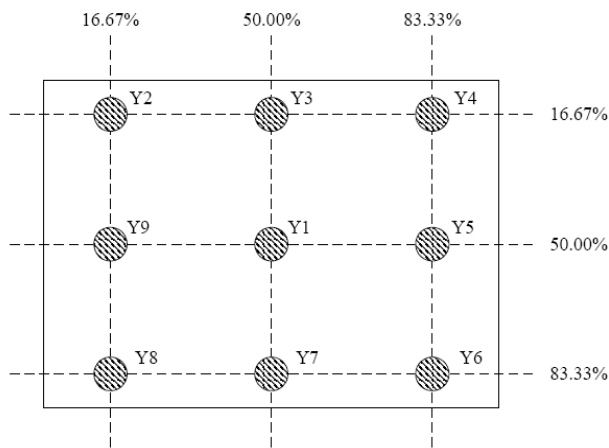

(Min Luminance of 9 points)

$$\text{Luminance uniformity} = \frac{\text{Min Luminance of 9 points}}{\text{Max Luminance of 9 points}} \times 100\%$$

Note 6 : Rubbing Direction (The different Rubbing Direction will cause the different optima view direction)

Note 7 : Condition: $T_a=25^{\circ}\text{C}$, Life time is estimated data.

Definitions of failure:

- i. LCM brightness becomes half of the minimum value.
- ii. LED doesn't light normally.

6. BLOCK DIAGRAM

6.1 TFTLCD Module

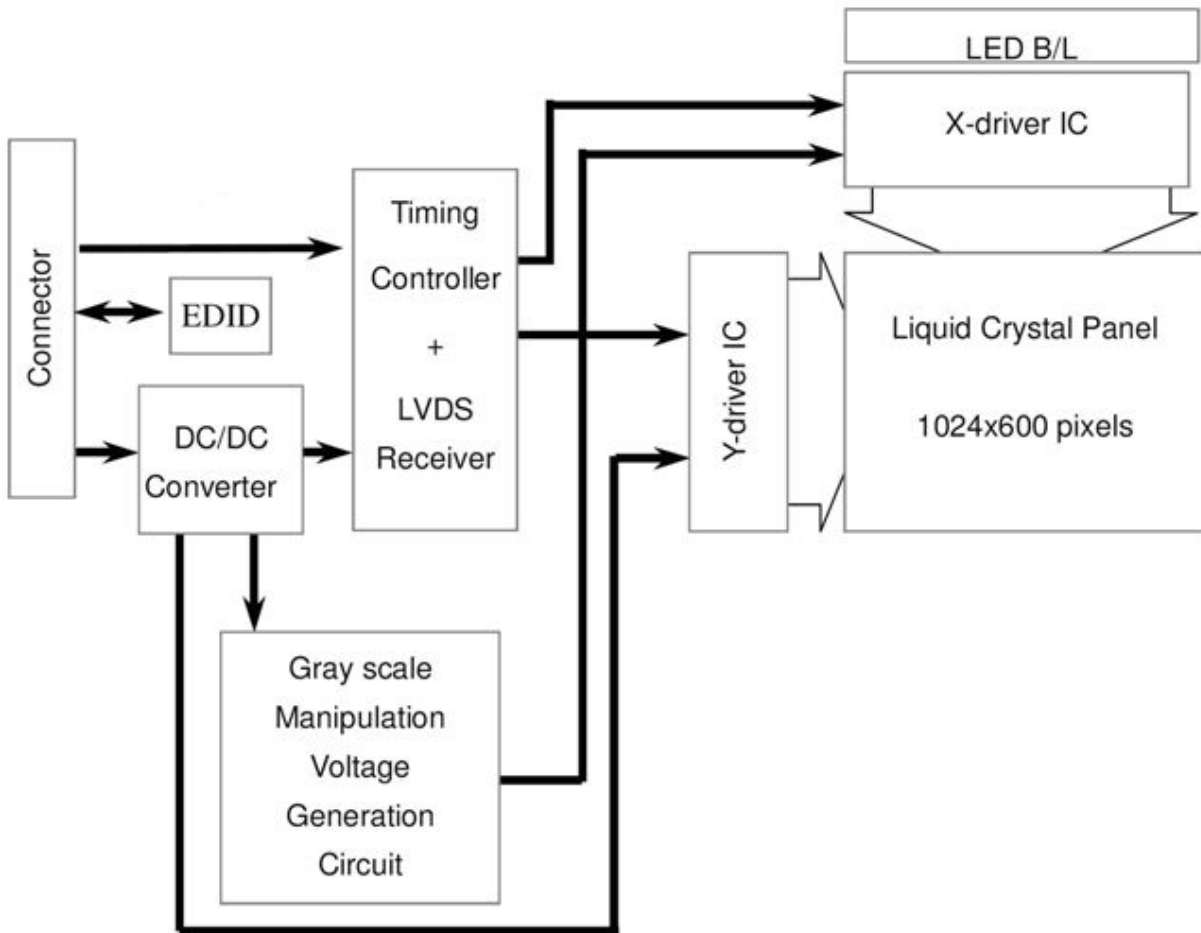

6.2 Pixel format

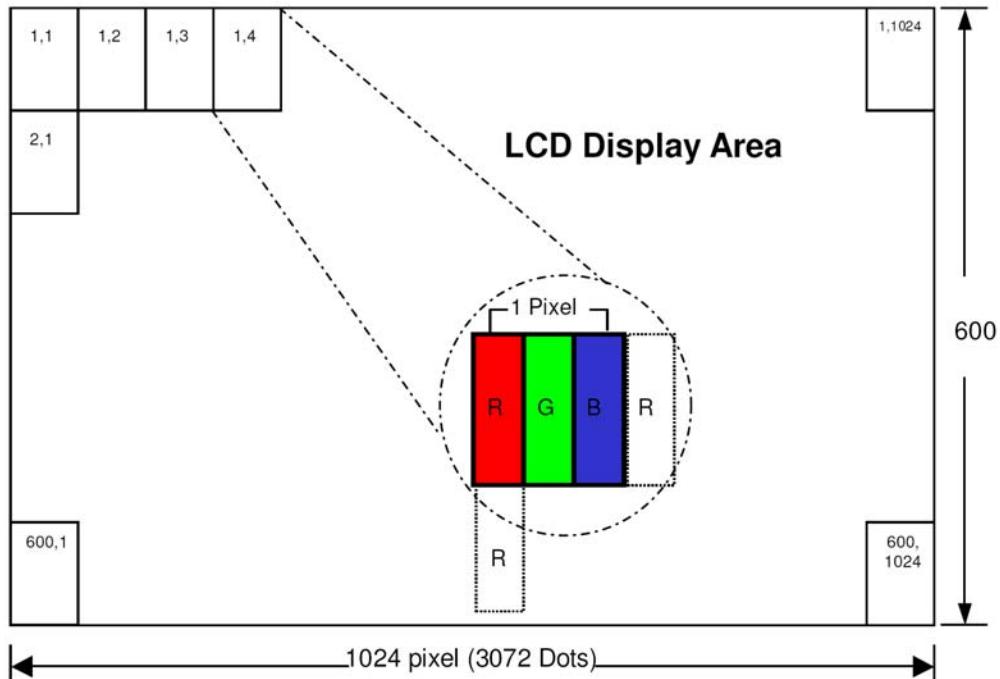

7.INTERFACE

7.1 Electrical Interface Connection

CN1(Input signal): CSTAR DS100-430-H23 (equivalent JAE FI-XB30SSRL-HF16)

Pin No.	Symbol	Description	Note
1	GND	Ground	
2	VDD	3.3V Power	
3	VDD	3.3V Power	
4	V_EDID	3.3V Power for EDID	
5	NC	No connection	
6	CLK_EDID	EDID Clock Input	
7	DATA_EDID	EDID Data Input	
8	RXIN0-	LVDS Signal - channel0-	
9	RXIN0+	LVDS Signal+ channel0+	
10	GND	Ground	
11	RXIN1-	Data Input channel1-	
12	RXIN1+	Data Input channel1+	
13	GND	Ground	
14	RXIN2-	Data Input channel2-	
15	RXIN2+	Data Input channel2+	
16	GND	Ground	
17	RXCLKIN-	Data Input CLK-	
18	RXCLKIN+	Data Input CLK+	
19	GND	Ground	
20	NC	No connection	
21	NC	No connection	
22	GND	Ground	
23	GND	Ground	
24	NC	No connection	

25	NC	No connection	
26	NC	No connection	
27	NC	No connection	
28	NC	No connection	
29	NC	No connection	
30	NC	No connection	

CN2(LED backlight): BHSR-02VS-1 (JST or equivalent)

Pin No.	Symbol	Description	Note
1	A	Anode for LED backlight (+21V, 480mA)	
2	K	Cathode for LED backlight	

(3) LVDS Connector : CSTAR DS100-430-H23

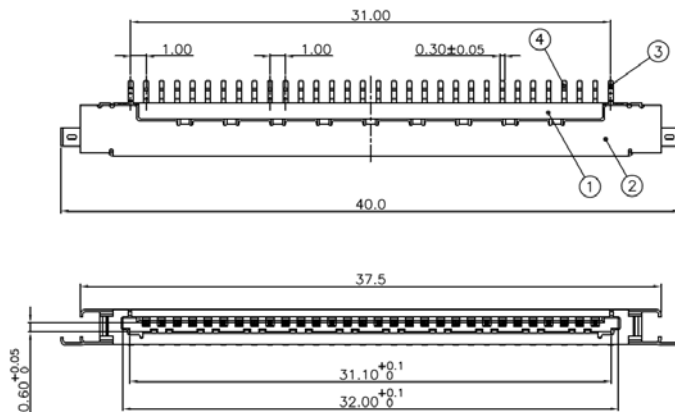

NOTES:
 1.INSULATOR:THERMOPLASTIC;COLOR:BEIGE
 2.CONTACT:COPPER ALLOY t=0.15mm
 PLATING:CONTACT AREA 5u?GOLD,
 SOLDER AREA 80~120u" TIN (LEAD FREE),
 OVERALL WITH 50u?NICKEL UNDER PLATED.
 3.SHELL: STAINLESS t=0.15mm
 PLATING:SOLDER AREA PLATED WITH GOLD FLASH
 4.GROUND: COPPER ALLOY t=0.15mm
 PLATING:TIN(LEAD FREE).
 ELECTRICAL:
 VOLTAGE RATING:200V AC(RMS)/DC
 CURRENT RATING:1A AC(RMS)/DC
 CONTACT RESISTANCE:40mΩ Max.
 INSULATION RESISTANCE:100MΩ Min.
 DIELECTRIC WITHSTANDING VOLTAGE:500V AC(RMS)
 OPERTING TEMPERATURE:-40°C~+80°C

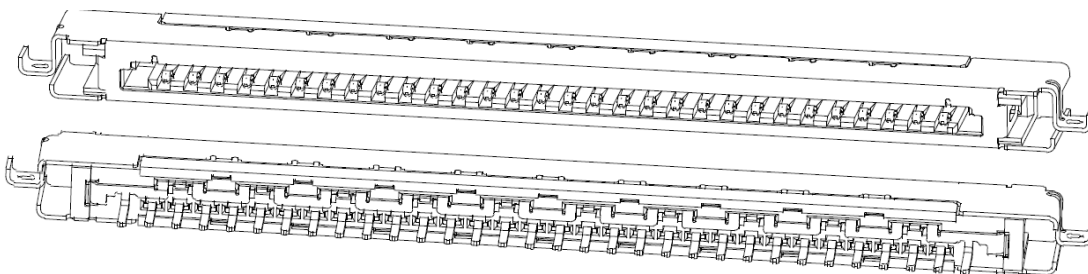

DS100-430-H23
BOTTOM MOUNT

8. Power On/Off Sequence

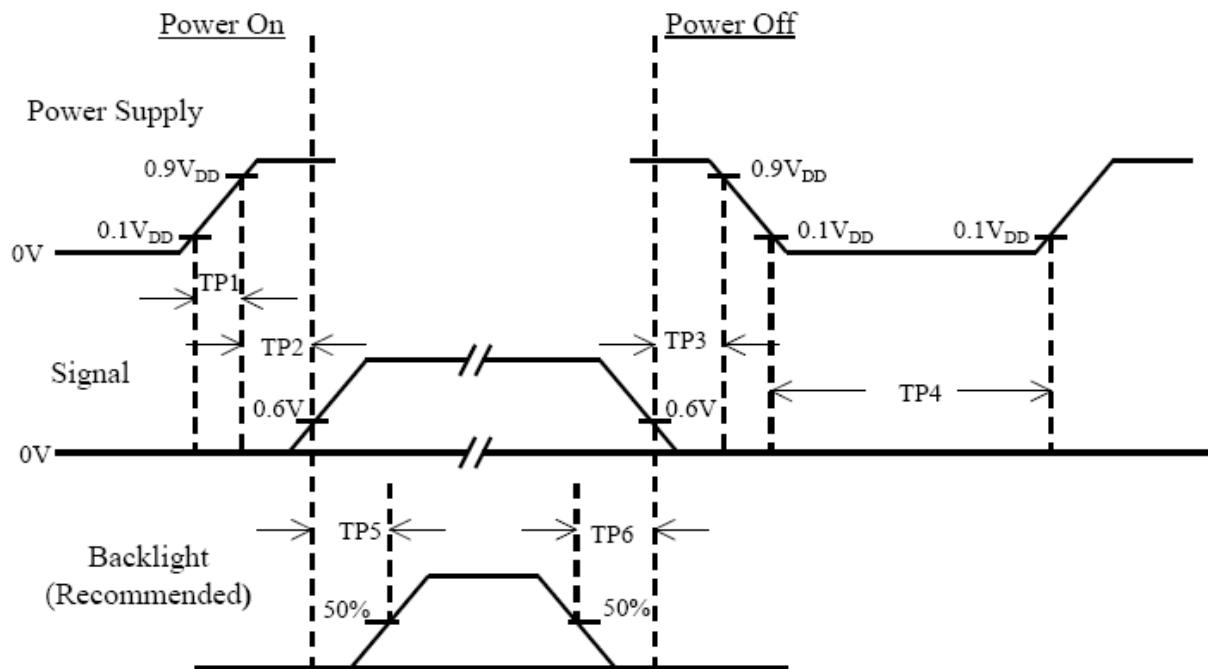

Item	Min.	Typ.	Max.	Unit	Remark
TP1	0.5	--	10	msec	
TP2	0	--	50	msec	
TP3	0	--	50	msec	
TP4	500	--	--	msec	
TP5	200	--	--	msec	
TP6	200	--	--	msec	

Note :

- (1) The supply voltage of the external system for the module input should be the same as the definition of VDD.
- (2) Apply the lamp voltage within the LCD operation range. When the back-light turns on before the LCD operation or the LCD turns off before the back-light turns off, the display may momentarily become white.
- (3) In case of VDD = off level, please keep the level of input signal on the low or keep a high impedance.
- (4) TP4 should be measured after the module has been fully discharged between power off and on period.
- (5) Interface signal shall not be kept at high impedance when the power is on.

9. RELIABILITY TEST CONDITIONS

Item	Test Conditions	Note
High Temperature Storage	Ta = 80°C 240 hrs	
Low Temperature Storage	Ta = -30°C 240 hrs	
High Temperature Operation	Ts = 70°C 240 hrs	
Low Temperature Operation	Ta = -20°C 240 hrs	
Thermal Shock	-30°C /30 min ~ +80°C /30 min 100 cycles	

Storage / Operating temperature

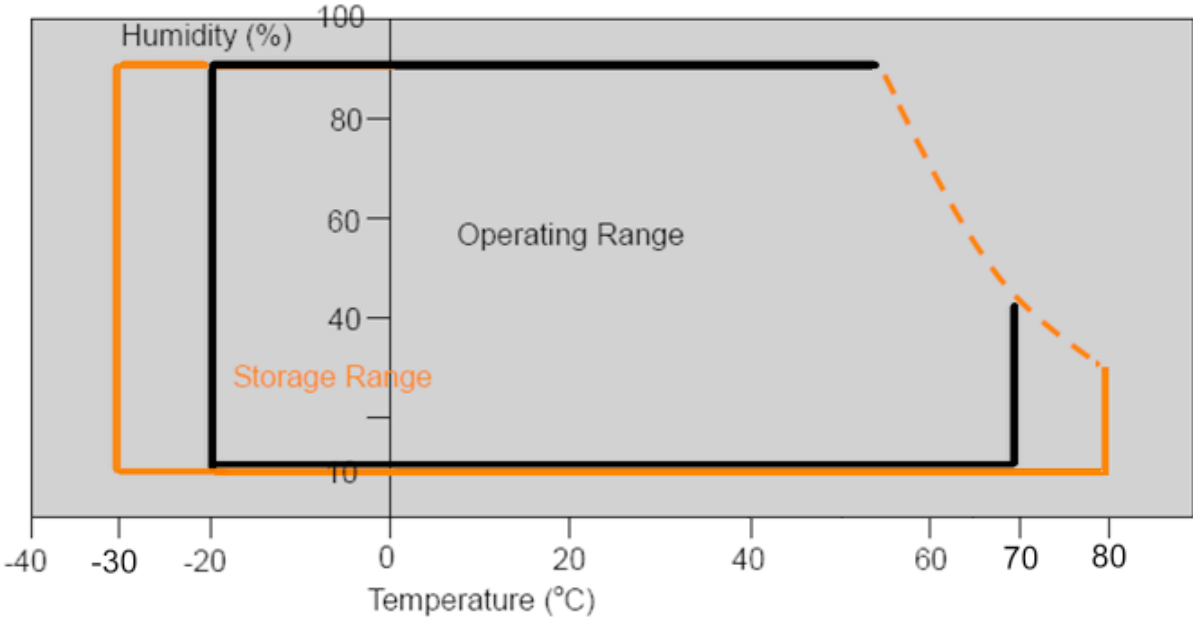

Note .Max wet bulb temp.=39°C

10.INCOMING INSEPTION STANDARDS

10.1. Scope

Specifications contain

10.1.1 Display Quality Evaluation

10.1.2 Mechanics Specification

10.2. Sampling Plan

Unless there is other agreement, the sampling plan for incoming inspection shall follow MIL-STD-105E LEVEL II.

10.2.1 Lot size: Quantity per shipment as one lot (different model as different lot).

10.2.2 Sampling type: Normal inspection, single sampling.

10.2.3 Sampling level: Level II.

10.2.4 AQL: Acceptable Quality Level

Major defect: AQL=0.65

Minor defect: AQL=1.0

10.3. Panel Inspection Condition

10.3.1 Environment:

Room Temperature: $25\pm 5^{\circ}\text{C}$.

Humidity: $65\pm 5\%$ RH.

Illumination: 300 ~ 700 Lux.

10.3.2 Inspection Distance:

35-40 cm

10.3.3 Inspection Angle:

The vision of inspector should be perpendicular to the surface of the Module.

10.3.4 Inspection time :

Perceptibility Test Time: 20 seconds max.

10.4. Display Quality

10.4.1 Function Related:

The function defects of line defect, abnormal display, and no display are considered Major defects.

10.4.2 Bright/Dark Dots:

Defect Type / Specification	G0 Grade	A Grade
Bright Dots	0	$N \leq 3$
Dark Dots	0	$N \leq 4$
Total Bright and Dark Dots	0	$N \leq 6$

[Note 1]

Judge defect dot and adjacent dot as following.

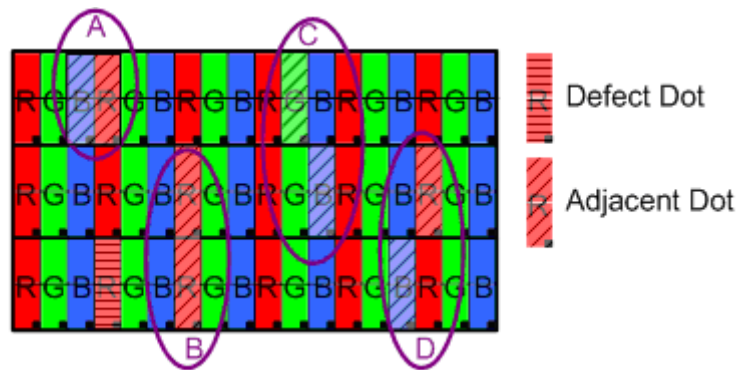

- (1) One pixel consists of 3 sub-pixels, including R,G, and B dot.(Sub-pixel = Dot)
- (2) The definition of dot: The size of a defective dot over 1/2 of whole dot is regarded as one defective dot.
- (3) Allow above (as A, B, C and D status) adjacent defect dots, including bright and dark adjacent dot. And they will be counted 2 defect dots in total quantity.
- (4) Defects on the Black Matrix, out of Display area, are not considered as a defect or counted.
- (5) There should be no distinct non-uniformity visible through 3% ND Filter within 2 sec inspection times.

10.4.3 Visual Inspection specifications:

Defect Type	Specification	Count(N)
Dot Shape (Particle, Scratch and Bubbles in display area)	D 0.25mm	Ignored
	0.25mm < D 0.5mm	$N \leq 3$
	D > 0.5mm	N=0
Line Shape	W 0.07mm	Ignored

(Particles, Scratch, Lint and Bubbles in display area)	0.07mm < W	0.1mm, L	5mm	N ≤ 3
	W > 0.1mm, L > 5mm			N = 0

[Note 2] W : Width[mm], L : Length[mm], N : Number, φ : Average Diameter

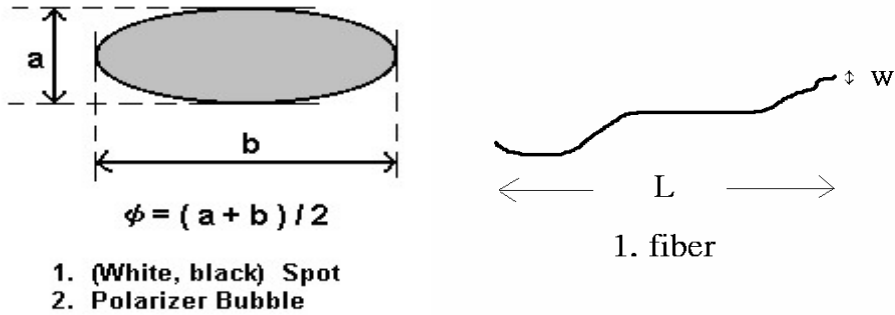

[Note 3] Bright dot is defined through 3% transmission ND Filter as following.

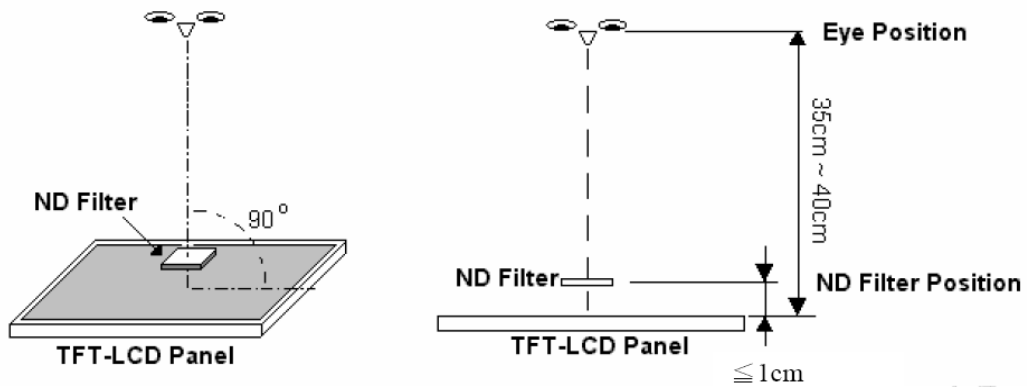

11. HANDLING & CAUTIONS

11.1 Cautions when taking out the module

Pick the pouch only, when taking out module from a shipping package.

11.2 Cautions for handling the module

11.2.1 As the electrostatic discharges may break the LCD module, handle the LCD module with care. Peel a protection sheet off from the LCD panel surface as slowly as possible.

11.2.2 As the LCD panel and backlight element are made from fragile glass material, impulse and pressure to the LCD module should be avoided.

11.2.3 As the surface of the polarizer is very soft and easily scratched, use a soft dry cloth without chemicals for cleaning.

11.2.4 Do not pull the interface connector in or out while the LCD module is operating.

11.2.5 Put the module display side down on a flat horizontal plane.

11.2.6 Handle connectors and cables with care.

11.3 Cautions for the operation

11.3.1 When the module is operating, do not lose MCLK, DE signals. If any one of these signals were lost, the LCD panel would be damaged.

11.3.2 Obey the supply voltage sequence. If wrong sequence were applied, the module would be damaged.

11.4 Cautions for the atmosphere

11.4.1 Dewdrop atmosphere should be avoided.

11.4.2 Do not store and/or operate the LCD module in a high temperature and/or humidity atmosphere. Storage in an electro-conductive polymer-packing pouch and under relatively low temperature atmosphere is recommended.

11.5 Cautions for the module characteristics

11.5.1 Do not apply fixed pattern data signal to the LCD module at product aging.

11.5.2 Applying fixed pattern for a long time may cause image sticking.

11.6 Other cautions

11.6.1 Do not disassemble and/or re-assemble LCD module.

11.6.2 Do not re-adjust variable resistor or switch etc.

11.6.3 When returning the module for repair or etc, please pack the module not to be broken. We recommend using the original shipping packages.

11.6.4 AMIPRE will provide one year warrantee for all products and three months warrantee for all repairing products.

12. OUTLINE DIMENSION

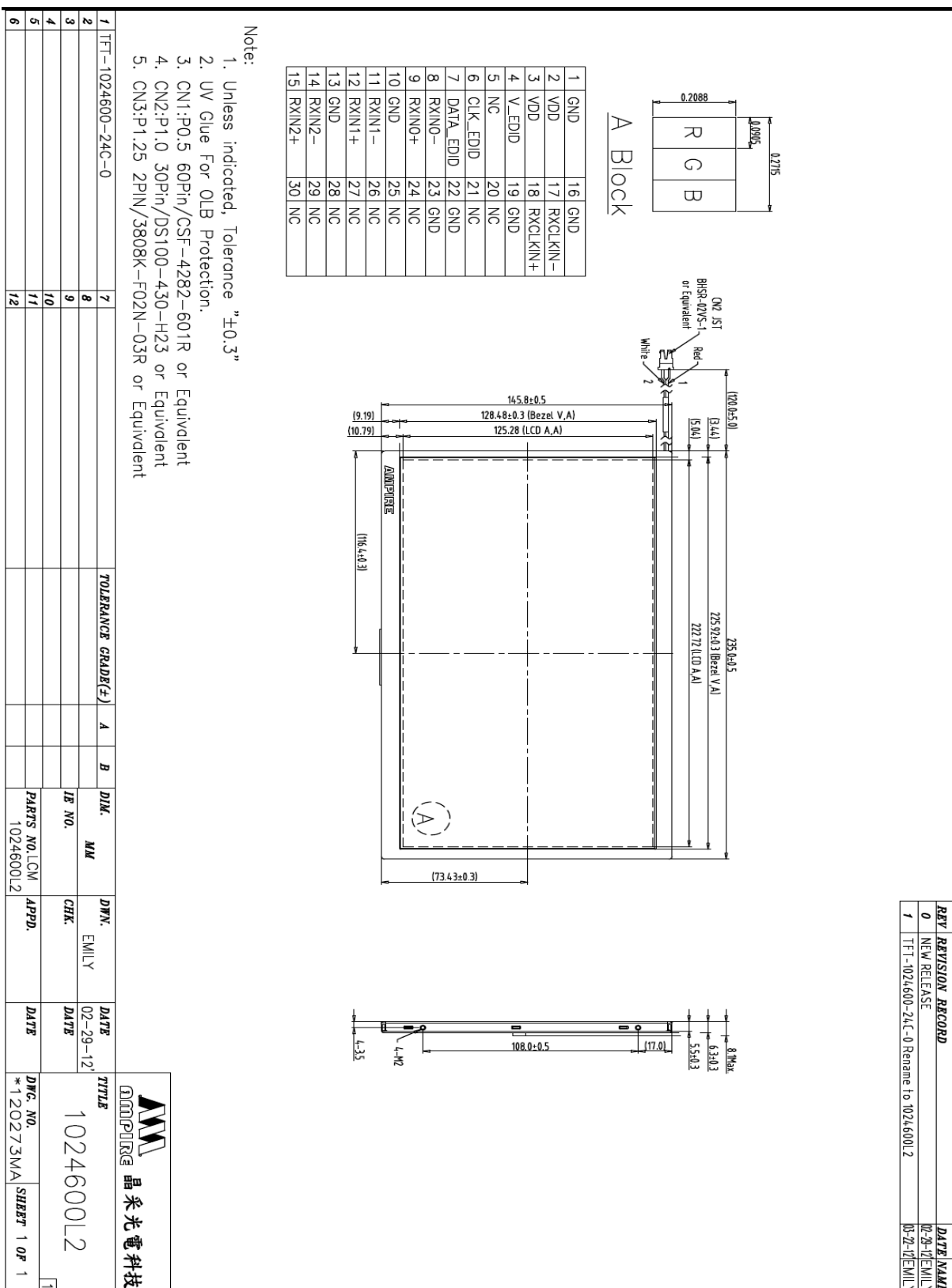

REV	REVISION RECORD	DATE	NAME
0	NEW RELEASE	02-29-12	EMILY
1	TFT-1024600-24C-0 Rename to 1024600L2	03-27-12	EMILY

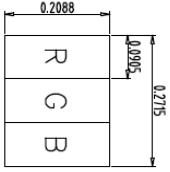

A Block

1	GND	16	GND
2	VDD	17	RXCLKIN-
3	VDD	18	RXCLKIN+
4	V_EDID	19	GND
5	NC	20	NC
6	CLK_EDID	21	NC
7	DATA_EDID	22	GND
8	RXIN0-	23	GND
9	RXIN0+	24	NC
10	GND	25	NC
11	RXIN1-	26	NC
12	RXIN1+	27	NC
13	GND	28	NC
14	RXIN2-	29	NC
15	RXIN2+	30	NC

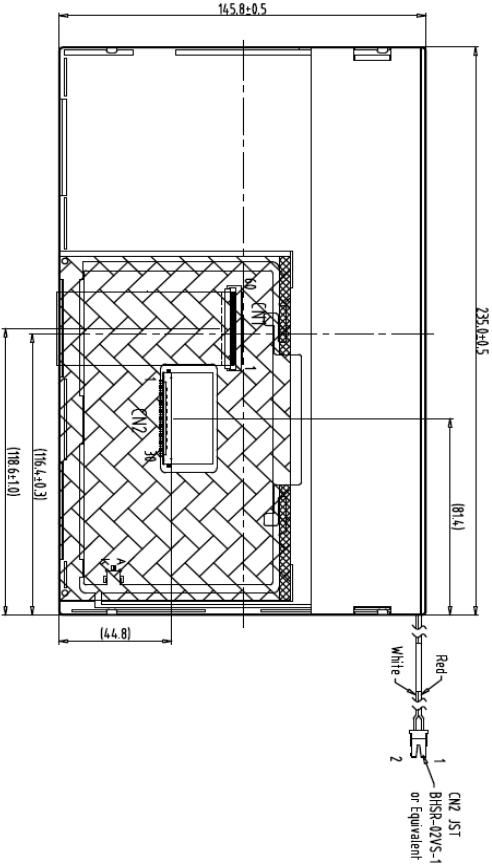

Back view

Note:

1. Unless indicated, Tolerance "±0.3"
2. UV Glue For OLB Protection.
3. CN1:P0.5 60Pin/CSF-4282-601R or Equivalent
4. CN2:P1.0 30Pin/DS100-430-H23 or Equivalent
5. CN3:P1.25 2PIN/3808K-F02N-03R or Equivalent

1	TFT-1024600-24C-0	7		TOLERANCE GRADE(±)	A	B	DIM.	MM	DWN.	EMILY	DATE	02-29-12	TITLE	1024600L2	DWG. NO.	*120274MA	SHEET	1 OF 1
2		8					IE NO.		CHK.		DATE							
3		9					PARTS NO.	LCM-1	APPD.		DATE							
4		10																
5		11																
6		12																

