



AUTO RANGE MULTIMETER

*CAT III – 1000 V category, Auto range, Peak hold
Bar graph display, Max/Min, REL, Cap., Hz, RS232,*

AM-1060 User's Manual



www.tmatlantic.com

Caution Symbol



Caution :

- * Risk of electric shock !



Caution :

- * Do not apply the overload voltage, current to the input terminal !
- * Remove test leads before open the battery cover !
- * Cleaning – Only use the dry cloth to clean the plastic case !

Environment Conditions

- * *Installation Categories III–1000V.*
- * *Pollution Degree 2.*
- * *Altitude up to 2000 meters.*
- * *Indoor use.*
- * *Relative humidity 80% max.*

TABLE OF CONTENTS

1. FEATURES.....	1
2. SPECIFICATIONS.....	2
2-1 General Specifications.....	2
2-2 Electrical Specifications.....	3
3. FRONT PANEL DESCRIPTION.....	6
4. PRECAUTIONS & PREPARATIONS FOR MEASUREMENT.....	7
5. MEASURING PROCEDURE.....	8
5-1 Symbols & Units of Display	8
5-2 DC voltage, AC voltage Measurement	9
5-3 Resistance Measurement.....	9
5-4 DC current, AC current Measurement	10
5-5 Continuity Check	11
5-6 Diode Test	11
5-7 Capacitance Measurement.....	13
5-8 Frequency Measurement.....	13
5-9 Temperature Measurement.....	14
5-10 Relative Measurement.....	14
5-11 Data Hold Operation.....	15
5-12 Peak Hold Measurement.....	15
5-13 Max/Min. value record.....	17
5-14 RS232 Computer Interface.....	17
6. MAINTENANCE.....	18
6-1 Replacement of Battery.....	18
6-2 Cleaning.....	18
6-3 Replacement of Fuse.....	19
7. OPTIONAL ACCESSORIES & ADAPTERS	20
8. THE ADDRESS OF AFTER SERVICE CENTER.....	21

1. FEATURES

- * Meet IEC 1010 CAT III 1000 V safety requirement.
- * Large LCD display with bar graph indicator.
- * Multi function measurement. DCV, ACV, DCA, ACA, Resistance, Capacitance, Frequency, Temperature, Diode, Continuity beeper.
- * Peak hold function (Peak max. hold and Peak min. hold) to measure the level of short wide pulse of ACV, ACA, the useful tool to measure the level value of transient ACV, ACA signal.
- * Max. & Min. measurement value with recall.
- * Relative, Data hold.
- * Auto range with manual range selection.
- * Temperature measurement possibility.
- * VAHz button, when execute the ACV, ACA function also can measure the frequency of signal.
- * 4000 counts A/D, high resolution.
- * Both 10 A, mA, uA current are build fuse for safety consideration.
- * 10 M ohm impedance for voltage circuit.
- * Operates from 2 PCs UM4 1.5 V batteries.
- * Built-in overload protection for most ranges.
- * Photo couple RS 232 computer serial interface.
- * Uses durable, long-lasting components, enclosed in strong, light weight ABS-plastic housing.
- * Full line optional adapters : Clamp adapter, Tachometer adapter, Pressure adapter, Humidity Adapter, Sound level adapter, Anemometer adapter, Light adapter, EMF adapter.

2. SPECIFICATIONS

2-1 General Specifications

Display	65 mm x 48 mm large LCD display with bar graph indicator.
Measurement	DCV, ACV, DCA, ACA, Resistance, Capacitance, Frequency, Temperature, Diode, Continuity beeper.
A/D counts no.	4000 counts.
Range selection	Auto range with manual range selecting.
Special function	Relative measurement, Data hold, Peak hold max. value, Peak hold min., Data hold.
Data hold	To freeze the display reading on the LCD display.
Power On/Off management	Auto power of or manual power off. <i>@ Details please refer page 7</i>
Memory recall	Records Maximum & Minimum readings with recall.
Peak hold value	To measure the signal peak value.
Relative measurement	To offset the measurement value.
VAHz button	When execute the voltage or current function also can measure the frequency of signal.
Data output	RS 232 PC serial interface, photo couple.
Polarity	Automatic Switching, " - " indicates negative polarity.
Zero adjustment	Automatic.
Sampling time	Approx. 0.5 to 1 second.
Operating Temp. & humidity	0 °C to 50 °C (32 °F to 122 °F), Max. 80% RH.
Power supply	1.5 V battery x 2 PCs UM - 4/AAA/Micro/R03 type
Power consumption	Approx. DC 2.5 mA.

Dimension	185 x 88 x 40 mm (7.3 x 3.5 x 1.6 inch).
Weight	350 g/0.77 LB.
Accessories Included	Red and Black Test Leads (CAT III 1KV Test Leads)..... 1 Set 0.5 Amp Spare Fuse..... 1 PC Instruction Manual..... 1 PC
Optional accessories	Full line adapters : ACA/DCA current adapter, Tachometer adapter, Humidity adapter, Pressure adapter, Light adapter, EMF adapter, Sound level adapter, High voltage probe. Type K Temperature probeTP-11 RS232 cable.....UPCB-06

2-2 Electrical Specifications (23 ± 5 °C)

DC Voltage	
Range	400.0 mV /4 V/40 V/400 V Δ /1000 V Δ
Resolution	0.1 mV /1 mV /10 mV /100m V/1 V
Accuracy	$\pm(0.5\% + 2d) - 400\text{ mV.}$ $\pm(0.8\% + 1d) - 4\text{ V, } 40\text{ V, } 400\text{ V, } 1000\text{ V.}$
Input impedance	10 M ohm.
Over load protection	$\pm 500\text{ DCV, } 350\text{ ACV} - 200\text{ mV range.}$ $\pm 1000\text{ DCV, } 1000\text{ ACV} - \text{other ranges.}$

AC Voltage	
Range	400.0 mV /4 V/40 V/400 V Δ /1000 V Δ
Resolution	0.1 mV /1 mV /10 mV /100m V/1 V
Accuracy	$\pm(1\% + 2d)$ * Spec. are tested under 50/60 Hz.
Input impedance	10 M ohm.
Over load protection	$\pm 500\text{ DCV, } 350\text{ ACV} - 200\text{ mV range.}$ $\pm 1000\text{ DCV, } 1000\text{ ACV} - \text{other ranges.}$

DC Current, AC Current	
Range	10 A/400 mA/40 mA/4000 uA/400 uA
Resolution	10 mA/0.1 mA/0.01 mA/1 uA/0.1 uA
Accuracy	400 uA : $\pm (1 \% + 2d)$ 4000 uA : $\pm (1.5 \% + 2d)$ 40 mA : $\pm (1 \% + 2d)$ 400 mA : $\pm (1.5 \% + 2d)$ 10 A : $\pm (1.5 \% + 2d)$ <i>* ACA spec. are tested under 50/60 Hz.</i>
Over load protection	10A range : 10A fuse. uA, mA range : 500 mA fuse.

Diode (Forward voltage, VF)	
Range	4 V DC.
Accuracy	$\pm (0.5\% + 2d)$

Capacitance	
Range	4 nF/40 nF/400 nF/4 uF/40 uF/400 uF 4 mF/40 mF
Resolution	1 pF/10 pF/0.1 nF/1 nF/10 nF/0.1 uF 1 uF/10 uF
Accuracy	$\pm (3 \% + 1d)$

Frequency	
Range	4 KHz/40 KHz/400 KHz/4 MHz/40 MHz
Resolution	1 Hz/10 Hz/0.1 KHz/1 kHz/0.01 MHz/0.1 MHz
Accuracy	$\pm (0.5\% + 2d)$
Sensitivity	Min. 1 V rms, Max. 5 V rms.

OHMS	
Range	400/4 K/40 K/400 K/4 M/40 M ohm
Resolution	0.1/1/10/100/1 K/10 K ohm
Accuracy	400 ohm : $\pm (1 \% + 2d)$ 4K/40K/400K/4 M : $\pm (1.5 \% + 2d)$ 40 M : $\pm (3 \% + 5d)$
Over load protection	± 500 DCV, 350 ACV.

Continuity Beeper	
Beeper will sound if measured resistance less than 20 ohm.	

Peak Hold (Peak max. hold, Peak min. hold)	
Application	To measure the short wide pulse of ACV, ACA, useful tool to measure the level value of transient (surge) ACV, ACA signal.
Mode	Peak max. hold and Peak min. hold mode.
Acquisition Time	> 1 mS (milli-second).

Max. & Min. Measurement	
During the operation can memorize the maximum and the minimum measurement value.	

Temperature	
Range	-20 °C to 750 °C
Resolution	1 °C
Accuracy	-20 °C to 300 °C : $\pm (1 \% + 2 °C)$ 301 °C to 750 °C : $\pm 3\%$ reading
Temp. probe	The temperature probe (TP-11) is the optional accessory.

Remark :

* *Spec. tested under the environment RF Field Strength less than 3 V/M & frequency less than the 30 MHz only.*

3. FRONT PANEL DESCRIPTION

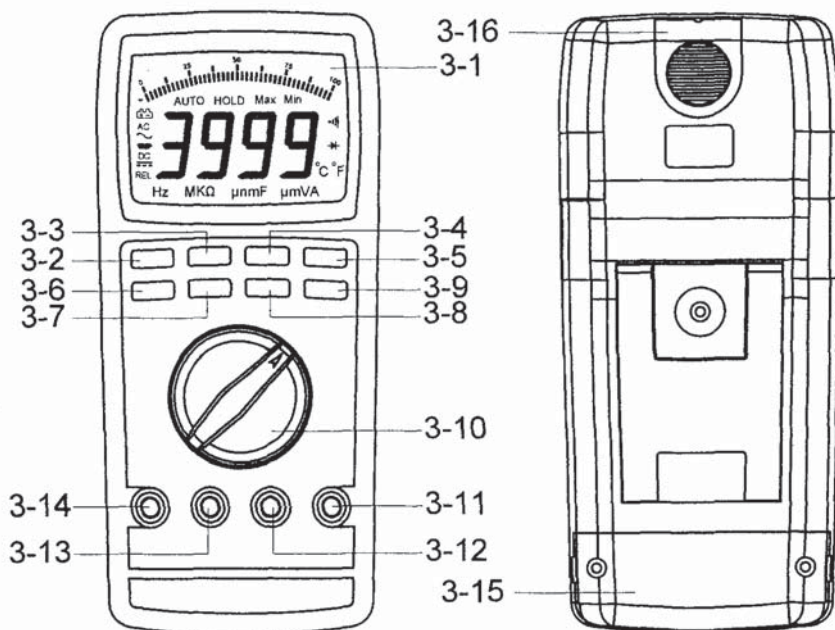

Fig. 1





- | | |
|--------------------|---|
| 3-1 Display | 3-10 Function rotary switch |
| 3-2 MAX/MIN button | 3-11 Temp./ohm/V/Cap.
input terminal |
| 3-3 PEAK button | 3-12 COM input terminal |
| 3-4 REL button | 3-13 mA/uA input terminal |
| 3-5 HOLD button | 3-14 10A input terminal |
| 3-6 RANGE button | 3-15 Battery compartment/Cover |
| 3-7 VAHz button | 3-16 RS232 terminal |
| 3-8 RS232 button | |
| 3-9 AC/DC button | |

4. PRECAUTIONS & PREPARATIONS FOR MEASUREMENT

- 1) Ensure that the DC 1.5V x 2 batteries are connected with the right polarity and placed in the battery compartment correctly.
- 2) Place the Red & Black Test Leads into the proper input terminal before making measurement.
- 3) Remove either of the test leads from the circuit when changing the measurement range.
- 4) Except operate the " Data Hold " function, it should cancel the " Data Hold " function, otherwise the display reading will freeze permanently.
- 5) Do not exceed the maximum rated voltage and current to the input terminal.
- 6) Always switching the " Function Rotary Switch " to the " Off " position when the instrument is not operation.
- 7) Remove the battery if the instrument is not to be used in a long period of time.
- 8) For safety consideration, when change the new test leads, it should use the replace test leads that already approval of " CATIII – 1000 V " at least.
- 9) Power On/Off management :
 - a. When not use the meter, should rotate the " Function rotary switch " (3–10, Fig. 1) to the " OFF " position.
 - b. During the measurement, after 30 minutes the meter will auto power off. If intend to power on again, it should rotate the " Function switch " to " OFF " position then set to the new desiring function position.
 - c. ***Disabling auto power off (not auto power off)***
Press the " MAX/MIN button " (3–2, Fig. 1) while turning the " Function switch " from the " OFF " position to the desiring function position.

5. MEASURING PROCEDURE

5-1 Symbols & units of display

Symbols Units	Descriptions
AUTO	Appears when selecting " Automatic range " mode.
MANU	Appears when selecting " Manual range " mode.
DC 	Appears when selecting DC mode. (DC voltage or DC current)
AC 	Appears when selecting AC mode. (AC voltage or AC current)
HOLD	Appears when the " Data hold " function is operated.
REL	Appears when the " Relative " function is operated.
PMax PMin	Appears when the " Peak Max. " or " Peak Min. " function is operated.
Max Min	Appears when " Max and Min. value record " function is operated.
	Battery voltage is already under the low condition.
	Appears when the " Continuity beeper " is operated.
mV, V	Units for voltage measurements.
uA,mA,A	Units for " Current " measurement.
Ω ,K Ω ,M Ω	Units for resistance measurements.
nF,uF,mF	Units for " Capacitance " measurement.
KHz,MHz	Units for " Frequency " measurement.
	Appears when the " Diode " function is operated.
-	Appears when measuring a DCV or DCA value is negative.
°C	Units for " Temperature " measurement.
OL	Over range indicator
RS232	RS232 data is already send output from the meter.

5-2 DC Voltage, AC voltage Measurement

- 1) Connect BLACK test lead into " COM " terminal (3-12, Fig. 1).
- 2) Connect RED test lead into " V " terminal (3-11, Fig. 1).
- 3) Select the " Function rotary switch " (3-10, Fig. 1) to the " V " position.
- 4) Push the " AC/DC button " (3-9, Fig. 1) to select the " ACV " or " DCV " measurement,
- 5) When LCD show the " AUTO " marker, the meter is under the " auto range " mode. Meter will select the suitable measurement range automatically.
- 6) Under the operation of " auto range " mode, push the " Range button " (3-6 Fig. 1) once will execute the " Manual Range " mode and hold the range, the LCD will show the " MANU " marker.
Under the manual range operation, push the " Range button " (3-6 Fig. 1) > 2 seconds, will return to auto range operation.

Remark :

During the measurement, if push the " VAHz button " (3-7 Fig. 1) once, until the LCD show the " Hz " marker and the display will show the frequency value of the measurement signal.

5-3 Resistance Measurement

- 1) Connect BLACK test lead into " COM " terminal (3-12, Fig. 1).
- 2) Connect RED test lead into " Ω " terminal (3-11, Fig. 1).
- 3) Select the " Function rotary switch " (3-10, Fig. 1) to the " Ω " position.
- 4) When LCD show the " AUTO " marker, the meter is under the " auto range " mode. Meter will select the suitable measurement range automatically.

- 5) Under the operation of " auto range " mode, push the " Range button " (3-6 Fig. 1) will execute the " Manual Range " mode and hold the range, the LCD will show the " MANU " marker.
Under the manual range operation, push the " Range button " (3-6 Fig. 1) > 2 seconds, will return to auto range operation.

5-4 DC Current, AC Current Measurement

mA : 400 mA range, 40 mA range.

uA : 4000 uA range, 400 uA range.

- 1) Connect BLACK test lead into " COM " terminal (3-12, Fig. 1).
- 2) For the " mA, uA " measurement, connect RED test lead into " mA uA " terminal (3-13, Fig. 1).
For the " 10 A " current measurement, connect RED test lead into " A " terminal (3-14, Fig. 1).

Open the circuit in which current is to be measured. Now securely connect test leads in series with the load in which the current is be measured.

- 3) For the " uA " measurement (400 uA, 4000 uA), select the " Function rotary switch " (3-10, Fig. 1) to " uA " position.
For the " mA " measurement (40 mA, 400 mA), select the " Function rotary switch " (3-10, Fig. 1) to " mA " position.
For the " 10 A " measurement, select the " Function rotary switch " (3-10, Fig. 1) to " A " position.
- 4) Push the " AC/DC button " (3-9, Fig. 1) to select the " ACA " or " DCA " measurement,
- 5) When LCD show the " AUTO " marker, the meter is under the " auto range " mode. Meter will select the suitable measurement range automatically.

- 6) Under the operation of " auto range " mode, push the " Range button " (3-6 Fig. 1) once will execute the " Manual Range " mode and hold the range, the LCD will show the " MANU " marker.

Under the manual range operation, push the " Range button " (3-6 Fig. 1) > 2 seconds, will return to auto range operation.

Remark :

During the measurement, if push the " VAHz button " (3-7 Fig. 1) once, until the LCD show the " Hz " marker and the display will show the frequency value of the measurement signal.

5-5 Continuity Check

- 1) Connect BLACK test lead into " COM " terminal.
- 2) Connect RED test lead into " Ω " terminal.
- 3) Select the " Function rotary switch " (3-10, Fig. 1) to the " $\cdot\|$ " position.
- 4) The LCD display will show the " $\cdot\|$ " marker.
- 5) when the resistance value is less than 20 ohm, the beeper sound will be generated.

5-6 Diode Test

- 1) Connect BLACK test lead into " COM " terminal.
- 2) Connect RED test lead into " V " terminal.
- 3) Select the " Function rotary switch " (3-10, Fig. 1) to the " $\rightarrow\|$ " position.
The LCD display will show the " $\rightarrow\|$ " marker.
- 4) a. When connected with polarity as shown in Fig. 2, a forward current flow is established and the approx. Diode Forward Voltage (VF) value in volt will appears on the display reading. If the diode under test is defective, " 0.000 " or near " 0.000 " value (short circuit) " OL " (open circuit) will be displayed.

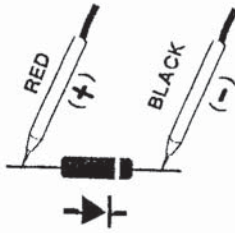

Fig. 2

- b. When connected as shown in Fig. 3, a reverse check on the diode is made. If the diode under test is good, " OL " will be displayed. If the diode under test is defective, " 0.000 " or other numbers will be displayed. Proper diode testing should include both steps a. and b. above.

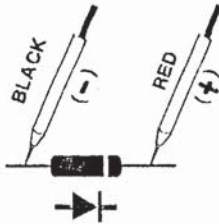

Fig. 3

5-7 Capacitance Measurement

- 1) Select the " Function rotary switch " (3-10, Fig. 1) to the " \pm " position.
- 2) Connect the tested capacitor to " Input terminals " directly.

- * If the measured capacity existing the polarity, then should connect the " + " polarity of the measured capacitor to the " V " terminal (3-11, Fig. 1), connect the " - " polarity of the measured capacitor to the " COM " terminal (3-12, Fig. 1),*
- * Full discharge the measured capacitor before the make the measurement.*

- 3) When LCD show the " AUTO " marker, the meter is under the " auto range " mode. Meter will select the suitable measurement range automatically.
- 4) Under the operation of " auto range " mode, push the " Range button " (3-6 Fig. 1) once will execute the " Manual Range " mode and hold the range, the LCD will show the " MANU " marker.
Under the manual range operation, push the " Range button " (3-6 Fig. 1) > 2 seconds, will return to auto range operation.

5-8 Frequency Measurement

- 1) Connect BLACK test lead into " COM " terminal (3-12, Fig. 1).
- 2) Connect RED test lead into " V " terminal (3-11, Fig. 1).
- 3) Select the " Function rotary switch " (3-10, Fig. 1) to the " Hz " position.
LCD will show the " K Hz (M Hz) " marker.

- 4) When LCD show the " AUTO " marker, the meter is under the " auto range " mode. Meter will select the suitable measurement range automatically.
- 5) Under the operation of " auto range " mode, push the " Range button " (3-6 Fig. 1) once will execute the " Manual Range " mode and hold the range, the LCD will show the " MANU " marker.
Under the manual range operation, push the " Range button " (3-6 Fig. 1) > 2 seconds, will return to auto range operation.
- 6) *Under the ACV measurement (5-2) or ACA measurement (5-4), if push the " VAHz button " (3-7, Fig. 1) once a while until the display show the " K Hz " marker, at the same time will also show frequency value of the measured ACV or ACA.*

5-9 Temperature Measurement

- 1) Plug in the optional " Type K Temperature probe, TP-11 " into the input terminals, " V input terminal " (3-11, Fig. 1) and the " COM input terminal " (3-12, Fig. 1)
- 2) Select the " Function rotary switch " (3-10, Fig. 1) to the " Temp. " position.

Under the temperature operation, if not plug in the temperature probe, the beeper will sound for warning.

5-10 Relative Measurement

- 1) During the measurement of ACV, ACA, DCV, DCA, ohm, Capacitance, Frequency and Temperature, the circuit will memorize the last measured values if push the " REL. button " (3-4, Fig. 1) at once, then LCD will show zero value & a " REL " indicator.

- 2) The input measured values will deduct last measured values " automatically, then show those new value on the display.
- 3) It will cancel the Relative Measurement function if push the REL. button at once again, at same time the " REL ." marker will disappear.

5-11 Data Hold Operation

- 1) During the measurement, pushing the " Hold button " (3-5, Fig. 1) once a while will freeze the measured value & the LCD will indicate " HOLD " symbol.
- 2) Push the " Hold Button " again to cancel the data hold function.

5-12 Peak Hold Measurement

The peak hold measurement are used under the ACV, DCV, ACA, DCA function.

Acquisition time of Peak Hold function should > 1 mS (milli-second).

- 1) Application : To measure the short wide pulse of ACV, ACA, the useful tool to measure the level value of transient (surge) ACV, ACA signal.
- 2) Two Modes : Peak max. hold and Peak min. hold mode.
- 3) Setup the measured circuit ready amd completely, switch off the power supply of the measured installation.
- 4) Used the " RANGE button " 3-6, Fig. 1 " to select the desired manual range.

* For the 10 A (AC/DC) range, it is only one range, do not necessary to use the " Range button " to select the range.

- 5) Push the " PEAK button " (3-3, Fig. 1) > 3 second, the display will show " CAL " marker, then show zero value, it will execute the offset (zero) procedure.
- 6) Push the " PEAK button " (3-3, Fig. 1) once while again, the display will show " PMax " marker.
Now the meter is ready for the " Peak Max Hold " operation.
Push the " PEAK button " (3-3, Fig. 1) once while again, the display will show " PMin " marker.
Now the meter is ready for the " Peak Min Hold " operation.

* PMax mode is intend to measure the " Positive " peak hold level.

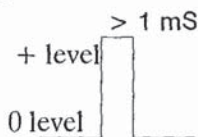

* PMin mode is intend to measure the " Minus " peak hold level.

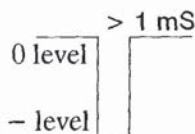

- 7) Power on the measured installation, the display will show the " PMax " value (if select the PMax mode) or " PMin " value (if select the PMin mode).
- 8) Under operate the " Peak Hold " function (display show the marker of " PMax " or " PMin "), if intend to cancel the Peak Hold function just push the " PEAK button " (3-3, Fig. 1) > 2 seconds continuously.

5-13 Max and Min. value record

- 1) Application : To record the maximum and the minimum reading value during the measurement.
- 2) Used the " RANGE button " 3-6, Fig. 1 " to select the desired manual range.
** For the 10 A (AC/DC) range, it is only one range, do not necessary to use the " Range button " to select the range.*
- 3) Push the " MAX/MIN button " (3-2, Fig. 1) once 3 times, the display will show the " Min Max " two markers together with flash, now the meter is ready for recording the " Max. " and " Min. " value.
- 4) Push the " MAX/MIN button " (3-2, Fig. 1) once again the display will show the " Max " maker along with the maximum measured value.
Push the " MAX/MIN button " (3-2, Fig. 1) once again the display will show the " Min " maker along with the minimum measured value.
- 5) If intend to cancel the " Max/Min Record function" just push the " MAX/MIN button " (3-2, Fig. 1) > 2 seconds continuously.

5-14 RS232 Computer Interface

- 1) Connect the optional RS232 cable (UPCB-06) to the RS232 terminal (3-16, Fig. 1)
- 2) Push the " RS232 button " (3-8, Fig. 1), display will show " RS232 " marker, at the same time the serial data bus will send from the meter via the " RS232 terminal " to the computer.
- 3) Push the " RS232 button " (3-17, Fig. 1) again, will stop to send the data output from the meter, at the same time the " RS232 " marker will be disappeared.

6. MAINTENANCE

6-1 Battery replacement



Caution : *Remove test leads before opening the battery cover !*

- 1) When the LCD display showing the mark of "  ", it is necessary to replace the battery, However in-spec. measurement may still be made for several hours after " Low battery indicator " appears before the instrument become inaccurate.
- 2) Open the screw of " Battery Cover " (3-15, Fig. 1) by loosing the screws, then move the battery.
- 3) Replace with 1.5 V x 2 batteries (AAA, UM4 type) and reinstate the cover.

6-2 Cleaning



Caution : *Cleaning – Only use the dry cloth to clean the plastic case !*

6-2 Replacement of Fuse



Caution :

a. Fuse A –

Rating : 500 mA, Size : 5 mm dia. x 20 mm

To be protected the circuit from overload current at " 400 uA, 4000 uA, 40 mA, 400 mA " range. (in other overload protection circuit).

b. Fuse B –

Rating : 10 A, Size : 6 mm dia. x 30 mm

To be protected the circuit from overload current at " 10 A " range.

- 2) When the uA, mA current range can not operation, please check if the Fuse A is broken or not:
When the 10 A current range can not operation, please check if the Fuse B is broken or not:
- 3) When replace the fuse should take the test leads from the measuring circuit and power off the meter.
- 4) Take the screws away from the down case, loose the housing case, the fuses are install on the fuse socket on the PCB.
- 5) For safety consideration, when replace the fuse according the spec. (should use the approval fuse) and reinstall the cover.
- 6) Make sure the housing case is secured with the screw after replace the fuse.

7. OPTIONAL ACCESSORIES & ADAPTERS

<i>Item</i>	<i>Model</i>
<i>Carrying Case</i>	<i>CA-05A</i>
<i>Humidity Adapter</i>	<i>HA-702</i>
<i>Light Adapter</i>	<i>LX-02</i>
<i>EMF Adapter</i>	<i>EMF-824</i>
<i>Pressure Adapter</i>	<i>PS-403</i>
<i>Anemometer Adapter</i>	<i>AM-402</i>
<i>Tachometer Adapter</i>	<i>TA-601</i>
<i>Sound Adapter</i>	<i>SL-406</i>
<i>High Voltage Probe</i>	<i>HV-40</i>