

Cascadable Amplifier 10 to 500MHz

Rev. V5

Features

- NOISE FIGURE: 5 dB (TYP.)
- HIGH THIRD ORDER IP: +38 dBm (TYP.)
- P1dB: +21 dBm (TYP.)

Description

The AM-151 amplifier uses a coupler feedback design with high intercept and compression points. The use of coupler feedback minimized noise figure and DC current in a high intercept amplifier. This amplifier is packaged a TO-8 package. Due to the internal power dissipation, the thermal rise is minimized. The ground plane on the PC board should be configured to remove heat from under the package. AM-151 is ideally suited for use where a high intercept high reliability amplifier is required.

Product Image

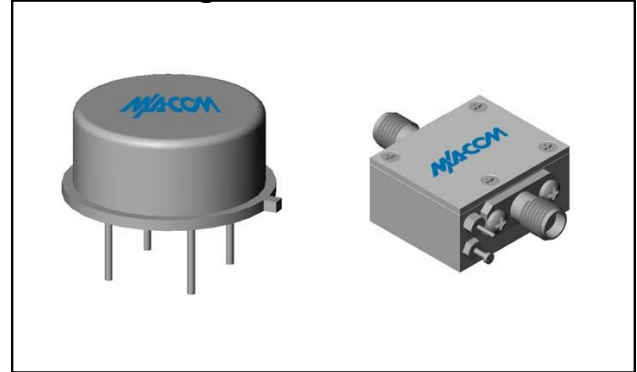

Ordering Information

Part Number	Package
AM-151-PIN*	TO-8-1
AMC-151- SMA**	SMA Connectorized

*Mounting kit part number AU00071 required for PCB application

**SMA Connectorized part is not RoHs compliant.

Absolute Maximum Ratings

Parameter	Absolute Maximum
Maximum Input Power	+20 dBm
DC Voltage	+15.75 V
Continuous Input Power	+18 dBm
Operating Temperature	-55° to +85°C
Storage Temperature	-65° to +125°C

Electrical Specifications: $Z_0 = 50\Omega$, $V_{CC} = +15 V_{DC}$ **

Parameter	Test Conditions	Frequency	Units	Min.	Typ.	Max.
Gain	@ +25°C	50 MHz	dB	11.5	12.0	12.5
Frequency Response	—	5-500 MHz	dB	—	—	±1.0
Gain Variation with Temperature	—	5-500 MHz	dB	—	—	±0.8
1 dB Compression	Output Power	5-500 MHz 10-500 MHz	dBm dBm	+19 +20	— —	— —
Noise Figure (max)	—	5-500 MHz	dB	—	—	7.0
Reverse Transmission	—	5-500 MHz	dB	—	-16.0	-13.0
VSWR	—	5-500 MHz	Ratio	—	—	2.0:1
Output IP ²	Two-tone inputs up to +10 dBm	5-500 MHz	dBm	+48	—	—
Output IP ³	Two-tone inputs up to +10 dBm	5-500 MHz	dBm	+34	—	—
V bias	—	—	dBm	+14.5	+15.0	+15.5
I bias	V bias = +15 Vdc	—	mA	—	85	100
Power Dissipation	@ +15 V Bias	—	mW	—	1275	—

***Heat Sinking: Operation at case temperature above +95°C is not recommended. Heat sinking adequate to dissipate 1.3 W must be provided in use.

Typical Performance Curves at +25°C

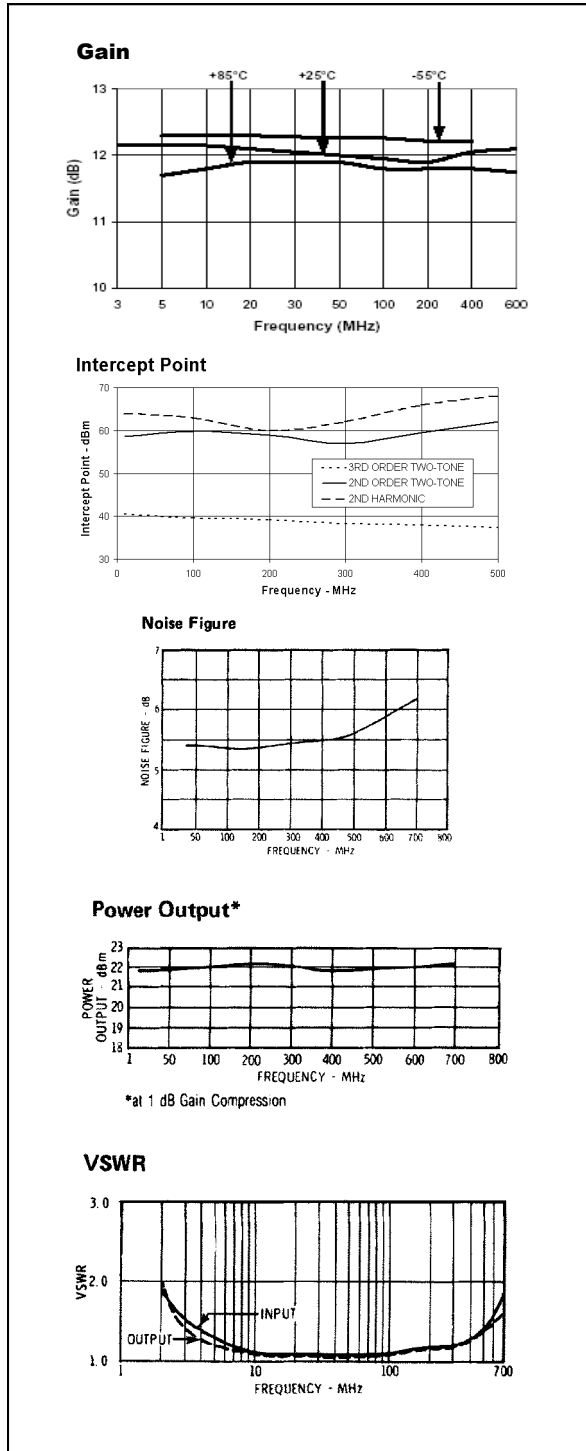

Outline Drawing: TO-8-1 *

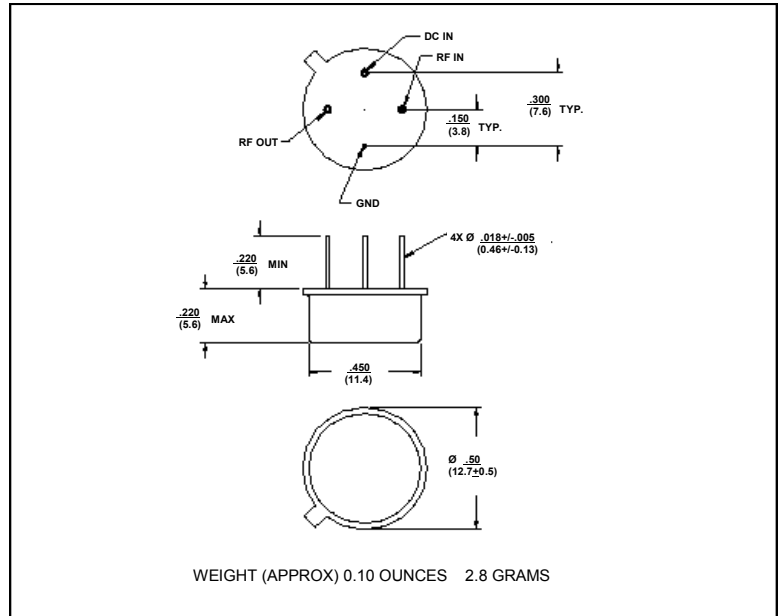

Outline Drawing: SMA Connectorized *

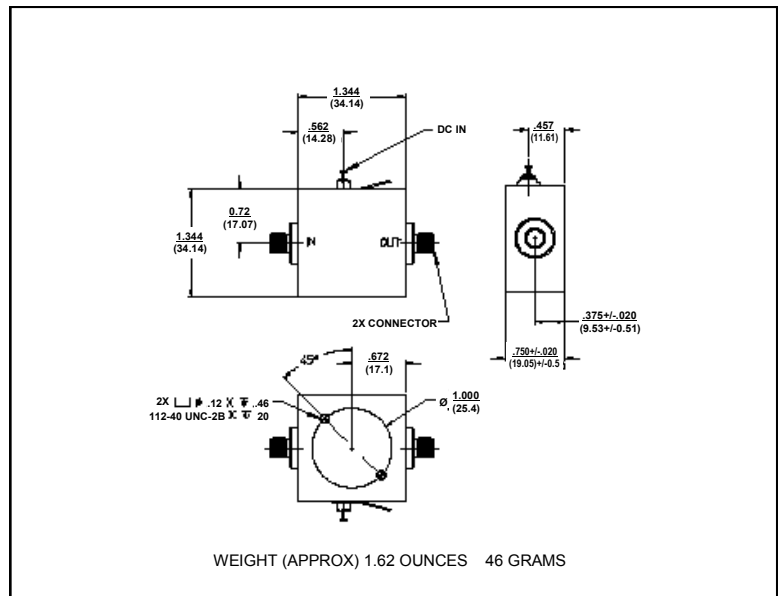

* Dimensions in () are in mm.
Unless otherwise noted: .XXX = + .010" (.XX = + 0.25)
.XX = + 0.02 (.X = ± 0.5)

M/A-COM Technology Solutions Inc. All rights reserved.

Information in this document is provided in connection with M/A-COM Technology Solutions Inc ("MACOM") products. These materials are provided by MACOM as a service to its customers and may be used for informational purposes only. Except as provided in MACOM's Terms and Conditions of Sale for such products or in any separate agreement related to this document, MACOM assumes no liability whatsoever. MACOM assumes no responsibility for errors or omissions in these materials. MACOM may make changes to specifications and product descriptions at any time, without notice. MACOM makes no commitment to update the information and shall have no responsibility whatsoever for conflicts or incompatibilities arising from future changes to its specifications and product descriptions. No license, express or implied, by estoppel or otherwise, to any intellectual property rights is granted by this document.

THESE MATERIALS ARE PROVIDED "AS IS" WITHOUT WARRANTY OF ANY KIND, EITHER EXPRESS OR IMPLIED, RELATING TO SALE AND/OR USE OF MACOM PRODUCTS INCLUDING LIABILITY OR WARRANTIES RELATING TO FITNESS FOR A PARTICULAR PURPOSE, CONSEQUENTIAL OR INCIDENTAL DAMAGES, MERCHANTABILITY, OR INFRINGEMENT OF ANY PATENT, COPYRIGHT OR OTHER INTELLECTUAL PROPERTY RIGHT. MACOM FURTHER DOES NOT WARRANT THE ACCURACY OR COMPLETENESS OF THE INFORMATION, TEXT, GRAPHICS OR OTHER ITEMS CONTAINED WITHIN THESE MATERIALS. MACOM SHALL NOT BE LIABLE FOR ANY SPECIAL, INDIRECT, INCIDENTAL, OR CONSEQUENTIAL DAMAGES, INCLUDING WITHOUT LIMITATION, LOST REVENUES OR LOST PROFITS, WHICH MAY RESULT FROM THE USE OF THESE MATERIALS.

MACOM products are not intended for use in medical, lifesaving or life sustaining applications. MACOM customers using or selling MACOM products for use in such applications do so at their own risk and agree to fully indemnify MACOM for any damages resulting from such improper use or sale.