

Specification for Approval

Customer: _____

Model Name: _____

| Supplier Approval | | | Customer approval |
|-------------------|--------------|-------------|-------------------|
| R&D Designed | R&D Approved | QC Approved | |
| <i>Peter</i> | Peng Jun | | |

Revision Record

| REV NO. | REV DATE | CONTENTS | Note |
|---------|------------|-----------|------|
| A | 2015-10-14 | NEW ISSUE | |
| | | | |
| | | | |
| | | | |
| | | | |
| | | | |
| | | | |
| | | | |
| | | | |
| | | | |
| | | | |
| | | | |
| | | | |
| | | | |
| | | | |
| | | | |
| | | | |
| | | | |
| | | | |
| | | | |
| | | | |
| | | | |

Table of Contents

| List | Description | Page No. |
|------|---|----------|
| | Cover | 1 |
| | Revision Record | 2 |
| | Table of Contents | 3 |
| 1 | Scope | 4 |
| 2 | General Information | 4 |
| 3 | External Dimensions | 5 |
| 4 | Interface Description | 6 |
| 5 | Absolute Maximum Ratings | 7 |
| 6 | Electrical Characteristics | 7 |
| 7 | Timing Characteristics | 8 |
| 8 | Backlight Characteristics | 9 |
| 9 | Optical Characteristics | 10 |
| 10 | Reliability Test Conditions and Methods | 12 |
| 11 | Inspection Standard | 13 |
| 12 | Handling Precautions | 17 |
| 13 | Precaution for Use | 18 |
| 14 | Packing Method | 18 |

1. Scope

This specification defines general provisions as well as inspection standards for TFT module supplied by AMSON electronics.

If the event of unforeseen problem or unspecified items may occur, naturally shall negotiate and agree to solution

2. General Information

| ITEM | STANDARD VALUES | UNITS |
|-----------------------|--------------------------------------|-------|
| LCD type | 2.2" TFT | -- |
| Dot arrangement | 240(RGB) × 320 | dots |
| Color filter array | RGB vertical stripe | -- |
| Display mode | TN / Transmission / Normally White | -- |
| Viewing Direction | 12 O'clock (Gray inversion) | -- |
| Driver IC | ST7789V | -- |
| Module size | 38.38(W) × 59.19(H) × 2.4(T) | mm |
| Active area | 33.48(W) × 44.64(H) | mm |
| Dot pitch | 0.1395(W) × 0.1395(H) | mm |
| Interface | i80-system 8/16-bit MCU interface | -- |
| Operating temperature | -20 ~ +70 | °C |
| Storage temperature | -30 ~ +80 | °C |
| Back Light | 4 White LED | -- |
| Weight | TBD | g |

3. External Dimensions

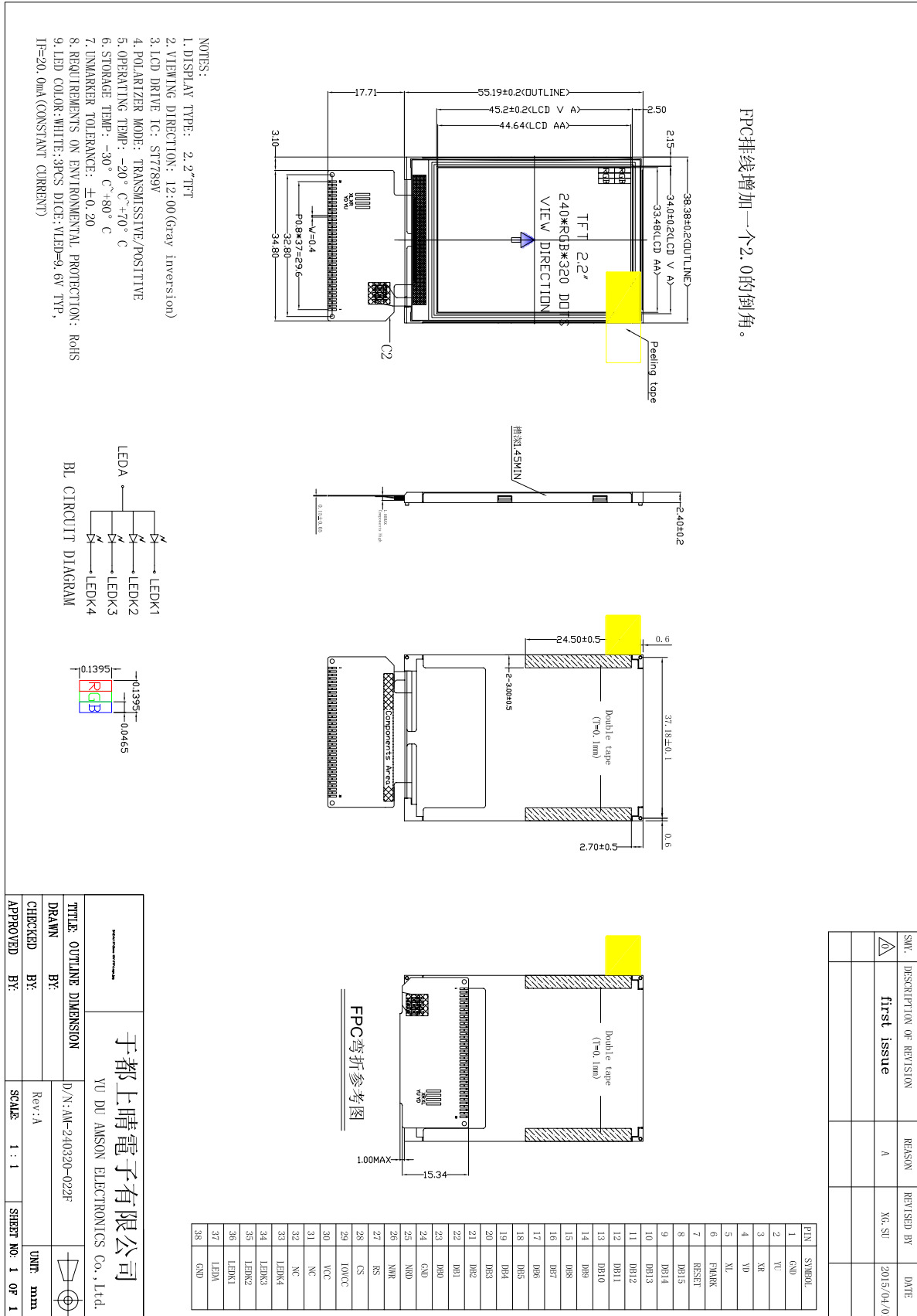

FPC排线增加一个2.0的倒角。

| SM | DESCRIPTION OF REVISION | REASON | REVISED BY | DATE |
|----|-------------------------|--------|------------|------------|
| △ | first issue | A | XG.SUI | 2015/04/01 |

| | | | |
|-----------------------------------|---------------------|-----------------------------------|------------------|
| YU DU AMSON ELECTRONICS Co., Ltd. | | YU DU AMSON ELECTRONICS Co., Ltd. | |
| TITLE: OUTLINE DIMENSION | D/N: AM-240320-022F | Rev: A | UNIT: mm |
| DRAWN BY: | | SCALE: 1:1 | SHEET NO: 1 OF 1 |
| CHECKED BY: | | | |
| APPROVED BY: | | | |

4. Interface Description

| PIN NO. | PIN NAME | DESCRIPTION |
|---------|----------|--|
| 1 | GND | Ground |
| 2 | YU | Y Up |
| 3 | XR | X Right |
| 4 | YD | Y Down |
| 5 | XL | X Left |
| 6 | FMARK | Tearing effect signal is used to synchronize MCU to frame memory. |
| 7 | RESET | Reset pin. Initializes the IC. When this signal is low. Must be reset after power is stable. |
| 8-23 | DB15-DB0 | Data Bus |
| 24 | GND | Ground |
| 25 | NRD | Read enable pin I80 parallel bus system interface |
| 26 | NWR | Write enable pin I80 parallel bus system interface |
| 27 | RS | Register select pin. Low: Index/status, High: Control. |
| 28 | CS | Input pin for chip selection signal |
| 29 | IOVCC | Logic operating voltage |
| 30 | VCC | Analog operating voltage |
| 31 | NC | NC |
| 32 | NC | NC |
| 33 | LEDK4 | LED backlight (Cathode) |
| 34 | LEDK3 | LED backlight (Cathode) |
| 35 | LEDK2 | LED backlight (Cathode) |
| 36 | LEDK1 | LED backlight (Cathode) |
| 37 | LEDA | LED backlight (Anode) |
| 38 | GND | Ground |

5. Absolute Maximum Ratings

| Item | Symbol | Min. | Max. | Unit |
|-----------------------|--------|------|---------|------|
| Logic Supply Voltage | VCC | -0.3 | 4.6 | V |
| Analog Supply Voltage | VCI | -0.3 | 4.6 | V |
| Input Voltage | Vin | -0.3 | VCC+0.3 | V |
| Operating Temperature | TOP | -20 | 70 | °C |
| Storage Temperature | TST | -30 | 80 | °C |
| Storage Humidity | HD | 20 | 90 | %RH |

6. DC Characteristics

| Item | Symbol | Min. | Typ. | Max. | Unit | Remark |
|-----------------------|-----------------|---------|------|---------|------|--------|
| Logic Supply Voltage | VCC | 1.65 | 2.8 | 3.3 | V | - |
| Analog Supply Voltage | VCI | 2.5 | 2.8 | 3.3 | V | - |
| Input High Voltage | V _{IH} | 0.7 VCC | - | VCC | V | - |
| Input Low Voltage | V _{IL} | GND | - | 0.3 VCC | V | - |
| Output High Voltage | V _{OH} | 0.8 VCC | - | VCC | V | - |
| Output Low Voltage | V _{OL} | GND | - | 0.2 VCC | V | - |
| I/O Leak Current | I _{LI} | -1 | - | 1 | uA | - |

NOTE:

Measuring Condition : Standard Value MAX.

Ta = 25°C

VCC-VSS = +2.8V

VCI-VSS = +2.8V

Fosc = 615KHZ

Display Patten=Checked pattern

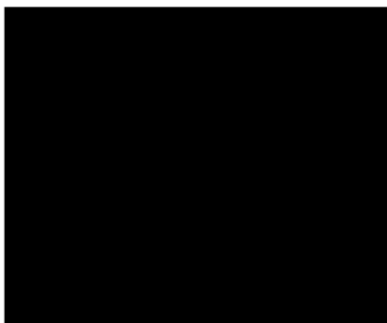

0 gray black pattern

7. Timing Characteristics

7.1 8080 Series MCU Parallel Interface Timing Characteristics:8/16bit BUS

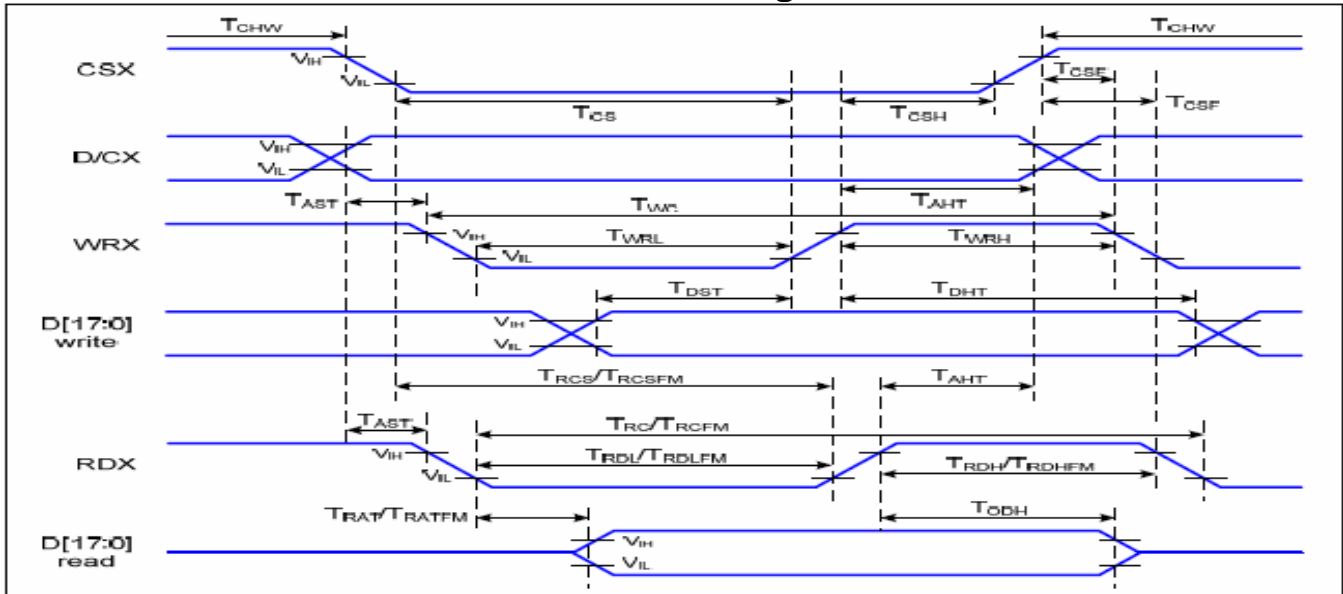

VDDI=1.65 to 3.3V, VDD=2.4 to 3.3V, AGND=DGND=0V, Ta= -30 to 70 °C

| Signal | Symbol | Parameter | Min | Max | Unit | Description |
|----------|--------------------|------------------------------------|-----|-----|------|-----------------------------|
| D/CX | T _{AST} | Address setup time | 0 | | ns | |
| | T _{AHT} | Address hold time (Write/Read) | 10 | | ns | |
| CSX | T _{CHW} | Chip select "H" pulse width | 0 | | ns | |
| | T _{CS} | Chip select setup time (Write) | 15 | | ns | |
| | T _{RCS} | Chip select setup time (Read ID) | 45 | | ns | |
| | T _{RCSFM} | Chip select setup time (Read FM) | 355 | | ns | |
| | T _{CSF} | Chip select wait time (Write/Read) | 10 | | ns | |
| | T _{CSH} | Chip select hold time | 10 | | ns | |
| WRX | T _{WC} | Write cycle | 66 | | ns | |
| | T _{WRH} | Control pulse "H" duration | 15 | | ns | |
| | T _{WRL} | Control pulse "L" duration | 15 | | ns | |
| RDX (ID) | T _{RC} | Read cycle (ID) | 160 | | ns | When read ID data |
| | T _{RDH} | Control pulse "H" duration (ID) | 90 | | ns | |
| | T _{RDL} | Control pulse "L" duration (ID) | 45 | | ns | |
| RDX (FM) | T _{RCFM} | Read cycle (FM) | 450 | | ns | When read from frame memory |
| | T _{RDHF} | Control pulse "H" duration (FM) | 90 | | ns | |
| | T _{RDLFM} | Control pulse "L" duration (FM) | 355 | | ns | |
| D[17:0] | T _{DST} | Data setup time | 10 | | ns | For CL=30pF |

7.2 Reset Timing Characteristics

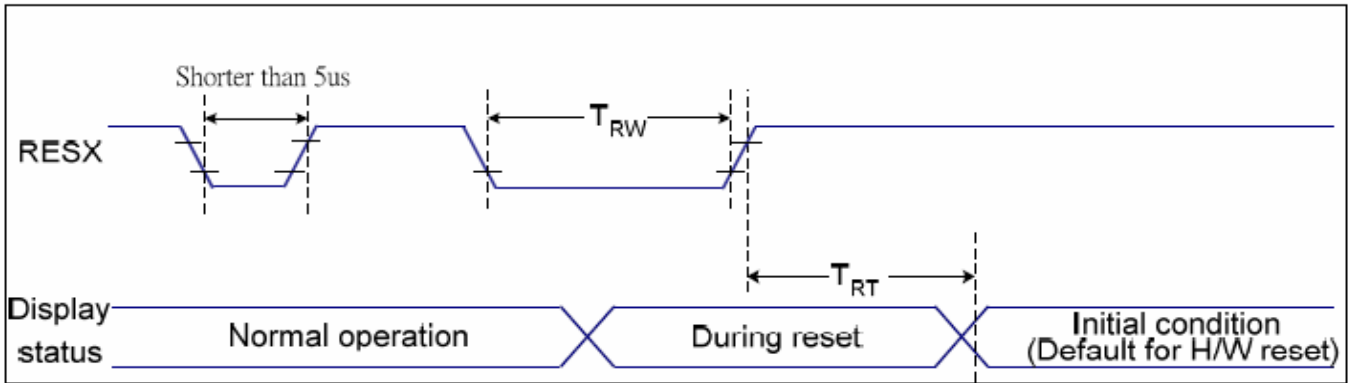

VDDI=1.65 to 3.3V, VDD=2.4 to 3.3V, AGND=DGND=0V, Ta=-30 ~ 70 °C

| Related Pins | Symbol | Parameter | MIN | MAX | Unit |
|--------------|--------|----------------------|--------------------|---------------|------|
| RESX | TRW | Reset pulse duration | 10 | - | us |
| | TRT | Reset cancel | - | 5 (Note 1, 5) | ms |
| - | | | 120 (Note 1, 6, 7) | ms | |

Notes:

1. The reset cancel includes also required time for loading ID bytes, VCOM setting and other settings from NVM (or similar device) to registers. This loading is done every time when there is HW reset cancel time (tRT) within 5 ms after a rising edge of RESX.
2. Spike due to an electrostatic discharge on RESX line does not cause irregular system reset according to the table below:

| RESX Pulse | Action |
|---------------------|----------------|
| Shorter than 5us | Reset Rejected |
| Longer than 9us | Reset |
| Between 5us and 9us | Reset starts |

3. During the Resetting period, the display will be blanked (The display is entering blanking sequence, which maximum time is 120 ms, when Reset Starts in Sleep Out –mode. The display remains the blank state in Sleep In –mode.) and then return to Default condition for Hardware Reset.

4. Spike Rejection also applies during a valid reset pulse as shown below:

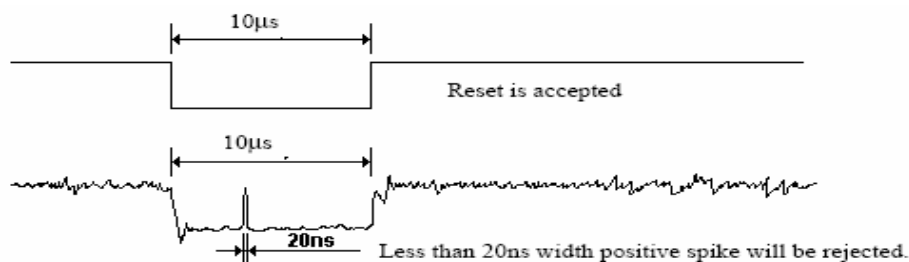

5. When Reset applied during Sleep In Mode.
6. When Reset applied during Sleep Out Mode.
7. It is necessary to wait 5msec after releasing RESX before sending commands. Also Sleep Out command cannot be sent for 120msec.

8. Backlight Characteristic

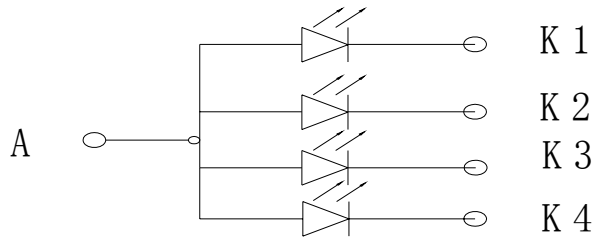

| Item | Symbol | MIN | TYP | MAX | UNIT | Test Condition |
|----------------------------|--------|-------|-------|-----|-------------------|----------------|
| Supply Voltage | Vf | 2.9 | 3.2 | 3.5 | V | If=60mA |
| Supply Current | If | - | 60 | - | mA | - |
| Luminous Intensity for LCM | - | 140 | 200 | - | Cd/m ² | If=60mA |
| Uniformity for LCM | - | 80 | - | - | % | If=60mA |
| Life Time | - | 20000 | 50000 | - | Hr | If=60mA |
| Backlight Color | White | | | | | |

9. Optical Characteristics

| Item | Conditions | Min. | Typ. | Max. | Unit | Note | |
|------------------------------------|------------|---------------|------|---------------|------|-------------|-------------|
| Viewing Angle (CR>10) | Horizontal | θ_L | - | 70 | - | degree | (1),(2),(6) |
| | | θ_R | - | 70 | - | | |
| | Vertical | θ_T | - | 70 | - | | |
| | | θ_B | - | 60 | - | | |
| Contrast Ratio | Center | 400 | 500 | - | - | (1),(3),(6) | |
| Response Time | Rising | - | 2 | 4 | ms | (1),(4),(6) | |
| | Falling | - | 6 | 12 | ms | (1),(4),(6) | |
| CF Color Chromaticity (CIE1931) | Red x | Typ. -0.05 | 0.61 | Typ. +0.05 | - | (1), (6) | |
| | Red y | | 0.34 | | - | | |
| | Green x | | 0.30 | | - | | |
| | Green y | | 0.57 | | - | | |
| | Blue x | | 0.14 | | - | | |
| | Blue y | | 0.07 | | - | | |
| | White x | | 0.27 | | - | | |
| | White y | | 0.28 | | - | | |
| Transmittance | | - | 13.5 | - | % | (1),(6) | |

Note (1) Measurement Setup: The LCD module should be stabilized at given temp. 25°C for 15 minutes to avoid abrupt temperature change during measuring. In order to stabilize the luminance, the measurement should be executed after lighting backlight for 15 minutes in a windless room.

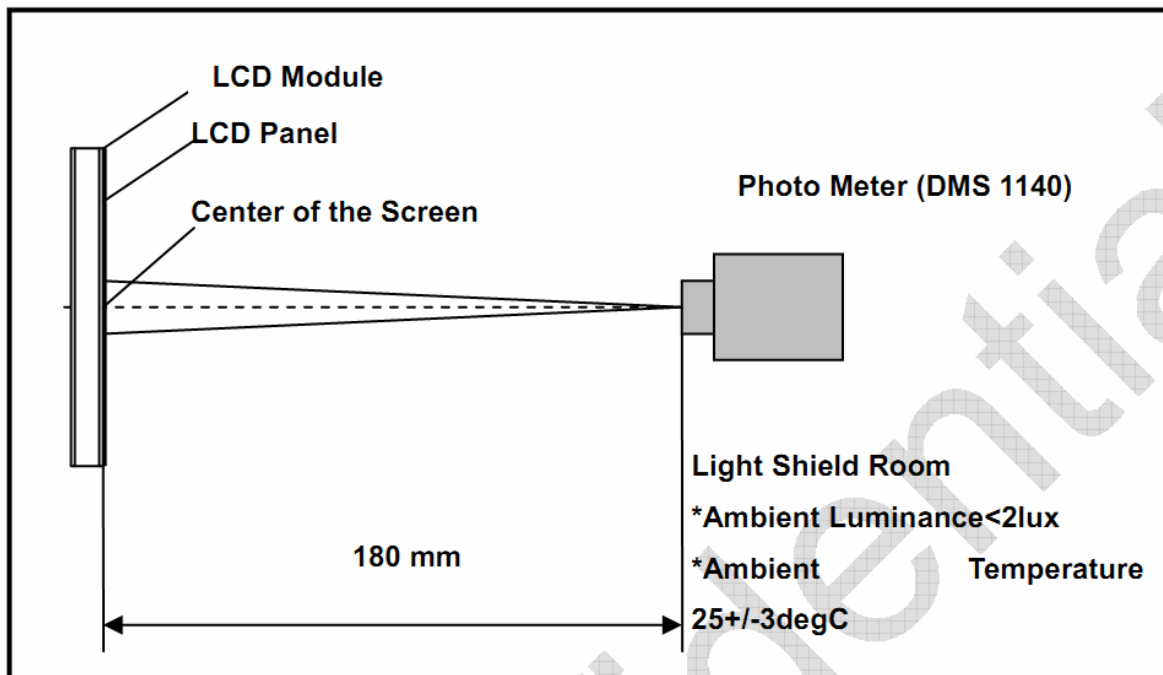

Note (2) Definition of Viewing Angle

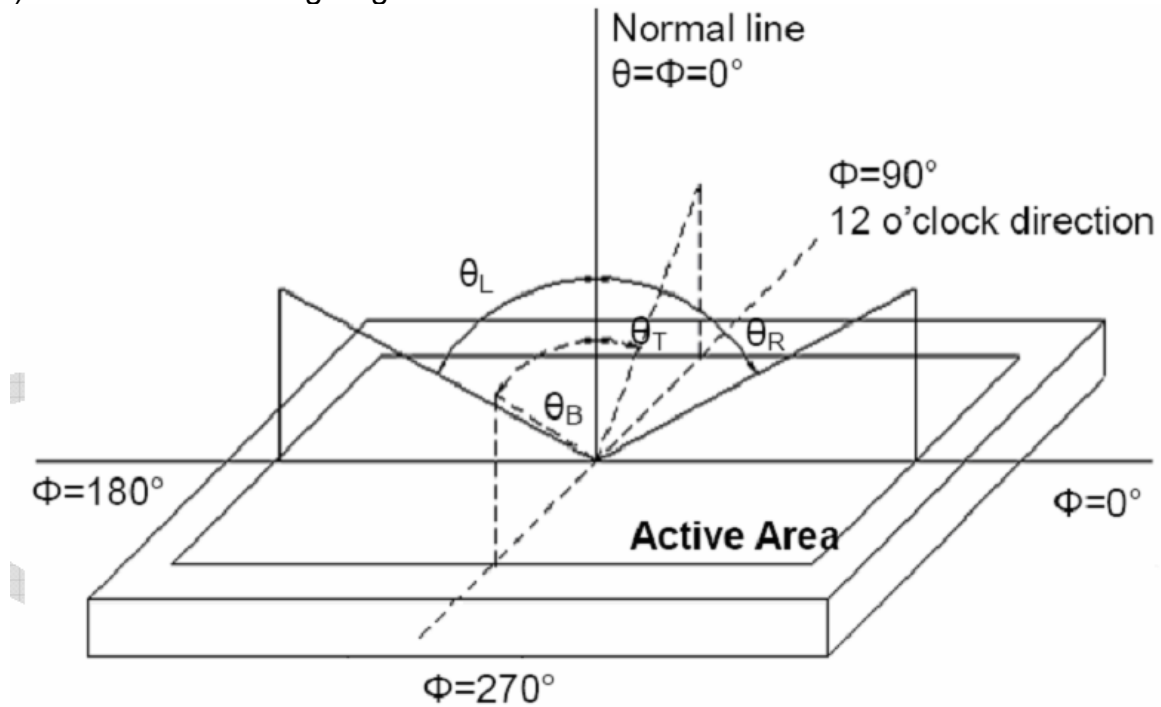

Note (3) Definition Of Contrast Ratio (CR)

The contrast ratio can be calculated by the following expression

$$\text{Contrast Ratio (CR)} = L_{63} / L_0$$

L63: Luminance of gray level 63, L0: Luminance of gray level 0

Note (4) Definition of response time

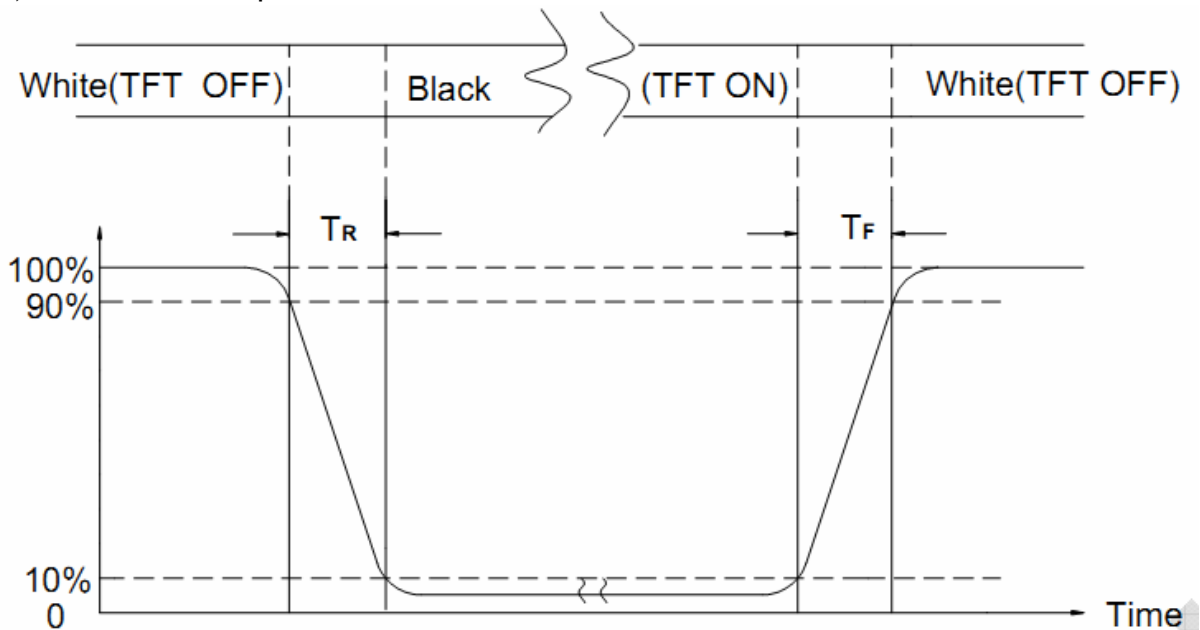

Note (5) Definition of Transmittance (Module is without signal input)

$$\text{Transmittance} = \text{Center Luminance of LCD} / \text{Center Luminance of Back Light} \times 100\%$$

Note (6) Definition of color chromaticity (CIE1931)

Color coordinates measured at the center point of LCD

10. Reliability Test Conditions and Methods

| NO. | TEST ITEMS | TEST CONDITION | INSPECTION AFTER TEST |
|-----|----------------------------|---|---|
| ① | High Temperature Storage | 80°C±2°C×200Hours | Inspection after 2~4hours storage at room temperature, the samples should be free from defects: 1, Air bubble in the LCD. 2, Seal leak. 3, Non-display. 4, Missing segments. 5, Glass crack. 6, Current IDD is twice higher than initial value. 7, The surface shall be free from damage. 8, The electric characteristic requirements shall be satisfied. |
| ② | Low Temperature Storage | -30°C±2°C×200Hours | |
| ③ | High Temperature Operating | 70°C±2°C×120Hours | |
| ④ | Low Temperature Operating | -20°C±2°C×120Hours | |
| ⑤ | Temperature Cycle(Storage) | $ \begin{array}{ccccc} -20^{\circ}\text{C} & \longleftrightarrow & 25^{\circ}\text{C} & \longleftrightarrow & 70^{\circ}\text{C} \\ (30\text{min}) & & (5\text{min}) & & (30\text{min}) \\ & \longleftarrow & & \longrightarrow & \\ & & \text{1cycle} & & \\ & & \text{Total 10cycle} & & \end{array} $ | |
| ⑥ | Damp Proof Test (Storage) | 50°C±5°C×90%RH×120Hours | |
| ⑦ | Vibration Test | Frequency:10Hz~55Hz~10Hz Amplitude:1.5M X,Y,Z direction for total 3hours (Packing Condition) | |
| ⑧ | Drooping Test | Drop to the ground from 1M height one time every side of carton. (Packing Condition) | |
| ⑨ | ESD Test | Voltage:±8KV,R:330Ω,C:150PF,Air Mode,10times | |

REMARK:

- 1, The Test samples should be applied to only one test item.
- 2, Sample side for each test item is 5~10pcs.
- 3, For Damp Proof Test, Pure water(Resistance > 10MΩ) should be used.
- 4, In case of malfunction defect caused by ESD damage, if it would be recovered to normal state after resetting, it would be judge as a good part.
- 5, EL evaluation should be accepted from reliability test with humidity and temperature: Some defects such as black spot/blemish can happen by natural chemical reaction with humidity and Fluorescence EL has.
- 6, Failure Judgment Criterion: Basic Specification Electrical Characteristic, Mechanical Characteristic, Optical Characteristic.

11. Inspection Standard

11.1. QUALITY :

THE QUALITY OF GOODS SUPPLIED TO PURCHASER SHALL COME UP TO THE FOLLOWING STANDARD.

11.1.1. THE METHOD OF PRESERVING GOODS

AFTER DELIVERY OF GOODS FROM AMSON TO PURCHASER. PURCHASER SHALL CONTROL THE LCM AT -10°C TO 40°C ,AND IT MIGHT BE DESIRABLE TO KEEP AT THE NORMAL ROOM TEMPERATURE AND HUMIDITY UNTIL INCOMING INSPECTION OR THROWING INTO PROCESS LINE.

11.1.2. INCOMING INSPECTION

(A) THE METHOD OF INSPECTION

IF PURCHASER MAKE AN INCOMING INSPECTION , A SAMPLING PLAN SHALL BE APPLIED ON THE CONDITION THAT QUALITY OF ONE DELIVERY SHALL BE REGARDED AS ONE LOT.

(B) THE STANDARD OF QUALITY

ISO-2859-1 (SAME AS MIL-STD-105E) , LEVEL II SINGLE PLAN.

| CLASS | AQL(%) |
|----------|--------|
| CRITICAL | 0.4 % |
| MAJOR | 0.65 % |
| MINOR | 1.5 % |
| TOTAL | 1.5 % |

EVERY ITEM SHALL BE INSPECTED ACCORDING TO THE CLASS.

(C) MEASURE

IF AS THE RESULT OF ABOVE RECEIVING INSPECTION , A LOT OUT IS DISCOVERED. PURCHASER SHALL BE INFORM SELLER OF IT WITHIN SEVEN DAYS. BUT FIRST SHIPMENT WITHIN FOURTEEN DAYS.

11.1.3. WARRANTY POLICY

AMSON WILL PROVIDE ONE-YEAR WARRANTY FOR THE PRODUCTS ONLY IF UNDER SPECIFICATION OPERATING CONDITIONS. AMSON WILL REPLACE NEW PRODUCTS FOR THESE DEFECT PRODUCTS WHICH UNDER WARRANTY PERIOD AND BELONG TO THE RESPONSIBILITY OF AMSON.

11.2. CHECKING CONDITION

11.2.1. CHECKING DIRECTION SHALL BE IN THE 45 DEGREE AREA TO FACE THE SAMPLE.

11.2.2. CHECKER SHALL SEE OVER 300±25 mm. WITH BARE EYES FAR FROM SAMPLE AND USING 2 PCS. OF 20W FLUORESCENT LAMP.

11.3. INSPECTION PLAN :

| CLASS | ITEM | JUDGEMENT | CLASS |
|--------------------|--|--|----------|
| PACKING & INDICATE | 1. OUTSIDE AND INSIDE PACKAGE | "MODEL NO." , "LOT NO." AND "QUANTITY" SHOULD INDICATE ON THE PACKAGE. | Minor |
| | 2. MODEL MIXED AND QUANTITY | OTHER MODEL MIXED.....REJECTED QUANTITY SHORT OR OVER.....REJECTED | Critical |
| | 3. PRODUCT INDICATION | "MODEL NO." SHOULD INDICATE ON THE PRODUCT | Major |
| ASSEMBLY | 4. DIMENSION, LCD GLASS SCRATCH AND SCRIBE DEFECT. | ACCORDING TO SPECIFICATION OR DRAWING. | Major |
| APPEARANCE | 5. VIEWING AREA | POLARIZER EDGE OR LCD'S SEALING LINE IS VISABLE IN THE VIEWING AREAREJECTED | Minor |
| | 6. BLEMISH · BLACK SPOT · WHITE SPOT IN THE LCD AND LCD GLASS CRACKS | ACCORDING TO STANDARD OF VISUAL INSPECTION(INSIDE VIEWING AREA) | Minor |
| | 7. BLEMISH · BLACK SPOT WHITE SPOT AND SCRATCH ON THE POLARIZER | ACCORDING TO STANDARD OF VISUAL INSPECTION(INSIDE VIEWING AREA) | Minor |
| | 8. BUBBLE IN POLARIZER | ACCORDING TO STANDARD OF VISUAL INSPECTION(INSIDE VIEWING AREA) | Minor |
| | 9. LCD'S RAINBOW COLOR | STRONG DEVIATION COLOR (OR NEWTON RING) OF LCD.....REJECTED. OR ACCORDING TO LIMITED SAMPLE (IF NEEDED, AND INSIDE VIEWING AREA) | Minor |
| ELECTRICAL | 10. ELECTRICAL AND OPTICAL CHARACTERISTICS (CONTRAST· VOP · CHROMATICITY ... ETC) | ACCORDING TO SPECIFICATION OR DRAWING . (INSIDE VIEWING AREA) | Critical |
| | 11.MISSING LINE | MISSING DOT · LINE · CHARACTERREJECTED | Critical |
| | 12.SHORT CIRCUIT· WRONG PATTERN DISPLAY | NO DISPLAY · WRONG PATTERN DISPLAY · CURRENT CONSUMPTION OUT OF SPECIFICATION..... REJECTED | Critical |
| | 13. DOT DEFECT (FOR COLOR AND TFT) | ACCORDING TO STANDARD OF VISUAL INSPECTION | Minor |

11.4. STANDARD OF VISUAL INSPECTION

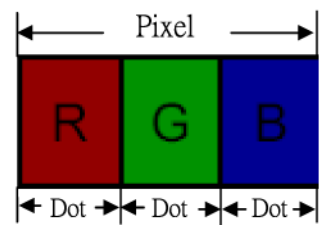
| NO. | CLASS | ITEM | JUDGEMENT | | | | | | | | | | | | | | | | | | | | |
|------------------------|---------------------------|--|---|----------------|-----------------|-----------------|---------------------------|------------------------|---------------------------|---------------|---|--------|-------|-----------------|-------|---------------|-----------|--------------|----------------------|------------------|-------|------------|-------------------|
| 11.4.1 | MINOR | BLACK AND WHITE SPOT FOREIGN MATERIEL DUST IN THE CELL BLEMISH SCRATCH | <p>(A) ROUND TYPE: unit : mm.</p> <table border="1" style="width: 100%; border-collapse: collapse;"> <thead> <tr> <th style="width: 60%;">DIAMETER (mm.)</th> <th style="width: 40%;">ACCEPTABLE Q'TY</th> </tr> </thead> <tbody> <tr> <td style="text-align: center;">$\Phi \leq 0.1$</td> <td style="text-align: center;">DISREGARD</td> </tr> <tr> <td style="text-align: center;">$0.1 < \Phi \leq 0.25$</td> <td style="text-align: center;">3 (Distance>5mm)</td> </tr> <tr> <td style="text-align: center;">$0.25 < \Phi$</td> <td style="text-align: center;">0</td> </tr> </tbody> </table> <p style="font-size: small;">NOTE: $\Phi = (\text{LENGTH} + \text{WIDTH}) / 2$</p> <p>(B) LINEAR TYPE: unit : mm.</p> <table border="1" style="width: 100%; border-collapse: collapse;"> <thead> <tr> <th style="width: 20%;">LENGTH</th> <th style="width: 30%;">WIDTH</th> <th style="width: 50%;">ACCEPTABLE Q'TY</th> </tr> </thead> <tbody> <tr> <td style="text-align: center;">-----</td> <td style="text-align: center;">$W \leq 0.03$</td> <td style="text-align: center;">DISREGARD</td> </tr> <tr> <td style="text-align: center;">$L \leq 5.0$</td> <td style="text-align: center;">$0.03 < W \leq 0.07$</td> <td style="text-align: center;">3 (Distance>5mm)</td> </tr> <tr> <td style="text-align: center;">-----</td> <td style="text-align: center;">$0.07 < W$</td> <td style="text-align: center;">FOLLOW ROUND TYPE</td> </tr> </tbody> </table> | DIAMETER (mm.) | ACCEPTABLE Q'TY | $\Phi \leq 0.1$ | DISREGARD | $0.1 < \Phi \leq 0.25$ | 3 (Distance>5mm) | $0.25 < \Phi$ | 0 | LENGTH | WIDTH | ACCEPTABLE Q'TY | ----- | $W \leq 0.03$ | DISREGARD | $L \leq 5.0$ | $0.03 < W \leq 0.07$ | 3 (Distance>5mm) | ----- | $0.07 < W$ | FOLLOW ROUND TYPE |
| DIAMETER (mm.) | ACCEPTABLE Q'TY | | | | | | | | | | | | | | | | | | | | | | |
| $\Phi \leq 0.1$ | DISREGARD | | | | | | | | | | | | | | | | | | | | | | |
| $0.1 < \Phi \leq 0.25$ | 3 (Distance>5mm) | | | | | | | | | | | | | | | | | | | | | | |
| $0.25 < \Phi$ | 0 | | | | | | | | | | | | | | | | | | | | | | |
| LENGTH | WIDTH | ACCEPTABLE Q'TY | | | | | | | | | | | | | | | | | | | | | |
| ----- | $W \leq 0.03$ | DISREGARD | | | | | | | | | | | | | | | | | | | | | |
| $L \leq 5.0$ | $0.03 < W \leq 0.07$ | 3 (Distance>5mm) | | | | | | | | | | | | | | | | | | | | | |
| ----- | $0.07 < W$ | FOLLOW ROUND TYPE | | | | | | | | | | | | | | | | | | | | | |
| 11.4.2 | MINOR | BUBBLE IN POLARIZER DENT ON POLARIZER | <p style="text-align: right;">unit : mm.</p> <table border="1" style="width: 100%; border-collapse: collapse;"> <thead> <tr> <th style="width: 60%;">DIAMETER</th> <th style="width: 40%;">ACCEPTABLE Q'TY</th> </tr> </thead> <tbody> <tr> <td style="text-align: center;">$\Phi \leq 0.2$</td> <td style="text-align: center;">DISREGARD</td> </tr> <tr> <td style="text-align: center;">$0.2 < \Phi \leq 0.5$</td> <td style="text-align: center;">2 (Distance>5mm)</td> </tr> <tr> <td style="text-align: center;">$0.5 < \Phi$</td> <td style="text-align: center;">0</td> </tr> </tbody> </table> | DIAMETER | ACCEPTABLE Q'TY | $\Phi \leq 0.2$ | DISREGARD | $0.2 < \Phi \leq 0.5$ | 2 (Distance>5mm) | $0.5 < \Phi$ | 0 | | | | | | | | | | | | |
| DIAMETER | ACCEPTABLE Q'TY | | | | | | | | | | | | | | | | | | | | | | |
| $\Phi \leq 0.2$ | DISREGARD | | | | | | | | | | | | | | | | | | | | | | |
| $0.2 < \Phi \leq 0.5$ | 2 (Distance>5mm) | | | | | | | | | | | | | | | | | | | | | | |
| $0.5 < \Phi$ | 0 | | | | | | | | | | | | | | | | | | | | | | |
| 11.4.3 | MINOR | Dot Defect | <table border="1" style="width: 100%; border-collapse: collapse;"> <thead> <tr> <th style="width: 50%;">Items</th> <th style="width: 50%;">ACC. Q'TY</th> </tr> </thead> <tbody> <tr> <td>Bright dot</td> <td style="text-align: center;">$N \leq 4$ (Distance>5mm)</td> </tr> <tr> <td>Dark dot</td> <td style="text-align: center;">$N \leq 4$ (Distance>5mm)</td> </tr> </tbody> </table> <p>Pixel Define :</p> <div style="text-align: center;">  </div> <p>Note 1: The definition of dot: The size of a defective dot over 1/2 of whole dot is regarded as one defective dot.</p> <p>Note 2: Bright dot: Dots appear bright and unchanged in size in which LCD panel is displaying under black pattern.</p> <p>Note 3: Dark dot: Dots appear dark and unchanged in size in which LCD panel is displaying under pure red, green, blue pattern.</p> | Items | ACC. Q'TY | Bright dot | $N \leq 4$ (Distance>5mm) | Dark dot | $N \leq 4$ (Distance>5mm) | | | | | | | | | | | | | | |
| Items | ACC. Q'TY | | | | | | | | | | | | | | | | | | | | | | |
| Bright dot | $N \leq 4$ (Distance>5mm) | | | | | | | | | | | | | | | | | | | | | | |
| Dark dot | $N \leq 4$ (Distance>5mm) | | | | | | | | | | | | | | | | | | | | | | |

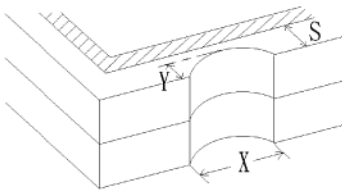
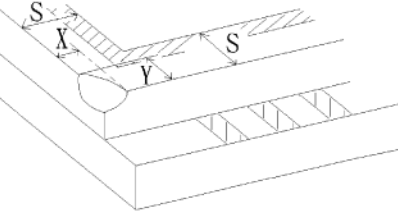
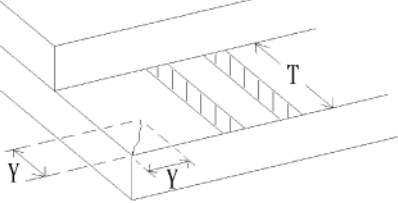
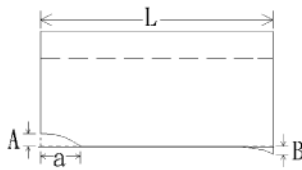
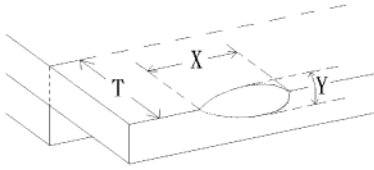
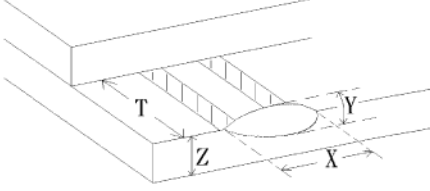
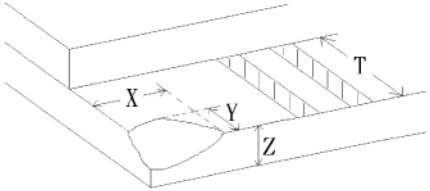
| NO. | CLASS | ITEM | JUDGEMENT |
|---------|-------|--|---|
| 11.4.4 | MINOR | LCD GLASS CHIPPING |  $Y > S$ Reject |
| 11.4.5 | MINOR | LCD GLASS CHIPPING |  $X \text{ or } Y > S$ Reject |
| 11.4.6 | MAJOR | LCD GLASS GLASS CRACK |  $Y > (1/2) T$ Reject |
| 11.4.7 | MAJOR | LCD GLASS SCRIBE DEFECT |  <ol style="list-style-type: none"> $a > L/3$, $A > 1.5\text{mm}$. Reject B: ACCORDING TO DIMENSION |
| 11.4.8 | MINOR | LCD GLASS CHIPPING (ON THE TERMINAL AREA) |  $\Phi = (x+y)/2 > 2.5 \text{ mm}$ Reject |
| 11.4.9 | MINOR | LCD GLASS CHIPPING (ON THE TERMINAL SURFACE) |  $Y > (1/3) T$ Reject |
| 11.4.10 | MINOR | LCD GLASS CHIPPING |  $Y > T$ Reject |

12. Handling Precautions

12.1 Mounting method

The LCD panel of AMSON TFT module consists of two thin glass plates with polarizers which easily be damaged. And since the module is so constructed as to be fixed by utilizing fitting holes in the printed circuit board.

Extreme care should be needed when handling the LCD modules.

12.2 Caution of LCD handling and cleaning

When cleaning the display surface, Use soft cloth with solvent

[Recommended below] and wipe lightly

- Isopropyl alcohol
- Ethyl alcohol

Do not wipe the display surface with dry or hard materials that will damage the polarizer surface.

Do not use the following solvent:

- Water
- Aromatics

Do not wipe ITO pad area with the dry or hard materials that will damage the ITO patterns

Do not use the following solvent on the pad or prevent it from being contaminated:

- Soldering flux
- Chlorine (Cl) , Sulfur (S)

If goods were sent without being silicon coated on the pad, ITO patterns could be damaged due to the corrosion as time goes on.

If ITO corrosion happens by miss-handling or using some materials such as Chlorine (Cl), Sulfur (S) from customer, Responsibility is on customer.

12.3 Caution against static charge

The LCD module uses C-MOS LSI drivers, so we recommend that you:

Connect any unused input terminal to POWER or GROUND, do not input any signals before power is turned on, and ground your body, work/assembly areas, and assembly equipment to protect against static electricity.

12.4 packing

- Module employs LCD elements and must be treated as such.
- Avoid intense shock and falls from a height.
- To prevent modules from degradation, do not operate or store them exposed direct to sunshine or high temperature/humidity

12.5 Caution for operation

- It is an indispensable condition to drive LCD's within the specified voltage limit since the higher voltage than the limit causes the shorter LCD life.
- An electrochemical reaction due to direct current causes LCD's undesirable deterioration, so that the use of direct current drive should be avoided.
- Response time will be extremely delayed at lower temperature than the operating temperature range and on the other hand at higher temperature LCD's show dark color in them. However those phenomena do not mean malfunction or out of order with LCD's, which will come back in the specified operation temperature.
- If the display area is pushed hard during operation, some font will be abnormally displayed but it resumes normal condition after turning off once.
- Slight dew depositing on terminals is a cause for electro-chemical reaction resulting in terminal open circuit.

Usage under the maximum operating temperature, 50%Rh or less is required.

12.6 storing

In the case of storing for a long period of time for instance, for years for the purpose or replacement use, the following ways are recommended.

- Storage in a polyethylene bag with the opening sealed so as not to enter fresh air outside in it. And with no desiccant.
- Placing in a dark place where neither exposure to direct sunlight nor light's keeping the storage temperature range.
- Storing with no touch on polarizer surface by the anything else.
[It is recommended to store them as they have been contained in the inner container at the time of delivery from us

12.7 Safety

- It is recommendable to crash damaged or unnecessary LCD's into pieces and wash off liquid crystal by either of solvents such as acetone and ethanol, which should be burned up later.
- When any liquid leaked out of a damaged glass cell comes in contact with your hands, please wash it off well with soap and water

13. Precaution for Use

13.1

A limit sample should be provided by the both parties on an occasion when the both parties agreed its necessity. Judgment by a limit sample shall take effect after the limit sample has been established and confirmed by the both parties.

13.2

On the following occasions, the handing of problem should be decided through discussion and agreement between responsible of the both parties.

- When a question is arisen in this specification
- When a new problem is arisen which is not specified in this specifications
- When an inspection specifications change or operating condition change in customer is reported to AMSON TFT , and some problem is arisen in this specification due to the change
- When a new problem is arisen at the customer's operating set for sample evaluation in the customer site.

14. Packing Method

TBD