

# SPECIFICATIONS FOR LCD MODULE

<b>CUSTOMER</b>	
<b>CUSTOMER PART NO.</b>	
<b>AMPIRE PART NO.</b>	<b>AM-320240LATNQW-00H</b>
<b>APPROVED BY</b>	
<b>DATE</b>	

- Approved For Specifications**  
 **Approved For Specifications & Sample**

APPROVED BY	CHECKED BY	ORGANIZED BY

## RECORD OF REVISION

<b>Revision Date</b>	<b>Page</b>	<b>Contents</b>	<b>Editor</b>
2008/9/9	--	New Release.	Edward
2008/9/22	--	Rename to official P/N AM-320240LATNQW-00H	Edward
	14	Update the brightness to 500 cd/m2(typ.)	Edward
	14	Modify the range of C.I.E coordinates	Edward

## 1 General Description and Features

3.5 inch Amorphous-TFT-LCD (Thin Film Transistor Liquid Crystal Display) module. This module is composed of a 3.5" TFT-LCD panel, a driver circuit and backlight unit.

- 1.1 Construction: 3.5" a-Si color TFT-LCD, White LED Backlight and PCB.
- 1.2 Resolution (pixel): 320(R.G.B) X240.
- 1.3 Number of the Colors: 262K colors (R, G, B 6 bit digital each).
- 1.4 LCD type: Transmissive Color TFT LCD (normally White).
- 1.5 View Angle: 12 o'clock
- 1.6 18-Bit RGB Interface.
- 1.7 Interface: 40 pin.
- 1.8 Support SYNC Mode Only.
- 1.9 Power Supply Voltage: 3.3V single power input. Built-in power supply circuit.
- 1.10 LED Type Backlight.

## 2 Physical specifications

Item	Specifications	unit
Display Resolution	320(W) x 240(H)	dot
Active area	70.08 x 52.56	mm
Screen size	3.5(Diagonal)	inch
Dot pitch	0.073 (W) x 0.219 (H)	mm
Color configuration	R.G.B – stripe	
Overall Dimension	77.8(W) x 66.0(H) x 4.4(T)	mm
Input interface	digital 18-bits RGB	
Surface Treatment	Anti - glare(AG)	
Backlight unit	White LED	
Display Mode	Normally White/Transmissive	

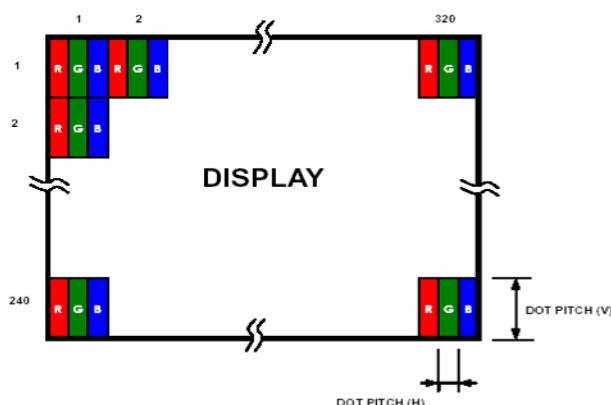

### 3 Functional Block Diagram

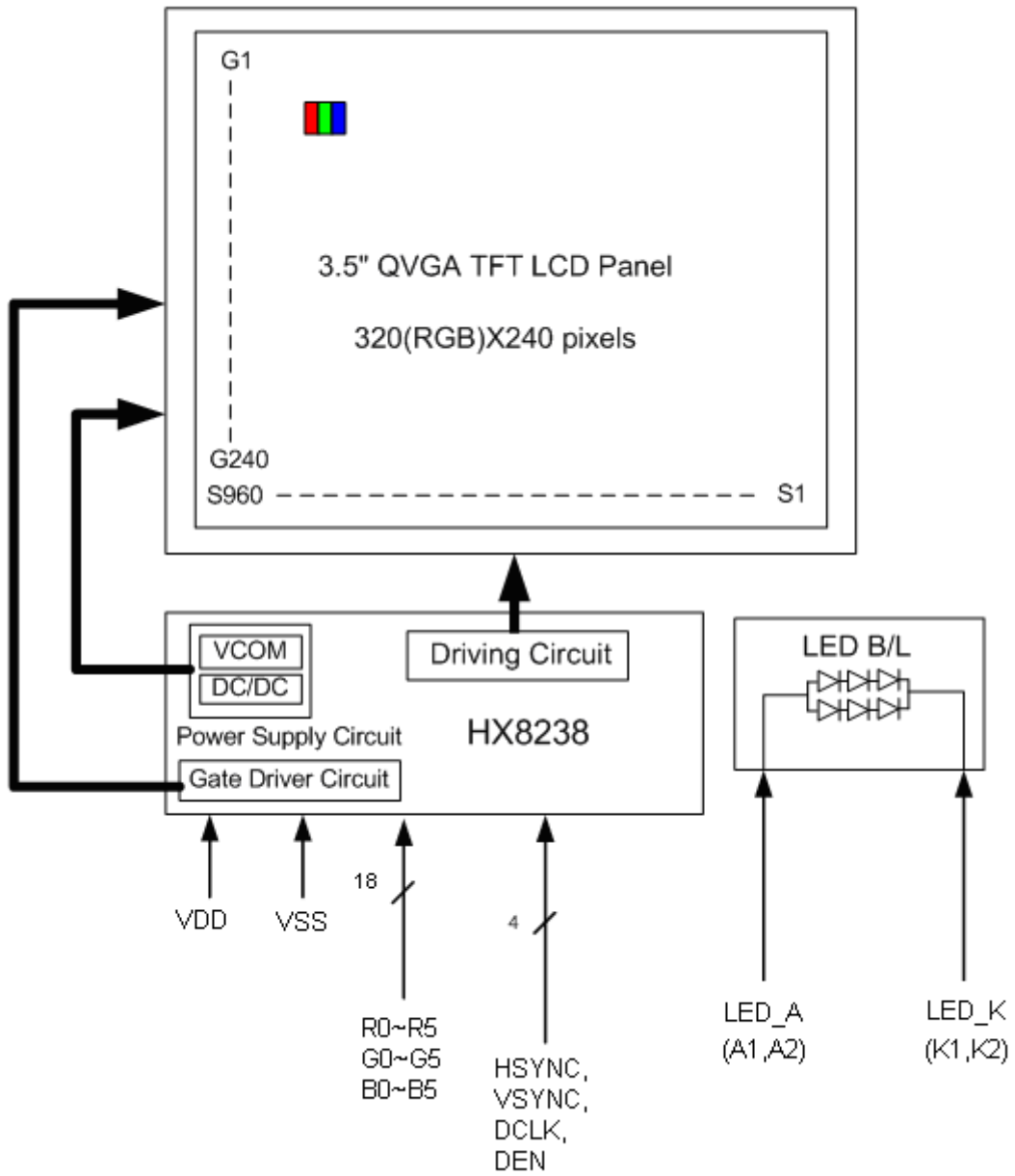

## 4 Electrical Specifications

### TFT LCD Panel FPC Descriptions

Pin no	Symbol	I/O	Description	Remark
1~4	VDD		Power supply for the logic (3.3V)	
5	Hsync	I	Horizontal sync input in digital RGB mode	
6	DEN		Keep this Pin NC.	
7	VSS		GND	
8	DCLK	I	Clock signal. Latching data at the rising edge.	
9	VSS		GND	
10	Vsync	I	Vertical sync input in digital RGB mode.	
11	VSS		GND	
12	B5	I	Blue data	
13	B4	I		
14	B3	I		
15	VSS		GND	
16	B2	I	Blue data	
17	B1	I		
18	B0	I		
19	VSS		GND	
20	G5	I	Green data	
21	G4	I		
22	G3	I		
23	VSS		GND	
24	G2	I	Green data	
25	G1	I		
26	G0	I		
27	VSS		GND	
28	R5	I	Red data	
29	R4	I		
30	R3	I		
31	VSS		GND	
32	R2	I	Red data	
33	R1	I		
34	R0	I		
35	NC	I	Not use	
36	VSS		GND	
37	YU / A1	I	1.Backlight AK pin(without touch panel function) 2.Touch panel control pin(Backlight AK are driven by LED Driver circuit)	
38	XL / A2	I		
39	YD / K1	I		
40	XR / K2	I		

## 5 Basic Display Color and Gray Scale

	Color & Gray Scale	DATA SIGNAL																	
		R5	R4	R3	R2	R1	R0	G5	G4	G3	G2	G1	G0	B5	B4	B3	B2	B1	B0
Basic Color	Black	0	0	0	0	0	0	0	0	0	0	0	0	0	0	0	0	0	0
	Red(0)	1	1	1	1	1	1	0	0	0	0	0	0	0	0	0	0	0	0
	Green(0)	0	0	0	0	0	0	1	1	1	1	1	1	0	0	0	0	0	0
	Blue(0)	0	0	0	0	0	0	0	0	0	0	0	0	1	1	1	1	1	1
	Cyan	0	0	0	0	0	0	1	1	1	1	1	1	1	1	1	1	1	1
	Magenta	1	1	1	1	1	1	0	0	0	0	0	0	1	1	1	1	1	1
	Yellow	1	1	1	1	1	1	1	1	1	1	1	1	0	0	0	0	0	0
	White	1	1	1	1	1	1	1	1	1	1	1	1	1	1	1	1	1	1
Red	Black	0	0	0	0	0	0	0	0	0	0	0	0	0	0	0	0	0	0
	Red(62)	0	0	0	0	0	1	0	0	0	0	0	0	0	0	0	0	0	0
	Red(61)	0	0	0	0	1	0	0	0	0	0	0	0	0	0	0	0	0	0
	:	:	:	:	:	:	:	:	:	:	:	:	:	:	:	:	:	:	:
	Red(31)	0	1	1	1	1	1	0	0	0	0	0	0	0	0	0	0	0	0
	:	:	:	:	:	:	:	:	:	:	:	:	:	:	:	:	:	:	:
	Red(1)	1	1	1	1	1	0	0	0	0	0	0	0	0	0	0	0	0	0
	Red(0)	1	1	1	1	1	1	0	0	0	0	0	0	0	0	0	0	0	0
Green	Black	0	0	0	0	0	0	0	0	0	0	0	0	0	0	0	0	0	0
	Green(62)	0	0	0	0	0	0	0	0	0	0	0	1	0	0	0	0	0	0
	Green(61)	0	0	0	0	0	0	0	0	0	0	0	1	0	0	0	0	0	0
	:	:	:	:	:	:	:	:	:	:	:	:	:	:	:	:	:	:	:
	Green(31)	0	0	0	0	0	0	0	1	1	1	1	0	0	0	0	0	0	0
	:	:	:	:	:	:	:	:	:	:	:	:	:	:	:	:	:	:	:
	Green(1)	0	0	0	0	0	0	1	1	1	1	1	0	0	0	0	0	0	0
	Green(0)	0	0	0	0	0	0	1	1	1	1	1	1	0	0	0	0	0	0
Blue	Black	0	0	0	0	0	0	0	0	0	0	0	0	0	0	0	0	0	0
	Blue(62)	0	0	0	0	0	0	0	0	0	0	0	0	0	0	0	0	0	1
	Blue(61)	0	0	0	0	0	0	0	0	0	0	0	0	0	0	0	0	0	1
	:	:	:	:	:	:	:	:	:	:	:	:	:	:	:	:	:	:	:
	Blue(31)	0	0	0	0	0	0	0	0	0	0	0	0	0	1	1	1	1	1
	:	:	:	:	:	:	:	:	:	:	:	:	:	:	:	:	:	:	:
	Blue(1)	0	0	0	0	0	0	0	0	0	0	0	0	1	1	1	1	1	0
	Blue(0)	0	0	0	0	0	0	0	0	0	0	0	0	1	1	1	1	1	1

## 6 Absolute Maximum Ratings

If the operating condition exceeds the following absolute maximum ratings, the TFT LCD module may be damaged permanently.

### 6.1 Environmental Absolute max. ratings

Item	OPERATING		STORAGE		Remark
	MIN	MAX	MIN	MAX	
Temperature	-20	70	-30	80	Note2,3,4,5,6,7,8
Humidity	Note1		Note1		
Corrosive Gas	Not Acceptable		Not Acceptable		

Note1 :  $T_a \leq 40^\circ\text{C}$  : 85% RH max

$T_a > 40^\circ\text{C}$  : Absolute humidity must be lower than the humidity of 85%RH at  $40^\circ\text{C}$

Note2 : For storage condition  $T_a$  at  $-30^\circ\text{C} < 48\text{h}$  , at  $80^\circ\text{C} < 100\text{h}$

For operating condition  $T_a$  at  $-20^\circ\text{C} < 100\text{h}$

Note3 : Background color changes slightly depending on ambient temperature. This phenomenon is reversible.

Note4 : The response time will be slower at low temperature.

Note5 : Only operation is guaranteed at operating temperature. Contrast , response time, another display quality are evaluated at  $+25^\circ\text{C}$

Note6 : When LCM is operated over  $40^\circ\text{C}$  ambient temperature, the  $I_{\text{LED}}$  of the LED back-light should be follow :

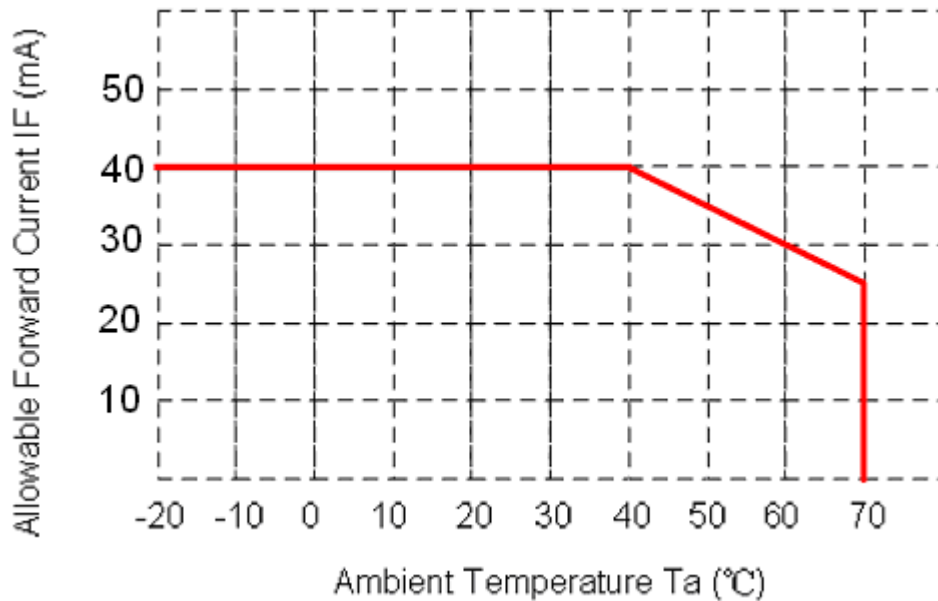

Note7 : This is panel surface temperature, not ambient temperature.

Note8 : When LCM be operated over than  $40^\circ\text{C}$  , the life time of the LED back-light will be reduced.

## 6.2 Electrical Absolute max. ratings

Item	Symbol	Condition	Min.	Max.	Unit	Remark
Power voltage	VDD	VSS=0	-0.3	6.0	V	
Input voltege	V <sub>in</sub>		-0.3	VDD+0.3	V	Note 1

Note1:Hsync, Vsync, DEN, DCLK, R0~R5, G0~G5, B0~B5

## 7 Electrical Characteristics

### 7.1 DC Electrical characteristic of the LCD

Typical operting conditions (VSS=0V)

Item	Symbol	Min.	Typ.	Max.	Unit	Remark
Power supply	VDD	3.0	3.3	3.6	V	
Input Voltage for logic	H Level	V <sub>IH</sub>	0.7 VDD	-	VDD	V
	L Level	V <sub>IL</sub>	0	-	0.3 VDD	
Power Supply current	IDD		(T.B.D)	--	mA	Note 2

Note1: Hsync, Vsync, DEN, DCLK, R0~R5, G0~G5, B0~B5

Note2: f<sub>v</sub> =60Hz , Ta=25°C , Display pattern : All Black

### 7.2 Electrical characteristic of LED Back-light

Paramenter	Symbol	Min.	Typ.	Max.	Unit	Condition
LED voltage	V <sub>AK</sub>	9.6	-	11	V	I <sub>LED</sub> =40mA, Ta=25°C
LED forward current	I <sub>LED</sub>	--	40	-	mA	Ta=25°C
	I <sub>LED</sub>	--	30	-	mA	Ta=60°C

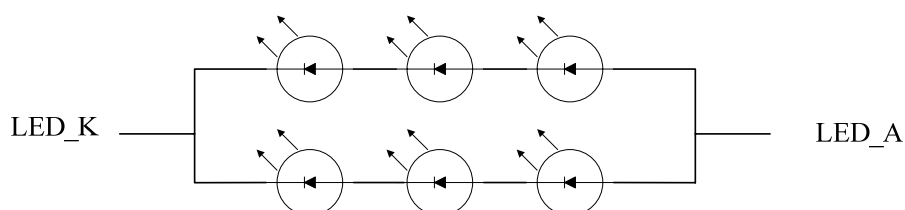



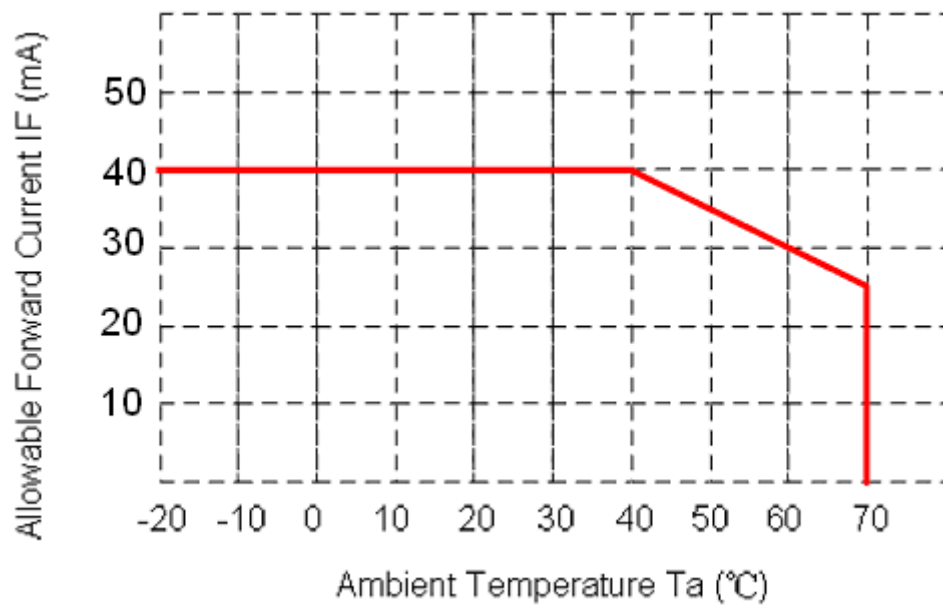

## 8 AC Timing characteristic of the LCD

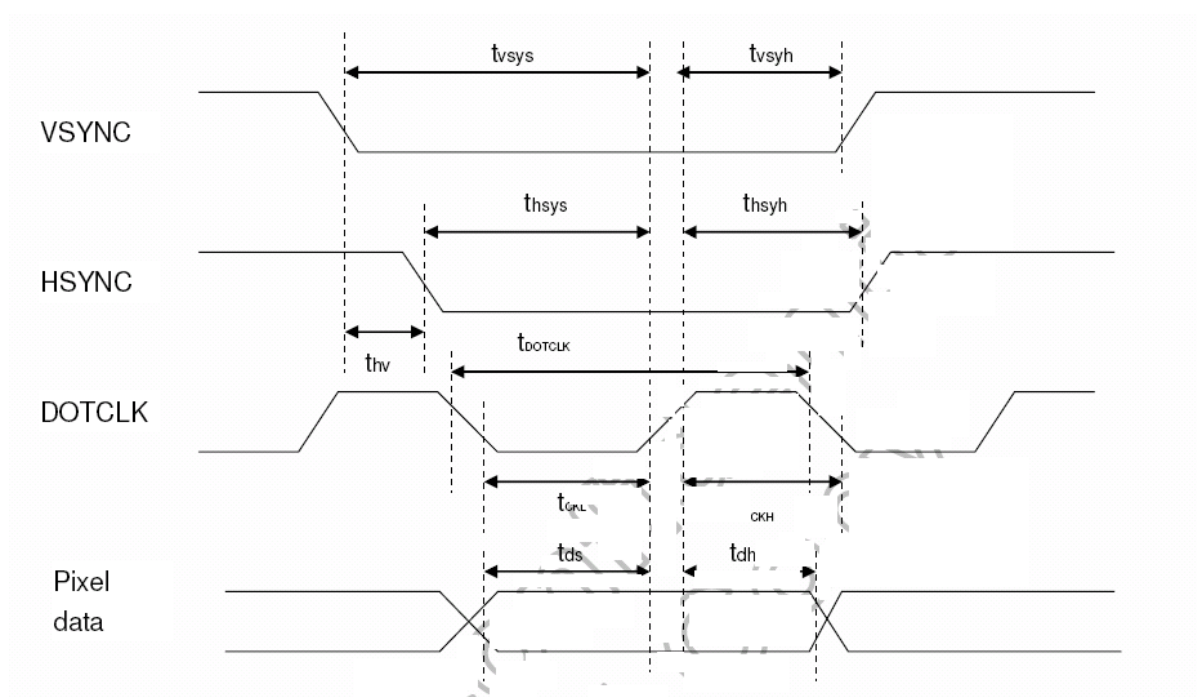

Characteristics	Symbol	Min		Typ		Max		Unit
		24 bit	8 bit	24 bit	8 bit	24 bit	8 bit	
DOTCLK Frequency	f <sub>DOTCLK</sub>	-	-	6.5	19.5	10	30	MHz
DOTCLK Period	t <sub>DOTCLK</sub>	100	33.3	154	51.3	-	-	ns
Vertical Sync Setup Time	t <sub>vsys</sub>	20	10	-	-	-	-	ns
Vertical Sync Hold Time	t <sub>vsyh</sub>	20	10	-	-	-	-	ns
Horizontal Sync Setup Time	t <sub>hsys</sub>	20	10	-	-	-	-	ns
Horizontal Sync Hold Time	t <sub>hsyh</sub>	20	10	-	-	-	-	ns
Phase difference of Sync Signal Falling Edge	t <sub>nv</sub>	1		-		240		t <sub>DOTCLK</sub>
DOTCLK Low Period	t <sub>CKL</sub>	50	15	-	-	-	-	ns
DOTCLK High Period	t <sub>CKH</sub>	50	15	-	-	-	-	ns
Data Setup Time	t <sub>ds</sub>	12	10	-	-	-	-	ns
Data hold Time	t <sub>dh</sub>	12	10	-	-	-	-	ns
Reset pulse width	t <sub>RES</sub>	10		-		-		us

**Note:** External clock source must be provided to DOTCLK pin of HX8238-A. The driver will not operate if absent of the clocking signal.

Pixel Timing Table

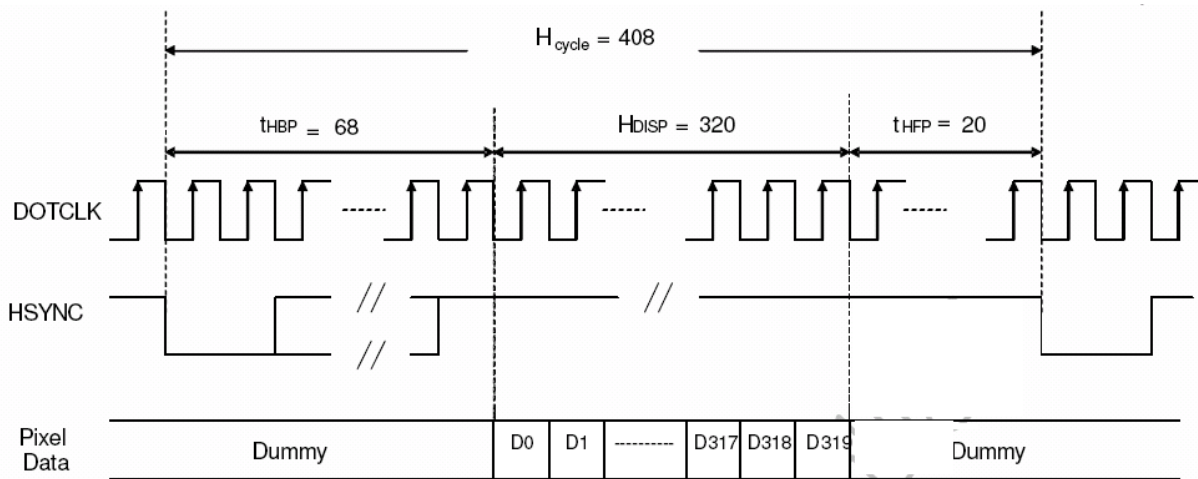

a ) Horizontal Data Transaction Timing

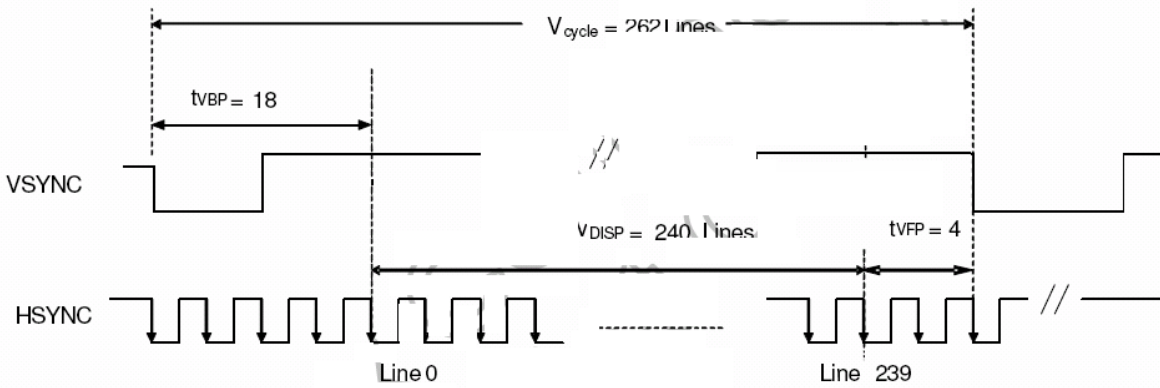

b ) Vertical Data Transaction Timing

(a) Data Transaction Timing in Parallel RGB (24 bit) Interface (SYNC Mode)

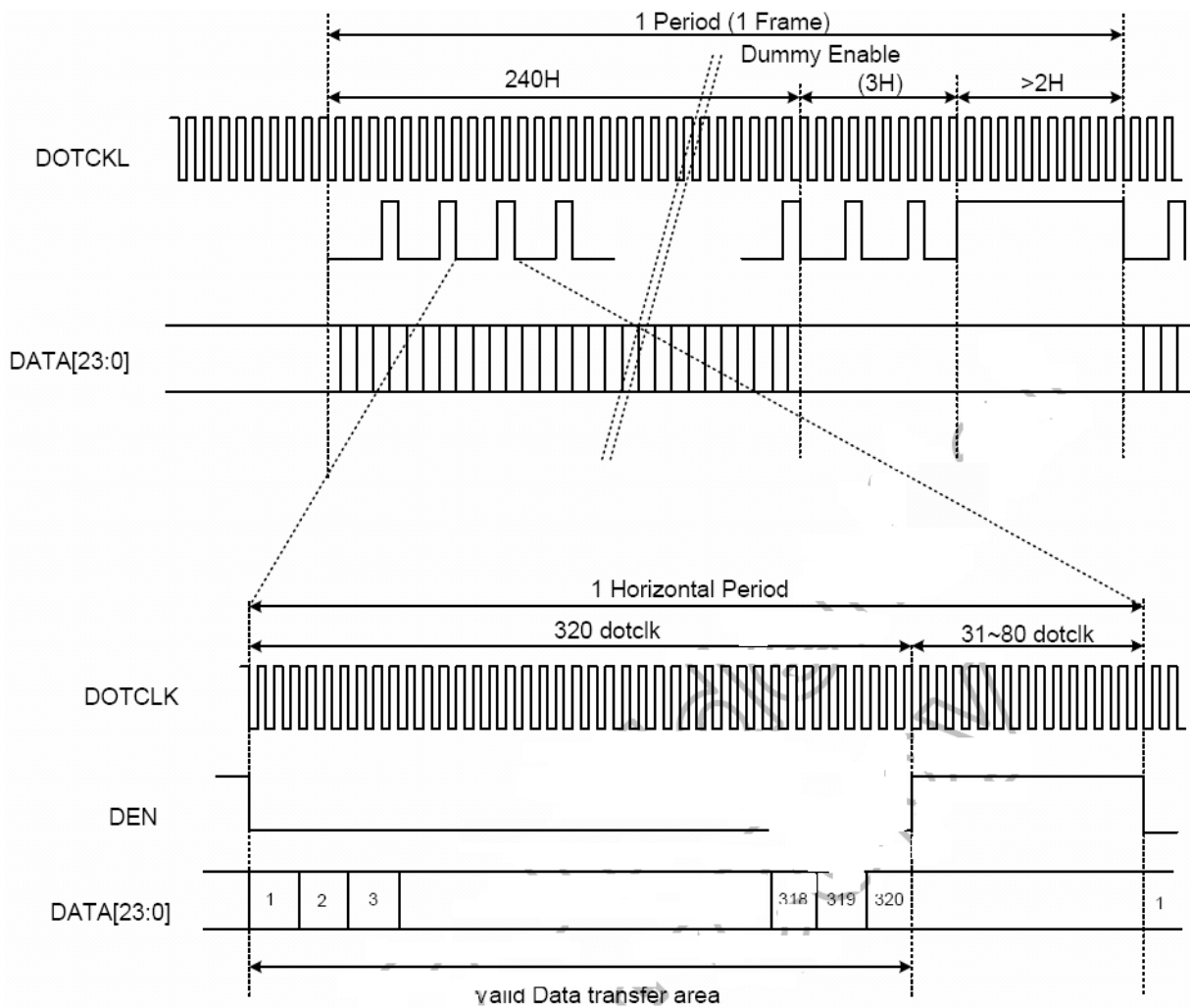

b) Data Transaction Timing in Parallel RGB (24 bit) Interface (DE Mode)

Characteristics	Symbol	Min		Typ		Max		Unit
		24 bit	8 bit	24 bit	8 bit	24 bit	8 bit	
DOTCLK Frequency	f <sub>DOTCLK</sub>	-	-	6.5	19.5	10	30	MHz
DOTCLK Period	t <sub>DOTCLK</sub>	100	33.3	154	51.3	-	-	ns
Horizontal Frequency (Line)	f <sub>H</sub>	-	-	14.9	-	22.35	-	KHz
Vertical Frequency (Refresh)	f <sub>V</sub>	-	-	60	-	90	-	Hz
Horizontal Back Porch	t <sub>HBP</sub>	-	-	68	204	-	-	t <sub>DOTCLK</sub>
Horizontal Front Porch	t <sub>HFP</sub>	-	-	20	60	-	-	t <sub>DOTCLK</sub>
Horizontal Data Start Point	t <sub>HBP</sub>	-	-	68	204	-	-	t <sub>DOTCLK</sub>
Horizontal Blanking Period	t <sub>HBP</sub> + t <sub>HFP</sub>	-	-	88	264	-	-	t <sub>DOTCLK</sub>
Horizontal Display Area	H <sub>DISP</sub>	-	-	320	960	-	-	t <sub>DOTCLK</sub>
Horizontal Cycle	H <sub>cycle</sub>	-	-	408	1224	450	1350	t <sub>DOTCLK</sub>
Vertical Back Porch	t <sub>VBP</sub>	-	-	18	-	-	-	Lines
Vertical Front Porch	t <sub>VFP</sub>	-	-	4	-	-	-	Lines
Vertical Data Start Point	t <sub>VBP</sub>	-	-	18	-	-	-	Lines
Vertical Blanking Period	t <sub>VBP</sub> + t <sub>VFP</sub>	-	-	22	-	-	-	Lines
Vertical Display Area	NTSC	-	-	240	-	-	-	Lines
	PAL			280(PALM=0)				
				288(PALM=1)				
Vertical Cycle	NTSC	-	-	262	-	350	-	Lines
	PAL			313				

Data Transaction Timing in Normal Operating Mode

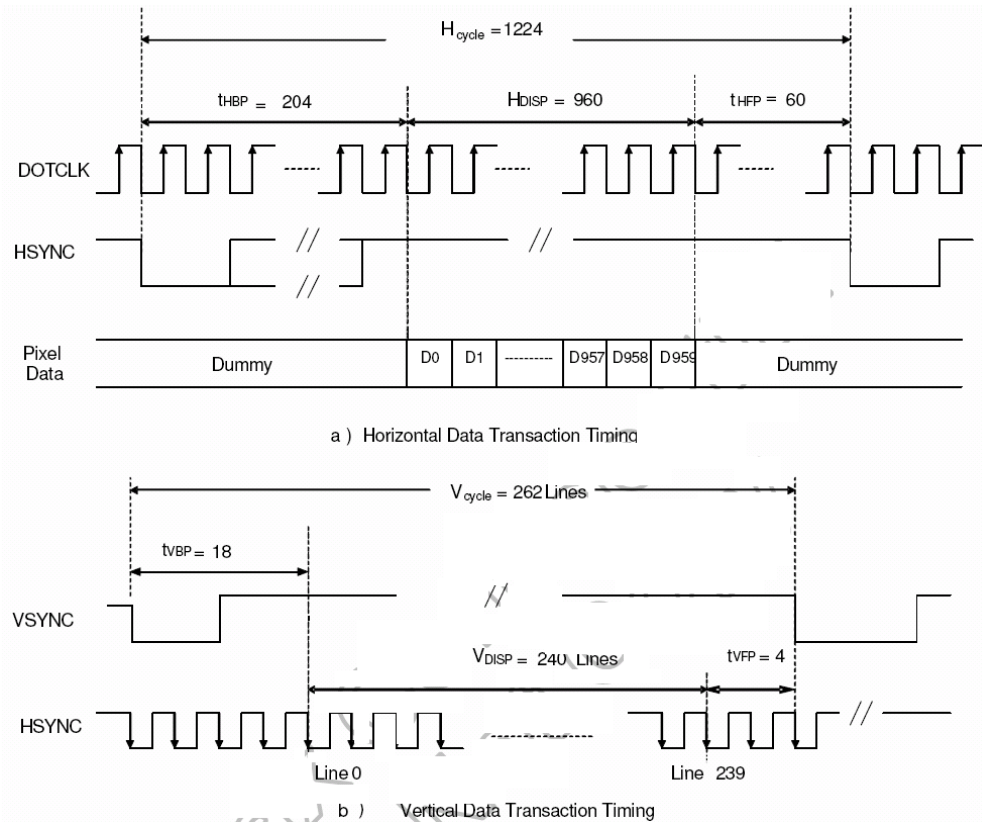

Data Transaction Timing in Serial RGB (8 bit) Interface (SYNC Mode)

## 9 Optical specification

### 9.1 Optical characteristic of the LCD

Item	Symbol	Conditon	Min.	Typ.	Max.	Unit	Remark
Response Time	$T_r+T_f$	$\Theta=0^\circ$		50	80	ms	Note 1,2,3,5
Contrast ratio	CR	At optimized viewing angle	-	300	-		Note 1,2,4,5
Viewing Angle	Top	$CR \geq 10$	-	70	-	deg.	Note1,2, 5,6
	Bottom		-	70	-		
	Left		-	80	-		
	Right		-	80	-		
Brightness	$Y_L$	$I_{LED}=40mA$ $,25^\circ C$	-	500	-	$cd/m^2$	Note 7
White chromaticity	XW		0.25	-	0.35		
	YW		0.26	-	0.36		

( ) For reference only. These data should be update according the prototype.

Note 1: Note 1: Ambient temperature= $25^\circ C$ , and lamp current  $I_{LED}=20mA$ . To be measured in the dark room.

Note 2: To be measured on the center area of panel with a viewing cone of  $1^\circ$  by Topcon luminance meter BM-7, after 10 minutes operation.

Note 3. Definition of response time:

The output signals of photo detector are measured when the input signals are changed from "black" to "white" (falling time) and from "white" to "black" (rising time), respectively. The response time is defined as the time interval between the 10% and 90% of amplitudes. Refer to figure as below.

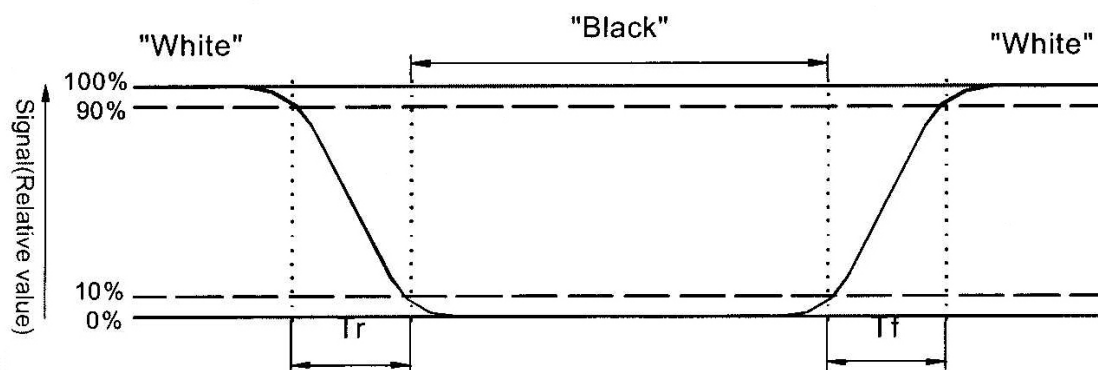

Note 4. Definition of contrast ratio:

Contrast ratio is calculated with the following formula.

$$\text{Contrast ratio (CR)} = \frac{\text{Photo detector output when LCD is at "White" state}}{\text{Photo detector Output when LCD is at "Black" state}}$$

Note 5: White  $V_i = V_{i50} + 1.5V$

Black  $V_i = V_{i50} + 2.0V$

“±” means that the analog input signal swings in phase with  $V_{COM}$  signal.

“ $\frac{-}{+}$ ” means that the analog input signal swings out of phase with  $V_{COM}$  signal.

$V_{i50}$  : The analog input voltage when transmission is 50%. The 100% Transmission is defined as the transmission of LCD panel when all the Input terminals of module are electrically opened.

Note 6. Definition of viewing angle, Refer to figure as below.

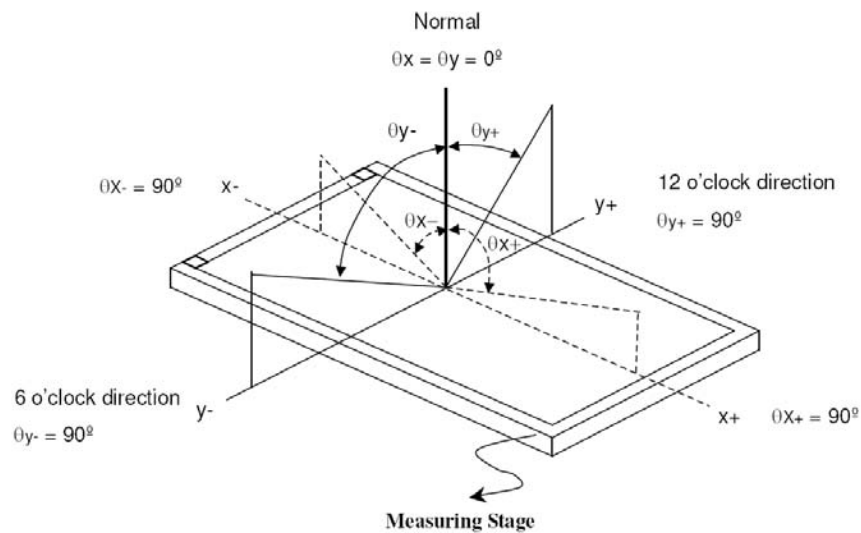

Note 7. Measured at the center area of the panel when all the input terminals of LCD panel are electrically opened.

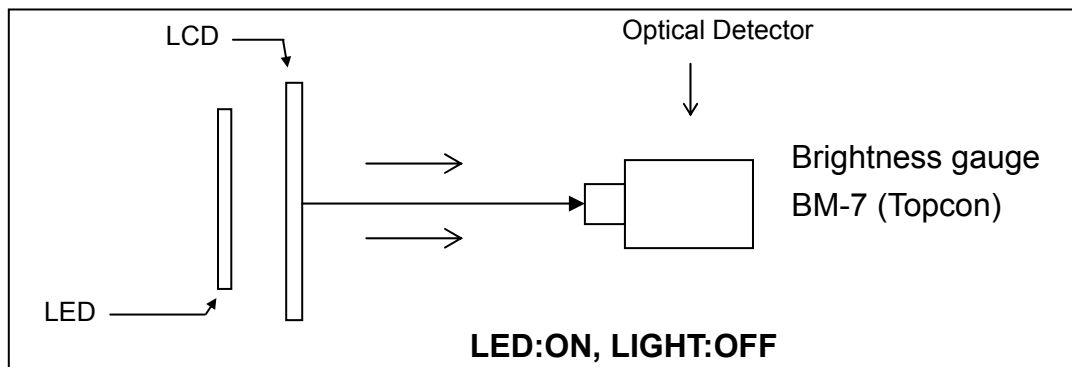
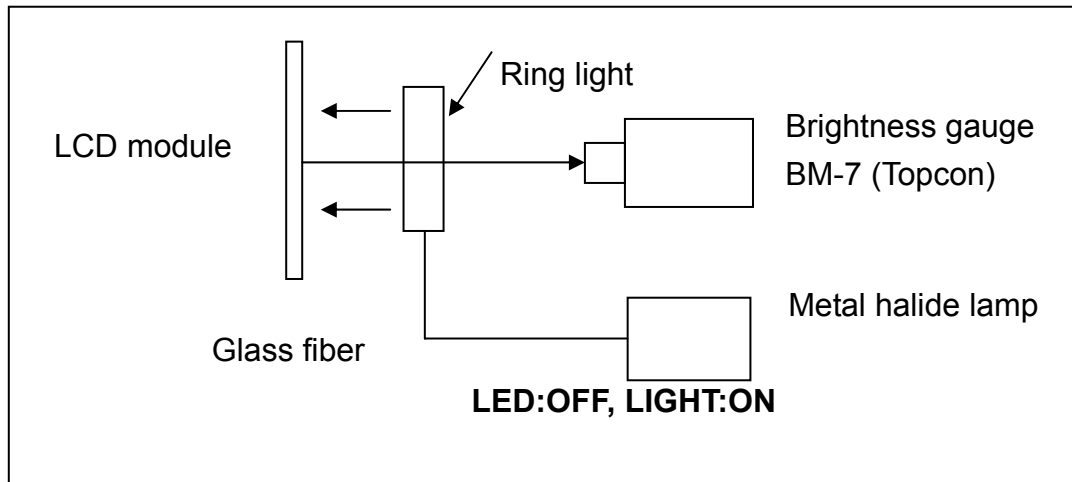



## 10 QUALITY AND RELIABILITY

### 10.1 TEST CONDITIONS

Tests should be conducted under the following conditions:

Ambient temperature:  $25 \pm 5^{\circ}\text{C}$

Humidity :  $60 \pm 25\% \text{ RH}$ .

### 10.2 SAMPLING PLAN

Sampling method shall be in accordance with MIL-STD-105E, level II, normal single sampling plan .

### 10.3 ACCEPTABLE QUALITY LEVEL

A major defect is defined as one that could cause failure to or materially reduce the usability of the unit for its intended purpose. A minor defect is one that does not materially reduce the usability of the unit for its intended purpose or is an infringement from established standards and has no significant bearing on its effective use or operation.

### 10.4 APPEARANCE

An appearance test should be conducted by human sight at approximately 30 cm distance from the LCD module under fluorescent light. The inspection area of LCD panel shall be within the range of following limits.

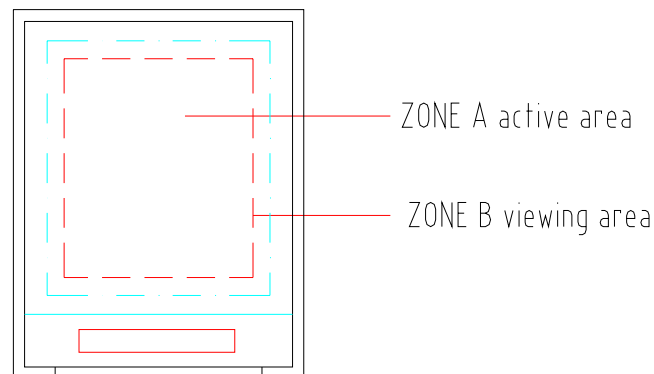

## 10.5 INSPECTION QUALITY CRITERIA

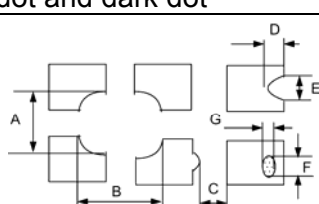
No.	Item	Criterion for defects	Defect type															
1	Non display	No non display is allowed	Major															
2	Irregular operation	No irregular operation is allowed	Major															
3	Short	No short are allowed	Major															
4	Open	Any segments or common patterns that don't activate are rejectable.	Major															
5	Black/White spot	<table border="1" style="width: 100%; border-collapse: collapse;"> <thead> <tr> <th style="text-align: center;">Size D (mm)</th> <th style="text-align: center;">Acceptable number</th> </tr> </thead> <tbody> <tr> <td style="text-align: center;"><math>D \leq 0.15</math></td> <td style="text-align: center;">Ignore</td> </tr> <tr> <td style="text-align: center;"><math>0.15 &lt; D \leq 0.20</math></td> <td style="text-align: center;">3</td> </tr> <tr> <td style="text-align: center;"><math>0.20 &lt; D \leq 0.30</math></td> <td style="text-align: center;">2</td> </tr> <tr> <td style="text-align: center;"><math>0.30 &lt; D</math></td> <td style="text-align: center;">0</td> </tr> </tbody> </table>	Size D (mm)	Acceptable number	$D \leq 0.15$	Ignore	$0.15 < D \leq 0.20$	3	$0.20 < D \leq 0.30$	2	$0.30 < D$	0	Minor					
Size D (mm)	Acceptable number																	
$D \leq 0.15$	Ignore																	
$0.15 < D \leq 0.20$	3																	
$0.20 < D \leq 0.30$	2																	
$0.30 < D$	0																	
6	Black/White line	<table border="1" style="width: 100%; border-collapse: collapse;"> <thead> <tr> <th style="text-align: center;">Length(mm)</th> <th style="text-align: center;">Width (mm)</th> <th style="text-align: center;">Acceptable number</th> </tr> </thead> <tbody> <tr> <td style="text-align: center;"><math>10 &lt; L</math></td> <td style="text-align: center;"><math>0.03 &lt; W \leq 0.04</math></td> <td style="text-align: center;">5</td> </tr> <tr> <td style="text-align: center;"><math>5.0 &lt; L \leq 10</math></td> <td style="text-align: center;"><math>0.04 &lt; W \leq 0.06</math></td> <td style="text-align: center;">3</td> </tr> <tr> <td style="text-align: center;"><math>1.0 &lt; L \leq 5.0</math></td> <td style="text-align: center;"><math>0.06 &lt; W \leq 0.07</math></td> <td style="text-align: center;">2</td> </tr> <tr> <td style="text-align: center;"><math>L \leq 1.0</math></td> <td style="text-align: center;"><math>0.07 &lt; W \leq 0.09</math></td> <td style="text-align: center;">1</td> </tr> </tbody> </table>	Length(mm)	Width (mm)	Acceptable number	$10 < L$	$0.03 < W \leq 0.04$	5	$5.0 < L \leq 10$	$0.04 < W \leq 0.06$	3	$1.0 < L \leq 5.0$	$0.06 < W \leq 0.07$	2	$L \leq 1.0$	$0.07 < W \leq 0.09$	1	Minor
Length(mm)	Width (mm)	Acceptable number																
$10 < L$	$0.03 < W \leq 0.04$	5																
$5.0 < L \leq 10$	$0.04 < W \leq 0.06$	3																
$1.0 < L \leq 5.0$	$0.06 < W \leq 0.07$	2																
$L \leq 1.0$	$0.07 < W \leq 0.09$	1																
7	Back Light	1. No Lighting is rejectable 2. Flickering and abnormal lighting are rejectable	Major															
8	dot defect	<table border="1" style="width: 100%; border-collapse: collapse;"> <tbody> <tr> <td style="text-align: center;">Bright dot</td> <td style="text-align: center;"><math>N \leq 1</math></td> </tr> <tr> <td style="text-align: center;">Dark dot</td> <td style="text-align: center;"><math>N \leq 3</math></td> </tr> <tr> <td style="text-align: center;">Total dot defect (Bright dot + Dark dot)</td> <td style="text-align: center;"><math>N \leq 3</math></td> </tr> <tr> <td style="text-align: center;">Minimum distance between dark dot and dark dot</td> <td style="text-align: center;"><math>L \geq 5 \text{ mm}</math></td> </tr> </tbody> </table>	Bright dot	$N \leq 1$	Dark dot	$N \leq 3$	Total dot defect (Bright dot + Dark dot)	$N \leq 3$	Minimum distance between dark dot and dark dot	$L \geq 5 \text{ mm}$	Minor							
Bright dot	$N \leq 1$																	
Dark dot	$N \leq 3$																	
Total dot defect (Bright dot + Dark dot)	$N \leq 3$																	
Minimum distance between dark dot and dark dot	$L \geq 5 \text{ mm}$																	
9	Display pattern	<div style="text-align: center;">  <p style="text-align: center;">Unit:mm</p> <table border="1" style="width: 100%; border-collapse: collapse;"> <tbody> <tr> <td style="text-align: center;"><math>\frac{A+B}{2} \leq 0.30</math></td> <td style="text-align: center;"><math>0 &lt; C</math></td> <td style="text-align: center;"><math>\frac{D+E}{2} \leq 0.25</math></td> <td style="text-align: center;"><math>\frac{F+G}{2} \leq 0.25</math></td> </tr> </tbody> </table> <p style="text-align: center;">Note: 1. Acceptable up to 3 damages 2. NG if there're two or more pinholes per dot</p> </div>	$\frac{A+B}{2} \leq 0.30$	$0 < C$	$\frac{D+E}{2} \leq 0.25$	$\frac{F+G}{2} \leq 0.25$	Minor											
$\frac{A+B}{2} \leq 0.30$	$0 < C$	$\frac{D+E}{2} \leq 0.25$	$\frac{F+G}{2} \leq 0.25$															

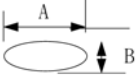
10	Blemish & Foreign matters  Size: $D = \frac{A+B}{2}$	Size D (mm)		Acceptable number	Minor
		$D \leq 0.15$		Ignore	
		$0.15 < D \leq 0.20$		3	
		$0.20 < D \leq 0.30$		2	
		$0.30 < D$		0	
11	Scratch on Polarizer  	Width (mm)	Length (mm)	Acceptable number	Minor
		$W \leq 0.03$	Ignore	Ignore	
		$0.03 < W \leq 0.05$	$L \leq 2.0$	Ignore	
			$L > 2.0$	1	
		$0.05 < W \leq 0.08$	$L > 1.0$	1	
			$L \leq 1.0$	Ignore	
		$0.08 < W$	Note (1)	Note(1)	
		Note(1) Regard as a blemish			
12	Bubble in polarizer	Size D (mm)		Acceptable number	Minor
		$D \leq 0.20$		Ignore	
		$0.20 < D \leq 0.50$		3	
		$0.50 < D \leq 0.80$		2	
		$0.80 < D$		0	
13	Stains on LCD panel surface	Stains that cannot be removed even when wiped lightly with a soft cloth or similar cleaning too are rejectable.			Minor
14	Rust in Bezel	Rust which is visible in the bezel is rejectable.			Minor
15	Defect of land surface contact (poor soldering)	Evident crevices which is visible are rejectable.			Minor
16	Parts mounting	1. Failure to mount parts 2. Parts not in the specifications are mounted 3. Polarity, for example, is reversed			Major Major Major
17	Parts alignment	1. LSI, IC lead width is more than 50% beyond pad outline.			Minor
		2. Chip component is off center and more than 50% of the leads is off the pad outline.			Minor
18	Conductive foreign matter (Solder ball, Solder chips)	1. $0.45 < \varphi$ , $N \geq 1$			Major
		2. $0.30 < \varphi \leq 0.45$ , $N \geq 1$ $\varphi$ : Average diameter of solder ball (unit: mm)			Minor
		3. $0.50 < L$ , $N \geq 1$ L: Average length of solder chip (unit: mm)			Minor

19	Faulty PCB correction	1. Due to PCB copper foil pattern burnout, the pattern is connected, using a jumper wire for repair; 2 or more places are corrected per PCB.	Minor
		2. Short circuited part is cut, and no resist coating has been performed.	Minor

## 10.6 RELIABILITY

Test Item	Test Conditions	Note
High Temperature Operation	70±3°C , t=96 hrs	
Low Temperature Operation	-20±3°C , t=96 hrs	
High Temperature Storage	80±3°C , t=96 hrs	1,2
Low Temperature Storage	-30±3°C , t=96 hrs	1,2
Humidity Test	40°C , Humidity 90%, 96 hrs	1,2
Thermal Shock Test	-30°C ~ 25°C ~ 80°C 30 min. 5 min. 30 min. ( 1 cycle ) Total 5 cycle	1,2
Vibration Test (Packing)	Sweep frequency : 10~55~10 Hz/1min Amplitude : 0.75mm Test direction : X.Y.Z/3 axis Duration : 30min/each axis	2
Static Electricity	150pF 330 ohm ±8kV, 10times air discharge	

Note 1 : Condensation of water is not permitted on the module.

Note 2 : The module should be inspected after 1 hour storage in normal conditions

(15-35°C , 45-65%RH).

Definitions of life end point :

- Current drain should be smaller than the specific value.
- Function of the module should be maintained.
- Appearance and display quality should not have degraded noticeably.
- Contrast ratio should be greater than 50% of the initial value.

## 11 USE PRECAUTIONS

### 11.1 Handling precautions

- 1) The polarizing plate may break easily so be careful when handling it. Do not touch, press or rub it with a hard-material tool like tweezers.
- 2) Do not touch the polarizing plate surface with bare hands so as not to make it dirty. If the surface or other related part of the polarizing plate is dirty, soak a soft cotton cloth or chamois leather in benzine and wipe off with it. Do not use chemical liquids such as acetone, toluene and isopropyl alcohol. Failure to do so may bring chemical reaction phenomena and deteriorations.
- 3) Remove any spit or water immediately. If it is left for hours, the suffered part may deform or decolorize.
- 4) If the LCD element breaks and any LC stuff leaks, do not suck or lick it. Also if LC stuff is stuck on your skin or clothing, wash thoroughly with soap and water immediately.

### 11.2 Installing precautions

- 1) To prevent breaking by static electricity from the human body and clothing, earth the human body properly using the high resistance and discharge static electricity during the operation. In this case, however, the resistance value should be approx.  $1M\Omega$  and the resistance should be placed near the human body rather than the ground surface. When the indoor space is dry, static electricity may occur easily so be careful. We recommend the indoor space should be kept with humidity of 60% or more. When a soldering iron or other similar tool is used for assembly, be sure to earth it.
- 2) When installing the module and ICs, do not bend or twist them. Failure to do so may crack LC element and cause circuit failure.
- 3) To protect LC element, especially polarizing plate, use a transparent protective plate (e.g., acrylic plate, glass etc) for the product case.
- 4) Do not use an adhesive like a both-side adhesive tape to make LCD surface (polarizing plate) and product case stick together. Failure to do so may cause the polarizing plate to peel off.

### 11.3 Storage precautions

- 1) Avoid a high temperature and humidity area. Keep the temperature between 0°C and 35°C and also the humidity under 60%.
- 2) Choose the dark spaces where the product is not exposed to direct sunlight or fluorescent light.
- 3) Store the products as they are put in the boxes provided from us or in the same conditions as we recommend.

### 11.4 Operating precautions

- 1) Do not boost the applied drive voltage abnormally. Failure to do so may break ICs. When applying power voltage, check the electrical features beforehand and be careful. Always turn off the power to the LC module controller before removing or inserting the LC module input connector. If the input connector is removed or inserted while the power is turned on, the LC module internal circuit may break.
- 2) The display response may be late if the operating temperature is under the normal standard, and the display may be out of order if it is above the normal standard. But this is not a failure; this will be restored if it is within the normal standard.
- 3) The LCD contrast varies depending on the visual angle, ambient temperature, power voltage etc. Obtain the optimum contrast by adjusting the LC drive voltage.
- 4) When carrying out the test, do not take the module out of the low-temperature space suddenly. Failure to do so will cause the module condensing, leading to malfunctions.
- 5) Make certain that each signal noise level is within the standard (L level: 0.2V<sub>dd</sub> or less and H level: 0.8V<sub>dd</sub> or more) even if the module has functioned properly. If it is beyond the standard, the module may often malfunction. In addition, always connect the module when making noise level measurements.
- 6) The CMOS ICs are incorporated in the module and the pull-up and pull-down function is not adopted for the input so avoid putting the input signal open while the power is ON.
- 7) The characteristic of the semiconductor element changes when it is exposed to light emissions, therefore ICs on the LCD may malfunction if they receive light emissions. To prevent these malfunctions, design and assemble ICs so that they are shielded from light emissions.

- 8) Crosstalk occurs because of characteristics of the LCD. In general, crosstalk occurs when the regularized display is maintained. Also, crosstalk is affected by the LC drive voltage. Design the contents of the display, considering crosstalk.

### 11.5 Other

- 1) Do not disassemble or take the LC module into pieces. The LC modules once disassembled or taken into pieces are not the guarantee articles.
- 2) The residual image may exist if the same display pattern is shown for hours. This residual image, however, disappears when another display pattern is shown or the drive is interrupted and left for a while. But this is not a problem on reliability.
- 3) AMIPRE will provide one year warranty for all products and three months warranty for all repairing products.

# 12 Mechanical Dimensions

