



晶采光電科技股份有限公司
AMPIRE CO., LTD.

SPECIFICATIONS FOR LCD MODULE

CUSTOMER	
CUSTOMER PART NO.	
AMPIRE PART NO.	AM-640480G4TNQW-A0H
APPROVED BY	
DATE	

Approved For Specifications

Approved For Specifications & Sample

AMPIRE CO., LTD.

**2F., No.88, Sec. 1, Sintai 5th Rd., Sijhih City, Taipei County 221,
Taiwan (R.O.C.)台北縣汐止市新台五路一段 88 號 2 樓(東方科學園區 D 棟)
TEL:886-2-26967269 , FAX:886-2-26967196 or 26967270**

APPROVED BY	CHECKED BY	ORGANIZED BY

RECORD OF REVISION

Revision Date	Page	Contents	Editor
2010/8/24	--	New Release	Eric
2011/3/23	6	Modify Interface pin define.	Eric
	8	Added TTL input timing	Eric
	12	Modify Incoming Inspection Standard	Eric

1. INTRODUCTION

This is a color active matrix TFT-LCD that uses amorphous silicon TFT as a switching device . This model is composed of a 5.7inch TFT-LCD panel , a driving circuit and LED backlight system . This TFT-LCD has a high resolution (640(R.G.B) X 480) and can display up to 262,144 colors.

1-1. Features

- VGA Resolution
- 6 Bits color driver with LVDS interface
- Wide range operation temperature

2. PHYSICAL SPECIFICATIONS

Item	Specifications	unit
Display resolution(dot)	640RGB (W) x 480(H)	dots
Display area	115.2 (W) x 86.4 (H)	mm
Pixel pitch	0.18 (W) x 0.18 (H)	mm
Color configuration	R.G.B Vertical stripe	
Overall dimension	127.0(W)x98.43(H)x8.3(D)---(Typ)	mm
Surface treatment	Antiglare , Hard-Coating(3H)	
Brightness	500	cd/m ²
Contrast ratio	250 : 1	
Backlight unit	LED	
Display color	262,144	colors
Viewing Direction	12 o'clock	
Display Mode	Normally White	

3. ABSOLUTE MAXIMUM RATINGS

ITEM	SYMBOL	MIN	MAX	UNIT	NOTE
Power Supply Voltage	V _{cc}	-0.5	5	V	
Signal Input Voltage	DCLK, DE R0~R5 G0~G5 B0~B5	-0.5	V _{cc} + 0.5	V	
Operation Temperature	Top	-20	70	°C	
Storage Temperature	Tstg	-30	80	°C	

4. ELECTRICAL CHARACTERISTICS

4-1 TFT LCD Module voltage

ITEM	SYMBOL	MIN	TYP	MAX	UNIT	NOTE
Power Voltage For LCD	V _{CC}	3.0	3.3	3.6	V	
Power Voltage For VLED	V _{DD}	--	5.0	--	V	
Logic Input Voltage	V _{IH}	V _{CC} *0.7	--	V _{CC}	V	
	V _{IL}	0	--	V _{CC} *0.3	V	
ADJ Input Voltage	V _{IH}	3.0	--	5.0	V	
	V _{IL}	GND	--	0.3	V	

4-2 TFT LCD current consumption

ITEM	SYMBOL	MIN	TYP	MAX	UNIT	NOTE
LCD Power Current	I _{CC}	-	106	-	mA	(1)
LED Power Current	I _{LED} (VLED=5V)	-	290	-	mA	

NOTE : (1) Typ : under 64 gray pattern Max : under black pattern



(a) 64 Gray Pattern

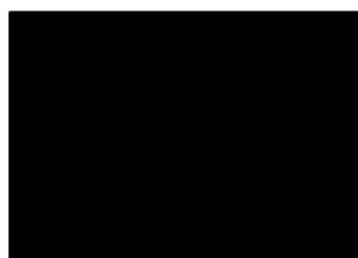

(b) Black Pattern

6. INTERFACE

LVDS CN1:

Pin no	Symbol	Function
1	VDD	POWER SUPPLY:3.3V
2	VDD	POWER SUPPLY:3.3V
3	Gnd	Power Ground
4	Gnd	Power Ground
5	IN0-	Transmission Data of Pixels
6	IN0+	Transmission Data of Pixels
7	Gnd	Power Ground
8	IN1-	Transmission Data of Pixels 1
9	IN1+	Transmission Data of Pixels 1
10	Gnd	Power Ground
11	IN2-	Transmission Data of Pixels 2
12	IN2+	Transmission Data of Pixels 2
13	Gnd	Power Ground
14	CLK-	Sampling Clock
15	CLK+	Sampling Clock
16	Gnd	Power Ground
17	VLED	Power Supply for LED Backlight : 5V
18	VLED	Power Supply for LED Backlight : 5V
19	Gnd	Power Ground
20	ADJ	LED backlight adjustment

NOTE :

- ADJ adjust brightness to control Pin , Pulse duty the bigger the brighter.

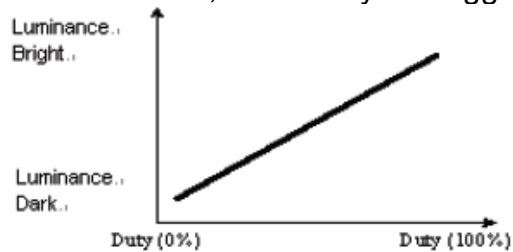

- ADJ signal = 0 ~ 5.0V , operation frequency : 100Hz~200KHz

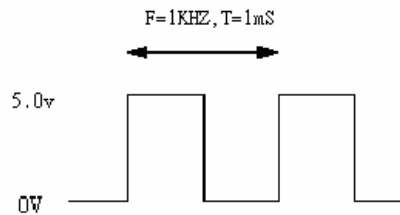

- VSS Pin must ground contact , can not be floating.

7. AC Timing characteristic of the LVDS

7.1 Timing Parameter

Switching Characteristics

over recommended operating conditions (unless otherwise noted)

PARAMETER		TEST CONDITIONS	MIN	TYP ⁽¹⁾	MAX	UNIT
t_{su}	Setup time, D0–D20 to CLKOUT↓	$C_L = 8 \text{ pF}$, See Figure 5	5			ns
t_h	Data hold time, CLKOUT↓ to D0–D20		5			ns
$t_{(RSKM)}$	Receiver input skew margin ⁽²⁾ (see Figure 7)	$t_c = 15.38 \text{ ns}$ ($\pm 0.2\%$), Input clock jitter < 50 ps, ⁽³⁾	550	700		ps
t_d	Delay time, CLKIN↑ to CLKOUT↓ (see Figure 7)	$V_{CC} = 3.3 \text{ V}$, $t_c = 15.38 \text{ ns}$ ($\pm 0.2\%$), $T_A = 25^\circ\text{C}$	3	5	7	ns
t_{en}	Enable time, SHTDN to phase lock	See Figure 7		1		ms
t_{dis}	Disable time, SHTDN to off state	See Figure 8		400		ns
t_t	Transition time, output (10% to 90% t_r or t_f) (data only)	$C_L = 8 \text{ pF}$		3		ns
t_t	Transition time, output (10% to 90% t_r or t_f) (clock only)	$C_L = 8 \text{ pF}$		1.5		ns
t_w	Pulse duration, output clock			$0.50 t_c$		ns

(1) All typical values are at $V_{CC} = 3.3 \text{ V}$, $T_A = 25^\circ\text{C}$.

(2) The parameter $t_{(RSKM)}$ is the timing margin available to allocate to the transmitter and interconnection skews and clock jitter. The value of this parameter at clock periods other than 15.38 ns can be calculated from $t_{RSKM} = t_c/14 - 550 \text{ ps}$.

(3) |Input clock jitter| is the magnitude of the change in input clock period.

PARAMETER MEASUREMENT INFORMATION (continued)

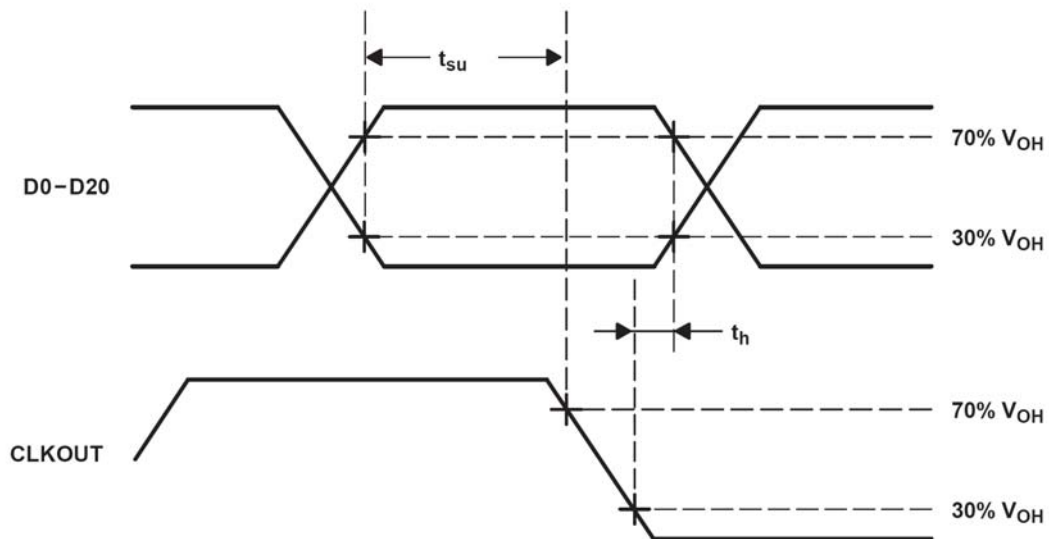

Figure 5. Setup and Hold Time Waveforms

PARAMETER MEASUREMENT INFORMATION (continued)

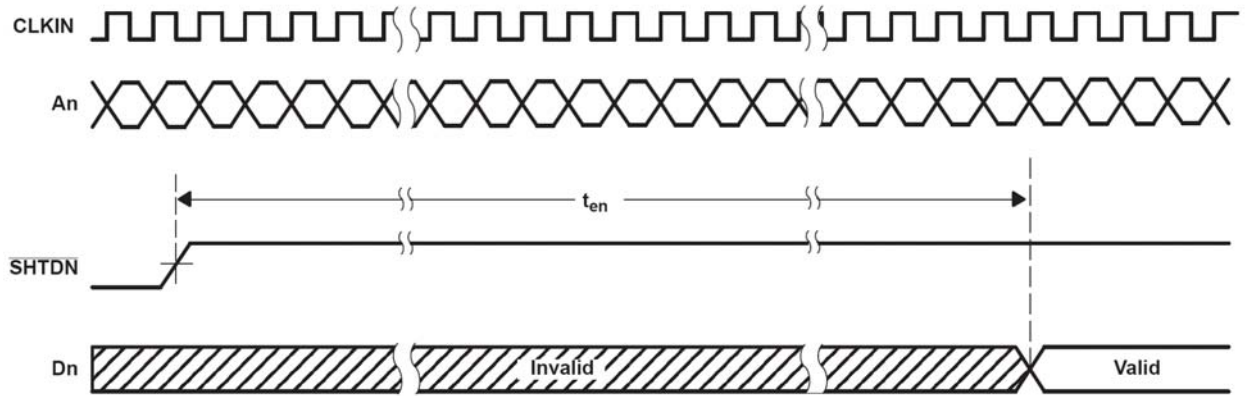

Figure 7. Enable Time Waveforms

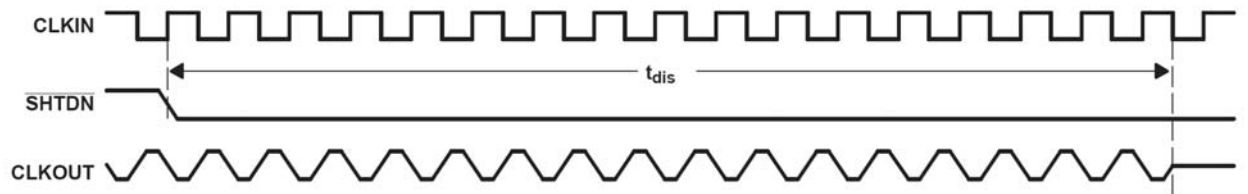

Figure 8. Disable Time Waveforms

7.2 Recommended Input Timing of LVDS transmitter

PARAMETER	Symbol	Min.	Typ.	Max	Unit
CLK frequency	F_{CPH}		25.175		MHz
CLK period	T_{CPH}	-	39.7	-	ns
CLK pulse duty	T_{CWH}	40	50	60	%
HS period	T_H	-	800	-	T_{CPH}
HS pulse width	T_{WH}	5	30	-	T_{CPH}
HS-first horizontal data time	T_{HS}	112	144	175	T_{CPH}
DEN pulse width	T_{EP}	-	640	-	T_{CPH}
VS pulse width	T_{WV}	1	3	5	T_H
VS-DEN time	T_{STV}	-	35	-	T_H
VS period	T_V	-	525	-	T_H

Note: When SYNC mode is used, 1st data start from 144th CLK after HS falling (when $STHD[5:0]=00000$)

PARAMETER	Symbol	Min.	Typ.	Max	Unit
OEV pulse width	T_{OEV}		100	-	T_{CPH}
CKV pulse width	T_{CKV}	-	96	-	T_{CPH}
HS-CKV time	T_1	-	52	-	T_{CPH}
HS-OEV time	T_2	-	8	-	T_{CPH}
HS-POL time	T_3	-	72	-	T_{CPH}
STV setup time	T_{SUV}	-	46	-	T_{CPH}
STV pulse width	T_{WSTV}	-	1	-	T_H

Clock and Data input waveforms

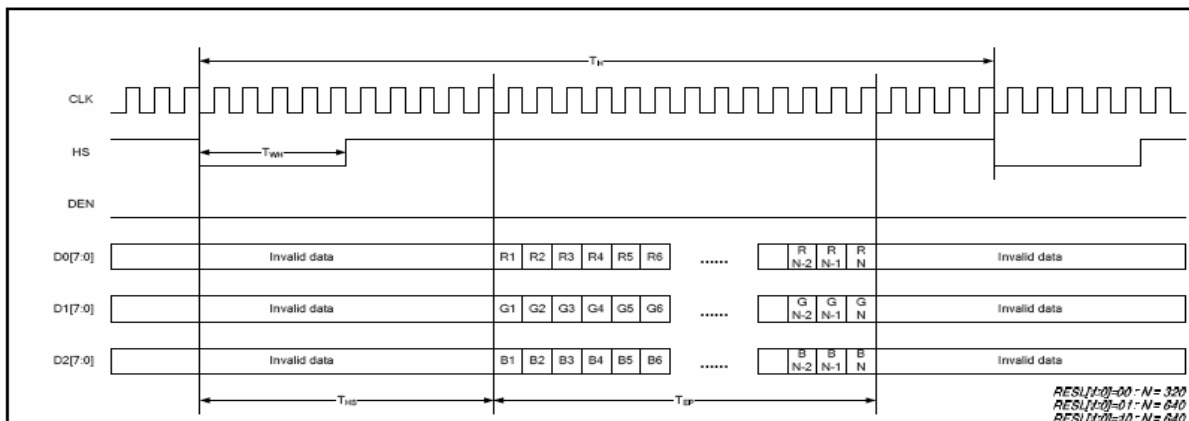
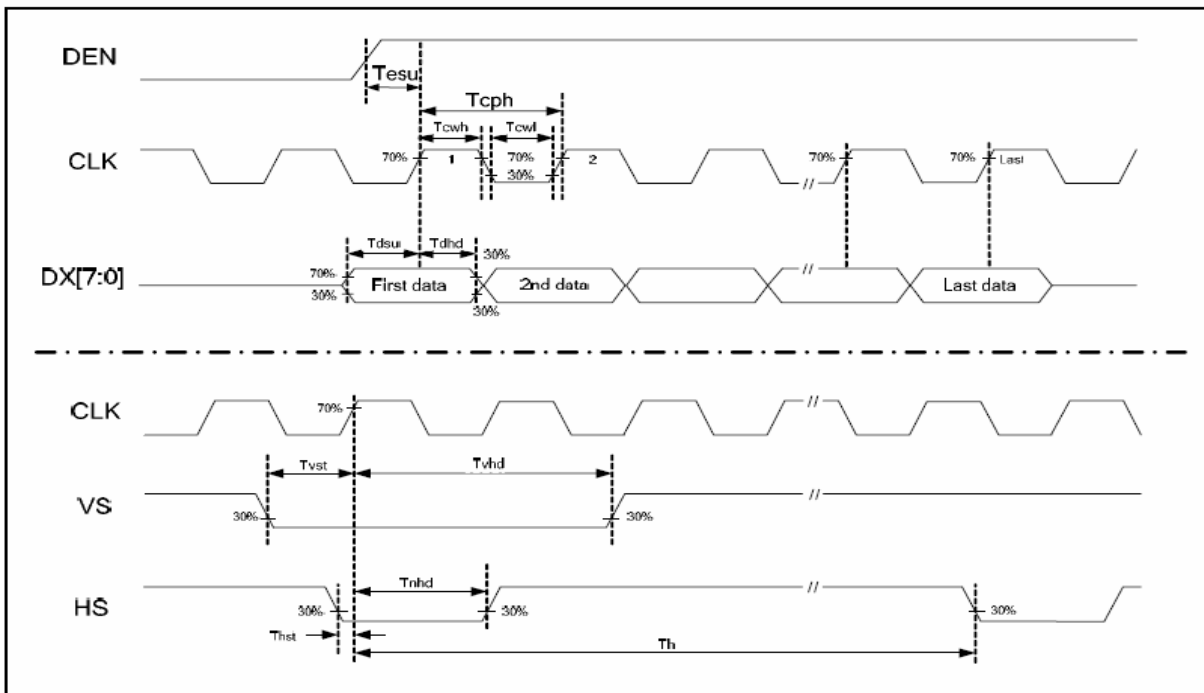

Parallel RGB SYNC Mode Horizontal Data Format

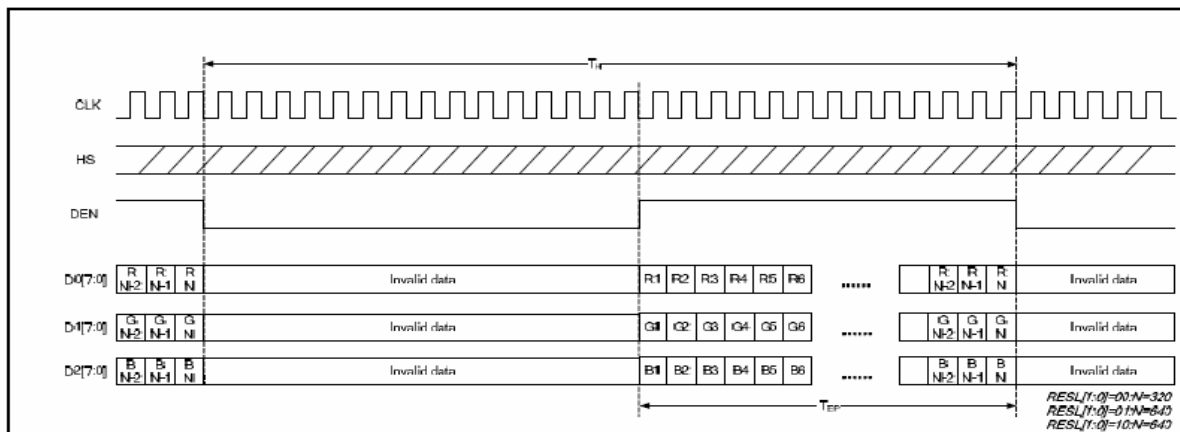

Parallel RGB DE Mode Horizontal Data Format

8. OPTICAL CHARACTERISTICS

Item	Symbol	Condition	Min.	Typ.	Max.	Unit	Note	
Contrast ratio	CR	Point - 5 $\Theta = \Phi = 0^\circ$	200	250	--	--	(1)(2)(3)	
Luminance	Lw		350	500	-	cd/m ²	(1)(3)	
Luminance Uniformity	ΔL		70	75	-	%	(1)(3)	
Response Time (White – Black)	$T_r + T_f$		--	50	--	ms	(1)(3)(5)	
Viewing Angle	Vertical	Θ	CR \geq 10 Point – 5	80	100	-	Deg.	(1)(2)(4)
	Horizontal	Φ		120	140	-		
Color chromaticity	Red	Rx	Point - 5 $\Theta = \Phi = 0^\circ$	0.566	0.616	0.666	--	(1)(3)
		Ry		0.302	0.352	0.402		
	Green	Gx		0.308	0.358	0.408		
		Gy		0.518	0.568	0.618		
	Blue	Bx		0.096	0.146	0.196		
		By		0.086	0.136	0.186		
	White	Wx		0.296	0.346	0.396		
		Wy		0.328	0.378	0.428		
LED life time		Ta = 25°C		20K		hour	(1)(6)	

NOTE :

- (1) Measure conditions : 25°C±2°C , 60±10%RH under 10Lux , in the dark room by BM-7TOPCON), viewing 2° , VCC=3.3V , VDD=3.3V

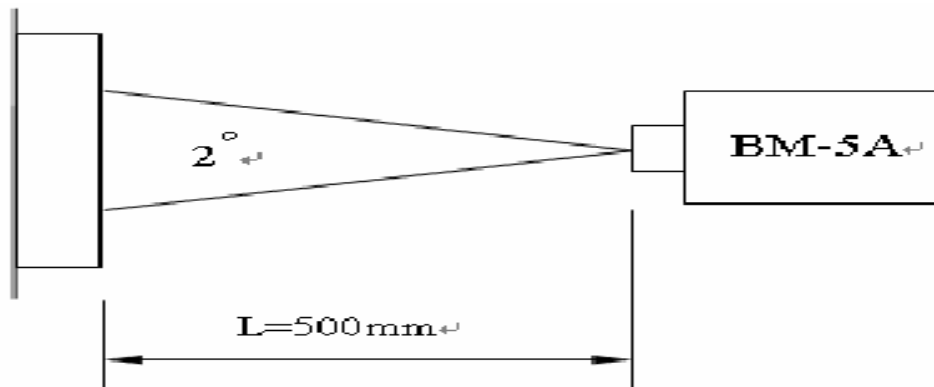

- (2) Definition of Contrast Ratio :

$$\text{Contrast Ratio (CR)} = (\text{White}) \text{ Luminance of ON} \div (\text{Black}) \text{ Luminance of OFF}$$

- (3) Definition of Luminance :

Definition of Luminance Uniformity

Measure white luminance on the point 5 as figure9-1

Measure white luminance on the point 1 ~ 9 as figure9-1

$$\Delta L = [L(\text{MIN}) / L(\text{MAX})] \times 100\%$$

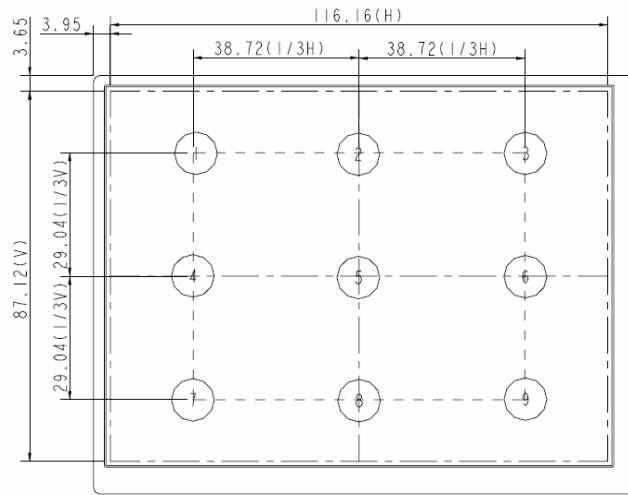

Fig9-1 Measuring point

(4) Definition of Viewing Angle(Θ, Φ), refer to Fig9-2 as below :

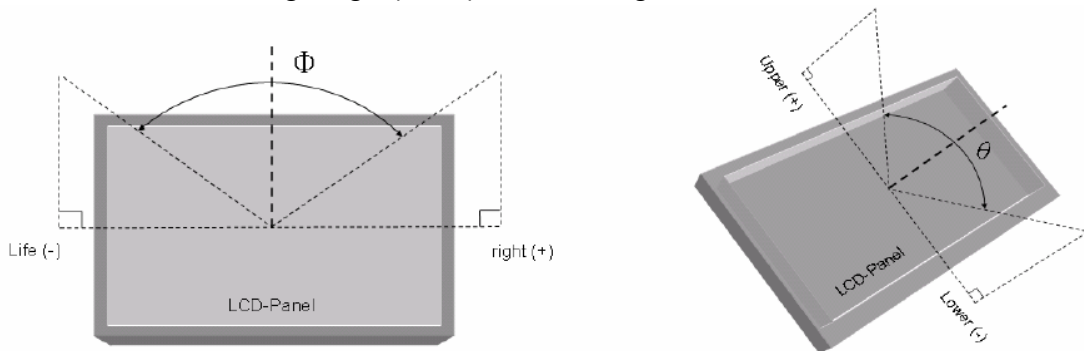

Fig9-2 Definition of Viewing Angle

(5) Definition of Response Time.(White – Black)

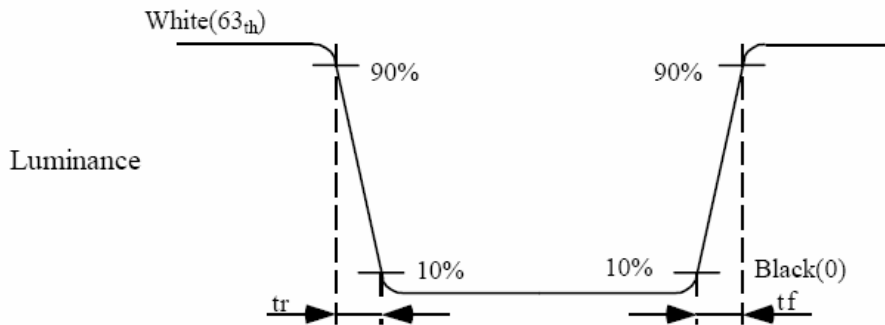

Fig9-3 Definition of Response Time(White-Black)

(6) End of Life shall be determined by the time when any of the following is satisfied under continuous lighting at 25°C .

- Intensity drops to 50% of the Initial Value (Min. Luminance)
- Based on LED
- It is an estimative value

9. INCOMING INSPECTION STANDARD FOR TFT-LCD PANEL

Defect Type			Limit		Note
Visual Defect	Internal	Spot	$\phi < 0.2\text{mm}$	Ignore	(1)
			$0.2\text{mm} \leq \phi \leq 0.4\text{mm}$	$N \leq 3$	
			$0.4\text{mm} < \phi$	$N=0$	
		Fiber	$W \leq 0.05\text{mm}$	Ignore	(1)
			$0.05\text{mm} < W \leq 0.1\text{mm}, L \leq 4\text{mm}$	$N \leq 3$	
			$0.1\text{mm} < W, 4\text{mm} < L$	$N=0$	
	Polarizer Bubble	$\phi < 0.15\text{mm}$	Ignore	(1)	
		$0.15\text{mm} \leq \phi \leq 0.5\text{mm}$	$N \leq 4$		
		$0.5\text{mm} < \phi$	$N=0$		
	Mura	It' OK if mura is slight visible through 6%ND filter			
Electrical Defect	Bright Dot		$N \leq 2$		(2)
	Dark Dot		$N \leq 3$		
	Total Dot		$N \leq 4$		
	Two Adjacent Dot		$N \leq 1$ pair		(3)
	Three or More Adjacent Dot		Not Allowed		
	Line Defect		Not Allowed		

(1) One pixel consists of 3 sub-pixels, including R,G, and B dot.(Sub-pixel = Dot)

(2) LITTLE BRIGHT DOT ACCEPTITABLE UNDER 6 % ND-Filter

[Note1] W : Width[mm], L : Length[mm], N : Number, ϕ : Average Diameter

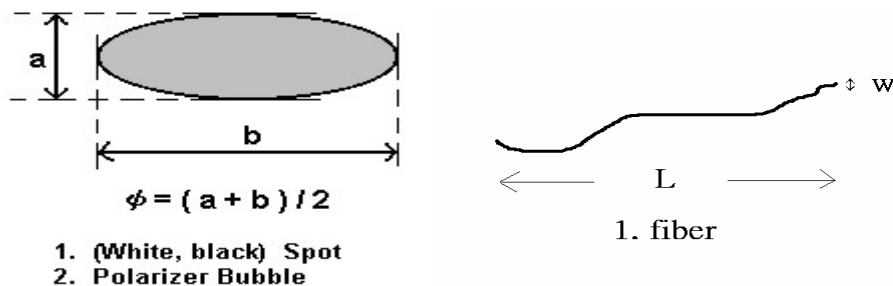

[Note2] Bright dot is defined through 6% transmission ND Filter as following.

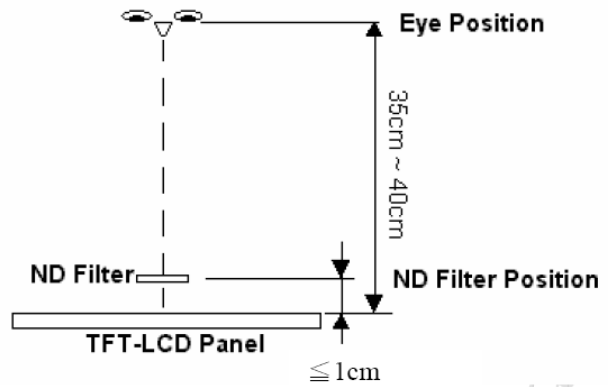
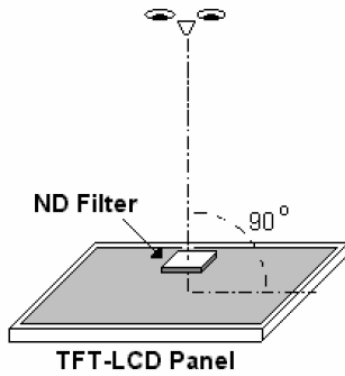

[Note3]

Judge defect dot and adjacent dot as following. Allow below (as A, B, C and D status) adjacent defect dots, including bright and dark adjacent dot. And they will be counted 2 defect dots in total quantity.

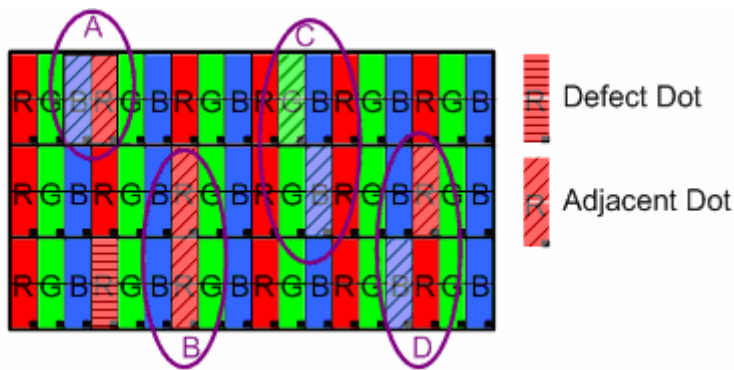

- (1) The defects that are not defined above and considered to be problem shall be reviewed and discussed by both parties.
- (2) Defects on the Black Matrix, out of Display area, are not considered as a defect or counted.

10. RELIABILITY TEST CONDITIONS

ITEM	CONDITIONS
HIGH TEMPERATURE OPERATION	70°C , 240Hrs
HIGH TEMPERATURE AND HIGH HUMIDITY OPERATION	60°C , 90%RH , 240Hrs
HIGH TEMPERATURE STORAGE	80°C , 240Hrs
LOW TEMPERATURE OPERATION	-20°C , 240Hrs
LOW TEMPERATURE STORAGE	-30°C , 240Hrs
THERMAL SHOCK	-30°C (0.5Hr) ~80°C (0.5Hr) 200Cycle

10.1 OTHERS

AMIPRE will provide one year warranty for all products and three months warrantee for all repairing products.

11. OUTLINE DIMENSION

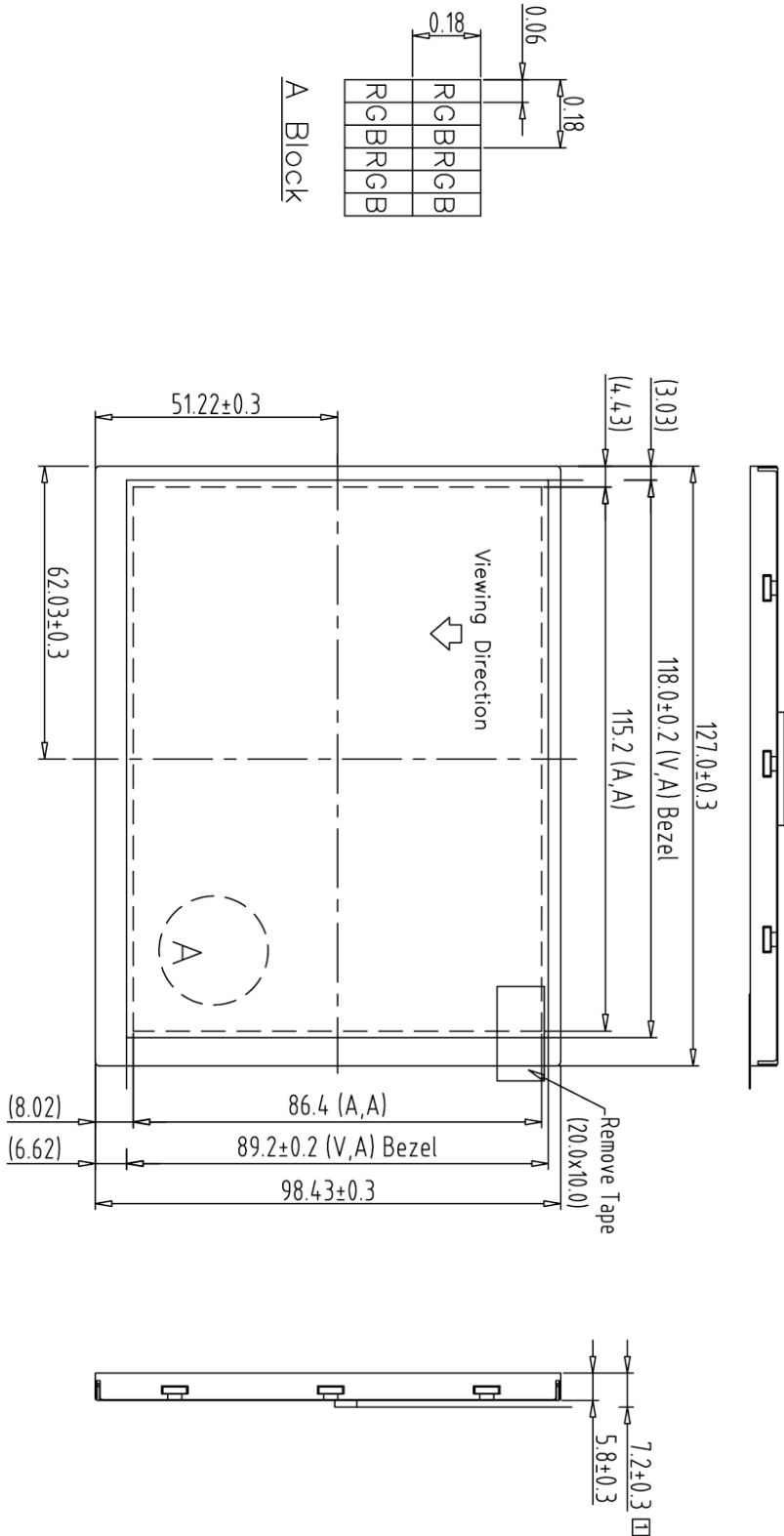

- Note:
1. Unless indicated, Tolerance Grade "B" is adopted.
 2. UV Glue For OLB Protection.
 3. LCD 640x480 (R,G,B) TFT LCD=>640480G2 5.7" VGA TFT LCD

1	TFT640480-63-0	TOLERANCE GRADE(F)	A	B	DIAM.	MM	DW'N.	SNOW	DATE	TITLE
2		~6	0.05	0.1					08-20-10'	晶采光电科技
3		6~18	0.08	0.18	JE NO.		CHK.		DATE	640480G4-A0
4		18~50	0.1	0.25						LVDS (5.7")
5		50~180	0.2	0.4	PARTS NO. LCM		APPD.		DATE	
6		180~	0.3	0.5	640480G4-A0					DWG. NO. *100849MA
										SHEET 1 OF 1

REV	REVISION RECORD	DATE	NAME
0	NEW RELEASE	06-20-10'	SNOW
1	Revise TFT640480-63-1 to 640480G4-A0 & Modify DFMA-70P-125H to DFPA-6-20P-1H5G1 [0-29-10] SNOW		

REV	REVISION RECORD	DATE	NAME
0	NEW RELEASE	08-20-10	SNOW
1	Revise TFT640480-63-9 to 640480G4-A0 & Modify DF14A-20P-125H to DF19-G-20P-1H(56)	10-29-10	SNOW

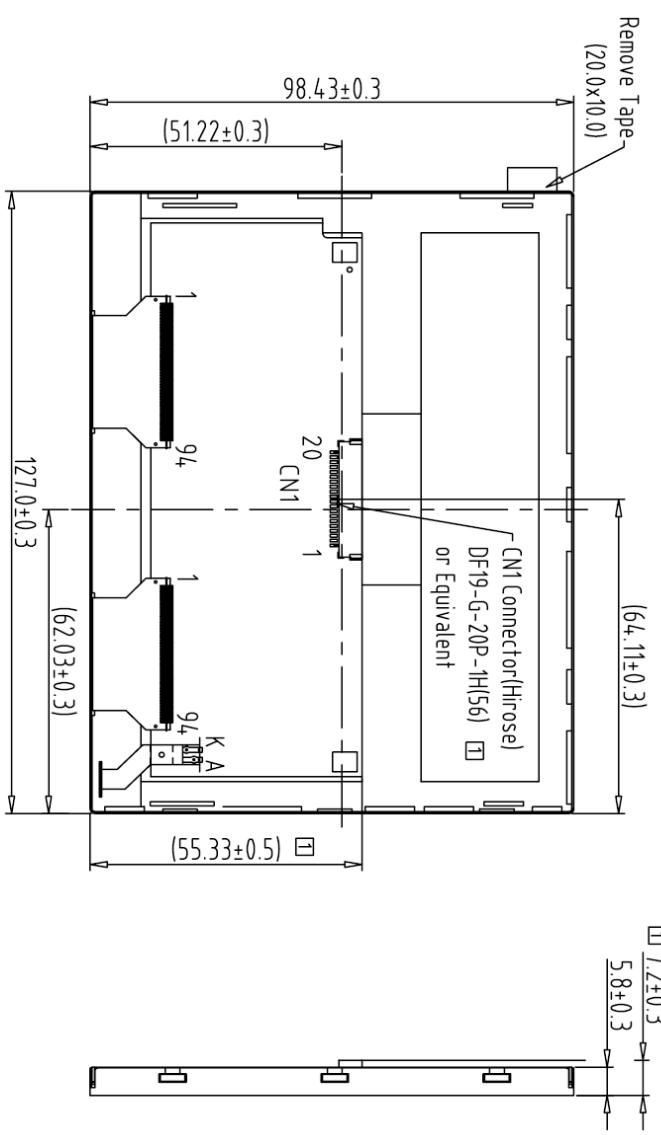

Back view

- Note:
1. Unless indicated, Tolerance Grade "B" is adopted.
 2. UV Glue For OLB Protection.
 3. LCD 640x480 (R.G.B) TFT LCD=>640480G2 5.7" VGA TFT LCD

1	TFT640480-63-0	7		TOLERANCE GRADE(F)	A	B	DIM.	MM	DWN.	SNOW	DATE	TITLE	DWG. NO.	SHEET
2		8		~6	0.05	0.1					08-20-10	640480G4-A0	*1008SOMA	1 OF 1
3		9		6~18	0.08	0.18	IE NO.		CHK.		DATE	晶光电科技		
4		10		18~50	0.1	0.25						LVDS (5.7")		
5		11		50~180	0.2	0.4	PARTS NO.	LCM-1	APPD.		DATE			
6		12		180~	0.3	0.5	640480G4-A0							