



## SPECIFICATIONS FOR LCD MODULE

<b>CUSTOMER</b>	
<b>CUSTOMER PART NO.</b>	
<b>AMPIRE PART NO.</b>	<b>AM- 800480FTMQW-00H</b>
<b>APPROVED BY</b>	
<b>DATE</b>	

- Preliminary Specification
- Approved Specification

**AMPIRE CO., LTD.**

**TOWER A, 4F, No.114, Sec. 1, HSIN-TAI 5th RD., HIS-CHIH,  
TAIPEI HSIEN, TAIWAN(R.O.C.)**

**台北縣汐止鎮新台五路一段114號4樓(東方科學園區A棟)**

**TEL:886-2-26967269, FAX:886-2-26967196 or 886-2-26967270**

<b>APPROVED BY</b>	<b>CHECKED BY</b>	<b>ORGANIZED BY</b>

## RECORD OF REVISION

Revision Date	Page	Contents	Editor
2007/6/4	-	New Release	Edward

## 1. Features

10.2 inch Amorphous-TFT-LCD (Thin Film Transistor Liquid Crystal Display) module. This module is composed of a 10.2" TFT-LCD panel and backlight unit.

- (1) Construction: 10.2" a-Si color TFT-LCD, White LED Backlight .
  - (2) Resolution (pixel): 800(R.G.B) X480
  - (3) Number of the Colors : 262K colors ( R , G , B 6 bit digital each)
  - (4) LCD type : Transmissive Color TFT LCD ( normally White)
  - (5) Interface: 60 pin
  - (6) Power Supply Voltage: 3.3V single power input.
- Viewing Direction: 6 O'clock ( The direction it's hard to be discolored )

## 2. PHYSICAL SPECIFICATIONS

Item	Specifications	unit
LCD size	10.2 inch (Diagonal)	
Resolution	800 x 3(RGB) x 480	dot
Dot pitch	0.0925(W) x 0.276(H)	mm
Active area	222.0(W) x 132.48(H)	mm
Module size	235.0(W) x 145.8(H) x 6.1(D)	mm
Surface treatment	Anti-Glare	
Color arrangement	RGB-stripe	
interface	Digital	
Backlight power consumption	2.57 (Typ.)	W
Panel power consumption	250 (Typ.)	mW
Weight	335.2	g

### 3. ABSOLUTE MAX. RATINGS

(GND = AVSS = 0V, Note 2)

Item	Symbol	Values		UNIT	Note
		Min.	Max.		
Power voltage	VCC	-0.3	5	V	
	AVDD	-0.5	12		
	VGH	-0.3	18		
	VGL	-15	0.3		
	VGH-VGL	--	33		
Input signal voltage	V1~V7	0.4AVDD	AVDD-0.1	V	Note 1
	V8~V14	-0.3	0.6AVDD	V	
Operation temperature	TOP	-30	85	°C	
Storage temperature	TST	-30	85	°C	

Note 1:  $AVDD - 0.1 \geq V1 \geq V2 \geq V3 \geq V4 \geq V5 \geq V6 \geq V7 \geq V8 \geq V9 \geq V10 \geq V11 \geq V12 \geq V13 \geq V14 \geq AVSS + 0.1$

Note 2: The absolute maximum rating values of the module should not be exceeded. Once exceeded absolute maximum rating values, the characteristics of the module may not be recovered. Even in an extreme condition, may result in module permanently destroyed.

## 4. ELECTRICAL CHARACTERISTICS

### 4-1 Typical Operation Conditions

(GND = AVSS = 0V, Note 1)

Item	Symbol	Values			UNIT	Note
		Min.	Typ.	Max.		
Power voltage	VCC	3.0	3.3	3.6	V	
	AVDD	9.0	9.2	9.4		
	VGH	14.3	15	15.7		
	VGL	-10.5	-10	-9.5		
Input signal voltage	VCOM	3.5	3.7	3.9	V	$(V1+V14)/2=4.5V$
	V1~V7	0.4 AVDD	--	AVDD-0.1		
	V8~V14	0.1	--	0.6 AVDD		
Input logic high voltage	VIH	0.7VCC	--	VCC	V	
Input logic low voltage	VIL	0	--	0.3 VCC	V	

Note 1 : Be sure to apply GND, VCC, and VGL, to the LCD first, and then apply VGH.

### 4-2 Current Consumption

(GND = AVSS = 0V)

Item	Symbol	Values			Unit	Note
		Min.	Typ.	Max.		
Current for Driver	IGH	--	0.3	0.5	mA	VGH = 15V
	IGL	--	0.2	1.0	mA	VGL = -10V
	ICC	--	4	10	mA	VCC = 3.3V
	IDD	--	25	50	mA	AVDD = 9.2V

### 4-3 Backlight Driving Conditions

Item	Symbol	Values			Unit	Note
		Min.	Typ.	Max.		
LED voltage	VL	--	9.9	10.5	V	Note 2
LED current	IL	--	20	--	mA	Note 2、3
LED life time	--	20,000	--	--	Hr	Note1

Note 1 : The "LED life time" is defined as the module brightness decrease to 50% original brightness that ambient temperature is 25°C and IL = 20mA.

Note 2 : The LED driving condition is defined for each LED module. (3 LED Serial)

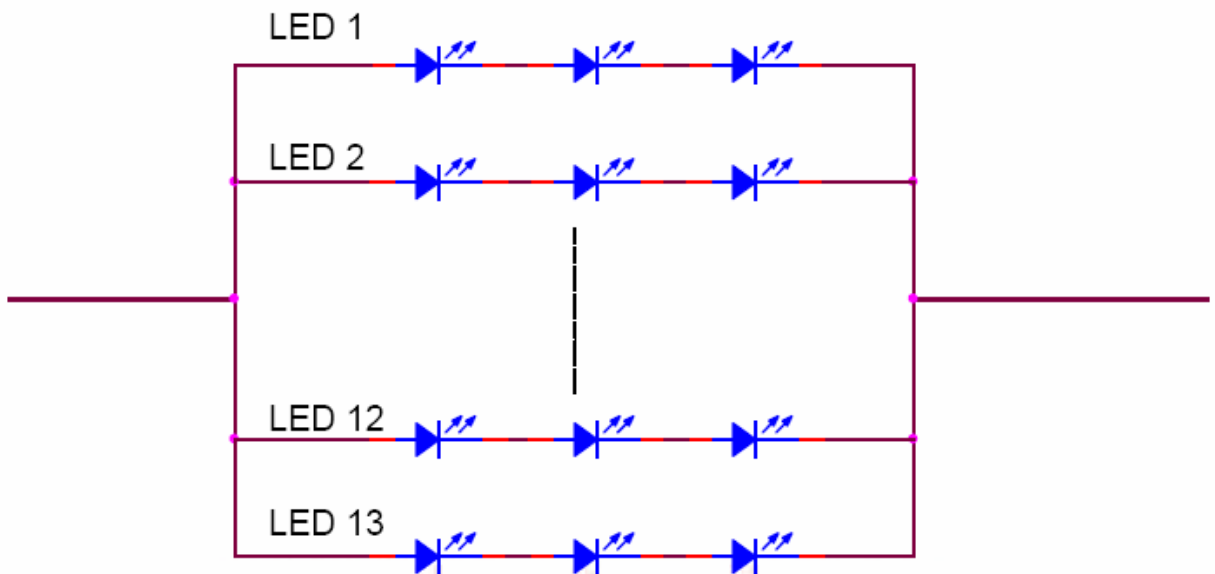

Note 3 : When LCM is operated over 40°C ambient temperature, the ILED of each LED module (3 LED Serial) should be follow :

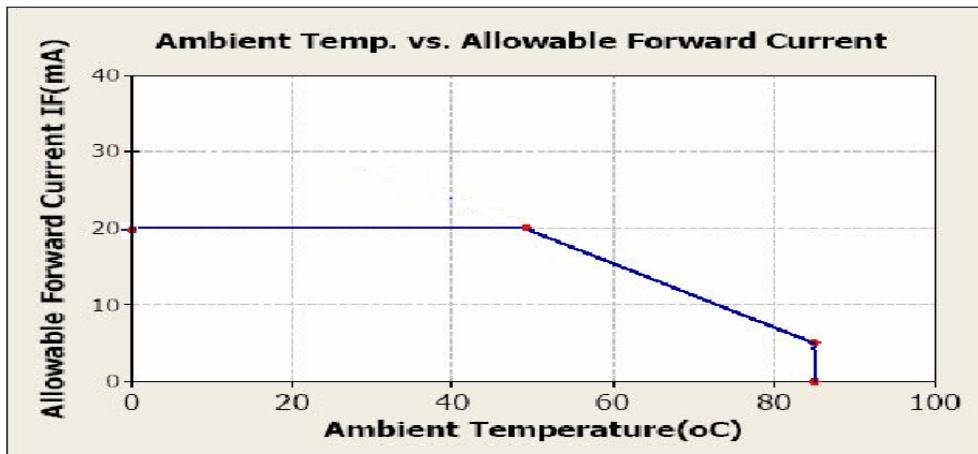

## 4-4 Power Sequence

### 4-4-1 Power on :

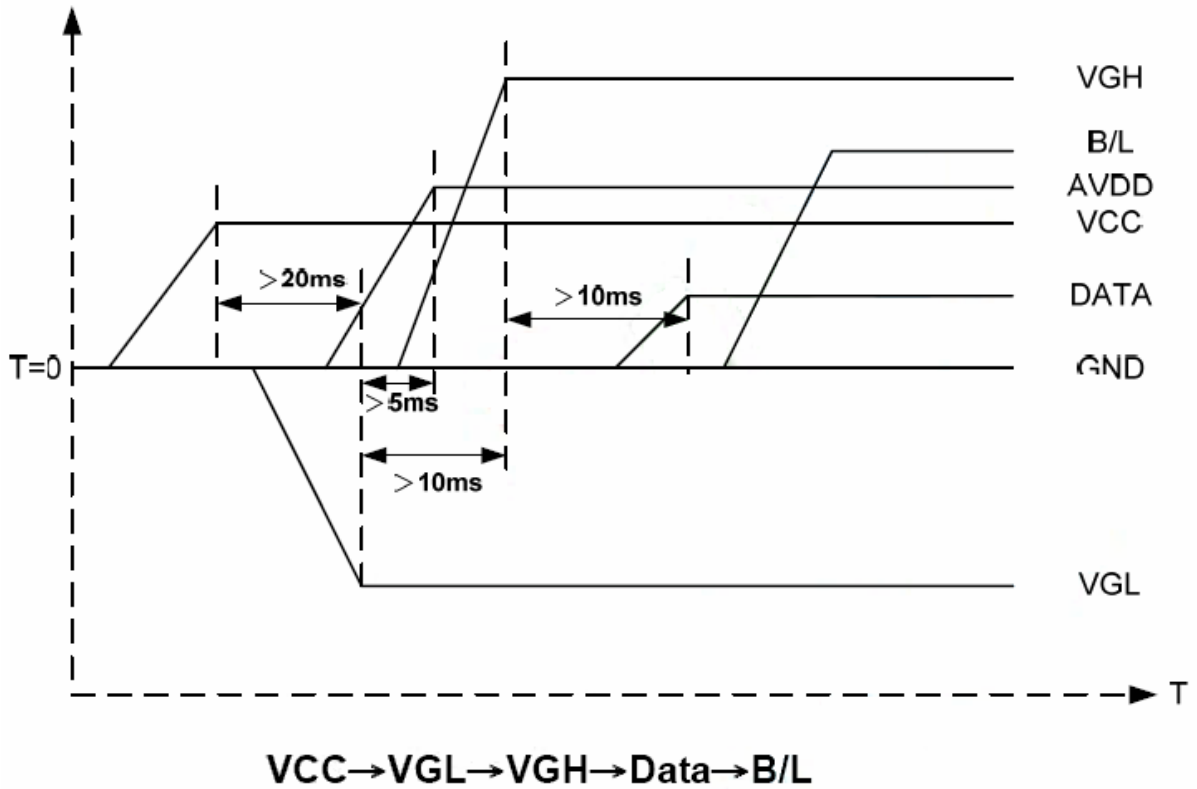

### 4-4-2 Power off :

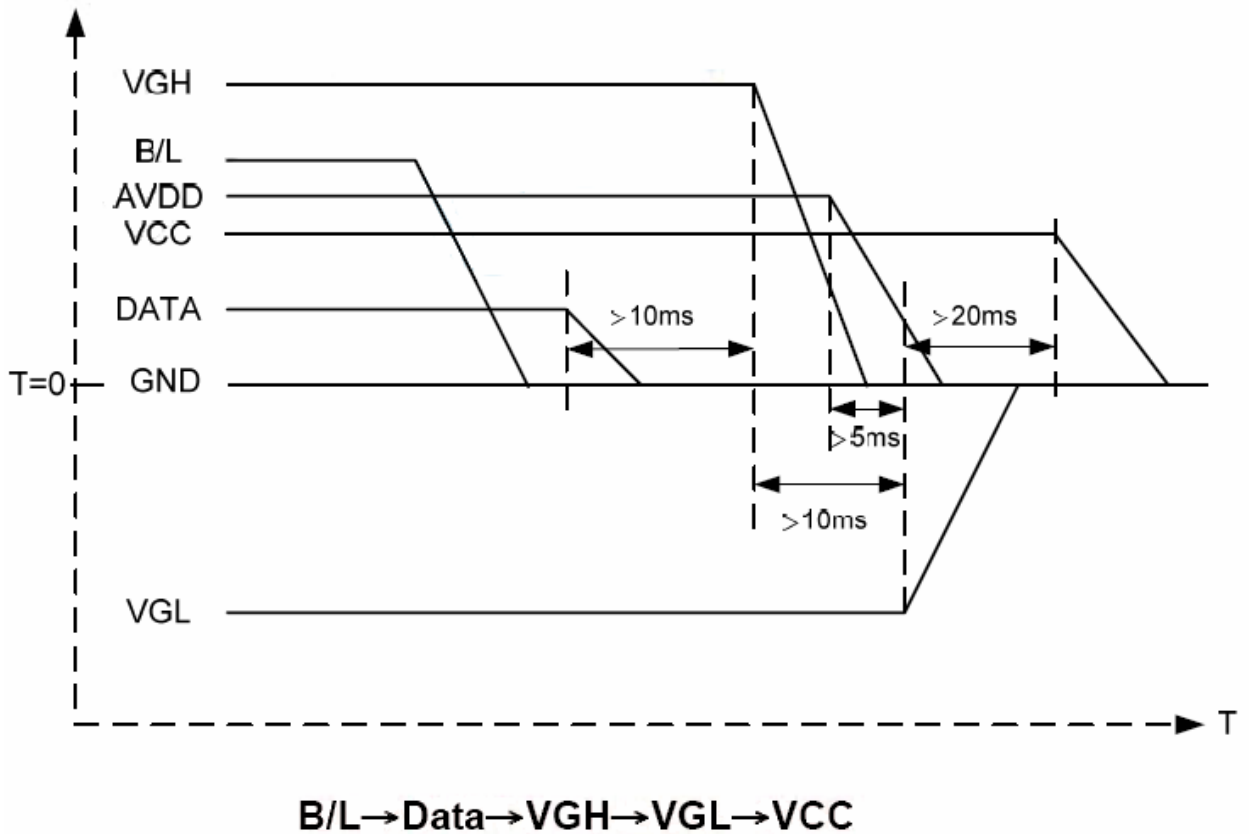

## 5. Optical Specifications

Item	Symbol	Condition	Values			Unit	Note
			Min.	Typ.	Max.		
Viewing angle (CR $\geq$ 10)	$\theta$ L	$\Phi = 180^\circ$ (9 o'clock)	55	65	--	degree	Note1
	$\theta$ R	$\Phi = 0^\circ$ (3 o'clock)	55	65	--		
	$\theta$ T	$\Phi = 90^\circ$ (12 o'clock)	35	45	--		
	$\theta$ B	$\Phi = 270^\circ$ (6 o'clock)	55	65	--		
Response time	TON	Normal $\theta = \Phi = 0^\circ$	--	15	30	msec	Note3
	TOFF		--	20	40	msec	
Contrast ratio	CR		250	300	--	--	Note4
Color chromaticity	WX		0.25	0.31	0.35	--	Note5
	WY		0.28	0.33	0.38	--	Note6
Luminance	L		200	250	--	cd/m <sup>2</sup>	Note6
Luminance uniformity	YU		70	75	--	--	Note7

Test Conditions :

1. VCC = 3.3V, AVDD = 9.2V, IL = 20mA (Backlight current), the ambient temperature is 25°C.
2. The test systems refer to Note 2.



Note 1 : Definition of viewing angle range

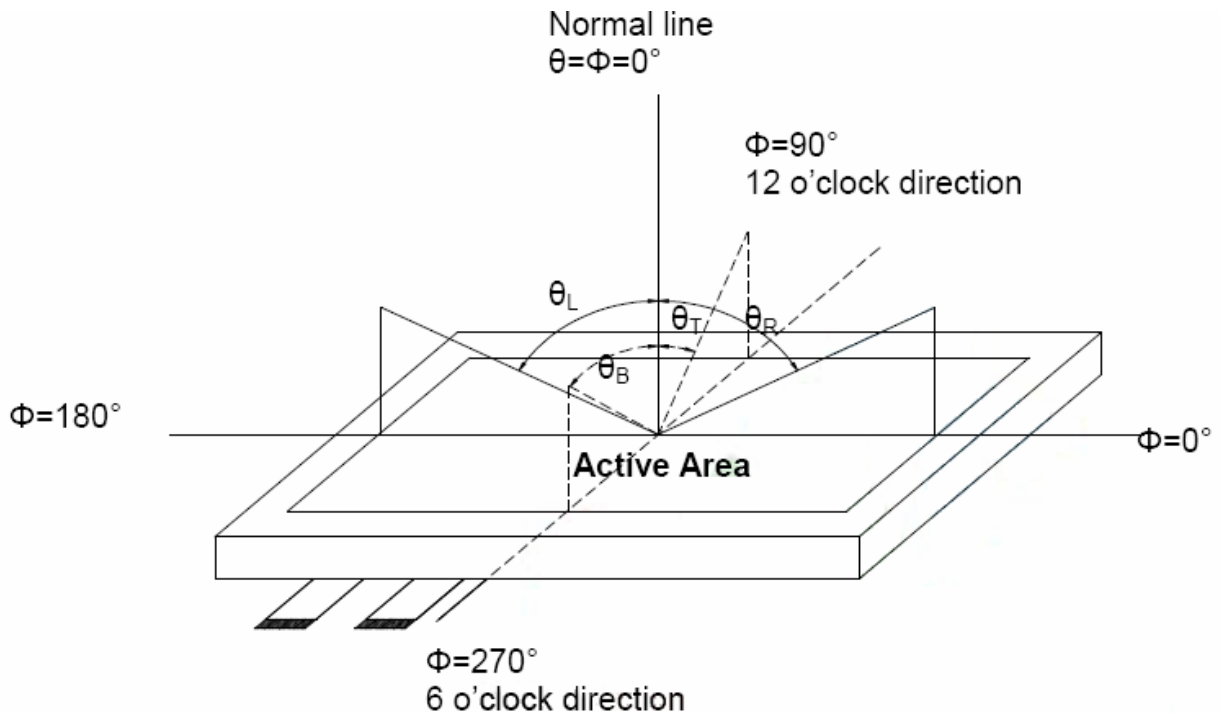

Note 2 : Definition of optical measurement system.

The optical characteristics should be measured in dark room. After 30 minutes operation, the optical properties are measured at the center point of the LCD screen. (Response time is measured by Photo detector TOPCON BM-7, other items are measured by BM-5A/Field of view :  $1^\circ$  / Height : 500mm.)

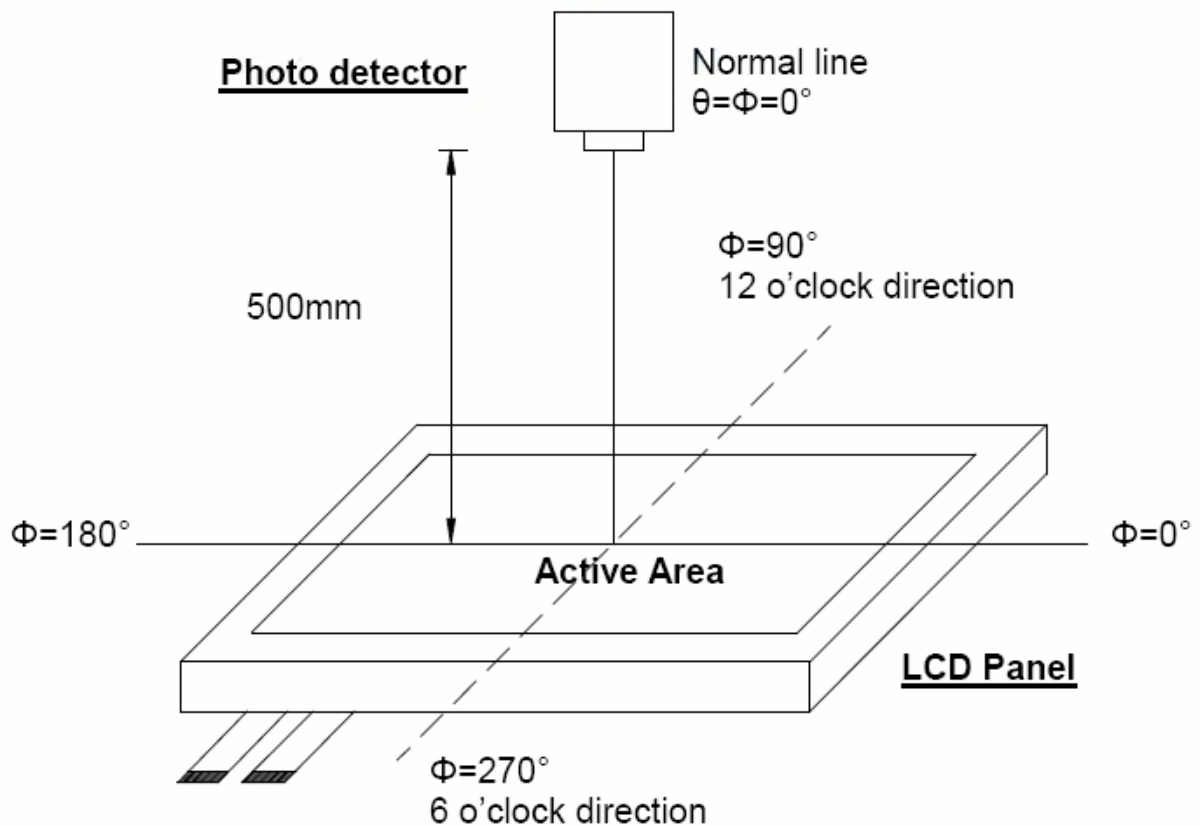

Note 3 : Definition of Response time

The response time is defined as the LCD optical switching time interval between “White” state and “Black” state. Rise time ( $T_{ON}$ ) is the time between photo detector output intensity changed from 90% to 10%. And fall time ( $T_{OFF}$ ) is the time between photo detector output intensity changed from 10% to 90%.

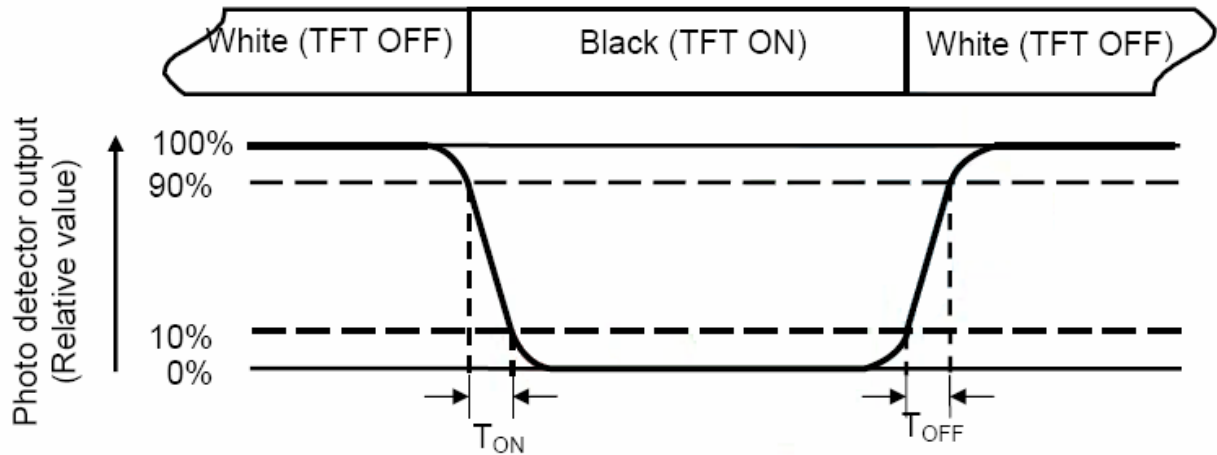

Note 4 : Definition of contrast ratio

$$\text{Contrast ratio (CR)} = \frac{\text{Luminance measured when LCD on the "White" state}}{\text{Luminance measured when LCD on the "Black" state}}$$

Note 5 : Definition of color chromaticity (CIE1931)

Color coordinated measured at center point of LCD.

Note 6 : All input terminals LCD panel must be ground when measuring the center area of the panel.

Note 7 : Definition of Luminance Uniformity

Active area is divided into 9 measuring areas (Refer to bellow figure). Every measuring point is placed at the center of each measuring area.

$$\text{Luminance Uniformity (Yu)} = \frac{B_{\min}}{B_{\max}}$$

L ----- Active area length      W ----- Active area width

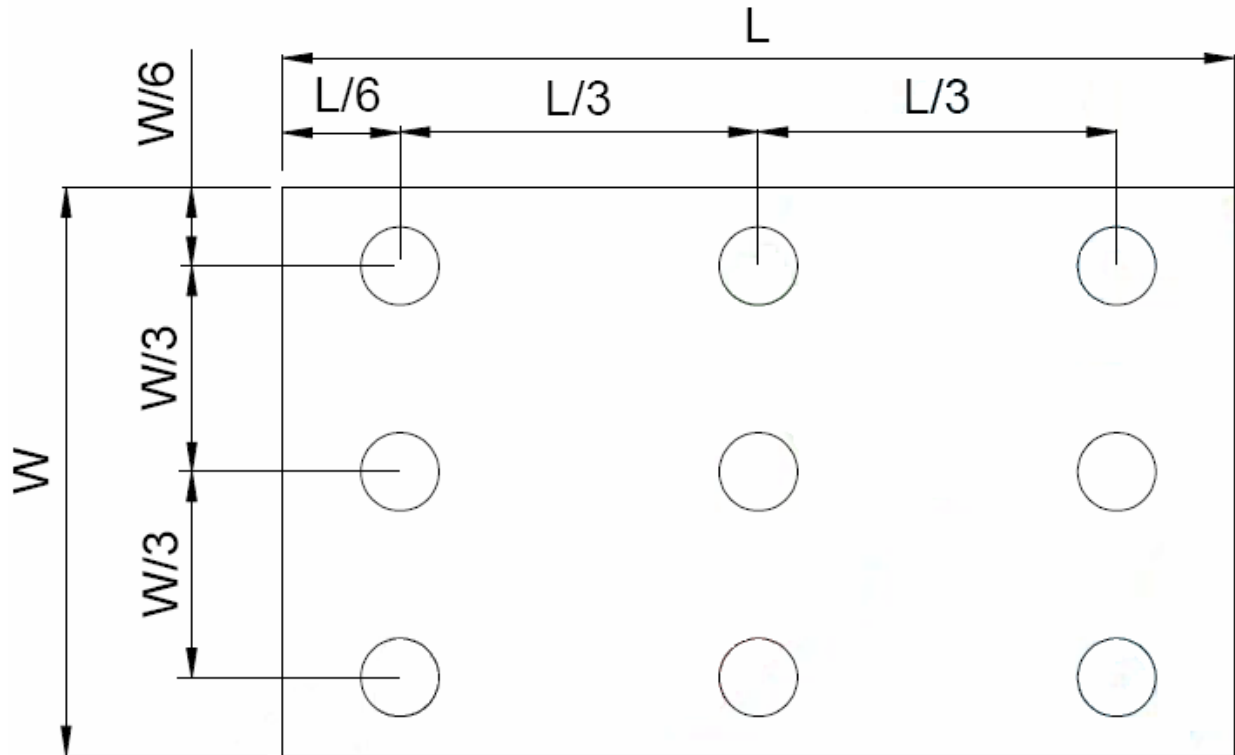

$B_{\max}$  : The measured maximum luminance of all measurement position.

$B_{\min}$  : The measured minimum luminance of all measurement position.

## 6. INTERFACE

### TFT LCD Panel Driving Section

Pin No.	Symbol	I/O	Description	Note
1	POL	I	Polarity selection	
2	STVD	I/O	Vertical start pulse input when U/D = H	Note 1
3	OEV	I	Output enable	
4	CKV	I	Vertical clock	
5	STVU	I/O	Vertical start pulse input when U/D = L	Note 1
6	GND	P	Power ground	
7	EDGSL	I	Select rising edge or rising/falling edge	
8	VCC	P	Power supply for digital circuit	
9	V9	I	Gamma voltage level 9	
10	VGL	P	Gate OFF voltage	
11	V2	I	Gamma voltage level 2	
12	VGH	P	Gate ON voltage	
13	V6	I	Gamma voltage level 6	
14	U/D	I	Up/down selection	Note 1,2
15	VCOM	I	Common voltage	
16	GND	P	Power ground	
17	AVDD	P	Power supply for analog circuit	
18	V14	I	Gamma voltage level 14	
19	V11	I	Gamma voltage level 11	
20	V8	I	Gamma voltage level 8	
21	V5	I	Gamma voltage level 5	
22	V3	I	Gamma voltage level 3	
23	GND	P	Power ground	
24	R5	I	Red data (MSB)	
25	R4	I	Red data	
26	R3	I	Red data	
27	R2	I	Red data	
28	R1	I	Red data	
29	R0	I	Red data (LSB)	

30	GND	P	Power ground	
31	GND	P	Power ground	
32	G5	I	Green data (MSB)	
33	G4	I	Green data	
34	G3	I	Green data	
35	G2	I	Green data	
36	G1	I	Green data	
37	G0	I	Green data (LSB)	
38	STHL	I/O	Horizontal start pulse input when R/L = H	Note 1
39	REV	P	Control signal are inverted or not	
40	GND	I	Power ground	
41	DCLK	I	Sample clock	
42	DVDD	P	Voltage for digital circuit	
43	STHR	I/O	Horizontal start pulse input when R/L = L	Note 1
44	LD	I	Latches the polarity of outputs and switches the new data to outputs	
45	B5	I	Blue data (MSB)	
46	B4	I	Blue data	
47	B3	I	Blue data	
48	B2	I	Blue data	
49	B1	I	Blue data	
50	B0	I	Blue data (LSB)	
51	R/L	I	Right / left selection	Note 1,2
52	V1	I	Gamma voltage level 1	
53	V4	I	Gamma voltage level 4	
54	V7	I	Gamma voltage level 7	
55	V10	I	Gamma voltage level 10	
56	V12	I	Gamma voltage level 12	
57	V13	I	Gamma voltage level 13	
58	AVDD	P	Voltage for analog circuit	
59	GND	P	Power ground	
60	VCOM	I	Common voltage	

I : input, O : output, P : power

Note 1: Selection of scanning mode

Setting of scan control input		IN/OUT state for start pulse				Scanning direction
U/D	R/L	STVD	STVU	STHR	STHL	
GND	VCC	O	I	O	I	Up to down, left to right
VCC	GND	I	O	I	O	Down to up, right to left
GND	GND	O	I	I	O	Up to down, right to left
VCC	VCC	I	O	O	I	Down to up, left to right

Note 2 : Definition of scanning direction.

Refer to the figure as below :

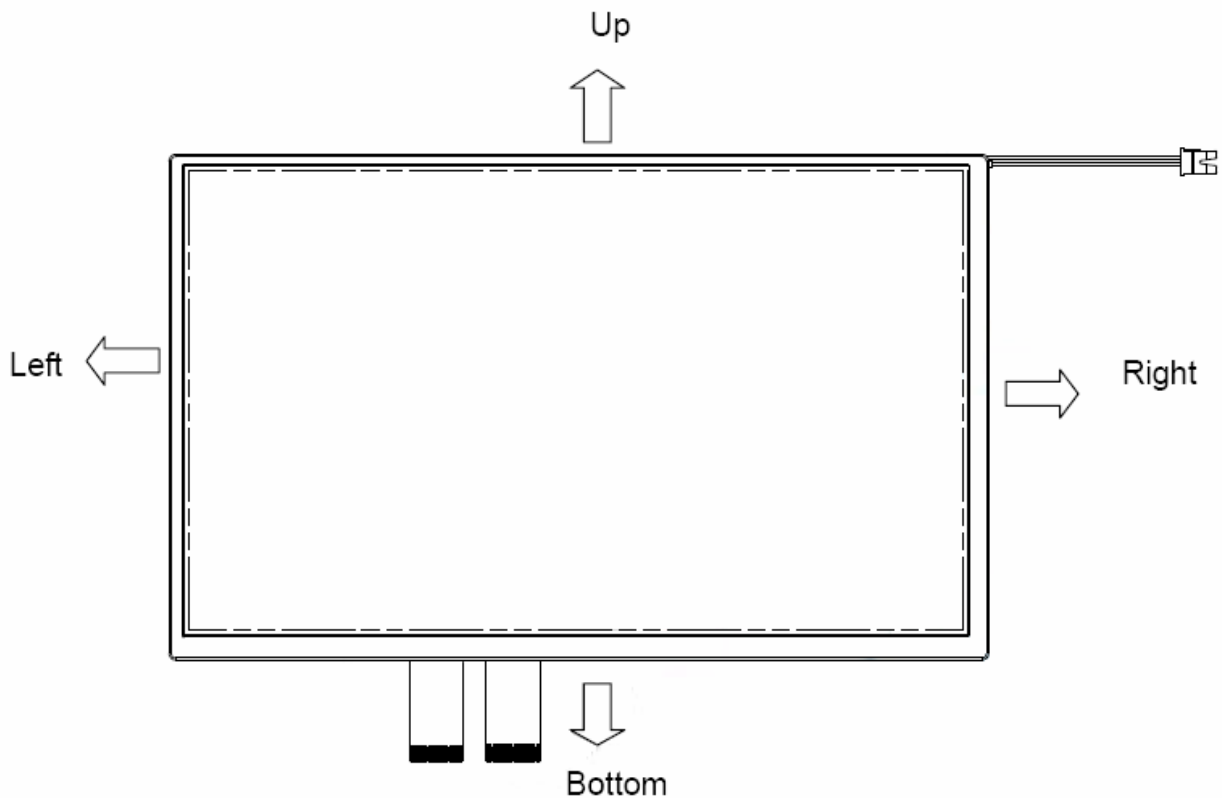

### Backlight Unit Section

Pin No.	Symbol	I/O	Description	Note
1	HI	P	Power supply for backlight unit	Pink
2	GND	P	Ground for backlight unit	White

**7. INPUT SIGNAL :**  
**7-1 Timing Specification**

Item	Symbol	Values			Unit	Note
		Min.	Typ.	Max.		
DCLK frequency	Fdclk	--	40	45	MHz	
DCLK cycle	Tcph	22	25	--	ns	
DCLK pulse width	Tcw	8	--	--	ns	
Data set-up time	Tsu	4	--	--	ns	
Date hold time	Thd	1	--	--	ns	
Time that the last data to LD	Tld	1	--	--	Tcph	
Pulse width of LD	Twld	2	--	--	Tcph	
Time that LD to STHL/R	Tlds	5	--	--	Tcph	
POL set-up time	Tpsu	6	--	--	ns	
POL hold time	Tphd	6	--	--	ns	
CKV frequency	Fvclk	--	--	200	KHz	
CKV rise time	Trck	--	--	100	ns	
CKV falling time	Tfck	--	--	100	ns	
CKV pulse width	Pwclk	500	--	--	ns	
Horizontal display timing range	Tdh	--	800	--	Tcph	
Horizontal timing range	Th	--	1056	--	Tcph	
STVU/D setup time	Tsuv	200	--	--	ns	
STVU/D hold time	Thdv	300	--	--	ns	
STVU/D delay time	Tdt	--	--	500	ns	
Driver output delay time	Tdo	--	--	900	ns	
Output rise time	Ttlh	--	500	1000	ns	
Output falling time	Tthl	--	400	800	ns	
OEV pulse width	Twcl	1	--	--	ns	
OEV to Driver output delay time	Toe	--	--	900	Ns	
Horizontal lines per field	Tv	512	525	610	Tdh	
Vertical display timing range	Tvd	--	480	--	Tdh	

## 7-2 Timing Characteristic

Timing Diagram1 (CHNSL="1", Default)

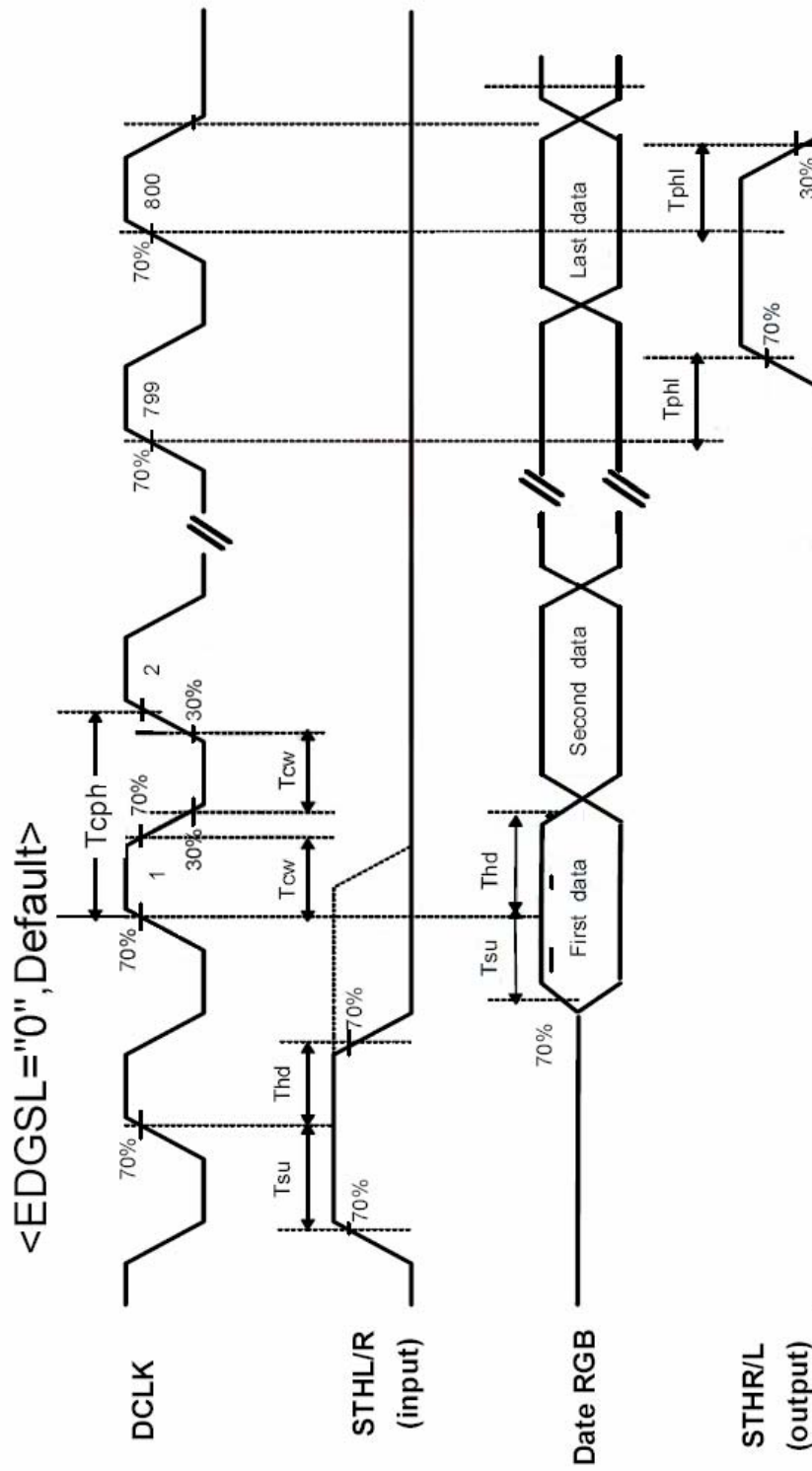

operation model 1



< EDGSL = "1" >

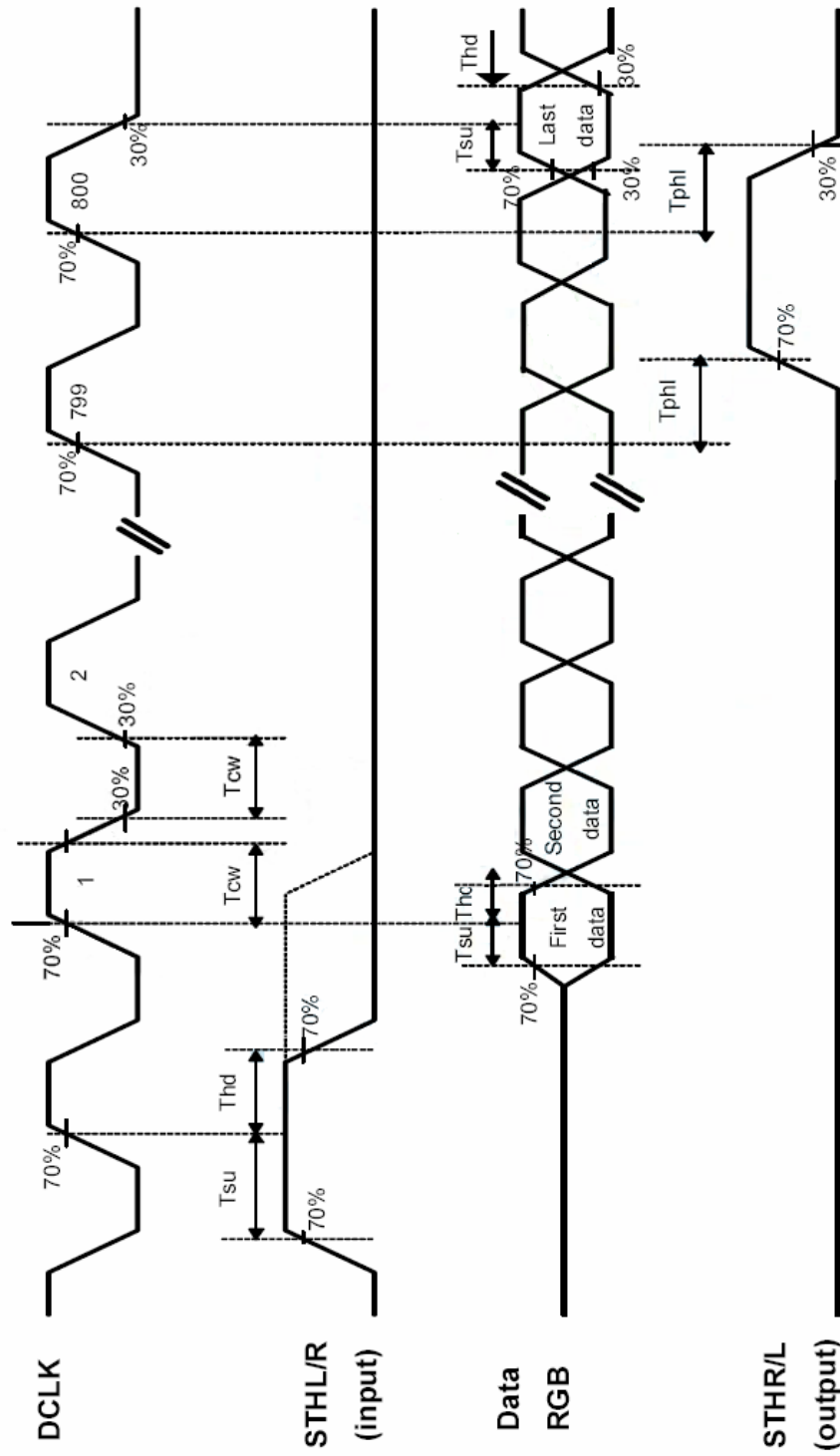

operation model 2

Timing Diagram 2

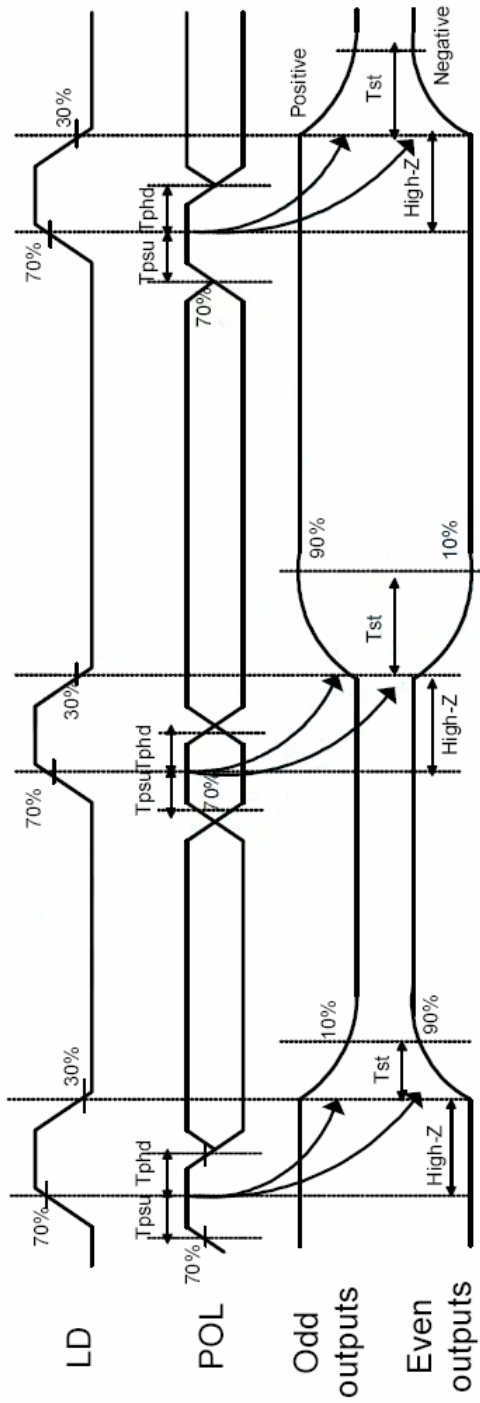
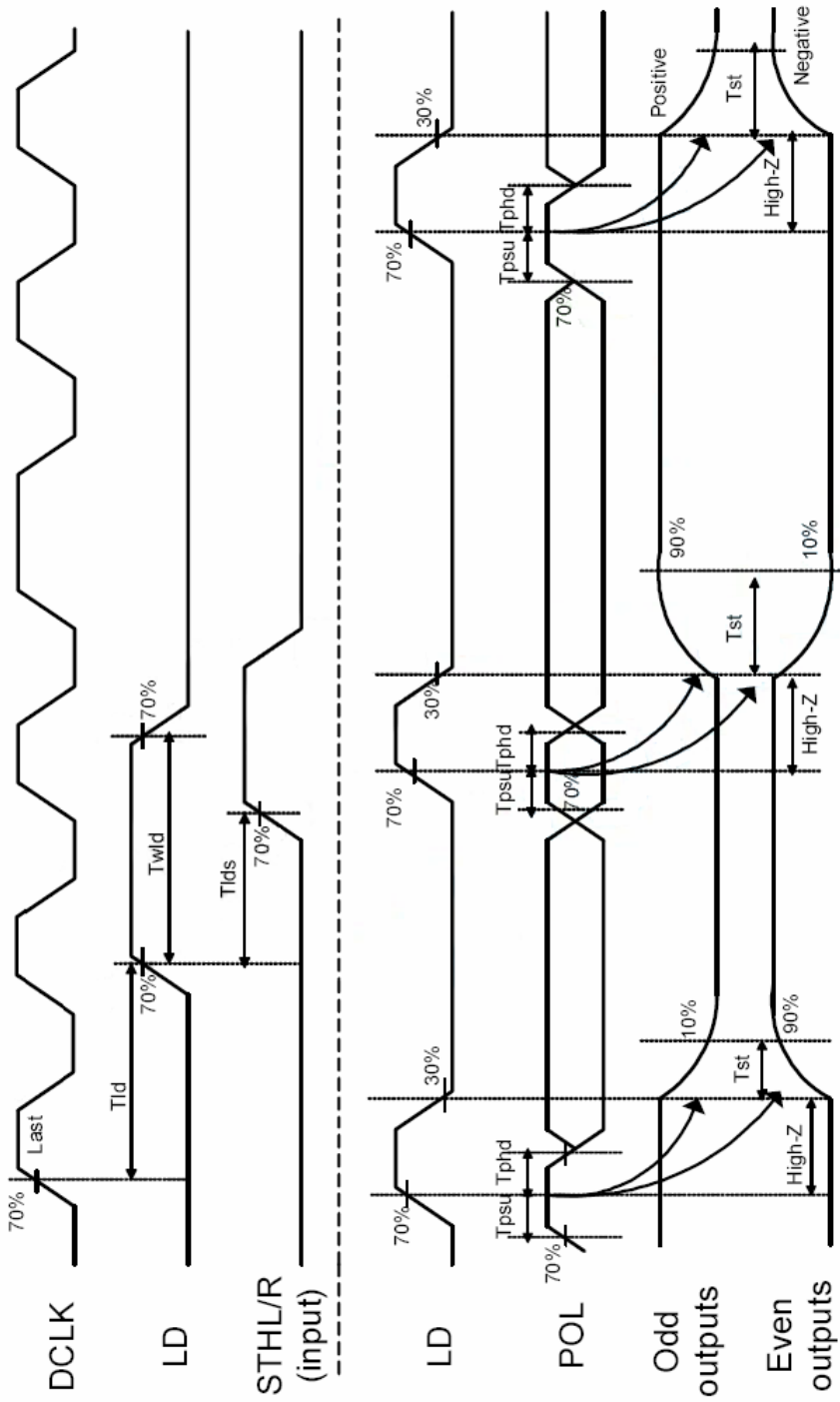

Horizontal timing 1

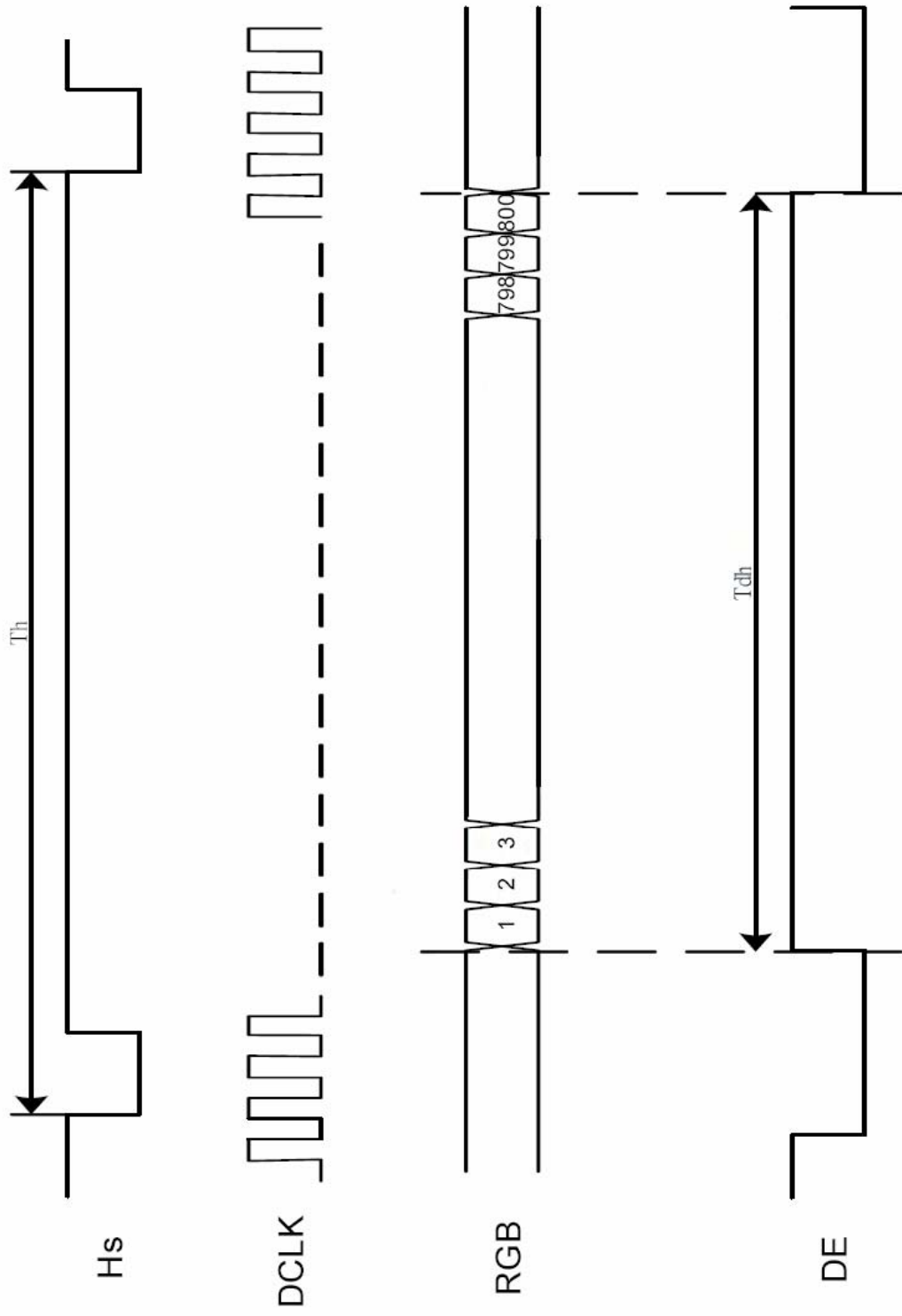

Horizontal timing 2

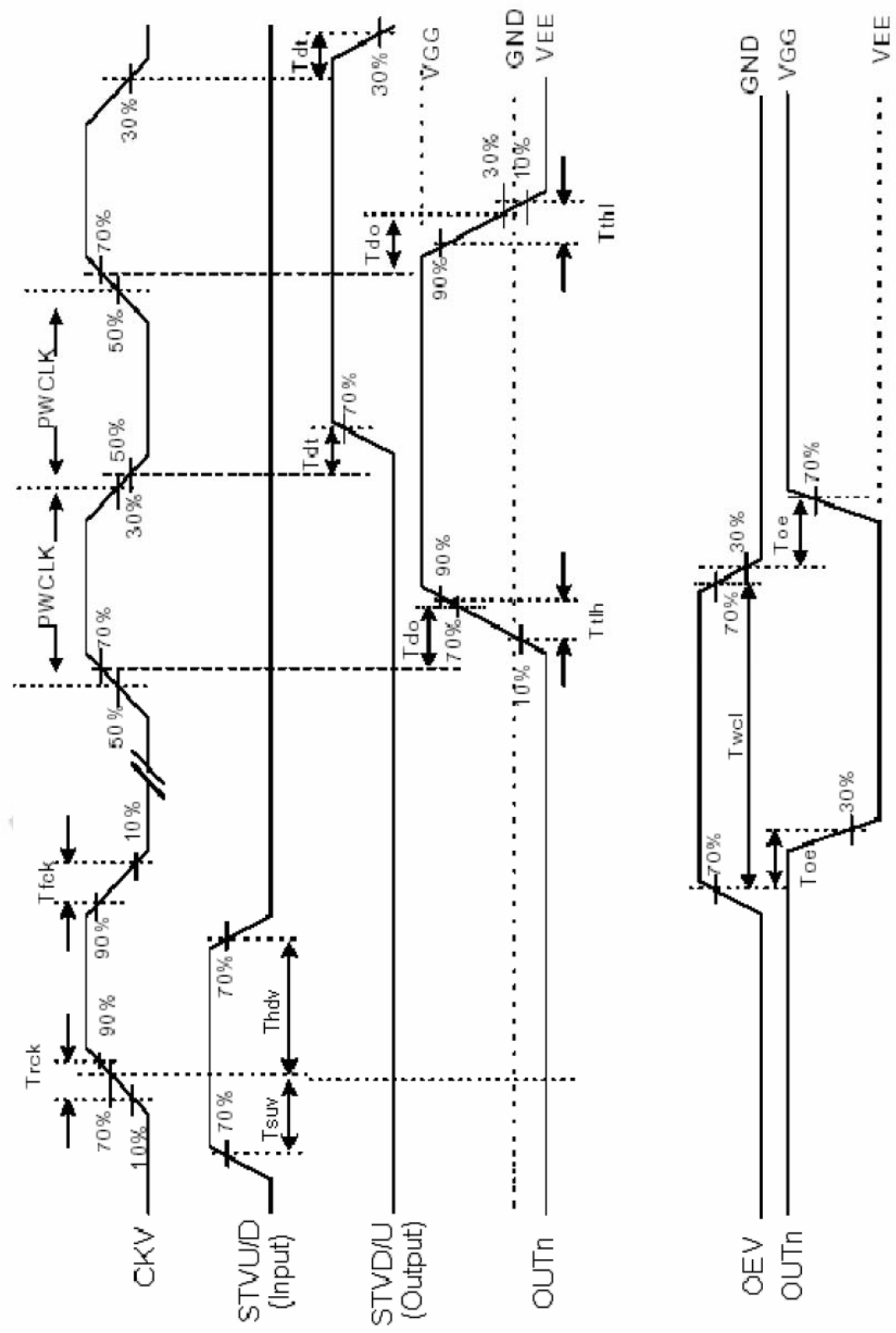

Vertical shift clock timing

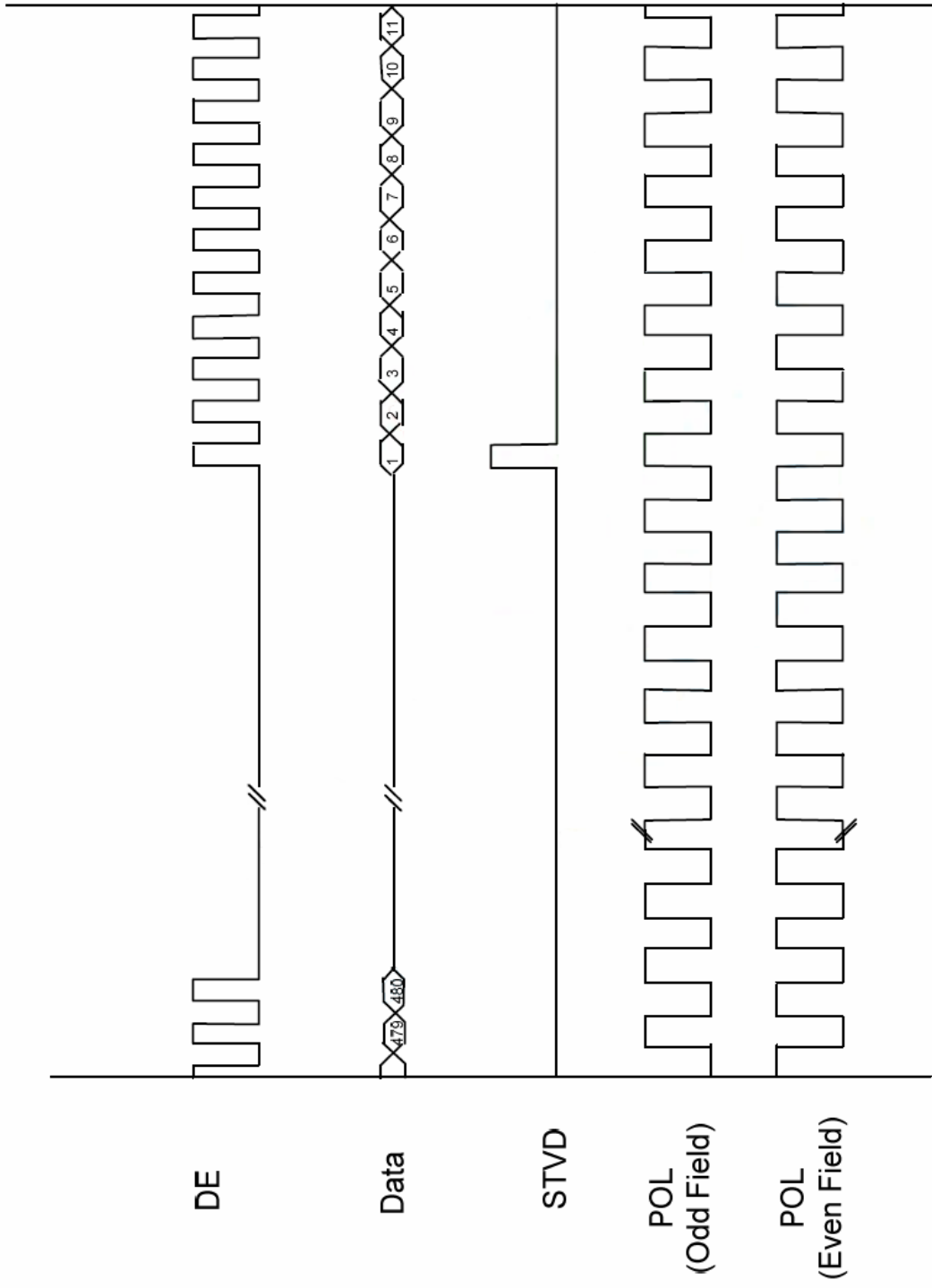

Vertical timing (from up to down)

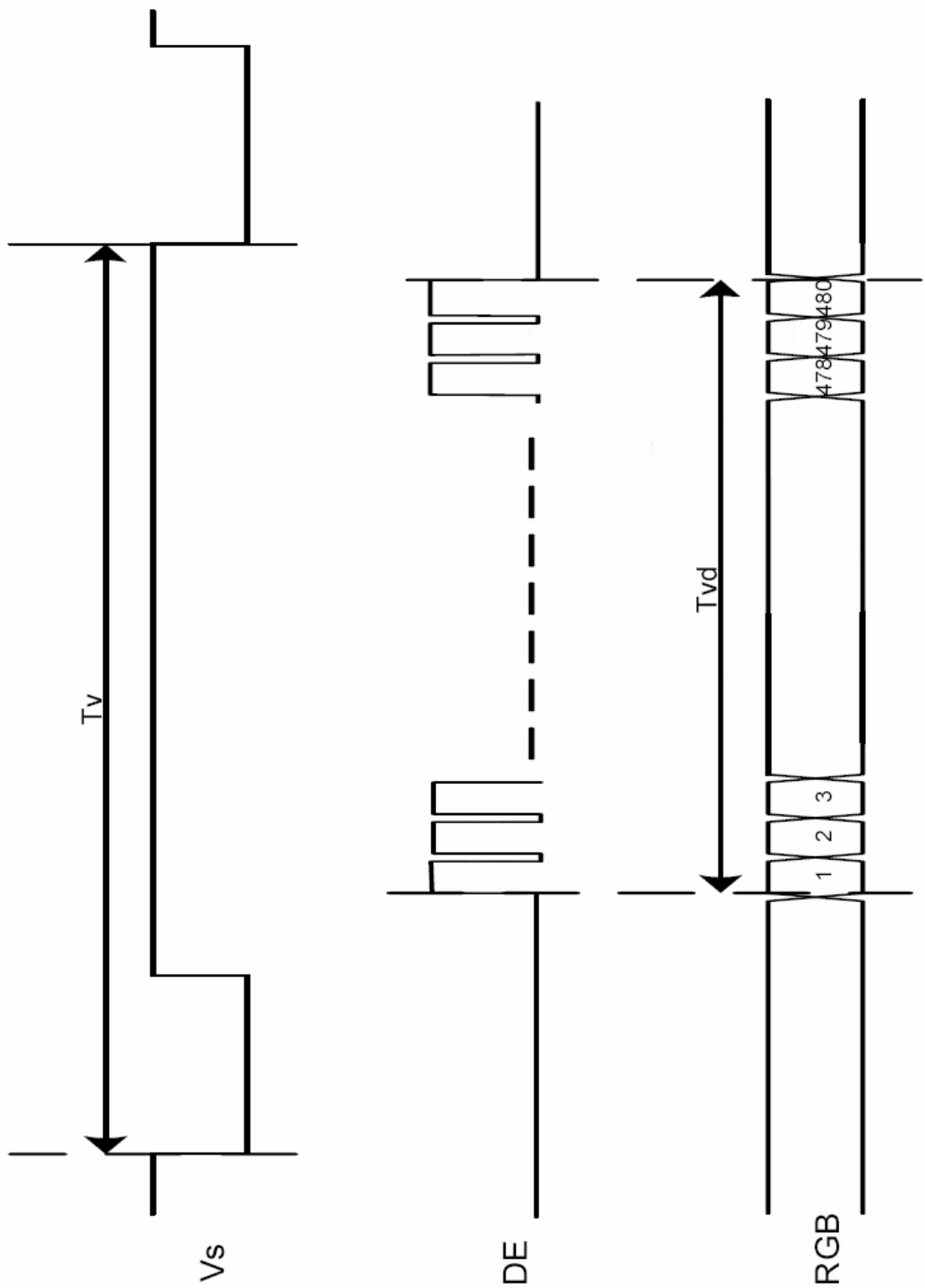

Vertical timina

## 8. RELIABILITY TEST CONDITIONS

(Note 3)

Item	Test Conditions	Note
High Temperature Storage	Ta = 85°C 240 hrs	Note 1
Low Temperature Storage	Ta = -30°C 240 hrs	Note 1
High Temperature Operation	Ts = 85°C 240 hrs	Note 2
Low Temperature Operation	Ta = -30°C 240 hrs	Note1
Operate at High Temperature and Humidity	+60°C, 90%RH 240 hrs	
Thermal Shock	-30°C /30 min ~ +85°C /30 min for a total 100 cycles, Start with cold temperature and end with high temperature	
Vibration Test	Frequency range : 10 ~ 55Hz Stroke : 1.5mm Sweep : 10Hz ~ 55Hz ~ 10Hz 2 hours for each direction of X. Y. Z. (6 hours for total)	
Mechanical Shock	100G 6ms, ±X, ±Y, ±Z 3 times for each direction	
Package Vibration Test	Random Vibration : 0.015G*G/Hz from 5-200HZ, -6dB/Octave from 200-500Hz 2 hours for each direction of X. Y. Z. (6 hours for total)	
Package Drop Test	Height : 60 cm 1 comer, 3 edges, 6 surfaces	
Electro Static Discharge	±2KV, Human Body Mode, 100pF/1500Ω	

Note 1 : Ta is the ambient temperature of samples.

Note 2 : Ts is the temperature of panel's surface.

Note 3 : In the standard condition, there shall be no practical problem that man affect the display function.

## **9. General Precautions**

### **9-1 Safety**

Liquid crystal is poisonous. Do not put it your mouth. If liquid crystal touches your skin or clothes, wash it off immediately by using soap and water.

### **9-2 Handling**

1. The LCD panel is plate glass. Do not subject the panel to mechanical shock or to excessive force on its surface.

2. The polarizer attached to the display is easily damaged. Please handle it carefully to avoid scratch or other damages.

3. To avoid contamination on the display surface, do not touch the module surface with bare hands.

4. Keep a space so that the LCD panels do not touch other components.

5. Put cover board such as acrylic board on the surface of LCD panel to protect panel from damages.

6. Transparent electrodes may be disconnected if you use the LCD panel under environmental conditions where the condensation of dew occurs.

7. Do not leave module in direct sunlight to avoid malfunction of the ICs.

### **9-3 Static Electricity**

1. Be sure to ground module before turning on power or operation module.

2. Do not apply voltage which exceeds the absolute maximum rating value.

### **9-4 Storage**

1. Store the module in a dark room where must keep at  $+25\pm 10^{\circ}\text{C}$  and 65%RH or less.

2. Do not store the module in surroundings containing organic solvent or corrosive gas.

3. Store the module in an anti-electrostatic container or bag.

### **9-5 Cleaning**

1. Do not wipe the polarizer with dry cloth. It might cause scratch.

2. Only use a soft sloth with IPA to wipe the polarizer, other chemicals might permanent damage to the polarizer.



# 10. OUTLINE DIMENSION

