

AMP DISPLAY INC.

A Brighter Solution

SPECIFICATIONS

CUSTOMER	
CUSTOMER PART NO.	
AMP PART NO.	AM-800480RBTMQW-TA1H-L
APPROVED BY	
DATE	

- Approved For Specifications**
- Approved For Specifications & Sample**

AMP DISPLAY INC

9856 SIXTH STREET RANCHO CUCAMONGA CA 91730
 TEL: 909-980-13410 FAX: 909-980-1419
 WWW.AMPDISPLAY.COM

APPROVED BY	CHECKED BY	ORGANIZED BY

RECORD OF REVISION

Revision Date	Page	Contents	Editor
2012/03/13	--	New Release	Rober
2012/3/29	6	Correct the LED life time	Rober

1. Features

7 inch module is a color active matrix thin film transistor (TFT) liquid crystal display (LCD) that uses amorphous silicon TFT as a switching device. This model is composed of a TFT LCD panel, a driving circuit , a back light system and capacitive touch panel . This TFT LCD has a 7.0 (16:9) inch diagonally measured active display area with WVGA (800 horizontal by 480 vertical pixel) resolution.

- (1) Construction: 7" a-Si TFT active matrix, White LED Backlight.
- (2) Resolution (pixel): 800(R.G.B) X 480.
- (3) Number of the Colors : 262K colors (R , G , B 6 bit digital each).
- (4) LCD type : Transmissive , normally White.
- (5) Viewing Direction 6 O'clock.
- (6) LVDS Interface.
- (7) Touch Panel with USB controller.
- (8) Reflective ratio 0.5% ~ 2%

2. PHYSICAL SPECIFICATIONS

Item	Specifications	unit
LCD size	7 inch (Diagonal)	
Outline Dimension (Include connecter)	165.0 x 104.44 x 7.76 (typ.)	mm
Number of Pixel	800 RGB (H) x 480 (V)	pixels
Pixel pitch	0.1905 (H) x 0.1905 (V)	mm
Pixel arrangement	RGB Vertical stripe	
Display mode	Normally white	
Back-light	Single LED (Side-Light type)	
Brightness	400 nit	cd/m ²
Contrast ratio	400 : 1	
Power consumption (B/L system)	4 (max.)	W

3. ABSOLUTE MAX. RATINGS

3-1 Electrical Absolute Rating

3-1-1 TFT LCD Module

Item	Symbol	Values		UNIT	Note
		Min.	Max.		
Power voltage	VCC	-0.5	4.0	V	GND=0V
Voltage range at any terminal		-0.5	VCC+0.3	V	

3-2 Environment Absolute Rating

Item	Symbol	Min.	Max.	Unit	Note
Operating Temperature	Topa	-20	70	°C	
Storage Temperature	Tstg	-30	80	°C	

4. ELECTRICAL CHARACTERISTICS

4-1 TFT LCD Module voltage

		MIN	NOM	MAX	UNIT
V_{CC}	Supply voltage	3	3.3	3.6	V
V_{IH}	High-level input voltage (\overline{SHTDN})	2			V
V_{IL}	Low-level input voltage (\overline{SHTDN})			0.8	V
$ V_{ID} $	Magnitude differential input voltage	0.1		0.6	V
V_{IC}	Common-mode input voltage	$\frac{ V_{ID} }{2}$		$2.4 - \frac{ V_{ID} }{2}$	V

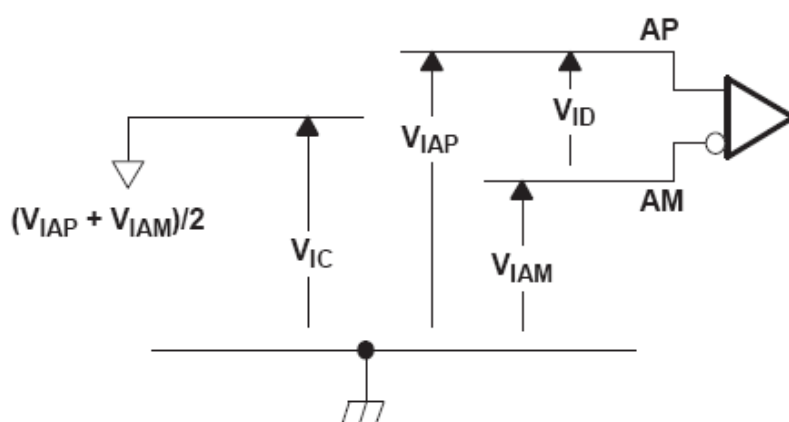

ITEM	SYMBOL	MIN	TYP	MAX	UNIT	CONDITION
Power Supply Voltage For LCD	V_{CC}	3.0	3.3	3.6	V	
Power Supply Current For LCD	I_{CC}	-	180	230	mA	Black pattern
Power Supply Voltage For LED Driver	V_{LED}	-	5.0	5.5	V	
ADJ signal frequency	f_{PWM}	100	50K	200K	Hz	
ADJ signal logic level High	V_{IH}	-	3.3	5.0	V	
ADJ signal logic level Low	V_{IL}	-	-	0.5	V	
ADJ Input Voltage	V_{ADJ}	-	3.3	-	V	duty=100%

4-2 Backlight Unit

ITEM	SYMBOL	MIN	TYP	MAX	UNIT	CONDITION
LED Backlight Voltage	V_{BL}	8.4	9.0	10.8	V	For reference
LED Backlight Current	I_{BL}	-	180	-	mA	$T_a=25^{\circ}\text{C}$
LED Life Time	-	--	40K	--	Hour	Note (2)

Note (1) The constant current source is needed for white LED back-light driving.

When LCM is operated over 60 deg.C ambient temperature, the I_{LED} of the LED back-light should be adjusted to 135mA max

Note (2) Brightness to be decreased to 50% of the initial value.

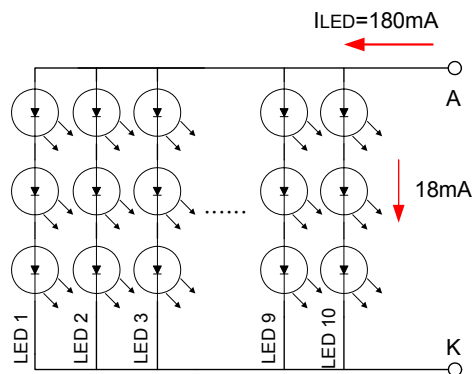

LED Light Bar Circuit

Note(3) VLEDADJ is PWM signal input. It is for brightness control.

ITEM	SYMBOL	MIN	TYP	MAX	UNIT
ADJ signal frequency	f_{PWM}	100	50K	200K	Hz
ADJ signal logic level High	V_{IH}	2V	--	VLED (5.0V)	V
ADJ signal logic level Low	V_{IL}	0	--	0.5	V

5. Optical Specifications

5-1 Optical specification

Item		Symbol	Condition	Min.	Typ.	Max.	Unit	Note
Viewing Angle	Front	θf	$CR \geq 10$	55	60	--	deg.	(1)(2)(3)
	Back	θb		55	70	--		
	Left	θl		65	70	--		
	Right	θr		65	70	--		
Contrast ratio		CR	$\Theta = \Phi = 0^\circ$	250	400	--	--	(1)(3)
Response Time		T_r	$\Theta = \Phi = 0^\circ$	--	5	10	ms	(1)(4)
		T_f		--	11	16	ms	(1)(4)
Color chromaticity	White	W_x	$\Theta = \Phi = 0^\circ$	0.239	0.299	0.359	--	(1)
		W_y		0.268	0.328	0.388		
Luminance		L	$\Theta = \Phi = 0^\circ$	--	400	--	cd/m ²	(1)(5)
Luminance Uniformity		ΔL	$\Theta = \Phi = 0^\circ$	70	--	--	%	(1)(5)(6)

Note 1: Ta=25°C. To be measured on the center area of panel after 10 minutes operation.

Note 2: Definition of Viewing Angle

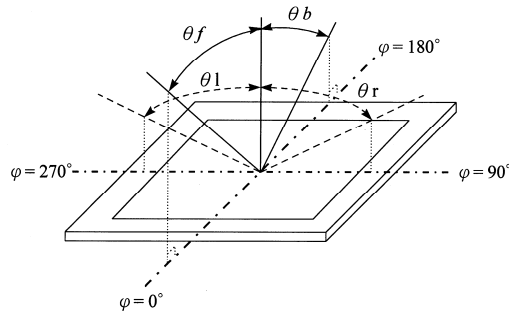

Note 3: Definition of contrast ratio:

Contrast ratio is calculated with the following formula.

$$\text{Contrast ratio(CR)} = \frac{\text{Photo detector output when LCD is at "White" state}}{\text{Photo detector Output when LCD is at "Black" state}}$$

Note 4: Definition of response time:

The output signals of photo detector are measured when the input signals are changed from "black" to "white" (falling time) and from "white" to "black" (rising time) respectively. The response time is defined as the time interval between the 10% and 90% of amplitudes. Refer to figure as below.

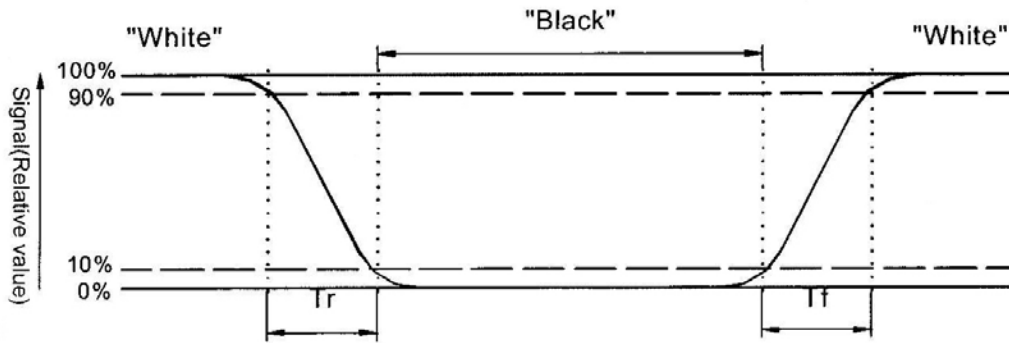

Note 5 : Luminance is measured at point 5 of the display.

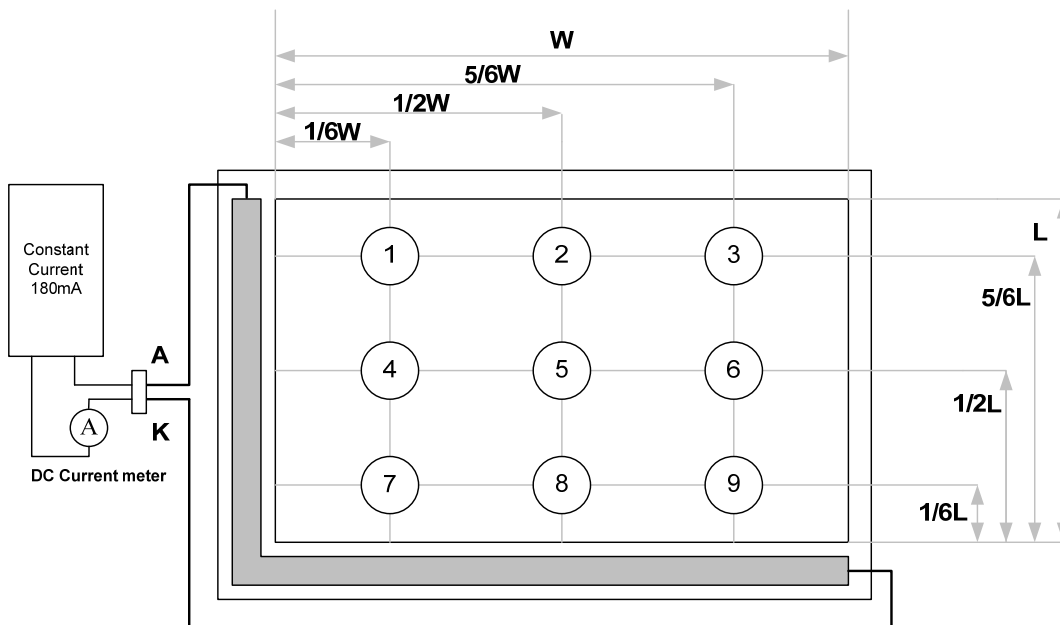

Note 6 : Definition of Luminance Uniformity

$$\Delta L = [L(\text{min.}) \text{ of } 9 \text{ points} / L(\text{max.}) \text{ of } 9 \text{ points}] \times 100\%$$

6. Touch Panel ELECTRICAL SPECIFICATION

6-1. Basic Characteristic

ITEM	SPECIFICATION
Interface Type	Projective Capacitive Multi-Touch Panel
Activation	Two-fingers or Signal-finger

6-2. Operation Environmental Characteristic

ITEM	SPECIFICATION
Operation Temperature	-20~70°C
Storage Temperature	-30~80°C

6-3. Optical Characteristic

ITEM	SPECIFICATION
Transmittance	80% (Typ)

【Notes】

(1) UV-V is 400nm~700nm Spectrum Transmittance (Reference: Air)

(2) Definition of Transmittance

$T(\%) = \frac{\text{White Luminance Touch on LCM}}{\text{LCM White Luminance}}$

7. INTERFACE

7-1 Touch Panel Interface

Pin No.	Symbol	Function
1	GND	USB POWER GND
2	D-	USB Data -
3	D+	USB Data +
4	VDD	USB POWER 5V
5	NC	No Connection
6	NC	No Connection

7-2 LCD Control Interface

Pin No.	Symbol	Function
1	VDD	POWER SUPPLY:3.3V
2	VDD	POWER SUPPLY:3.3V
3	GND	Power Ground
4	GND	Power Ground
5	IN0-	Transmission Data of Pixels
6	IN0+	Transmission Data of Pixels
7	GND	Power Ground
8	IN1-	Transmission Data of Pixels 1
9	IN1+	Transmission Data of Pixels 1
10	GND	Power Ground
11	IN2-	Transmission Data of Pixels 2
12	IN2+	Transmission Data of Pixels 2
13	GND	Power Ground
14	CLK-	Sampling Clock
15	CLK+	Sampling Clock
16	GND	Power Ground
17	VLED	POWER SUPPLY for Backlight : 5V
18	VLED	POWER SUPPLY for Backlight : 5V
19	GND	Power Ground
20	LEDADJ	PWM SIGNAL

7.1 Block Diagram

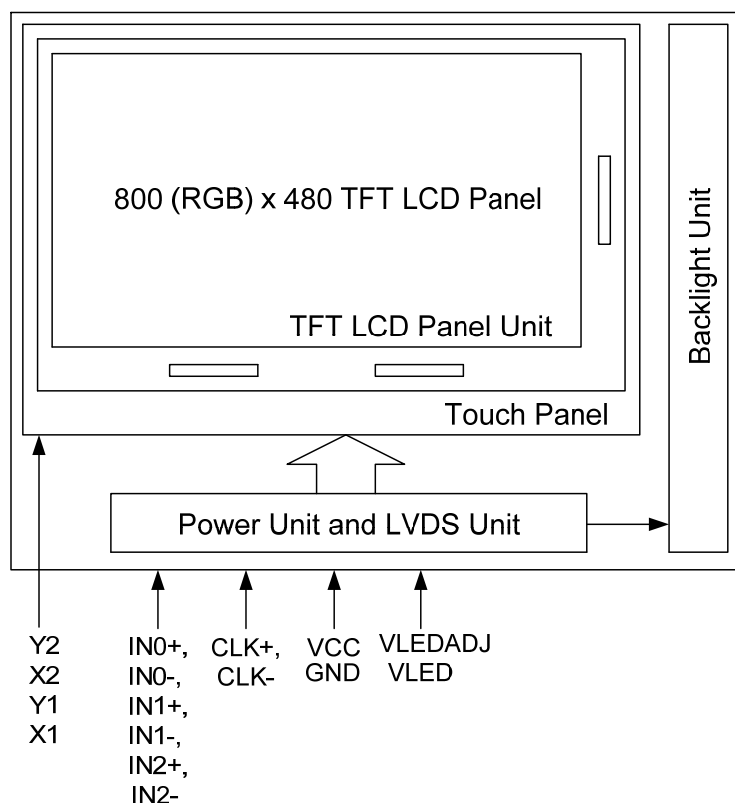

8. INPUT SIGNAL :

8-1 LVDS Signal

switching characteristics over recommended operating conditions (unless otherwise noted)

PARAMETER	TEST CONDITIONS	MIN	TYP†	MAX	UNIT
t_{su} Setup time, D0–D20 to CLKOUT↓	$C_L = 8 \text{ pF}$, See Figure 5	5			ns
t_h Data hold time, CLKOUT↓ to D0–D20		5			ns
$t_{(RSKM)}$ Receiver input skew margin§ (see Figure 7)	$t_c = 15.38 \text{ ns} (\pm 0.2\%)$, Input clock jitter < 50 ps¶	550	700		ps
t_d Delay time, CLKIN↑ to CLKOUT↓ (see Figure 7)	$V_{CC} = 3.3 \text{ V}$, $t_c = 15.38 \text{ ns} (\pm 0.2\%)$, $T_A = 25^\circ\text{C}$	3	5	7	ns
t_{en} Enable time, $\overline{\text{SHTDN}}$ to phase lock	See Figure 7	1			ms
t_{dis} Disable time, $\overline{\text{SHTDN}}$ to off state	See Figure 8	400			ns
t_t Transition time, output (10% to 90% t_r or t_f) (data only)	$C_L = 8 \text{ pF}$	3			ns
t_t Transition time, output (10% to 90% t_r or t_f) (clock only)	$C_L = 8 \text{ pF}$	1.5			ns
t_w Pulse duration, output clock		0.50 t_c			ns

† All typical values are at $V_{CC} = 3.3 \text{ V}$, $T_A = 25^\circ\text{C}$.

§ The parameter $t_{(RSKM)}$ is the timing margin available to allocate to the transmitter and interconnection skews and clock jitter. The value of this parameter at clock periods other than 15.38 ns can be calculated from $t_{(RSKM)} = t_c/14 - 550 \text{ ps}$.

¶ |Input clock jitter| is the magnitude of the change in input clock period.

PARAMETER MEASUREMENT INFORMATION

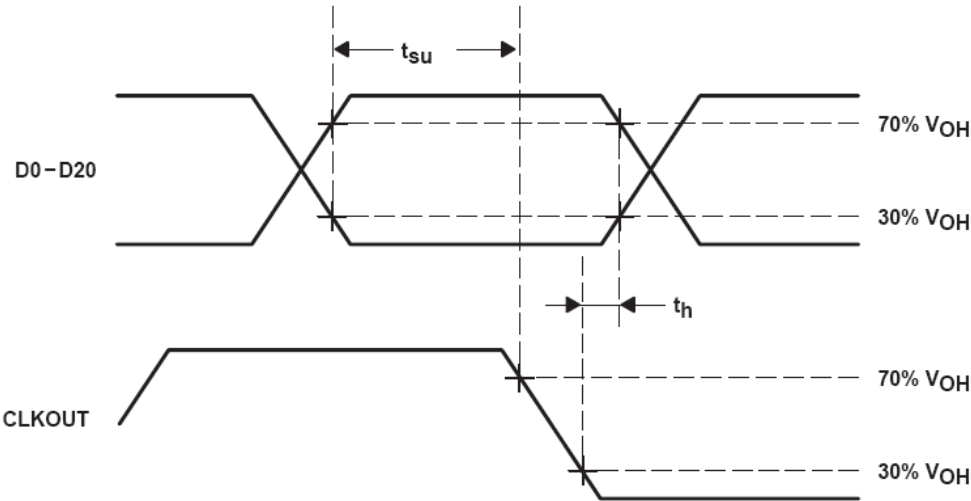
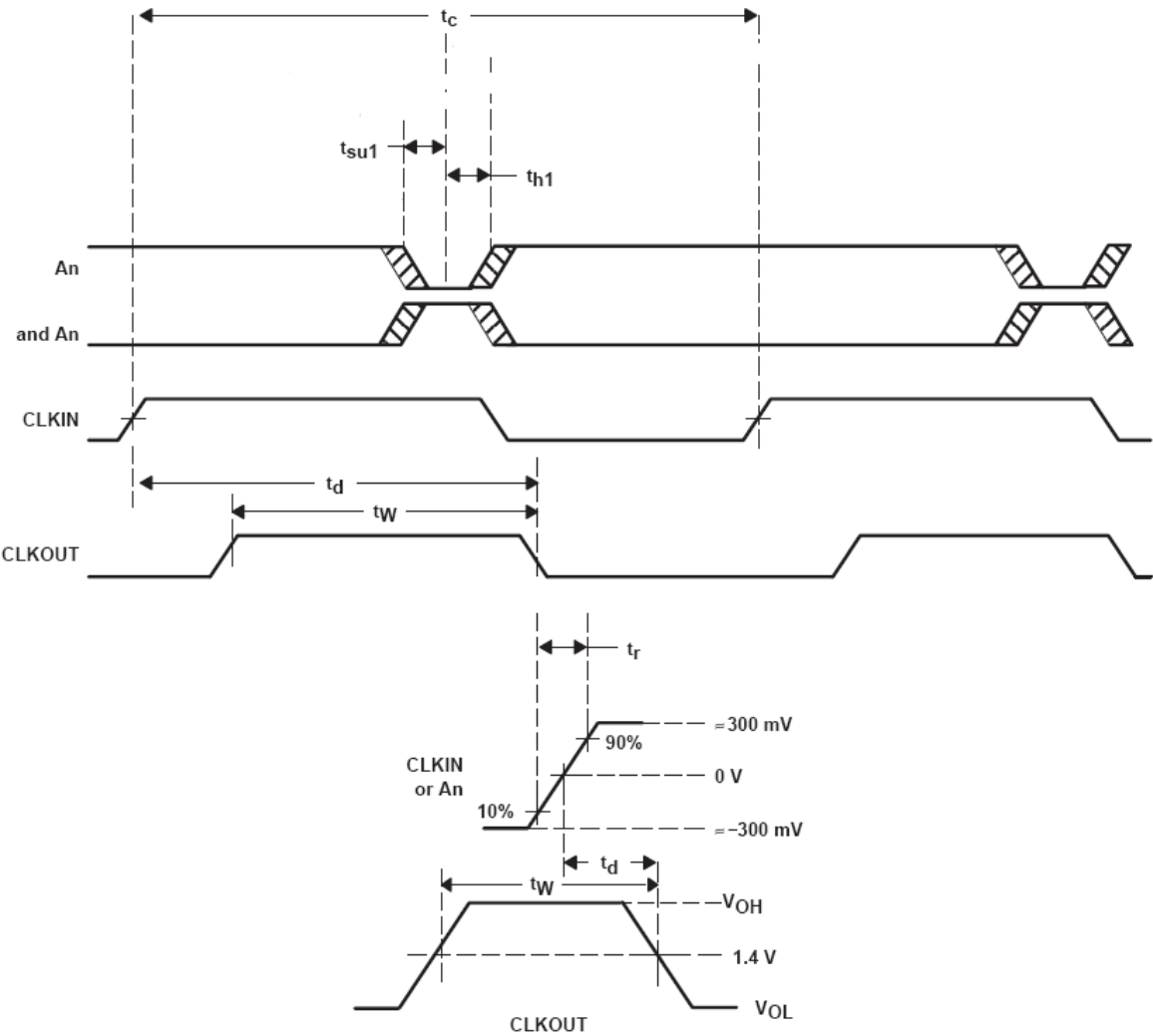

Figure 5. Setup and Hold Time Waveforms



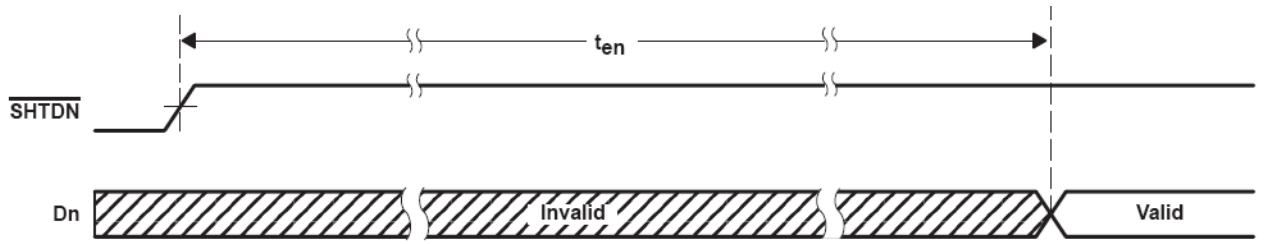

Figure 7. Enable Time Waveforms

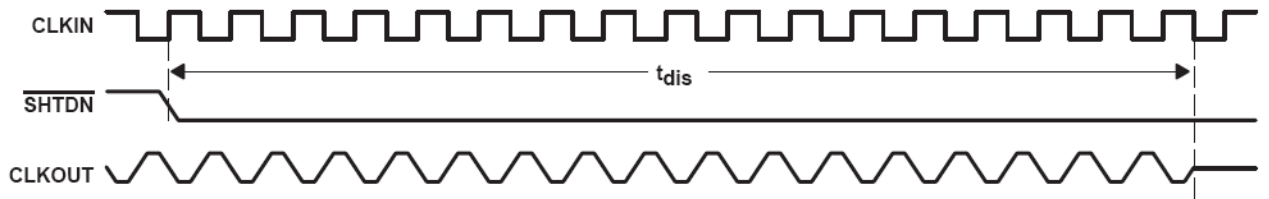

Figure 8. Disable Time Waveforms

9. DISPLAYED COLOR AND INPUT DATA

	Color & Gray Scale	DATA SIGNAL																	
		R5	R4	R3	R2	R1	R0	G5	G4	G3	G2	G1	G0	B5	B4	B3	B2	B1	B0
Basic Color	Black	0	0	0	0	0	0	0	0	0	0	0	0	0	0	0	0	0	0
	Red(63)	1	1	1	1	1	1	0	0	0	0	0	0	0	0	0	0	0	0
	Green(63)	0	0	0	0	0	0	1	1	1	1	1	1	0	0	0	0	0	0
	Blue(63)	0	0	0	0	0	0	0	0	0	0	0	0	1	1	1	1	1	1
	Cyan	0	0	0	0	0	0	1	1	1	1	1	1	1	1	1	1	1	1
	Magenta	1	1	1	1	1	1	0	0	0	0	0	0	1	1	1	1	1	1
	Yellow	1	1	1	1	1	1	1	1	1	1	1	1	0	0	0	0	0	0
	White	1	1	1	1	1	1	1	1	1	1	1	1	1	1	1	1	1	1
Red	Black	0	0	0	0	0	0	0	0	0	0	0	0	0	0	0	0	0	0
	Red(1)	0	0	0	0	0	1	0	0	0	0	0	0	0	0	0	0	0	0
	Red(2)	0	0	0	0	1	0	0	0	0	0	0	0	0	0	0	0	0	0
	:	:	:	:	:	:	:	:	:	:	:	:	:	:	:	:	:	:	:
	Red(31)	0	1	1	1	1	1	0	0	0	0	0	0	0	0	0	0	0	0
	:	:	:	:	:	:	:	:	:	:	:	:	:	:	:	:	:	:	:
	Red(62)	1	1	1	1	1	0	0	0	0	0	0	0	0	0	0	0	0	0
	Red(63)	1	1	1	1	1	1	0	0	0	0	0	0	0	0	0	0	0	0
Green	Black	0	0	0	0	0	0	0	0	0	0	0	0	0	0	0	0	0	0
	Green(1)	0	0	0	0	0	0	0	0	0	0	0	1	0	0	0	0	0	0
	Green(2)	0	0	0	0	0	0	0	0	0	0	1	0	0	0	0	0	0	0
	:	:	:	:	:	:	:	:	:	:	:	:	:	:	:	:	:	:	:
	Green(31)	0	0	0	0	0	0	0	1	1	1	1	0	0	0	0	0	0	0
	:	:	:	:	:	:	:	:	:	:	:	:	:	:	:	:	:	:	:
	Green(62)	0	0	0	0	0	0	1	1	1	1	1	0	0	0	0	0	0	0
	Green(63)	0	0	0	0	0	0	1	1	1	1	1	1	0	0	0	0	0	0
Blue	Black	0	0	0	0	0	0	0	0	0	0	0	0	0	0	0	0	0	0
	Blue(1)	0	0	0	0	0	0	0	0	0	0	0	0	0	0	0	0	0	1
	Blue(2)	0	0	0	0	0	0	0	0	0	0	0	0	0	0	0	0	1	0
	:	:	:	:	:	:	:	:	:	:	:	:	:	:	:	:	:	:	:
	Blue(31)	0	0	0	0	0	0	0	0	0	0	0	0	0	1	1	1	1	1
	:	:	:	:	:	:	:	:	:	:	:	:	:	:	:	:	:	:	:
	Blue(62)	0	0	0	0	0	0	0	0	0	0	0	0	1	1	1	1	1	0
	Blue(63)	0	0	0	0	0	0	0	0	0	0	0	0	1	1	1	1	1	1

10. RELIABILITY TEST CONDITIONS

10.1. Scope

Specifications contain

10.1.1 Display Quality Evaluation

10.1.2 Mechanics Specification

10.2. Sampling Plan

Unless there is other agreement, the sampling plan for incoming inspection shall follow MIL-STD-105E LEVEL II.

10.2.1 Lot size: Quantity per shipment as one lot (different model as different lot).

10.2.2 Sampling type: Normal inspection, single sampling.

10.2.3 Sampling level: Level II.

10.2.4 AQL: Acceptable Quality Level

Major defect: AQL=0.65

Minor defect: AQL=1.0

10.3. Panel Inspection Condition

10.3.1 Environment:

Room Temperature: $25\pm 5^{\circ}\text{C}$.

Humidity: $65\pm 5\%$ RH.

Illumination: 300 ~ 700 Lux.

10.3.2 Inspection Distance:

35-40 cm

10.3.3 Inspection Angle:

The vision of inspector should be perpendicular to the surface of the Module.

10.3.4 Inspection time :

Perceptibility Test Time: 20 seconds max.

10.4. Display Quality

10.4.1 Function Related:

The function defects of line defect, abnormal display, and no display are considered Major defects.

10.4.2 Bright/Dark Dots:

Defect Type / Specification	G0 Grade	A Grade
Bright Dots	0	$N \leq 2$
Dark Dots	0	$N \leq 3$
Total Bright and Dark Dots	0	$N \leq 4$

[Note 1]

Judge defect dot and adjacent dot as following.

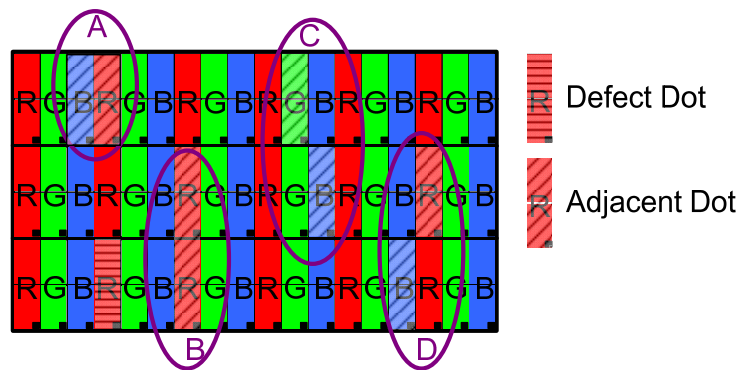

- (1) One pixel consists of 3 sub-pixels, including R,G, and B dot.(Sub-pixel = Dot)
- (2) The definition of dot: The size of a defective dot over 1/2 of whole dot is regarded as one defective dot.
- (3) Allow above (as A, B, C and D status) adjacent defect dots, including bright and dart adjacent dot. And they will be counted 2 defect dots in total quantity.
- (4) Defects on the Black Matrix, out of Display area, are not considered as a defect or counted.
- (5) There should be no distinct non-uniformity visible through 6% ND Filter within 2 sec inspection times.

10.4.3 Visual Inspection specifications:

Defect Type	Specification	Count(N)
Dot Shape (Particle, Scratch and Bubbles in display area)	$D \leq 0.2\text{mm}$	Ignored
	$0.2\text{mm} < D \leq 0.4\text{mm}$	$N \leq 3$
	$D > 0.4\text{mm}$	$N=0$
Line Shape (Particles, Scratch, Lint and Bubbles in display area)	$W \leq 0.05\text{mm}$	Ignored
	$0.05\text{mm} < W \leq 0.1\text{mm}$, $L \leq 4\text{mm}$	$N \leq 3$
	$W > 0.1\text{mm}$, $L > 4\text{mm}$	$N=0$

[Note 2] W : Width[mm], L : Length[mm], N : Number, ϕ : Average Diameter

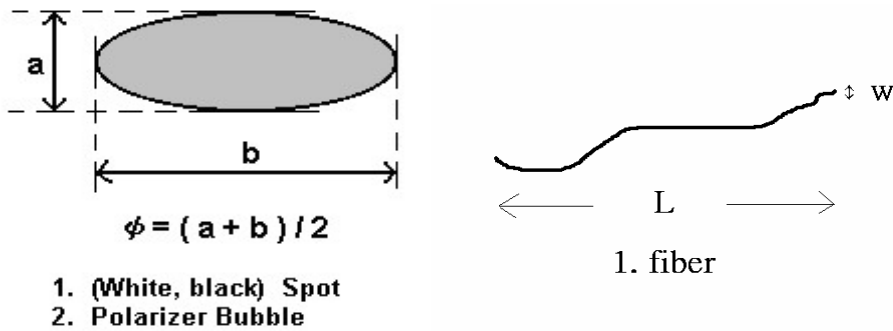

[Note 3] Bright dot is defined through 6% transmission ND Filter as following.

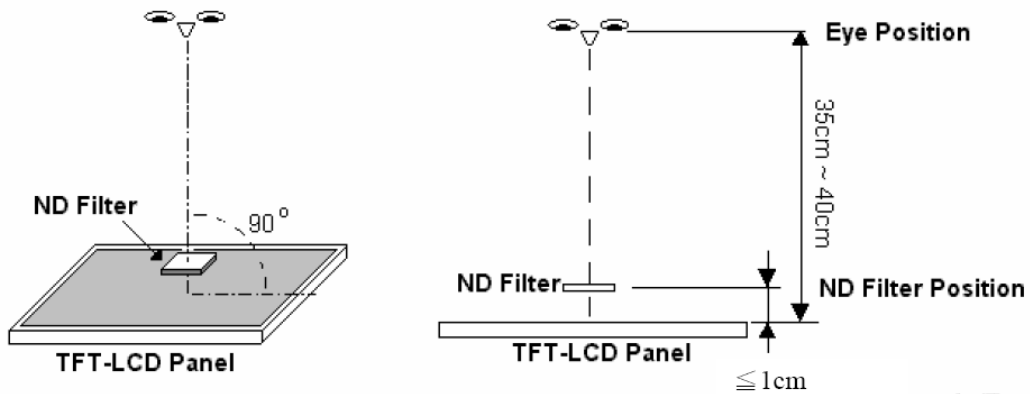

10.1. Reliability Test

Test Item	Test Conditions	Note
High Temperature Operation	70±3°C , t=240 hrs	
Low Temperature Operation	-20±3°C , t=240 hrs	
High Temperature Storage	80±3°C , t=240 hrs	1,2
Low Temperature Storage	-30±3°C , t=240 hrs	1,2
Thermal Shock Test	-10°C ~ 60°C 30 min. ~ 30 min. (1 cycle) Total 100cycle	1,2
Humidity Test	60 °C, Humidity 90%, 240 hrs	1,2
Vibration Test (Packing)	Sweep frequency : 10 ~ 500 ~ 10 Hz/1min Amplitude : 0.75mm Test direction : X.Y.Z/3 axis Duration : 30min/each axis	2

Note 1 : Condensation of water is not permitted on the module.

Note 2 : The module should be inspected after 1 hour storage in normal conditions

(15-35°C , 45-65%RH).

Definitions of life end point :

- Current drain should be smaller than the specific value.
- Function of the module should be maintained.
- Appearance and display quality should not have degraded noticeably.
- Contrast ratio should be greater than 50% of the initial value.

11. USE PRECAUTIONS

11.1. Handling precautions

- 1) The polarizing plate may break easily so be careful when handling it. Do not touch, press or rub it with a hard-material tool like tweezers.
- 2) Do not touch the polarizing plate surface with bare hands so as not to make it dirty. If the surface or other related part of the polarizing plate is dirty, soak a soft cotton cloth or chamois leather in benzine and wipe off with it. Do not use chemical liquids such as acetone, toluene and isopropyl alcohol. Failure to do so may bring chemical reaction phenomena and deteriorations.
- 3) Remove any spit or water immediately. If it is left for hours, the suffered part may deform or decolorize.
- 4) If the LCD element breaks and any LC stuff leaks, do not suck or lick it. Also if LC stuff is stuck on your skin or clothing, wash thoroughly with soap and water immediately.

11.2. Installing precautions

- 1) The PCB has many ICs that may be damaged easily by static electricity. To prevent breaking by static electricity from the human body and clothing, earth the human body properly using the high resistance and discharge static electricity during the operation. In this case, however, the resistance value should be approx. 1M Ω and the resistance should be placed near the human body rather than the ground surface. When the indoor space is dry, static electricity may occur easily so be careful. We recommend the indoor space should be kept with humidity of 60% or more. When a soldering iron or other similar tool is used for assembly, be sure to earth it.
- 2) When installing the module and ICs, do not bend or twist them. Failure to do so may crack LC element and cause circuit failure.
- 3) To protect LC element, especially polarizing plate, use a transparent protective plate (e.g., acrylic plate, glass etc) for the product case.
- 4) Do not use an adhesive like a both-side adhesive tape to make LCD surface (polarizing plate) and product case stick together. Failure to do so may cause the polarizing plate to peel off.

11.3. Storage precautions

- 1) Avoid a high temperature and humidity area. Keep the temperature between 0°C and 35°C and also the humidity under 60%.
- 2) Choose the dark spaces where the product is not exposed to direct sunlight or fluorescent light.
- 3) Store the products as they are put in the boxes provided from us or in the same conditions as we recommend.

11.4. Operating precautions

- 1) Do not boost the applied drive voltage abnormally. Failure to do so may break ICs. When applying power voltage, check the electrical features beforehand and be careful. Always turn off the power to the LC module controller before removing or inserting the LC module input connector. If the input connector is removed or inserted while the power is turned on, the LC module internal circuit may break.
- 2) The display response may be late if the operating temperature is under the normal standard, and the display may be out of order if it is above the normal standard. But this is not a failure; this will be restored if it is within the normal standard.
- 3) The LCD contrast varies depending on the visual angle, ambient temperature, power voltage etc. Obtain the optimum contrast by adjusting the LC drive voltage.
- 4) When carrying out the test, do not take the module out of the low-temperature space suddenly. Failure to do so will cause the module condensing, leading to malfunctions.
- 5) Make certain that each signal noise level is within the standard (L level: 0.2V_{dd} or less and H level: 0.8V_{dd} or more) even if the module has functioned properly. If it is beyond the standard, the module may often malfunction. In addition, always connect the module when making noise level measurements.
- 6) The CMOS ICs are incorporated in the module and the pull-up and pull-down function is not adopted for the input so avoid putting the input signal open while the power is ON.
- 7) The characteristic of the semiconductor element changes when it is exposed to light emissions, therefore ICs on the LCD may malfunction if they receive light emissions. To prevent these malfunctions, design and assemble ICs so that they are shielded from light emissions.

8) Crosstalk occurs because of characteristics of the LCD. In general, crosstalk occurs when the regularized display is maintained. Also, crosstalk is affected by the LC drive voltage. Design the contents of the display, considering crosstalk.

11.5. Other

- 1) Do not disassemble or take the LC module into pieces. The LC modules once disassembled or taken into pieces are not the guarantee articles.
- 2) The residual image may exist if the same display pattern is shown for hours. This residual image, however, disappears when another display pattern is shown or the drive is interrupted and left for a while. But this is not a problem on reliability.
- 3) AMIPRE will provide one year warrantee for all products and three months warrantee for all repairing products.

