

A Brighter Solution

AMP DISPLAY INC.

PRELIMINARY SPECIFICATIONS

8.0-in COLOR TFT MODULE W/ TOUCH

CUSTOMER:	
CUSTOMER PART NO.	
AMP DISPLAY PART NO.	AM-800600C1TMQW-T01H
APPROVED BY:	
DATE:	

APPROVED FOR SPECIFICATIONS

APPROVED FOR SPECIFICATION AND PROTOTYPES

AMP DISPLAY INC

9856 SIXTH STREET RANCHO CUCAMONGA CA 91730
TEL: 909-980-13410 FAX: 909-980-1419
WWW.AMPDISPLAY.COM

Preliminary

The contents of this document are confidential and must not be disclosed wholly or in part to any third part without the prior written consent of AMP DISPLAY

RECORD OF REVISION

Revision Date	Page	Contents	Editor
2007/9/5	- -	New Release	Edward

Preliminary

The contents of this document are confidential and must not be disclosed wholly or in part to any third part without the prior written consent of AMP DISPLAY

1. INTRODUCTION

Ampire Display Module AM800600C is a color active matrix TFT-LCD that uses amorphous silicon TFT as a switching device . This model is composed of a 8 inch TFT-LCD panel , a driving circuit, touch panel and a LED backlight system . This TFT-LCD has a high resolution (800(R.G.B) X 600) and can display up to 262,144 colors .

1-1. Features

- SVGA (4:3 diagonal) configuration
- LVDS interface
- LED Backlight & wide range operation temperature

1-2. Applications

- Portable TV
- Car PC
- Industrial application
- HMI (Human machine interface)

2. PHYSICAL SPECIFICATIONS

Item	Specifications	unit
Display resolution(dot)	800xRGB (W) x 600(H)	dots
Active area	162.0 (W) x 121.5 (H)	mm
Pixel pitch	0.2025 (W) x 0.2025 (H)	mm
Color configuration	R.G.B Vertical stripe	
Overall dimension	183.0(W)x141.0(H)x10.4(D)---(Typ)	mm
Weight	TBD	g
Surface treatment	Anti-glare	
Brightness	250 nit(typ)	cd/m ²
Contrast ratio	500 : 1	
Backlight unit	LED	
Display color	262,144	colors

Preliminary

The contents of this document are confidential and must not be disclosed wholly or in part to any third part without the prior written consent of AMP DSPLAY

3. ELECTRICAL CHARACTERISTICS

3-1 TFT LCD Module voltage

ITEM	SYMBOL	MIN	TYP	MAX	UNIT	NOTE
Power Supply Voltage	VDD	3.0	3.3	3.6	V	
Power Supply Current	IDD	--	TBD	--	mA	

3-2 Backlight unit

ITEM	SYMBOL	MIN	TYP	MAX	UNIT	NOTE
LED Voltage	VL	-	9.9	12.0	V	1)
LED Current	IL	-	20	-	mA	1)
LED life time	-	20K	-	-	Hr	2)

NOTE :

1) The LED driving condition is defined for each LED Module (3 LED Serial)

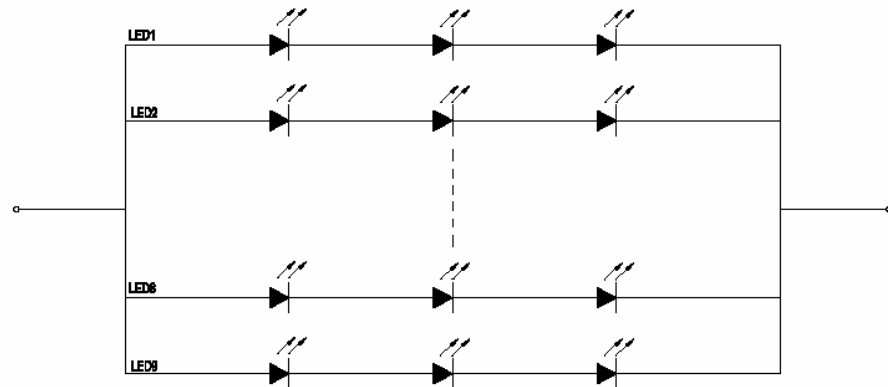

2) The LED Life Time define : Module brightness decay to 50% , $T_a=25^{\circ}\text{C}$, $I_L=20\text{mA}$

■ The constant current source is needed for white LED back-light driving.

When LCM is operated over 60°C ambient temperature, the I_{LED} of the LED back-light should be

adjusted to 135mA max

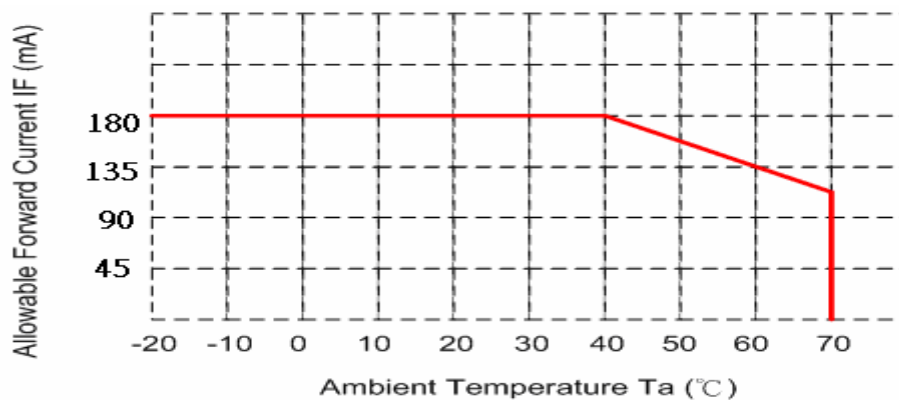

Preliminary

The contents of this document are confidential and must not be disclosed wholly or in part to any third part without the prior written consent of AMP DISPLAY

4. Pin Assignment (CN1)

Pin no	Symbol	Function
1	VDD	POWER SUPPLY:3.3V
2	VDD	POWER SUPPLY:3.3V
3	Gnd	Power Ground
4	Gnd	Power Ground
5	IN0-	Transmission Data of Pixels(R data input)
6	IN0+	Transmission Data of Pixels(R data input)
7	Gnd	Power Ground
8	1N1-	Transmission Data of Pixels 1(G data input)
9	1N1+	Transmission Data of Pixels 1(G data input)
10	Gnd	Power Ground
11	1N2-	Transmission Data of Pixels 2(B data input)
12	1N2+	Transmission Data of Pixels 2(B data input)
13	Gnd	Power Ground
14	CLK-	Sampling Clock
15	CLK+	Sampling Clock
16	Gnd	Power Ground
17	NC	No Connect
18	NC	No Connect
19	Gnd	Power Ground
20	Gnd	Power Ground

Block Diagram

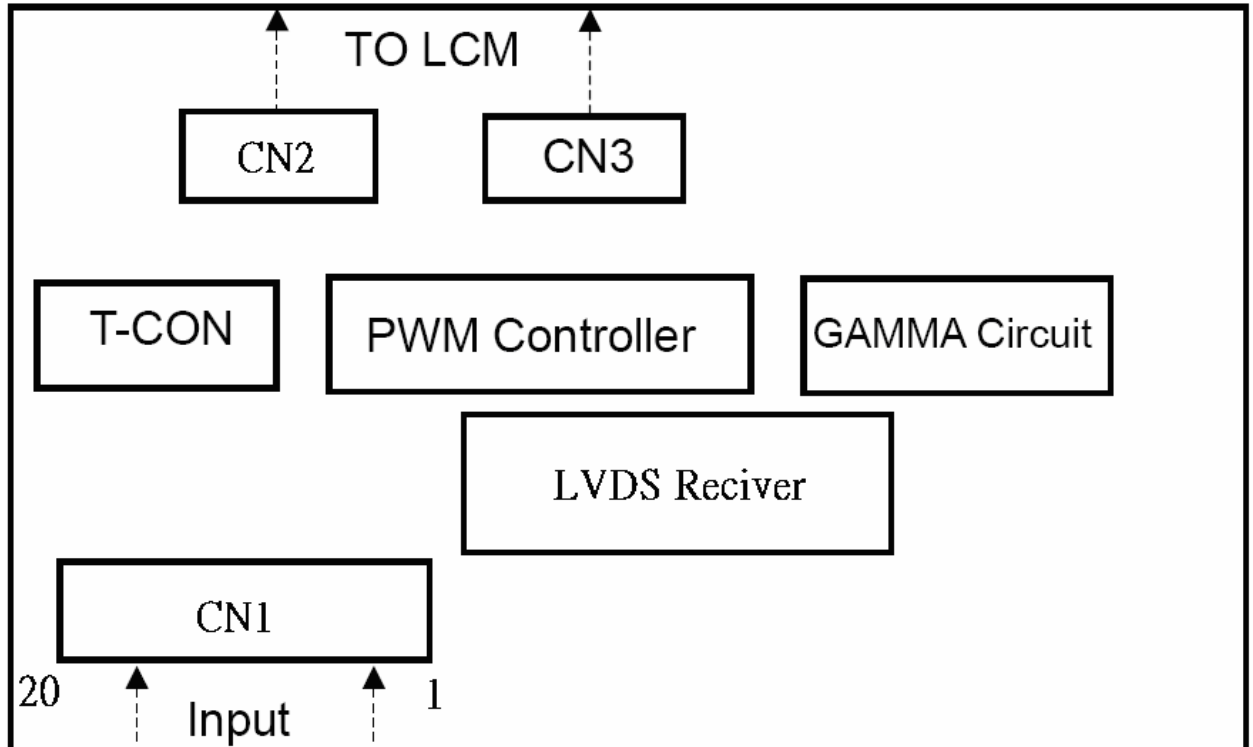

Preliminary

The contents of this document are confidential and must not be disclosed wholly or in part to any third part without the prior written consent of AMP DISPLAY

5. INPUT SIGNAL :

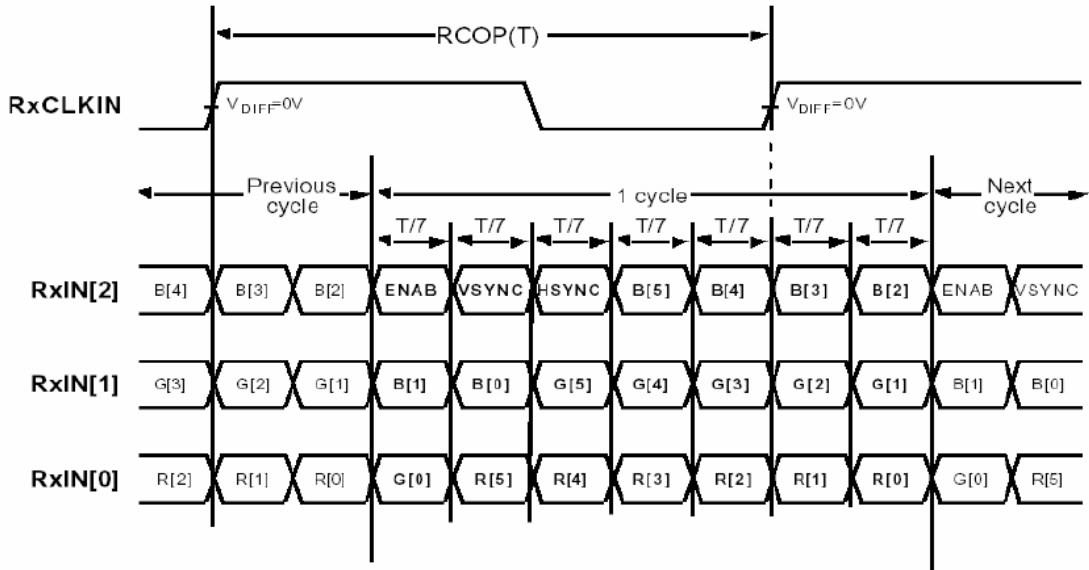

Note: R/G/B[7]s are MSBs and R/G/B[0]s are LSBs

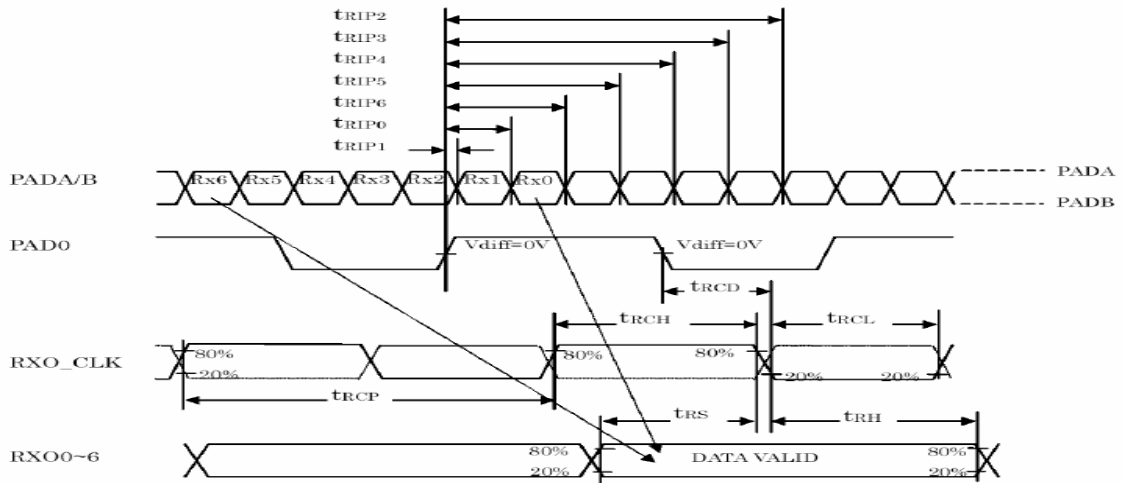

Preliminary

The contents of this document are confidential and must not be disclosed wholly or in part to any third part without the prior written consent of AMP DISPLAY

Phase Lock Loop Set Time

(Case1)

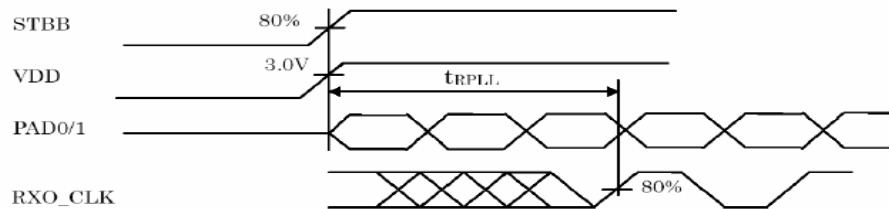

(Case2)

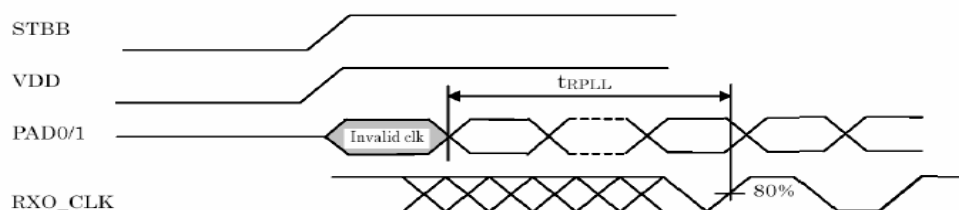

Switching Characteristics

< recommended operating condition (unless otherwise noted) >

Parameter	Symbol	min	typ	max	Unit
RXO_CLK Period	t_{rCP}	11.76	T	50	ns
RXO_CLK High Time	t_{rCH}	-	T/2	-	ns
RXO_CLK Low Time	t_{rCL}	-	T/2	-	ns
PAD0/1 to RXO_CLK Delay	t_{rCD}	-	3T/7	-	ns
Data Setup to RXO_CLK	t_{rS}	1.9	-	-	ns
Data Hold from RXO_CLK	t_{rH}	3.0	-	-	ns
Input Data Position 0 (T=11.76ns) (note1)	t_{rIP1}	-0.4	0	0.4	ns
Input Data Position 1 (T=11.76ns) (note1)	t_{rIP0}	T/7-0.4	T/7	T/7+0.4	ns
Input Data Position 2 (T=11.76ns) (note1)	t_{rIP6}	2T/7-0.4	2T/7	2T/7+0.4	ns
Input Data Position 3 (T=11.76ns) (note1)	t_{rIP5}	3T/7-0.4	3T/7	3T/7+0.4	ns
Input Data Position 4 (T=11.76ns) (note1)	t_{rIP4}	4T/7-0.4	4T/7	4T/7+0.4	ns
Input Data Position 5 (T=11.76ns) (note1)	t_{rIP3}	5T/7-0.4	5T/7	5T/7+0.4	ns
Input Data Position 6 (T=11.76ns) (note1)	t_{rIP2}	6T/7-0.4	6T/7	6T/7+0.4	ns
Phase Lock Loop Set	t_{rPLL}	-	-	10	ms

note1 : VDD=3.3V, Ta=25°C

Preliminary

The contents of this document are confidential and must not be disclosed wholly or in part to any third part without the prior written consent of AMP DISPLAY

6. OPTICAL CHARACTERISTICS

Item		Symbol	Conditon	Min.	Typ.	Max.	Unit	Note
Response Time		$T_r + T_f$	$\Theta = \Phi = 0^\circ$	-	25	-	ms	(1)
Contrast ratio		CR		400	500	-	-	(2)(3)
Viewing Angle	Vertical	Θ	$CR \geq 10$	100	120	-	Deg.	(5)
	Horizontal	Φ		120	140	-		
Luminance		L	$\Theta = \Phi = 0^\circ$	160	200	-	cd/m ²	(3)(4)
Luminance Uniformity		Y_U		70	75	-	%	(3)(4)
Color chromaticity	Red	R_x	$\Theta = \Phi = 0^\circ$	TBD	TBD	TBD	-	(3)
		R_y		TBD	TBD	TBD		
	Green	G_x		TBD	TBD	TBD		
		G_y		TBD	TBD	TBD		
	Blue	B_x		TBD	TBD	TBD		
		B_y		TBD	TBD	TBD		
	White	W_x		0.26	0.31	0.36		
		W_y		0.28	0.33	0.38		

NOTE :

- These items are measured by BM-5A(TOPCON) or CA-1000(MINOLTA) in the dark room (no ambient light)
- Test conditions : $V_{cc} = 3.3V$, $I_L = 20mA$ (Backlight current) , the ambient temperature is $25^\circ C$

(1) Definition of Response Time (White-Black)

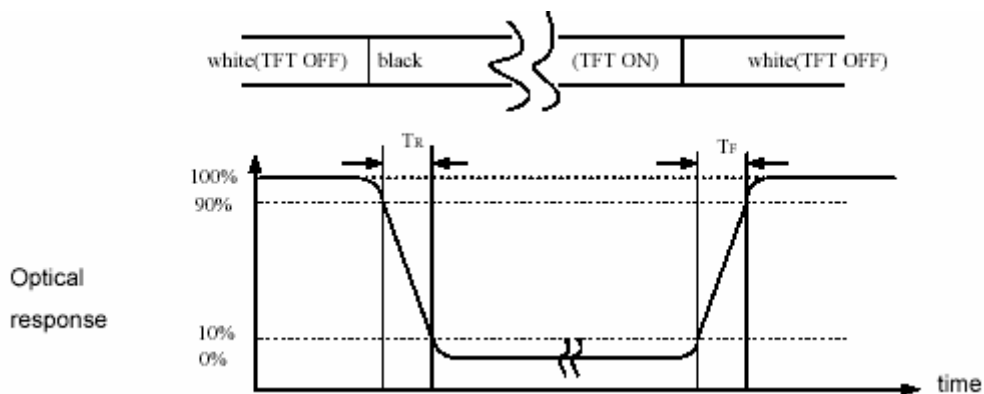

(2) Definition of Contrast Ratio

Measure contrast ratio on the below 9 points and take the average value
 Contrast ratio is calculated with the following formula :

Contrast Ratio(CR)=(White)Luminance of ON ÷ (Black)Luminance of OFF

Preliminary

The contents of this document are confidential and must not be disclosed wholly or in part to any third part without the prior written consent of AMP DISPLAY

(3) Definition of Luminance :

Measure white luminance on the same 9 points and take the average value

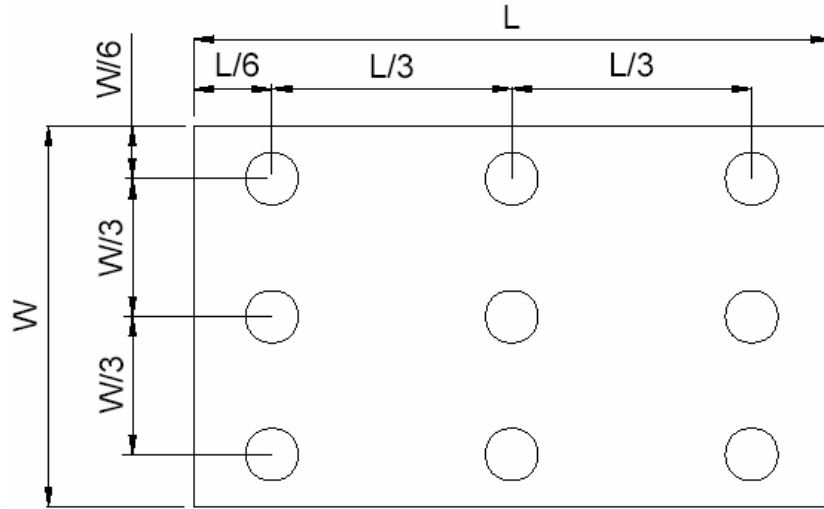

(4) Definition of Luminance Uniformity :

Measured Maximum luminance[L(MAX)] and Minimum luminance[L(MIN)] on the 9 points

Luminance Uniformity is calculated with the following formula :

$$Y_U = L(\text{MIN}) / L(\text{MAX})$$

(5) Definition of Viewing Angle

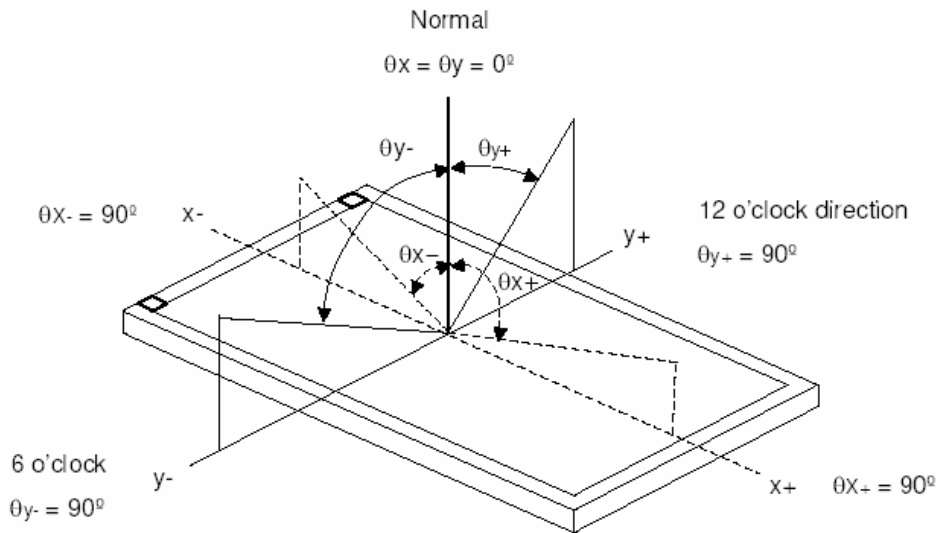

$$\Phi = (\Theta_{x+}) + (\Theta_{x-}) \quad \Theta = (\Theta_{y+}) + (\Theta_{y-})$$

Preliminary

The contents of this document are confidential and must not be disclosed wholly or in part to any third part without the prior written consent of AMP DISPLAY

7. Touch Panel Electrical Specifications

Parameter	Condition	Standard Value
Terminal Resistance	X Axis	300 ~ 1100 Ω
	Y Axis	150 ~ 650 Ω
Insulating Resistance	DC 25 V	More than 20MΩ
Linearity	--	±1.5 %
Notes life by Pen	Note a	100,000 times(min)
Input life by finger	Note b	1,000,000 times (min)

Note A .

Notes area for pen notes life test is 10 x 9 mm.

Size of word is 7.5 x 6.75

Shape of pen end : R0.8

Load : 250 g

Note B

By Silicon rubber tapping at same point

Shape of rubber end : R8

Load : 200g

Frequency : 5 Hz

Interface

No.	Symbol	Function
1	Y1	Touch Panel Bottom Signal in Y Axis
2	X1	Touch Panel Left Signal in X Axis
3	Y2	Touch Panel Top Signal in Y Axis
4	X2	Touch Panel Right Signal in X Axis

Preliminary

The contents of this document are confidential and must not be disclosed wholly or in part to any third part without the prior written consent of AMP DISPLAY

8. RELIABILITY TEST CONDITIONS

ITEM	CONDITIONS	NOTE
HIGH TEMPERATURE OPERATION	60°C , 240Hrs	
HIGH TEMPERATURE AND HIGH HUMIDITY OPERATION	40°C , 90%RH , 240Hrs	
HIGH TEMPERATURE STORAGE	70°C , 240Hrs	
LOW TEMPERATURE OPERATION	-10°C , 240Hrs	
LOW TEMPERATURE STORAGE	-30°C , 240Hrs	
THERMAL SHOCK	-30°C (30min) ~70°C (30min) For a total 100cycle	
MECHANICAL SHOCK	<ul style="list-style-type: none"> • 980m/S²(equal to 100G),6ms • (1/2 Sine wave),XYZ 	
VIBRATION	Frequency range : 10~55Hz Stroke : 1.5mm Sweep : 10Hz~55Hz~10Hz 2 hours for each direction of XYZ (6 hours for total)	
ESD	±2KV , Human Body Mode , 100Pf/1500Ω	

Preliminary

The contents of this document are confidential and must not be disclosed wholly or in part to any third part without the prior written consent of AMP DISPLAY

9. USE PRECAUTIONS

9-1 Handling precautions

- (1) The polarizing plate may break easily so be careful when handling it. Do not touch, press or rub it with a hard-material tool like tweezers.
- (2) Do not touch the polarizing plate surface with bare hands so as not to make it dirty. If the surface or other related part of the polarizing plate is dirty, soak a soft cotton cloth or chamois leather in benzene and wipe off with it. Do not use chemical liquids such as acetone, toluene and isopropyl alcohol. Failure to do so may bring chemical reaction phenomena and deteriorations.
- (3) Remove any spit or water immediately. If it is left for hours, the suffered part may deform or decolorize.
- (1) If the LCD element breaks and any LC stuff leaks, do not suck or lick it. Also if LC stuff is stuck on your skin or clothing, wash thoroughly with soap and water immediately.

9-2 Installing precautions

- (1) The PCB has many ICs that may be damaged easily by static electricity. To prevent breaking by static electricity from the human body and clothing, earth the human body properly using the high resistance and discharge static electricity during the operation. In this case, however, the resistance value should be approx. $1M\Omega$ and the resistance should be placed near the human body rather than the ground surface. When the indoor space is dry, static electricity may occur easily so be careful. We recommend the indoor space should be kept with humidity of 60% or more. When a soldering iron or other similar tool is used for assembly, be sure to earth it.
- (2) When installing the module and ICs, do not bend or twist them. Failure to do so may crack LC element and cause circuit failure.
- (3) To protect LC element, especially polarizing plate, use a transparent protective plate (e.g., acrylic plate, glass etc) for the product case.
- (4) Do not use an adhesive like a both-side adhesive tape to make LCD surface (polarizing plate) and product case stick together. Failure to do so may cause the polarizing plate to peel off

9-3 Storage precautions

- (1) Avoid a high temperature and humidity area. Keep the temperature between 0°C and 35°C and also the humidity under 60%.
- (2) Choose the dark spaces where the product is not exposed to direct sunlight or fluorescent light.
- (3) Store the products as they are put in the boxes provided from us or in the same conditions as we recommend.

Preliminary

The contents of this document are confidential and must not be disclosed wholly or in part to any third part without the prior written consent of AMP DISPLAY

9-4 Operating precautions

- (1) Do not boost the applied drive voltage abnormally. Failure to do so may break ICs. When applying power voltage, check the electrical features beforehand and be careful. Always turn off the power to the LC module controller before removing or inserting the LC module input connector. If the input connector is removed or inserted while the power is turned on, the LC module internal circuit may break.
- (2) The display response may be late if the operating temperature is under the normal standard, and the display may be out of order if it is above the normal standard. But this is not a failure; this will be restored if it is within the normal standard.
- (3) The LCD contrast varies depending on the visual angle, ambient temperature, power voltage etc. Obtain the optimum contrast by adjusting the LC drive voltage.
- (4) When carrying out the test, do not take the module out of the low-temperature space suddenly. Failure to do so will cause the module condensing, leading to malfunctions.
- (5) Make certain that each signal noise level is within the standard (L level: 0.2V_{dd} or less and H level: 0.8V_{dd} or more) even if the module has functioned properly. If it is beyond the standard, the module may often malfunction. In addition, always connect the module when making noise level measurements.
- (6) The CMOS ICs are incorporated in the module and the pull-up and pull-down function is not adopted for the input so avoid putting the input signal open while the power is ON.
- (7) The characteristic of the semiconductor element changes when it is exposed to light emissions, therefore ICs on the LCD may malfunction if they receive light emissions. To prevent these malfunctions, design and assemble ICs so that they are shielded from light emissions.
- (8) Crosstalk occurs because of characteristics of the LCD. In general, crosstalk occurs when the regularized display is maintained. Also, crosstalk is affected by the LC drive voltage. Design the contents of the display, considering crosstalk.

9-5 Other

- (1) Do not disassemble or take the LC module into pieces. The LC modules once disassembled or taken into pieces are not the guarantee articles.
- (2) The residual image may exist if the same display pattern is shown for hours. This residual image, however, disappears when another display pattern is shown or the drive is interrupted and left for a while. But this is not a problem on reliability.

Preliminary

The contents of this document are confidential and must not be disclosed wholly or in part to any third part without the prior written consent of AMP DISPLAY

10. OUTLINE DIMENSION

