



晶采光電科技股份有限公司
AMPIRE CO., LTD.

SPECIFICATIONS FOR LCD MODULE

CUSTOMER	
CUSTOMER PART NO.	
AMPIRE PART NO.	AM-800600K2TMQW-00H
APPROVED BY	
DATE	

Approved For Specifications

Approved For Specifications & Sample

AMPIRE CO., LTD.

2F., No.88, Sec. 1, Xintai 5th Rd., Xizhi Dist., New Taipei City 221, Taiwan (R.O.C.)

22181 新北市 汐止區 新台五路一段 88 號 2 樓

TEL:886-2-26967269 , FAX:886-2-26967196 or 26967270

APPROVED BY	CHECKED BY	ORGANIZED BY

RECORD OF REVISION

Revision Date	Page	Contents	Editor
2010/10/21	-	New Release	Kevin
2011/01/14	8	Add LED driver current	Kevin
	8	Modify LED current & voltage	Kevin
	12-14	Add new inspection standard	Kevin
2011/01/18	18	Replace with the New Drawing	Kevin
2011/02/10	3	Add Power Consumption	Kevin
2011/03/25	3	Add 6-bit Feature	Kevin
	9	Modify the Interface	Kevin
	10	Cancel the SEL 6/8 function	Kevin

1. INSTRUCTION

Ampire 10.4" Display Module is a color active matrix TFT-LCD that uses amorphous silicon TFT as a switching device . This model is composed of a TFT-LCD panel , a driving circuit , power supply circuit and a LED backlight system . This TFT-LCD has a high resolution SVGA(800(R.G.B) X 600) and can display up to 16.2M colors.

1-1. Features

- 10.4" (diagonal) configuration
- Input interface voltage : 3.3V
- LCD type : Transmissive , Normally White
- LVDS Interface
- 6-Bit Mode Only

1-2. Applications

- Portable TV

2. PHYSICAL SPECIFICATIONS

Item	Specifications	unit
Display resolution(dot)	800RGB (W) x 600(H)	dots
Active area	211.2 (W) x 158.4(H)	mm
View area	214.8(W) x 162.7(H)	mm
Pixel pitch	0.264 (W) x 0.264 (H)	mm
Color configuration	R.G.B -stripe	-
Overall dimension	243.0(W) x 185.6(H) x 7.2(D)	mm
Viewing direction	6 o'clock	-
Brightness	500	cd/m ²
Contrast ratio	500	-
Power Consumption	4394(Max)	mW
Display color	262K / 16.2M	color
Backlight unit	LED	-

3. ELECTRICAL CHARACTERISTICS

Item	Symbol	Min.	Typ.	Max.	Unit
TFT gate on voltage	VGH	16	18	20	V
TFT gate off voltage	VGL	-8	-7	-6	V
TFT common electrode voltage	VCOM	4	4.5	5	V

Note: (1) Vcom must be adjusted to optimize display quality :cross-talk, contrast ratio and etc.

(2) VGH is TFT gate operating voltage

(3) VGL is TFT gate operating voltage

(4) Environmental condition: 25±5°C

(5) Reference waveform for panel light on is as below : Gate width is 0.5ms.

4. OPTICAL CHARACTERISTICS

Item	Symbol	Conditions	Specifications			Unit	Note
			Min.	Typ.	Max.		
Transmittance	T%	Viewing normal angle $\theta_x = \theta_y = 0^\circ$	-	7.3	-	%	All left side data are based on CMO's following condition – 1.CG : NTSC 50% (CIE 1931) 2.LC : TN 3.Light Source : CMO 10.4" LED BLU 4.Film : Nitto Linear Polarizer NWF LNSW AGS1 / NWF LNSW 5.Machine : DMS 803
Contrast Ratio	CR		-	500	-		
Response Time (by Quick)	T_R		-	5	10	ms	
	T_F	-	15	20			
Viewing Angle	Hor.	θ_{x+}	60	70	-	deg.	
		θ_{x-}	60	70	-		
	Ver.	θ_{y+}	40	50	-		
		θ_{y-}	50	60	-		
Module Chromaticity	Red	X_R	0.570	0.600	0.630	Viewing normal angle $\theta_x = \theta_y = 0^\circ$	
		Y_R	0.314	0.344	0.374		
	Green	X_G	0.315	0.345	0.375		
		Y_G	0.549	0.579	0.609		
	Blue	X_B	0.125	0.155	0.185		
		Y_B	0.096	0.126	0.156		
	White	X_W	0.260	0.290	0.320		
		Y_W	0.288	0.318	0.348		
CF only Chromaticity	Red	X_R	0.593	0.623	0.653	Viewing normal angle $\theta_x = \theta_y = 0^\circ$	
		Y_R	0.298	0.328	0.358		
	Green	X_G	0.271	0.301	0.331		
		Y_G	0.540	0.570	0.600		
	Blue	X_B	0.113	0.143	0.173		
		Y_B	0.132	0.162	0.192		
	White	X_W	0.266	0.296	0.326		
		Y_W	0.304	0.334	0.364		

*Note (1) Definition of Contrast Ratio (CR):

The contrast ratio can be calculated by the following expression.

$$\text{Contrast Ratio (CR)} = L_{63} / L_0$$

L63: Luminance of gray level 63

L 0: Luminance of gray level 0

$$CR = CR (5)$$

CR (X) is corresponding to the Contrast Ratio of the point X at Figure in Note (5).

*Note (2) Definition of Response Time (T_R , T_F):

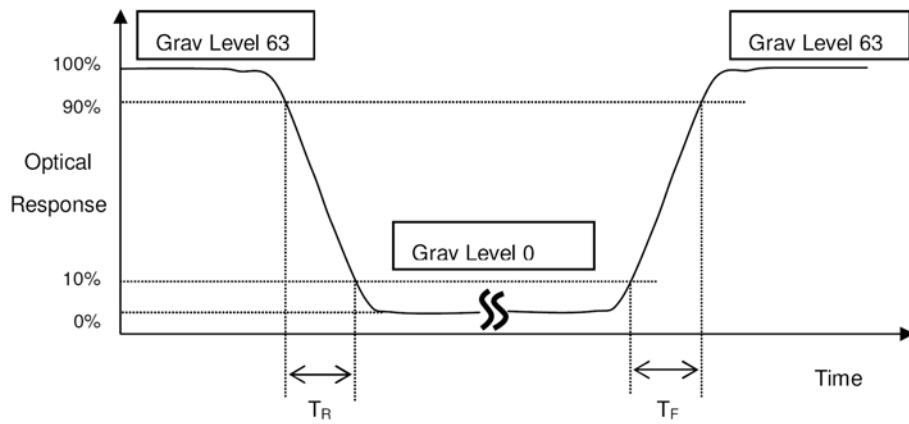

*Note(3) Definition of Viewing Angle

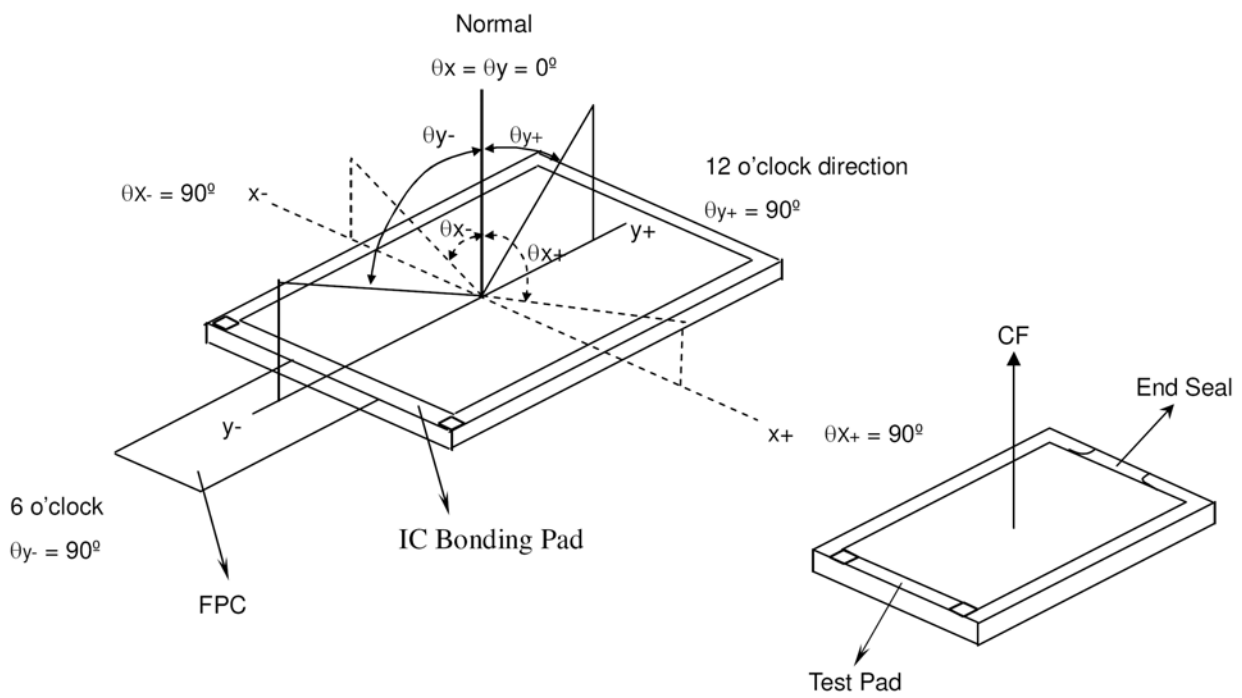

*Note (4) Measurement Set-Up:

The LCD module should be stabilized at a given temperature for 20 minutes to avoid abrupt temperature change during measuring. In order to stabilize the luminance, the measurement should be executed after lighting Backlight for 20 minutes in a windless room.

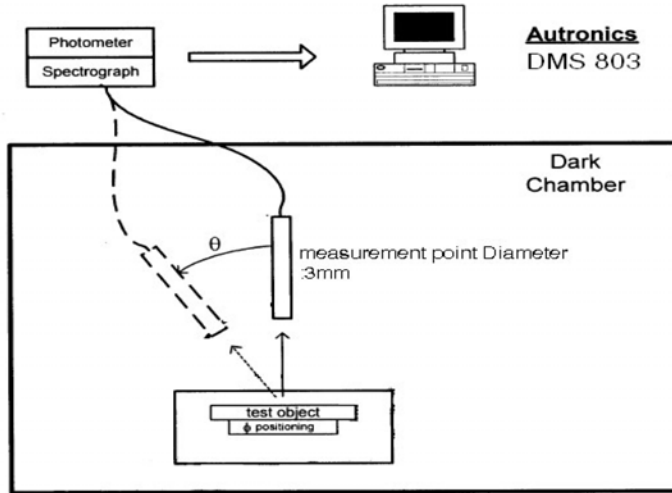

*Note (5)

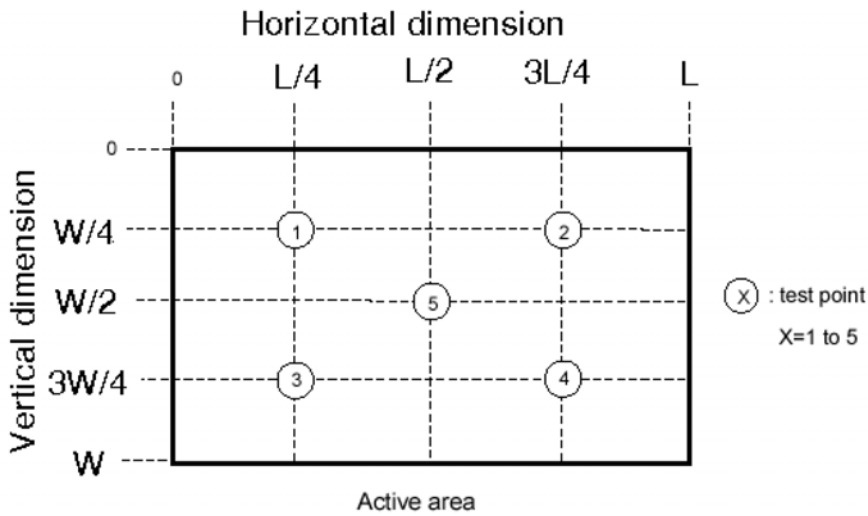

5. Backlight Driving Circuit

ITEM	SYMBOL	MIN	TYP	MAX	UNIT	NOTE
LED Voltage	VLED	-	19	-	V	
LED Current	ILED	-	140	-	mA	
LED life time	-	-	30,000	-	Hr	
LED DRIVER Power Current	ILED(VLED=19V)	-	170	-	mA	

PWM Dimming Control

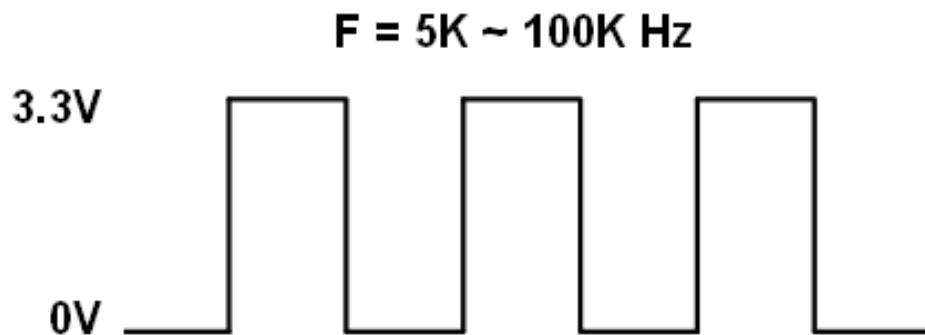
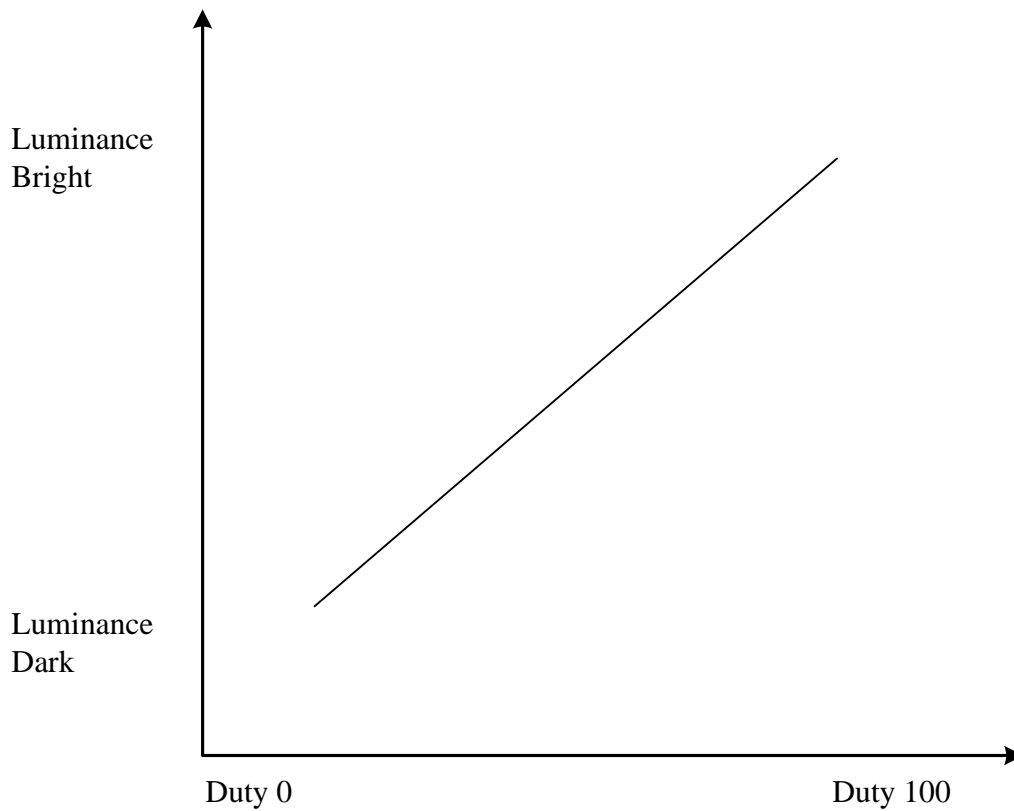

6. INTERFACE

CN1 : LCM PIN Definition

Pin no	Symbol	Function
1	VDD	Power Supply:3.3V
2	VDD	Power Supply:3.3V
3	GND	Power Ground
4	DPS	Reverse Scan Function [H:Enable ; L:Disable]
5	RxIN0-	Transmission Data of Pixels 0
6	RxIN0+	Transmission Data of Pixels 0
7	GND	Power Ground
8	RxIN1-	Transmission Data of Pixels 1
9	RxIN1+	Transmission Data of Pixels 1
10	GND	Power Ground
11	RxIN2-	Transmission Data of Pixels 2
12	RxIN2+	Transmission Data of Pixels 2
13	GND	Power Ground
14	RxCLKIN-	LVDS receiver signal clock
15	RxCLKIN+	LVDS receiver signal clock
16	GND	Power Ground
17	RxIN3-	Transmission Data of Pixels 3
18	RxIN3+	Transmission Data of Pixels 3
19	RSV	Reserved for internal test. Please treat it as NC
20	RSV	Reserved for internal test. Please treat it as NC

CN2 : Backlight adjustment PIN Definition

Pin no	Symbol	Function
1	VCC	Power Supply:12V
2	GND	Power Ground
3	ON/OFF	Function selection
4	Dimming	Adjust brightness
5	NA	No Connection

CN3 : Backlight Power Source PIN Definition

Pin no	Symbol	Function
1	A	Power 19V
2	K	Power Ground

7. Signal Characteristics

7.1 Pixel Format Image

Following figure shows the relationship between input signal and LCD pixel format.

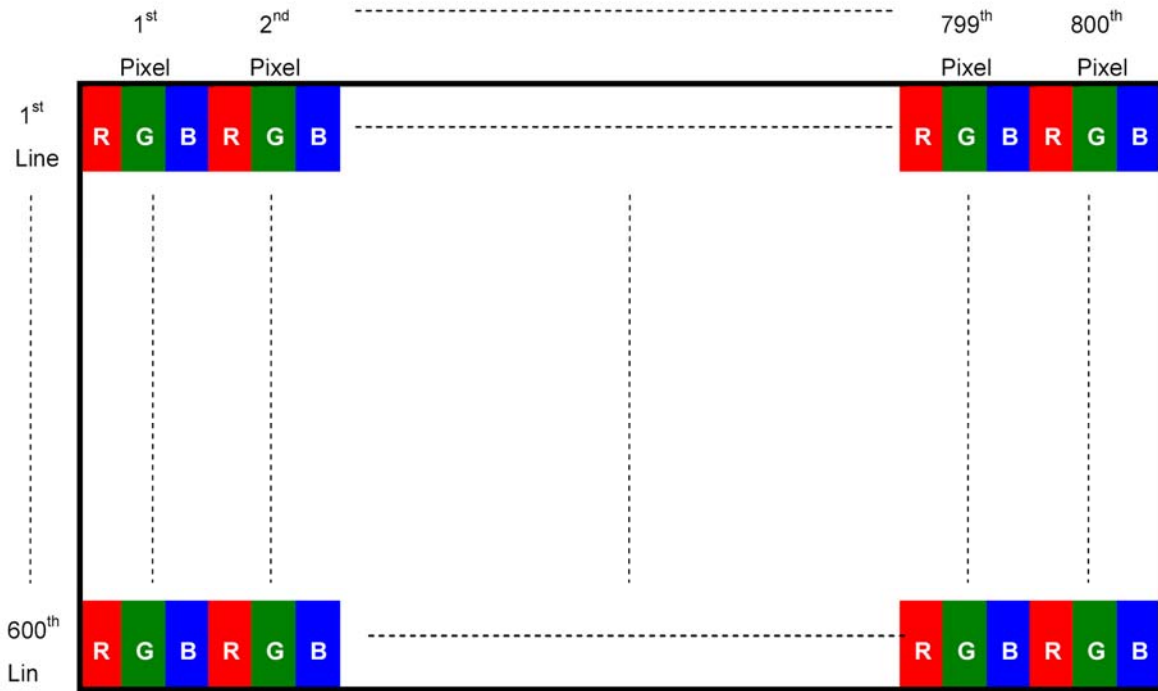

7.2 Scanning Direction

The following figures show the image seen from the front view. The arrow indicates the direction of scan.

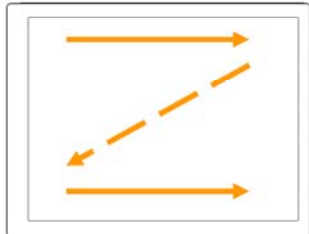

Fig. 1 Normal scan (Pin4, DPS = Low or NC)

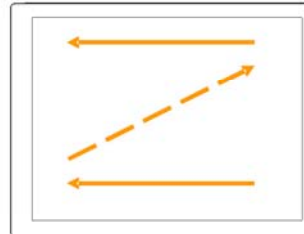

Fig. 2 Reverse scan (Pin4, DPS = High)

8 . INCOMING INSPECTION STANDARD

8-1. Scope

Specifications contain

8-1.1 Display Quality Evaluation

8-1.2 Mechanics Specification

8-2. Sampling Plan

Unless there is other agreement, the sampling plan for incoming inspection shall follow MIL-STD-105E LEVEL II.

8-2.1 Lot size: Quantity per shipment as one lot (different model as different lot).

8-2.2 Sampling type: Normal inspection, single sampling.

8-2.3 Sampling level: Level II.

8-2.4 AQL: Acceptable Quality Level

Major defect: AQL=0.65

Minor defect: AQL=1.0

8-3. Panel Inspection Condition

8-3.1 Environment:

Room Temperature: $25\pm 5^{\circ}\text{C}$.

Humidity: $65\pm 5\%$ RH.

Illumination: 300 ~ 700 Lux.

8-3.2 Inspection Distance:

35-40 cm

8-3.3 Inspection Angle:

The vision of inspector should be perpendicular to the surface of the Module.

8-3.4 Inspection time :

Perceptibility Test Time: 20 seconds max.

8-4. Display Quality

8-4.1 Function Related:

The function defects of line defect, abnormal display, and no display are considered Major defects.

8-4.2 Bright/Dark Dots:

Defect Type / Specification	G0 Grade	A Grade
Bright Dots	0	$N \leq 3$
Dark Dots	0	$N \leq 4$
Total Bright and Dark Dots	0	$N \leq 6$

[Note 1]

Judge defect dot and adjacent dot as following.

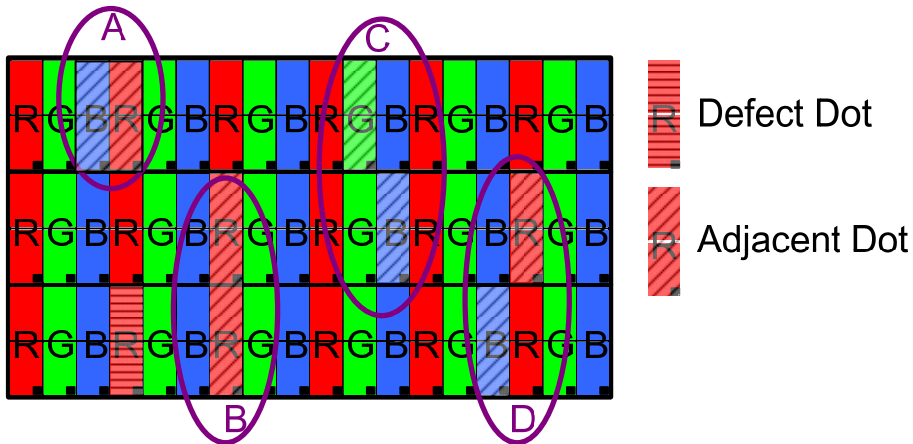

- (1) One pixel consists of 3 sub-pixels, including R,G, and B dot.(Sub-pixel = Dot)
- (2) The definition of dot: The size of a defective dot over 1/2 of whole dot is regarded as one defective dot.
- (3) Allow above (as A, B, C and D status) adjacent defect dots, including bright and dart adjacent dot. And they will be counted 2 defect dots in total quantity.
- (4) Defects on the Black Matrix, out of Display area, are not considered as a defect or counted.
- (5) There should be no distinct non-uniformity visible through 3% ND Filter within 2 sec inspection times.

8-4.3 Visual Inspection specifications:

Defect Type	Specification	Count(N)
Dot Shape (Particle、Scratch and Bubbles in display area)	D≤0.25mm	Ignored
	0.25mm < D ≤ 0.5mm	N ≤ 3
	D > 0.5mm	N=0
Line Shape (Particles、Scratch、Lint and Bubbles in display area)	W ≤ 0.07mm	Ignored
	0.07mm < W ≤ 0.1mm、L ≤ 5mm	N ≤ 3
	W > 0.1mm、L > 5mm	N=0

[Note 2] W : Width[mm], L : Length[mm], N : Number, ϕ : Average Diameter

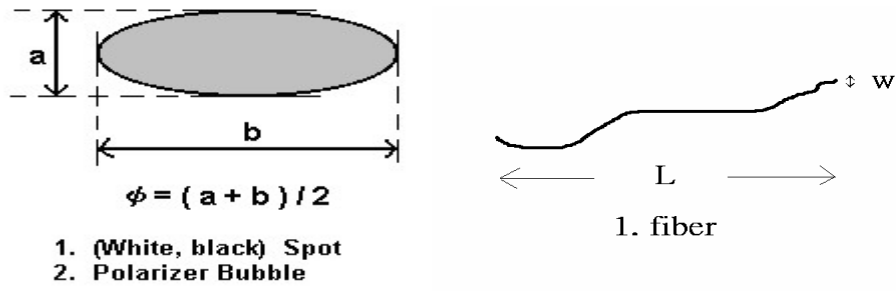

[Note 3] Bright dot is defined through 3% transmission ND Filter as following.

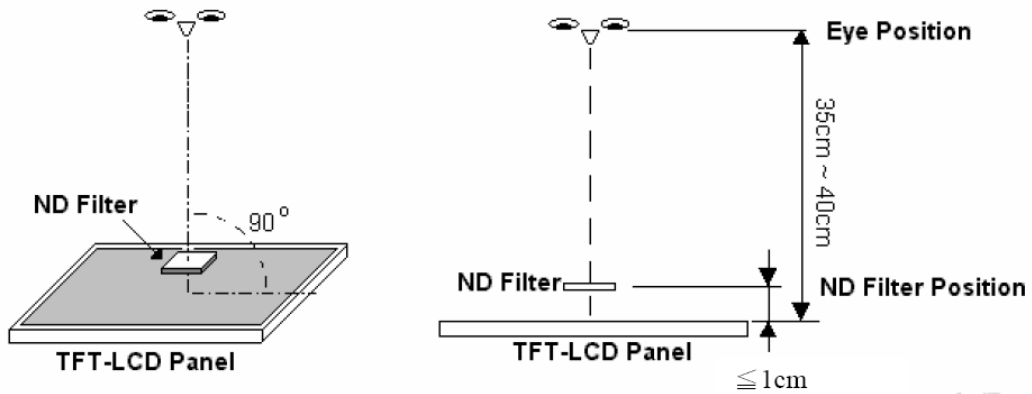

9. QUALITY AND RELIABILITY

Test Item	Test Conditions	Note
High Temperature Operation	70±3°C , t=240 hrs	
Low Temperature Operation	-20±3°C , t=240 hrs	
High Temperature Storage	80±3°C , t=240 hrs	1,2
Low Temperature Storage	-30±3°C , t=240 hrs	1,2
Thermal Shock Test	-20°C ~ 25°C ~ 70°C 30 m in. 5 min. 30 min. (1 cycle) Total 5 cycle	1,2
Humidity Test	60 °C, Humidity 90%, 240 hrs	1,2
Vibration Test (Packing)	Sweep frequency : 10 ~ 55 ~ 10 Hz/1min Amplitude : 0.75mm Test direction : X.Y.Z/3 axis Duration : 30min/each axis	2

Note 1 : Condensation of water is not permitted on the module.

Note 2 : The module should be inspected after 1 hour storage in normal conditions
(15-35°C , 45-65%RH).

Definitions of life end point :

- Current drain should be smaller than the specific value.
- Function of the module should be maintained.
- Appearance and display quality should not have degraded noticeably.
- Contrast ratio should be greater than 50% of the initial value.

10. USE PRECAUTIONS

10.1 Handling precautions

- 1) The polarizing plate may break easily so be careful when handling it. Do not touch, press or rub it with a hard-material tool like tweezers.
- 2) Do not touch the polarizing plate surface with bare hands so as not to make it dirty. If the surface or other related part of the polarizing plate is dirty, soak a soft cotton cloth or chamois leather in benzene and wipe off with it. Do not use chemical liquids such as acetone, toluene and isopropyl alcohol. Failure to do so may bring chemical reaction phenomena and deteriorations.
- 3) Remove any spit or water immediately. If it is left for hours, the suffered part may deform or decolorize.
- 4) If the LCD element breaks and any LC stuff leaks, do not suck or lick it. Also if LC stuff is stuck on your skin or clothing, wash thoroughly with soap and water immediately.

10.2 Installing precautions

- 1) The PCB has many ICs that may be damaged easily by static electricity. To prevent breaking by static electricity from the human body and clothing, earth the human body properly using the high resistance and discharge static electricity during the operation. In this case, however, the resistance value should be approx. $1M\Omega$ and the resistance should be placed near the human body rather than the ground surface. When the indoor space is dry, static electricity may occur easily so be careful. We recommend the indoor space should be kept with humidity of 60% or more. When a soldering iron or other similar tool is used for assembly, be sure to earth it.
- 2) When installing the module and ICs, do not bend or twist them. Failure to do so may crack LC element and cause circuit failure.
- 3) To protect LC element, especially polarizing plate, use a transparent protective plate (e.g., acrylic plate, glass etc) for the product case.
- 4) Do not use an adhesive like a both-side adhesive tape to make LCD surface (polarizing plate) and product case stick together. Failure to do so may cause the polarizing plate to peel off.

10.3 Storage precautions

- 1) Avoid a high temperature and humidity area. Keep the temperature between 0°C and 35°C and also the humidity under 60%.
- 2) Choose the dark spaces where the product is not exposed to direct sunlight or fluorescent light.
- 3) Store the products as they are put in the boxes provided from us or in the same conditions as we recommend.

10.4 Operating precautions

- 1) Do not boost the applied drive voltage abnormally. Failure to do so may break ICs. When applying power voltage, check the electrical features beforehand and be careful. Always turn off the power to the LC module controller before removing or inserting the LC module input connector. If the input connector is removed or inserted while the power is turned on, the LC module internal circuit may break.
- 2) The display response may be late if the operating temperature is under the normal standard, and the display may be out of order if it is above the normal standard. But this is not a failure; this will be restored if it is within the normal standard.
- 3) The LCD contrast varies depending on the visual angle, ambient temperature, power voltage etc. Obtain the optimum contrast by adjusting the LC drive voltage.
- 4) When carrying out the test, do not take the module out of the low-temperature space suddenly. Failure to do so will cause the module condensing, leading to malfunctions.
- 5) Make certain that each signal noise level is within the standard (L level: 0.2V_{dd} or less and H level: 0.8V_{dd} or more) even if the module has functioned properly. If it is beyond the standard, the module may often malfunction. In addition, always connect the module when making noise level measurements.
- 6) The CMOS ICs are incorporated in the module and the pull-up and pull-down function is not adopted for the input so avoid putting the input signal open while the power is ON.
- 7) The characteristic of the semiconductor element changes when it is exposed to light emissions, therefore ICs on the LCD may malfunction if they receive light emissions. To prevent these malfunctions, design and assemble ICs so that they are shielded from light emissions.
- 8) Crosstalk occurs because of characteristics of the LCD. In general, crosstalk occurs when the regularized display is maintained. Also, crosstalk is affected by the LC drive voltage. Design the contents of the display, considering crosstalk.

10.5 Other

- 1) Do not disassemble or take the LC module into pieces. The LC modules once disassembled or taken into pieces are not the guarantee articles.
- 2) The residual image may exist if the same display pattern is shown for hours. This residual image, however, disappears when another display pattern is shown or the drive is interrupted and left for a while. But this is not a problem on reliability.
- 3) AMIPRE will provide one year warranty for all products and three months warrantee for all repairing products.

11. OUTLINE DIMENSION

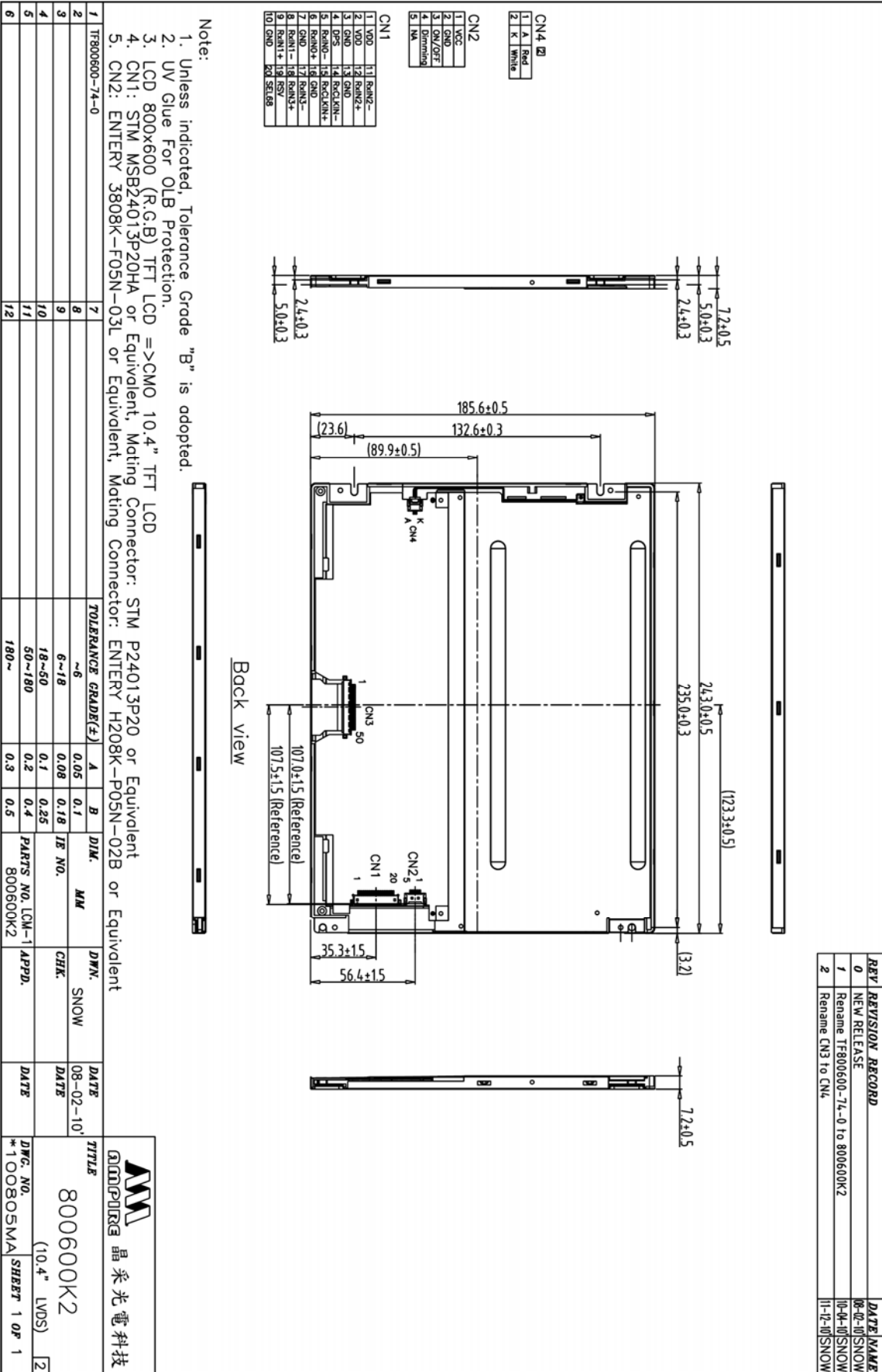

REV	REVISION RECORD	DATE	NAME
0	NEW RELEASE	09-21-10	SNOW
1	Rename TF800600-74-0 to 800600K2	10-04-10	SNOW

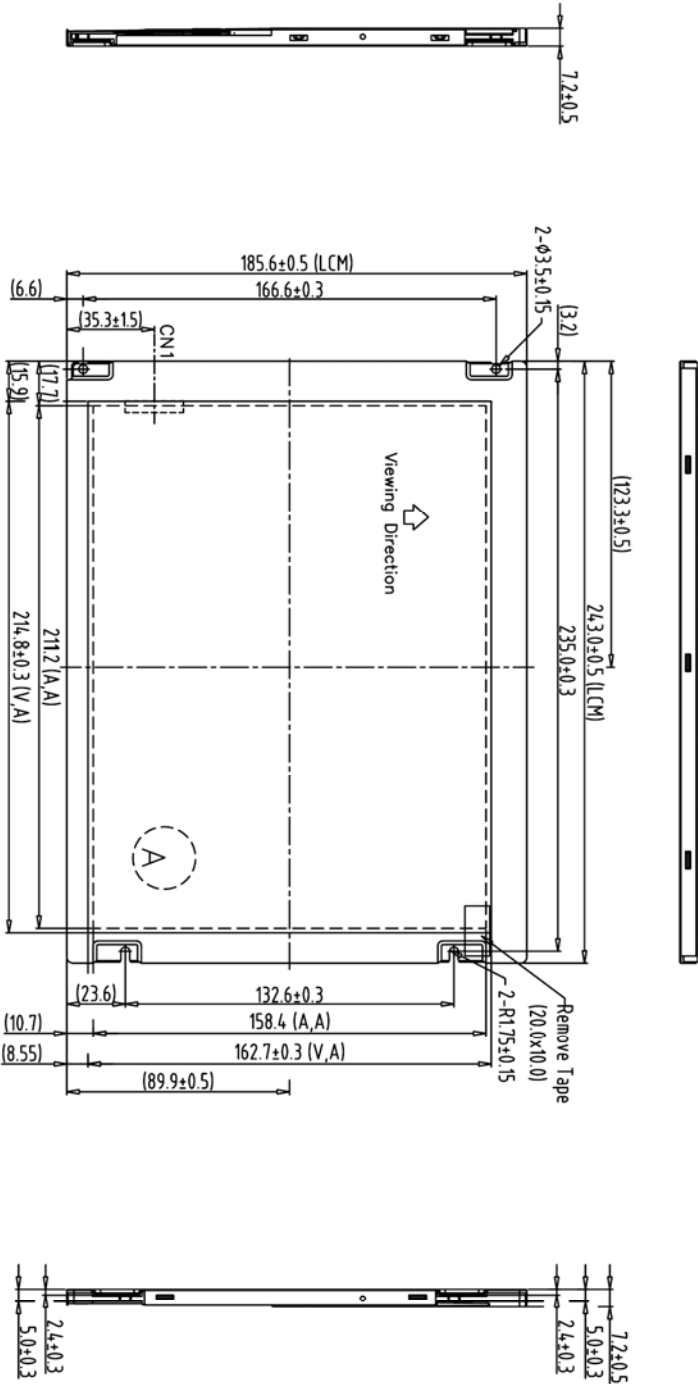
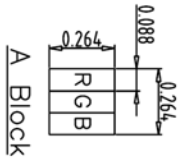

CN3

1	A	Red
2	K	White

CN2

1	VCC
2	GND
3	ON/OFF
4	Dimming
5	NA

CN1

1	VDD	11	RIN2-
2	VDD	12	RIN2+
3	GND	13	GND
4	DPS	14	RQCLIN-
5	RIN0-	15	RQCLIN+
6	RIN0+	16	GND
7	GND	17	RIN3+
8	RIN1-	18	RIN3+
9	RIN1+	19	RSV
10	GND	20	SEL08

Note:
 1. Unless indicated, Tolerance Grade "B" is adopted.
 2. UV Glue For OLB Protection.

- LCD 800x600 (R,G,B) TFT LCD =>CMO 10.4" TFT LCD
- CN1: STM MSB24013P20HA or Equivalent, Mating Connector: STM P24013P20 or Equivalent
- CN2: ENTERY 3808K-F05N-03L or Equivalent, Mating Connector: ENTERY H208K-P05N-02B or Equivalent

ITEM NO.	DESCRIPTION	QTY	TOLERANCE	GRADE(±)	A	B	DIM.	MM	DWN.	SNOW	DATE	TITLE
1	TF800600-74-0	7			~6	0.05	0.1				09-21-10	晶光电科技
2		8			6~18	0.08	0.18					800600K2
3		9			18~50	0.1	0.25		CHK.			(10.4" LVDS)
4		10			50~180	0.2	0.4		APPD.			SHEET 1 OF 1
5		11			180~	0.3	0.5					
6		12										

晶光电科技
 800600K2
 (10.4" LVDS)