

AM1S-N Series

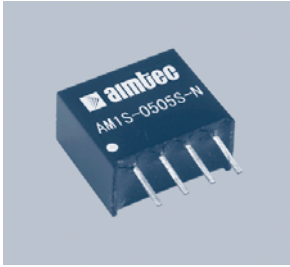

1 watt dc-dc converters

- 4PIN SIP PACKAGE
- LOW RIPPLE & NOISE
- HIGH EFFICIENCY UP TO 81%
- UL94-VO PACKAGE
- INPUT/OUTPUT ISOLATION: 1000 & 3000VDC
- OPERATING TEMPERATURE: -40°C ... +85°C
- PIN-COMPATIBLE WITH MULTIPLE MANUFACTURERS

GENERAL DESCRIPTION

Our AM1S-N series is a family of cost effective 1W single output isolated DC/DC converters. These converters achieve low cost and ultra-miniature SIP4 pin size without compromising performance and reliability.

Twenty models operate from input voltages of 5, 12 & 24VDC; producing output voltage levels of 5, 9, 12 & 15VDC. Full SMD-design and a 100 % production test of parameters ensures a high reliability in this product.

ELECTRICAL SPECIFICATIONS

Specifications typical at +25°C, nominal input voltage, rated output current unless otherwise specified.

Input Specifications:

Voltage range	±10%
Filter	Capacitor

Isolation Specifications:

Rated voltage (60 sec)	1000 & 3000VDC
Resistance	> 1000MOhm
Capacitance	60pF, typ.

Output Specifications:

Voltage accuracy	see tolerance envelope graph
Ripple & noise (at 20MHz BW)	75mVp-p, typ
Short circuit protection	1 sec
Line voltage regulation	±1.2% / 1.0% of Vin
Load voltage regulation	10% max, load=10~100%
Temperature coefficient	±0.03%/°C, max.

General Specifications:

Efficiency	78% to 81%
Switching frequency	150KHz, typ. 100% load

Environmental Specifications:

Operating temperature (ambient)	-40°C ... +85°C
Storage temperature	-55°C ... +125°C
Case Temperature	+90°C, max.
Derating	None required
Humidity (non-condensing)	Up to 90%
Cooling	Free-air Convection

Physical Specifications:

Dimensions	11.7x6.0x10.0mm 0.46x0.24x0.4inches
Weight	1.8g
Case material	Plastic UL94-VO

MTBF: > 1,000,000 hrs (MIL-HDBK-217F, Ground Benign, t=+25°C)

Specifications are subject to change without notification

OUTLINE DIMENSIONS & PIN CONNECTIONS

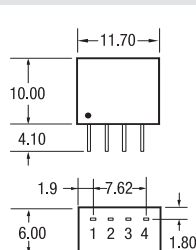

Side View

Bottom View

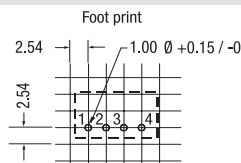

Note: All Pins on a 2.54mm pitch;
All Pin diameters are 0.50 mm;
all dimensions in mm.

Pin	1000 & 3000VDC
	Single
1	-V Input
2	+V Input
3	-V Output
4	+V Output

AM1S-N Series

MODELS Single output

Models		Input Voltage	Output Voltage	Output Current max.
Isolation 1000VDC	Isolation 3000VDC			
AM1S-0505S-N	AM1S-0505SH30-N	5V±10%	5VDC	200mA
AM1S-0509S-N	AM1S-0509SH30-N		9VDC	110mA
AM1S-0512S-N	AM1S-0512SH30-N		12VDC	83mA
AM1S-0515S-N	AM1S-0515SH30-N		15VDC	67mA
AM1S-1205S-N	AM1S-1205SH30-N	12V±10%	5VDC	200mA
AM1S-1209S-N	AM1S-1209SH30-N		9VDC	110mA
AM1S-1212S-N	AM1S-1212SH30-N		12VDC	83mA
AM1S-1215S-N	AM1S-1215SH30-N		15VDC	67mA
AM1S-2405S-N		24V±10%	5VDC	200mA
AM1S-2409S-N			9VDC	110mA
AM1S-2412S-N			12VDC	83mA
AM1S-2415S-N			15VDC	67mA

No Load power consumption 10% of nominal power (typical)

TYPICAL CHARACTERISTICS

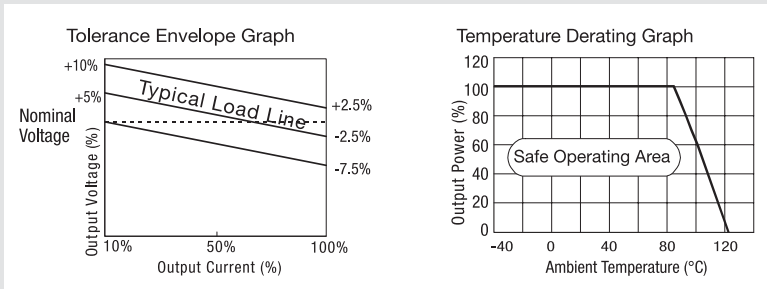

APPLICATION NOTE

Filtering

In some circuits which are sensitive to noise and ripple, a filtering capacitor may be added to the DC/DC output end and input end to reduce the noise and ripple. However, the capacitance of the output filter capacitor must be proper. If the capacitance is too big, a startup problem might arise. For every channel of output, provided the safe and reliable operation is ensured, the greatest capacitance of its filter capacitor sees the external capacitor table. To get an extremely low ripple, an LC filtering network may be connected to the input and output ends of the DC/DC converter, which may produce a more significant filtering effect. It should also be noted that the inductance and the frequency of the LC filtering network should be staggered with the DC/DC frequency to avoid mutual interference (see figure 1).

Requirement On Output Load

To ensure this module can operate efficiently and reliably, a minimum load is specified for this kind of DC/DC converter in addition to a maximum load (namely full load). During operation, make sure the specified range of input voltage is not exceeded, the minimum output load is not less than 10% of the full load, and that this product should never be operated under no load! If the actual output power is very small, please connect a resistor with proper resistance at the output end in parallel to increase the load.

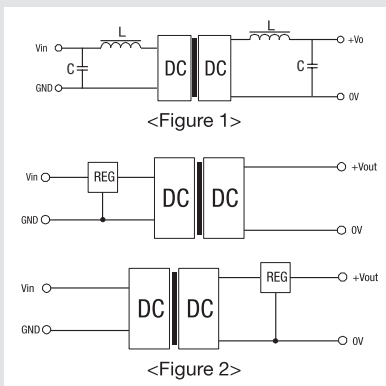

Overload Protection

Under normal operating conditions, the output circuit of these products has no protection against over-current and short-circuits. The simplest method is to connect a self-recovery fuse in series at the input end or add a circuit breaker to the circuit.

Output Voltage Regulation and Over-voltage Protection Circuit

The simplest device for output voltage regulation, over-voltage and over-current protection is a linear voltage regulator with overheat protection that is connected to the input or output end in series (see Figure 2).

External Capacitor Table

Vin	External Capacitor	Vout	External Capacitor
5VDC	4.7uF	5VDC	10uF
12VDC	2.2uF	9VDC	4.7uF
24VDC	1uF	12VDC	2.2uF
-	-	15VDC	1uF