

SINGLE PHASE FULL WAVE DIRECT PWM MOTOR DRIVER**AM4962**

General Description

The AM4962 is a full wave driver IC with direct PWM control function. It is used for single phase motor and is capable of speed control by PWM pulse.

The AM4962 is available in HTSSOP-14 and SSOP-16 packages.

Features

- The Motor Speed is Controlled by PWM Pulse Directly
- Built-in Triangle Wave Circuit Without Extra Oscillation Capacitor
- Built-in Hall Bias Circuit
- Built-in Minimal Speed Setup Circuit
- Slope K^* Adjustable
- Rotation Speed Indication (FG)
- Rotation or Lock State Indication (RD)
- Built-in Thermal Shutdown Circuit
- Lock Protection and Auto-restart
- Output Current Limit

* Slope K is the slope of output PWM duty vs. input PWM duty

Applications

- CPU Cooler Fan in PC
- Brushless DC Motor Driver

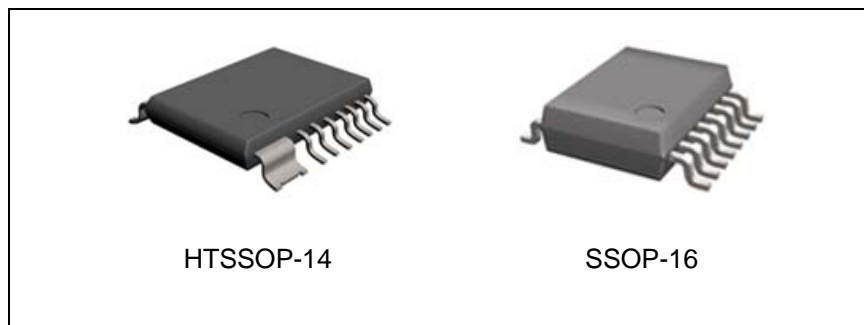

Figure 1. Package Types of AM4962

Pin Configuration

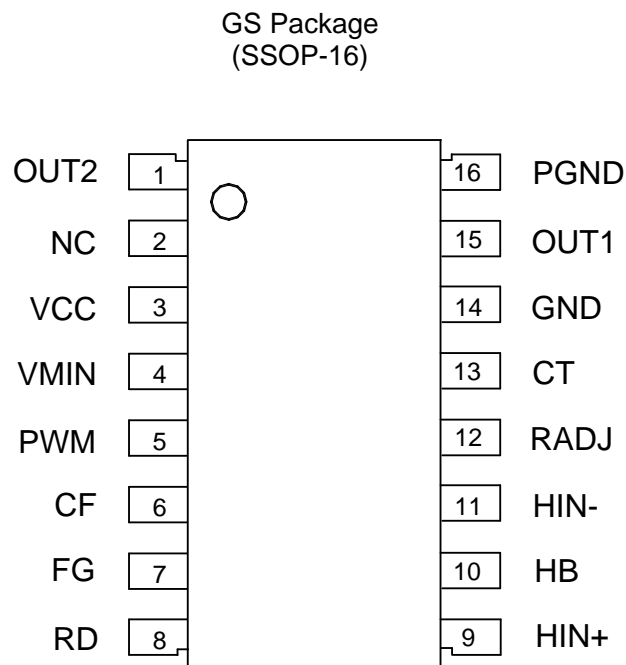
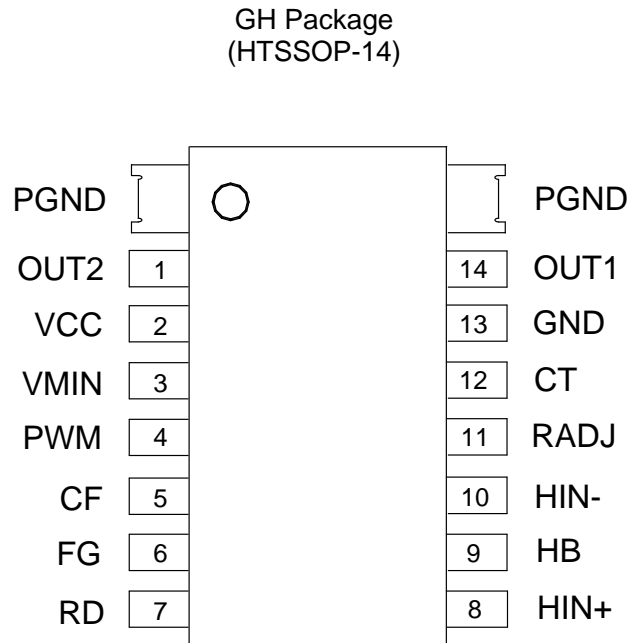
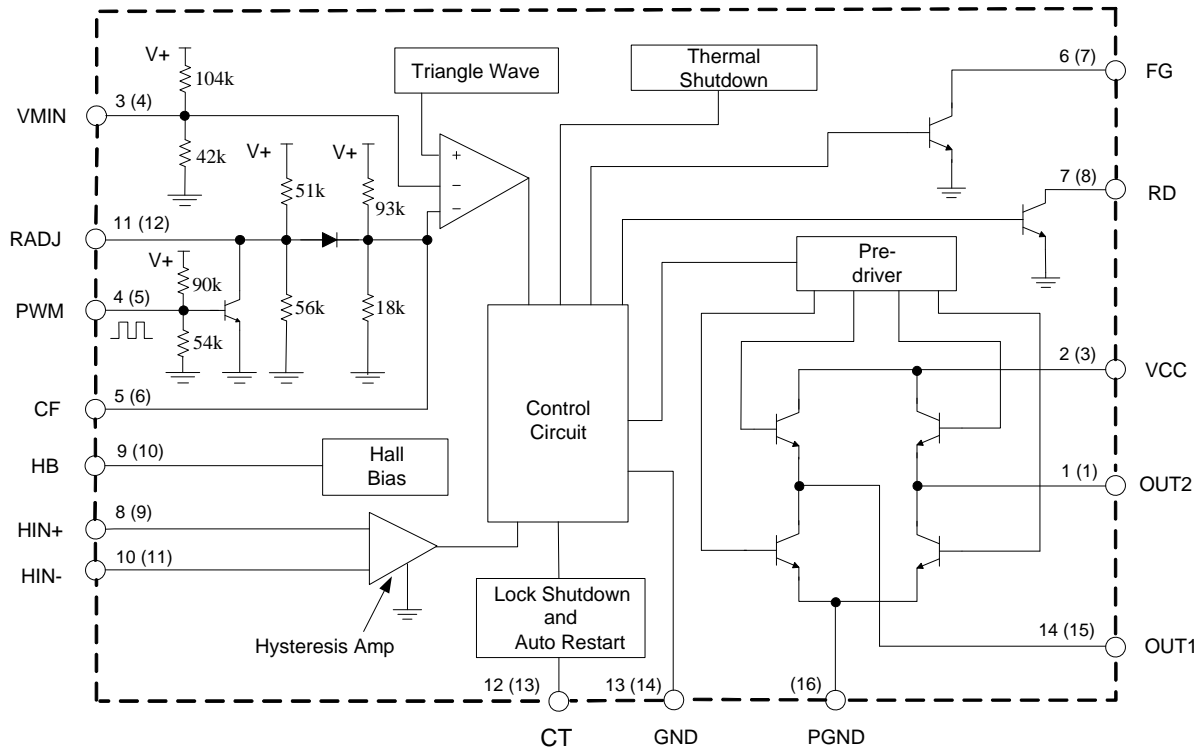

Figure 2. Pin Configuration of AM4962 (Top View)

**SINGLE PHASE FULL WAVE DIRECT PWM MOTOR DRIVER****AM4962****Pin Description**

Pin Number		Pin Name	Function
HTSSOP-14	SSOP-16		
1	1	OUT2	Driver output 2
	2	NC	No connection
2	3	VCC	Power supply
3	4	VMIN	Minimum duty setting
4	5	PWM	PWM pulse Input
5	6	CF	PWM filter capacitor
6	7	FG	Rotation speed indicator
7	8	RD	Rotation/lock state indicator
8	9	HIN+	Hall sensor input +
9	10	HB	Hall sensor bias regulator
10	11	HIN-	Hall sensor input -
11	12	RADJ	Slope K adjustable terminal
12	13	CT	Lock and rotation setting capacitor terminal
13	14	GND	Ground for control circuit
14	15	OUT1	Driver output 1
	16	PGND	Power ground

Functional Block Diagram



A (B)
 A HTSSOP-14
 B SSOP-16

Figure 3. Functional Block Diagram of AM4962

Truth Table (Note 1)

Items	IN-	IN+	CF	CT	OUT1	OUT2	FG	Mode
1	H	L	L	L	H	L	L	Rotation
2	L	H			L	H	Off	PWM off
3	H	L	H		Off	L	L	Rotation Recirculate
4	L	H			L	Off	Off	PWM off
5	H	L	L	H	H	Off	L	Lock Protection
6	L	H			Off	H	Off	

Note 1: $V_{CF(H)}=5V$, $V_{CF(L)}=1V$, $V_{CT(H)}=5V$, $V_{CT(L)}=0$

SINGLE PHASE FULL WAVE DIRECT PWM MOTOR DRIVER

AM4962

Ordering Information

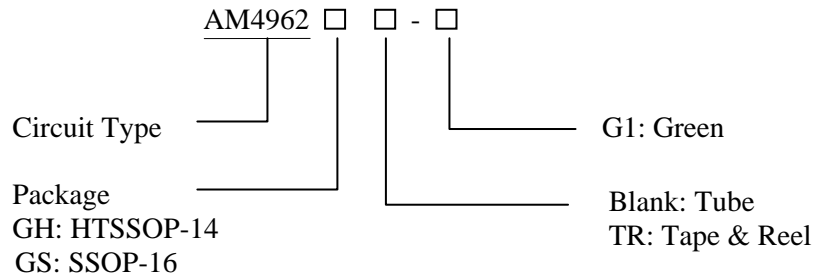

Package	Temperature Range	Part Number	Marking ID	Packing Type
HTSSOP-14	-30 to 90°C	AM4962GH-G1	AM4962GH-G1	Tube
		AM4962GHTR-G1	AM4962GH-G1	Tape & Reel
SSOP-16		AM4962GS-G1	AM4962GS-G1	Tube
		AM4962GSTR-G1	AM4962GS-G1	Tape & Reel

BCD Semiconductor's Pb-free products, as designated with "G1" suffix in the part number, are RoHS compliant and green.

**SINGLE PHASE FULL WAVE DIRECT PWM MOTOR DRIVER****AM4962****Absolute Maximum Ratings (Note 2)**

Parameter	Symbol	Value		Unit
Supply Voltage	V_{CC}	18		V
Output Current	I_{OUT}	1.0		A
Output Voltage	V_{OUT}	18		V
HB Output Current	I_{HB}	10		mA
RD Output Voltage	V_{RD}	18		V
FG Output Voltage	V_{FG}	18		V
RD Output Current	I_{RD}	10		mA
FG Output Current	I_{FG}	10		mA
Power Dissipation	P_D	SSOP-16	0.8	W
		HTSSOP-14	1.1	W
Storage Temperature Range	T_{STG}	-55 to 150		°C
Thermal Resistance (Junction to Ambient)	θ_{JA}	SSOP-16	156	°C/W
		HTSSOP-14	114	
ESD (Human Body Model)	ESD	2000		V
ESD (Machine Model)	ESD	250		V

Note 2: Stresses greater than those listed under “Absolute Maximum Ratings” may cause permanent damage to the device. These are stress ratings only, and functional operation of the device at these or any other conditions beyond those indicated under “Recommended Operating Conditions” is not implied. Exposure to “Absolute Maximum Ratings” for extended periods may affect device reliability.

Recommended Operating Conditions

Parameter	Symbol	Min	Typ	Max	Unit
Supply Voltage	V_{CC}	3.5	12	16	V
Hall Input Voltage + (Note 3)	V_{IN+}	0.2		3	V
Hall Input Voltage - (Note 3)	V_{IN-}	0.2		3	V
PWM High Level Voltage	V_{PWM}			$V_{CC}-1$	V
Ambient Temperature	T_A	-30		90	°C

Note 3: Hall input voltage range includes the amplitude of signal.

**SINGLE PHASE FULL WAVE DIRECT PWM MOTOR DRIVER****AM4962****Electrical Characteristics**(V_{CC}=12V, T_A=25°C, unless otherwise specified.)

Parameter	Symbol	Conditions	Min	Typ	Max	Unit
Quiescent Current	I _{Q1}	V _{CT} =0	10.18	15	18.76	mA
	I _{Q2}	V _{CT} =5V	5.38	8	10.55	
Output Saturation Voltage at High Side	V _{SATH}	I _{SOURCE} =200mA		1.0	1.17	V
Output Saturation Voltage at Low Side	V _{SATL}	I _{SINK} =200mA		0.2	0.3	V
CPWM Frequency	f _{OSC}		18	25	32	kHz
CF High Level Voltage	V _{CFH}	V _{PWM} =0	3.2	3.6	3.75	V
CF Low Level Voltage	V _{CFL}	V _{PWM} =5	1.83	1.95	2.15	V
V _{MIN} Voltage	V _{MIN}		3.4	3.7	4.0	V
RADJ Pin Voltage	V _{ADJ}	V _{PWM} =0	3.6	3.8	4.4	V
Hall Input Hysteresis	V _{HYS}			±10	±20	mV
Hall Bias Voltage	V _{HB}	I _{HB} =5mA	1.1	1.25	1.4	V
CT High Level Voltage	V _{CTH}		3.55	3.7	3.88	V
CT Low Level Voltage	V _{CTL}		1.55	1.7	1.85	V
CT Charge Current	I _{CHG}		1.5	2	2.85	μA
CT Discharge Current	I _{DHG}		0.14	0.2	0.285	μA
CT Charge and Discharge Ratio	R _{CD}	I _{CHG} /I _{DHG}	8.5	10	14.5	
FG Output Low Level Voltage	V _{FGL}	I _{FG} =5mA		0.2	0.3	V
FG Leakage Current	I _{LFG}	V _{FG} =12V			30	μA
RD Output Low Level Voltage	V _{RDL}	I _{RD} =5mA		0.2	0.3	V
RD Leakage Current	I _{LRD}	V _{RD} =12V			30	μA

Typical Performance Characteristics

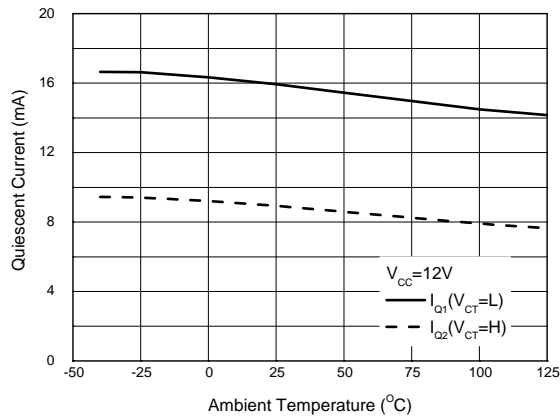

Figure 4. Quiescent Current vs. Ambient Temperature

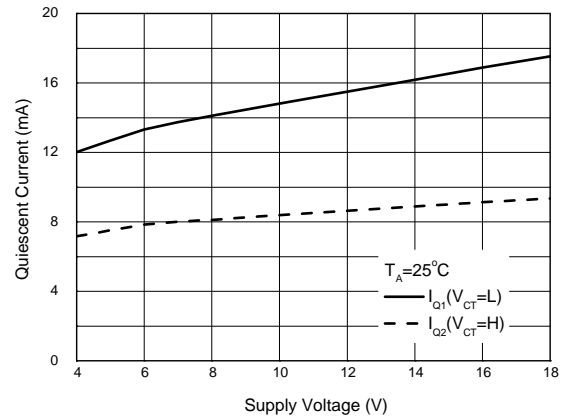

Figure 5. Quiescent Current vs. Supply Voltage

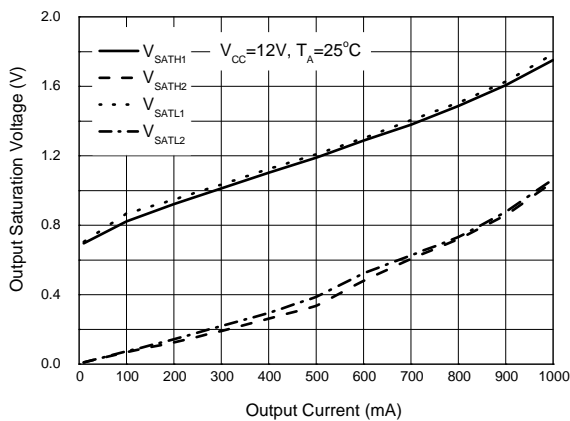

Figure 6. Output Saturation Voltage vs. Output Current

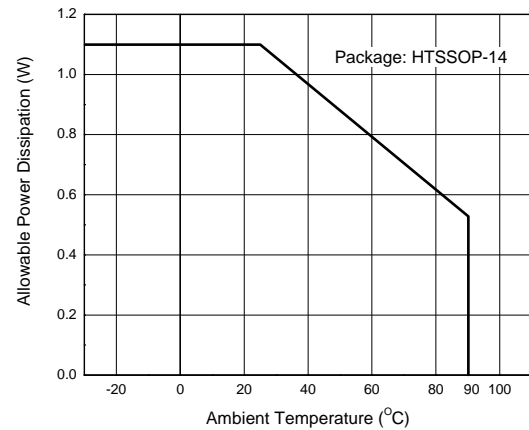

Figure 7. Power Dissipation vs. Ambient Temperature

Typical Performance Characteristics (Continued)

Figure 8. Power Dissipation vs. Ambient Temperature

Operating Diagram

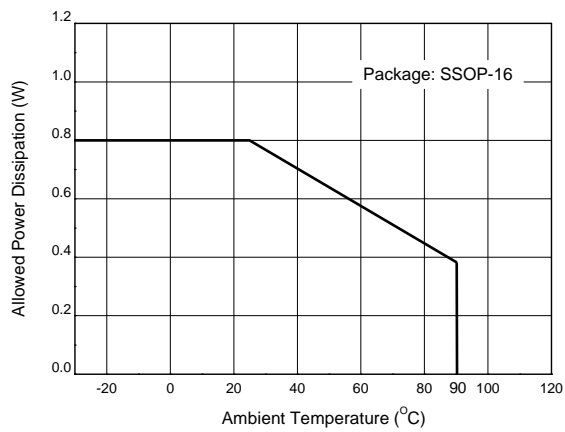
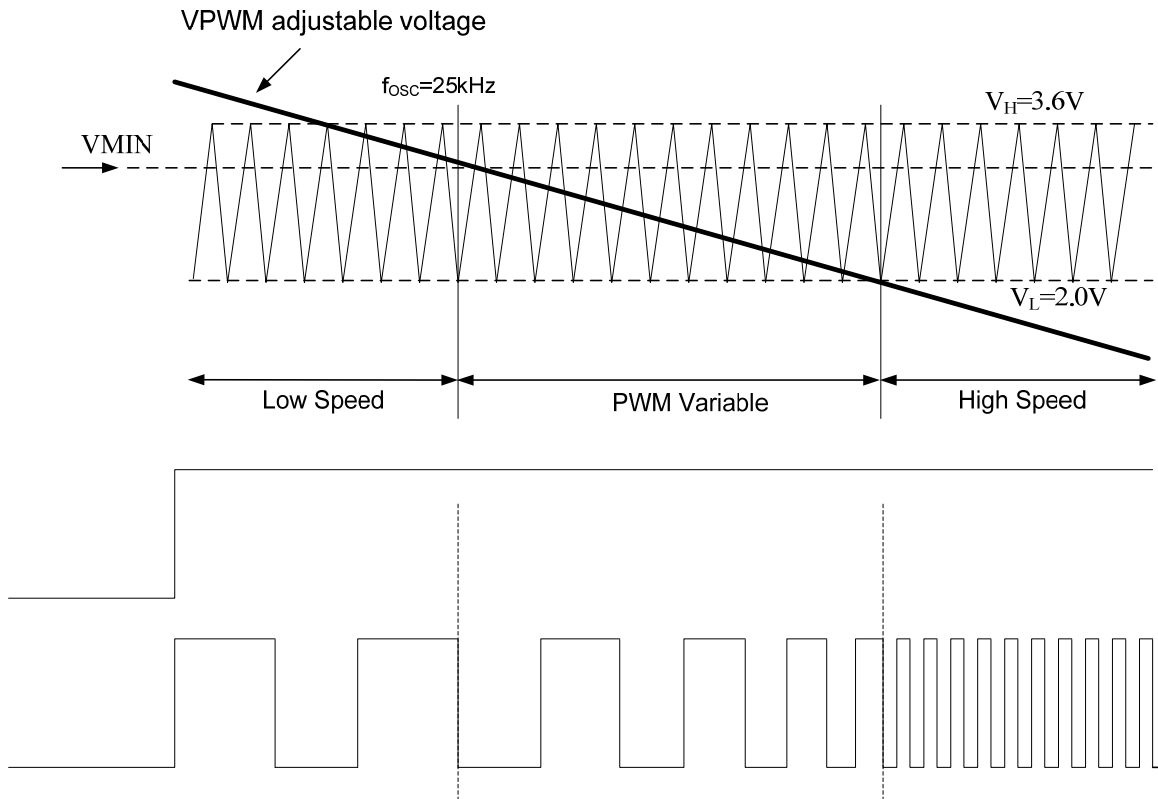

All parameters are tested under $V_{CC} = 12\text{V}$

Figure 9. Operating Diagram of AM4962

Typical Application (Note 4)

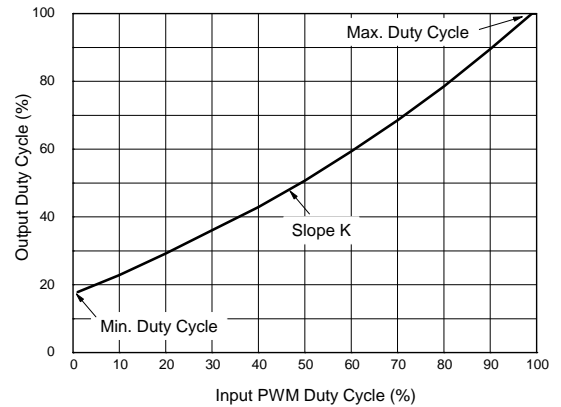
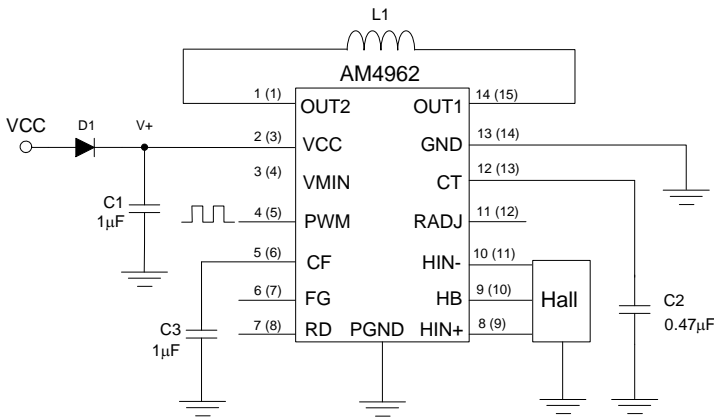
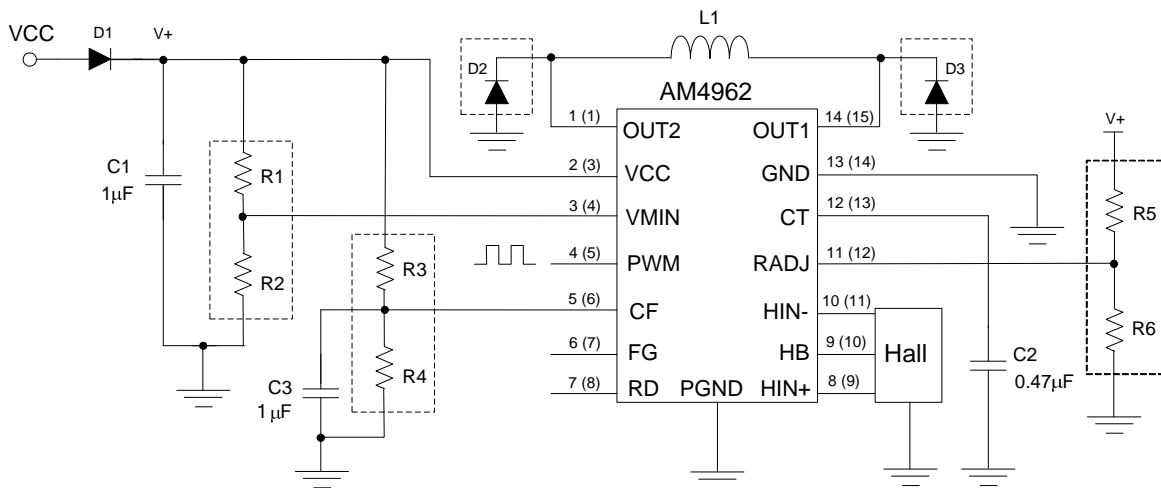

Figure 10

Application 1 (Default)



Application 2 (Slope K and Minimum/Maximum Duty Adjustable)

Note: D2 and D3 are recommended to be used when the current in coil L1 is higher than 300mA.

Figure 11. Typical Applications of AM4962

Typical Application (Note 4, Continued)

Note 4 (Refer to application circuit 2 unless otherwise noted.):

Adjust slope K of output PWM's duty vs. input PWM's duty

1. The default K is about 0.8 (application circuit 1).
2. Adding R5 can increase K (see Figure 12).
3. Adding R6 can decrease K (see Figure 13).

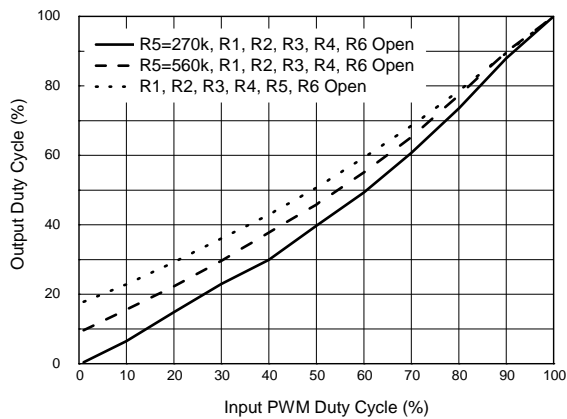

Figure 12

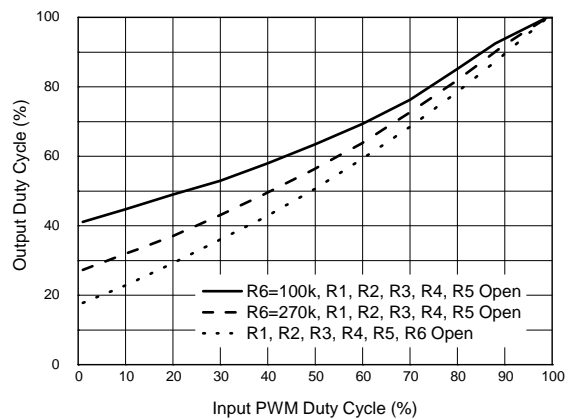

Figure 13

Adjust minimum duty of output PWM:

1. The default minimum duty of output PWM is about 20% (application circuit 1, Figure 10).
2. Decreasing R2 can increase minimum output PWM duty (see Figure 14).
3. Adding R5 can decrease minimum output PWM duty (see Figure 15).

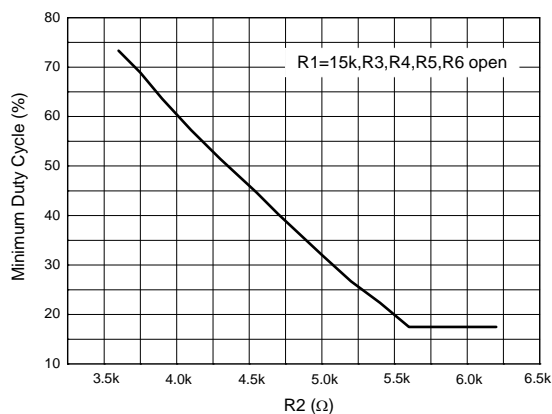

Figure 14

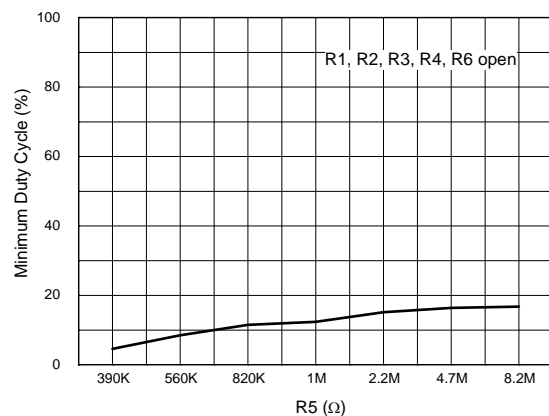

Figure 15

Typical Application (Note 4, Continued)

Adjust maximum duty of output PWM:

1. The default maximum output PWM duty is 100% (application circuit 1).
2. Adding R3 can decrease maximum output PWM duty (see Figure 16).
3. Adding R4 can increase maximum output PWM duty (see Figure 17).

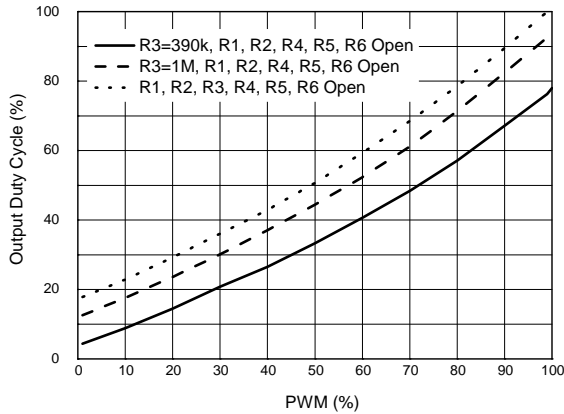

Figure 16

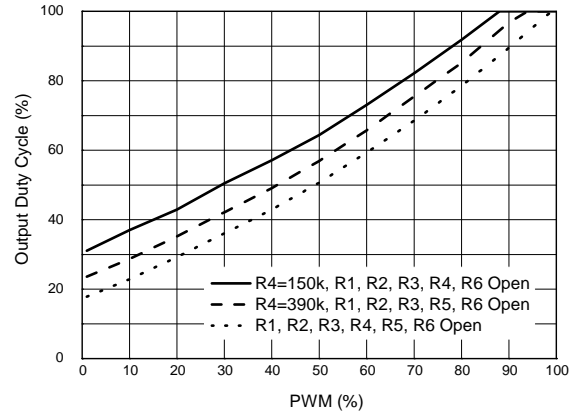
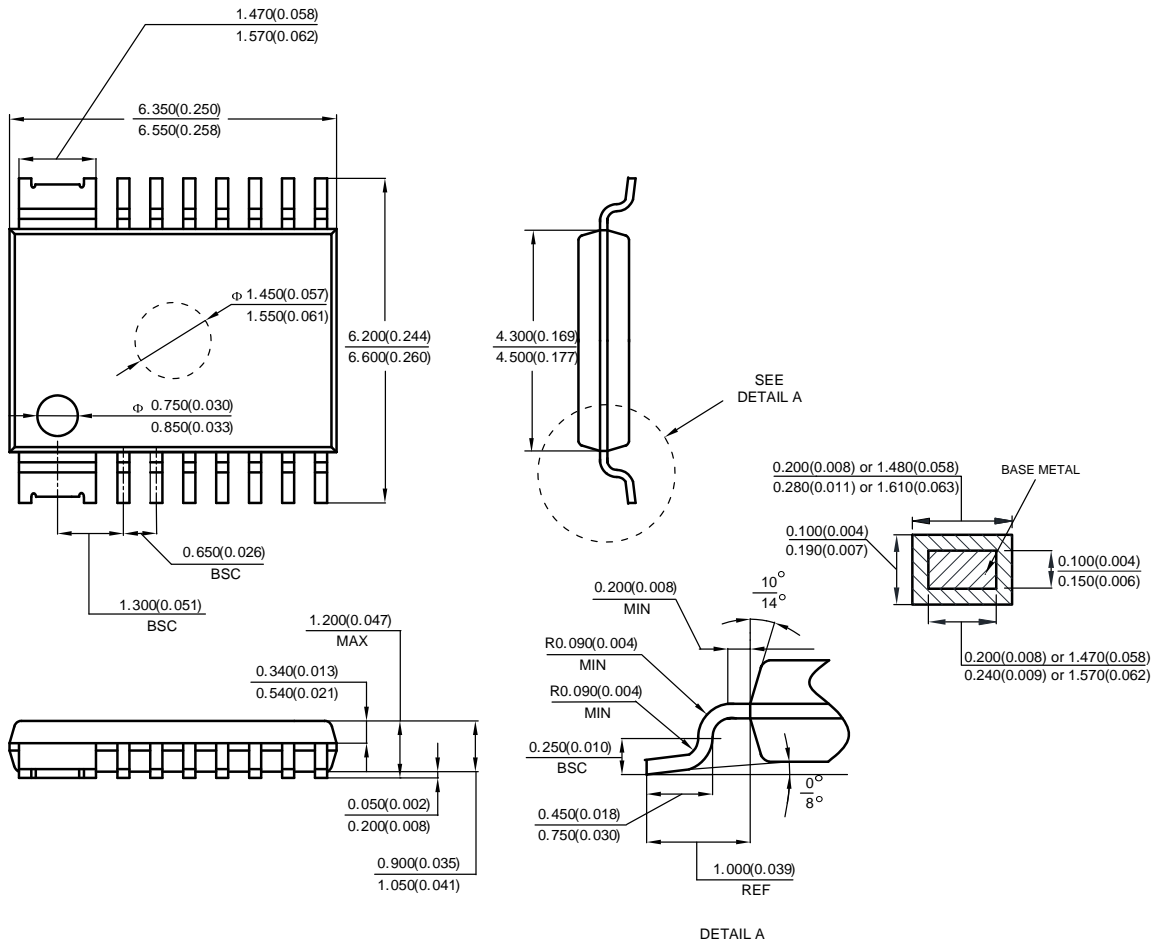

Figure 17

Mechanical Dimensions

HTSSOP-14

Unit: mm(inch)



Note: Eject hole, oriented hole and mold mark is optional.

Mechanical Dimensions (Continued)

SSOP-16

Unit: mm(inch)

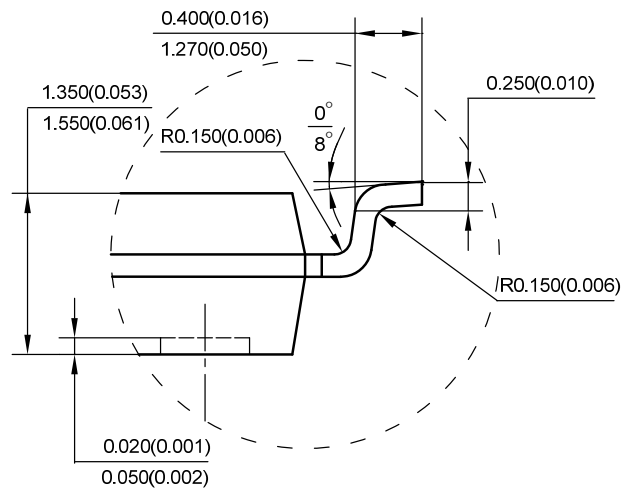
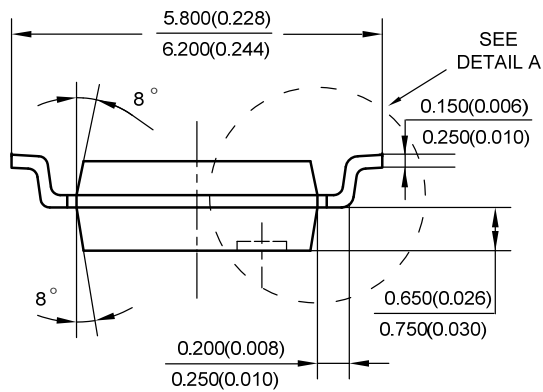
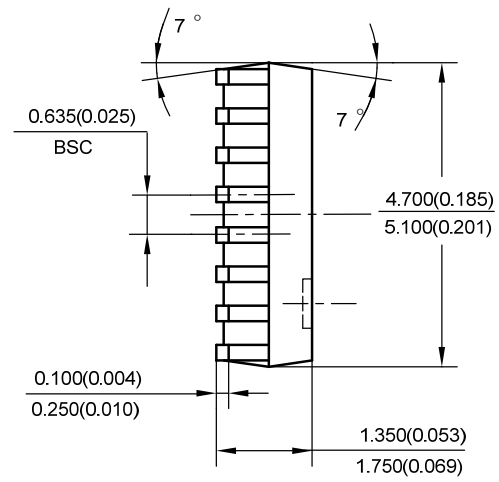
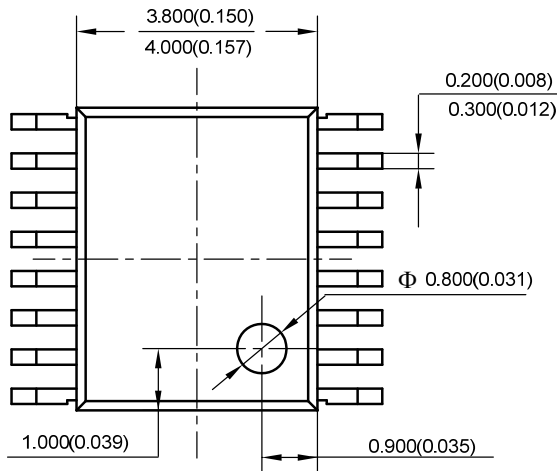

DETAIL A

Note: Eject hole, oriented hole and mold mark is optional.



BCD Semiconductor Manufacturing Limited

<http://www.bcdsemi.com>

IMPORTANT NOTICE

BCD Semiconductor Manufacturing Limited reserves the right to make changes without further notice to any products or specifications herein. BCD Semiconductor Manufacturing Limited does not assume any responsibility for use of any its products for any particular purpose, nor does BCD Semiconductor Manufacturing Limited assume any liability arising out of the application or use of any its products or circuits. BCD Semiconductor Manufacturing Limited does not convey any license under its patent rights or other rights nor the rights of others.

MAIN SITE

- Headquarters

BCD Semiconductor Manufacturing Limited

No. 1600, Zi Xing Road, Shanghai ZiZhu Science-based Industrial Park, 200241, China
Tel: +86-21-24162266, Fax: +86-21-24162277

- Wafer Fab

Shanghai SIM-BCD Semiconductor Manufacturing Co., Ltd.

800 Yi Shan Road, Shanghai 200233, China
Tel: +86-21-6485 1491, Fax: +86-21-5450 0008

REGIONAL SALES OFFICE

Shenzhen Office

Shanghai SIM-BCD Semiconductor Manufacturing Co., Ltd., Shenzhen Office

Unit A Room 1203, Skyworth Bldg., Gaoxin Ave. 1.S., Nanshan District, Shenzhen, China
Tel: +86-755-8826 7951
Fax: +86-755-8826 7865

Taiwan Office

BCD Semiconductor (Taiwan) Company Limited

4F, 298-1, Rui Guang Road, Nei-Hu District, Taipei, Taiwan
Tel: +886-2-2656 2808
Fax: +886-2-2656 2806

USA Office

BCD Semiconductor Corp.

30920 Huntwood Ave. Hayward, CA 94544, USA
Tel : +1-510-324-2988
Fax: +1-510-324-2788