

# AM574x Sitara™ Processors

## Silicon Revision 1.0

### 1 Device Overview

#### 1.1 Features

- Dual Arm® Cortex®-A15 microprocessor subsystem
- Up to two C66x floating-point VLIW DSP cores
  - Fully object-code compatible with C67x and C64x+
  - Up to thirty-two 16 × 16-bit fixed-point multiplies per cycle
- Up to 2.5MB of on-chip L3 RAM
- Two DDR3/DDR3L External Memory Interface (EMIF) modules
  - Supports rates up to DDR3-1333
  - Up to 2GB supported per EMIF
  - ECC supported on primary EMIF
- 2x Dual Arm® Cortex®-M4 coprocessors (IPU1 and IPU2)
- Up to two Embedded Vision Engines (EVEs)
- IVA-HD subsystem
  - 4K @ 15fps encode and decode support for H.264 CODEC
  - Other CODECs are up to 1080p60
- Display subsystem
  - Full-HD video (1920 × 1080p, 60 fps)
  - Multiple video inputs and video outputs
  - 2D and 3D graphics
  - Display controller with DMA engine and up to three pipelines
  - HDMI™ encoder: HDMI 1.4a and DVI 1.0 compliant
- 2x dual-core Programmable Real-Time Unit and Industrial Communication Subsystem (PRU-ICSS)
- 2D-graphics accelerator (BB2D) subsystem
  - Vivante® GC320 core
- Video Processing Engine (VPE)
- Dual-core PowerVR® SGX544 3D GPU
- Secure boot support
  - Hardware-enforced root-of-trust
  - Customer programmable keys and OTP data
  - Support for takeover protection, IP protection, and anti-roll back protection
- Cryptographic acceleration support
  - Supports cryptographic cores
    - AES – 128/192/256-bits key sizes
    - 3DES – 56/112/168-bits key sizes
    - MD5, SHA1
    - SHA2 – 224/256/384/512
  - True random number generator
  - DMA support
- Debug security
  - Secure software controlled debug access
  - Security aware debugging
- Trusted Execution Environment (TEE) support
  - Arm TrustZone® based TEE
  - Extensive firewall support for isolation
  - Secure DMA path and interconnect
  - Secure watchdog/timer/IPC
- Two Video Input Port (VIP) modules
  - Support for up to eight multiplexed input ports
- General-Purpose Memory Controller (GPMC)
- Enhanced Direct Memory Access (EDMA) controller
- 2-port Gigabit Ethernet switch
- Sixteen 32-bit general-purpose timers
- 32-bit MPU watchdog timer
- Five Inter-Integrated Circuit (I<sup>2</sup>C™) ports
- HDQ/ 1-Wire® interface
- Ten configurable UART/IrDA/CIR modules
- Four Multichannel Serial Peripheral Interfaces (McSPI)
- Quad Serial Peripheral Interface (QSPI)
- SATA Gen2 interface
- Eight Multichannel Audio Serial Port (McASP) modules
- SuperSpeed USB 3.0 dual-role device
- High Speed USB 2.0 dual-role device
- Four Multimedia Card/Secure Digital/ Secure Digital® Input Output Interfaces (MMC™/SD®/SDIO)
- PCI-Express® 3.0 (PCIe®) subsystems with two 5-Gbps lanes
  - One 2-lane Gen2-compliant port
  - or two 1-lane Gen2-compliant ports
- Up to two Controller Area Network (DCAN) modules
  - CAN 2.0B protocol
- Modular Controller Area Network (MCAN) module
  - CAN 2.0B protocol with available FD (flexible data rate) functionality



- Up to 247 General-Purpose I/O (GPIO) pins
- Power, reset, and clock management
- On-chip debug with CTools technology
- 28-nm CMOS technology
- 23 mm x 23 mm, 0.8-mm pitch, 760-pin BGA (ABZ)

## 1.2 Applications

- Industrial communication
- Human Machine Interface (HMI)
- Automation and control
- High performance applications
- Analytics
- Other general use

## 1.3 Description

AM574x Sitara™ processors are Arm® applications processors built to meet the intense processing needs of modern embedded products.

AM574x devices bring high processing performance through the maximum flexibility of a fully integrated mixed processor solution. The devices also combine programmable video processing with a highly integrated peripheral set. Cryptographic acceleration is available in every AM574x device.

Programmability is provided by dual-core Arm® Cortex®-A15 RISC CPUs with Neon™ extension, and two TI C66x VLIW floating-point DSP cores, and two Embedded Vision Engines (EVEs). The Arm CPUs allow developers to keep control functions separate from other algorithms programmed on the DSPs and coprocessors, thus reducing the complexity of the system software.

Additionally, TI provides a complete set of development tools for the Arm® and C66x DSP, including C compilers, a DSP assembly optimizer to simplify programming and scheduling, and a debugging interface for visibility into source code execution.

Cryptographic acceleration is available in all devices. All other supported security features, including support for secure boot, debug security and support for trusted execution environment are available on High-Security (HS) devices. For more information about HS devices, contact your TI representative.

**Device Information<sup>(1)</sup>**

PART NUMBER	PACKAGE	BODY SIZE
AM5746ABZ	FCBGA (760)	23.0 mm x 23.0 mm
AM5748ABZ	FCBGA (760)	23.0 mm x 23.0 mm
AM5749ABZ	FCBGA (760)	23.0 mm x 23.0 mm

(1) For more information, see [Section 9, Mechanical, Packaging, and Orderable Information](#).

### 1.4 Functional Block Diagram

Figure 1-1 is functional block diagram for the device.

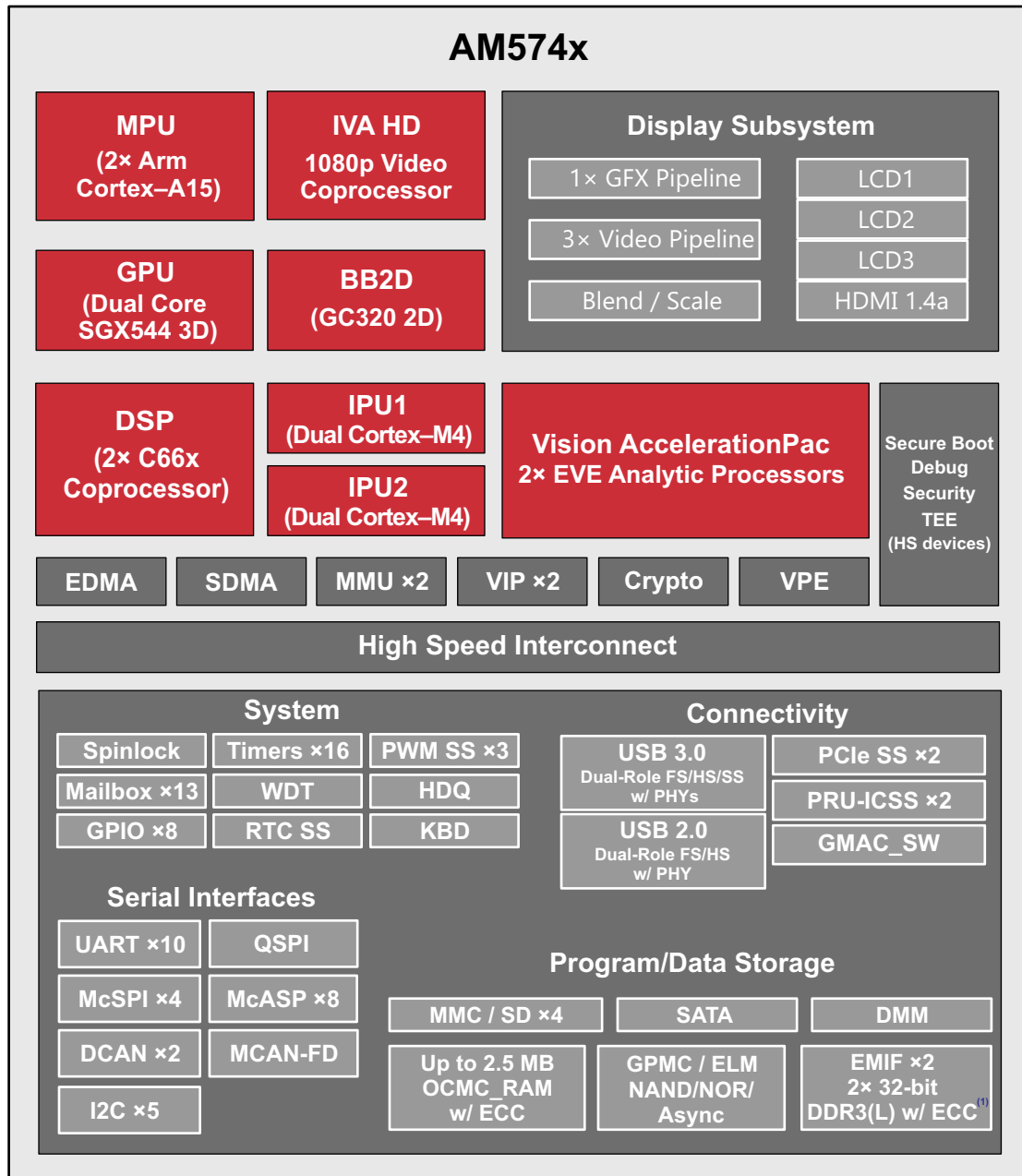

intro-001

Figure 1-1. AM574x Block Diagram

(1) ECC is only available on EMIF1.

## Table of Contents

<b>1</b>	<b>Device Overview</b> .....	<b><a href="#">1</a></b>	6.1	Overview .....	<a href="#">378</a>
1.1	Features .....	<a href="#">1</a>	6.2	Processor Subsystems .....	<a href="#">378</a>
1.2	Applications .....	<a href="#">2</a>	6.3	Accelerators and Coprocessors .....	<a href="#">389</a>
1.3	Description .....	<a href="#">2</a>	6.4	Other Subsystems .....	<a href="#">391</a>
1.4	Functional Block Diagram .....	<a href="#">3</a>	6.5	Identification .....	<a href="#">414</a>
<b>2</b>	<b>Revision History</b> .....	<b><a href="#">5</a></b>	6.6	Boot Modes .....	<a href="#">415</a>
<b>3</b>	<b>Device Comparison</b> .....	<b><a href="#">6</a></b>	<b>7</b>	<b>Applications, Implementation, and Layout</b> .....	<b><a href="#">419</a></b>
3.1	Related Products .....	<a href="#">8</a>	7.1	Power Supply Mapping .....	<a href="#">419</a>
<b>4</b>	<b>Terminal Configuration and Functions</b> .....	<b><a href="#">9</a></b>	7.2	DDR3 Board Design and Layout Guidelines .....	<a href="#">420</a>
4.1	Pin Diagram .....	<a href="#">9</a>	7.3	High Speed Differential Signal Routing Guidance .....	<a href="#">443</a>
4.2	Pin Attributes .....	<a href="#">9</a>	7.4	Power Distribution Network Implementation Guidance .....	<a href="#">443</a>
4.3	Signal Descriptions .....	<a href="#">90</a>	7.5	Thermal Solution Guidance .....	<a href="#">443</a>
4.4	Pin Multiplexing .....	<a href="#">137</a>	7.6	Single-Ended Interfaces .....	<a href="#">443</a>
4.5	Connections for Unused Pins .....	<a href="#">156</a>	7.7	LJCB_REFN/P Connections .....	<a href="#">445</a>
<b>5</b>	<b>Specifications</b> .....	<b><a href="#">157</a></b>	7.8	Clock Routing Guidelines .....	<a href="#">446</a>
5.1	Absolute Maximum Ratings .....	<a href="#">158</a>	<b>8</b>	<b>Device and Documentation Support</b> .....	<b><a href="#">448</a></b>
5.2	ESD Ratings .....	<a href="#">160</a>	8.1	Device Nomenclature .....	<a href="#">448</a>
5.3	Power-On Hours (POH) Limits .....	<a href="#">160</a>	8.2	Tools and Software .....	<a href="#">450</a>
5.4	Recommended Operating Conditions <sup>(4)</sup> .....	<a href="#">160</a>	8.3	Documentation Support .....	<a href="#">451</a>
5.5	Operating Performance Points .....	<a href="#">164</a>	8.4	Related Links .....	<a href="#">451</a>
5.6	Power Consumption Summary .....	<a href="#">183</a>	8.5	Support Resources .....	<a href="#">451</a>
5.7	Electrical Characteristics .....	<a href="#">183</a>	8.6	Trademarks .....	<a href="#">451</a>
5.8	VPP Specifications for One-Time Programmable (OTP) eFuses .....	<a href="#">192</a>	8.7	Electrostatic Discharge Caution .....	<a href="#">452</a>
5.9	Thermal Characteristics .....	<a href="#">192</a>	8.8	Glossary .....	<a href="#">452</a>
5.10	Timing Requirements and Switching Characteristics .....	<a href="#">194</a>	<b>9</b>	<b>Mechanical, Packaging, and Orderable Information</b> .....	<b><a href="#">453</a></b>
<b>6</b>	<b>Detailed Description</b> .....	<b><a href="#">378</a></b>	9.1	Packaging Information .....	<a href="#">453</a>

## 2 Revision History

Changes from March 8, 2019 to December 15, 2019 (from G Revision (March 2019) to H Revision)	Page
• Added reminders to disable unused pulls and RX pads in <a href="#">Section 4.2, Pin Attributes</a> .....	<a href="#">10</a>
• Added note to gpmc_a[22:19] and gpmc_a[27:24] signals about internal pulldowns activation in <a href="#">Table 4-1, Pin Attributes</a> .....	<a href="#">89</a>
• Added clarification notes for EMU[1:0] connections in <a href="#">Table 4-21, GPIOs Signal Descriptions</a> and <a href="#">Table 4-25, Debug Signal Descriptions</a> .....	<a href="#">121</a>
• Updated clock names in <a href="#">Table 5-6, Maximum Supported Frequency</a> .....	<a href="#">167</a>
• Removed footnote 1 regarding RTC oscillator in <a href="#">Table 5-6, Maximum Supported Frequency</a> .....	<a href="#">167</a>
• Updated Power-Down Sequencing diagrams and footnotes in <a href="#">Section 5.10.3, Power Supply Sequences</a> .....	<a href="#">197</a>
• Updated EMIF_DLL_FCLK max rate in <a href="#">Table 5-32, DLL Characteristics</a> .....	<a href="#">214</a>
• Updated GPMC Synchronous Mode footnote .....	<a href="#">248</a>
• Added MII_TXER timing to <a href="#">Section 5.10.6.18.1, GMAC MII Timings</a> .....	<a href="#">310</a>
• Updated <a href="#">Figure 5-72, GMAC MDIO diagrams</a> and MDIO7 parameter values in <a href="#">Table 5-105, Switching Characteristics Over Recommended Operating Conditions for MDIO Output</a> .....	<a href="#">311</a>
• Updated <a href="#">Section 6, Detailed Description</a> .....	<a href="#">378</a>
• Updated information about WD_TIMER1 in <a href="#">Section 6.4.3.3, Timers</a> .....	<a href="#">398</a>
• Added <a href="#">Section 6.5, Identification</a> and <a href="#">Section 6.6, Boot Modes</a> .....	<a href="#">414</a>
• Added note regarding DDR ECC solutions to <a href="#">Table 7-3, Supported DDR3 Device Combinations</a> .....	<a href="#">421</a>
• Added clarifications about validated DDR topology in <a href="#">Section 7.2.2.15, CK and ADDR_CTRL Topologies and Routing Definition</a> .....	<a href="#">430</a>
• Updated note for cosmetic marks on package in <a href="#">Section 8.1.1, Standard Package Symbolization</a> .....	<a href="#">448</a>
• Updated reference name to errata document in <a href="#">Section 8.3, Documentation Support</a> .....	<a href="#">451</a>

### 3 Device Comparison

Table 3-1 shows a comparison between AM574x devices, highlighting the differences. For a comparison of the full AM57xx family of devices, refer to [Parametric Table](#).

**Table 3-1. Device Comparison**

FEATURES		DEVICE			
		AM5749	AM5748	AM5746	
<b>Features</b>					
CTRL_WKUP_STD_FUSE_DIE_ID_2[31:24] Base PN register bit field value <sup>(6)</sup>		AM5749: 166 (0xA6)	AM5748: 92 (0x5C)	AM5746: 90 (0x5A)	
		AM5749-E: 95 (0x5F)	AM5748-E: 93 (0x5D)	AM5746-E: 91 (0x5B)	
<b>Processors/ Accelerators</b>					
Speed Grades		See <a href="#">Table 5-2</a>			
Dual Arm Cortex-A15 Microprocessor Subsystem (MPU)	MPU core 0	Yes	Yes	Yes	
	MPU core 1	Yes	Yes	Yes	
C66x VLIW DSP	DSP1 (with L1D ECC)	Yes	Yes	Yes	
	DSP2 (with L1D ECC)	Yes	Yes	Yes	
BitBLT 2D Hardware Acceleration Engine (BB2D)	BB2D	Yes	Yes	Not Supported <sup>(1)</sup>	
Display Subsystem	VOUT1	Yes	Yes	Not Supported <sup>(1)</sup>	
	VOUT2	Yes	Yes	Not Supported <sup>(1)</sup>	
	VOUT3	Yes	Yes	Not Supported <sup>(1)</sup>	
	HDMI	Yes	Yes	Not Supported <sup>(1)</sup>	
Embedded Vision Engine (EVE)	EVE1	Yes	Not Supported <sup>(1)</sup>		
	EVE2	Yes	Not Supported <sup>(1)</sup>		
Dual Arm Cortex-M4 Image Processing Unit (IPU)	IPU1	Yes	Yes	Yes	
	IPU2	Yes	Yes	Yes	
Image Video Accelerator (IVA)	IVA	Yes	Yes	Not Supported <sup>(1)</sup>	
SGX544 Dual-Core 3D Graphics Processing Unit (GPU)	GPU	Yes	Yes	Not Supported <sup>(1)</sup>	
Imaging Subsystem (ISS)	ISP	Not Supported <sup>(1)</sup>			
	WDR & Mesh LDC <sup>(7)</sup>	Not Supported <sup>(1)</sup>			
	CAL_B	Not Supported <sup>(1)</sup>			
Video Input Port (VIP)	VIP1	vin1a	Yes	Yes	Yes
		vin1b	Yes	Yes	Yes
		vin2a	Yes	Yes	Yes
		vin2b	Yes	Yes	Yes
	VIP2	vin3a	Yes	Yes	Yes
		vin3b	Yes	Yes	Yes
		vin4a	Yes	Yes	Yes
		vin4b	Yes	Yes	Yes
	VIP3	vin5a	Not Supported <sup>(1)</sup>		
		vin6a	Not Supported <sup>(1)</sup>		
Video Processing Engine (VPE)	VPE	Yes	Yes	Yes	
<b>Program/Data Storage</b>					
On-Chip Shared Memory (RAM)	OCCM_RAM	2.5MB	2.5MB	2.5MB	
General-Purpose Memory Controller (GPMC)	GPMC	Yes	Yes	Yes	

Table 3-1. Device Comparison (continued)

FEATURES		DEVICE		
		AM5749	AM5748	AM5746
DDR3 Memory Controller <sup>(2)</sup>	EMIF1	up to 2GB	up to 2GB	up to 2GB
	EMIF2	up to 2GB	up to 2GB	up to 2GB
Dynamic Memory Manager (DMM)	DMM	Yes	Yes	Yes
<b>Radio Support</b>				
Audio Tracking Logic (ATL)	ATL	Not Supported <sup>(1)</sup>		
Viterbi Coprocessor (VCP)	VCP1	Not Supported <sup>(1)</sup>		
	VCP2	Not Supported <sup>(1)</sup>		
<b>Peripherals</b>				
Controller Area Network Interface (CAN)	DCAN1 <sup>(5)</sup>	Yes	Yes	Yes
	DCAN2 <sup>(5)</sup>	Yes	Yes	Yes
	MCAN with FD <sup>(5)</sup>	Yes	Yes	Yes
Enhanced DMA (EDMA)	EDMA	Yes	Yes	Yes
System DMA (DMA_SYSTEM)	DMA_SYSTEM	Yes	Yes	Yes
Ethernet Subsystem (Ethernet SS)	GMAC_SW[0]	MII, RMII, or RGMII	MII, RMII, or RGMII	MII, RMII, or RGMII
	GMAC_SW[1]	MII, RMII, or RGMII	MII, RMII, or RGMII	MII, RMII, or RGMII
General-Purpose I/O (GPIO)	GPIO	up to 247	up to 247	up to 247
Inter-Integrated Circuit Interface (I2C)	I2C	5	5	5
System Mailbox Module	MAILBOX	13	13	13
Media Local Bus Subsystem (MLB) <sup>(3)</sup>	MLB	Not Supported <sup>(1)</sup>		
Multichannel Audio Serial Port (McASP)	McASP1	16 serializers	16 serializers	16 serializers
	McASP2	16 serializers	16 serializers	16 serializers
	McASP3	4 serializers	4 serializers	4 serializers
	McASP4	4 serializers	4 serializers	4 serializers
	McASP5	4 serializers	4 serializers	4 serializers
	McASP6	4 serializers	4 serializers	4 serializers
	McASP7	4 serializers	4 serializers	4 serializers
	McASP8	4 serializers	4 serializers	4 serializers
MultiMedia Card/Secure Digital/Secure Digital Input Output Interface (MMC/SD/SDIO)	MMC1	1x UHSI 4b	1x UHSI 4b	1x UHSI 4b
	MMC2	1x eMMC 8b	1x eMMC 8b	1x eMMC 8b
	MMC3	1x SDIO 8b	1x SDIO 8b	1x SDIO 8b
	MMC4	1x SDIO 4b	1x SDIO 4b	1x SDIO 4b
PCI-Express 3.0 Port with Integrated PHY	PCIe_SS1	Yes	Yes	Yes
	PCIe_SS2	Yes	Yes	Yes
2x Programmable Real-Time Unit Subsystem and Industrial Communication Subsystem (PRU-ICSS)	PRU-ICSS1	Yes	Yes	Yes
	PRU-ICSS2	Yes	Yes	Yes
Serial Advanced Technology Attachment (SATA)	SATA	Yes	Yes	Yes
Real-Time Clock Subsystem (RTCSS)	RTCSS <sup>(4)</sup>	Yes	Yes	Yes
Multichannel Serial Peripheral Interface (McSPI)	McSPI	4	4	4
HDQ / 1-Wire (HDQ1W)	HDQ1W	Yes	Yes	Yes
Quad SPI (QSPI)	QSPI	Yes	Yes	Yes
Spinlock Module	SPINLOCK	Yes	Yes	Yes
Keyboard Controller (KBD)	KBD	Yes	Yes	Yes
Timers, General-Purpose	TIMER	16	16	16
Timer, Watchdog	WATCHDOG TIMER	Yes	Yes	Yes

**Table 3-1. Device Comparison (continued)**

FEATURES		DEVICE		
		AM5749	AM5748	AM5746
Pulse-Width Modulation Subsystem (PWMSS)	PWMSS1	Yes	Yes	Yes
	PWMSS2	Yes	Yes	Yes
	PWMSS3	Yes	Yes	Yes
Universal Asynchronous Receiver/Transmitter (UART)	UART	10	10	10
Universal Serial Bus (USB3.0)	USB1 (SuperSpeed, Dual-Role-Device [DRD])	Yes	Yes	Yes
Universal Serial Bus (USB2.0)	USB2 (High Speed, Dual-Role-Device [DRD], with embedded HS PHY)	Yes	Yes	Yes
	USB3 (High Speed, OTG2.0, with ULPI)	Not Supported <sup>(1)</sup>		
	USB4 (High Speed, OTG2.0, with ULPI)	Not Supported <sup>(1)</sup>		

- (1) Features noted as “not supported” must not be used. Their functionality is not supported by TI for this family of devices. These features are subject to removal without notice on future device revisions. Any information regarding the unsupported features has been retained in the documentation solely for the purpose of clarifying signal names or for consistency with previous feature descriptions.
- (2) In the Unified L3 memory map, there is maximum of 2GB of SDRAM space which is available to all L3 initiators including MPU (MPU, GPU, DSP, IVA, DMA, etc). Typically this space is interleaved across both EMIFs to optimize memory performance. If a system populates > 2GB of physical memory, that additional addressable space can be accessed only by the MPU via the Arm V7 Large Physical Address Extensions (LPAE).
- (3) MLB power rails (vdds\_mlbp) must be connected to a 1.8 V power supply even this feature is not supported.
- (4) RTC-only mode is not a supported feature.
- (5) DCAN1 has one pin mux option that can optionally be used for MCAN functionality. DCAN2 has two pin mux options, one of which can be optionally used for MCAN functionality.
- (6) For more details about the CTRL\_WKUP\_STD\_FUSE\_DIE\_ID\_2 register and Base PN bit field, see the *AM574x Technical Reference Manual*.
- (7) Wide Dynamic Range and Lens Distortion Correction.

### 3.1 Related Products

**Sitara™ processors** Broad family of scalable processors based on Arm® Cortex®-A cores and TI C66x DSP cores with flexible accelerators, peripherals, connectivity and unified software support – perfect for sensors to servers. Sitara processors have the reliability needed for use in industrial applications.

**AM57x Sitara™ processors** AM57x Sitara™ processors are highly integrated devices that enable high-performance and multimedia applications. In addition to the Arm® Cortex®-A15 cores and TI C66x DSP cores, on-board accelerators provide enhanced vision and machine learning capabilities, support for multiple industrial Ethernet protocols, and video processing.

**Sitara™ processors applications** Sitara™ processors provide scalable solutions for a wide range of applications from HMI and gateways to more complex equipment such as drives and substation automation equipment. Sitara processors also offer multi-protocol support for industrial communication protocols such as EtherCAT®, Ethernet/IP, and Profinet.

**Reference Designs and Evaluation Modules** TI provides many reference designs containing ‘building block’ solutions to enable customers to rapidly develop their own unique products and solutions. EVMs are also provided to help kick-start product development.

**Companion Products for AM574x** Review products that are frequently purchased or used in conjunction with this product to complete your design.



## 4 Terminal Configuration and Functions

### 4.1 Pin Diagram

Figure 4-1 shows the ball locations for the 760 plastic ball grid array (PBGA) package and are used in conjunction with Table 4-1 through Table 4-32 to locate signal names and ball grid numbers.

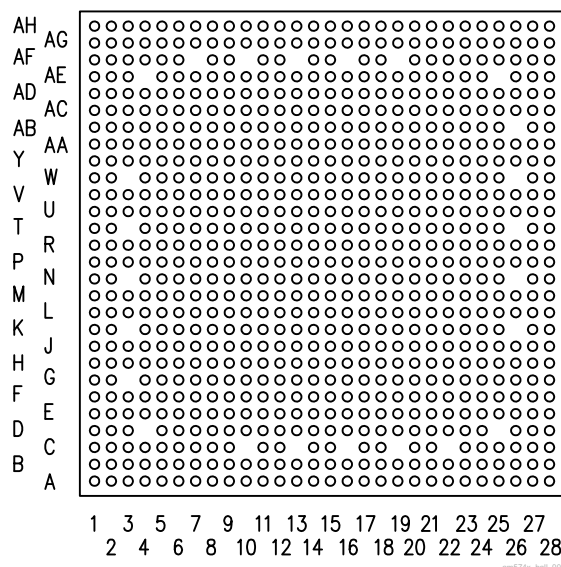

Figure 4-1. ABZ S-PBGA-N760 Package (Bottom View)

#### NOTE

The following bottom balls are not connected: AF7 / AF10 / AF13 / AF16 / AF19 / AE4 / AE25 / AB26 / W3 / W26 / T3 / T26 / N3 / N26 / K3 / K26 / G3 / D4 / D25 / C10 / C13 / C16 / C19 / C22.

These balls do not exist on the package.

### 4.2 Pin Attributes

Table 4-1 describes the terminal characteristics and the signals multiplexed on each ball. The following list describes the table column headers:

1. **BALL NUMBER:** Ball number(s) on the bottom side associated with each signal on the bottom.
2. **BALL NAME:** Mechanical name from package device (name is taken from muxmode 0).
3. **SIGNAL NAME:** Names of signals multiplexed on each ball (also notice that the name of the ball is the signal name in muxmode 0).

#### NOTE

Table 4-1 does not consider the subsystem multiplexing signals. Subsystem multiplexing signals are described in Section 4.3, *Signal Descriptions*.

#### NOTE

In the Driver off mode, the buffer is configured in high-impedance.

**NOTE**

In some cases [Table 4-1](#) may present more than one signal name per muxmode for the same ball. First signal in the list is the dominant function as selected via CTRL\_CORE\_PAD\_\* register. All other signals are virtual functions that present alternate multiplexing options. This virtual functions are controlled via CTRL\_CORE\_ALT\_SELECT\_MUX or CTRL\_CORE\_VIP\_MUX\_SELECT register. For more information on how to use this options, please refer to the device TRM, *Control Module* chapter, *Pad Configuration Registers* section.

4. **PN:** This column shows if the functionality is applicable for **AM5746** device. Note that the Pin Attributes table presents a functionality of super set. If the cell is empty it means that the signal is available in all devices.
  - **Yes** - Functionality is presented in **AM5746**
  - **No** - Functionality not presented in **AM5746**
 An empty box means Yes.
5. **MUXMODE:** Multiplexing mode number:
  - a. MUXMODE 0 is the primary muxmode; this means that when MUXMODE = 0, the function mapped on the pin corresponds to the name of the pin. The primary muxmode is not necessarily the default muxmode.

**NOTE**

The default muxmode is the mode at the release of the reset; also see the RESET REL. MUXMODE column.

- b. MUXMODE 1 through 15 are possible muxmodes for alternate functions. On each pin, some muxmodes are effectively used for alternate functions, while some muxmodes are not used. Only MUXMODE values which correspond to defined functions should be used.
  - c. An empty box means Not Applicable
6. **TYPE:** Signal type and direction:
  - I = Input
  - O = Output
  - IO = Input or Output
  - D = Open drain
  - DS = Differential Signaling
  - A = Analog
  - PWR = Power
  - GND = Ground
  - CAP = LDO Capacitor

**NOTE**

The RX buffer within the pad logic should be disabled on all pins that are not being used as an input. For more information, see the *Control Module / Control Module Functional Description / PAD Functional Multiplexing and Configuration* section in the device TRM.

7. **BALL RESET STATE:** The state of the terminal at power-on reset:
  - drive 0 (OFF): The buffer drives  $V_{OL}$  (pulldown or pullup resistor not activated).
  - drive 1 (OFF): The buffer drives  $V_{OH}$  (pulldown or pullup resistor not activated).
  - OFF: High-impedance
  - PD: High-impedance with an active pulldown resistor
  - PU: High-impedance with an active pullup resistor
  - An empty box means Not Applicable

---

**NOTE**

Designs that contain pullup or pulldown resistors, either on the board or in attached devices that oppose internal pullup or pulldown resistors, that are active while the device is held in reset, must not remain in reset for long periods of time.

---

8. **BALL RESET REL.STATE:** The state of the terminal at the deactivation of the rstoutn signal (also mapped to the PRCM SYS\_WARM\_OUT\_RST signal).
- drive 0 (OFF): The buffer drives  $V_{OL}$  (pulldown or pullup resistor not activated).
  - drive clk (OFF): The buffer drives a toggling clock (pulldown or pullup resistor not activated).
  - drive 1 (OFF): The buffer drives  $V_{OH}$  (pulldown or pullup resistor not activated).
  - OFF: High-impedance
  - PD: High-impedance with an active pulldown resistor
  - PU: High-impedance with an active pullup resistor
  - An empty box means Not Applicable
- 

**NOTE**

For more information on the CORE\_PWRON\_RET\_RST reset signal and its reset sources, see the *Power Reset and Clock Management / PRCM Reset Management Functional Description* section in the device TRM.

---

9. **BALL RESET REL. MUXMODE:** This muxmode is automatically configured at the release of the rstoutn signal (also mapped to the PRCM SYS\_WARM\_OUT\_RST signal).  
An empty box means Not Applicable.
10. **I/O VOLTAGE VALUE:** This column describes the IO voltage value (the corresponding power supply).  
An empty box means Not Applicable.
11. **POWER:** The voltage supply that powers the terminal IO buffers.  
An empty box means Not Applicable.
12. **HYS:** Indicates if the input buffer is with hysteresis:
- Yes: With hysteresis
  - No: Without hysteresis
  - An empty box: Not Applicable
- 

**NOTE**

For more information, see the hysteresis values in [Section 5.7, Electrical Characteristics](#).

---

13. **BUFFER TYPE:** Drive strength of the associated output buffer.  
An empty box means Not Applicable.
- 

**NOTE**

For programmable buffer strength:

- The default value is given in [Table 4-1](#).
  - A note describes all possible values according to the selected muxmode.
- 

14. **PULLUP / PULLDOWN TYPE:** Denotes the presence of an internal pullup or pulldown resistor. Pullup and pulldown resistors can be enabled or disabled via software.
- PU: Internal pullup
  - PD: Internal pulldown
  - PU/PD: Internal pullup and pulldown
  - PUx/PDy: Programmable internal pullup and pulldown
  - PDy: Programmable internal pulldown
  - An empty box means No pull

**NOTE**

Internal pullup or pulldown resistors must be disabled when opposed by an external pullup or pulldown resistor on the board or within an attached device.

15. **DSIS:** The deselected input state (DSIS) indicates the state driven on the peripheral input (logic "0", logic "1", or "PIN" level) when the peripheral pin function is not selected by any of the PINCNTLx registers.
- 0: Logic 0 driven on the peripheral's input signal port.
  - 1: Logic 1 driven on the peripheral's input signal port.
  - blank: Pin state driven on the peripheral's input signal port.

**NOTE**

Configuring two pins to the same input signal is not supported as it can yield unexpected results. This can be easily prevented with the proper software configuration (Hi-Z mode is not an input signal).

**NOTE**

When a pad is set into a multiplexing mode which is not defined by pin multiplexing, that pad's behavior is undefined. This should be avoided.

**CAUTION**

Not all exposed peripherals are supported on all AM574x devices. For peripherals supported on specific device from AM574x family of products refer to [Table 3-1, Device Comparison](#).

**NOTE**

Some of the DDR1 and DDR2 signals have an additional state change at the release of porz. The state that the signals change to at the release of porz is as follows:

drive 0 (OFF) for: ddr1\_csn0, ddr1\_ck, ddr1\_nck, ddr1\_casn, ddr1\_rasn, ddr1\_wen, ddr1\_ba[2:0], ddr1\_a[15:0], ddr2\_csn0, ddr2\_ck, ddr2\_nck, ddr2\_casn, ddr2\_rasn, ddr2\_wen, ddr2\_ba[2:0], ddr2\_a[15:0].

OFF for: ddr1\_ecc\_d[7:0], ddr1\_dqm[3:0], ddr1\_dqm\_ecc, ddr1\_dqs[3:0], ddr1\_dqsn[3:0], ddr1\_dqs\_ecc, ddr1\_dqsn\_ecc, ddr1\_d[31:0], ddr2\_dqm[3:0], ddr2\_dqs[3:0], ddr2\_dqsn[3:0], ddr2\_d[31:0].

Table 4-1. Pin Attributes<sup>(1)</sup>

BALL NUMBER [1]	BALL NAME [2]	SIGNAL NAME [3]	PN [4]	MUXMODE [5]	TYPE [6]	BALL RESET STATE [7]	BALL RESET REL. STATE [8]	BALL RESET REL. MUXMODE [9]	I/O VOLTAGE VALUE [10]	POWER [11]	HYS [12]	BUFFER TYPE [13]	PULL UP/DOWN TYPE [14]	DSIS [15]	
K9	cap_vbbldo_dspeve	cap_vbbldo_dspeve			CAP										
Y14	cap_vbbldo_gpu	cap_vbbldo_gpu			CAP										
R20	cap_vbbldo_iva	cap_vbbldo_iva			CAP										
J16	cap_vbbldo_mpu	cap_vbbldo_mpu			CAP										
L9	cap_vddram_core1	cap_vddram_core1			CAP										
J19	cap_vddram_core2	cap_vddram_core2			CAP										
Y15	cap_vddram_core3	cap_vddram_core3			CAP										
P19	cap_vddram_core4	cap_vddram_core4			CAP										
Y16	cap_vddram_core5	cap_vddram_core5			CAP										
J10	cap_vddram_dspeve1	cap_vddram_dspeve1			CAP										
J9	cap_vddram_dspeve2	cap_vddram_dspeve2			CAP										
Y13	cap_vddram_gpu	cap_vddram_gpu			CAP										
T20	cap_vddram_iva	cap_vddram_iva			CAP										
K16	cap_vddram_mpu1	cap_vddram_mpu1			CAP										
K19	cap_vddram_mpu2	cap_vddram_mpu2			CAP										
G19	dcan1_rx	dcan1_rx		0	IO	PU	PU	15	1.8/3.3	vddshv3	Yes	Dual Voltage LVCMOS	PU/PD		
		mcan_rx													
		uart8_txd		2	O										0
		mmc2_sdwp		3	I										
		sata1_led		4	O										
		hdmi1_cec	No	6	IO										
		gpio1_15		14	IO										
Driver off		15	I												
G20	dcan1_tx	dcan1_tx		0	IO	PU	PU	15	1.8/3.3	vddshv3	Yes	Dual Voltage LVCMOS	PU/PD		
		mcan_tx													
		uart8_rxd		2	I										1
		mmc2_sdcd		3	I										1
		hdmi1_hpd	No	6	I										
		gpio1_14		14	IO										
Driver off		15	I												
AD20	ddr1_a0	ddr1_a0		0	O	PD	drive 1 (OFF)		1.35/1.5/1.8	vdds_ddr1	No	LVCMOS DDR	Pux/PDy		
AC19	ddr1_a1	ddr1_a1		0	O	PD	drive 1 (OFF)		1.35/1.5/1.8	vdds_ddr1	No	LVCMOS DDR	Pux/PDy		
AC20	ddr1_a2	ddr1_a2		0	O	PD	drive 1 (OFF)		1.35/1.5/1.8	vdds_ddr1	No	LVCMOS DDR	Pux/PDy		
AB19	ddr1_a3	ddr1_a3		0	O	PD	drive 1 (OFF)		1.35/1.5/1.8	vdds_ddr1	No	LVCMOS DDR	Pux/PDy		

Table 4-1. Pin Attributes<sup>(1)</sup> (continued)

BALL NUMBER [1]	BALL NAME [2]	SIGNAL NAME [3]	PN [4]	MUXMODE [5]	TYPE [6]	BALL RESET STATE [7]	BALL RESET REL. STATE [8]	BALL RESET REL. MUXMODE [9]	I/O VOLTAGE VALUE [10]	POWER [11]	HYS [12]	BUFFER TYPE [13]	PULL UP/DOWN TYPE [14]	DSIS [15]
AF21	ddr1_a4	ddr1_a4		0	O	PD	drive 1 (OFF)		1.35/1.5/1.8	vdds_ddr1	No	LVC MOS DDR	Pux/PDy	
AH22	ddr1_a5	ddr1_a5		0	O	PD	drive 1 (OFF)		1.35/1.5/1.8	vdds_ddr1	No	LVC MOS DDR	Pux/PDy	
AG23	ddr1_a6	ddr1_a6		0	O	PD	drive 1 (OFF)		1.35/1.5/1.8	vdds_ddr1	No	LVC MOS DDR	Pux/PDy	
AE21	ddr1_a7	ddr1_a7		0	O	PD	drive 1 (OFF)		1.35/1.5/1.8	vdds_ddr1	No	LVC MOS DDR	Pux/PDy	
AF22	ddr1_a8	ddr1_a8		0	O	PD	drive 1 (OFF)		1.35/1.5/1.8	vdds_ddr1	No	LVC MOS DDR	Pux/PDy	
AE22	ddr1_a9	ddr1_a9		0	O	PD	drive 1 (OFF)		1.35/1.5/1.8	vdds_ddr1	No	LVC MOS DDR	Pux/PDy	
AD21	ddr1_a10	ddr1_a10		0	O	PD	drive 1 (OFF)		1.35/1.5/1.8	vdds_ddr1	No	LVC MOS DDR	Pux/PDy	
AD22	ddr1_a11	ddr1_a11		0	O	PD	drive 1 (OFF)		1.35/1.5/1.8	vdds_ddr1	No	LVC MOS DDR	Pux/PDy	
AC21	ddr1_a12	ddr1_a12		0	O	PD	drive 1 (OFF)		1.35/1.5/1.8	vdds_ddr1	No	LVC MOS DDR	Pux/PDy	
AF18	ddr1_a13	ddr1_a13		0	O	PD	drive 1 (OFF)		1.35/1.5/1.8	vdds_ddr1	No	LVC MOS DDR	Pux/PDy	
AE17	ddr1_a14	ddr1_a14		0	O	PD	drive 1 (OFF)		1.35/1.5/1.8	vdds_ddr1	No	LVC MOS DDR	Pux/PDy	
AD18	ddr1_a15	ddr1_a15		0	O	PD	drive 1 (OFF)		1.35/1.5/1.8	vdds_ddr1	No	LVC MOS DDR	Pux/PDy	
AF17	ddr1_ba0	ddr1_ba0		0	O	PD	drive 1 (OFF)		1.35/1.5/1.8	vdds_ddr1	No	LVC MOS DDR	Pux/PDy	
AE18	ddr1_ba1	ddr1_ba1		0	O	PD	drive 1 (OFF)		1.35/1.5/1.8	vdds_ddr1	No	LVC MOS DDR	Pux/PDy	
AB18	ddr1_ba2	ddr1_ba2		0	O	PD	drive 1 (OFF)		1.35/1.5/1.8	vdds_ddr1	No	LVC MOS DDR	Pux/PDy	
AC18	ddr1_casn	ddr1_casn		0	O	PD	drive 1 (OFF)		1.35/1.5/1.8	vdds_ddr1	No	LVC MOS DDR	Pux/PDy	
AG24	ddr1_ck	ddr1_ck		0	O	PD	drive clk (OFF)		1.35/1.5/1.8	vdds_ddr1	No	LVC MOS DDR	Pux/PDy	
AG22	ddr1_cke	ddr1_cke		0	O	PD	drive 0 (OFF)		1.35/1.5/1.8	vdds_ddr1	No	LVC MOS DDR	Pux/PDy	
AH23	ddr1_csn0	ddr1_csn0		0	O	PD	drive 1 (OFF)		1.35/1.5/1.8	vdds_ddr1	No	LVC MOS DDR	Pux/PDy	
AF25	ddr1_d0	ddr1_d0		0	IO	PD	PD		1.35/1.5/1.8	vdds_ddr1	No	LVC MOS DDR	Pux/PDy	
AF26	ddr1_d1	ddr1_d1		0	IO	PD	PD		1.35/1.5/1.8	vdds_ddr1	No	LVC MOS DDR	Pux/PDy	
AG26	ddr1_d2	ddr1_d2		0	IO	PD	PD		1.35/1.5/1.8	vdds_ddr1	No	LVC MOS DDR	Pux/PDy	
AH26	ddr1_d3	ddr1_d3		0	IO	PD	PD		1.35/1.5/1.8	vdds_ddr1	No	LVC MOS DDR	Pux/PDy	

**Table 4-1. Pin Attributes<sup>(1)</sup> (continued)**

BALL NUMBER [1]	BALL NAME [2]	SIGNAL NAME [3]	PN [4]	MUXMODE [5]	TYPE [6]	BALL RESET STATE [7]	BALL RESET REL. STATE [8]	BALL RESET REL. MUXMODE [9]	I/O VOLTAGE VALUE [10]	POWER [11]	HYS [12]	BUFFER TYPE [13]	PULL UP/DOWN TYPE [14]	DSIS [15]
AF24	ddr1_d4	ddr1_d4		0	IO	PD	PD		1.35/1.5/1.8	vdds_ddr1	No	LVC MOS DDR	Pux/PDy	
AE24	ddr1_d5	ddr1_d5		0	IO	PD	PD		1.35/1.5/1.8	vdds_ddr1	No	LVC MOS DDR	Pux/PDy	
AF23	ddr1_d6	ddr1_d6		0	IO	PD	PD		1.35/1.5/1.8	vdds_ddr1	No	LVC MOS DDR	Pux/PDy	
AE23	ddr1_d7	ddr1_d7		0	IO	PD	PD		1.35/1.5/1.8	vdds_ddr1	No	LVC MOS DDR	Pux/PDy	
AC23	ddr1_d8	ddr1_d8		0	IO	PD	PD		1.35/1.5/1.8	vdds_ddr1	No	LVC MOS DDR	Pux/PDy	
AF27	ddr1_d9	ddr1_d9		0	IO	PD	PD		1.35/1.5/1.8	vdds_ddr1	No	LVC MOS DDR	Pux/PDy	
AG27	ddr1_d10	ddr1_d10		0	IO	PD	PD		1.35/1.5/1.8	vdds_ddr1	No	LVC MOS DDR	Pux/PDy	
AF28	ddr1_d11	ddr1_d11		0	IO	PD	PD		1.35/1.5/1.8	vdds_ddr1	No	LVC MOS DDR	Pux/PDy	
AE26	ddr1_d12	ddr1_d12		0	IO	PD	PD		1.35/1.5/1.8	vdds_ddr1	No	LVC MOS DDR	Pux/PDy	
AC25	ddr1_d13	ddr1_d13		0	IO	PD	PD		1.35/1.5/1.8	vdds_ddr1	No	LVC MOS DDR	Pux/PDy	
AC24	ddr1_d14	ddr1_d14		0	IO	PD	PD		1.35/1.5/1.8	vdds_ddr1	No	LVC MOS DDR	Pux/PDy	
AD25	ddr1_d15	ddr1_d15		0	IO	PD	PD		1.35/1.5/1.8	vdds_ddr1	No	LVC MOS DDR	Pux/PDy	
V20	ddr1_d16	ddr1_d16		0	IO	PD	PD		1.35/1.5/1.8	vdds_ddr1	No	LVC MOS DDR	Pux/PDy	
W20	ddr1_d17	ddr1_d17		0	IO	PD	PD		1.35/1.5/1.8	vdds_ddr1	No	LVC MOS DDR	Pux/PDy	
AB28	ddr1_d18	ddr1_d18		0	IO	PD	PD		1.35/1.5/1.8	vdds_ddr1	No	LVC MOS DDR	Pux/PDy	
AC28	ddr1_d19	ddr1_d19		0	IO	PD	PD		1.35/1.5/1.8	vdds_ddr1	No	LVC MOS DDR	Pux/PDy	
AC27	ddr1_d20	ddr1_d20		0	IO	PD	PD		1.35/1.5/1.8	vdds_ddr1	No	LVC MOS DDR	Pux/PDy	
Y19	ddr1_d21	ddr1_d21		0	IO	PD	PD		1.35/1.5/1.8	vdds_ddr1	No	LVC MOS DDR	Pux/PDy	
AB27	ddr1_d22	ddr1_d22		0	IO	PD	PD		1.35/1.5/1.8	vdds_ddr1	No	LVC MOS DDR	Pux/PDy	
Y20	ddr1_d23	ddr1_d23		0	IO	PD	PD		1.35/1.5/1.8	vdds_ddr1	No	LVC MOS DDR	Pux/PDy	
AA23	ddr1_d24	ddr1_d24		0	IO	PD	PD		1.35/1.5/1.8	vdds_ddr1	No	LVC MOS DDR	Pux/PDy	
Y22	ddr1_d25	ddr1_d25		0	IO	PD	PD		1.35/1.5/1.8	vdds_ddr1	No	LVC MOS DDR	Pux/PDy	
Y23	ddr1_d26	ddr1_d26		0	IO	PD	PD		1.35/1.5/1.8	vdds_ddr1	No	LVC MOS DDR	Pux/PDy	

Table 4-1. Pin Attributes<sup>(1)</sup> (continued)

BALL NUMBER [1]	BALL NAME [2]	SIGNAL NAME [3]	PN [4]	MUXMODE [5]	TYPE [6]	BALL RESET STATE [7]	BALL RESET REL. STATE [8]	BALL RESET REL. MUXMODE [9]	I/O VOLTAGE VALUE [10]	POWER [11]	HYS [12]	BUFFER TYPE [13]	PULL UP/DOWN TYPE [14]	DSIS [15]
AA24	ddr1_d27	ddr1_d27		0	IO	PD	PD		1.35/1.5/1.8	vdds_ddr1	No	LVC MOS DDR	Pux/PDy	
Y24	ddr1_d28	ddr1_d28		0	IO	PD	PD		1.35/1.5/1.8	vdds_ddr1	No	LVC MOS DDR	Pux/PDy	
AA26	ddr1_d29	ddr1_d29		0	IO	PD	PD		1.35/1.5/1.8	vdds_ddr1	No	LVC MOS DDR	Pux/PDy	
AA25	ddr1_d30	ddr1_d30		0	IO	PD	PD		1.35/1.5/1.8	vdds_ddr1	No	LVC MOS DDR	Pux/PDy	
AA28	ddr1_d31	ddr1_d31		0	IO	PD	PD		1.35/1.5/1.8	vdds_ddr1	No	LVC MOS DDR	Pux/PDy	
AD23	ddr1_dqm0	ddr1_dqm0		0	O	PD	PD		1.35/1.5/1.8	vdds_ddr1	No	LVC MOS DDR	Pux/PDy	
AB23	ddr1_dqm1	ddr1_dqm1		0	O	PD	PD		1.35/1.5/1.8	vdds_ddr1	No	LVC MOS DDR	Pux/PDy	
AC26	ddr1_dqm2	ddr1_dqm2		0	O	PD	PD		1.35/1.5/1.8	vdds_ddr1	No	LVC MOS DDR	Pux/PDy	
AA27	ddr1_dqm3	ddr1_dqm3		0	O	PD	PD		1.35/1.5/1.8	vdds_ddr1	No	LVC MOS DDR	Pux/PDy	
V26	ddr1_dqm_ecc	ddr1_dqm_ecc		0	O	PD	PD		1.35/1.5/1.8	vdds_ddr1	No	LVC MOS DDR	Pux/PDy	
AH25	ddr1_dqs0	ddr1_dqs0		0	IO	PD	PD		1.35/1.5/1.8	vdds_ddr1		LVC MOS DDR	Pux/PDy	
AE27	ddr1_dqs1	ddr1_dqs1		0	IO	PD	PD		1.35/1.5/1.8	vdds_ddr1		LVC MOS DDR	Pux/PDy	
AD27	ddr1_dqs2	ddr1_dqs2		0	IO	PD	PD		1.35/1.5/1.8	vdds_ddr1		LVC MOS DDR	Pux/PDy	
Y28	ddr1_dqs3	ddr1_dqs3		0	IO	PD	PD		1.35/1.5/1.8	vdds_ddr1		LVC MOS DDR	Pux/PDy	
AG25	ddr1_dqsn0	ddr1_dqsn0		0	IO	PU	PU		1.35/1.5/1.8	vdds_ddr1		LVC MOS DDR	Pux/PDy	
AE28	ddr1_dqsn1	ddr1_dqsn1		0	IO	PU	PU		1.35/1.5/1.8	vdds_ddr1		LVC MOS DDR	Pux/PDy	
AD28	ddr1_dqsn2	ddr1_dqsn2		0	IO	PU	PU		1.35/1.5/1.8	vdds_ddr1		LVC MOS DDR	Pux/PDy	
Y27	ddr1_dqsn3	ddr1_dqsn3		0	IO	PU	PU		1.35/1.5/1.8	vdds_ddr1		LVC MOS DDR	Pux/PDy	
V28	ddr1_dqsn_ecc	ddr1_dqsn_ecc		0	IO	PU	PU		1.35/1.5/1.8	vdds_ddr1		LVC MOS DDR	Pux/PDy	
V27	ddr1_dqs_ecc	ddr1_dqs_ecc		0	IO	PD	PD		1.35/1.5/1.8	vdds_ddr1		LVC MOS DDR	Pux/PDy	
W22	ddr1_ecc_d0	ddr1_ecc_d0		0	IO	PD	PD		1.35/1.5/1.8	vdds_ddr1	No	LVC MOS DDR	Pux/PDy	
V23	ddr1_ecc_d1	ddr1_ecc_d1		0	IO	PD	PD		1.35/1.5/1.8	vdds_ddr1	No	LVC MOS DDR	Pux/PDy	
W19	ddr1_ecc_d2	ddr1_ecc_d2		0	IO	PD	PD		1.35/1.5/1.8	vdds_ddr1	No	LVC MOS DDR	Pux/PDy	



**Table 4-1. Pin Attributes<sup>(1)</sup> (continued)**

BALL NUMBER [1]	BALL NAME [2]	SIGNAL NAME [3]	PN [4]	MUXMODE [5]	TYPE [6]	BALL RESET STATE [7]	BALL RESET REL. STATE [8]	BALL RESET REL. MUXMODE [9]	I/O VOLTAGE VALUE [10]	POWER [11]	HYS [12]	BUFFER TYPE [13]	PULL UP/DOWN TYPE [14]	DSIS [15]
W23	ddr1_ecc_d3	ddr1_ecc_d3		0	IO	PD	PD		1.35/1.5/1.8	vdds_ddr1	No	LVC MOS DDR	Pux/PDy	
Y25	ddr1_ecc_d4	ddr1_ecc_d4		0	IO	PD	PD		1.35/1.5/1.8	vdds_ddr1	No	LVC MOS DDR	Pux/PDy	
V24	ddr1_ecc_d5	ddr1_ecc_d5		0	IO	PD	PD		1.35/1.5/1.8	vdds_ddr1	No	LVC MOS DDR	Pux/PDy	
V25	ddr1_ecc_d6	ddr1_ecc_d6		0	IO	PD	PD		1.35/1.5/1.8	vdds_ddr1	No	LVC MOS DDR	Pux/PDy	
Y26	ddr1_ecc_d7	ddr1_ecc_d7		0	IO	PD	PD		1.35/1.5/1.8	vdds_ddr1	No	LVC MOS DDR	Pux/PDy	
AH24	ddr1_nck	ddr1_nck		0	O	PD	drive clk (OFF)		1.35/1.5/1.8	vdds_ddr1	No	LVC MOS DDR	Pux/PDy	
AE20	ddr1_odt0	ddr1_odt0		0	O	PD	drive 0 (OFF)		1.35/1.5/1.8	vdds_ddr1	No	LVC MOS DDR	Pux/PDy	
AF20	ddr1_rasn	ddr1_rasn		0	O	PD	drive 1 (OFF)		1.35/1.5/1.8	vdds_ddr1	No	LVC MOS DDR	Pux/PDy	
AG21	ddr1_rst	ddr1_rst		0	O	PD	drive 0 (OFF)		1.35/1.5/1.8	vdds_ddr1	No	LVC MOS DDR	Pux/PDy	
Y18	ddr1_vref0	ddr1_vref0		0	PWR	OFF	OFF		1.35/1.5/1.8	vdds_ddr1	No	LVC MOS DDR		
AH21	ddr1_wen	ddr1_wen		0	O	PD	drive 1 (OFF)		1.35/1.5/1.8	vdds_ddr1	No	LVC MOS DDR	Pux/PDy	
R25	ddr2_a0	ddr2_a0		0	O	PD	drive 1 (OFF)		1.35/1.5/1.8	vdds_ddr2	No	LVC MOS DDR	Pux/PDy	
R26	ddr2_a1	ddr2_a1		0	O	PD	drive 1 (OFF)		1.35/1.5/1.8	vdds_ddr2	No	LVC MOS DDR	Pux/PDy	
R28	ddr2_a2	ddr2_a2		0	O	PD	drive 1 (OFF)		1.35/1.5/1.8	vdds_ddr2	No	LVC MOS DDR	Pux/PDy	
R27	ddr2_a3	ddr2_a3		0	O	PD	drive 1 (OFF)		1.35/1.5/1.8	vdds_ddr2	No	LVC MOS DDR	Pux/PDy	
P23	ddr2_a4	ddr2_a4		0	O	PD	drive 1 (OFF)		1.35/1.5/1.8	vdds_ddr2	No	LVC MOS DDR	Pux/PDy	
P22	ddr2_a5	ddr2_a5		0	O	PD	drive 1 (OFF)		1.35/1.5/1.8	vdds_ddr2	No	LVC MOS DDR	Pux/PDy	
P25	ddr2_a6	ddr2_a6		0	O	PD	drive 1 (OFF)		1.35/1.5/1.8	vdds_ddr2	No	LVC MOS DDR	Pux/PDy	
N20	ddr2_a7	ddr2_a7		0	O	PD	drive 1 (OFF)		1.35/1.5/1.8	vdds_ddr2	No	LVC MOS DDR	Pux/PDy	
P27	ddr2_a8	ddr2_a8		0	O	PD	drive 1 (OFF)		1.35/1.5/1.8	vdds_ddr2	No	LVC MOS DDR	Pux/PDy	
N27	ddr2_a9	ddr2_a9		0	O	PD	drive 1 (OFF)		1.35/1.5/1.8	vdds_ddr2	No	LVC MOS DDR	Pux/PDy	
N23	ddr2_a10	ddr2_a10		0	O	PD	drive 1 (OFF)		1.35/1.5/1.8	vdds_ddr2	No	LVC MOS DDR	Pux/PDy	
P26	ddr2_a11	ddr2_a11		0	O	PD	drive 1 (OFF)		1.35/1.5/1.8	vdds_ddr2	No	LVC MOS DDR	Pux/PDy	

**Table 4-1. Pin Attributes<sup>(1)</sup> (continued)**

BALL NUMBER [1]	BALL NAME [2]	SIGNAL NAME [3]	PN [4]	MUXMODE [5]	TYPE [6]	BALL RESET STATE [7]	BALL RESET REL. STATE [8]	BALL RESET REL. MUXMODE [9]	I/O VOLTAGE VALUE [10]	POWER [11]	HYS [12]	BUFFER TYPE [13]	PULL UP/DOWN TYPE [14]	DSIS [15]
N28	ddr2_a12	ddr2_a12		0	O	PD	drive 1 (OFF)		1.35/1.5/1.8	vdds_ddr2	No	LVC MOS DDR	Pux/PDy	
T22	ddr2_a13	ddr2_a13		0	O	PD	drive 1 (OFF)		1.35/1.5/1.8	vdds_ddr2	No	LVC MOS DDR	Pux/PDy	
R22	ddr2_a14	ddr2_a14		0	O	PD	drive 1 (OFF)		1.35/1.5/1.8	vdds_ddr2	No	LVC MOS DDR	Pux/PDy	
U22	ddr2_a15	ddr2_a15		0	O	PD	drive 1 (OFF)		1.35/1.5/1.8	vdds_ddr2	No	LVC MOS DDR	Pux/PDy	
U23	ddr2_ba0	ddr2_ba0		0	O	PD	drive 1 (OFF)		1.35/1.5/1.8	vdds_ddr2	No	LVC MOS DDR	Pux/PDy	
U27	ddr2_ba1	ddr2_ba1		0	O	PD	drive 1 (OFF)		1.35/1.5/1.8	vdds_ddr2	No	LVC MOS DDR	Pux/PDy	
U26	ddr2_ba2	ddr2_ba2		0	O	PD	drive 1 (OFF)		1.35/1.5/1.8	vdds_ddr2	No	LVC MOS DDR	Pux/PDy	
U28	ddr2_casn	ddr2_casn		0	O	PD	drive 1 (OFF)		1.35/1.5/1.8	vdds_ddr2	No	LVC MOS DDR	Pux/PDy	
T28	ddr2_ck	ddr2_ck		0	O	PD	drive clk (OFF)		1.35/1.5/1.8	vdds_ddr2	No	LVC MOS DDR	Pux/PDy	
U24	ddr2_cke	ddr2_cke		0	O	PD	drive 0 (OFF)		1.35/1.5/1.8	vdds_ddr2	No	LVC MOS DDR	Pux/PDy	
P24	ddr2_csn0	ddr2_csn0		0	O	PD	drive 1 (OFF)		1.35/1.5/1.8	vdds_ddr2	No	LVC MOS DDR	Pux/PDy	
E26	ddr2_d0	ddr2_d0		0	IO	PU	PU		1.35/1.5/1.8	vdds_ddr2	No	LVC MOS DDR	Pux/PDy	
G25	ddr2_d1	ddr2_d1		0	IO	PU	PU		1.35/1.5/1.8	vdds_ddr2	No	LVC MOS DDR	Pux/PDy	
F25	ddr2_d2	ddr2_d2		0	IO	PU	PU		1.35/1.5/1.8	vdds_ddr2	No	LVC MOS DDR	Pux/PDy	
F24	ddr2_d3	ddr2_d3		0	IO	PU	PU		1.35/1.5/1.8	vdds_ddr2	No	LVC MOS DDR	Pux/PDy	
F26	ddr2_d4	ddr2_d4		0	IO	PU	PU		1.35/1.5/1.8	vdds_ddr2	No	LVC MOS DDR	Pux/PDy	
F27	ddr2_d5	ddr2_d5		0	IO	PU	PU		1.35/1.5/1.8	vdds_ddr2	No	LVC MOS DDR	Pux/PDy	
E27	ddr2_d6	ddr2_d6		0	IO	PU	PU		1.35/1.5/1.8	vdds_ddr2	No	LVC MOS DDR	Pux/PDy	
E28	ddr2_d7	ddr2_d7		0	IO	PU	PU		1.35/1.5/1.8	vdds_ddr2	No	LVC MOS DDR	Pux/PDy	
H23	ddr2_d8	ddr2_d8		0	IO	PU	PU		1.35/1.5/1.8	vdds_ddr2	No	LVC MOS DDR	Pux/PDy	
H25	ddr2_d9	ddr2_d9		0	IO	PU	PU		1.35/1.5/1.8	vdds_ddr2	No	LVC MOS DDR	Pux/PDy	
H24	ddr2_d10	ddr2_d10		0	IO	PU	PU		1.35/1.5/1.8	vdds_ddr2	No	LVC MOS DDR	Pux/PDy	
H26	ddr2_d11	ddr2_d11		0	IO	PU	PU		1.35/1.5/1.8	vdds_ddr2	No	LVC MOS DDR	Pux/PDy	

**Table 4-1. Pin Attributes<sup>(1)</sup> (continued)**

BALL NUMBER [1]	BALL NAME [2]	SIGNAL NAME [3]	PN [4]	MUXMODE [5]	TYPE [6]	BALL RESET STATE [7]	BALL RESET REL. STATE [8]	BALL RESET REL. MUXMODE [9]	I/O VOLTAGE VALUE [10]	POWER [11]	HYS [12]	BUFFER TYPE [13]	PULL UP/DOWN TYPE [14]	DSIS [15]
G26	ddr2_d12	ddr2_d12		0	IO	PU	PU		1.35/1.5/1.8	vdds_ddr2	No	LVC MOS DDR	Pux/PDy	
J25	ddr2_d13	ddr2_d13		0	IO	PU	PU		1.35/1.5/1.8	vdds_ddr2	No	LVC MOS DDR	Pux/PDy	
J26	ddr2_d14	ddr2_d14		0	IO	PU	PU		1.35/1.5/1.8	vdds_ddr2	No	LVC MOS DDR	Pux/PDy	
J24	ddr2_d15	ddr2_d15		0	IO	PU	PU		1.35/1.5/1.8	vdds_ddr2	No	LVC MOS DDR	Pux/PDy	
L22	ddr2_d16	ddr2_d16		0	IO	PU	PU		1.35/1.5/1.8	vdds_ddr2	No	LVC MOS DDR	Pux/PDy	
K20	ddr2_d17	ddr2_d17		0	IO	PU	PU		1.35/1.5/1.8	vdds_ddr2	No	LVC MOS DDR	Pux/PDy	
K21	ddr2_d18	ddr2_d18		0	IO	PU	PU		1.35/1.5/1.8	vdds_ddr2	No	LVC MOS DDR	Pux/PDy	
L23	ddr2_d19	ddr2_d19		0	IO	PU	PU		1.35/1.5/1.8	vdds_ddr2	No	LVC MOS DDR	Pux/PDy	
L24	ddr2_d20	ddr2_d20		0	IO	PU	PU		1.35/1.5/1.8	vdds_ddr2	No	LVC MOS DDR	Pux/PDy	
J23	ddr2_d21	ddr2_d21		0	IO	PU	PU		1.35/1.5/1.8	vdds_ddr2	No	LVC MOS DDR	Pux/PDy	
K22	ddr2_d22	ddr2_d22		0	IO	PU	PU		1.35/1.5/1.8	vdds_ddr2	No	LVC MOS DDR	Pux/PDy	
J20	ddr2_d23	ddr2_d23		0	IO	PU	PU		1.35/1.5/1.8	vdds_ddr2	No	LVC MOS DDR	Pux/PDy	
L27	ddr2_d24	ddr2_d24		0	IO	PU	PU		1.35/1.5/1.8	vdds_ddr2	No	LVC MOS DDR	Pux/PDy	
L26	ddr2_d25	ddr2_d25		0	IO	PU	PU		1.35/1.5/1.8	vdds_ddr2	No	LVC MOS DDR	Pux/PDy	
L25	ddr2_d26	ddr2_d26		0	IO	PU	PU		1.35/1.5/1.8	vdds_ddr2	No	LVC MOS DDR	Pux/PDy	
L28	ddr2_d27	ddr2_d27		0	IO	PU	PU		1.35/1.5/1.8	vdds_ddr2	No	LVC MOS DDR	Pux/PDy	
M23	ddr2_d28	ddr2_d28		0	IO	PU	PU		1.35/1.5/1.8	vdds_ddr2	No	LVC MOS DDR	Pux/PDy	
M24	ddr2_d29	ddr2_d29		0	IO	PU	PU		1.35/1.5/1.8	vdds_ddr2	No	LVC MOS DDR	Pux/PDy	
M25	ddr2_d30	ddr2_d30		0	IO	PU	PU		1.35/1.5/1.8	vdds_ddr2	No	LVC MOS DDR	Pux/PDy	
M26	ddr2_d31	ddr2_d31		0	IO	PU	PU		1.35/1.5/1.8	vdds_ddr2	No	LVC MOS DDR	Pux/PDy	
F28	ddr2_dqm0	ddr2_dqm0		0	O	PU	PU		1.35/1.5/1.8	vdds_ddr2	No	LVC MOS DDR	Pux/PDy	
G24	ddr2_dqm1	ddr2_dqm1		0	O	PU	PU		1.35/1.5/1.8	vdds_ddr2	No	LVC MOS DDR	Pux/PDy	
K23	ddr2_dqm2	ddr2_dqm2		0	O	PU	PU		1.35/1.5/1.8	vdds_ddr2	No	LVC MOS DDR	Pux/PDy	

**Table 4-1. Pin Attributes<sup>(1)</sup> (continued)**

BALL NUMBER [1]	BALL NAME [2]	SIGNAL NAME [3]	PN [4]	MUXMODE [5]	TYPE [6]	BALL RESET STATE [7]	BALL RESET REL. STATE [8]	BALL RESET REL. MUXMODE [9]	I/O VOLTAGE VALUE [10]	POWER [11]	HYS [12]	BUFFER TYPE [13]	PULL UP/DOWN TYPE [14]	DSIS [15]
M22	ddr2_dqm3	ddr2_dqm3		0	O	PU	PU		1.35/1.5/1.8	vdds_ddr2	No	LVC MOS DDR	Pux/PDy	
G28	ddr2_dqs0	ddr2_dqs0		0	IO	PD	PD		1.35/1.5/1.8	vdds_ddr2		LVC MOS DDR	Pux/PDy	
H27	ddr2_dqs1	ddr2_dqs1		0	IO	PD	PD		1.35/1.5/1.8	vdds_ddr2		LVC MOS DDR	Pux/PDy	
K27	ddr2_dqs2	ddr2_dqs2		0	IO	PD	PD		1.35/1.5/1.8	vdds_ddr2		LVC MOS DDR	Pux/PDy	
M28	ddr2_dqs3	ddr2_dqs3		0	IO	PD	PD		1.35/1.5/1.8	vdds_ddr2		LVC MOS DDR	Pux/PDy	
G27	ddr2_dqsn0	ddr2_dqsn0		0	IO	PU	PU		1.35/1.5/1.8	vdds_ddr2		LVC MOS DDR	Pux/PDy	
H28	ddr2_dqsn1	ddr2_dqsn1		0	IO	PU	PU		1.35/1.5/1.8	vdds_ddr2		LVC MOS DDR	Pux/PDy	
K28	ddr2_dqsn2	ddr2_dqsn2		0	IO	PU	PU		1.35/1.5/1.8	vdds_ddr2		LVC MOS DDR	Pux/PDy	
M27	ddr2_dqsn3	ddr2_dqsn3		0	IO	PU	PU		1.35/1.5/1.8	vdds_ddr2		LVC MOS DDR	Pux/PDy	
T27	ddr2_nck	ddr2_nck		0	O	PD	drive clk (OFF)		1.35/1.5/1.8	vdds_ddr2	No	LVC MOS DDR	Pux/PDy	
R23	ddr2_odt0	ddr2_odt0		0	O	PD	drive 0 (OFF)		1.35/1.5/1.8	vdds_ddr2	No	LVC MOS DDR	Pux/PDy	
T23	ddr2_rasn	ddr2_rasn		0	O	PD	drive 1 (OFF)		1.35/1.5/1.8	vdds_ddr2	No	LVC MOS DDR	Pux/PDy	
R24	ddr2_rst	ddr2_rst		0	O	PD	drive 0 (OFF)		1.35/1.5/1.8	vdds_ddr2	No	LVC MOS DDR	Pux/PDy	
N22	ddr2_vref0	ddr2_vref0		0	PWR	OFF	OFF		1.35/1.5/1.8	vdds_ddr2	No	LVC MOS DDR		
U25	ddr2_wen	ddr2_wen		0	O	PD	drive 1 (OFF)		1.35/1.5/1.8	vdds_ddr2	No	LVC MOS DDR	Pux/PDy	
G21	emu0	emu0		0	IO	PU	PU	0	1.8/3.3	vddshv3	Yes	Dual Voltage LVC MOS	PU/PD	
		gpio8_30		14	IO									
D24	emu1	emu1		0	IO	PU	PU	0	1.8/3.3	vddshv3	Yes	Dual Voltage LVC MOS	PU/PD	
		gpio8_31		14	IO									

Table 4-1. Pin Attributes<sup>(1)</sup> (continued)

BALL NUMBER [1]	BALL NAME [2]	SIGNAL NAME [3]	PN [4]	MUXMODE [5]	TYPE [6]	BALL RESET STATE [7]	BALL RESET REL. STATE [8]	BALL RESET REL. MUXMODE [9]	I/O VOLTAGE VALUE [10]	POWER [11]	HYS [12]	BUFFER TYPE [13]	PULL UP/DOWN TYPE [14]	DSIS [15]		
AC5	gpio6_10	gpio6_10		0	IO	PU	PU	15	1.8/3.3	vddshv7	Yes	Dual Voltage LVCMOS	PU/PD			
		mdio_mclk		1	O										1	
		i2c3_sda		2	IO											1
		vin2b_hsync1		4	I											
		ehrpwm2A		10	O											
		pr2_mii_mt1_clk		11	I											0
		pr2_pru0_gpi0		12	I											
		pr2_pru0_gpo0		13	O											
		Driver off		15	I											
AB4	gpio6_11	gpio6_11		0	IO	PU	PU	15	1.8/3.3	vddshv7	Yes	Dual Voltage LVCMOS	PU/PD			
		mdio_d		1	IO											1
		i2c3_scl		2	IO											1
		vin2b_vsync1		4	I											
		ehrpwm2B		10	O											
		pr2_mii1_txen		11	O											
		pr2_pru0_gpi1		12	I											
		pr2_pru0_gpo1		13	O											
		Driver off		15	I											
E21	gpio6_14	gpio6_14		0	IO	PU	PU	15	1.8/3.3	vddshv3	Yes	Dual Voltage LVCMOS	PU/PD			
		mcasp1_axr8		1	IO											0
		dcan2_tx		2	IO											
		mcan_tx		3	I											1
		uart10_rxd		3	I											
		vout2_hsync	No	6	O											
		vin4a_hsync0		8	I											0
		i2c3_sda		9	IO											1
		timer1		10	IO											
Driver off		15	I													

Table 4-1. Pin Attributes<sup>(1)</sup> (continued)

BALL NUMBER [1]	BALL NAME [2]	SIGNAL NAME [3]	PN [4]	MUXMODE [5]	TYPE [6]	BALL RESET STATE [7]	BALL RESET REL. STATE [8]	BALL RESET REL. MUXMODE [9]	I/O VOLTAGE VALUE [10]	POWER [11]	HYS [12]	BUFFER TYPE [13]	PULL UP/DOWN TYPE [14]	DSIS [15]
F20	gpio6_15	gpio6_15		0	IO	PU	PU	15	1.8/3.3	vddshv3	Yes	Dual Voltage LVCMOS	PU/PD	
		mcasep1_axr9		1	IO									0
		dcan2_rx mcan_rx		2	IO									
		uart10_txd		3	O									
		vout2_vsync	No	6	O									
		vin4a_vsync0		8	I									0
		i2c3_scl		9	IO									1
		timer2		10	IO									
		gpio6_15		14	IO									
		Driver off		15	I									
F21	gpio6_16	gpio6_16		0	IO	PU	PU	15	1.8/3.3	vddshv3	Yes	Dual Voltage LVCMOS	PU/PD	
		mcasep1_axr10		1	IO									0
		vout2_fld	No	6	O									
		vin4a_fld0		8	I									0
		clkout1		9	O									
		timer3		10	IO									
		gpio6_16		14	IO									
		Driver off		15	I									
R6	gpmc_a0	gpmc_a0		0	O	PD	PD	15	1.8/3.3	vddshv10	Yes	Dual Voltage LVCMOS	PU/PD	
		vin3a_d16		2	I									0
		vout3_d16	No	3	O									
		vin4a_d0		4	I									0
		vin4b_d0		6	I									0
		i2c4_scl		7	IO									1
		uart5_rxd		8	I									1
		gpio7_3 gpmc_a26 gpmc_a16		14	IO									
		Driver off		15	I									

Table 4-1. Pin Attributes<sup>(1)</sup> (continued)

BALL NUMBER [1]	BALL NAME [2]	SIGNAL NAME [3]	PN [4]	MUXMODE [5]	TYPE [6]	BALL RESET STATE [7]	BALL RESET REL. STATE [8]	BALL RESET REL. MUXMODE [9]	I/O VOLTAGE VALUE [10]	POWER [11]	HYS [12]	BUFFER TYPE [13]	PULL UP/DOWN TYPE [14]	DSIS [15]
T9	gpmc_a1	gpmc_a1		0	O	PD	PD	15	1.8/3.3	vddshv10	Yes	Dual Voltage LVCMOS	PU/PD	
		vin3a_d17		2	I									0
		vout3_d17	No	3	O									
		vin4a_d1		4	I									0
		vin4b_d1		6	I									0
		i2c4_sda		7	IO									1
		uart5_txd		8	O									
		gpio7_4		14	IO									
Driver off		15	I											
T6	gpmc_a2	gpmc_a2		0	O	PD	PD	15	1.8/3.3	vddshv10	Yes	Dual Voltage LVCMOS	PU/PD	
		vin3a_d18		2	I									0
		vout3_d18	No	3	O									
		vin4a_d2		4	I									0
		vin4b_d2		6	I									0
		uart7_rxd		7	I									1
		uart5_ctsn		8	I									1
		gpio7_5		14	IO									
Driver off		15	I											
T7	gpmc_a3	gpmc_a3		0	O	PD	PD	15	1.8/3.3	vddshv10	Yes	Dual Voltage LVCMOS	PU/PD	
		qspi1_cs2		1	O									1
		vin3a_d19		2	I									0
		vout3_d19	No	3	O									
		vin4a_d3		4	I									0
		vin4b_d3		6	I									0
		uart7_txd		7	O									
		uart5_rtsn		8	O									
gpio7_6		14	IO											
Driver off		15	I											

Table 4-1. Pin Attributes<sup>(1)</sup> (continued)

BALL NUMBER [1]	BALL NAME [2]	SIGNAL NAME [3]	PN [4]	MUXMODE [5]	TYPE [6]	BALL RESET STATE [7]	BALL RESET REL. STATE [8]	BALL RESET REL. MUXMODE [9]	I/O VOLTAGE VALUE [10]	POWER [11]	HYS [12]	BUFFER TYPE [13]	PULL UP/DOWN TYPE [14]	DSIS [15]	
P6	gpmc_a4	gpmc_a4		0	O	PD	PD	15	1.8/3.3	vddshv10	Yes	Dual Voltage LVCMOS	PU/PD		
		qspi1_cs3		1	O										1
		vin3a_d20		2	I										0
		vout3_d20	No	3	O										0
		vin4a_d4		4	I										0
		vin4b_d4		6	I										0
		i2c5_scl		7	IO										1
		uart6_rxd		8	I										1
		gpio1_26		14	IO										
	Driver off		15	I											
R9	gpmc_a5	gpmc_a5		0	O	PD	PD	15	1.8/3.3	vddshv10	Yes	Dual Voltage LVCMOS	PU/PD		
		vin3a_d21		2	I										0
		vout3_d21	No	3	O										0
		vin4a_d5		4	I										0
		vin4b_d5		6	I										0
		i2c5_sda		7	IO										1
		uart6_txd		8	O										
		gpio1_27		14	IO										
			Driver off		15	I									
R5	gpmc_a6	gpmc_a6		0	O	PD	PD	15	1.8/3.3	vddshv10	Yes	Dual Voltage LVCMOS	PU/PD		
		vin3a_d22		2	I										0
		vout3_d22	No	3	O										0
		vin4a_d6		4	I										0
		vin4b_d6		6	I										0
		uart8_rxd		7	I										1
		uart6_ctsn		8	I										1
		gpio1_28		14	IO										
			Driver off		15	I									
P5	gpmc_a7	gpmc_a7		0	O	PD	PD	15	1.8/3.3	vddshv10	Yes	Dual Voltage LVCMOS	PU/PD		
		vin3a_d23		2	I										0
		vout3_d23	No	3	O										0
		vin4a_d7		4	I										0
		vin4b_d7		6	I										0
		uart8_txd		7	O										
		uart6_rtsn		8	O										
		gpio1_29		14	IO										
			Driver off		15	I									



Table 4-1. Pin Attributes<sup>(1)</sup> (continued)

BALL NUMBER [1]	BALL NAME [2]	SIGNAL NAME [3]	PN [4]	MUXMODE [5]	TYPE [6]	BALL RESET STATE [7]	BALL RESET REL. STATE [8]	BALL RESET REL. MUXMODE [9]	I/O VOLTAGE VALUE [10]	POWER [11]	HYS [12]	BUFFER TYPE [13]	PULL UP/DOWN TYPE [14]	DSIS [15]
N7	gpmc_a8	gpmc_a8		0	O	PD	PD	15	1.8/3.3	vddshv10	Yes	Dual Voltage LVCMOS	PU/PD	
		vin3a_hsync0		2	I									0
		vout3_hsync	No	3	O									
		vin4b_hsync1		6	I									0
		timer12		7	IO									
		spi4_sclk		8	IO									0
		gpio1_30		14	IO									
Driver off		15	I											
R4	gpmc_a9	gpmc_a9		0	O	PD	PD	15	1.8/3.3	vddshv10	Yes	Dual Voltage LVCMOS	PU/PD	
		vin3a_vsync0		2	I									0
		vout3_vsync	No	3	O									
		vin4b_vsync1		6	I									0
		timer11		7	IO									
		spi4_d1		8	IO									0
		gpio1_31		14	IO									
Driver off		15	I											
N9	gpmc_a10	gpmc_a10		0	O	PD	PD	15	1.8/3.3	vddshv10	Yes	Dual Voltage LVCMOS	PU/PD	
		vin3a_de0		2	I									0
		vout3_de	No	3	O									
		vin4b_clk1		6	I									0
		timer10		7	IO									
		spi4_d0		8	IO									0
		gpio2_0		14	IO									
Driver off		15	I											
P9	gpmc_a11	gpmc_a11		0	O	PD	PD	15	1.8/3.3	vddshv10	Yes	Dual Voltage LVCMOS	PU/PD	
		vin3a_fld0		2	I									0
		vout3_fld	No	3	O									
		vin4a_fld0		4	I									0
		vin4b_de1		6	I									0
		timer9		7	IO									
		spi4_cs0		8	IO									1
		gpio2_1		14	IO									
Driver off		15	I											

Table 4-1. Pin Attributes<sup>(1)</sup> (continued)

BALL NUMBER [1]	BALL NAME [2]	SIGNAL NAME [3]	PN [4]	MUXMODE [5]	TYPE [6]	BALL RESET STATE [7]	BALL RESET REL. STATE [8]	BALL RESET REL. MUXMODE [9]	I/O VOLTAGE VALUE [10]	POWER [11]	HYS [12]	BUFFER TYPE [13]	PULL UP/DOWN TYPE [14]	DSIS [15]
P4	gpmc_a12	gpmc_a12		0	O	PD	PD	15	1.8/3.3	vddshv10	Yes	Dual Voltage LVCMOS	PU/PD	
		vin4a_clk0		4	I									0
		gpmc_a0		5	O									
		vin4b_fld1		6	I									0
		timer8		7	IO									
		spi4_cs1		8	IO									1
		dma_evt1		9	I									0
		gpio2_2		14	IO									
Driver off		15	I											
R3	gpmc_a13	gpmc_a13		0	O	PD	PD	15	1.8/3.3	vddshv10	Yes	Dual Voltage LVCMOS	PU/PD	
		qspi1_rclk		1	I									0
		vin4a_hsync0		4	I									0
		timer7		7	IO									
		spi4_cs2		8	IO									1
		dma_evt2		9	I									0
		gpio2_3		14	IO									
		Driver off		15	I									
T2	gpmc_a14	gpmc_a14		0	O	PD	PD	15	1.8/3.3	vddshv10	Yes	Dual Voltage LVCMOS	PU/PD	
		qspi1_d3		1	I									0
		vin4a_vsync0		4	I									0
		timer6		7	IO									
		spi4_cs3		8	IO									1
		gpio2_4		14	IO									
		Driver off		15	I									
		U2	gpmc_a15	gpmc_a15		0	O	PD	PD	15	1.8/3.3			vddshv10
qspi1_d2				1	I							0		
vin4a_d8				4	I							0		
timer5				7	IO									
gpio2_5				14	IO									
Driver off				15	I									
U1	gpmc_a16	gpmc_a16		0	O	PD	PD	15	1.8/3.3	vddshv10	Yes	Dual Voltage LVCMOS	PU/PD	
		qspi1_d0		1	IO									0
		vin4a_d9		4	I									0
		gpio2_6		14	IO									
		Driver off		15	I									

**Table 4-1. Pin Attributes<sup>(1)</sup> (continued)**

BALL NUMBER [1]	BALL NAME [2]	SIGNAL NAME [3]	PN [4]	MUXMODE [5]	TYPE [6]	BALL RESET STATE [7]	BALL RESET REL. STATE [8]	BALL RESET REL. MUXMODE [9]	I/O VOLTAGE VALUE [10]	POWER [11]	HYS [12]	BUFFER TYPE [13]	PULL UP/DOWN TYPE [14]	DSIS [15]
P3	gpmc_a17	gpmc_a17		0	O	PD	PD	15	1.8/3.3	vddshv10	Yes	Dual Voltage LVCMOS	PU/PD	
		qspi1_d1		1	I									0
		vin4a_d10		4	I									0
		gpio2_7		14	IO									
		Driver off		15	I									
R2	gpmc_a18	gpmc_a18		0	O	PD	PD	15	1.8/3.3	vddshv10	Yes	Dual Voltage LVCMOS	PU/PD	
		qspi1_sclk		1	O									0
		vin4a_d11		4	I									
		gpio2_8		14	IO									
		Driver off		15	I									
K7 <sup>(9)</sup>	gpmc_a19	gpmc_a19		0	O	PD	PD	15	1.8/3.3	vddshv11	Yes	Dual Voltage LVCMOS	PU/PD	
		mmc2_dat4		1	IO									1
		gpmc_a13		2	O									
		vin4a_d12		4	I									0
		vin3b_d0		6	I									0
		gpio2_9		14	IO									
		Driver off		15	I									
M7 <sup>(9)</sup>	gpmc_a20	gpmc_a20		0	O	PD	PD	15	1.8/3.3	vddshv11	Yes	Dual Voltage LVCMOS	PU/PD	
		mmc2_dat5		1	IO									1
		gpmc_a14		2	O									
		vin4a_d13		4	I									0
		vin3b_d1		6	I									0
		gpio2_10		14	IO									
		Driver off		15	I									
J5 <sup>(9)</sup>	gpmc_a21	gpmc_a21		0	O	PD	PD	15	1.8/3.3	vddshv11	Yes	Dual Voltage LVCMOS	PU/PD	
		mmc2_dat6		1	IO									1
		gpmc_a15		2	O									
		vin4a_d14		4	I									0
		vin3b_d2		6	I									0
		gpio2_11		14	IO									
		Driver off		15	I									

Table 4-1. Pin Attributes<sup>(1)</sup> (continued)

BALL NUMBER [1]	BALL NAME [2]	SIGNAL NAME [3]	PN [4]	MUXMODE [5]	TYPE [6]	BALL RESET STATE [7]	BALL RESET REL. STATE [8]	BALL RESET REL. MUXMODE [9]	I/O VOLTAGE VALUE [10]	POWER [11]	HYS [12]	BUFFER TYPE [13]	PULL UP/DOWN TYPE [14]	DSIS [15]
K6 <sup>(9)</sup>	gpmc_a22	gpmc_a22		0	O	PD	PD	15	1.8/3.3	vddshv11	Yes	Dual Voltage LVCMOS	PU/PD	
		mmc2_dat7		1	IO									1
		gpmc_a16		2	O									
		vin4a_d15		4	I									0
		vin3b_d3		6	I									0
		gpio2_12		14	IO									
		Driver off		15	I									
J7	gpmc_a23	gpmc_a23		0	O	PD	PD	15	1.8/3.3	vddshv11	Yes	Dual Voltage LVCMOS	PU/PD	
		mmc2_clk		1	IO									1
		gpmc_a17		2	O									
		vin4a_fld0		4	I									0
		vin3b_d4		6	I									0
		gpio2_13		14	IO									
		Driver off		15	I									
J4 <sup>(9)</sup>	gpmc_a24	gpmc_a24		0	O	PD	PD	15	1.8/3.3	vddshv11	Yes	Dual Voltage LVCMOS	PU/PD	
		mmc2_dat0		1	IO									1
		gpmc_a18		2	O									
		vin3b_d5		6	I									0
		gpio2_14		14	IO									
		Driver off		15	I									
J6 <sup>(9)</sup>	gpmc_a25	gpmc_a25		0	O	PD	PD	15	1.8/3.3	vddshv11	Yes	Dual Voltage LVCMOS	PU/PD	
		mmc2_dat1		1	IO									1
		gpmc_a19		2	O									
		vin3b_d6		6	I									0
		gpio2_15		14	IO									
		Driver off		15	I									
H4 <sup>(9)</sup>	gpmc_a26	gpmc_a26		0	O	PD	PD	15	1.8/3.3	vddshv11	Yes	Dual Voltage LVCMOS	PU/PD	
		mmc2_dat2		1	IO									1
		gpmc_a20		2	O									
		vin3b_d7		6	I									0
		gpio2_16		14	IO									
		Driver off		15	I									

Table 4-1. Pin Attributes<sup>(1)</sup> (continued)

BALL NUMBER [1]	BALL NAME [2]	SIGNAL NAME [3]	PN [4]	MUXMODE [5]	TYPE [6]	BALL RESET STATE [7]	BALL RESET REL. STATE [8]	BALL RESET REL. MUXMODE [9]	I/O VOLTAGE VALUE [10]	POWER [11]	HYS [12]	BUFFER TYPE [13]	PULL UP/DOWN TYPE [14]	DSIS [15]	
H5 <sup>(9)</sup>	gpmc_a27	gpmc_a27		0	O	PD	PD	15	1.8/3.3	vddshv11	Yes	Dual Voltage LVCMOS	PU/PD		
		mmc2_dat3		1	IO									1	
		gpmc_a21		2	O										
		vin3b_hsync1		6	I										0
		gpio2_17		14	IO										
		Driver off		15	I										
M6	gpmc_ad0	gpmc_ad0		0	IO	OFF	OFF	15	1.8/3.3	vddshv10	Yes	Dual Voltage LVCMOS	PU/PD	0	
		vin3a_d0		2	I									0	
		vout3_d0	No	3	O										
		gpio1_6		14	IO										
		sysboot0		15	I										
M2	gpmc_ad1	gpmc_ad1		0	IO	OFF	OFF	15	1.8/3.3	vddshv10	Yes	Dual Voltage LVCMOS	PU/PD	0	
		vin3a_d1		2	I									0	
		vout3_d1	No	3	O										
		gpio1_7		14	IO										
		sysboot1		15	I										
L5	gpmc_ad2	gpmc_ad2		0	IO	OFF	OFF	15	1.8/3.3	vddshv10	Yes	Dual Voltage LVCMOS	PU/PD	0	
		vin3a_d2		2	I									0	
		vout3_d2	No	3	O										
		gpio1_8		14	IO										
		sysboot2		15	I										
M1	gpmc_ad3	gpmc_ad3		0	IO	OFF	OFF	15	1.8/3.3	vddshv10	Yes	Dual Voltage LVCMOS	PU/PD	0	
		vin3a_d3		2	I									0	
		vout3_d3	No	3	O										
		gpio1_9		14	IO										
		sysboot3		15	I										
L6	gpmc_ad4	gpmc_ad4		0	IO	OFF	OFF	15	1.8/3.3	vddshv10	Yes	Dual Voltage LVCMOS	PU/PD	0	
		vin3a_d4		2	I									0	
		vout3_d4	No	3	O										
		gpio1_10		14	IO										
		sysboot4		15	I										
L4	gpmc_ad5	gpmc_ad5		0	IO	OFF	OFF	15	1.8/3.3	vddshv10	Yes	Dual Voltage LVCMOS	PU/PD	0	
		vin3a_d5		2	I									0	
		vout3_d5	No	3	O										
		gpio1_11		14	IO										
		sysboot5		15	I										

Table 4-1. Pin Attributes<sup>(1)</sup> (continued)

BALL NUMBER [1]	BALL NAME [2]	SIGNAL NAME [3]	PN [4]	MUXMODE [5]	TYPE [6]	BALL RESET STATE [7]	BALL RESET REL. STATE [8]	BALL RESET REL. MUXMODE [9]	I/O VOLTAGE VALUE [10]	POWER [11]	HYS [12]	BUFFER TYPE [13]	PULL UP/DOWN TYPE [14]	DSIS [15]
L3	gpmc_ad6	gpmc_ad6		0	IO	OFF	OFF	15	1.8/3.3	vddshv10	Yes	Dual Voltage LVCMOS	PU/PD	0
		vin3a_d6		2	I									0
		vout3_d6	No	3	O									
		gpio1_12		14	IO									
		sysboot6		15	I									
L2	gpmc_ad7	gpmc_ad7		0	IO	OFF	OFF	15	1.8/3.3	vddshv10	Yes	Dual Voltage LVCMOS	PU/PD	0
		vin3a_d7		2	I									0
		vout3_d7	No	3	O									
		gpio1_13		14	IO									
		sysboot7		15	I									
L1	gpmc_ad8	gpmc_ad8		0	IO	OFF	OFF	15	1.8/3.3	vddshv10	Yes	Dual Voltage LVCMOS	PU/PD	0
		vin3a_d8		2	I									0
		vout3_d8	No	3	O									
		gpio7_18		14	IO									
		sysboot8		15	I									
K2	gpmc_ad9	gpmc_ad9		0	IO	OFF	OFF	15	1.8/3.3	vddshv10	Yes	Dual Voltage LVCMOS	PU/PD	0
		vin3a_d9		2	I									0
		vout3_d9	No	3	O									
		gpio7_19		14	IO									
		sysboot9		15	I									
J1	gpmc_ad10	gpmc_ad10		0	IO	OFF	OFF	15	1.8/3.3	vddshv10	Yes	Dual Voltage LVCMOS	PU/PD	0
		vin3a_d10		2	I									0
		vout3_d10	No	3	O									
		gpio7_28		14	IO									
		sysboot10		15	I									
J2	gpmc_ad11	gpmc_ad11		0	IO	OFF	OFF	15	1.8/3.3	vddshv10	Yes	Dual Voltage LVCMOS	PU/PD	0
		vin3a_d11		2	I									0
		vout3_d11	No	3	O									
		gpio7_29		14	IO									
		sysboot11		15	I									
H1	gpmc_ad12	gpmc_ad12		0	IO	OFF	OFF	15	1.8/3.3	vddshv10	Yes	Dual Voltage LVCMOS	PU/PD	0
		vin3a_d12		2	I									0
		vout3_d12	No	3	O									
		gpio1_18		14	IO									
		sysboot12		15	I									

Table 4-1. Pin Attributes<sup>(1)</sup> (continued)

BALL NUMBER [1]	BALL NAME [2]	SIGNAL NAME [3]	PN [4]	MUXMODE [5]	TYPE [6]	BALL RESET STATE [7]	BALL RESET REL. STATE [8]	BALL RESET REL. MUXMODE [9]	I/O VOLTAGE VALUE [10]	POWER [11]	HYS [12]	BUFFER TYPE [13]	PULL UP/DOWN TYPE [14]	DSIS [15]
J3	gpmc_ad13	gpmc_ad13		0	IO	OFF	OFF	15	1.8/3.3	vddshv10	Yes	Dual Voltage LVCMOS	PU/PD	0
		vin3a_d13		2	I									0
		vout3_d13	No	3	O									
		gpio1_19		14	IO									
		sysboot13		15	I									
H2	gpmc_ad14	gpmc_ad14		0	IO	OFF	OFF	15	1.8/3.3	vddshv10	Yes	Dual Voltage LVCMOS	PU/PD	0
		vin3a_d14		2	I									0
		vout3_d14	No	3	O									
		gpio1_20		14	IO									
		sysboot14		15	I									
H3	gpmc_ad15	gpmc_ad15		0	IO	OFF	OFF	15	1.8/3.3	vddshv10	Yes	Dual Voltage LVCMOS	PU/PD	0
		vin3a_d15		2	I									0
		vout3_d15	No	3	O									
		gpio1_21		14	IO									
		sysboot15		15	I									
N1	gpmc_advn_ale	gpmc_advn_ale		0	O	PU	PU	15	1.8/3.3	vddshv10	Yes	Dual Voltage LVCMOS	PU/PD	
		gpmc_cs6		1	O									
		clkout2		2	O									
		gpmc_wait1		3	I									1
		vin4a_vsync0		4	I									0
		gpmc_a2		5	O									
		gpmc_a23		6	O									
		timer3		7	IO									
		i2c3_sda		8	IO									1
		dma_evt2		9	I									0
		gpio2_23		14	IO									
		gpmc_a19												
		Driver off		15	I									
N6	gpmc_ben0	gpmc_ben0		0	O	PU	PU	15	1.8/3.3	vddshv10	Yes	Dual Voltage LVCMOS	PU/PD	
		gpmc_cs4		1	O									
		vin1b_hsync1		3	I									0
		vin3b_de1		6	I									0
		timer2		7	IO									
		dma_evt3		9	I									0
		gpio2_26		14	IO									
		gpmc_a21												
		Driver off		15	I									

**Table 4-1. Pin Attributes<sup>(1)</sup> (continued)**

BALL NUMBER [1]	BALL NAME [2]	SIGNAL NAME [3]	PN [4]	MUXMODE [5]	TYPE [6]	BALL RESET STATE [7]	BALL RESET REL. STATE [8]	BALL RESET REL. MUXMODE [9]	I/O VOLTAGE VALUE [10]	POWER [11]	HYS [12]	BUFFER TYPE [13]	PULL UP/DOWN TYPE [14]	DSIS [15]										
M4	gpmc_ben1	gpmc_ben1		0	O	PU	PU	15	1.8/3.3	vddshv10	Yes	Dual Voltage LVCMOS	PU/PD											
		gpmc_cs5		1	O																			
		vin1b_de1		3	I									0										
		vin3b_clk1		4	I									0										
		gpmc_a3		5	O																			
		vin3b_fld1		6	I									0										
		timer1		7	IO																			
		dma_evt4		9	I									0										
		gpio2_27 gpmc_a22 Driver off		14 15	IO I																			
P7	gpmc_clk	gpmc_clk		0	IO	PU	PU	15	1.8/3.3	vddshv10	Yes	Dual Voltage LVCMOS	PU/PD	0										
		gpmc_cs7		1	O																			
		clkout1		2	O																			
		gpmc_wait1		3	I									1										
		vin4a_hsync0		4	I									0										
		vin4a_de0		5	I									0										
		vin3b_clk1		6	I									0										
		timer4		7	IO																			
		i2c3_scl		8	IO									1										
		dma_evt1		9	I									0										
		gpio2_22 gpmc_a20 Driver off		14 15	IO I																			
		T1	gpmc_cs0	gpmc_cs0										0	O	PU	PU	15	1.8/3.3	vddshv10	Yes	Dual Voltage LVCMOS	PU/PD	
				gpio2_19										14	IO									
				Driver off										15	I									
H6	gpmc_cs1	gpmc_cs1		0	O	PU	PU	15	1.8/3.3	vddshv11	Yes	Dual Voltage LVCMOS	PU/PD											
		mmc2_cmd		1	IO									1										
		gpmc_a22		2	O																			
		vin4a_de0		4	I									0										
		vin3b_vsync1		6	I									0										
		gpio2_18		14	IO																			
		Driver off		15	I																			



**Table 4-1. Pin Attributes<sup>(1)</sup> (continued)**

BALL NUMBER [1]	BALL NAME [2]	SIGNAL NAME [3]	PN [4]	MUXMODE [5]	TYPE [6]	BALL RESET STATE [7]	BALL RESET REL. STATE [8]	BALL RESET REL. MUXMODE [9]	I/O VOLTAGE VALUE [10]	POWER [11]	HYS [12]	BUFFER TYPE [13]	PULL UP/DOWN TYPE [14]	DSIS [15]
P2	gpmc_cs2	gpmc_cs2		0	O	PU	PU	15	1.8/3.3	vddshv10	Yes	Dual Voltage LVCMOS	PU/PD	
		qspi1_cs0		1	O									1
		gpio2_20 gpmc_a23 gpmc_a13		14	IO									
		Driver off		15	I									
P1	gpmc_cs3	gpmc_cs3		0	O	PU	PU	15	1.8/3.3	vddshv10	Yes	Dual Voltage LVCMOS	PU/PD	
		qspi1_cs1		1	O									1
		vin3a_clk0		2	I									0
		vout3_clk	No	3	O									
		gpmc_a1		5	O									
		gpio2_21 gpmc_a24 gpmc_a14		14	IO									
		Driver off		15	I									
M5	gpmc_oen_ren	gpmc_oen_ren		0	O	PU	PU	15	1.8/3.3	vddshv10	Yes	Dual Voltage LVCMOS	PU/PD	
		gpio2_24		14	IO									
		Driver off		15	I									
N2	gpmc_wait0	gpmc_wait0		0	I	PU	PU	15	1.8/3.3	vddshv10	Yes	Dual Voltage LVCMOS	PU/PD	1
		gpio2_28 gpmc_a25 gpmc_a15		14	IO									
		Driver off		15	I									
M3	gpmc_wen	gpmc_wen		0	O	PU	PU	15	1.8/3.3	vddshv10	Yes	Dual Voltage LVCMOS	PU/PD	
		gpio2_25		14	IO									
		Driver off		15	I									
AG16	hdmi1_clockx	hdmi1_clockx	No	0	O				1.8	vdda_hdmi		HDMIPHY	PDy	
AH16	hdmi1_clocky	hdmi1_clocky	No	0	O				1.8	vdda_hdmi		HDMIPHY	PDy	
AG17	hdmi1_data0x	hdmi1_data0x	No	0	O				1.8	vdda_hdmi		HDMIPHY	PDy	
AH17	hdmi1_data0y	hdmi1_data0y	No	0	O				1.8	vdda_hdmi		HDMIPHY	PDy	
AG18	hdmi1_data1x	hdmi1_data1x	No	0	O				1.8	vdda_hdmi		HDMIPHY	PDy	
AH18	hdmi1_data1y	hdmi1_data1y	No	0	O				1.8	vdda_hdmi		HDMIPHY	PDy	
AG19	hdmi1_data2x	hdmi1_data2x	No	0	O				1.8	vdda_hdmi		HDMIPHY	PDy	
AH19	hdmi1_data2y	hdmi1_data2y	No	0	O				1.8	vdda_hdmi		HDMIPHY	PDy	
C20	i2c1_scl	i2c1_scl		0	IO	OFF	OFF		1.8/3.3	vddshv3	Yes	Dual Voltage LVCMOS I2C	PU/PD	
C21	i2c1_sda	i2c1_sda		0	IO	OFF	OFF		1.8/3.3	vddshv3	Yes	Dual Voltage LVCMOS I2C	PU/PD	

Table 4-1. Pin Attributes<sup>(1)</sup> (continued)

BALL NUMBER [1]	BALL NAME [2]	SIGNAL NAME [3]	PN [4]	MUXMODE [5]	TYPE [6]	BALL RESET STATE [7]	BALL RESET REL. STATE [8]	BALL RESET REL. MUXMODE [9]	I/O VOLTAGE VALUE [10]	POWER [11]	HYS [12]	BUFFER TYPE [13]	PULL UP/DOWN TYPE [14]	DSIS [15]
F17	i2c2_scl	i2c2_scl		0	IO	OFF	OFF	15	1.8/3.3	vddshv3	Yes	Dual Voltage LVCMOS I2C	PU/PD	1
		hdmi1_ddc_sda	No	1	IO									
		Driver off		15	I									
C25	i2c2_sda	i2c2_sda		0	IO	OFF	OFF	15	1.8/3.3	vddshv3	Yes	Dual Voltage LVCMOS I2C	PU/PD	1
		hdmi1_ddc_scl	No	1	IO									
		Driver off		15	I									
AH15	ljcb_clkn	ljcb_clkn		0	IO				1.8	vdda_pcie		LJCB		
AG15	ljcb_clkp	ljcb_clkp		0	IO				1.8	vdda_pcie		LJCB		
B14	mcasep1_aclkr	mcasep1_aclkr		0	IO	PD	PD	15	1.8/3.3	vddshv3	Yes	Dual Voltage LVCMOS	PU/PD	0
		mcasep7_axr2		1	IO									0
		vout2_d0	No	6	O									0
		vin4a_d0		8	I									0
		i2c4_sda		10	IO									1
		gpio5_0		14	IO									
C14	mcasep1_aclkx	mcasep1_aclkx		0	IO	PD	PD	15	1.8/3.3	vddshv3	Yes	Dual Voltage LVCMOS	PU/PD	0
		i2c3_sda		10	IO									1
		pr2_mdio_mdclk		11	O									
		pr2_pru1_gpi7		12	I									
		pr2_pru1_gpo7		13	O									
		gpio7_31		14	IO									
G12	mcasep1_axr0	mcasep1_axr0		0	IO	PD	PD	15	1.8/3.3	vddshv3	Yes	Dual Voltage LVCMOS	PU/PD	0
		uart6_rxd		3	I									1
		i2c5_sda		10	IO									1
		pr2_mii0_rxer		11	I									0
		pr2_pru1_gpi8		12	I									
		pr2_pru1_gpo8		13	O									
		gpio5_2		14	IO									
		Driver off		15	I									

Table 4-1. Pin Attributes<sup>(1)</sup> (continued)

BALL NUMBER [1]	BALL NAME [2]	SIGNAL NAME [3]	PN [4]	MUXMODE [5]	TYPE [6]	BALL RESET STATE [7]	BALL RESET REL. STATE [8]	BALL RESET REL. MUXMODE [9]	I/O VOLTAGE VALUE [10]	POWER [11]	HYS [12]	BUFFER TYPE [13]	PULL UP/DOWN TYPE [14]	DSIS [15]	
F12	mcasep1_axr1	mcasep1_axr1		0	IO	PD	PD	15	1.8/3.3	vddshv3	Yes	Dual Voltage LVCMOS	PU/PD	0	
		uart6_txd		3	O										
		i2c5_scl		10	IO										1
		pr2_mii_mt0_clk		11	I										0
		pr2_pru1_gpi9		12	I										
		pr2_pru1_gpo9		13	O										
		gpio5_3		14	IO										
		Driver off		15	I										
G13	mcasep1_axr2	mcasep1_axr2		0	IO	PD	PD	15	1.8/3.3	vddshv3	Yes	Dual Voltage LVCMOS	PU/PD	0	
		mcasep6_axr2		1	IO									0	
		uart6_ctsn		3	I									1	
		vout2_d2	No	6	O										
		vin4a_d2		8	I									0	
		gpio5_4		14	IO										
		Driver off		15	I										
J11	mcasep1_axr3	mcasep1_axr3		0	IO	PD	PD	15	1.8/3.3	vddshv3	Yes	Dual Voltage LVCMOS	PU/PD	0	
		mcasep6_axr3		1	IO									0	
		uart6_rtsn		3	O										
		vout2_d3	No	6	O										
		vin4a_d3		8	I									0	
		gpio5_5		14	IO										
		Driver off		15	I										
E12	mcasep1_axr4	mcasep1_axr4		0	IO	PD	PD	15	1.8/3.3	vddshv3	Yes	Dual Voltage LVCMOS	PU/PD	0	
		mcasep4_axr2		1	IO									0	
		vout2_d4	No	6	O										
		vin4a_d4		8	I									0	
		gpio5_6		14	IO										
		Driver off		15	I										
F13	mcasep1_axr5	mcasep1_axr5		0	IO	PD	PD	15	1.8/3.3	vddshv3	Yes	Dual Voltage LVCMOS	PU/PD	0	
		mcasep4_axr3		1	IO									0	
		vout2_d5	No	6	O										
		vin4a_d5		8	I									0	
		gpio5_7		14	IO										
		Driver off		15	I										

Table 4-1. Pin Attributes<sup>(1)</sup> (continued)

BALL NUMBER [1]	BALL NAME [2]	SIGNAL NAME [3]	PN [4]	MUXMODE [5]	TYPE [6]	BALL RESET STATE [7]	BALL RESET REL. STATE [8]	BALL RESET REL. MUXMODE [9]	I/O VOLTAGE VALUE [10]	POWER [11]	HYS [12]	BUFFER TYPE [13]	PULL UP/DOWN TYPE [14]	DSIS [15]
C12	mcasep1_axr6	mcasep1_axr6		0	IO	PD	PD	15	1.8/3.3	vddshv3	Yes	Dual Voltage LVCMOS	PU/PD	0
		mcasep5_axr2		1	IO									0
		vout2_d6	No	6	O									0
		vin4a_d6		8	I									
		gpio5_8		14	IO									
		Driver off		15	I									
D12	mcasep1_axr7	mcasep1_axr7		0	IO	PD	PD	15	1.8/3.3	vddshv3	Yes	Dual Voltage LVCMOS	PU/PD	0
		mcasep5_axr3		1	IO									0
		vout2_d7	No	6	O									0
		vin4a_d7		8	I									
		timer4		10	IO									
		gpio5_9		14	IO									
Driver off		15	I											
B12	mcasep1_axr8	mcasep1_axr8		0	IO	PD	PD	15	1.8/3.3	vddshv3	Yes	Dual Voltage LVCMOS	PU/PD	0
		mcasep6_axr0		1	IO									0
		spi3_sclk		3	IO									0
		timer5		10	IO									
		pr2_mii0_txen		11	O									
		pr2_pru1_gpi10		12	I									
		pr2_pru1_gpo10		13	O									
		gpio5_10		14	IO									
Driver off		15	I											
A11	mcasep1_axr9	mcasep1_axr9		0	IO	PD	PD	15	1.8/3.3	vddshv3	Yes	Dual Voltage LVCMOS	PU/PD	0
		mcasep6_axr1		1	IO									0
		spi3_d1		3	IO									0
		timer6		10	IO									
		pr2_mii0_txd3		11	O									
		pr2_pru1_gpi11		12	I									
		pr2_pru1_gpo11		13	O									
		gpio5_11		14	IO									
Driver off		15	I											

Table 4-1. Pin Attributes<sup>(1)</sup> (continued)

BALL NUMBER [1]	BALL NAME [2]	SIGNAL NAME [3]	PN [4]	MUXMODE [5]	TYPE [6]	BALL RESET STATE [7]	BALL RESET REL. STATE [8]	BALL RESET REL. MUXMODE [9]	I/O VOLTAGE VALUE [10]	POWER [11]	HYS [12]	BUFFER TYPE [13]	PULL UP/DOWN TYPE [14]	DSIS [15]
B13	mcasep1_axr10	mcasep1_axr10		0	IO	PD	PD	15	1.8/3.3	vddshv3	Yes	Dual Voltage LVCMOS	PU/PD	0
		mcasep6_aclkx		1	IO									0
		mcasep6_aclkr		2	IO									
		spi3_d0		3	IO									
		timer7		10	IO									
		pr2_mii0_txd2		11	O									
		pr2_pru1_gpi12		12	I									
		pr2_pru1_gpo12		13	O									
		gpio5_12		14	IO									
Driver off		15	I											
A12	mcasep1_axr11	mcasep1_axr11		0	IO	PD	PD	15	1.8/3.3	vddshv3	Yes	Dual Voltage LVCMOS	PU/PD	0
		mcasep6_fsx		1	IO									
		mcasep6_fsr		2	IO									
		spi3_cs0		3	IO									1
		timer8		10	IO									
		pr2_mii0_txd1		11	O									
		pr2_pru1_gpi13		12	I									
		pr2_pru1_gpo13		13	O									
		gpio4_17		14	IO									
Driver off		15	I											
E14	mcasep1_axr12	mcasep1_axr12		0	IO	PD	PD	15	1.8/3.3	vddshv3	Yes	Dual Voltage LVCMOS	PU/PD	0
		mcasep7_axr0		1	IO									0
		spi3_cs1		3	IO									1
		timer9		10	IO									
		pr2_mii0_txd0		11	O									
		pr2_pru1_gpi14		12	I									
		pr2_pru1_gpo14		13	O									
		gpio4_18		14	IO									
		Driver off		15	I									
A13	mcasep1_axr13	mcasep1_axr13		0	IO	PD	PD	15	1.8/3.3	vddshv3	Yes	Dual Voltage LVCMOS	PU/PD	0
		mcasep7_axr1		1	IO									0
		timer10		10	IO									
		pr2_mii_mr0_clk		11	I									0
		pr2_pru1_gpi15		12	I									
		pr2_pru1_gpo15		13	O									
		gpio6_4		14	IO									
		Driver off		15	I									

Table 4-1. Pin Attributes<sup>(1)</sup> (continued)

BALL NUMBER [1]	BALL NAME [2]	SIGNAL NAME [3]	PN [4]	MUXMODE [5]	TYPE [6]	BALL RESET STATE [7]	BALL RESET REL. STATE [8]	BALL RESET REL. MUXMODE [9]	I/O VOLTAGE VALUE [10]	POWER [11]	HYS [12]	BUFFER TYPE [13]	PULL UP/DOWN TYPE [14]	DSIS [15]	
G14	mcasep1_axr14	mcasep1_axr14		0	IO	PD	PD	15	1.8/3.3	vddshv3	Yes	Dual Voltage LVCMOS	PU/PD	0	
		mcasep7_aclkx		1	IO									0	
		mcasep7_aclkr		2	IO										
		timer11		10	IO										
		pr2_mii0_rxdv		11	I										0
		pr2_pru1_gpi16		12	I										
		pr2_pru1_gpo16		13	O										
		gpio6_5		14	IO										
Driver off		15	I												
F14	mcasep1_axr15	mcasep1_axr15		0	IO	PD	PD	15	1.8/3.3	vddshv3	Yes	Dual Voltage LVCMOS	PU/PD	0	
		mcasep7_fsx		1	IO										
		mcasep7_fsr		2	IO										
		timer12		10	IO										
		pr2_mii0_rxd3		11	I										0
		pr2_pru0_gpi20		12	I										
		pr2_pru0_gpo20		13	O										
		gpio6_6		14	IO										
Driver off		15	I												
J14	mcasep1_fsr	mcasep1_fsr		0	IO	PD	PD	15	1.8/3.3	vddshv3	Yes	Dual Voltage LVCMOS	PU/PD	0	
		mcasep7_axr3		1	IO										
		vout2_d1	No	6	O										
		vin4a_d1		8	I										0
		i2c4_scl		10	IO										1
		gpio5_1		14	IO										
		Driver off		15	I										
D14	mcasep1_fsx	mcasep1_fsx		0	IO	PD	PD	15	1.8/3.3	vddshv3	Yes	Dual Voltage LVCMOS	PU/PD	0	
		i2c3_scl		10	IO										1
		pr2_mdio_data		11	IO										1
		gpio7_30		14	IO										
		Driver off		15	I										
E15	mcasep2_aclkr	mcasep2_aclkr		0	IO	PD	PD	15	1.8/3.3	vddshv3	Yes	Dual Voltage LVCMOS	PU/PD	0	
		mcasep8_axr2		1	IO										
		vout2_d8	No	6	O										
		vin4a_d8		8	I										0
		Driver off		15	I										

Table 4-1. Pin Attributes<sup>(1)</sup> (continued)

BALL NUMBER [1]	BALL NAME [2]	SIGNAL NAME [3]	PN [4]	MUXMODE [5]	TYPE [6]	BALL RESET STATE [7]	BALL RESET REL. STATE [8]	BALL RESET REL. MUXMODE [9]	I/O VOLTAGE VALUE [10]	POWER [11]	HYS [12]	BUFFER TYPE [13]	PULL UP/DOWN TYPE [14]	DSIS [15]
A19	mcasep2_aclkx	mcasep2_aclkx		0	IO	PD	PD	15	1.8/3.3	vddshv3	Yes	Dual Voltage LVCMOS	PU/PD	0
		pr2_mii0_rxd2		11	I									0
		pr2_pru0_gpi18		12	I									
		pr2_pru0_gpo18		13	O									
		Driver off		15	I									
B15	mcasep2_axr0	mcasep2_axr0		0	IO	PD	PD	15	1.8/3.3	vddshv3	Yes	Dual Voltage LVCMOS	PU/PD	0
		vout2_d10	No	6	O									
		vin4a_d10		8	I									0
		Driver off		15	I									
A15	mcasep2_axr1	mcasep2_axr1		0	IO	PD	PD	15	1.8/3.3	vddshv3	Yes	Dual Voltage LVCMOS	PU/PD	0
		vout2_d11	No	6	O									
		vin4a_d11		8	I									0
		Driver off		15	I									
C15	mcasep2_axr2	mcasep2_axr2		0	IO	PD	PD	15	1.8/3.3	vddshv3	Yes	Dual Voltage LVCMOS	PU/PD	0
		mcasep3_axr2		1	IO									0
		pr2_mii0_rxd0		11	I									0
		pr2_pru0_gpi16		12	I									
		pr2_pru0_gpo16		13	O									
		gpio6_8		14	IO									
		Driver off		15	I									
A16	mcasep2_axr3	mcasep2_axr3		0	IO	PD	PD	15	1.8/3.3	vddshv3	Yes	Dual Voltage LVCMOS	PU/PD	0
		mcasep3_axr3		1	IO									0
		pr2_mii0_rlink		11	I									0
		pr2_pru0_gpi17		12	I									
		pr2_pru0_gpo17		13	O									
		gpio6_9		14	IO									
		Driver off		15	I									
D15	mcasep2_axr4	mcasep2_axr4		0	IO	PD	PD	15	1.8/3.3	vddshv3	Yes	Dual Voltage LVCMOS	PU/PD	0
		mcasep8_axr0		1	IO									0
		vout2_d12	No	6	O									
		vin4a_d12		8	I									0
		gpio1_4		14	IO									
		Driver off		15	I									

Table 4-1. Pin Attributes<sup>(1)</sup> (continued)

BALL NUMBER [1]	BALL NAME [2]	SIGNAL NAME [3]	PN [4]	MUXMODE [5]	TYPE [6]	BALL RESET STATE [7]	BALL RESET REL. STATE [8]	BALL RESET REL. MUXMODE [9]	I/O VOLTAGE VALUE [10]	POWER [11]	HYS [12]	BUFFER TYPE [13]	PULL UP/DOWN TYPE [14]	DSIS [15]
B16	mcasep2_axr5	mcasep2_axr5		0	IO	PD	PD	15	1.8/3.3	vddshv3	Yes	Dual Voltage LVCMOS	PU/PD	0
		mcasep8_axr1		1	IO									0
		vout2_d13	No	6	O									0
		vin4a_d13		8	I									0
		gpio6_7		14	IO									
		Driver off		15	I									
B17	mcasep2_axr6	mcasep2_axr6		0	IO	PD	PD	15	1.8/3.3	vddshv3	Yes	Dual Voltage LVCMOS	PU/PD	0
		mcasep8_aclkx		1	IO									0
		mcasep8_aclkr		2	IO									
		vout2_d14	No	6	O									0
		vin4a_d14		8	I									0
		gpio2_29		14	IO									
		Driver off		15	I									
A17	mcasep2_axr7	mcasep2_axr7		0	IO	PD	PD	15	1.8/3.3	vddshv3	Yes	Dual Voltage LVCMOS	PU/PD	0
		mcasep8_fsx		1	IO									0
		mcasep8_fsr		2	IO									
		vout2_d15	No	6	O									0
		vin4a_d15		8	I									0
		gpio1_5		14	IO									
		Driver off		15	I									
A20	mcasep2_fsr	mcasep2_fsr		0	IO	PD	PD	15	1.8/3.3	vddshv3	Yes	Dual Voltage LVCMOS	PU/PD	0
		mcasep8_axr3		1	IO									0
		vout2_d9	No	6	O									0
		vin4a_d9		8	I									0
		Driver off		15	I									
A18	mcasep2_fsx	mcasep2_fsx		0	IO	PD	PD	15	1.8/3.3	vddshv3	Yes	Dual Voltage LVCMOS	PU/PD	0
		pr2_mii0_rxd1		11	I									0
		pr2_pru0_gpi19		12	I									
		pr2_pru0_gpo19		13	O									
		Driver off		15	I									



Table 4-1. Pin Attributes<sup>(1)</sup> (continued)

BALL NUMBER [1]	BALL NAME [2]	SIGNAL NAME [3]	PN [4]	MUXMODE [5]	TYPE [6]	BALL RESET STATE [7]	BALL RESET REL. STATE [8]	BALL RESET REL. MUXMODE [9]	I/O VOLTAGE VALUE [10]	POWER [11]	HYS [12]	BUFFER TYPE [13]	PULL UP/DOWN TYPE [14]	DSIS [15]		
B18	mcasep3_aclkx	mcasep3_aclkx		0	IO	PD	PD	15	1.8/3.3	vddshv3	Yes	Dual Voltage LVCMOS	PU/PD	0		
		mcasep3_aclkr		1	IO											
		mcasep2_axr12		2	IO											0
		uart7_rxd		3	I											1
		pr2_mii0_crs		11	I											0
		pr2_pru0_gpi12		12	I											
		pr2_pru0_gpo12		13	O											
		gpio5_13		14	IO											
Driver off		15	I													
B19	mcasep3_axr0	mcasep3_axr0		0	IO	PD	PD	15	1.8/3.3	vddshv3	Yes	Dual Voltage LVCMOS	PU/PD	0		
		mcasep2_axr14		2	IO											0
		uart7_ctsn		3	I											1
		uart5_rxd		4	I											1
		pr2_mii1_rxer		11	I											0
		pr2_pru0_gpi14		12	I											
		pr2_pru0_gpo14		13	O											
		Driver off		15	I											
C17	mcasep3_axr1	mcasep3_axr1		0	IO	PD	PD	15	1.8/3.3	vddshv3	Yes	Dual Voltage LVCMOS	PU/PD	0		
		mcasep2_axr15		2	IO											0
		uart7_rtsn		3	O											
		uart5_txd		4	O											
		pr2_mii1_rxlink		11	I											0
		pr2_pru0_gpi15		12	I											
		pr2_pru0_gpo15		13	O											
		Driver off		15	I											
F15	mcasep3_fsx	mcasep3_fsx		0	IO	PD	PD	15	1.8/3.3	vddshv3	Yes	Dual Voltage LVCMOS	PU/PD	0		
		mcasep3_fsr		1	IO											
		mcasep2_axr13		2	IO											0
		uart7_txd		3	O											
		pr2_mii0_col		11	I											0
		pr2_pru0_gpi13		12	I											
		pr2_pru0_gpo13		13	O											
		gpio5_14		14	IO											
Driver off		15	I													

Table 4-1. Pin Attributes<sup>(1)</sup> (continued)

BALL NUMBER [1]	BALL NAME [2]	SIGNAL NAME [3]	PN [4]	MUXMODE [5]	TYPE [6]	BALL RESET STATE [7]	BALL RESET REL. STATE [8]	BALL RESET REL. MUXMODE [9]	I/O VOLTAGE VALUE [10]	POWER [11]	HYS [12]	BUFFER TYPE [13]	PULL UP/DOWN TYPE [14]	DSIS [15]		
C18	mcasep4_acllx	mcasep4_acllx		0	IO	PD	PD	15	1.8/3.3	vddshv3	Yes	Dual Voltage LVCMOS	PU/PD	0		
		mcasep4_aclkr		1	IO											
		spi3_sclk		2	IO											0
		uart8_rxd		3	I											1
		i2c4_sda		4	IO											1
		vout2_d16	No	6	O											
		vin4a_d16		8	I											0
		Driver off		15	I											
G16	mcasep4_axr0	mcasep4_axr0		0	IO	PD	PD	15	1.8/3.3	vddshv3	Yes	Dual Voltage LVCMOS	PU/PD	0		
		spi3_d0		2	IO											0
		uart8_ctsn		3	I											1
		uart4_rxd		4	I											1
		vout2_d18	No	6	O											
		vin4a_d18		8	I											0
		Driver off		15	I											
		D17	mcasep4_axr1	mcasep4_axr1		0	IO	PD	PD	15	1.8/3.3			vddshv3	Yes	Dual Voltage LVCMOS
spi3_cs0				2	IO									1		
uart8_rtsn				3	O											
uart4_txd				4	O											
vout2_d19	No			6	O											
vin4a_d19				8	I									0		
pr2_pru1_gpi0				12	I											
pr2_pru1_gpo0				13	O											
Driver off		15	I													
A21	mcasep4_fsx	mcasep4_fsx		0	IO	PD	PD	15	1.8/3.3	vddshv3	Yes	Dual Voltage LVCMOS	PU/PD	0		
		mcasep4_fsr		1	IO											
		spi3_d1		2	IO											0
		uart8_txd		3	O											
		i2c4_scl		4	IO											1
		vout2_d17	No	6	O											
		vin4a_d17		8	I											0
		Driver off		15	I											

Table 4-1. Pin Attributes<sup>(1)</sup> (continued)

BALL NUMBER [1]	BALL NAME [2]	SIGNAL NAME [3]	PN [4]	MUXMODE [5]	TYPE [6]	BALL RESET STATE [7]	BALL RESET REL. STATE [8]	BALL RESET REL. MUXMODE [9]	I/O VOLTAGE VALUE [10]	POWER [11]	HYS [12]	BUFFER TYPE [13]	PULL UP/DOWN TYPE [14]	DSIS [15]		
AA3	mcasep5_aclkx	mcasep5_aclkx		0	IO	PD	PD	15	1.8/3.3	vddshv7	Yes	Dual Voltage LVCMOS	PU/PD	0		
		mcasep5_aclkr		1	IO											
		spi4_sclk		2	IO											0
		uart9_rxd		3	I											1
		i2c5_sda		4	IO											1
		vout2_d20	No	6	O											
		vin4a_d20		8	I											0
		pr2_pru1_gpi1		12	I											
		pr2_pru1_gpo1		13	O											
		Driver off		15	I											
AB3	mcasep5_axr0	mcasep5_axr0		0	IO	PD	PD	15	1.8/3.3	vddshv7	Yes	Dual Voltage LVCMOS	PU/PD	0		
		spi4_d0		2	IO											0
		uart9_ctsn		3	I											1
		uart3_rxd		4	I											1
		vout2_d22	No	6	O											
		vin4a_d22		8	I											0
		pr2_mdio_mdclk		11	O											
		pr2_pru1_gpi3		12	I											
		pr2_pru1_gpo3		13	O											
		Driver off		15	I											
AA4	mcasep5_axr1	mcasep5_axr1		0	IO	PD	PD	15	1.8/3.3	vddshv7	Yes	Dual Voltage LVCMOS	PU/PD	0		
		spi4_cs0		2	IO											1
		uart9_rtsn		3	O											
		uart3_txd		4	O											
		vout2_d23	No	6	O											
		vin4a_d23		8	I											0
		pr2_mdio_data		11	IO											1
		pr2_pru1_gpi4		12	I											
		pr2_pru1_gpo4		13	O											
		Driver off		15	I											

Table 4-1. Pin Attributes<sup>(1)</sup> (continued)

BALL NUMBER [1]	BALL NAME [2]	SIGNAL NAME [3]	PN [4]	MUXMODE [5]	TYPE [6]	BALL RESET STATE [7]	BALL RESET REL. STATE [8]	BALL RESET REL. MUXMODE [9]	I/O VOLTAGE VALUE [10]	POWER [11]	HYS [12]	BUFFER TYPE [13]	PULL UP/DOWN TYPE [14]	DSIS [15]			
AB9	mcasep5_fsx	mcasep5_fsx		0	IO	PD	PD	15	1.8/3.3	vddshv7	Yes	Dual Voltage LVCMOS	PU/PD	0			
		mcasep5_fsr		1	IO												
		spi4_d1		2	IO												0
		uart9_txd		3	O												
		i2c5_scl		4	IO												1
		vout2_d21	No	6	O												
		vin4a_d21		8	I												0
		pr2_pru1_gpi2		12	I												
		pr2_pru1_gpo2		13	O												
	Driver off		15	I													
U4	mdio_d	mdio_d		0	IO	PU	PU	15	1.8/3.3	vddshv9	Yes	Dual Voltage LVCMOS	PU/PD	1			
		uart3_ctsn		1	I												1
		mii0_txer		3	O												0
		vin2a_d0		4	I												0
		vin4b_d0		5	I												0
		pr1_mii0_rlink		11	I												0
		pr2_pru1_gpi1		12	I												
		pr2_pru1_gpo1		13	O												
			gpio5_16		14	IO											
	Driver off		15	I													
V1	mdio_mclk	mdio_mclk		0	O	PU	PU	15	1.8/3.3	vddshv9	Yes	Dual Voltage LVCMOS	PU/PD	1			
		uart3_rtsn		1	O												
		mii0_col		3	I												0
		vin2a_clk0		4	I												
		vin4b_clk1		5	I												0
		pr1_mii0_col		11	I												0
		pr2_pru1_gpi0		12	I												
		pr2_pru1_gpo0		13	O												
			gpio5_15		14	IO											
	Driver off		15	I													
AB2	mlbp_clk_n	mlbp_clk_n		0	I				1.8	vdds_mlbp	No	BMLB18					
AB1	mlbp_clk_p	mlbp_clk_p		0	I				1.8	vdds_mlbp	No	BMLB18					
AA2	mlbp_dat_n	mlbp_dat_n		0	IO	OFF	OFF		1.8	vdds_mlbp	No	BMLB18					
AA1	mlbp_dat_p	mlbp_dat_p		0	IO	OFF	OFF		1.8	vdds_mlbp	No	BMLB18					
AC2	mlbp_sig_n	mlbp_sig_n		0	IO	OFF	OFF		1.8	vdds_mlbp	No	BMLB18					
AC1	mlbp_sig_p	mlbp_sig_p		0	IO	OFF	OFF		1.8	vdds_mlbp	No	BMLB18					

Table 4-1. Pin Attributes<sup>(1)</sup> (continued)

BALL NUMBER [1]	BALL NAME [2]	SIGNAL NAME [3]	PN [4]	MUXMODE [5]	TYPE [6]	BALL RESET STATE [7]	BALL RESET REL. STATE [8]	BALL RESET REL. MUXMODE [9]	I/O VOLTAGE VALUE [10]	POWER [11]	HYS [12]	BUFFER TYPE [13]	PULL UP/DOWN TYPE [14]	DSIS [15]
W6	mmc1_clk	mmc1_clk		0	IO	PU	PU	15	1.8/3.3	vddshv8	Yes	SDIO1833	PU/PD	1
		gpio6_21		14	IO									
		Driver off		15	I									
Y6	mmc1_cmd	mmc1_cmd		0	IO	PU	PU	15	1.8/3.3	vddshv8	Yes	SDIO1833	PU/PD	1
		gpio6_22		14	IO									
		Driver off		15	I									
AA6	mmc1_dat0	mmc1_dat0		0	IO	PU	PU	15	1.8/3.3	vddshv8	Yes	SDIO1833	PU/PD	1
		gpio6_23		14	IO									
		Driver off		15	I									
Y4	mmc1_dat1	mmc1_dat1		0	IO	PU	PU	15	1.8/3.3	vddshv8	Yes	SDIO1833	PU/PD	1
		gpio6_24		14	IO									
		Driver off		15	I									
AA5	mmc1_dat2	mmc1_dat2		0	IO	PU	PU	15	1.8/3.3	vddshv8	Yes	SDIO1833	PU/PD	1
		gpio6_25		14	IO									
		Driver off		15	I									
Y3	mmc1_dat3	mmc1_dat3		0	IO	PU	PU	15	1.8/3.3	vddshv8	Yes	SDIO1833	PU/PD	1
		gpio6_26		14	IO									
		Driver off		15	I									
W7	mmc1_sdcd	mmc1_sdcd		0	I	PU	PU	15	1.8/3.3	vddshv8	Yes	Dual Voltage LVCMOS	PU/PD	1
		uart6_rxd		3	I									1
		i2c4_sda		4	IO									1
		gpio6_27		14	IO									
		Driver off		15	I									
Y9	mmc1_sdwp	mmc1_sdwp		0	I	PD	PD	15	1.8/3.3	vddshv8	Yes	Dual Voltage LVCMOS	PU/PD	0
		uart6_txd		3	O									
		i2c4_scl		4	IO									1
		gpio6_28		14	IO									
		Driver off		15	I									
AD4	mmc3_clk	mmc3_clk		0	IO	PU	PU	15	1.8/3.3	vddshv7	Yes	Dual Voltage LVCMOS	PU/PD	1
		vin2b_d7		4	I									0
		ehrpwm2_tripzone_input		10	IO									0
		pr2_mii1_txd3		11	O									
		pr2_pru0_gpi2		12	I									
		pr2_pru0_gpo2		13	O									
		gpio6_29		14	IO									
		Driver off		15	I									

Table 4-1. Pin Attributes<sup>(1)</sup> (continued)

BALL NUMBER [1]	BALL NAME [2]	SIGNAL NAME [3]	PN [4]	MUXMODE [5]	TYPE [6]	BALL RESET STATE [7]	BALL RESET REL. STATE [8]	BALL RESET REL. MUXMODE [9]	I/O VOLTAGE VALUE [10]	POWER [11]	HYS [12]	BUFFER TYPE [13]	PULL UP/DOWN TYPE [14]	DSIS [15]
AC4	mmc3_cmd	mmc3_cmd		0	IO	PU	PU	15	1.8/3.3	vddshv7	Yes	Dual Voltage LVCMOS	PU/PD	1
		spi3_sclk		1	IO									0
		vin2b_d6		4	I									0
		eCAP2_in_PWM2_out		10	IO									0
		pr2_mii1_txd2		11	O									
		pr2_pru0_gpi3		12	I									
		pr2_pru0_gpo3		13	O									
		gpio6_30		14	IO									
Driver off		15	I											
AC7	mmc3_dat0	mmc3_dat0		0	IO	PU	PU	15	1.8/3.3	vddshv7	Yes	Dual Voltage LVCMOS	PU/PD	1
		spi3_d1		1	IO									0
		uart5_rxd		2	I									1
		vin2b_d5		4	I									0
		eQEP3A_in		10	I									0
		pr2_mii1_txd1		11	O									
		pr2_pru0_gpi4		12	I									
		pr2_pru0_gpo4		13	O									
		gpio6_31		14	IO									
		Driver off		15	I									
AC6	mmc3_dat1	mmc3_dat1		0	IO	PU	PU	15	1.8/3.3	vddshv7	Yes	Dual Voltage LVCMOS	PU/PD	1
		spi3_d0		1	IO									0
		uart5_txd		2	O									
		vin2b_d4		4	I									0
		eQEP3B_in		10	I									0
		pr2_mii1_txd0		11	O									
		pr2_pru0_gpi5		12	I									
		pr2_pru0_gpo5		13	O									
		gpio7_0		14	IO									
		Driver off		15	I									

Table 4-1. Pin Attributes<sup>(1)</sup> (continued)

BALL NUMBER [1]	BALL NAME [2]	SIGNAL NAME [3]	PN [4]	MUXMODE [5]	TYPE [6]	BALL RESET STATE [7]	BALL RESET REL. STATE [8]	BALL RESET REL. MUXMODE [9]	I/O VOLTAGE VALUE [10]	POWER [11]	HYS [12]	BUFFER TYPE [13]	PULL UP/DOWN TYPE [14]	DSIS [15]
AC9	mmc3_dat2	mmc3_dat2		0	IO	PU	PU	15	1.8/3.3	vddshv7	Yes	Dual Voltage LVCMOS	PU/PD	1
		spi3_cs0		1	IO									1
		uart5_ctsn		2	I									1
		vin2b_d3		4	I									0
		eQEP3_index		10	IO									0
		pr2_mii_mr1_clk		11	I									0
		pr2_pru0_gpi6		12	I									
		pr2_pru0_gpo6		13	O									
		gpio7_1		14	IO									
Driver off		15	I											
AC3	mmc3_dat3	mmc3_dat3		0	IO	PU	PU	15	1.8/3.3	vddshv7	Yes	Dual Voltage LVCMOS	PU/PD	1
		spi3_cs1		1	IO									1
		uart5_rtsn		2	O									
		vin2b_d2		4	I									0
		eQEP3_strobe		10	IO									0
		pr2_mii1_rxdv		11	I									0
		pr2_pru0_gpi7		12	I									
		pr2_pru0_gpo7		13	O									
		gpio7_2		14	IO									
Driver off		15	I											
AC8	mmc3_dat4	mmc3_dat4		0	IO	PU	PU	15	1.8/3.3	vddshv7	Yes	Dual Voltage LVCMOS	PU/PD	1
		spi4_sclk		1	IO									0
		uart10_rxd		2	I									1
		vin2b_d1		4	I									0
		ehrpwm3A		10	O									
		pr2_mii1_rxd3		11	I									0
		pr2_pru0_gpi8		12	I									
		pr2_pru0_gpo8		13	O									
		gpio1_22		14	IO									
Driver off		15	I											

Table 4-1. Pin Attributes<sup>(1)</sup> (continued)

BALL NUMBER [1]	BALL NAME [2]	SIGNAL NAME [3]	PN [4]	MUXMODE [5]	TYPE [6]	BALL RESET STATE [7]	BALL RESET REL. STATE [8]	BALL RESET REL. MUXMODE [9]	I/O VOLTAGE VALUE [10]	POWER [11]	HYS [12]	BUFFER TYPE [13]	PULL UP/DOWN TYPE [14]	DSIS [15]		
AD6	mmc3_dat5	mmc3_dat5		0	IO	PU	PU	15	1.8/3.3	vddshv7	Yes	Dual Voltage LVCMOS	PU/PD	1		
		spi4_d1		1	IO									0		
		uart10_txd		2	O										0	
		vin2b_d0		4	I											
		ehrpwm3B		10	O											0
		pr2_mii1_rxd2		11	I											0
		pr2_pru0_gpi9		12	I											
		pr2_pru0_gpo9		13	O											
		gpio1_23		14	IO											
Driver off		15	I													
AB8	mmc3_dat6	mmc3_dat6		0	IO	PU	PU	15	1.8/3.3	vddshv7	Yes	Dual Voltage LVCMOS	PU/PD	1		
		spi4_d0		1	IO										0	
		uart10_ctsn		2	I										1	
		vin2b_de1		4	I											
		ehrpwm3_tripzone_input		10	IO											0
		pr2_mii1_rxd1		11	I											0
		pr2_pru0_gpi10		12	I											
		pr2_pru0_gpo10		13	O											
		gpio1_24		14	IO											
Driver off		15	I													
AB5	mmc3_dat7	mmc3_dat7		0	IO	PU	PU	15	1.8/3.3	vddshv7	Yes	Dual Voltage LVCMOS	PU/PD	1		
		spi4_cs0		1	IO										1	
		uart10_rtsn		2	O											
		vin2b_clk1		4	I											
		eCAP3_in_PWM3_out		10	IO											0
		pr2_mii1_rxd0		11	I											0
		pr2_pru0_gpi11		12	I											
		pr2_pru0_gpo11		13	O											
		gpio1_25		14	IO											
Driver off		15	I													
D21	nmin_dsp	nmin_dsp		0	I	PD	PD		1.8/3.3	vddshv3	Yes	Dual Voltage LVCMOS	PU/PD			
Y11	on_off	on_off		0	O	PU	drive 1 (OFF)		1.8/3.3	vddshv5	Yes	BC1833IHH V	PU/PD			
AG13	pcie_rxn0	pcie_rxn0		0	I	OFF	OFF		1.8	vdda_pcie0		SERDES				
AG11	pcie_rxn1	pcie_rxn1		0	I	OFF	OFF		1.8	vdda_pcie1		SERDES				
AH13	pcie_rxp0	pcie_rxp0		0	I	OFF	OFF		1.8	vdda_pcie0		SERDES				



Table 4-1. Pin Attributes<sup>(1)</sup> (continued)

BALL NUMBER [1]	BALL NAME [2]	SIGNAL NAME [3]	PN [4]	MUXMODE [5]	TYPE [6]	BALL RESET STATE [7]	BALL RESET REL. STATE [8]	BALL RESET REL. MUXMODE [9]	I/O VOLTAGE VALUE [10]	POWER [11]	HYS [12]	BUFFER TYPE [13]	PULL UP/DOWN TYPE [14]	DSIS [15]
AH11	pcie_rxp1	pcie_rxp1		0	I	OFF	OFF		1.8	vdda_pcie1		SERDES		
AG14	pcie_txn0	pcie_txn0		0	O				1.8	vdda_pcie0		SERDES		
AG12	pcie_txn1	pcie_txn1		0	O				1.8	vdda_pcie1		SERDES		
AH14	pcie_txp0	pcie_txp0		0	O				1.8	vdda_pcie0		SERDES		
AH12	pcie_txp1	pcie_txp1		0	O				1.8	vdda_pcie1		SERDES		
F22	porz	porz		0	I				1.8/3.3	vddshv3	Yes	IHHV1833	PU/PD	
E23	resetrn	resetrn		0	I	PU	PU		1.8/3.3	vddshv3	Yes	Dual Voltage LVCMOS	PU/PD	
U5	rgmii0_rxc	rgmii0_rxc		0	I	PD	PD	15	1.8/3.3	vddshv9	Yes	Dual Voltage LVCMOS	PU/PD	0
		rmii1_txen		2	O									0
		mii0_txcclk		3	I									0
		vin2a_d5		4	I									0
		vin4b_d5		5	I									0
		pr1_mii_mt0_clk		11	I									0
		pr2_pru1_gpi11		12	I									
		pr2_pru1_gpo11		13	O									
		gpio5_26		14	IO									
		Driver off		15	I									
V5	rgmii0_rxctl	rgmii0_rxctl		0	I	PD	PD	15	1.8/3.3	vddshv9	Yes	Dual Voltage LVCMOS	PU/PD	0
		rmii1_txd1		2	O									
		mii0_txd3		3	O									
		vin2a_d6		4	I									0
		vin4b_d6		5	I									0
		pr1_mii0_txd3		11	O									
		pr2_pru1_gpi12		12	I									
		pr2_pru1_gpo12		13	O									
		gpio5_27		14	IO									
		Driver off		15	I									

Table 4-1. Pin Attributes<sup>(1)</sup> (continued)

BALL NUMBER [1]	BALL NAME [2]	SIGNAL NAME [3]	PN [4]	MUXMODE [5]	TYPE [6]	BALL RESET STATE [7]	BALL RESET REL. STATE [8]	BALL RESET REL. MUXMODE [9]	I/O VOLTAGE VALUE [10]	POWER [11]	HYS [12]	BUFFER TYPE [13]	PULL UP/DOWN TYPE [14]	DSIS [15]
W2	rgmii0_rxd0	rgmii0_rxd0		0	I	PD	PD	15	1.8/3.3	vddshv9	Yes	Dual Voltage LVCMOS	PU/PD	0
		rmii0_txd0		1	O									
		mii0_txd0		3	O									
		vin2a_fld0		4	I									
		vin4b_fld1		5	I									
		pr1_mii0_txd0		11	O									0
		pr2_pru1_gpi16		12	I									
		pr2_pru1_gpo16		13	O									
		gpio5_31		14	IO									
Driver off		15	I											
Y2	rgmii0_rxd1	rgmii0_rxd1		0	I	PD	PD	15	1.8/3.3	vddshv9	Yes	Dual Voltage LVCMOS	PU/PD	0
		rmii0_txd1		1	O									
		mii0_txd1		3	O									
		vin2a_d9		4	I									0
		pr1_mii0_txd1		11	O									
		pr2_pru1_gpi15		12	I									
		pr2_pru1_gpo15		13	O									
		gpio5_30		14	IO									
		Driver off		15	I									
V3	rgmii0_rxd2	rgmii0_rxd2		0	I	PD	PD	15	1.8/3.3	vddshv9	Yes	Dual Voltage LVCMOS	PU/PD	0
		rmii0_txen		1	O									
		mii0_txen		3	O									
		vin2a_d8		4	I									0
		pr1_mii0_txen		11	O									
		pr2_pru1_gpi14		12	I									
		pr2_pru1_gpo14		13	O									
		gpio5_29		14	IO									
		Driver off		15	I									

Table 4-1. Pin Attributes<sup>(1)</sup> (continued)

BALL NUMBER [1]	BALL NAME [2]	SIGNAL NAME [3]	PN [4]	MUXMODE [5]	TYPE [6]	BALL RESET STATE [7]	BALL RESET REL. STATE [8]	BALL RESET REL. MUXMODE [9]	I/O VOLTAGE VALUE [10]	POWER [11]	HYS [12]	BUFFER TYPE [13]	PULL UP/DOWN TYPE [14]	DSIS [15]			
V4	rgmii0_rxd3	rgmii0_rxd3		0	I	PD	PD	15	1.8/3.3	vddshv9	Yes	Dual Voltage LVCMOS	PU/PD	0			
		rmii1_txd0		2	O												
		mii0_txd2		3	O												
		vin2a_d7		4	I											0	
		vin4b_d7		5	I												0
		pr1_mii0_txd2		11	O												
		pr2_pru1_gpi13		12	I												
		pr2_pru1_gpo13		13	O												
		gpio5_28		14	IO												
Driver off		15	I														
W9	rgmii0_txc	rgmii0_txc		0	O	PD	PD	15	1.8/3.3	vddshv9	Yes	Dual Voltage LVCMOS	PU/PD				
		uart3_ctsn		1	I											1	
		rmii1_rxd1		2	I											0	
		mii0_rxd3		3	I											0	
		vin2a_d3		4	I												0
		vin4b_d3		5	I												0
		spi3_d0		7	IO												0
		spi4_cs2		8	IO												1
		pr1_mii0_rxd3		11	I												0
		pr2_pru1_gpi5		12	I												
		pr2_pru1_gpo5		13	O												
		gpio5_20		14	IO												
		Driver off		15	I												
		V9	rgmii0_txc1	rgmii0_txc1		0	O	PD	PD	15	1.8/3.3			vddshv9	Yes	Dual Voltage LVCMOS	PU/PD
uart3_rtsn				1	O												
rmii1_rxd0				2	I									0			
mii0_rxd2				3	I									0			
vin2a_d4				4	I										0		
vin4b_d4				5	I										0		
spi3_cs0				7	IO										1		
spi4_cs3				8	IO										1		
pr1_mii0_rxd2				11	I										0		
pr2_pru1_gpi6				12	I												
pr2_pru1_gpo6				13	O												
gpio5_21				14	IO												
Driver off				15	I												

Table 4-1. Pin Attributes<sup>(1)</sup> (continued)

BALL NUMBER [1]	BALL NAME [2]	SIGNAL NAME [3]	PN [4]	MUXMODE [5]	TYPE [6]	BALL RESET STATE [7]	BALL RESET REL. STATE [8]	BALL RESET REL. MUXMODE [9]	I/O VOLTAGE VALUE [10]	POWER [11]	HYS [12]	BUFFER TYPE [13]	PULL UP/DOWN TYPE [14]	DSIS [15]	
U6	rgmii0_txd0	rgmii0_txd0		0	O	PD	PD	15	1.8/3.3	vddshv9	Yes	Dual Voltage LVCMOS	PU/PD		
		rmii0_rxd0		1	I										0
		mii0_rxd0		3	I										0
		vin2a_d10		4	I										0
		spi4_cs0		7	IO										1
		uart4_rtsn		8	O										
		pr1_mii0_rxd0		11	I										0
		pr2_pru1_gpi10		12	I										
		pr2_pru1_gpo10		13	O										
		gpio5_25		14	IO										
Driver off		15	I												
V6	rgmii0_txd1	rgmii0_txd1		0	O	PD	PD	15	1.8/3.3	vddshv9	Yes	Dual Voltage LVCMOS	PU/PD		
		rmii0_rxd1		1	I										0
		mii0_rxd1		3	I										0
		vin2a_vsync0		4	I										0
		vin4b_vsync1		5	I										0
		spi4_d0		7	IO										0
		uart4_ctsn		8	IO										1
		pr1_mii0_rxd1		11	I										0
		pr2_pru1_gpi9		12	I										
		pr2_pru1_gpo9		13	O										
gpio5_24		14	IO												
Driver off		15	I												
U7	rgmii0_txd2	rgmii0_txd2		0	O	PD	PD	15	1.8/3.3	vddshv9	Yes	Dual Voltage LVCMOS	PU/PD		
		rmii0_rxer		1	I										0
		mii0_rxer		3	I										0
		vin2a_hsync0		4	I										0
		vin4b_hsync1		5	I										0
		spi4_d1		7	IO										0
		uart4_txd		8	O										
		pr1_mii0_rxer		11	I										0
		pr2_pru1_gpi8		12	I										
		pr2_pru1_gpo8		13	O										
gpio5_23		14	IO												
Driver off		15	I												

**Table 4-1. Pin Attributes<sup>(1)</sup> (continued)**

BALL NUMBER [1]	BALL NAME [2]	SIGNAL NAME [3]	PN [4]	MUXMODE [5]	TYPE [6]	BALL RESET STATE [7]	BALL RESET REL. STATE [8]	BALL RESET REL. MUXMODE [9]	I/O VOLTAGE VALUE [10]	POWER [11]	HYS [12]	BUFFER TYPE [13]	PULL UP/DOWN TYPE [14]	DSIS [15]
V7	rgmii0_txd3	rgmii0_txd3		0	O	PD	PD	15	1.8/3.3	vddshv9	Yes	Dual Voltage LVCMOS	PU/PD	
		rmii0_crs		1	I									0
		mii0_crs		3	I									0
		vin2a_de0		4	I									0
		vin4b_de1		5	I									0
		spi4_sclk		7	IO									0
		uart4_rxd		8	I									1
		pr1_mii0_crs		11	I									0
		pr2_pru1_gpi7		12	I									
		pr2_pru1_gpo7		13	O									
		gpio5_22		14	IO									
		Driver off		15	I									
		U3	RMII_MHZ_50_CLK	RMII_MHZ_50_CLK		0	IO	PD	PD	15	1.8/3.3	vddshv9	Yes	Dual Voltage LVCMOS
vin2a_d11				4	I									0
pr2_pru1_gpi2				12	I									
pr2_pru1_gpo2				13	O									
gpio5_17				14	IO									
Driver off				15	I									
F23	rstoutn	rstoutn		0	O	PD	drive 1 (OFF)		1.8/3.3	vddshv3	Yes	Dual Voltage LVCMOS	PU/PD	
E18	rtck	rtck		0	O	PU	drive clk (OFF)	0	1.8/3.3	vddshv3	Yes	Dual Voltage LVCMOS	PU/PD	
		gpio8_29		14	IO									
AF14	rtc_iso	rtc_iso		0	I				1.8/3.3	vddshv5	Yes	IHHV1833	PU/PD	
AE14	rtc_osc_xi_clkin32	rtc_osc_xi_clkin32		0	I				1.8	vdda_rtc	No	LVCMOS OSC		
AD14	rtc_osc_xo	rtc_osc_xo		0	O				1.8	vdda_rtc	No	LVCMOS OSC		
AB17	rtc_porz	rtc_porz		0	I				1.8/3.3	vddshv5	Yes	IHHV1833	PU/PD	
AH9	sata1_rxn0	sata1_rxn0		0	I	OFF	OFF		1.8	vdda_sata		SATAPHY		
AG9	sata1_rxp0	sata1_rxp0		0	I	OFF	OFF		1.8	vdda_sata		SATAPHY		
AG10	sata1_txn0	sata1_txn0		0	O				1.8	vdda_sata		SATAPHY		
AH10	sata1_txp0	sata1_txp0		0	O				1.8	vdda_sata		SATAPHY		
A24	spi1_cs0	spi1_cs0		0	IO	PU	PU	15	1.8/3.3	vddshv3	Yes	Dual Voltage LVCMOS	PU/PD	1
		gpio7_10		14	IO									
		Driver off		15	I									

Table 4-1. Pin Attributes<sup>(1)</sup> (continued)

BALL NUMBER [1]	BALL NAME [2]	SIGNAL NAME [3]	PN [4]	MUXMODE [5]	TYPE [6]	BALL RESET STATE [7]	BALL RESET REL. STATE [8]	BALL RESET REL. MUXMODE [9]	I/O VOLTAGE VALUE [10]	POWER [11]	HYS [12]	BUFFER TYPE [13]	PULL UP/DOWN TYPE [14]	DSIS [15]
A22	spi1_cs1	spi1_cs1		0	IO	PU	PU	15	1.8/3.3	vddshv3	Yes	Dual Voltage LVCMOS	PU/PD	1
		sata1_led		2	O									
		spi2_cs1		3	IO									1
		gpio7_11		14	IO									
		Driver off		15	I									
B21	spi1_cs2	spi1_cs2		0	IO	PU	PU	15	1.8/3.3	vddshv3	Yes	Dual Voltage LVCMOS	PU/PD	1
		uart4_rxd		1	I									1
		mmc3_sdcd		2	I									1
		spi2_cs2		3	IO									1
		dcan2_tx		4	IO									1
		mdio_mclk		5	O									1
		hdmi1_hpd	No	6	I									
		gpio7_12		14	IO									
		Driver off		15	I									
B20	spi1_cs3	spi1_cs3		0	IO	PU	PU	15	1.8/3.3	vddshv3	Yes	Dual Voltage LVCMOS	PU/PD	1
		uart4_txd		1	O									
		mmc3_sdwp		2	I									0
		spi2_cs3		3	IO									1
		dcan2_rx		4	IO									1
		mdio_d		5	IO									1
		hdmi1_cec	No	6	IO									
		gpio7_13		14	IO									
		Driver off		15	I									
B25	spi1_d0	spi1_d0		0	IO	PD	PD	15	1.8/3.3	vddshv3	Yes	Dual Voltage LVCMOS	PU/PD	0
		gpio7_9		14	IO									
		Driver off		15	I									
F16	spi1_d1	spi1_d1		0	IO	PD	PD	15	1.8/3.3	vddshv3	Yes	Dual Voltage LVCMOS	PU/PD	0
		gpio7_8		14	IO									
		Driver off		15	I									
A25	spi1_sclk	spi1_sclk		0	IO	PD	PD	15	1.8/3.3	vddshv3	Yes	Dual Voltage LVCMOS	PU/PD	0
		gpio7_7		14	IO									
		Driver off		15	I									
B24	spi2_cs0	spi2_cs0		0	IO	PU	PU	15	1.8/3.3	vddshv3	Yes	Dual Voltage LVCMOS	PU/PD	1
		uart3_rtsn		1	O									
		uart5_txd		2	O									
		gpio7_17		14	IO									
		Driver off		15	I									

**Table 4-1. Pin Attributes<sup>(1)</sup> (continued)**

BALL NUMBER [1]	BALL NAME [2]	SIGNAL NAME [3]	PN [4]	MUXMODE [5]	TYPE [6]	BALL RESET STATE [7]	BALL RESET REL. STATE [8]	BALL RESET REL. MUXMODE [9]	I/O VOLTAGE VALUE [10]	POWER [11]	HYS [12]	BUFFER TYPE [13]	PULL UP/DOWN TYPE [14]	DSIS [15]
G17	spi2_d0	spi2_d0		0	IO	PD	PD	15	1.8/3.3	vddshv3	Yes	Dual Voltage LVCMOS	PU/PD	0
		uart3_ctsn		1	I									1
		uart5_rxd		2	I									1
		gpio7_16		14	IO									
		Driver off		15	I									
B22	spi2_d1	spi2_d1		0	IO	PD	PD	15	1.8/3.3	vddshv3	Yes	Dual Voltage LVCMOS	PU/PD	0
		uart3_txd		1	O									
		gpio7_15		14	IO									
		Driver off		15	I									
A26	spi2_sclk	spi2_sclk		0	IO	PD	PD	15	1.8/3.3	vddshv3	Yes	Dual Voltage LVCMOS	PU/PD	0
		uart3_rxd		1	I									1
		gpio7_14		14	IO									
		Driver off		15	I									
E20	tclk	tclk		0	I	PU	PU	0	1.8/3.3	vddshv3	Yes	IQ1833	PU/PD	
D23	tdi	tdi		0	I	PU	PU	0	1.8/3.3	vddshv3	Yes	Dual Voltage LVCMOS	PU/PD	
		gpio8_27		14	I									
F19	tdo	tdo		0	O	PU	PU	0	1.8/3.3	vddshv3	Yes	Dual Voltage LVCMOS	PU/PD	
		gpio8_28		14	IO									
F18	tms	tms		0	IO	OFF	OFF	0	1.8/3.3	vddshv3	Yes	Dual Voltage LVCMOS	PU/PD	
D20	trstn	trstn		0	I	PD	PD		1.8/3.3	vddshv3	Yes	Dual Voltage LVCMOS	PU/PD	
E25	uart1_ctsn	uart1_ctsn		0	I	PU	PU	15	1.8/3.3	vddshv4	Yes	Dual Voltage LVCMOS	PU/PD	1
		uart9_rxd		2	I									1
		mmc4_clk		3	IO									1
		gpio7_24		14	IO									
		Driver off		15	I									
C27	uart1_rtsn	uart1_rtsn		0	O	PU	PU	15	1.8/3.3	vddshv4	Yes	Dual Voltage LVCMOS	PU/PD	
		uart9_txd		2	O									
		mmc4_cmd		3	IO									1
		gpio7_25		14	IO									
		Driver off		15	I									
B27	uart1_rxd	uart1_rxd		0	I	PU	PU	15	1.8/3.3	vddshv4	Yes	Dual Voltage LVCMOS	PU/PD	1
		mmc4_sdcd		3	I									1
		gpio7_22		14	IO									
		Driver off		15	I									

Table 4-1. Pin Attributes<sup>(1)</sup> (continued)

BALL NUMBER [1]	BALL NAME [2]	SIGNAL NAME [3]	PN [4]	MUXMODE [5]	TYPE [6]	BALL RESET STATE [7]	BALL RESET REL. STATE [8]	BALL RESET REL. MUXMODE [9]	I/O VOLTAGE VALUE [10]	POWER [11]	HYS [12]	BUFFER TYPE [13]	PULL UP/DOWN TYPE [14]	DSIS [15]
C26	uart1_txd	uart1_txd		0	O	PU	PU	15	1.8/3.3	vddshv4	Yes	Dual Voltage LVCMOS	PU/PD	
		mmc4_sdp		3	I									0
		gpio7_23		14	IO									
		Driver off		15	I									
D27	uart2_ctsn	uart2_ctsn		0	I	PU	PU	15	1.8/3.3	vddshv4	Yes	Dual Voltage LVCMOS	PU/PD	1
		uart3_rxd		2	I									1
		mmc4_dat2		3	IO									1
		uart10_rxd		4	I									1
		uart1_dtrn		5	O									
		gpio1_16		14	IO									
		Driver off		15	I									
C28	uart2_rtsn	uart2_rtsn		0	O	PU	PU	15	1.8/3.3	vddshv4	Yes	Dual Voltage LVCMOS	PU/PD	
		uart3_txd		1	O									
		uart3_irtx		2	O									
		mmc4_dat3		3	IO									1
		uart10_txd		4	O									
		uart1_rin		5	I									1
		gpio1_17		14	IO									
		Driver off		15	I									
D28	uart2_rxd	uart3_ctsn		1	I	PU	PU	15	1.8/3.3	vddshv4	Yes	Dual Voltage LVCMOS	PU/PD	1
		uart3_rctx		2	O									
		mmc4_dat0		3	IO									1
		uart2_rxd		4	I									1
		uart1_dcdn		5	I									1
		gpio7_26		14	IO									
		Driver off		15	I									
D26	uart2_txd	uart2_txd		0	O	PU	PU	15	1.8/3.3	vddshv4	Yes	Dual Voltage LVCMOS	PU/PD	
		uart3_rtsn		1	O									
		uart3_sd		2	O									
		mmc4_dat1		3	IO									1
		uart2_txd		4	O									
		uart1_dsrn		5	I									0
		gpio7_27		14	IO									
		Driver off		15	I									



**Table 4-1. Pin Attributes<sup>(1)</sup> (continued)**

BALL NUMBER [1]	BALL NAME [2]	SIGNAL NAME [3]	PN [4]	MUXMODE [5]	TYPE [6]	BALL RESET STATE [7]	BALL RESET REL. STATE [8]	BALL RESET REL. MUXMODE [9]	I/O VOLTAGE VALUE [10]	POWER [11]	HYS [12]	BUFFER TYPE [13]	PULL UP/DOWN TYPE [14]	DSIS [15]
V2	uart3_rxd	uart3_rxd		0	I	PD	PD	15	1.8/3.3	vddshv9	Yes	Dual Voltage LVCMOS	PU/PD	1
		rmii1_crs		2	I									0
		mii0_rxdv		3	I									0
		vin2a_d1		4	I									0
		vin4b_d1		5	I									0
		spi3_sclk		7	IO									0
		pr1_mii0_rxdv		11	I									0
		pr2_pru1_gpi3		12	I									
		pr2_pru1_gpo3		13	O									
		gpio5_18		14	IO									
		Driver off		15	I									
Y1	uart3_txd	uart3_txd		0	O	PD	PD	15	1.8/3.3	vddshv9	Yes	Dual Voltage LVCMOS	PU/PD	
		rmii1_rxer		2	I									0
		mii0_rxclk		3	I									0
		vin2a_d2		4	I									0
		vin4b_d2		5	I									0
		spi3_d1		7	IO									0
		spi4_cs1		8	IO									1
		pr1_mii_mr0_clk		11	I									0
		pr2_pru1_gpi4		12	I									
		pr2_pru1_gpo4		13	O									
		gpio5_19		14	IO									
Driver off		15	I											
AC12	usb1_dm	usb1_dm		0	IO	OFF	OFF		3.3	vdda33v_us b1		USBPHY		
AD12	usb1_dp	usb1_dp		0	IO	OFF	OFF		3.3	vdda33v_us b1		USBPHY		
AB10	usb1_drvvbus	usb1_drvvbus		0	O	PD	PD	15	1.8/3.3	vddshv6	Yes	Dual Voltage LVCMOS	PU/PD	
		timer16		7	IO									
		gpio6_12		14	IO									
		Driver off		15	I									
AF11	usb2_dm	usb2_dm		0	IO				3.3	vdda33v_us b2	No	USBPHY		
AE11	usb2_dp	usb2_dp		0	IO				3.3	vdda33v_us b2	No	USBPHY		
AC10	usb2_drvvbus	usb2_drvvbus		0	O	PD	PD	15	1.8/3.3	vddshv6	Yes	Dual Voltage LVCMOS	PU/PD	
		timer15		7	IO									
		gpio6_13		14	IO									
		Driver off		15	I									

**Table 4-1. Pin Attributes<sup>(1)</sup> (continued)**

BALL NUMBER [1]	BALL NAME [2]	SIGNAL NAME [3]	PN [4]	MUXMODE [5]	TYPE [6]	BALL RESET STATE [7]	BALL RESET REL. STATE [8]	BALL RESET REL. MUXMODE [9]	I/O VOLTAGE VALUE [10]	POWER [11]	HYS [12]	BUFFER TYPE [13]	PULL UP/DOWN TYPE [14]	DSIS [15]
AF12	usb_rxn0	usb_rxn0		0	I	OFF	OFF		1.8	vdda_usb1		SERDES		
AE12	usb_rxp0	usb_rxp0		0	I	OFF	OFF		1.8	vdda_usb1		SERDES		
AC11	usb_txn0	usb_txn0		0	O				1.8	vdda_usb1		SERDES		
AD11	usb_txp0	usb_txp0		0	O				1.8	vdda_usb1		SERDES		
H13, H14, J17, J18, L7, L8, N10, N13, P11, P12, P13, R11, R16, R19, T13, T16, T19, U13, U16, U8, U9, V16, V8	vdd	vdd			PWR									
K14	vpp	vpp <sup>(8)</sup>			PWR									
AA12	vdda33v_usb1	vdda33v_usb1			PWR									
Y12	vdda33v_usb2	vdda33v_usb2			PWR									
M14	vdda_abe_per	vdda_abe_per			PWR									
P16	vdda_dds	vdda_dds			PWR									
N11	vdda_debug	vdda_debug			PWR									
N12	vdda_dsp_eve	vdda_dsp_eve			PWR									
P15	vdda_gmac_core	vdda_gmac_core			PWR									
R14	vdda_gpu	vdda_gpu			PWR									
Y17	vdda_hdmi	vdda_hdmi			PWR									
R17	vdda_iva	vdda_iva			PWR									
N16	vdda_mpu	vdda_mpu			PWR									
AD16, AE16	vdda_osc	vdda_osc			PWR									
W14	vdda_pcie	vdda_pcie			PWR									
AA17	vdda_pcie0	vdda_pcie0			PWR									
AA16	vdda_pcie1	vdda_pcie1			PWR									
AB13	vdda_rtc	vdda_rtc			PWR									
V13	vdda_sata	vdda_sata			PWR									
AA13	vdda_usb1	vdda_usb1			PWR									
AB12	vdda_usb2	vdda_usb2			PWR									
W12	vdda_usb3	vdda_usb3			PWR									
P14	vdda_video	vdda_video			PWR									
G18, H17, M8, M9, N8, P8, R8, T8, V21, V22, W17, W18	vdds18v	vdds18v			PWR									
AA18, AA19, W21, Y21	vdds18v_dds1	vdds18v_dds1			PWR									
J21, J22, N21, P20, P21	vdds18v_dds2	vdds18v_dds2			PWR									

Table 4-1. Pin Attributes<sup>(1)</sup> (continued)

BALL NUMBER [1]	BALL NAME [2]	SIGNAL NAME [3]	PN [4]	MUXMODE [5]	TYPE [6]	BALL RESET STATE [7]	BALL RESET REL. STATE [8]	BALL RESET REL. MUXMODE [9]	I/O VOLTAGE VALUE [10]	POWER [11]	HYS [12]	BUFFER TYPE [13]	PULL UP/DOWN TYPE [14]	DSIS [15]
E3, E5, G4, G5, H8, H9	vddshv1	vddshv1			PWR									
B6, D10, E10, H10, H11	vddshv2	vddshv2			PWR									
B23, D16, D22, E16, E22, G15, H15, H16, H18, H19	vddshv3	vddshv3			PWR									
C24	vddshv4	vddshv4			PWR									
V12	vddshv5	vddshv5			PWR									
AD5, AD7, AE7, AF5	vddshv6	vddshv6			PWR									
AB6, AB7	vddshv7	vddshv7			PWR									
W8, Y8	vddshv8	vddshv8			PWR									
U10, W4, W5	vddshv9	vddshv9			PWR									
N4, N5, P10, R10, R7, T4, T5	vddshv10	vddshv10			PWR									
J8, K8	vddshv11	vddshv11			PWR									
AA21, AA22, AB21, AB22, AB24, AB25, AC22, AD26, AG20, AG28, AH27, W16, W27	vdds_dds1	vdds_dds1			PWR									
E24, G22, G23, H20, H21, H22, J27, L20, L21, M20, M21, T24, T25	vdds_dds2	vdds_dds2			PWR									
AA7, Y7	vdds_milbp	vdds_milbp			PWR									
J13, K10, K11, K12, K13, L10, L11, L12, M10, M11, M12, M13	vdd_dspeve	vdd_dspeve			PWR									
U11, U12, V10, V11, V14, W10, W11, W13	vdd_gpu	vdd_gpu			PWR									
U18, U19, V18, V19	vdd_iva	vdd_iva			PWR									
K17, K18, L15, L16, L17, L18, L19, M15, M16, M17, M18, N17, N18, P17, P18, R18	vdd_mpu	vdd_mpu			PWR									
AB15	vdd_rtc	vdd_rtc			PWR									

Table 4-1. Pin Attributes<sup>(1)</sup> (continued)

BALL NUMBER [1]	BALL NAME [2]	SIGNAL NAME [3]	PN [4]	MUXMODE [5]	TYPE [6]	BALL RESET STATE [7]	BALL RESET REL. STATE [8]	BALL RESET REL. MUXMODE [9]	I/O VOLTAGE VALUE [10]	POWER [11]	HYS [12]	BUFFER TYPE [13]	PULL UP/DOWN TYPE [14]	DSIS [15]
AG8	vin1a_clk0	vin1a_clk0		0	I	PD	PD	15	1.8/3.3	vddshv6	Yes	Dual Voltage LVCMOS	PU/PD	0
		vout3_d16	No	3	O									
		vout3_fld	No	4	O									
		gpio2_30		14	IO									
		Driver off		15	I									
AE8	vin1a_d0	vin1a_d0		0	I	PD	PD	15	1.8/3.3	vddshv6	Yes	Dual Voltage LVCMOS	PU/PD	0
		vout3_d7	No	3	O									
		vout3_d23	No	4	O									
		uart8_rxd		5	I									1
		ehrpwm1A		10	O									
		gpio3_4		14	IO									
		Driver off		15	I									
AD8	vin1a_d1	vin1a_d1		0	I	PD	PD	15	1.8/3.3	vddshv6	Yes	Dual Voltage LVCMOS	PU/PD	0
		vout3_d6	No	3	O									
		vout3_d22	No	4	O									
		uart8_txd		5	O									
		ehrpwm1B		10	O									
		gpio3_5		14	IO									
		Driver off		15	I									
AG7	vin1a_d2	vin1a_d2		0	I	PD	PD	15	1.8/3.3	vddshv6	Yes	Dual Voltage LVCMOS	PU/PD	0
		vout3_d5	No	3	O									
		vout3_d21	No	4	O									
		uart8_ctsn		5	I									1
		ehrpwm1_tripzone_input		10	IO									0
		gpio3_6		14	IO									
		Driver off		15	I									
AH6	vin1a_d3	vin1a_d3		0	I	PD	PD	15	1.8/3.3	vddshv6	Yes	Dual Voltage LVCMOS	PU/PD	0
		vout3_d4	No	3	O									
		vout3_d20	No	4	O									
		uart8_rtsn		5	O									
		eCAP1_in_PWM1_out		10	IO									0
		pr1_pru0_gpi0		12	I									
		pr1_pru0_gpo0		13	O									
		gpio3_7		14	IO									
		Driver off		15	I									

Table 4-1. Pin Attributes<sup>(1)</sup> (continued)

BALL NUMBER [1]	BALL NAME [2]	SIGNAL NAME [3]	PN [4]	MUXMODE [5]	TYPE [6]	BALL RESET STATE [7]	BALL RESET REL. STATE [8]	BALL RESET REL. MUXMODE [9]	I/O VOLTAGE VALUE [10]	POWER [11]	HYS [12]	BUFFER TYPE [13]	PULL UP/DOWN TYPE [14]	DSIS [15]		
AH3	vin1a_d4	vin1a_d4		0	I	PD	PD	15	1.8/3.3	vddshv6	Yes	Dual Voltage LVCMOS	PU/PD	0		
		vout3_d3	No	3	O											
		vout3_d19	No	4	O											
		ehrpwm1_synci		10	I											0
		pr1_pru0_gpi1		12	I											
		pr1_pru0_gpo1		13	O											
		gpio3_8		14	IO											
		Driver off		15	I											
AH5	vin1a_d5	vin1a_d5		0	I	PD	PD	15	1.8/3.3	vddshv6	Yes	Dual Voltage LVCMOS	PU/PD	0		
		vout3_d2	No	3	O											
		vout3_d18	No	4	O											
		ehrpwm1_synco		10	O											
		pr1_pru0_gpi2		12	I											
		pr1_pru0_gpo2		13	O											
		gpio3_9		14	IO											
		Driver off		15	I											
AG6	vin1a_d6	vin1a_d6		0	I	PD	PD	15	1.8/3.3	vddshv6	Yes	Dual Voltage LVCMOS	PU/PD	0		
		vout3_d1	No	3	O											
		vout3_d17	No	4	O											
		eQEP2A_in		10	I											0
		pr1_pru0_gpi3		12	I											
		pr1_pru0_gpo3		13	O											
		gpio3_10		14	IO											
		Driver off		15	I											
AH4	vin1a_d7	vin1a_d7		0	I	PD	PD	15	1.8/3.3	vddshv6	Yes	Dual Voltage LVCMOS	PU/PD	0		
		vout3_d0	No	3	O											
		vout3_d16	No	4	O											
		eQEP2B_in		10	I											0
		pr1_pru0_gpi4		12	I											
		pr1_pru0_gpo4		13	O											
		gpio3_11		14	IO											
		Driver off		15	I											

Table 4-1. Pin Attributes<sup>(1)</sup> (continued)

BALL NUMBER [1]	BALL NAME [2]	SIGNAL NAME [3]	PN [4]	MUXMODE [5]	TYPE [6]	BALL RESET STATE [7]	BALL RESET REL. STATE [8]	BALL RESET REL. MUXMODE [9]	I/O VOLTAGE VALUE [10]	POWER [11]	HYS [12]	BUFFER TYPE [13]	PULL UP/DOWN TYPE [14]	DSIS [15]	
AG4	vin1a_d8	vin1a_d8		0	I	PD	PD	15	1.8/3.3	vddshv6	Yes	Dual Voltage LVCMOS	PU/PD	0	
		vin1b_d7		1	I									0	
		vout3_d15	No	4	O										0
		kbd_row2		9	I										0
		eQEP2_index		10	IO										0
		pr1_pru0_gpi5		12	I										
		pr1_pru0_gpo5		13	O										
		gpio3_12		14	IO										
Driver off		15	I												
AG2	vin1a_d9	vin1a_d9		0	I	PD	PD	15	1.8/3.3	vddshv6	Yes	Dual Voltage LVCMOS	PU/PD	0	
		vin1b_d6		1	I										0
		vout3_d14	No	4	O										0
		kbd_row3		9	I										0
		eQEP2_strobe		10	IO										0
		pr1_pru0_gpi6		12	I										
		pr1_pru0_gpo6		13	O										
		gpio3_13		14	IO										
Driver off		15	I												
AG3	vin1a_d10	vin1a_d10		0	I	PD	PD	15	1.8/3.3	vddshv6	Yes	Dual Voltage LVCMOS	PU/PD	0	
		vin1b_d5		1	I										0
		vout3_d13	No	4	O										0
		kbd_row4		9	I										0
		pr1_edc_latch0_in		10	I										0
		pr1_pru0_gpi7		12	I										
		pr1_pru0_gpo7		13	O										
		gpio3_14		14	IO										
Driver off		15	I												
AG5	vin1a_d11	vin1a_d11		0	I	PD	PD	15	1.8/3.3	vddshv6	Yes	Dual Voltage LVCMOS	PU/PD	0	
		vin1b_d4		1	I										0
		vout3_d12	No	4	O										0
		gpmc_a23		5	O										
		kbd_row5		9	I										0
		pr1_edc_latch1_in		10	I										0
		pr1_pru0_gpi8		12	I										
		pr1_pru0_gpo8		13	O										
gpio3_15		14	IO												
Driver off		15	I												

Table 4-1. Pin Attributes<sup>(1)</sup> (continued)

BALL NUMBER [1]	BALL NAME [2]	SIGNAL NAME [3]	PN [4]	MUXMODE [5]	TYPE [6]	BALL RESET STATE [7]	BALL RESET REL. STATE [8]	BALL RESET REL. MUXMODE [9]	I/O VOLTAGE VALUE [10]	POWER [11]	HYS [12]	BUFFER TYPE [13]	PULL UP/DOWN TYPE [14]	DSIS [15]
AF2	vin1a_d12	vin1a_d12		0	I	PD	PD	15	1.8/3.3	vddshv6	Yes	Dual Voltage LVCMOS	PU/PD	0
		vin1b_d3		1	I									0
		vout3_d11	No	4	O									
		gpmc_a24		5	O									
		kbd_row6		9	I									0
		pr1_edc_sync0_out		10	O									
		pr1_pru0_gpi9		12	I									
		pr1_pru0_gpo9		13	O									
		gpio3_16		14	IO									
Driver off		15	I											
AF6	vin1a_d13	vin1a_d13		0	I	PD	PD	15	1.8/3.3	vddshv6	Yes	Dual Voltage LVCMOS	PU/PD	0
		vin1b_d2		1	I									0
		vout3_d10	No	4	O									
		gpmc_a25		5	O									
		kbd_row7		9	I									0
		pr1_edc_sync1_out		10	O									
		pr1_pru0_gpi10		12	I									
		pr1_pru0_gpo10		13	O									
		gpio3_17		14	IO									
Driver off		15	I											
AF3	vin1a_d14	vin1a_d14		0	I	PD	PD	15	1.8/3.3	vddshv6	Yes	Dual Voltage LVCMOS	PU/PD	0
		vin1b_d1		1	I									0
		vout3_d9	No	4	O									
		gpmc_a26		5	O									
		kbd_row8		9	I									0
		pr1_edio_latch_in		10	I									0
		pr1_pru0_gpi11		12	I									
		pr1_pru0_gpo11		13	O									
		gpio3_18		14	IO									
Driver off		15	I											

Table 4-1. Pin Attributes<sup>(1)</sup> (continued)

BALL NUMBER [1]	BALL NAME [2]	SIGNAL NAME [3]	PN [4]	MUXMODE [5]	TYPE [6]	BALL RESET STATE [7]	BALL RESET REL. STATE [8]	BALL RESET REL. MUXMODE [9]	I/O VOLTAGE VALUE [10]	POWER [11]	HYS [12]	BUFFER TYPE [13]	PULL UP/DOWN TYPE [14]	DSIS [15]				
AF4	vin1a_d15	vin1a_d15		0	I	PD	PD	15	1.8/3.3	vddshv6	Yes	Dual Voltage LVCMOS	PU/PD	0				
		vin1b_d0		1	I									0				
		vout3_d8	No	4	O													
		gpmc_a27		5	O													
		kbd_col0		9	O													
		pr1_edio_sof		10	O													
		pr1_pru0_gpi12		12	I													
		pr1_pru0_gpo12		13	O													
		gpio3_19		14	IO													
Driver off		15	I															
AF1	vin1a_d16	vin1a_d16		0	I	PD	PD	15	1.8/3.3	vddshv6	Yes	Dual Voltage LVCMOS	PU/PD	0				
		vin1b_d7		1	I									0				
		vout3_d7	No	4	O									0				
		vin3a_d0		6	I									0				
		kbd_col1		9	O									0				
		pr1_edio_data_in0		10	I									0				
		pr1_edio_data_out0		11	O													
		pr1_pru0_gpi13		12	I													
		pr1_pru0_gpo13		13	O													
		gpio3_20		14	IO													
		Driver off		15	I													
		AE3	vin1a_d17	vin1a_d17		0	I	PD	PD	15	1.8/3.3			vddshv6	Yes	Dual Voltage LVCMOS	PU/PD	0
				vin1b_d6		1	I											0
vout3_d6	No			4	O							0						
vin3a_d1				6	I							0						
kbd_col2				9	O							0						
pr1_edio_data_in1				10	I							0						
pr1_edio_data_out1				11	O													
pr1_pru0_gpi14				12	I													
pr1_pru0_gpo14				13	O													
gpio3_21				14	IO													
Driver off				15	I													



Table 4-1. Pin Attributes<sup>(1)</sup> (continued)

BALL NUMBER [1]	BALL NAME [2]	SIGNAL NAME [3]	PN [4]	MUXMODE [5]	TYPE [6]	BALL RESET STATE [7]	BALL RESET REL. STATE [8]	BALL RESET REL. MUXMODE [9]	I/O VOLTAGE VALUE [10]	POWER [11]	HYS [12]	BUFFER TYPE [13]	PULL UP/DOWN TYPE [14]	DSIS [15]	
AE5	vin1a_d18	vin1a_d18		0	I	PD	PD	15	1.8/3.3	vddshv6	Yes	Dual Voltage LVCMOS	PU/PD	0	
		vin1b_d5		1	I									0	
		vout3_d5	No	4	O										0
		vin3a_d2		6	I										0
		kbd_col3		9	O										0
		pr1_edio_data_in2		10	I										0
		pr1_edio_data_out2		11	O										
		pr1_pru0_gpi15		12	I										
		pr1_pru0_gpo15		13	O										
		gpio3_22		14	IO										
Driver off		15	I												
AE1	vin1a_d19	vin1a_d19		0	I	PD	PD	15	1.8/3.3	vddshv6	Yes	Dual Voltage LVCMOS	PU/PD	0	
		vin1b_d4		1	I										0
		vout3_d4	No	4	O										0
		vin3a_d3		6	I										0
		kbd_col4		9	O										0
		pr1_edio_data_in3		10	I										0
		pr1_edio_data_out3		11	O										
		pr1_pru0_gpi16		12	I										
		pr1_pru0_gpo16		13	O										
		gpio3_23		14	IO										
Driver off		15	I												
AE2	vin1a_d20	vin1a_d20		0	I	PD	PD	15	1.8/3.3	vddshv6	Yes	Dual Voltage LVCMOS	PU/PD	0	
		vin1b_d3		1	I										0
		vout3_d3	No	4	O										0
		vin3a_d4		6	I										0
		kbd_col5		9	O										0
		pr1_edio_data_in4		10	I										0
		pr1_edio_data_out4		11	O										
		pr1_pru0_gpi17		12	I										
		pr1_pru0_gpo17		13	O										
		gpio3_24		14	IO										
Driver off		15	I												

Table 4-1. Pin Attributes<sup>(1)</sup> (continued)

BALL NUMBER [1]	BALL NAME [2]	SIGNAL NAME [3]	PN [4]	MUXMODE [5]	TYPE [6]	BALL RESET STATE [7]	BALL RESET REL. STATE [8]	BALL RESET REL. MUXMODE [9]	I/O VOLTAGE VALUE [10]	POWER [11]	HYS [12]	BUFFER TYPE [13]	PULL UP/DOWN TYPE [14]	DSIS [15]
AE6	vin1a_d21	vin1a_d21		0	I	PD	PD	15	1.8/3.3	vddshv6	Yes	Dual Voltage LVCMOS	PU/PD	0
		vin1b_d2		1	I									0
		vout3_d2	No	4	O									0
		vin3a_d5		6	I									0
		kbd_col6		9	O									0
		pr1_edio_data_in5		10	I									0
		pr1_edio_data_out5		11	O									
		pr1_pru0_gpi18		12	I									
		pr1_pru0_gpo18		13	O									
		gpio3_25		14	IO									
Driver off		15	I											
AD2	vin1a_d22	vin1a_d22		0	I	PD	PD	15	1.8/3.3	vddshv6	Yes	Dual Voltage LVCMOS	PU/PD	0
		vin1b_d1		1	I									0
		vout3_d1	No	4	O									0
		vin3a_d6		6	I									0
		kbd_col7		9	O									0
		pr1_edio_data_in6		10	I									0
		pr1_edio_data_out6		11	O									
		pr1_pru0_gpi19		12	I									
		pr1_pru0_gpo19		13	O									
		gpio3_26		14	IO									
Driver off		15	I											
AD3	vin1a_d23	vin1a_d23		0	I	PD	PD	15	1.8/3.3	vddshv6	Yes	Dual Voltage LVCMOS	PU/PD	0
		vin1b_d0		1	I									0
		vout3_d0	No	4	O									0
		vin3a_d7		6	I									0
		kbd_col8		9	O									0
		pr1_edio_data_in7		10	I									0
		pr1_edio_data_out7		11	O									
		pr1_pru0_gpi20		12	I									
		pr1_pru0_gpo20		13	O									
		gpio3_27		14	IO									
Driver off		15	I											

Table 4-1. Pin Attributes<sup>(1)</sup> (continued)

BALL NUMBER [1]	BALL NAME [2]	SIGNAL NAME [3]	PN [4]	MUXMODE [5]	TYPE [6]	BALL RESET STATE [7]	BALL RESET REL. STATE [8]	BALL RESET REL. MUXMODE [9]	I/O VOLTAGE VALUE [10]	POWER [11]	HYS [12]	BUFFER TYPE [13]	PULL UP/DOWN TYPE [14]	DSIS [15]		
AD9	vin1a_de0	vin1a_de0		0	I	PD	PD	15	1.8/3.3	vddshv6	Yes	Dual Voltage LVCMOS	PU/PD	0		
		vin1b_hsync1		1	I										0	
		vout3_d17	No	3	O											
		vout3_de	No	4	O											
		uart7_rxd		5	I											1
		timer16		7	IO											
		spi3_sclk		8	IO											0
		kbd_row0		9	I											0
		eQEP1A_in		10	I											0
		gpio3_0		14	IO											
		Driver off		15	I											
AF9	vin1a_fld0	vin1a_fld0		0	I	PD	PD	15	1.8/3.3	vddshv6	Yes	Dual Voltage LVCMOS	PU/PD	0		
		vin1b_vsync1		1	I											0
		vout3_clk	No	4	O											
		uart7_txd		5	O											
		timer15		7	IO											
		spi3_d1		8	IO											0
		kbd_row1		9	I											0
		eQEP1B_in		10	I											0
		gpio3_1		14	IO											
		Driver off		15	I											
		AE9	vin1a_hsync0	vin1a_hsync0		0	I	PD	PD	15	1.8/3.3			vddshv6	Yes	Dual Voltage LVCMOS
vin1b_fld1				1	I									0		
vout3_hsync	No			4	O											
uart7_ctsn				5	I									1		
timer14				7	IO											
spi3_d0				8	IO									0		
eQEP1_index				10	IO									0		
gpio3_2				14	IO											
Driver off				15	I											

Table 4-1. Pin Attributes<sup>(1)</sup> (continued)

BALL NUMBER [1]	BALL NAME [2]	SIGNAL NAME [3]	PN [4]	MUXMODE [5]	TYPE [6]	BALL RESET STATE [7]	BALL RESET REL. STATE [8]	BALL RESET REL. MUXMODE [9]	I/O VOLTAGE VALUE [10]	POWER [11]	HYS [12]	BUFFER TYPE [13]	PULL UP/DOWN TYPE [14]	DSIS [15]
AF8	vin1a_vsync0	vin1a_vsync0		0	I	PD	PD	15	1.8/3.3	vddshv6	Yes	Dual Voltage LVCMOS	PU/PD	0
		vin1b_de1		1	I									0
		vout3_vsync	No	4	O									
		uart7_rtsn		5	O									
		timer13		7	IO									
		spi3_cs0		8	IO									1
		eQEP1_strobe		10	IO									0
		gpio3_3		14	IO									
Driver off		15	I											
AH7	vin1b_clk1	vin1b_clk1		0	I	PD	PD	15	1.8/3.3	vddshv6	Yes	Dual Voltage LVCMOS	PU/PD	0
		vin3a_clk0		6	I									0
		gpio2_31		14	IO									
		Driver off		15	I									
E1	vin2a_clk0	vin2a_clk0		0	I	PD	PD	15	1.8/3.3	vddshv1	Yes	Dual Voltage LVCMOS	PU/PD	
		vout2_fld	No	4	O									
		emu5		5	O									
		kbd_row0		9	I									0
		eQEP1A_in		10	I									0
		pr1_edio_data_in0		12	I									0
		pr1_edio_data_out0		13	O									
		gpio3_28		14	IO									
		gpmc_a27												
		gpmc_a17												
Driver off		15	I											
F2	vin2a_d0	vin2a_d0		0	I	PD	PD	15	1.8/3.3	vddshv1	Yes	Dual Voltage LVCMOS	PU/PD	0
		vout2_d23	No	4	O									
		emu10		5	O									
		uart9_ctsn		7	I									1
		spi4_d0		8	IO									0
		kbd_row4		9	I									0
		ehrpwm1B		10	O									
		pr1_uart0_rxd		11	I									1
		pr1_edio_data_in5		12	I									0
		pr1_edio_data_out5		13	O									
		gpio4_1		14	IO									
		Driver off		15	I									

Table 4-1. Pin Attributes<sup>(1)</sup> (continued)

BALL NUMBER [1]	BALL NAME [2]	SIGNAL NAME [3]	PN [4]	MUXMODE [5]	TYPE [6]	BALL RESET STATE [7]	BALL RESET REL. STATE [8]	BALL RESET REL. MUXMODE [9]	I/O VOLTAGE VALUE [10]	POWER [11]	HYS [12]	BUFFER TYPE [13]	PULL UP/DOWN TYPE [14]	DSIS [15]				
F3	vin2a_d1	vin2a_d1		0	I	PD	PD	15	1.8/3.3	vddshv1	Yes	Dual Voltage LVCMOS	PU/PD	0				
		vout2_d22	No	4	O													
		emu11		5	O													
		uart9_rtsn		7	O													
		spi4_cs0		8	IO											1		
		kbd_row5		9	I											0		
		ehrpwm1_tripzone_input		10	IO											0		
		pr1_uart0_txd		11	O													
		pr1_edio_data_in6		12	I												0	
		pr1_edio_data_out6		13	O													
		gpio4_2		14	IO													
		Driver off		15	I													
		D1	vin2a_d2	vin2a_d2		0	I	PD	PD	15	1.8/3.3			vddshv1	Yes	Dual Voltage LVCMOS	PU/PD	0
vout2_d21	No			4	O													
emu12				5	O													
uart10_rxd				8	I									1				
kbd_row6				9	I									0				
eCAP1_in_PWM1_out				10	IO									0				
pr1_ecap0_ecap_capin_apwm_o				11	IO									0				
pr1_edio_data_in7				12	I									0				
pr1_edio_data_out7				13	O													
gpio4_3				14	IO													
Driver off				15	I													
E2	vin2a_d3			vin2a_d3		0	I	PD	PD	15	1.8/3.3	vddshv1	Yes	Dual Voltage LVCMOS	PU/PD			0
				vout2_d20	No	4	O											
		emu13		5	O													
		uart10_txd		8	O													
		kbd_col0		9	O													
		ehrpwm1_synci		10	I											0		
		pr1_edc_latch0_in		11	I											0		
		pr1_pru1_gpi0		12	I													
		pr1_pru1_gpo0		13	O													
		gpio4_4		14	IO													
		Driver off		15	I													

Table 4-1. Pin Attributes<sup>(1)</sup> (continued)

BALL NUMBER [1]	BALL NAME [2]	SIGNAL NAME [3]	PN [4]	MUXMODE [5]	TYPE [6]	BALL RESET STATE [7]	BALL RESET REL. STATE [8]	BALL RESET REL. MUXMODE [9]	I/O VOLTAGE VALUE [10]	POWER [11]	HYS [12]	BUFFER TYPE [13]	PULL UP/DOWN TYPE [14]	DSIS [15]		
D2	vin2a_d4	vin2a_d4		0	I	PD	PD	15	1.8/3.3	vddshv1	Yes	Dual Voltage LVCMOS	PU/PD	0		
		vout2_d19	No	4	O											
		emu14		5	O											
		uart10_ctsn		8	I											1
		kbd_col1		9	O											
		ehrpwm1_synco		10	O											
		pr1_edc_sync0_out		11	O											
		pr1_pru1_gpi1		12	I											
		pr1_pru1_gpo1		13	O											
		gpio4_5		14	IO											
Driver off		15	I													
F4	vin2a_d5	vin2a_d5		0	I	PD	PD	15	1.8/3.3	vddshv1	Yes	Dual Voltage LVCMOS	PU/PD	0		
		vout2_d18	No	4	O											
		emu15		5	O											
		uart10_rtsn		8	O											
		kbd_col2		9	O											
		eQEP2A_in		10	I											0
		pr1_edio_sof		11	O											
		pr1_pru1_gpi2		12	I											
		pr1_pru1_gpo2		13	O											
		gpio4_6		14	IO											
Driver off		15	I													
C1	vin2a_d6	vin2a_d6		0	I	PD	PD	15	1.8/3.3	vddshv1	Yes	Dual Voltage LVCMOS	PU/PD	0		
		vout2_d17	No	4	O											
		emu16		5	O											
		mii1_rxd1		8	I											0
		kbd_col3		9	O											
		eQEP2B_in		10	I											0
		pr1_mii_mt1_clk		11	I											0
		pr1_pru1_gpi3		12	I											
		pr1_pru1_gpo3		13	O											
		gpio4_7		14	IO											
Driver off		15	I													

Table 4-1. Pin Attributes<sup>(1)</sup> (continued)

BALL NUMBER [1]	BALL NAME [2]	SIGNAL NAME [3]	PN [4]	MUXMODE [5]	TYPE [6]	BALL RESET STATE [7]	BALL RESET REL. STATE [8]	BALL RESET REL. MUXMODE [9]	I/O VOLTAGE VALUE [10]	POWER [11]	HYS [12]	BUFFER TYPE [13]	PULL UP/DOWN TYPE [14]	DSIS [15]			
E4	vin2a_d7	vin2a_d7		0	I	PD	PD	15	1.8/3.3	vddshv1	Yes	Dual Voltage LVCMOS	PU/PD	0			
		vout2_d16	No	4	O												
		emu17		5	O												
		mii1_rxd2		8	I											0	
		kbd_col4		9	O												
		eQEP2_index		10	IO												0
		pr1_mii1_txen		11	O												
		pr1_pru1_gpi4		12	I												
		pr1_pru1_gpo4		13	O												
		gpio4_8		14	IO												
Driver off		15	I														
F5	vin2a_d8	vin2a_d8		0	I	PD	PD	15	1.8/3.3	vddshv1	Yes	Dual Voltage LVCMOS	PU/PD	0			
		vout2_d15	No	4	O												
		emu18		5	O												
		mii1_rxd3		8	I											0	
		kbd_col5		9	O												
		eQEP2_strobe		10	IO												0
		pr1_mii1_txd3		11	O												
		pr1_pru1_gpi5		12	I												
		pr1_pru1_gpo5		13	O												
		gpio4_9		14	IO												
gpmc_a26		14	IO														
Driver off		15	I														
E6	vin2a_d9	vin2a_d9		0	I	PD	PD	15	1.8/3.3	vddshv1	Yes	Dual Voltage LVCMOS	PU/PD	0			
		vout2_d14	No	4	O												
		emu19		5	O												
		mii1_rxd0		8	I											0	
		kbd_col6		9	O												
		ehrpwm2A		10	O												
		pr1_mii1_txd2		11	O												
		pr1_pru1_gpi6		12	I												
		pr1_pru1_gpo6		13	O												
		gpio4_10		14	IO												
gpmc_a25		14	IO														
Driver off		15	I														

Table 4-1. Pin Attributes<sup>(1)</sup> (continued)

BALL NUMBER [1]	BALL NAME [2]	SIGNAL NAME [3]	PN [4]	MUXMODE [5]	TYPE [6]	BALL RESET STATE [7]	BALL RESET REL. STATE [8]	BALL RESET REL. MUXMODE [9]	I/O VOLTAGE VALUE [10]	POWER [11]	HYS [12]	BUFFER TYPE [13]	PULL UP/DOWN TYPE [14]	DSIS [15]
D3	vin2a_d10	vin2a_d10		0	I	PD	PD	15	1.8/3.3	vddshv1	Yes	Dual Voltage LVCMOS	PU/PD	0
		mdio_mclk		3	O									1
		vout2_d13	No	4	O									
		kbd_col7		9	O									
		ehrpwm2B		10	O									
		pr1_mdio_mdclk		11	O									
		pr1_pru1_gpi7		12	I									
		pr1_pru1_gpo7		13	O									
		gpio4_11 gpmc_a24 Driver off		14 15	IO I									
F6	vin2a_d11	vin2a_d11		0	I	PD	PD	15	1.8/3.3	vddshv1	Yes	Dual Voltage LVCMOS	PU/PD	0
		mdio_d		3	IO									1
		vout2_d12	No	4	O									
		kbd_row7		9	I									0
		ehrpwm2_tripzone_input		10	IO									0
		pr1_mdio_data		11	IO									1
		pr1_pru1_gpi8		12	I									
		pr1_pru1_gpo8		13	O									
		gpio4_12 gpmc_a23 Driver off		14 15	IO I									
D5	vin2a_d12	vin2a_d12		0	I	PD	PD	15	1.8/3.3	vddshv1	Yes	Dual Voltage LVCMOS	PU/PD	0
		rgmii1_txc		3	O									
		vout2_d11	No	4	O									
		mii1_rxclk		8	I									0
		kbd_col8		9	O									
		eCAP2_in_PWM2_out		10	IO									0
		pr1_mii1_txd1		11	O									
		pr1_pru1_gpi9		12	I									
		pr1_pru1_gpo9 gpio4_13 Driver off		13 14 15	O IO I									



**Table 4-1. Pin Attributes<sup>(1)</sup> (continued)**

BALL NUMBER [1]	BALL NAME [2]	SIGNAL NAME [3]	PN [4]	MUXMODE [5]	TYPE [6]	BALL RESET STATE [7]	BALL RESET REL. STATE [8]	BALL RESET REL. MUXMODE [9]	I/O VOLTAGE VALUE [10]	POWER [11]	HYS [12]	BUFFER TYPE [13]	PULL UP/DOWN TYPE [14]	DSIS [15]			
C2	vin2a_d13	vin2a_d13		0	I	PD	PD	15	1.8/3.3	vddshv1	Yes	Dual Voltage LVCMOS	PU/PD	0			
		rgmii1_txctl		3	O												
		vout2_d10	No	4	O												
		mii1_rxdv		8	I											0	
		kbd_row8		9	I												0
		eQEP3A_in		10	I												0
		pr1_mii1_txd0		11	O												
		pr1_pru1_gpi10		12	I												
		pr1_pru1_gpo10		13	O												
		gpio4_14		14	IO												
Driver off		15	I														
C3	vin2a_d14	vin2a_d14		0	I	PD	PD	15	1.8/3.3	vddshv1	Yes	Dual Voltage LVCMOS	PU/PD	0			
		rgmii1_txd3		3	O												
		vout2_d9	No	4	O												
		mii1_txclk		8	I											0	
		eQEP3B_in		10	I												0
		pr1_mii_mr1_clk		11	I												0
		pr1_pru1_gpi11		12	I												
		pr1_pru1_gpo11		13	O												
		gpio4_15		14	IO												
		Driver off		15	I												
C4	vin2a_d15	vin2a_d15		0	I	PD	PD	15	1.8/3.3	vddshv1	Yes	Dual Voltage LVCMOS	PU/PD	0			
		rgmii1_txd2		3	O												
		vout2_d8	No	4	O												
		mii1_txd0		8	O												
		eQEP3_index		10	IO												0
		pr1_mii1_rxdv		11	I												0
		pr1_pru1_gpi12		12	I												
		pr1_pru1_gpo12		13	O												
		gpio4_16		14	IO												
		Driver off		15	I												

Table 4-1. Pin Attributes<sup>(1)</sup> (continued)

BALL NUMBER [1]	BALL NAME [2]	SIGNAL NAME [3]	PN [4]	MUXMODE [5]	TYPE [6]	BALL RESET STATE [7]	BALL RESET REL. STATE [8]	BALL RESET REL. MUXMODE [9]	I/O VOLTAGE VALUE [10]	POWER [11]	HYS [12]	BUFFER TYPE [13]	PULL UP/DOWN TYPE [14]	DSIS [15]
B2	vin2a_d16	vin2a_d16		0	I	PD	PD	15	1.8/3.3	vddshv1	Yes	Dual Voltage LVCMOS	PU/PD	0
		vin2b_d7		2	I									0
		rgmii1_txd1		3	O									
		vout2_d7	No	4	O									
		vin3a_d8		6	I									
		mii1_txd1		8	O									
		eQEP3_strobe		10	IO									
		pr1_mii1_rxd3		11	I									
		pr1_prui_gpi13		12	I									
		pr1_prui_gpo13		13	O									
		gpio4_24		14	IO									
		Driver off		15	I									
		D6	vin2a_d17	vin2a_d17		0	I	PD	PD	15	1.8/3.3			vddshv1
vin2b_d6				2	I							0		
rgmii1_txd0				3	O									
vout2_d6	No			4	O									
vin3a_d9				6	I									
mii1_txd2				8	O									
ehrpwm3A				10	O									
pr1_mii1_rxd2				11	I									
pr1_prui_gpi14				12	I									
pr1_prui_gpo14				13	O									
gpio4_25				14	IO									
Driver off				15	I									
C5	vin2a_d18			vin2a_d18		0	I	PD	PD	15	1.8/3.3	vddshv1	Yes	Dual Voltage LVCMOS
		vin2b_d5		2	I							0		
		rgmii1_rxc		3	I							0		
		vout2_d5	No	4	O							0		
		vin3a_d10		6	I							0		
		mii1_txd3		8	O									
		ehrpwm3B		10	O									
		pr1_mii1_rxd1		11	I							0		
		pr1_prui_gpi15		12	I									
		pr1_prui_gpo15		13	O									
		gpio4_26		14	IO									
		Driver off		15	I									

**Table 4-1. Pin Attributes<sup>(1)</sup> (continued)**

BALL NUMBER [1]	BALL NAME [2]	SIGNAL NAME [3]	PN [4]	MUXMODE [5]	TYPE [6]	BALL RESET STATE [7]	BALL RESET REL. STATE [8]	BALL RESET REL. MUXMODE [9]	I/O VOLTAGE VALUE [10]	POWER [11]	HYS [12]	BUFFER TYPE [13]	PULL UP/DOWN TYPE [14]	DSIS [15]				
A3	vin2a_d19	vin2a_d19		0	I	PD	PD	15	1.8/3.3	vddshv1	Yes	Dual Voltage LVCMOS	PU/PD	0				
		vin2b_d4		2	I									0				
		rgmii1_rxctl		3	I									0				
		vout2_d4	No	4	O									0				
		vin3a_d11		6	I									0				
		mii1_txer		8	O									0				
		ehrpwm3_tripzone_input		10	IO									0				
		pr1_mii1_rxd0		11	I									0				
		pr1_pru1_gpi16		12	I													
		pr1_pru1_gpo16		13	O													
		gpio4_27		14	IO													
		Driver off		15	I													
		B3	vin2a_d20	vin2a_d20		0	I	PD	PD	15	1.8/3.3			vddshv1	Yes	Dual Voltage LVCMOS	PU/PD	0
				vin2b_d3		2	I											0
rgmii1_rxd3				3	I							0						
vout2_d3	No			4	O							0						
vin3a_de0				5	I							0						
vin3a_d12				6	I							0						
mii1_rxer				8	I							0						
eCAP3_in_PWM3_out				10	IO							0						
pr1_mii1_rxer				11	I							0						
pr1_pru1_gpi17				12	I													
pr1_pru1_gpo17				13	O													
gpio4_28				14	IO													
Driver off				15	I													
B4	vin2a_d21			vin2a_d21		0	I	PD	PD	15	1.8/3.3	vddshv1	Yes	Dual Voltage LVCMOS	PU/PD			0
		vin2b_d2		2	I							0						
		rgmii1_rxd2		3	I							0						
		vout2_d2	No	4	O							0						
		vin3a_fld0		5	I							0						
		vin3a_d13		6	I							0						
		mii1_col		8	I							0						
		pr1_mii1_rlink		11	I							0						
		pr1_pru1_gpi18		12	I													
		pr1_pru1_gpo18		13	O													
		gpio4_29		14	IO													
		Driver off		15	I													

Table 4-1. Pin Attributes<sup>(1)</sup> (continued)

BALL NUMBER [1]	BALL NAME [2]	SIGNAL NAME [3]	PN [4]	MUXMODE [5]	TYPE [6]	BALL RESET STATE [7]	BALL RESET REL. STATE [8]	BALL RESET REL. MUXMODE [9]	I/O VOLTAGE VALUE [10]	POWER [11]	HYS [12]	BUFFER TYPE [13]	PULL UP/DOWN TYPE [14]	DSIS [15]				
B5	vin2a_d22	vin2a_d22		0	I	PD	PD	15	1.8/3.3	vddshv1	Yes	Dual Voltage LVCMOS	PU/PD	0				
		vin2b_d1		2	I									0				
		rgmii1_rxd1		3	I									0				
		vout2_d1	No	4	O									0				
		vin3a_hsync0		5	I									0				
		vin3a_d14		6	I									0				
		mii1_crs		8	I									0				
		pr1_mii1_col		11	I									0				
		pr1_pru1_gpi19		12	I													
		pr1_pru1_gpo19		13	O													
		gpio4_30		14	IO													
		Driver off		15	I													
		A4	vin2a_d23	vin2a_d23		0	I	PD	PD	15	1.8/3.3			vddshv1	Yes	Dual Voltage LVCMOS	PU/PD	0
				vin2b_d0		2	I											0
rgmii1_rxd0				3	I							0						
vout2_d0	No			4	O							0						
vin3a_vsync0				5	I							0						
vin3a_d15				6	I							0						
mii1_txen				8	O							0						
pr1_mii1_crs				11	I							0						
pr1_pru1_gpi20				12	I													
pr1_pru1_gpo20				13	O													
gpio4_31				14	IO													
Driver off				15	I													
G2	vin2a_de0			vin2a_de0		0	I	PD	PD	15	1.8/3.3	vddshv1	Yes	Dual Voltage LVCMOS	PU/PD			
				vin2a_fld0		1	I											
		vin2b_fld1		2	I													
		vin2b_de1		3	I													
		vout2_de	No	4	O													
		emu6		5	O													
		kbd_row1		9	I							0						
		eQEP1B_in		10	I							0						
		pr1_edio_data_in1		12	I							0						
		pr1_edio_data_out1		13	O													
		gpio3_29		14	IO													
		Driver off		15	I													

Table 4-1. Pin Attributes<sup>(1)</sup> (continued)

BALL NUMBER [1]	BALL NAME [2]	SIGNAL NAME [3]	PN [4]	MUXMODE [5]	TYPE [6]	BALL RESET STATE [7]	BALL RESET REL. STATE [8]	BALL RESET REL. MUXMODE [9]	I/O VOLTAGE VALUE [10]	POWER [11]	HYS [12]	BUFFER TYPE [13]	PULL UP/DOWN TYPE [14]	DSIS [15]				
H7	vin2a_fld0	vin2a_fld0		0	I	PD	PD	15	1.8/3.3	vddshv1	Yes	Dual Voltage LVCMOS	PU/PD					
		vin2b_clk1		2	I													
		vout2_clk	No	4	O													
		emu7		5	O													
		eQEP1_index		10	IO											0		
		pr1_edio_data_in2		12	I											0		
		pr1_edio_data_out2		13	O													
		gpio3_30 gpmc_a27 gpmc_a18 Driver off		14 15	IO I													
G1	vin2a_hsync0	vin2a_hsync0		0	I	PD	PD	15	1.8/3.3	vddshv1	Yes	Dual Voltage LVCMOS	PU/PD					
		vin2b_hsync1		3	I													
		vout2_hsync	No	4	O													
		emu8		5	O													
		uart9_rxd		7	I											1		
		spi4_sclk		8	IO											0		
		kbd_row2		9	I											0		
		eQEP1_strobe		10	IO											0		
		pr1_uart0_cts_n		11	I											1		
		pr1_edio_data_in3		12	I											0		
		pr1_edio_data_out3		13	O													
		gpio3_31 gpmc_a27 Driver off		14 15	IO I													
		G6	vin2a_vsync0	vin2a_vsync0		0	I	PD	PD	15	1.8/3.3			vddshv1	Yes	Dual Voltage LVCMOS	PU/PD	
				vin2b_vsync1		3	I											
vout2_vsync	No			4	O													
emu9				5	O													
uart9_txd				7	O													
spi4_d1				8	IO									0				
kbd_row3				9	I									0				
ehrpwm1A				10	O													
pr1_uart0_rts_n				11	O													
pr1_edio_data_in4				12	I									0				
pr1_edio_data_out4				13	O													
gpio4_0 Driver off				14 15	IO I													

Table 4-1. Pin Attributes<sup>(1)</sup> (continued)

BALL NUMBER [1]	BALL NAME [2]	SIGNAL NAME [3]	PN [4]	MUXMODE [5]	TYPE [6]	BALL RESET STATE [7]	BALL RESET REL. STATE [8]	BALL RESET REL. MUXMODE [9]	I/O VOLTAGE VALUE [10]	POWER [11]	HYS [12]	BUFFER TYPE [13]	PULL UP/DOWN TYPE [14]	DSIS [15]
D11	vout1_clk	vout1_clk	No	0	O	PD	PD	15	1.8/3.3	vddshv2	Yes	Dual Voltage LVCMOS	PU/PD	
		vin4a_fld0		3	I									0
		vin3a_fld0		4	I									0
		spi3_cs0		8	IO									1
		gpio4_19		14	IO									
		Driver off		15	I									
F11	vout1_d0	vout1_d0	No	0	O	PD	PD	15	1.8/3.3	vddshv2	Yes	Dual Voltage LVCMOS	PU/PD	
		uart5_rxd		2	I									1
		vin4a_d16		3	I									0
		vin3a_d16		4	I									0
		spi3_cs2		8	IO									1
		pr1_uart0_cts_n		10	I									1
		pr2_pru1_gpi18		12	I									
		pr2_pru1_gpo18		13	O									
		gpio8_0		14	IO									
		Driver off		15	I									
G10	vout1_d1	vout1_d1	No	0	O	PD	PD	15	1.8/3.3	vddshv2	Yes	Dual Voltage LVCMOS	PU/PD	
		uart5_txd		2	O									
		vin4a_d17		3	I									0
		vin3a_d17		4	I									0
		pr1_uart0_rts_n		10	O									
		pr2_pru1_gpi19		12	I									
		pr2_pru1_gpo19		13	O									
		gpio8_1		14	IO									
Driver off		15	I											
F10	vout1_d2	vout1_d2	No	0	O	PD	PD	15	1.8/3.3	vddshv2	Yes	Dual Voltage LVCMOS	PU/PD	
		emu2		2	O									
		vin4a_d18		3	I									0
		vin3a_d18		4	I									0
		obs0		5	O									
		obs16		6	O									
		obs_irq1		7	O									
		pr1_uart0_rxd		10	I									1
		pr2_pru1_gpi20		12	I									
		pr2_pru1_gpo20		13	O									
		gpio8_2		14	IO									
		Driver off		15	I									

Table 4-1. Pin Attributes<sup>(1)</sup> (continued)

BALL NUMBER [1]	BALL NAME [2]	SIGNAL NAME [3]	PN [4]	MUXMODE [5]	TYPE [6]	BALL RESET STATE [7]	BALL RESET REL. STATE [8]	BALL RESET REL. MUXMODE [9]	I/O VOLTAGE VALUE [10]	POWER [11]	HYS [12]	BUFFER TYPE [13]	PULL UP/DOWN TYPE [14]	DSIS [15]			
G11	vout1_d3	vout1_d3	No	0	O	PD	PD	15	1.8/3.3	vddshv2	Yes	Dual Voltage LVCMOS	PU/PD				
		emu5		2	O												
		vin4a_d19		3	I										0		
		vin3a_d19		4	I										0		
		obs1		5	O												
		obs17		6	O												
		obs_dmarq1		7	O												
		pr1_uart0_txd		10	O												
		pr2_pru0_gpi0		12	I												
		pr2_pru0_gpo0		13	O												
		gpio8_3		14	IO												
		Driver off		15	I												
E9	vout1_d4	vout1_d4	No	0	O	PD	PD	15	1.8/3.3	vddshv2	Yes	Dual Voltage LVCMOS	PU/PD				
		emu6		2	O												
		vin4a_d20		3	I										0		
		vin3a_d20		4	I										0		
		obs2		5	O												
		obs18		6	O												
		pr1_ecap0_ecap_capin_apwm_o		10	IO											0	
		pr2_pru0_gpi1		12	I												
		pr2_pru0_gpo1		13	O												
		gpio8_4		14	IO												
		Driver off		15	I												
		F9	vout1_d5	vout1_d5	No	0	O	PD	PD	15	1.8/3.3			vddshv2	Yes	Dual Voltage LVCMOS	PU/PD
emu7				2	O												
vin4a_d21				3	I								0				
vin3a_d21				4	I								0				
obs3				5	O												
obs19				6	O												
pr2_edc_latch0_in				10	I									0			
pr2_pru0_gpi2				12	I												
pr2_pru0_gpo2				13	O												
gpio8_5				14	IO												
Driver off				15	I												

Table 4-1. Pin Attributes<sup>(1)</sup> (continued)

BALL NUMBER [1]	BALL NAME [2]	SIGNAL NAME [3]	PN [4]	MUXMODE [5]	TYPE [6]	BALL RESET STATE [7]	BALL RESET REL. STATE [8]	BALL RESET REL. MUXMODE [9]	I/O VOLTAGE VALUE [10]	POWER [11]	HYS [12]	BUFFER TYPE [13]	PULL UP/DOWN TYPE [14]	DSIS [15]		
F8	vout1_d6	vout1_d6	No	0	O	PD	PD	15	1.8/3.3	vddshv2	Yes	Dual Voltage LVCMOS	PU/PD			
		emu8		2	O											
		vin4a_d22		3	I										0	
		vin3a_d22		4	I										0	
		obs4		5	O											
		obs20		6	O											
		pr2_edc_latch1_in		10	I											0
		pr2_pru0_gpi3		12	I											
		pr2_pru0_gpo3		13	O											
		gpio8_6		14	IO											
Driver off		15	I													
E7	vout1_d7	vout1_d7	No	0	O	PD	PD	15	1.8/3.3	vddshv2	Yes	Dual Voltage LVCMOS	PU/PD			
		emu9		2	O											
		vin4a_d23		3	I										0	
		vin3a_d23		4	I										0	
		pr2_edc_sync0_out		10	O											
		pr2_pru0_gpi4		12	I											
		pr2_pru0_gpo4		13	O											
		gpio8_7		14	IO											
		Driver off		15	I											
		E8	vout1_d8	vout1_d8	No	0	O	PD	PD	15	1.8/3.3			vddshv2	Yes	Dual Voltage LVCMOS
uart6_rxd				2	I								1			
vin4a_d8				3	I								0			
vin3a_d8				4	I								0			
pr2_edc_sync1_out				10	O											
pr2_pru0_gpi5				12	I											
pr2_pru0_gpo5				13	O											
gpio8_8				14	IO											
Driver off				15	I											



Table 4-1. Pin Attributes<sup>(1)</sup> (continued)

BALL NUMBER [1]	BALL NAME [2]	SIGNAL NAME [3]	PN [4]	MUXMODE [5]	TYPE [6]	BALL RESET STATE [7]	BALL RESET REL. STATE [8]	BALL RESET REL. MUXMODE [9]	I/O VOLTAGE VALUE [10]	POWER [11]	HYS [12]	BUFFER TYPE [13]	PULL UP/DOWN TYPE [14]	DSIS [15]		
D9	vout1_d9	vout1_d9	No	0	O	PD	PD	15	1.8/3.3	vddshv2	Yes	Dual Voltage LVCMOS	PU/PD			
		uart6_txd		2	O											
		vin4a_d9		3	I										0	
		vin3a_d9		4	I										0	
		pr2_edio_latch_in		10	I										0	
		pr2_pru0_gpi6		12	I											
		pr2_pru0_gpo6		13	O											
		gpio8_9		14	IO											
Driver off		15	I													
D7	vout1_d10	vout1_d10	No	0	O	PD	PD	15	1.8/3.3	vddshv2	Yes	Dual Voltage LVCMOS	PU/PD			
		emu3		2	O											
		vin4a_d10		3	I										0	
		vin3a_d10		4	I										0	
		obs5		5	O											
		obs21		6	O											
		obs_irq2		7	O											
		pr2_edio_sof		10	O											
		pr2_pru0_gpi7		12	I											
		pr2_pru0_gpo7		13	O											
		gpio8_10		14	IO											
		Driver off		15	I											
		D8	vout1_d11	vout1_d11	No	0	O	PD	PD	15	1.8/3.3			vddshv2	Yes	Dual Voltage LVCMOS
emu10				2	O											
vin4a_d11				3	I								0			
vin3a_d11				4	I								0			
obs6				5	O											
obs22				6	O											
obs_dmarq2				7	O											
pr2_uart0_cts_n				10	I									1		
pr2_pru0_gpi8				12	I											
pr2_pru0_gpo8				13	O											
gpio8_11				14	IO											
Driver off				15	I											

Table 4-1. Pin Attributes<sup>(1)</sup> (continued)

BALL NUMBER [1]	BALL NAME [2]	SIGNAL NAME [3]	PN [4]	MUXMODE [5]	TYPE [6]	BALL RESET STATE [7]	BALL RESET REL. STATE [8]	BALL RESET REL. MUXMODE [9]	I/O VOLTAGE VALUE [10]	POWER [11]	HYS [12]	BUFFER TYPE [13]	PULL UP/DOWN TYPE [14]	DSIS [15]		
A5	vout1_d12	vout1_d12	No	0	O	PD	PD	15	1.8/3.3	vddshv2	Yes	Dual Voltage LVCMOS	PU/PD			
		emu11		2	O											
		vin4a_d12		3	I										0	
		vin3a_d12		4	I										0	
		obs7		5	O											
		obs23		6	O											
		pr2_uart0_rts_n		10	O											
		pr2_pru0_gpi9		12	I											
		pr2_pru0_gpo9		13	O											
		gpio8_12		14	IO											
Driver off		15	I													
C6	vout1_d13	vout1_d13	No	0	O	PD	PD	15	1.8/3.3	vddshv2	Yes	Dual Voltage LVCMOS	PU/PD			
		emu12		2	O											
		vin4a_d13		3	I										0	
		vin3a_d13		4	I										0	
		obs8		5	O											
		obs24		6	O											
		pr2_uart0_rxd		10	I											1
		pr2_pru0_gpi10		12	I											
		pr2_pru0_gpo10		13	O											
		gpio8_13		14	IO											
Driver off		15	I													
C8	vout1_d14	vout1_d14	No	0	O	PD	PD	15	1.8/3.3	vddshv2	Yes	Dual Voltage LVCMOS	PU/PD			
		emu13		2	O											
		vin4a_d14		3	I										0	
		vin3a_d14		4	I										0	
		obs9		5	O											
		obs25		6	O											
		pr2_uart0_txd		10	O											
		pr2_pru0_gpi11		12	I											
		pr2_pru0_gpo11		13	O											
		gpio8_14		14	IO											
Driver off		15	I													

Table 4-1. Pin Attributes<sup>(1)</sup> (continued)

BALL NUMBER [1]	BALL NAME [2]	SIGNAL NAME [3]	PN [4]	MUXMODE [5]	TYPE [6]	BALL RESET STATE [7]	BALL RESET REL. STATE [8]	BALL RESET REL. MUXMODE [9]	I/O VOLTAGE VALUE [10]	POWER [11]	HYS [12]	BUFFER TYPE [13]	PULL UP/DOWN TYPE [14]	DSIS [15]
C7	vout1_d15	vout1_d15	No	0	O	PD	PD	15	1.8/3.3	vddshv2	Yes	Dual Voltage LVCMOS	PU/PD	
		emu14		2	O									
		vin4a_d15		3	I									0
		vin3a_d15		4	I									0
		obs10		5	O									
		obs26		6	O									
		pr2_ecap0_ecap_capin_apwm_o		10	IO									0
		pr2_pru0_gpi12		12	I									
		pr2_pru0_gpo12		13	O									
		gpio8_15		14	IO									
Driver off		15	I											
B7	vout1_d16	vout1_d16	No	0	O	PD	PD	15	1.8/3.3	vddshv2	Yes	Dual Voltage LVCMOS	PU/PD	
		uart7_rxd		2	I									1
		vin4a_d0		3	I									0
		vin3a_d0		4	I									0
		pr2_edio_data_in0		10	I									0
		pr2_edio_data_out0		11	O									
		pr2_pru0_gpi13		12	I									
		pr2_pru0_gpo13		13	O									
		gpio8_16		14	IO									
		Driver off		15	I									
B8	vout1_d17	vout1_d17	No	0	O	PD	PD	15	1.8/3.3	vddshv2	Yes	Dual Voltage LVCMOS	PU/PD	
		uart7_txd		2	O									
		vin4a_d1		3	I									0
		vin3a_d1		4	I									0
		pr2_edio_data_in1		10	I									0
		pr2_edio_data_out1		11	O									
		pr2_pru0_gpi14		12	I									
		pr2_pru0_gpo14		13	O									
		gpio8_17		14	IO									
		Driver off		15	I									

**Table 4-1. Pin Attributes<sup>(1)</sup> (continued)**

BALL NUMBER [1]	BALL NAME [2]	SIGNAL NAME [3]	PN [4]	MUXMODE [5]	TYPE [6]	BALL RESET STATE [7]	BALL RESET REL. STATE [8]	BALL RESET REL. MUXMODE [9]	I/O VOLTAGE VALUE [10]	POWER [11]	HYS [12]	BUFFER TYPE [13]	PULL UP/DOWN TYPE [14]	DSIS [15]		
A7	vout1_d18	vout1_d18	No	0	O	PD	PD	15	1.8/3.3	vddshv2	Yes	Dual Voltage LVCMOS	PU/PD			
		emu4		2	O											
		vin4a_d2		3	I										0	
		vin3a_d2		4	I										0	
		obs11		5	O											
		obs27		6	O											
		pr2_edio_data_in2		10	I											0
		pr2_edio_data_out2		11	O											
		pr2_pru0_gpi15		12	I											
		pr2_pru0_gpo15		13	O											
		gpio8_18		14	IO											
		Driver off		15	I											
A8	vout1_d19	vout1_d19	No	0	O	PD	PD	15	1.8/3.3	vddshv2	Yes	Dual Voltage LVCMOS	PU/PD			
		emu15		2	O											
		vin4a_d3		3	I										0	
		vin3a_d3		4	I										0	
		obs12		5	O											
		obs28		6	O											
		pr2_edio_data_in3		10	I											0
		pr2_edio_data_out3		11	O											
		pr2_pru0_gpi16		12	I											
		pr2_pru0_gpo16		13	O											
		gpio8_19		14	IO											
		Driver off		15	I											
C9	vout1_d20	vout1_d20	No	0	O	PD	PD	15	1.8/3.3	vddshv2	Yes	Dual Voltage LVCMOS	PU/PD			
		emu16		2	O											
		vin4a_d4		3	I										0	
		vin3a_d4		4	I										0	
		obs13		5	O											
		obs29		6	O											
		pr2_edio_data_in4		10	I											0
		pr2_edio_data_out4		11	O											
		pr2_pru0_gpi17		12	I											
		pr2_pru0_gpo17		13	O											
		gpio8_20		14	IO											
		Driver off		15	I											

Table 4-1. Pin Attributes<sup>(1)</sup> (continued)

BALL NUMBER [1]	BALL NAME [2]	SIGNAL NAME [3]	PN [4]	MUXMODE [5]	TYPE [6]	BALL RESET STATE [7]	BALL RESET REL. STATE [8]	BALL RESET REL. MUXMODE [9]	I/O VOLTAGE VALUE [10]	POWER [11]	HYS [12]	BUFFER TYPE [13]	PULL UP/DOWN TYPE [14]	DSIS [15]		
A9	vout1_d21	vout1_d21	No	0	O	PD	PD	15	1.8/3.3	vddshv2	Yes	Dual Voltage LVCMOS	PU/PD			
		emu17		2	O											
		vin4a_d5		3	I										0	
		vin3a_d5		4	I										0	
		obs14		5	O											
		obs30		6	O											
		pr2_edio_data_in5		10	I											0
		pr2_edio_data_out5		11	O											
		pr2_pru0_gpi18		12	I											
		pr2_pru0_gpo18		13	O											
		gpio8_21		14	IO											
		Driver off		15	I											
B9	vout1_d22	vout1_d22	No	0	O	PD	PD	15	1.8/3.3	vddshv2	Yes	Dual Voltage LVCMOS	PU/PD			
		emu18		2	O											
		vin4a_d6		3	I										0	
		vin3a_d6		4	I										0	
		obs15		5	O											
		obs31		6	O											
		pr2_edio_data_in6		10	I											0
		pr2_edio_data_out6		11	O											
		pr2_pru0_gpi19		12	I											
		pr2_pru0_gpo19		13	O											
		gpio8_22		14	IO											
		Driver off		15	I											
A10	vout1_d23	vout1_d23	No	0	O	PD	PD	15	1.8/3.3	vddshv2	Yes	Dual Voltage LVCMOS	PU/PD			
		emu19		2	O											
		vin4a_d7		3	I										0	
		vin3a_d7		4	I										0	
		spi3_cs3		8	IO											1
		pr2_edio_data_in7		10	I											0
		pr2_edio_data_out7		11	O											
		pr2_pru0_gpi20		12	I											
		pr2_pru0_gpo20		13	O											
		gpio8_23		14	IO											
		Driver off		15	I											

Table 4-1. Pin Attributes<sup>(1)</sup> (continued)

BALL NUMBER [1]	BALL NAME [2]	SIGNAL NAME [3]	PN [4]	MUXMODE [5]	TYPE [6]	BALL RESET STATE [7]	BALL RESET REL. STATE [8]	BALL RESET REL. MUXMODE [9]	I/O VOLTAGE VALUE [10]	POWER [11]	HYS [12]	BUFFER TYPE [13]	PULL UP/DOWN TYPE [14]	DSIS [15]
B10	vout1_de	vout1_de	No	0	O	PD	PD	15	1.8/3.3	vddshv2	Yes	Dual Voltage LVCMOS	PU/PD	
		vin4a_de0		3	I									0
		vin3a_de0		4	I									0
		spi3_d1		8	IO									0
		gpio4_20		14	IO									
		Driver off		15	I									
B11	vout1_fld	vout1_fld	No	0	O	PD	PD	15	1.8/3.3	vddshv2	Yes	Dual Voltage LVCMOS	PU/PD	
		vin4a_clk0		3	I									0
		vin3a_clk0		4	I									0
		spi3_cs1		8	IO									1
		gpio4_21		14	IO									
		Driver off		15	I									
C11	vout1_hsync	vout1_hsync	No	0	O	PD	PD	15	1.8/3.3	vddshv2	Yes	Dual Voltage LVCMOS	PU/PD	
		vin4a_hsync0		3	I									0
		vin3a_hsync0		4	I									0
		spi3_d0		8	IO									0
		gpio4_22		14	IO									
		Driver off		15	I									
E11	vout1_vsync	vout1_vsync	No	0	O	PD	PD	15	1.8/3.3	vddshv2	Yes	Dual Voltage LVCMOS	PU/PD	
		vin4a_vsync0		3	I									0
		vin3a_vsync0		4	I									0
		spi3_sclk		8	IO									0
		pr2_pru1_gpi17		12	I									
		pr2_pru1_gpo17		13	O									
		gpio4_23		14	IO									
		Driver off		15	I									

Table 4-1. Pin Attributes<sup>(1)</sup> (continued)

BALL NUMBER [1]	BALL NAME [2]	SIGNAL NAME [3]	PN [4]	MUXMODE [5]	TYPE [6]	BALL RESET STATE [7]	BALL RESET REL. STATE [8]	BALL RESET REL. MUXMODE [9]	I/O VOLTAGE VALUE [10]	POWER [11]	HYS [12]	BUFFER TYPE [13]	PULL UP/DOWN TYPE [14]	DSIS [15]
A1, A14, A2, A23, A28, A6, AA10, AA14, AA15, AA20, AA8, AA9, AB14, AB20, AD1, AD24, AG1, AH1, AH2, AH20, AH28, AH8, B1, D13, D19, E13, E19, F1, F7, G7, G8, G9, H12, J12, J15, J28, K1, K15, K24, K25, K4, K5, L13, L14, M19, N14, N15, N19, N24, N25, P28, R1, R12, R13, R15, R21, T10, T11, T12, T14, T15, T17, T18, T21, U15, U17, U20, U21, V15, V17, W1, W15, W24, W25, W28, AD19, AE19, AD13, AE13, AE10, AA11, AB11, AD10, U14	vss	vss			GND									
AF15	vssa_osc0	vssa_osc0			GND									
AC14	vssa_osc1	vssa_osc1			GND									
AD17	Wakeup0	Wakeup0		0	I	OFF	OFF	15	1.8/3.3	vddshv5	Yes	IHHV1833	PU/PD	
		dcan1_rx		1	I									1
		gpio1_0		14	I									
		Driver off		15	I									
AC17	Wakeup1	Wakeup1		0	I	OFF	OFF	15	1.8/3.3	vddshv5	Yes	IHHV1833	PU/PD	
		dcan2_rx		1	I									1
		gpio1_1		14	I									
		Driver off		15	I									
AB16	Wakeup2	Wakeup2		0	I	OFF	OFF	15	1.8/3.3	vddshv5	Yes	IHHV1833	PU/PD	
		sys_nirq2		1	I									
		gpio1_2		14	I									
		Driver off		15	I									
AC16	Wakeup3	Wakeup3		0	I	OFF	OFF	15	1.8/3.3	vddshv5	Yes	IHHV1833	PU/PD	
		sys_nirq1		1	I									
		gpio1_3		14	I									
		Driver off		15	I									
AE15	xi_osc0	xi_osc0		0	I				1.8	vdda_osc	No	LVC MOS Analog		

Table 4-1. Pin Attributes<sup>(1)</sup> (continued)

BALL NUMBER [1]	BALL NAME [2]	SIGNAL NAME [3]	PN [4]	MUXMODE [5]	TYPE [6]	BALL RESET STATE [7]	BALL RESET REL. STATE [8]	BALL RESET REL. MUXMODE [9]	I/O VOLTAGE VALUE [10]	POWER [11]	HYS [12]	BUFFER TYPE [13]	PULL UP/DOWN TYPE [14]	DSIS [15]				
AC15	xi_osc1	xi_osc1		0	I				1.8	vdda_osc	No	LVC MOS Analog						
AD15	xo_osc0	xo_osc0		0	O				1.8	vdda_osc	No	LVC MOS Analog						
AC13	xo_osc1	xo_osc1		0	A				1.8	vdda_osc	No	LVC MOS Analog						
D18	xref_clk0	xref_clk0		0	I	PD	PD	15	1.8/3.3	vddshv3	Yes	Dual Voltage LVC MOS	PU/PD					
		mcasp2_axr8		1	IO									0				
		mcasp1_axr4		2	IO									0				
		mcasp1_ahclkx		3	O													
		mcasp5_ahclkx		4	O													
		hdq0		8	IO									1				
		clkout2		9	O													
		timer13		10	IO													
		pr2_mii1_col		11	I									0				
		pr2_pru1_gpi5		12	I													
		pr2_pru1_gpo5		13	O													
		gpio6_17		14	IO													
		Driver off		15	I													
		E17	xref_clk1	xref_clk1		0	I	PD	PD	15	1.8/3.3			vddshv3	Yes	Dual Voltage LVC MOS	PU/PD	
				mcasp2_axr9		1	IO											0
mcasp1_axr5				2	IO							0						
mcasp2_ahclkx				3	O													
mcasp6_ahclkx				4	O													
timer14				10	IO													
pr2_mii1_crs				11	I							0						
pr2_pru1_gpi6				12	I													
pr2_pru1_gpo6				13	O													
gpio6_18				14	IO													
Driver off				15	I													



Table 4-1. Pin Attributes<sup>(1)</sup> (continued)

BALL NUMBER [1]	BALL NAME [2]	SIGNAL NAME [3]	PN [4]	MUXMODE [5]	TYPE [6]	BALL RESET STATE [7]	BALL RESET REL. STATE [8]	BALL RESET REL. MUXMODE [9]	I/O VOLTAGE VALUE [10]	POWER [11]	HYS [12]	BUFFER TYPE [13]	PULL UP/DOWN TYPE [14]	DSIS [15]	
B26	xref_clk2	xref_clk2		0	I	PD	PD	15	1.8/3.3	vddshv3	Yes	Dual Voltage LVCMOS	PU/PD		
		mcasp2_axr10		1	IO									0	
		mcasp1_axr6		2	IO									0	
		mcasp3_ahclkx		3	O										
		mcasp7_ahclkx		4	O										
		vout2_clk	No	6	O										
		vin4a_clk0		8	I									0	
		timer15		10	IO										
		gpio6_19		14	IO										
		Driver off		15	I										
C23	xref_clk3	xref_clk3		0	I	PD	PD	15	1.8/3.3	vddshv3	Yes	Dual Voltage LVCMOS	PU/PD		
		mcasp2_axr11		1	IO									0	
		mcasp1_axr7		2	IO									0	
		mcasp4_ahclkx		3	O										
		mcasp8_ahclkx		4	O										
		vout2_de	No	6	O										
		hdq0		7	IO									1	
		vin4a_de0		8	I									0	
		clkout3		9	O										
		timer16		10	IO										
		gpio6_20		14	IO										
				Driver off		15	I								

- (1) NA stands for Not Applicable.
- (2) For more information on recommended operating conditions, see [Section 5.4, Recommended Operating Conditions](#).
- (3) The pullup or pulldown block strength is equal to: minimum = 50  $\mu$ A, typical = 100  $\mu$ A, maximum = 250  $\mu$ A.
- (4) The output impedance settings of this IO cell are programmable; by default, the value is DS[1:0] = 10, this means 40  $\Omega$ . For more information on DS[1:0] register configuration, see the device TRM.
- (5) IO drive strength for usb1\_dp, usb1\_dm, usb2\_dp and usb2\_dm: minimum 18.3 mA, maximum 89 mA (for a power supply vdda33v\_usb1 and vdda33v\_usb2 = 3.46 V).
- (6) Minimum PU = 900  $\Omega$ , maximum PU = 3.090 k $\Omega$  and minimum PD = 14.25 k $\Omega$ , maximum PD = 24.8 k $\Omega$ . For more information, see chapter 7 of the USB2.0 specification, in particular section Signaling / Device Speed Identification.
- (7) In PUX / PDy, x and y = 60  $\mu$ A to 200  $\mu$ A. The output impedance settings (or drive strengths) of this IO are programmable (34  $\Omega$ , 40  $\Omega$ , 48  $\Omega$ , 60  $\Omega$ , 80  $\Omega$ ) depending on the values of the I[2:0] registers.
- (8) This signal is valid only for High-Security devices. For more details, see [Section 5.8, VPP Specification for One-Time Programmable \(OTP\) eFUSES](#). For General Purpose devices do not connect any signal, test point, or board trace to this signal.
- (9) The internal pull resistors for balls K7, M7, J5, K6, J4, J6, H4, H5 are permanently disabled when sysboot15 is set to 1 as described in the *Sysboot Configuration* section in the device TRM. If internal pull-up/down resistors are desired on these balls then sysboot15 should be set to 0. If gpmc boot mode is used with SYSBOOT15=1 (not recommended) then external pull-downs should be implemented to keep the address bus at logic-0 value during boot since the gpmc ms-address bits are high-z during boot.

### 4.3 Signal Descriptions

Many signals are available on multiple pins, according to the software configuration of the pin multiplexing options.

Texas Instruments has developed an application called Pin Mux Utility that helps a system designer select the appropriate pin-multiplexing configuration for their device-based product design. The Pin Mux Utility provides a way to select valid IOSETs of specific peripheral interfaces to ensure the pin multiplexing configuration selected for a design only uses valid IOSETs supported by the device.

1. **SIGNAL NAME:** The name of the signal passing through the pin.

---

#### NOTE

The subsystem multiplexing signals are not described in [Table 4-1](#) and [Table 4-33](#).

---

2. **DESCRIPTION:** Description of the signal

3. **TYPE:** Signal direction and type:

- I = Input
- O = Output
- IO = Input or output
- D = Open Drain
- DS = Differential
- A = Analog
- PWR = Power
- GND = Ground

4. **BALL:** Associated ball(s) bottom

---

#### NOTE

For more information, see the *Control Module / Control Module Register Manual* section in the device TRM.

---

#### 4.3.1 VIP

#### CAUTION

The I/O timings provided in [Section 5.10, Timing Requirements and Switching Characteristics](#) are applicable for all combinations of signals for vin1. However, the timings are valid only for vin2, vin3, and vin4 if signals within a single IOSET are used. The IOSETs are defined in the [Table 5-35](#), [Table 5-36](#) and [Table 5-37](#).

---

#### NOTE

For more information, see the *Video Input Port* section in the device TRM.

---

**Table 4-2. VIP Signal Descriptions**

SIGNAL NAME	DESCRIPTION	TYPE	BALL
<b>Video Input 1</b>			
vin1a_clk0	Video Input 1 Port A Clock input. Input clock for 8-bit 16-bit or 24-bit Port A video capture. Input data is sampled on the CLK0 edge.	I	AG8
vin1a_de0	Video Input 1 Data Enable input	I	AD9

**Table 4-2. VIP Signal Descriptions (continued)**

SIGNAL NAME	DESCRIPTION	TYPE	BALL
vin1a_fld0	Video Input 1 Port A Field ID input	I	AF9
vin1a_hsync0	Video Input 1 Port A Horizontal Sync input	I	AE9
vin1a_vsync0	Video Input 1 Port A Vertical Sync input	I	AF8
vin1a_d0	Video Input 1 Port A Data input	I	AE8
vin1a_d1	Video Input 1 Port A Data input	I	AD8
vin1a_d2	Video Input 1 Port A Data input	I	AG7
vin1a_d3	Video Input 1 Port A Data input	I	AH6
vin1a_d4	Video Input 1 Port A Data input	I	AH3
vin1a_d5	Video Input 1 Port A Data input	I	AH5
vin1a_d6	Video Input 1 Port A Data input	I	AG6
vin1a_d7	Video Input 1 Port A Data input	I	AH4
vin1a_d8	Video Input 1 Port A Data input	I	AG4
vin1a_d9	Video Input 1 Port A Data input	I	AG2
vin1a_d10	Video Input 1 Port A Data input	I	AG3
vin1a_d11	Video Input 1 Port A Data input	I	AG5
vin1a_d12	Video Input 1 Port A Data input	I	AF2
vin1a_d13	Video Input 1 Port A Data input	I	AF6
vin1a_d14	Video Input 1 Port A Data input	I	AF3
vin1a_d15	Video Input 1 Port A Data input	I	AF4
vin1a_d16	Video Input 1 Port A Data input	I	AF1
vin1a_d17	Video Input 1 Port A Data input	I	AE3
vin1a_d18	Video Input 1 Port A Data input	I	AE5
vin1a_d19	Video Input 1 Port A Data input	I	AE1
vin1a_d20	Video Input 1 Port A Data input	I	AE2
vin1a_d21	Video Input 1 Port A Data input	I	AE6
vin1a_d22	Video Input 1 Port A Data input	I	AD2
vin1a_d23	Video Input 1 Port A Data input	I	AD3
vin1b_hsync1	Video Input 1 Port B Horizontal Sync input	I	N6 / AD9
vin1b_vsync1	Video Input 1 Port B Vertical Sync input	I	AF9
vin1b_fld1	Video Input 1 Port B Field ID input	I	AE9
vin1b_de1	Video Input 1 Port B Data Enable input	I	AF8 / M4
vin1b_clk1	Video Input 1 Port B Clock input	I	AH7
vin1b_d0	Video Input 1 Port B Data input	I	AF4 / AD3
vin1b_d1	Video Input 1 Port B Data input	I	AF3 / AD2
vin1b_d2	Video Input 1 Port B Data input	I	AF6 / AE6
vin1b_d3	Video Input 1 Port B Data input	I	AF2 / AE2
vin1b_d4	Video Input 1 Port B Data input	I	AG5 / AE1
vin1b_d5	Video Input 1 Port B Data input	I	AG3 / AE5
vin1b_d6	Video Input 1 Port B Data input	I	AG2 / AE3
vin1b_d7	Video Input 1 Port B Data input	I	AG4 / AF1
<b>Video Input 2</b>			
vin2a_clk0	Video Input 2 Port A Clock input	I	E1 / V1
vin2a_de0	Video Input 2 Port A Data Enable input	I	G2 / V7
vin2a_fld0	Video Input 2 Port A Field ID input	I	H7 / G2 / W2
vin2a_hsync0	Video Input 2 Port A Horizontal Sync input	I	G1 / U7
vin2a_vsync0	Video Input 2 Port A Vertical Sync input	I	G6 / V6
vin2a_d0	Video Input 2 Port A Data input	I	F2 / U4

**Table 4-2. VIP Signal Descriptions (continued)**

SIGNAL NAME	DESCRIPTION	TYPE	BALL
vin2a_d1	Video Input 2 Port A Data input	I	F3 / V2
vin2a_d2	Video Input 2 Port A Data input	I	D1 / Y1
vin2a_d3	Video Input 2 Port A Data input	I	E2 / W9
vin2a_d4	Video Input 2 Port A Data input	I	D2 / V9
vin2a_d5	Video Input 2 Port A Data input	I	F4 / U5
vin2a_d6	Video Input 2 Port A Data input	I	C1 / V5
vin2a_d7	Video Input 2 Port A Data input	I	E4 / V4
vin2a_d8	Video Input 2 Port A Data input	I	F5 / V3
vin2a_d9	Video Input 2 Port A Data input	I	E6 / Y2
vin2a_d10	Video Input 2 Port A Data input	I	D3 / U6
vin2a_d11	Video Input 2 Port A Data input	I	F6 / U3
vin2a_d12	Video Input 2 Port A Data input	I	D5
vin2a_d13	Video Input 2 Port A Data input	I	C2
vin2a_d14	Video Input 2 Port A Data input	I	C3
vin2a_d15	Video Input 2 Port A Data input	I	C4
vin2a_d16	Video Input 2 Port A Data input	I	B2
vin2a_d17	Video Input 2 Port A Data input	I	D6
vin2a_d18	Video Input 2 Port A Data input	I	C5
vin2a_d19	Video Input 2 Port A Data input	I	A3
vin2a_d20	Video Input 2 Port A Data input	I	B3
vin2a_d21	Video Input 2 Port A Data input	I	B4
vin2a_d22	Video Input 2 Port A Data input	I	B5
vin2a_d23	Video Input 2 Port A Data input	I	A4
vin2b_clk1	Video Input 2 Port B Clock input	I	AB5 / H7
vin2b_de1	Video Input 2 Port B Data Enable input	I	AB8 / G2
vin2b fld1	Video Input 2 Port B Field ID input	I	G2
vin2b_hsync1	Video Input 2 Port B Horizontal Sync input	I	AC5 / G1
vin2b_vsync1	Video Input 2 Port B Vertical Sync input	I	AB4 / G6
vin2b_d0	Video Input 2 Port B Data input	I	AD6 / A4
vin2b_d1	Video Input 2 Port B Data input	I	AC8 / B5
vin2b_d2	Video Input 2 Port B Data input	I	AC3 / B4
vin2b_d3	Video Input 2 Port B Data input	I	AC9 / B3
vin2b_d4	Video Input 2 Port B Data input	I	AC6 / A3
vin2b_d5	Video Input 2 Port B Data input	I	AC7 / C5
vin2b_d6	Video Input 2 Port B Data input	I	AC4 / D6
vin2b_d7	Video Input 2 Port B Data input	I	AD4 / B2
<b>Video Input 3</b>			
vin3a_clk0	Video Input 3 Port A Clock input	I	B11 / AH7 / P1
vin3a_de0	Video Input 3 Port A Data Enable input	I	N9 / B3 / B10
vin3a fld0	Video Input 3 Port A Field ID input	I	P9 / B4 / D11
vin3a_hsync0	Video Input 3 Port A Horizontal Sync input	I	N7 / B5 / C11
vin3a_vsync0	Video Input 3 Port A Vertical Sync input	I	R4 / A4 / E11
vin3a_d0	Video Input 3 Port A Data input	I	M6 / AF1 / B7
vin3a_d1	Video Input 3 Port A Data input	I	M2 / AE3 / B8
vin3a_d2	Video Input 3 Port A Data input	I	L5 / AE5 / A7
vin3a_d3	Video Input 3 Port A Data input	I	M1 / AE1 / A8
vin3a_d4	Video Input 3 Port A Data input	I	L6 / AE2 / C9

**Table 4-2. VIP Signal Descriptions (continued)**

SIGNAL NAME	DESCRIPTION	TYPE	BALL
vin3a_d5	Video Input 3 Port A Data input	I	L4 / AE6 / A9
vin3a_d6	Video Input 3 Port A Data input	I	L3 / AD2 / B9
vin3a_d7	Video Input 3 Port A Data input	I	L2 / AD3 / A10
vin3a_d8	Video Input 3 Port A Data input	I	L1 / B2 / E8
vin3a_d9	Video Input 3 Port A Data input	I	K2 / D6 / D9
vin3a_d10	Video Input 3 Port A Data input	I	J1 / C5 / D7
vin3a_d11	Video Input 3 Port A Data input	I	J2 / A3 / D8
vin3a_d12	Video Input 3 Port A Data input	I	H1 / B3 / A5
vin3a_d13	Video Input 3 Port A Data input	I	J3 / B4 / C6
vin3a_d14	Video Input 3 Port A Data input	I	H2 / B5 / C8
vin3a_d15	Video Input 3 Port A Data input	I	H3 / A4 / C7
vin3a_d16	Video Input 3 Port A Data input	I	R6 / F11
vin3a_d17	Video Input 3 Port A Data input	I	T9 / G10
vin3a_d18	Video Input 3 Port A Data input	I	T6 / F10
vin3a_d19	Video Input 3 Port A Data input	I	T7 / G11
vin3a_d20	Video Input 3 Port A Data input	I	P6 / E9
vin3a_d21	Video Input 3 Port A Data input	I	R9 / F9
vin3a_d22	Video Input 3 Port A Data input	I	R5 / F8
vin3a_d23	Video Input 3 Port A Data input	I	P5 / E7
vin3b_clk1	Video Input 3 Port B Clock input	I	P7 / M4
vin3b_de1	Video Input 3 Port B Data Enable input	I	N6
vin3b fld1	Video Input 3 Port A Field ID input	I	M4
vin3b_hsync1	Video Input 3 Port A Horizontal Sync input	I	H5
vin3b_vsync1	Video Input 3 Port A Vertical Sync input	I	H6
vin3b_d0	Video Input 3 Port B Data input	I	K7
vin3b_d1	Video Input 3 Port B Data input	I	M7
vin3b_d2	Video Input 3 Port B Data input	I	J5
vin3b_d3	Video Input 3 Port B Data input	I	K6
vin3b_d4	Video Input 3 Port B Data input	I	J7
vin3b_d5	Video Input 3 Port B Data input	I	J4
vin3b_d6	Video Input 3 Port B Data input	I	J6
vin3b_d7	Video Input 3 Port B Data input	I	H4
<b>Video Input 4</b>			
vin4a_clk0	Video Input 4 Port A Clock input	I	P4 / B26 / B11
vin4a_de0	Video Input 4 Port A Data Enable input	I	H6 / C23 / B10 / P7
vin4a fld0	Video Input 4 Port A Field ID input	I	J7 / F21 / P9 / D11
vin4a_hsync0	Video Input 4 Port A Horizontal Sync input	I	R3 / E21 / C11 / P7
vin4a_vsync0	Video Input 4 Port A Vertical Sync input	I	T2 / F20 / E11 / N1
vin4a_d0	Video Input 4 Port A Data input	I	R6 / B7 / B14
vin4a_d1	Video Input 4 Port A Data input	I	T9 / B8 / J14
vin4a_d2	Video Input 4 Port A Data input	I	T6 / A7 / G13
vin4a_d3	Video Input 4 Port A Data input	I	T7 / A8 / J11
vin4a_d4	Video Input 4 Port A Data input	I	P6 / C9 / E12
vin4a_d5	Video Input 4 Port A Data input	I	R9 / A9 / F13
vin4a_d6	Video Input 4 Port A Data input	I	R5 / B9 / C12
vin4a_d7	Video Input 4 Port A Data input	I	P5 / A10 / D12
vin4a_d8	Video Input 4 Port A Data input	I	E8 / U2 / E15

**Table 4-2. VIP Signal Descriptions (continued)**

SIGNAL NAME	DESCRIPTION	TYPE	BALL
vin4a_d9	Video Input 4 Port A Data input	I	D9 / U1 / A20
vin4a_d10	Video Input 4 Port A Data input	I	D7 / P3 / B15
vin4a_d11	Video Input 4 Port A Data input	I	D8 / R2 / A15
vin4a_d12	Video Input 4 Port A Data input	I	A5 / K7 / D15
vin4a_d13	Video Input 4 Port A Data input	I	C6 / M7 / B16
vin4a_d14	Video Input 4 Port A Data input	I	C8 / J5 / B17
vin4a_d15	Video Input 4 Port A Data input	I	C7 / K6 / A17
vin4a_d16	Video Input 4 Port A Data input	I	C18 / F11
vin4a_d17	Video Input 4 Port A Data input	I	A21 / G10
vin4a_d18	Video Input 4 Port A Data input	I	G16 / F10
vin4a_d19	Video Input 4 Port A Data input	I	D17 / G11
vin4a_d20	Video Input 4 Port A Data input	I	AA3 / E9
vin4a_d21	Video Input 4 Port A Data input	I	AB9 / F9
vin4a_d22	Video Input 4 Port A Data input	I	AB3 / F8
vin4a_d23	Video Input 4 Port A Data input	I	AA4 / E7
vin4b_clk1	Video Input 4 Port B Clock input	I	N9 / V1
vin4b_de1	Video Input 4 Port B Data Enable input	I	P9 / V7
vin4b fld1	Video Input 4 Port B Field ID input	I	P4 / W2
vin4b_hsync1	Video Input 4 Port B Horizontal Sync input	I	N7 / U7
vin4b_vsync1	Video Input 4 Port B Vertical Sync input	I	R4 / V6
vin4b_d0	Video Input 4 Port B Data input	I	R6 / U4
vin4b_d1	Video Input 4 Port B Data input	I	T9 / V2
vin4b_d2	Video Input 4 Port B Data input	I	T6 / Y1
vin4b_d3	Video Input 4 Port B Data input	I	T7 / W9
vin4b_d4	Video Input 4 Port B Data input	I	P6 / V9
vin4b_d5	Video Input 4 Port B Data input	I	R9 / U5
vin4b_d6	Video Input 4 Port B Data input	I	R5 / V5
vin4b_d7	Video Input 4 Port B Data input	I	P5 / V4

### 4.3.2 DSS

#### CAUTION

The I/O timings provided in [Section 5.10, Timing Requirements and Switching Characteristics](#) are valid only if signals within a single IOSET are used. The IOSETs are defined in [Table 5-49](#) and [Table 5-50](#).

**Table 4-3. DSS Signal Descriptions**

SIGNAL NAME	DESCRIPTION	TYPE	BALL
<b>DPI Video Output 1</b>			
vout1_clk	Video Output 1 Clock output	O	D11
vout1_de	Video Output 1 Data Enable output	O	B10
vout1 fld	Video Output 1 Field ID output. This signal is not used for embedded sync modes.	O	B11
vout1_hsync	Video Output 1 Horizontal Sync output. This signal is not used for embedded sync modes.	O	C11
vout1_vsync	Video Output 1 Vertical Sync output. This signal is not used for embedded sync modes.	O	E11
vout1_d0	Video Output 1 Data output	O	F11

**Table 4-3. DSS Signal Descriptions (continued)**

SIGNAL NAME	DESCRIPTION	TYPE	BALL
vout1_d1	Video Output 1 Data output	O	G10
vout1_d2	Video Output 1 Data output	O	F10
vout1_d3	Video Output 1 Data output	O	G11
vout1_d4	Video Output 1 Data output	O	E9
vout1_d5	Video Output 1 Data output	O	F9
vout1_d6	Video Output 1 Data output	O	F8
vout1_d7	Video Output 1 Data output	O	E7
vout1_d8	Video Output 1 Data output	O	E8
vout1_d9	Video Output 1 Data output	O	D9
vout1_d10	Video Output 1 Data output	O	D7
vout1_d11	Video Output 1 Data output	O	D8
vout1_d12	Video Output 1 Data output	O	A5
vout1_d13	Video Output 1 Data output	O	C6
vout1_d14	Video Output 1 Data output	O	C8
vout1_d15	Video Output 1 Data output	O	C7
vout1_d16	Video Output 1 Data output	O	B7
vout1_d17	Video Output 1 Data output	O	B8
vout1_d18	Video Output 1 Data output	O	A7
vout1_d19	Video Output 1 Data output	O	A8
vout1_d20	Video Output 1 Data output	O	C9
vout1_d21	Video Output 1 Data output	O	A9
vout1_d22	Video Output 1 Data output	O	B9
vout1_d23	Video Output 1 Data output	O	A10
<b>DPI Video Output 2</b>			
vout2_clk	Video Output 2 Clock output	O	H7/ B26
vout2_de	Video Output 2 Data Enable output	O	G2 / C23
vout2 fld	Video Output 2 Field ID output. This signal is not used for embedded sync modes.	O	E1 / F21
vout2_hsync	Video Output 2 Horizontal Sync output. This signal is not used for embedded sync modes.	O	G1 / E21
vout2_vsync	Video Output 2 Vertical Sync output. This signal is not used for embedded sync modes.	O	G6 / F20
vout2_d0	Video Output 2 Data output	O	A4 / B14
vout2_d1	Video Output 2 Data output	O	B5 / J14
vout2_d2	Video Output 2 Data output	O	B4 / G13
vout2_d3	Video Output 2 Data output	O	B3 / J11
vout2_d4	Video Output 2 Data output	O	A3 / E12
vout2_d5	Video Output 2 Data output	O	C5 / F13
vout2_d6	Video Output 2 Data output	O	D6 / C12
vout2_d7	Video Output 2 Data output	O	B2 / D12
vout2_d8	Video Output 2 Data output	O	C4 / E15
vout2_d9	Video Output 2 Data output	O	C3 / A20
vout2_d10	Video Output 2 Data output	O	C2 / B15
vout2_d11	Video Output 2 Data output	O	D5 / A15
vout2_d12	Video Output 2 Data output	O	F6 / D15
vout2_d13	Video Output 2 Data output	O	D3 / B16
vout2_d14	Video Output 2 Data output	O	E6 / B17
vout2_d15	Video Output 2 Data output	O	F5 / A17
vout2_d16	Video Output 2 Data output	O	E4 / C18
vout2_d17	Video Output 2 Data output	O	C1 / A21

**Table 4-3. DSS Signal Descriptions (continued)**

SIGNAL NAME	DESCRIPTION	TYPE	BALL
vout2_d18	Video Output 2 Data output	O	F4 / G16
vout2_d19	Video Output 2 Data output	O	D2 / D17
vout2_d20	Video Output 2 Data output	O	E2 / AA3
vout2_d21	Video Output 2 Data output	O	D1 / AB9
vout2_d22	Video Output 2 Data output	O	F3 / AB3
vout2_d23	Video Output 2 Data output	O	F2 / AA4
<b>DPI Video Output 3</b>			
vout3_clk	Video Output 3 Clock output	O	P1 / AF9
vout3_de	Video Output 3 Data Enable output	O	N9 / AD9
vout3_fid	Video Output 3 Field ID output. This signal is not used for embedded sync modes.	O	P9 / AG8
vout3_hsync	Video Output 3 Horizontal Sync output. This signal is not used for embedded sync modes.	O	N7 / AE9
vout3_vsync	Video Output 3 Vertical Sync output. This signal is not used for embedded sync modes.	O	R4 / AF8
vout3_d0	Video Output 3 Data output	O	M6 / AH4 / AD3
vout3_d1	Video Output 3 Data output	O	M2 / AG6 / AD2
vout3_d2	Video Output 3 Data output	O	L5 / AH5 / AE6
vout3_d3	Video Output 3 Data output	O	M1 / AH3 / AE2
vout3_d4	Video Output 3 Data output	O	L6 / AH6 / AE1
vout3_d5	Video Output 3 Data output	O	L4 / AG7 / AE5
vout3_d6	Video Output 3 Data output	O	L3 / AD8 / AE3
vout3_d7	Video Output 3 Data output	O	L2 / AE8 / AF1
vout3_d8	Video Output 3 Data output	O	L1 / AF4
vout3_d9	Video Output 3 Data output	O	K2 / AF3
vout3_d10	Video Output 3 Data output	O	J1 / AF6
vout3_d11	Video Output 3 Data output	O	J2 / AF2
vout3_d12	Video Output 3 Data output	O	H1 / AG5
vout3_d13	Video Output 3 Data output	O	J3 / AG3
vout3_d14	Video Output 3 Data output	O	H2 / AG2
vout3_d15	Video Output 3 Data output	O	H3 / AG4
vout3_d16	Video Output 3 Data output	O	R6 / AG8 / AH4
vout3_d17	Video Output 3 Data output	O	T9 / AD9 / AG6
vout3_d18	Video Output 3 Data output	O	T6 / AH5
vout3_d19	Video Output 3 Data output	O	T7 / AH3
vout3_d20	Video Output 3 Data output	O	P6 / AH6
vout3_d21	Video Output 3 Data output	O	R9 / AG7
vout3_d22	Video Output 3 Data output	O	R5 / AD8
vout3_d23	Video Output 3 Data output	O	P5 / AE8

### 4.3.3 HDMI

#### NOTE

For more information, see the *Display Subsystem / Display Subsystem Overview* in the device TRM.

**Table 4-4. HDMI Signal Descriptions**

SIGNAL NAME	DESCRIPTION	TYPE	BALL
hdmi1_cec	HDMI consumer electronic control	IOD	B20/ G19



**Table 4-4. HDMI Signal Descriptions (continued)**

SIGNAL NAME	DESCRIPTION	TYPE	BALL
hdmi1_hpd	HDMI display hot plug detect	I	B21/ G20
hdmi1_ddc_scl	HDMI display data channel clock	IOD	C25
hdmi1_ddc_sda	HDMI display data channel data	IOD	F17
hdmi1_clockx	HDMI clock differential positive or negative	ODS	AG16
hdmi1_clocky	HDMI clock differential positive or negative	ODS	AH16
hdmi1_data2x	HDMI data 2 differential positive or negative	ODS	AG19
hdmi1_data2y	HDMI data 2 differential positive or negative	ODS	AH19
hdmi1_data1x	HDMI data 1 differential positive or negative	ODS	AG18
hdmi1_data1y	HDMI data 1 differential positive or negative	ODS	AH18
hdmi1_data0x	HDMI data 0 differential positive or negative	ODS	AG17
hdmi1_data0y	HDMI data 0 differential positive or negative	ODS	AH17

#### 4.3.4 EMIF

---

##### NOTE

For more information, see the *Memory Subsystem / EMIF Controller* section in the device TRM.

---

##### NOTE

The index numbers 1 and 2 which are part of the EMIF1 and EMIF2 signal prefixes (ddr1\_\* and ddr2\_\*) listed in [Table 4-5, EMIF Signal Descriptions](#), not to be confused with DDR1 and DDR2 types of SDRAM memories.

---

**Table 4-5. EMIF Signal Descriptions**

SIGNAL NAME	DESCRIPTION	TYPE	BALL
<b>EMIF Channel 1</b>			
ddr1_csn0	EMIF1 Chip Select 0	O	AH23
ddr1_cke	EMIF1 Clock Enable	O	AG22
ddr1_ck	EMIF1 Clock	O	AG24
ddr1_nck	EMIF1 Negative Clock	O	AH24
ddr1_odt0	EMIF1 On-Die Termination for Chip Select 0	O	AE20
ddr1_casn	EMIF1 Column Address Strobe	O	AC18
ddr1_rasn	EMIF1 Row Address Strobe	O	AF20
ddr1_wen	EMIF1 Write Enable	O	AH21
ddr1_rst	EMIF1 Reset output (DDR3-SDRAM only)	O	AG21
ddr1_ba0	EMIF1 Bank Address	O	AF17
ddr1_ba1	EMIF1 Bank Address	O	AE18
ddr1_ba2	EMIF1 Bank Address	O	AB18
ddr1_a0	EMIF1 Address Bus	O	AD20
ddr1_a1	EMIF1 Address Bus	O	AC19
ddr1_a2	EMIF1 Address Bus	O	AC20
ddr1_a3	EMIF1 Address Bus	O	AB19
ddr1_a4	EMIF1 Address Bus	O	AF21
ddr1_a5	EMIF1 Address Bus	O	AH22
ddr1_a6	EMIF1 Address Bus	O	AG23
ddr1_a7	EMIF1 Address Bus	O	AE21

Table 4-5. EMIF Signal Descriptions (continued)

SIGNAL NAME	DESCRIPTION	TYPE	BALL
ddr1_a8	EMIF1 Address Bus	O	AF22
ddr1_a9	EMIF1 Address Bus	O	AE22
ddr1_a10	EMIF1 Address Bus	O	AD21
ddr1_a11	EMIF1 Address Bus	O	AD22
ddr1_a12	EMIF1 Address Bus	O	AC21
ddr1_a13	EMIF1 Address Bus	O	AF18
ddr1_a14	EMIF1 Address Bus	O	AE17
ddr1_a15	EMIF1 Address Bus	O	AD18
ddr1_d0	EMIF1 Data Bus	IO	AF25
ddr1_d1	EMIF1 Data Bus	IO	AF26
ddr1_d2	EMIF1 Data Bus	IO	AG26
ddr1_d3	EMIF1 Data Bus	IO	AH26
ddr1_d4	EMIF1 Data Bus	IO	AF24
ddr1_d5	EMIF1 Data Bus	IO	AE24
ddr1_d6	EMIF1 Data Bus	IO	AF23
ddr1_d7	EMIF1 Data Bus	IO	AE23
ddr1_d8	EMIF1 Data Bus	IO	AC23
ddr1_d9	EMIF1 Data Bus	IO	AF27
ddr1_d10	EMIF1 Data Bus	IO	AG27
ddr1_d11	EMIF1 Data Bus	IO	AF28
ddr1_d12	EMIF1 Data Bus	IO	AE26
ddr1_d13	EMIF1 Data Bus	IO	AC25
ddr1_d14	EMIF1 Data Bus	IO	AC24
ddr1_d15	EMIF1 Data Bus	IO	AD25
ddr1_d16	EMIF1 Data Bus	IO	V20
ddr1_d17	EMIF1 Data Bus	IO	W20
ddr1_d18	EMIF1 Data Bus	IO	AB28
ddr1_d19	EMIF1 Data Bus	IO	AC28
ddr1_d20	EMIF1 Data Bus	IO	AC27
ddr1_d21	EMIF1 Data Bus	IO	Y19
ddr1_d22	EMIF1 Data Bus	IO	AB27
ddr1_d23	EMIF1 Data Bus	IO	Y20
ddr1_d24	EMIF1 Data Bus	IO	AA23
ddr1_d25	EMIF1 Data Bus	IO	Y22
ddr1_d26	EMIF1 Data Bus	IO	Y23
ddr1_d27	EMIF1 Data Bus	IO	AA24
ddr1_d28	EMIF1 Data Bus	IO	Y24
ddr1_d29	EMIF1 Data Bus	IO	AA26
ddr1_d30	EMIF1 Data Bus	IO	AA25
ddr1_d31	EMIF1 Data Bus	IO	AA28
ddr1_ecc_d0	EMIF1 ECC Data Bus	IO	W22
ddr1_ecc_d1	EMIF1 ECC Data Bus	IO	V23
ddr1_ecc_d2	EMIF1 ECC Data Bus	IO	W19
ddr1_ecc_d3	EMIF1 ECC Data Bus	IO	W23
ddr1_ecc_d4	EMIF1 ECC Data Bus	IO	Y25
ddr1_ecc_d5	EMIF1 ECC Data Bus	IO	V24
ddr1_ecc_d6	EMIF1 ECC Data Bus	IO	V25

**Table 4-5. EMIF Signal Descriptions (continued)**

SIGNAL NAME	DESCRIPTION	TYPE	BALL
ddr1_ecc_d7	EMIF1 ECC Data Bus	IO	Y26
ddr1_dqm0	EMIF1 Data Mask	O	AD23
ddr1_dqm1	EMIF1 Data Mask	O	AB23
ddr1_dqm2	EMIF1 Data Mask	O	AC26
ddr1_dqm3	EMIF1 Data Mask	O	AA27
ddr1_dqm_ecc	EMIF1 ECC Data Mask	O	V26
ddr1_dqs0	Data strobe 0 input/output for byte 0 of the 32-bit data bus. This signal is output to the EMIF1 memory when writing and input when reading.	IO	AH25
ddr1_dqsn0	Data strobe 0 invert	IO	AG25
ddr1_dqs1	Data strobe 1 input/output for byte 1 of the 32-bit data bus. This signal is output to the EMIF1 memory when writing and input when reading.	IO	AE27
ddr1_dqsn1	Data strobe 1 invert	IO	AE28
ddr1_dqs2	Data strobe 2 input/output for byte 2 of the 32-bit data bus. This signal is output to the EMIF1 memory when writing and input when reading.	IO	AD27
ddr1_dqsn2	Data strobe 2 invert	IO	AD28
ddr1_dqs3	Data strobe 3 input/output for byte 3 of the 32-bit data bus. This signal is output to the EMIF1 memory when writing and input when reading.	IO	Y28
ddr1_dqsn3	Data strobe 3 invert	IO	Y27
ddr1_dqs_ecc	EMIF1 ECC Data strobe input/output. This signal is output to the EMIF1 memory when writing and input when reading.	IO	V27
ddr1_dqsn_ecc	EMIF1 ECC Complementary Data Strobe	IO	V28
ddr1_vref0	Reference Power Supply EMIF1	A	Y18
<b>EMIF Channel 2</b>			
ddr2_csn0	EMIF2 Chip Select 0	O	P24
ddr2_cke	EMIF2 Clock Enable	O	U24
ddr2_ck	EMIF2 Clock	O	T28
ddr2_nck	EMIF2 Negative Clock	O	T27
ddr2_odt0	EMIF2 On-Die Termination for Chip Select 0	O	R23
ddr2_casn	EMIF2 Column Address Strobe	O	U28
ddr2_rasn	EMIF2 Row Address Strobe	O	T23
ddr2_wen	EMIF2 Write Enable	O	U25
ddr2_rst	EMIF2 Reset output (DDR3-SDRAM only)	O	R24
ddr2_ba0	EMIF2 Bank Address	O	U23
ddr2_ba1	EMIF2 Bank Address	O	U27
ddr2_ba2	EMIF2 Bank Address	O	U26
ddr2_a0	EMIF2 Address Bus	O	R25
ddr2_a1	EMIF2 Address Bus	O	R26
ddr2_a2	EMIF2 Address Bus	O	R28
ddr2_a3	EMIF2 Address Bus	O	R27
ddr2_a4	EMIF2 Address Bus	O	P23
ddr2_a5	EMIF2 Address Bus	O	P22
ddr2_a6	EMIF2 Address Bus	O	P25
ddr2_a7	EMIF2 Address Bus	O	N20
ddr2_a8	EMIF2 Address Bus	O	P27
ddr2_a9	EMIF2 Address Bus	O	N27
ddr2_a10	EMIF2 Address Bus	O	N23
ddr2_a11	EMIF2 Address Bus	O	P26
ddr2_a12	EMIF2 Address Bus	O	N28
ddr2_a13	EMIF2 Address Bus	O	T22

**Table 4-5. EMIF Signal Descriptions (continued)**

SIGNAL NAME	DESCRIPTION	TYPE	BALL
ddr2_a14	EMIF2 Address Bus	O	R22
ddr2_a15	EMIF2 Address Bus	O	U22
ddr2_d0	EMIF2 Data Bus	IO	E26
ddr2_d1	EMIF2 Data Bus	IO	G25
ddr2_d2	EMIF2 Data Bus	IO	F25
ddr2_d3	EMIF2 Data Bus	IO	F24
ddr2_d4	EMIF2 Data Bus	IO	F26
ddr2_d5	EMIF2 Data Bus	IO	F27
ddr2_d6	EMIF2 Data Bus	IO	E27
ddr2_d7	EMIF2 Data Bus	IO	E28
ddr2_d8	EMIF2 Data Bus	IO	H23
ddr2_d9	EMIF2 Data Bus	IO	H25
ddr2_d10	EMIF2 Data Bus	IO	H24
ddr2_d11	EMIF2 Data Bus	IO	H26
ddr2_d12	EMIF2 Data Bus	IO	G26
ddr2_d13	EMIF2 Data Bus	IO	J25
ddr2_d14	EMIF2 Data Bus	IO	J26
ddr2_d15	EMIF2 Data Bus	IO	J24
ddr2_d16	EMIF2 Data Bus	IO	L22
ddr2_d17	EMIF2 Data Bus	IO	K20
ddr2_d18	EMIF2 Data Bus	IO	K21
ddr2_d19	EMIF2 Data Bus	IO	L23
ddr2_d20	EMIF2 Data Bus	IO	L24
ddr2_d21	EMIF2 Data Bus	IO	J23
ddr2_d22	EMIF2 Data Bus	IO	K22
ddr2_d23	EMIF2 Data Bus	IO	J20
ddr2_d24	EMIF2 Data Bus	IO	L27
ddr2_d25	EMIF2 Data Bus	IO	L26
ddr2_d26	EMIF2 Data Bus	IO	L25
ddr2_d27	EMIF2 Data Bus	IO	L28
ddr2_d28	EMIF2 Data Bus	IO	M23
ddr2_d29	EMIF2 Data Bus	IO	M24
ddr2_d30	EMIF2 Data Bus	IO	M25
ddr2_d31	EMIF2 Data Bus	IO	M26
ddr2_dqm0	EMIF2 Data Mask	O	F28
ddr2_dqm1	EMIF2 Data Mask	O	G24
ddr2_dqm2	EMIF2 Data Mask	O	K23
ddr2_dqm3	EMIF2 Data Mask	O	M22
ddr2_dqs0	Data strobe 0 input/output for byte 0 of the 32-bit data bus. This signal is output to the EMIF2 memory when writing and input when reading.	IO	G28
ddr2_dqsn0	Data strobe 0 invert	IO	G27
ddr2_dqs1	Data strobe 1 input/output for byte 1 of the 32-bit data bus. This signal is output to the EMIF2 memory when writing and input when reading.	IO	H27
ddr2_dqsn1	Data strobe 1 invert	IO	H28
ddr2_dqs2	Data strobe 2 input/output for byte 2 of the 32-bit data bus. This signal is output to the EMIF2 memory when writing and input when reading.	IO	K27
ddr2_dqsn2	Data strobe 2 invert	IO	K28

**Table 4-5. EMIF Signal Descriptions (continued)**

SIGNAL NAME	DESCRIPTION	TYPE	BALL
ddr2_dqs3	Data strobe 3 input/output for byte 3 of the 32-bit data bus. This signal is output to the EMIF2 memory when writing and input when reading.	IO	M28
ddr2_dqsn3	Data strobe 3 invert	IO	M27
ddr2_vref0	Reference Power Supply EMIF2	A	N22

### 4.3.5 GPMC

#### NOTE

For more information, see the *Memory Subsystem / General-Purpose Memory Controller* section in the device TRM.

**Table 4-6. GPMC Signal Descriptions**

SIGNAL NAME	DESCRIPTION	TYPE	BALL
gpmc_ad0	GPMC Data 0 in A/D nonmultiplexed mode and additionally Address 1 in A/D multiplexed mode	IO	M6
gpmc_ad1	GPMC Data 1 in A/D nonmultiplexed mode and additionally Address 2 in A/D multiplexed mode	IO	M2
gpmc_ad2	GPMC Data 2 in A/D nonmultiplexed mode and additionally Address 3 in A/D multiplexed mode	IO	L5
gpmc_ad3	GPMC Data 3 in A/D nonmultiplexed mode and additionally Address 4 in A/D multiplexed mode	IO	M1
gpmc_ad4	GPMC Data 4 in A/D nonmultiplexed mode and additionally Address 5 in A/D multiplexed mode	IO	L6
gpmc_ad5	GPMC Data 5 in A/D nonmultiplexed mode and additionally Address 6 in A/D multiplexed mode	IO	L4
gpmc_ad6	GPMC Data 6 in A/D nonmultiplexed mode and additionally Address 7 in A/D multiplexed mode	IO	L3
gpmc_ad7	GPMC Data 7 in A/D nonmultiplexed mode and additionally Address 8 in A/D multiplexed mode	IO	L2
gpmc_ad8	GPMC Data 8 in A/D nonmultiplexed mode and additionally Address 9 in A/D multiplexed mode	IO	L1
gpmc_ad9	GPMC Data 9 in A/D nonmultiplexed mode and additionally Address 10 in A/D multiplexed mode	IO	K2
gpmc_ad10	GPMC Data 10 in A/D nonmultiplexed mode and additionally Address 11 in A/D multiplexed mode	IO	J1
gpmc_ad11	GPMC Data 11 in A/D nonmultiplexed mode and additionally Address 12 in A/D multiplexed mode	IO	J2
gpmc_ad12	GPMC Data 12 in A/D nonmultiplexed mode and additionally Address 13 in A/D multiplexed mode	IO	H1
gpmc_ad13	GPMC Data 13 in A/D nonmultiplexed mode and additionally Address 14 in A/D multiplexed mode	IO	J3
gpmc_ad14	GPMC Data 14 in A/D nonmultiplexed mode and additionally Address 15 in A/D multiplexed mode	IO	H2
gpmc_ad15	GPMC Data 15 in A/D nonmultiplexed mode and additionally Address 16 in A/D multiplexed mode	IO	H3
gpmc_a0	GPMC Address 0. Only used to effectively address 8-bit data nonmultiplexed memories	O	R6 / P4
gpmc_a1	GPMC address 1 in A/D nonmultiplexed mode and Address 17 in A/D multiplexed mode	O	T9 / P1
gpmc_a2	GPMC address 2 in A/D nonmultiplexed mode and Address 18 in A/D multiplexed mode	O	T6 / N1
gpmc_a3	GPMC address 3 in A/D nonmultiplexed mode and Address 19 in A/D multiplexed mode	O	T7 / M4

**Table 4-6. GPMC Signal Descriptions (continued)**

SIGNAL NAME	DESCRIPTION	TYPE	BALL
gpmc_a4	GPMC address 4 in A/D nonmultiplexed mode and Address 20 in A/D multiplexed mode	O	P6
gpmc_a5	GPMC address 5 in A/D nonmultiplexed mode and Address 21 in A/D multiplexed mode	O	R9
gpmc_a6	GPMC address 6 in A/D nonmultiplexed mode and Address 22 in A/D multiplexed mode	O	R5
gpmc_a7	GPMC address 7 in A/D nonmultiplexed mode and Address 23 in A/D multiplexed mode	O	P5
gpmc_a8	GPMC address 8 in A/D nonmultiplexed mode and Address 24 in A/D multiplexed mode	O	N7
gpmc_a9	GPMC address 9 in A/D nonmultiplexed mode and Address 25 in A/D multiplexed mode	O	R4
gpmc_a10	GPMC address 10 in A/D nonmultiplexed mode and Address 26 in A/D multiplexed mode	O	N9
gpmc_a11	GPMC address 11 in A/D nonmultiplexed mode and unused in A/D multiplexed mode	O	P9
gpmc_a12	GPMC address 12 in A/D nonmultiplexed mode and unused in A/D multiplexed mode	O	P4
gpmc_a13	GPMC address 13 in A/D nonmultiplexed mode and unused in A/D multiplexed mode	O	R3 / K7 / P2
gpmc_a14	GPMC address 14 in A/D nonmultiplexed mode and unused in A/D multiplexed mode	O	T2 / M7 / P1
gpmc_a15	GPMC address 15 in A/D nonmultiplexed mode and unused in A/D multiplexed mode	O	U2 / J5 / N2
gpmc_a16	GPMC address 16 in A/D nonmultiplexed mode and unused in A/D multiplexed mode	O	U1 / K6 / R6
gpmc_a17	GPMC address 17 in A/D nonmultiplexed mode and unused in A/D multiplexed mode	O	P3 / J7 / E1
gpmc_a18	GPMC address 18 in A/D nonmultiplexed mode and unused in A/D multiplexed mode	O	R2 / J4 / H7
gpmc_a19	GPMC address 19 in A/D nonmultiplexed mode and unused in A/D multiplexed mode	O	K7 <sup>(3)</sup> / J6 / N1
gpmc_a20	GPMC address 20 in A/D nonmultiplexed mode and unused in A/D multiplexed mode	O	M7 <sup>(3)</sup> / H4 / P7
gpmc_a21	GPMC address 21 in A/D nonmultiplexed mode and unused in A/D multiplexed mode	O	J5 <sup>(3)</sup> / H5 / N6
gpmc_a22	GPMC address 22 in A/D nonmultiplexed mode and unused in A/D multiplexed mode	O	K6 <sup>(3)</sup> / H6 / M4
gpmc_a23	GPMC address 23 in A/D nonmultiplexed mode and unused in A/D multiplexed mode	O	J7 / AG5 / N1 / P2 / F6
gpmc_a24	GPMC address 24 in A/D nonmultiplexed mode and unused in A/D multiplexed mode	O	J4 <sup>(3)</sup> / AF2 / P1 / D3
gpmc_a25	GPMC address 25 in A/D nonmultiplexed mode and unused in A/D multiplexed mode	O	J6 <sup>(3)</sup> / AF6 / N2 / E6
gpmc_a26	GPMC address 26 in A/D nonmultiplexed mode and unused in A/D multiplexed mode	O	H4 <sup>(3)</sup> / AF3 / R6 / F5
gpmc_a27	GPMC address 27 in A/D nonmultiplexed mode and Address 27 in A/D multiplexed mode	O	H5 <sup>(3)</sup> / AF4 / E1 / H7 / G1
gpmc_cs0	GPMC Chip Select 0 (active low)	O	T1
gpmc_cs1	GPMC Chip Select 1 (active low)	O	H6
gpmc_cs2	GPMC Chip Select 2 (active low)	O	P2
gpmc_cs3	GPMC Chip Select 3 (active low)	O	P1
gpmc_cs4	GPMC Chip Select 4 (active low)	O	N6
gpmc_cs5	GPMC Chip Select 5 (active low)	O	M4
gpmc_cs6	GPMC Chip Select 6 (active low)	O	N1

**Table 4-6. GPMC Signal Descriptions (continued)**

SIGNAL NAME	DESCRIPTION	TYPE	BALL
gpmc_cs7	GPMC Chip Select 7 (active low)	O	P7
gpmc_clk <sup>(1)(2)</sup>	GPMC Clock output	IO	P7
gpmc_advn_ale	GPMC address valid active low or address latch enable	O	N1
gpmc_oen_ren	GPMC output enable active low or read enable	O	M5
gpmc_wen	GPMC write enable active low	O	M3
gpmc_ben0	GPMC lower-byte enable active low	O	N6
gpmc_ben1	GPMC upper-byte enable active low	O	M4
gpmc_wait0	GPMC external indication of wait 0	I	N2
gpmc_wait1	GPMC external indication of wait 1	I	P7 / N1

- (1) This clock signal is implemented as 'pad loopback' inside the device - the output signal is looped back through the input buffer to serve as the internal reference signal. Series termination is recommended (as close to device pin as possible) to improve signal integrity of the clock input. Any nonmonotonicity in voltage that occurs at the pad loopback clock pin between  $V_{IH}$  and  $V_{IL}$  must be less than  $V_{HYS}$ .
- (2) The gpio6\_16.clkout1 signal can be used as an "always-on" alternative to gpmc\_clk provided that the external device can support the associated timing. See [Table 5-57, GPMC/NOR Flash Interface Switching Characteristics - Synchronous Mode - Default](#) and [Table 5-59, GPMC/NOR Flash Interface Switching Characteristics - Synchronous Mode - Alternate](#) for timing information.
- (3) The internal pull resistors for balls K7, M7, J5, K6, J4, J6, H4, H5 are permanently disabled when sysboot15 is set to 1 as described in the *Sysboot Configuration* section in the device TRM. If internal pull-up/down resistors are desired on these balls then sysboot15 should be set to 0. If gpmc boot mode is used with SYSBOOT15 = 1 (not recommended) then external pull-downs should be implemented to keep the address bus at logic-0 value during boot since the gpmc ms-address bits are Hi-Z during boot.

### 4.3.6 Timer

---

#### NOTE

For more information, see the *Timers* section in the device TRM.

---

**Table 4-7. Timer Signal Descriptions**

SIGNAL NAME	DESCRIPTION	TYPE	BALL
timer1	PWM output/event trigger input	IO	M4/ E21
timer2	PWM output/event trigger input	IO	N6/ F20
timer3	PWM output/event trigger input	IO	N1/ F21
timer4	PWM output/event trigger input	IO	P7/ D12
timer5	PWM output/event trigger input	IO	U2/ B12
timer6	PWM output/event trigger input	IO	T2/ A11
timer7	PWM output/event trigger input	IO	R3/ B13
timer8	PWM output/event trigger input	IO	P4/ A12
timer9	PWM output/event trigger input	IO	P9/ E14
timer10	PWM output/event trigger input	IO	N9/ A13
timer11	PWM output/event trigger input	IO	R4/ G14
timer12	PWM output/event trigger input	IO	N7/ F14
timer13	PWM output/event trigger input	IO	D18/ AF8
timer14	PWM output/event trigger input	IO	E17/ AE9
timer15	PWM output/event trigger input	IO	B26/ AF9/ AC10
timer16	PWM output/event trigger input	IO	C23/ AD9/ AB10

### 4.3.7 I2C

---

#### NOTE

For more information, see the *Serial Communication Interface / Multimaster High Speed I2C Controller / HS I2C Environment / HS I2C in I2C Mode* section in the device TRM.

---

**NOTE**

I2C1 and I2C2 do NOT support HS-mode.

**Table 4-8. I2C Signal Descriptions**

SIGNAL NAME	DESCRIPTION	TYPE	BALL
<b>Inter-Integrated Circuit Interface 1 (I2C1)</b>			
i2c1_scl	I2C1 Clock	IOD	C20
i2c1_sda	I2C1 Data	IOD	C21
<b>Inter-Integrated Circuit Interface 2 (I2C2)</b>			
i2c2_scl	I2C2 Clock	IOD	F17
i2c2_sda	I2C2 Data	IOD	C25
<b>Inter-Integrated Circuit Interface 3 (I2C3)</b>			
i2c3_scl	I2C3 Clock	IOD	P7/ D14/ AB4/ F20
i2c3_sda	I2C3 Data	IOD	N1/ C14/ AC5/ E21
<b>Inter-Integrated Circuit Interface 4 (I2C4)</b>			
i2c4_scl	I2C4 Clock	IOD	R6/ J14/ A21/ Y9
i2c4_sda	I2C4 Data	IOD	T9/ B14/ C18/ W7
<b>Inter-Integrated Circuit Interface 5 (I2C5)</b>			
i2c5_scl	I2C5 Clock	IOD	AB9/ P6/ F12
i2c5_sda	I2C5 Data	IOD	AA3/ R9/ G12

**4.3.8 HDQ1W****NOTE**

For more information, see the *Serial Communication Interface / HDQ/1-Wire* section in the device TRM.

**Table 4-9. HDQ / 1-Wire Signal Descriptions**

SIGNAL NAME	DESCRIPTION	TYPE	BALL
hdq0	HDQ or 1-wire protocol single interface pin	IOD	D18/ C23

**4.3.9 UART****NOTE**

For more information, see the *Serial Communication Interface / UART/IrDA/CIR* section in the device TRM.

**Table 4-10. UART Signal Descriptions**

SIGNAL NAME	DESCRIPTION	TYPE	BALL
<b>Universal Asynchronous Receiver/Transmitter 1 (UART1)</b>			
uart1_dcdn	UART1 Data Carrier Detect active low	I	D28
uart1_dsrn	UART1 Data Set Ready active low	I	D26
uart1_dtrn	UART1 Data Terminal Ready active low	O	D27
uart1_rin	UART1 Ring Indicator	I	C28
uart1_rxd	UART1 Receive Data	I	B27
uart1_txd	UART1 Transmit Data	O	C26
uart1_ctsn	UART1 Clear to Send active low	I	E25



**Table 4-10. UART Signal Descriptions (continued)**

SIGNAL NAME	DESCRIPTION	TYPE	BALL
uart1_rtsn	UART1 Request to Send active low	O	C27
<b>Universal Asynchronous Receiver/Transmitter 2 (UART2)</b>			
uart2_rxd	UART2 Receive Data	I	D28
uart2_txd	UART2 Transmit Data	O	D26
uart2_ctsn	UART2 Clear to Send active low	I	D27
uart2_rtsn	UART2 Request to Send active low	O	C28
<b>Universal Asynchronous Receiver/Transmitter 3 (UART3)/IrDA</b>			
uart3_rxd	UART3 Receive Data for both normal UART mode and IrDA mode.	I	V2/ AB3/ A26 / D27
uart3_txd	UART3 Transmit Data	O	Y1/ AA4/ B22/ C28
uart3_ctsn	UART3 Clear to Send active low	I	U4/ W9/ G17/ D28
uart3_rtsn	UART3 Request to Send active low	O	V1/ V9/ D26/ B24
uart3_rctx	Remote control data	O	D28
uart3_sd	Infrared transceiver configure/shutdown	O	D26
uart3_irtx	Infrared data output	O	C28
<b>Universal Asynchronous Receiver/Transmitter 4 (UART4)</b>			
uart4_rxd	UART4 Receive Data	I	V7/ G16/ B21
uart4_txd	UART4 Transmit Data	O	U7/ D17/ B20
uart4_ctsn	UART4 Clear to Send active low	I	V6
uart4_rtsn	UART4 Request to Send active low	O	U6
<b>Universal Asynchronous Receiver/Transmitter 5 (UART5)</b>			
uart5_rxd	UART5 Receive Data	I	R6/ F11/ B19/ AC7/ G17
uart5_txd	UART5 Transmit Data	O	T9/ G10/ C17/ AC6/ B24
uart5_ctsn	UART5 Clear to Send active low	I	T6/ AC9
uart5_rtsn	UART5 Request to Send active low	O	T7/ AC3
<b>Universal Asynchronous Receiver/Transmitter 6 (UART6)</b>			
uart6_rxd	UART6 Receive Data	I	P6/ E8/ G12/ W7
uart6_txd	UART6 Transmit Data	O	R9/ D9/ F12/ Y9
uart6_ctsn	UART6 Clear to Send active low	I	R5/ G13
uart6_rtsn	UART6 Request to Send active low	O	P5/ J11
<b>Universal Asynchronous Receiver/Transmitter 7 (UART7)</b>			
uart7_rxd	UART7 Receive Data	I	T6/ AD9/ B7/ B18
uart7_txd	UART7 Transmit Data	O	T7/ AF9/ B8/ F15
uart7_ctsn	UART7 Clear to Send active low	I	AE9/ B19
uart7_rtsn	UART7 Request to Send active low	O	AF8/ C17
<b>Universal Asynchronous Receiver/Transmitter 8 (UART8)</b>			
uart8_rxd	UART8 Receive Data	I	AE8/ R5/ C18/ G20
uart8_txd	UART8 Transmit Data	O	AD8/ P5/ A21/ G19
uart8_ctsn	UART8 Clear to Send active low	I	AG7/ G16
uart8_rtsn	UART8 Request to Send active low	O	AH6/ D17
<b>Universal Asynchronous Receiver/Transmitter 9 (UART9)</b>			
uart9_rxd	UART9 Receive Data	I	G1/ AA3/ E25
uart9_txd	UART9 Transmit Data	O	G6/ AB9/ C27
uart9_ctsn	UART9 Clear to Send active low	I	F2/ AB3
uart9_rtsn	UART9 Request to Send active low	O	F3/ AA4
<b>Universal Asynchronous Receiver/Transmitter 10 (UART10)</b>			
uart10_rxd	UART10 Receive Data	I	D1/ E21/ AC8/ D27

**Table 4-10. UART Signal Descriptions (continued)**

SIGNAL NAME	DESCRIPTION	TYPE	BALL
uart10_txd	UART10 Transmit Data	O	E2/ F20/ AD6/ C28
uart10_ctsn	UART10 Clear to Send active low	I	D2/ AB8
uart10_rtsn	UART10 Request to Send active low	O	F4/ AB5

**4.3.10 McSPI****CAUTION**

The I/O timings provided in [Section 5.10, Timing Requirements and Switching Characteristics](#) are applicable for all combinations of signals for SPI1 and SPI2. However, the timings are valid only for SPI3 and SPI4 if signals within a single IOSET are used. The IOSETS are defined in the [Table 5-76](#).

**NOTE**

For more information, see the *Serial Communication Interface / Multichannel Serial Peripheral Interface* section in the device TRM.

**Table 4-11. SPI Signal Descriptions**

SIGNAL NAME	DESCRIPTION	TYPE	BALL
<b>Serial Peripheral Interface 1</b>			
spi1_sclk <sup>(1)</sup>	SPI1 Clock	IO	A25
spi1_d1	SPI1 Data. Can be configured as either MISO or MOSI.	IO	F16
spi1_d0	SPI1 Data. Can be configured as either MISO or MOSI.	IO	B25
spi1_cs0	SPI1 Chip Select	IO	A24
spi1_cs1	SPI1 Chip Select	IO	A22
spi1_cs2	SPI1 Chip Select	IO	B21
spi1_cs3	SPI1 Chip Select	IO	B20
<b>Serial Peripheral Interface 2</b>			
spi2_sclk <sup>(1)</sup>	SPI2 Clock	IO	A26
spi2_d1	SPI2 Data. Can be configured as either MISO or MOSI.	IO	B22
spi2_d0	SPI2 Data. Can be configured as either MISO or MOSI.	IO	G17
spi2_cs0	SPI2 Chip Select	IO	B24
spi2_cs1	SPI2 Chip Select	IO	A22
spi2_cs2	SPI2 Chip Select	IO	B21
spi2_cs3	SPI2 Chip Select	IO	B20
<b>Serial Peripheral Interface 3</b>			
spi3_sclk <sup>(1)</sup>	SPI3 Clock	IO	AD9 / V2 / B12 / E11 / AC4 / C18
spi3_d1	SPI3 Data. Can be configured as either MISO or MOSI.	IO	AF9 / Y1 / B10 / A11 / A21 / AC7
spi3_d0	SPI3 Data. Can be configured as either MISO or MOSI.	IO	AE9 / W9 / C11 / B13 / AC6 / G16
spi3_cs0	SPI3 Chip Select	IO	AF8 / V9 / D11 / A12 / AC9 / D17
spi3_cs1	SPI3 Chip Select	IO	B11 / AC3 / E14
spi3_cs2	SPI3 Chip Select	IO	F11
spi3_cs3	SPI3 Chip Select	IO	A10

**Table 4-11. SPI Signal Descriptions (continued)**

SIGNAL NAME	DESCRIPTION	TYPE	BALL
<b>Serial Peripheral Interface 4</b>			
spi4_sclk <sup>(1)</sup>	SPI4 Clock	IO	N7 / G1 / AA3 / V7 / AC8
spi4_d1	SPI4 Data. Can be configured as either MISO or MOSI.	IO	R4 / G6 / AB9 / U7 / AD6
spi4_d0	SPI4 Data. Can be configured as either MISO or MOSI.	IO	N9 / F2 / AB3 / V6 / AB8
spi4_cs0	SPI4 Chip Select	IO	P9 / F3 / AA4 / U6 / AB5
spi4_cs1	SPI4 Chip Select	IO	P4 / Y1
spi4_cs2	SPI4 Chip Select	IO	R3 / W9
spi4_cs3	SPI4 Chip Select	IO	T2 / V9

(1) This clock signal is implemented as 'pad loopback' inside the device - the output signal is looped back through the input buffer to serve as the internal reference signal. Series termination is recommended (as close to device pin as possible) to improve signal integrity of the clock input. Any nonmonotonicity in voltage that occurs at the pad loopback clock pin between  $V_{IH}$  and  $V_{IL}$  must be less than  $V_{HYS}$ .

### 4.3.11 QSPI

#### NOTE

For more information, see the *Serial Communication Interface / Quad Serial Peripheral Interface* section in the device TRM.

**Table 4-12. QSPI Signal Descriptions**

SIGNAL NAME	DESCRIPTION	TYPE	BALL
qspi1_sclk	QSPI1 Serial Clock	O	R2
qspi1_rtclk	QSPI1 Return Clock Input. Must be connected from QSPI1_SCLK on PCB. Refer to PCB Guidelines for QSPI1.	I	R3
qspi1_d0	QSPI1 Data[0]. This pin is output data for all commands/writes and for dual read and quad read modes it becomes input data pin during read phase.	IO	U1
qspi1_d1	QSPI1 Data[1]. Input read data in all modes.	I	P3
qspi1_d2	QSPI1 Data[2]. This pin is used only in quad read mode as input data pin during read phase	I	U2
qspi1_d3	QSPI1 Data[3]. This pin is used only in quad read mode as input data pin during read phase	I	T2
qspi1_cs0	QSPI1 Chip Select[0]. This pin is Used for QSPI1 boot modes.	O	P2
qspi1_cs1	QSPI1 Chip Select[1]	O	P1
qspi1_cs2	QSPI1 Chip Select[2]	O	T7
qspi1_cs3	QSPI1 Chip Select[3]	O	P6

### 4.3.12 McASP

#### NOTE

For more information, see the *Serial Communication Interface / Multichannel Audio Serial Port (McASP)* section in the device TRM.

**Table 4-13. McASP Signal Descriptions**

SIGNAL NAME	DESCRIPTION	TYPE	BALL
<b>Multichannel Audio Serial Port 1</b>			
mcasp1_axr0	McASP1 Transmit/Receive Data	IO	G12

**Table 4-13. McASP Signal Descriptions (continued)**

SIGNAL NAME	DESCRIPTION	TYPE	BALL
mcasp1_axr1	McASP1 Transmit/Receive Data	IO	F12
mcasp1_axr2	McASP1 Transmit/Receive Data	IO	G13
mcasp1_axr3	McASP1 Transmit/Receive Data	IO	J11
mcasp1_axr4	McASP1 Transmit/Receive Data	IO	D18 / E12
mcasp1_axr5	McASP1 Transmit/Receive Data	IO	E17 / F13
mcasp1_axr6	McASP1 Transmit/Receive Data	IO	B26 / C12
mcasp1_axr7	McASP1 Transmit/Receive Data	IO	C23 / D12
mcasp1_axr8	McASP1 Transmit/Receive Data	IO	E21 / B12
mcasp1_axr9	McASP1 Transmit/Receive Data	IO	F20 / A11
mcasp1_axr10	McASP1 Transmit/Receive Data	IO	F21 / B13
mcasp1_axr11	McASP1 Transmit/Receive Data	IO	A12
mcasp1_axr12	McASP1 Transmit/Receive Data	IO	E14
mcasp1_axr13	McASP1 Transmit/Receive Data	IO	A13
mcasp1_axr14	McASP1 Transmit/Receive Data	IO	G14
mcasp1_axr15	McASP1 Transmit/Receive Data	IO	F14
mcasp1_fsx	McASP1 Transmit Frame Sync	IO	D14
mcasp1_aclkr <sup>(1)</sup>	McASP1 Receive Bit Clock	IO	B14
mcasp1_fsr	McASP1 Receive Frame Sync	IO	J14
mcasp1_ahclkx	McASP1 Transmit High-Frequency Master Clock	O	D18
mcasp1_aclkx <sup>(1)</sup>	McASP1 Transmit Bit Clock	IO	C14
<b>Multichannel Audio Serial Port 2</b>			
mcasp2_axr0	McASP2 Transmit/Receive Data	IO	B15
mcasp2_axr1	McASP2 Transmit/Receive Data	IO	A15
mcasp2_axr2	McASP2 Transmit/Receive Data	IO	C15
mcasp2_axr3	McASP2 Transmit/Receive Data	IO	A16
mcasp2_axr4	McASP2 Transmit/Receive Data	IO	D15
mcasp2_axr5	McASP2 Transmit/Receive Data	IO	B16
mcasp2_axr6	McASP2 Transmit/Receive Data	IO	B17
mcasp2_axr7	McASP2 Transmit/Receive Data	IO	A17
mcasp2_axr8	McASP2 Transmit/Receive Data	IO	D18
mcasp2_axr9	McASP2 Transmit/Receive Data	IO	E17
mcasp2_axr10	McASP2 Transmit/Receive Data	IO	B26
mcasp2_axr11	McASP2 Transmit/Receive Data	IO	C23
mcasp2_axr12	McASP2 Transmit/Receive Data	IO	B18
mcasp2_axr13	McASP2 Transmit/Receive Data	IO	F15
mcasp2_axr14	McASP2 Transmit/Receive Data	IO	B19
mcasp2_axr15	McASP2 Transmit/Receive Data	IO	C17
mcasp2_fsx	McASP2 Transmit Frame Sync	IO	A18
mcasp2_aclkr <sup>(1)</sup>	McASP2 Receive Bit Clock	IO	E15
mcasp2_fsr	McASP2 Receive Frame Sync	IO	A20
mcasp2_ahclkx	McASP2 Transmit High-Frequency Master Clock	O	E17
mcasp2_aclkx <sup>(1)</sup>	McASP2 Transmit Bit Clock	IO	A19
<b>Multichannel Audio Serial Port 3</b>			
mcasp3_axr0	McASP3 Transmit/Receive Data	IO	B19
mcasp3_axr1	McASP3 Transmit/Receive Data	IO	C17
mcasp3_axr2	McASP3 Transmit/Receive Data	IO	C15
mcasp3_axr3	McASP3 Transmit/Receive Data	IO	A16

**Table 4-13. McASP Signal Descriptions (continued)**

SIGNAL NAME	DESCRIPTION	TYPE	BALL
mcasp3_fsx	McASP3 Transmit Frame Sync	IO	F15
mcasp3_ahclkx	McASP3 Transmit High-Frequency Master Clock	O	B26
mcasp3_aclkx <sup>(1)</sup>	McASP3 Transmit Bit Clock	IO	B18
mcasp3_aclkr <sup>(1)</sup>	McASP3 Receive Bit Clock	IO	B18
mcasp3_fsr	McASP3 Receive Frame Sync	IO	F15
<b>Multichannel Audio Serial Port 4</b>			
mcasp4_axr0	McASP4 Transmit/Receive Data	IO	G16
mcasp4_axr1	McASP4 Transmit/Receive Data	IO	D17
mcasp4_axr2	McASP4 Transmit/Receive Data	IO	E12
mcasp4_axr3	McASP4 Transmit/Receive Data	IO	F13
mcasp4_fsx	McASP4 Transmit Frame Sync	IO	A21
mcasp4_ahclkx	McASP4 Transmit High-Frequency Master Clock	O	C23
mcasp4_aclkx <sup>(1)</sup>	McASP4 Transmit Bit Clock	IO	C18
mcasp4_aclkr <sup>(1)</sup>	McASP4 Receive Bit Clock	IO	C18
mcasp4_fsr	McASP4 Receive Frame Sync	IO	A21
<b>Multichannel Audio Serial Port 5</b>			
mcasp5_axr0	McASP5 Transmit/Receive Data	IO	AB3
mcasp5_axr1	McASP5 Transmit/Receive Data	IO	AA4
mcasp5_axr2	McASP5 Transmit/Receive Data	IO	C12
mcasp5_axr3	McASP5 Transmit/Receive Data	IO	D12
mcasp5_fsx	McASP5 Transmit Frame Sync	IO	AB9
mcasp5_ahclkx	McASP5 Transmit High-Frequency Master Clock	O	D18
mcasp5_aclkx <sup>(1)</sup>	McASP5 Transmit Bit Clock	IO	AA3
mcasp5_aclkr <sup>(1)</sup>	McASP5 Receive Bit Clock	IO	AA3
mcasp5_fsr	McASP5 Receive Frame Sync	IO	AB9
<b>Multichannel Audio Serial Port 6</b>			
mcasp6_axr0	McASP6 Transmit/Receive Data	IO	B12
mcasp6_axr1	McASP6 Transmit/Receive Data	IO	A11
mcasp6_axr2	McASP6 Transmit/Receive Data	IO	G13
mcasp6_axr3	McASP6 Transmit/Receive Data	IO	J11
mcasp6_ahclkx	McASP6 Transmit High-Frequency Master Clock	O	E17
mcasp6_aclkx <sup>(1)</sup>	McASP6 Transmit Bit Clock	IO	B13
mcasp6_fsx	McASP6 Transmit Frame Sync	IO	A12
mcasp6_aclkr <sup>(1)</sup>	McASP6 Receive Bit Clock	IO	B13
mcasp6_fsr	McASP6 Receive Frame Sync	IO	A12
<b>Multichannel Audio Serial Port 7</b>			
mcasp7_axr0	McASP7 Transmit/Receive Data	IO	E14
mcasp7_axr1	McASP7 Transmit/Receive Data	IO	A13
mcasp7_axr2	McASP7 Transmit/Receive Data	IO	B14
mcasp7_axr3	McASP7 Transmit/Receive Data	IO	J14
mcasp7_ahclkx	McASP7 Transmit High-Frequency Master Clock	O	B26
mcasp7_aclkx <sup>(1)</sup>	McASP7 Transmit Bit Clock	IO	G14
mcasp7_fsx	McASP7 Transmit Frame Sync	IO	F14
mcasp7_aclkr <sup>(1)</sup>	McASP7 Receive Bit Clock	IO	G14
mcasp7_fsr	McASP7 Receive Frame Sync	IO	F14
<b>Multichannel Audio Serial Port 8</b>			
mcasp8_axr0	McASP8 Transmit/Receive Data	IO	D15

**Table 4-13. McASP Signal Descriptions (continued)**

SIGNAL NAME	DESCRIPTION	TYPE	BALL
mcasp8_axr1	McASP8 Transmit/Receive Data	IO	B16
mcasp8_axr2	McASP8 Transmit/Receive Data	IO	E15
mcasp8_axr3	McASP8 Transmit/Receive Data	IO	A20
mcasp8_ahclkx	McASP8 Transmit High-Frequency Master Clock	O	C23
mcasp8_aclkx <sup>(1)</sup>	McASP8 Transmit Bit Clock	IO	B17
mcasp8_fsx	McASP8 Transmit Frame Sync	IO	A17
mcasp8_aclkr <sup>(1)</sup>	McASP8 Receive Bit Clock	IO	B17
mcasp8_fsr	McASP8 Receive Frame Sync	IO	A17

(1) This clock signal is implemented as 'pad loopback' inside the device - the output signal is looped back through the input buffer to serve as the internal reference signal. Series termination is recommended (as close to device pin as possible) to improve signal integrity of the clock input. Any nonmonotonicity in voltage that occurs at the pad loopback clock pin between  $V_{IH}$  and  $V_{IL}$  must be less than  $V_{HYS}$ .

### 4.3.13 USB

#### NOTE

For more information, see the *Serial Communication Interface / SuperSpeed USB DRD* section in the device TRM.

**Table 4-14. USB Signal Descriptions**

SIGNAL NAME	DESCRIPTION	TYPE	BALL
<b>Universal Serial Bus 1</b>			
usb1_dp	USB1 USB2.0 differential signal pair (positive)	IODS	AD12
usb1_dm	USB1 USB2.0 differential signal pair (negative)	IODS	AC12
usb1_drvvbus	USB1 Drive VBUS signal	O	AB10
usb_rxn0	USB1 USB3.0 receiver negative lane	IDS	AF12
usb_rxp0	USB1 USB3.0 receiver positive lane	IDS	AE12
usb_txn0	USB1 USB3.0 transmitter negative lane	ODS	AC11
usb_tpx0	USB1 USB3.0 transmitter positive lane	ODS	AD11
<b>Universal Serial Bus 2</b>			
usb2_dp	USB2 USB2.0 differential signal pair (positive)	IODS	AE11
usb2_dm	USB2 USB2.0 differential signal pair (negative)	IODS	AF11
usb2_drvvbus	USB2 Drive VBUS signal	O	AC10

### 4.3.14 SATA

#### NOTE

For more information, see the *Serial Communication Interfaces / SATA Controller* section in the device TRM.

**Table 4-15. SATA Signal Descriptions**

SIGNAL NAME	DESCRIPTION	TYPE	BALL
sata1_rxn0	SATA differential negative receiver lane 0	IDS	AH9
sata1_rxp0	SATA differential positive receiver lane 0	IDS	AG9
sata1_txn0	SATA differential negative transmitter lane 0	ODS	AG10
sata1_tpx0	SATA differential positive transmitter lane 0	ODS	AH10
sata1_led	SATA channel activity indicator	O	A22 / G19

### 4.3.15 PCIe

#### NOTE

For more information, see the *Serial Communication Interfaces / PCIe Controllers* and the *Shared PHY Component Subsystems / PCIe PHY Subsystem* sections in the device TRM.

**Table 4-16. PCIe Signal Descriptions**

SIGNAL NAME	DESCRIPTION	TYPE	BALL
pcie_rxn0	PCle1_PHY_RX Receive Data Lane 0 (negative) - mapped to PCle_SS1 only.	IDS	AG13
pcie_rxp0	PCle1_PHY_RX Receive Data Lane 0 (positive) - mapped to PCle_SS1 only.	IDS	AH13
pcie_txn0	PCle1_PHY_TX Transmit Data Lane 0 (negative) - mapped to PCle_SS1 only.	ODS	AG14
pcie_txp0	PCle1_PHY_TX Transmit Data Lane 0 (positive) - mapped to PCle_SS1 only.	ODS	AH14
pcie_rxn1	PCle2_PHY_RX Receive Data Lane 1 (negative) - mapped to either PCle_SS1 (dual-lane mode) or PCle_SS2 (single-lane mode)	IDS	AG11
pcie_rxp1	PCle2_PHY_RX Receive Data Lane 1 (positive) - mapped to either PCle_SS1 (dual-lane mode) or PCle_SS2 (single-lane mode)	IDS	AH11
pcie_txn1	PCle2_PHY_TX Transmit Data Lane 1 (negative) - mapped to either PCle_SS1 (dual-lane mode) or PCle_SS2 (single-lane mode)	ODS	AG12
pcie_txp1	PCle2_PHY_TX Transmit Data Lane 1 (positive) - mapped to either PCle_SS1 (dual-lane mode) or PCle_SS2 (single-lane mode)	ODS	AH12
ljcb_clkp	PCle1_PHY / PCle2_PHY shared Reference Clock Input / Output Differential Pair (positive)	IODS	AG15
ljcb_clkn	PCle1_PHY / PCle2_PHY shared Reference Clock Input / Output Differential Pair (negative)	IODS	AH15

### 4.3.16 DCAN and MCAN

#### NOTE

For more information, see the *Serial Communication Interface / DCAN and MCAN* section in the device TRM.

**Table 4-17. DCAN Signal Descriptions**

SIGNAL NAME	DESCRIPTION	TYPE	BALL
<b>DCAN 1</b>			
dcan1_tx	DCAN1 transmit data pin	IO	G20
dcan1_rx	DCAN1 receive data pin	IO	G19 / AD17
<b>DCAN 2</b>			
dcan2_tx	DCAN2 transmit data pin	IO	E21 / B21
dcan2_rx	DCAN2 receive data pin	IO	F20 / AC17 / B20
<b>MCAN</b>			
mcan_tx	MCAN transmit data pin	IO	E21 / G20
mcan_rx	MCAN receive data pin	IO	F20 / G19

### 4.3.17 GMAC\_SW

#### CAUTION

The I/O timings provided in [Section 5.10, Timing Requirements and Switching Characteristics](#) are valid only if signals within a single IOSET are used. The IOSETs are defined in the [Table 5-103](#), [Table 5-106](#), [Table 5-111](#), and [Table 5-118](#).

#### NOTE

For more information, see the *Serial Communication Interfaces / Ethernet Controller* section in the device TRM.

**Table 4-18. GMAC Signal Descriptions**

SIGNAL NAME	DESCRIPTION	TYPE	BALL
rgmii0_txc	RGMIIO Transmit Clock	O	W9
rgmii0_txctl	RGMIIO Transmit Enable	O	V9
rgmii0_txd3	RGMIIO Transmit Data	O	V7
rgmii0_txd2	RGMIIO Transmit Data	O	U7
rgmii0_txd1	RGMIIO Transmit Data	O	V6
rgmii0_txd0	RGMIIO Transmit Data	O	U6
rgmii0_rxc	RGMIIO Receive Clock	I	U5
rgmii0_rxctl	RGMIIO Receive Control	I	V5
rgmii0_rxd3	RGMIIO Receive Data	I	V4
rgmii0_rxd2	RGMIIO Receive Data	I	V3
rgmii0_rxd1	RGMIIO Receive Data	I	Y2
rgmii0_rxd0	RGMIIO Receive Data	I	W2
rgmii1_txc	RGMIIO1 Transmit Clock	O	D5
rgmii1_txctl	RGMIIO1 Transmit Enable	O	C2
rgmii1_txd3	RGMIIO1 Transmit Data	O	C3
rgmii1_txd2	RGMIIO1 Transmit Data	O	C4
rgmii1_txd1	RGMIIO1 Transmit Data	O	B2
rgmii1_txd0	RGMIIO1 Transmit Data	O	D6
rgmii1_rxc	RGMIIO1 Receive Clock	I	C5
rgmii1_rxctl	RGMIIO1 Receive Control	I	A3
rgmii1_rxd3	RGMIIO1 Receive Data	I	B3
rgmii1_rxd2	RGMIIO1 Receive Data	I	B4
rgmii1_rxd1	RGMIIO1 Receive Data	I	B5
rgmii1_rxd0	RGMIIO1 Receive Data	I	A4
mii1_rxd1	MII1 Receive Data	I	C1
mii1_rxd2	MII1 Receive Data	I	E4
mii1_rxd3	MII1 Receive Data	I	F5
mii1_rxd0	MII1 Receive Data	I	E6
mii1_rxclk	MII1 Receive Clock	I	D5
mii1_rxdv	MII1 Receive Data Valid	I	C2
mii1_txclk	MII1 Transmit Clock	I	C3
mii1_txd0	MII1 Transmit Data	O	C4
mii1_txd1	MII1 Transmit Data	O	B2



**Table 4-18. GMAC Signal Descriptions (continued)**

SIGNAL NAME	DESCRIPTION	TYPE	BALL
mii1_txd2	MII1 Transmit Data	O	D6
mii1_txd3	MII1 Transmit Data	O	C5
mii1_txer	MII1 Transmit Error	I	A3
mii1_rxer	MII1 Receive Data Error	I	B3
mii1_col	MII1 Collision Detect (Sense)	I	B4
mii1_crs	MII1 Carrier Sense	I	B5
mii1_txen	MII1 Transmit Data Enable	O	A4
mii0_rxd1	MII0 Receive Data	I	V6
mii0_rxd2	MII0 Receive Data	I	V9
mii0_rxd3	MII0 Receive Data	I	W9
mii0_rxd0	MII0 Receive Data	I	U6
mii0_rxclk	MII0 Receive Clock	I	Y1
mii0_rxdv	MII0 Receive Data Valid	I	V2
mii0_txclk	MII0 Transmit Clock	I	U5
mii0_txd0	MII0 Transmit Data	O	W2
mii0_txd1	MII0 Transmit Data	O	Y2
mii0_txd2	MII0 Transmit Data	O	V4
mii0_txd3	MII0 Transmit Data	O	V5
mii0_txer	MII0 Transmit Error	I	U4
mii0_rxer	MII0 Receive Data Error	I	U7
mii0_col	MII0 Collision Detect (Sense)	I	V1
mii0_crs	MII0 Carrier Sense	I	V7
mii0_txen	MII0 Transmit Data Enable	O	V3
rmii0_crs	RMII0 Carrier Sense	I	V7
rmii0_rxer	RMII0 Receive Data Error	I	U7
rmii0_rxd1	RMII0 Receive Data	I	V6
rmii0_rxd0	RMII0 Receive Data	I	U6
rmii0_txen	RMII0 Transmit Data Enable	O	V3
rmii1_crs	RMII1 Carrier Sense	I	V2
rmii1_rxer	RMII1 Receive Data Error	I	Y1
rmii1_rxd1	RMII1 Receive Data	I	W9
rmii1_rxd0	RMII1 Receive Data	I	V9
rmii1_txen	RMII1 Transmit Data Enable	O	U5
rmii1_txd1	RMII1 Transmit Data	O	V5
rmii1_txd0	RMII1 Transmit Data	O	V4
rmii0_txd1	RMII0 Transmit Data	O	Y2
rmii0_txd0	RMII0 Transmit Data	O	W2
mdio_d	MDIO Data	O	AB4 / B20 / F6 / U4
mdio_mclk	MDIO Clock	O	AC5 / B21 / D3 / V1

#### 4.3.18 MLB

#### NOTE

Media Local Bus (MLB) is not available on this device and balls listed in [Table 4-19](#) must be left unconnected.

**Table 4-19. MLB Signal Descriptions**

SIGNAL NAME	DESCRIPTION	TYPE	BALL
mlbp_sig_p	Media Local Bus (MLB) Subsystem signal differential pair (positive)	IODS	AC1
mlbp_sig_n	Media Local Bus (MLB) Subsystem signal differential pair (negative)	IODS	AC2
mlbp_dat_p	Media Local Bus (MLB) Subsystem data differential pair (positive)	IODS	AA1
mlbp_dat_n	Media Local Bus (MLB) Subsystem data differential pair (negative)	IODS	AA2
mlbp_clk_p	Media Local Bus (MLB) Subsystem clock differential pair (positive)	IDS	AB1
mlbp_clk_n	Media Local Bus (MLB) Subsystem clock differential pair (negative)	IDS	AB2

**4.3.19 eMMC/SD/SDIO****NOTE**

For more information, see the *HS MMC/SDIO* section in the device TRM.

**Table 4-20. eMMC/SD/SDIO Signal Descriptions**

SIGNAL NAME	DESCRIPTION	TYPE	BALL
<b>Multi Media Card 1</b>			
mmc1_clk <sup>(1)</sup>	MMC1 clock	IO	W6
mmc1_cmd	MMC1 command	IO	Y6
mmc1_sdcd	MMC1 Card Detect	I	W7
mmc1_sdwp	MMC1 Write Protect	I	Y9
mmc1_dat0	MMC1 data bit 0	IO	AA6
mmc1_dat1	MMC1 data bit 1	IO	Y4
mmc1_dat2	MMC1 data bit 2	IO	AA5
mmc1_dat3	MMC1 data bit 3	IO	Y3
<b>Multi Media Card 2</b>			
mmc2_clk <sup>(1)</sup>	MMC2 clock	IO	J7
mmc2_cmd	MMC2 command	IO	H6
mmc2_sdcd	MMC2 Card Detect	I	G20
mmc2_sdwp	MMC2 Write Protect	I	G19
mmc2_dat0	MMC2 data bit 0	IO	J4
mmc2_dat1	MMC2 data bit 1	IO	J6
mmc2_dat2	MMC2 data bit 2	IO	H4
mmc2_dat3	MMC2 data bit 3	IO	H5
mmc2_dat4	MMC2 data bit 4	IO	K7
mmc2_dat5	MMC2 data bit 5	IO	M7
mmc2_dat6	MMC2 data bit 6	IO	J5
mmc2_dat7	MMC2 data bit 7	IO	K6
<b>Multi Media Card 3</b>			
mmc3_clk <sup>(1)</sup>	MMC3 clock	IO	AD4
mmc3_cmd	MMC3 command	IO	AC4
mmc3_sdcd	MMC3 Card Detect	I	B21
mmc3_sdwp	MMC3 Write Protect	I	B20
mmc3_dat0	MMC3 data bit 0	IO	AC7
mmc3_dat1	MMC3 data bit 1	IO	AC6
mmc3_dat2	MMC3 data bit 2	IO	AC9
mmc3_dat3	MMC3 data bit 3	IO	AC3
mmc3_dat4	MMC3 data bit 4	IO	AC8

**Table 4-20. eMMC/SD/SDIO Signal Descriptions (continued)**

SIGNAL NAME	DESCRIPTION	TYPE	BALL
mmc3_dat5	MMC3 data bit 5	IO	AD6
mmc3_dat6	MMC3 data bit 6	IO	AB8
mmc3_dat7	MMC3 data bit 7	IO	AB5
<b>Multi Media Card 4</b>			
mmc4_clk <sup>(1)</sup>	MMC4 clock	IO	E25
mmc4_cmd	MMC4 command	IO	C27
mmc4_sdcd	MMC4 Card Detect	I	B27
mmc4_sdwp	MMC4 Write Protect	I	C26
mmc4_dat0	MMC4 data bit 0	IO	D28
mmc4_dat1	MMC4 data bit 1	IO	D26
mmc4_dat2	MMC4 data bit 2	IO	D27
mmc4_dat3	MMC4 data bit 3	IO	C28

(1) By default, this clock signal is implemented as 'pad loopback' inside the device - the output signal is looped back through the input buffer to serve as the internal reference signal. mmc1\_clk and mmc2\_clk have an optional software programmable setting to use an 'internal loopback clock' instead of the default 'pad loopback clock'. If the 'pad loopback clock' is used, series termination is recommended (as close to device pin as possible) to improve signal integrity of the clock input. Any nonmonotonicity in voltage that occurs at the pad loopback clock pin between  $V_{IH}$  and  $V_{IL}$  must be less than  $V_{HYS}$ .

### 4.3.20 GPIO

#### NOTE

For more information, see the *General-Purpose Interface* section in the device TRM.

**Table 4-21. GPIOs Signal Descriptions**

SIGNAL NAME	DESCRIPTION	TYPE	BALL
<b>GPIO 1</b>			
gpio1_0	General-Purpose Input	I	AD17
gpio1_1	General-Purpose Input	I	AC17
gpio1_2	General-Purpose Input	I	AB16
gpio1_3	General-Purpose Input	I	AC16
gpio1_4	General-Purpose Input/Output	IO	D15
gpio1_5	General-Purpose Input/Output	IO	A17
gpio1_6	General-Purpose Input/Output	IO	M6
gpio1_7	General-Purpose Input/Output	IO	M2
gpio1_8	General-Purpose Input/Output	IO	L5
gpio1_9	General-Purpose Input/Output	IO	M1
gpio1_10	General-Purpose Input/Output	IO	L6
gpio1_11	General-Purpose Input/Output	IO	L4
gpio1_12	General-Purpose Input/Output	IO	L3
gpio1_13	General-Purpose Input/Output	IO	L2
gpio1_14	General-Purpose Input/Output	IO	G20
gpio1_15	General-Purpose Input/Output	IO	G19
gpio1_16	General-Purpose Input/Output	IO	D27
gpio1_17	General-Purpose Input/Output	IO	C28
gpio1_18	General-Purpose Input/Output	IO	H1
gpio1_19	General-Purpose Input/Output	IO	J3
gpio1_20	General-Purpose Input/Output	IO	H2
gpio1_21	General-Purpose Input/Output	IO	H3

**Table 4-21. GPIOs Signal Descriptions (continued)**

SIGNAL NAME	DESCRIPTION	TYPE	BALL
gpio1_22	General-Purpose Input/Output	IO	AC8
gpio1_23	General-Purpose Input/Output	IO	AD6
gpio1_24	General-Purpose Input/Output	IO	AB8
gpio1_25	General-Purpose Input/Output	IO	AB5
gpio1_26	General-Purpose Input/Output	IO	P6
gpio1_27	General-Purpose Input/Output	IO	R9
gpio1_28	General-Purpose Input/Output	IO	R5
gpio1_29	General-Purpose Input/Output	IO	P5
gpio1_30	General-Purpose Input/Output	IO	N7
gpio1_31	General-Purpose Input/Output	IO	R4
<b>GPIO 2</b>			
gpio2_0	General-Purpose Input/Output	IO	N9
gpio2_1	General-Purpose Input/Output	IO	P9
gpio2_2	General-Purpose Input/Output	IO	P4
gpio2_3	General-Purpose Input/Output	IO	R3
gpio2_4	General-Purpose Input/Output	IO	T2
gpio2_5	General-Purpose Input/Output	IO	U2
gpio2_6	General-Purpose Input/Output	IO	U1
gpio2_7	General-Purpose Input/Output	IO	P3
gpio2_8	General-Purpose Input/Output	IO	R2
gpio2_9	General-Purpose Input/Output	IO	K7
gpio2_10	General-Purpose Input/Output	IO	M7
gpio2_11	General-Purpose Input/Output	IO	J5
gpio2_12	General-Purpose Input/Output	IO	K6
gpio2_13	General-Purpose Input/Output	IO	J7
gpio2_14	General-Purpose Input/Output	IO	J4
gpio2_15	General-Purpose Input/Output	IO	J6
gpio2_16	General-Purpose Input/Output	IO	H4
gpio2_17	General-Purpose Input/Output	IO	H5
gpio2_18	General-Purpose Input/Output	IO	H6
gpio2_19	General-Purpose Input/Output	IO	T1
gpio2_20	General-Purpose Input/Output	IO	P2
gpio2_21	General-Purpose Input/Output	IO	P1
gpio2_22	General-Purpose Input/Output	IO	P7
gpio2_23	General-Purpose Input/Output	IO	N1
gpio2_24	General-Purpose Input/Output	IO	M5
gpio2_25	General-Purpose Input/Output	IO	M3
gpio2_26	General-Purpose Input/Output	IO	N6
gpio2_27	General-Purpose Input/Output	IO	M4
gpio2_28	General-Purpose Input/Output	IO	N2
gpio2_29	General-Purpose Input/Output	IO	B17
gpio2_30	General-Purpose Input/Output	IO	AG8
gpio2_31	General-Purpose Input/Output	IO	AH7
<b>GPIO 3</b>			
gpio3_0	General-Purpose Input/Output	IO	AD9
gpio3_1	General-Purpose Input/Output	IO	AF9
gpio3_2	General-Purpose Input/Output	IO	AE9

**Table 4-21. GPIOs Signal Descriptions (continued)**

SIGNAL NAME	DESCRIPTION	TYPE	BALL
gpio3_3	General-Purpose Input/Output	IO	AF8
gpio3_4	General-Purpose Input/Output	IO	AE8
gpio3_5	General-Purpose Input/Output	IO	AD8
gpio3_6	General-Purpose Input/Output	IO	AG7
gpio3_7	General-Purpose Input/Output	IO	AH6
gpio3_8	General-Purpose Input/Output	IO	AH3
gpio3_9	General-Purpose Input/Output	IO	AH5
gpio3_10	General-Purpose Input/Output	IO	AG6
gpio3_11	General-Purpose Input/Output	IO	AH4
gpio3_12	General-Purpose Input/Output	IO	AG4
gpio3_13	General-Purpose Input/Output	IO	AG2
gpio3_14	General-Purpose Input/Output	IO	AG3
gpio3_15	General-Purpose Input/Output	IO	AG5
gpio3_16	General-Purpose Input/Output	IO	AF2
gpio3_17	General-Purpose Input/Output	IO	AF6
gpio3_18	General-Purpose Input/Output	IO	AF3
gpio3_19	General-Purpose Input/Output	IO	AF4
gpio3_20	General-Purpose Input/Output	IO	AF1
gpio3_21	General-Purpose Input/Output	IO	AE3
gpio3_22	General-Purpose Input/Output	IO	AE5
gpio3_23	General-Purpose Input/Output	IO	AE1
gpio3_24	General-Purpose Input/Output	IO	AE2
gpio3_25	General-Purpose Input/Output	IO	AE6
gpio3_26	General-Purpose Input/Output	IO	AD2
gpio3_27	General-Purpose Input/Output	IO	AD3
gpio3_28	General-Purpose Input/Output	IO	E1
gpio3_29	General-Purpose Input/Output	IO	G2
gpio3_30	General-Purpose Input/Output	IO	H7
gpio3_31	General-Purpose Input/Output	IO	G1
<b>GPIO 4</b>			
gpio4_0	General-Purpose Input/Output	IO	G6
gpio4_1	General-Purpose Input/Output	IO	F2
gpio4_2	General-Purpose Input/Output	IO	F3
gpio4_3	General-Purpose Input/Output	IO	D1
gpio4_4	General-Purpose Input/Output	IO	E2
gpio4_5	General-Purpose Input/Output	IO	D2
gpio4_6	General-Purpose Input/Output	IO	F4
gpio4_7	General-Purpose Input/Output	IO	C1
gpio4_8	General-Purpose Input/Output	IO	E4
gpio4_9	General-Purpose Input/Output	IO	F5
gpio4_10	General-Purpose Input/Output	IO	E6
gpio4_11	General-Purpose Input/Output	IO	D3
gpio4_12	General-Purpose Input/Output	IO	F6
gpio4_13	General-Purpose Input/Output	IO	D5
gpio4_14	General-Purpose Input/Output	IO	C2
gpio4_15	General-Purpose Input/Output	IO	C3
gpio4_16	General-Purpose Input/Output	IO	C4

**Table 4-21. GPIOs Signal Descriptions (continued)**

SIGNAL NAME	DESCRIPTION	TYPE	BALL
gpio4_17	General-Purpose Input/Output	IO	A12
gpio4_18	General-Purpose Input/Output	IO	E14
gpio4_19	General-Purpose Input/Output	IO	D11
gpio4_20	General-Purpose Input/Output	IO	B10
gpio4_21	General-Purpose Input/Output	IO	B11
gpio4_22	General-Purpose Input/Output	IO	C11
gpio4_23	General-Purpose Input/Output	IO	E11
gpio4_24	General-Purpose Input/Output	IO	B2
gpio4_25	General-Purpose Input/Output	IO	D6
gpio4_26	General-Purpose Input/Output	IO	C5
gpio4_27	General-Purpose Input/Output	IO	A3
gpio4_28	General-Purpose Input/Output	IO	B3
gpio4_29	General-Purpose Input/Output	IO	B4
gpio4_30	General-Purpose Input/Output	IO	B5
gpio4_31	General-Purpose Input/Output	IO	A4
<b>GPIO 5</b>			
gpio5_0	General-Purpose Input/Output	IO	B14
gpio5_1	General-Purpose Input/Output	IO	J14
gpio5_2	General-Purpose Input/Output	IO	G12
gpio5_3	General-Purpose Input/Output	IO	F12
gpio5_4	General-Purpose Input/Output	IO	G13
gpio5_5	General-Purpose Input/Output	IO	J11
gpio5_6	General-Purpose Input/Output	IO	E12
gpio5_7	General-Purpose Input/Output	IO	F13
gpio5_8	General-Purpose Input/Output	IO	C12
gpio5_9	General-Purpose Input/Output	IO	D12
gpio5_10	General-Purpose Input/Output	IO	B12
gpio5_11	General-Purpose Input/Output	IO	A11
gpio5_12	General-Purpose Input/Output	IO	B13
gpio5_13	General-Purpose Input/Output	IO	B18
gpio5_14	General-Purpose Input/Output	IO	F15
gpio5_15	General-Purpose Input/Output	IO	V1
gpio5_16	General-Purpose Input/Output	IO	U4
gpio5_17	General-Purpose Input/Output	IO	U3
gpio5_18	General-Purpose Input/Output	IO	V2
gpio5_19	General-Purpose Input/Output	IO	Y1
gpio5_20	General-Purpose Input/Output	IO	W9
gpio5_21	General-Purpose Input/Output	IO	V9
gpio5_22	General-Purpose Input/Output	IO	V7
gpio5_23	General-Purpose Input/Output	IO	U7
gpio5_24	General-Purpose Input/Output	IO	V6
gpio5_25	General-Purpose Input/Output	IO	U6
gpio5_26	General-Purpose Input/Output	IO	U5
gpio5_27	General-Purpose Input/Output	IO	V5
gpio5_28	General-Purpose Input/Output	IO	V4
gpio5_29	General-Purpose Input/Output	IO	V3
gpio5_30	General-Purpose Input/Output	IO	Y2

**Table 4-21. GPIOs Signal Descriptions (continued)**

SIGNAL NAME	DESCRIPTION	TYPE	BALL
gpio5_31	General-Purpose Input/Output	IO	W2
<b>GPIO 6</b>			
gpio6_4	General-Purpose Input/Output	IO	A13
gpio6_5	General-Purpose Input/Output	IO	G14
gpio6_6	General-Purpose Input/Output	IO	F14
gpio6_7	General-Purpose Input/Output	IO	B16
gpio6_8	General-Purpose Input/Output	IO	C15
gpio6_9	General-Purpose Input/Output	IO	A16
gpio6_10	General-Purpose Input/Output	IO	AC5
gpio6_11	General-Purpose Input/Output	IO	AB4
gpio6_12	General-Purpose Input/Output	IO	AB10
gpio6_13	General-Purpose Input/Output	IO	AC10
gpio6_14	General-Purpose Input/Output	IO	E21
gpio6_15	General-Purpose Input/Output	IO	F20
gpio6_16	General-Purpose Input/Output	IO	F21
gpio6_17	General-Purpose Input/Output	IO	D18
gpio6_18	General-Purpose Input/Output	IO	E17
gpio6_19	General-Purpose Input/Output	IO	B26
gpio6_20	General-Purpose Input/Output	IO	C23
gpio6_21	General-Purpose Input/Output	IO	W6
gpio6_22	General-Purpose Input/Output	IO	Y6
gpio6_23	General-Purpose Input/Output	IO	AA6
gpio6_24	General-Purpose Input/Output	IO	Y4
gpio6_25	General-Purpose Input/Output	IO	AA5
gpio6_26	General-Purpose Input/Output	IO	Y3
gpio6_27	General-Purpose Input/Output	IO	W7
gpio6_28	General-Purpose Input/Output	IO	Y9
gpio6_29	General-Purpose Input/Output	IO	AD4
gpio6_30	General-Purpose Input/Output	IO	AC4
gpio6_31	General-Purpose Input/Output	IO	AC7
<b>GPIO 7</b>			
gpio7_0	General-Purpose Input/Output	IO	AC6
gpio7_1	General-Purpose Input/Output	IO	AC9
gpio7_2	General-Purpose Input/Output	IO	AC3
gpio7_3	General-Purpose Input/Output	IO	R6
gpio7_4	General-Purpose Input/Output	IO	T9
gpio7_5	General-Purpose Input/Output	IO	T6
gpio7_6	General-Purpose Input/Output	IO	T7
gpio7_7	General-Purpose Input/Output	IO	A25
gpio7_8	General-Purpose Input/Output	IO	F16
gpio7_9	General-Purpose Input/Output	IO	B25
gpio7_10	General-Purpose Input/Output	IO	A24
gpio7_11	General-Purpose Input/Output	IO	A22
gpio7_12	General-Purpose Input/Output	IO	B21
gpio7_13	General-Purpose Input/Output	IO	B20
gpio7_14	General-Purpose Input/Output	IO	A26
gpio7_15	General-Purpose Input/Output	IO	B22

**Table 4-21. GPIOs Signal Descriptions (continued)**

SIGNAL NAME	DESCRIPTION	TYPE	BALL
gpio7_16	General-Purpose Input/Output	IO	G17
gpio7_17	General-Purpose Input/Output	IO	B24
gpio7_18	General-Purpose Input/Output	IO	L1
gpio7_19	General-Purpose Input/Output	IO	K2
gpio7_22	General-Purpose Input/Output	IO	B27
gpio7_23	General-Purpose Input/Output	IO	C26
gpio7_24	General-Purpose Input/Output	IO	E25
gpio7_25	General-Purpose Input/Output	IO	C27
gpio7_26	General-Purpose Input/Output	IO	D28
gpio7_27	General-Purpose Input/Output	IO	D26
gpio7_28	General-Purpose Input/Output	IO	J1
gpio7_29	General-Purpose Input/Output	IO	J2
gpio7_30	General-Purpose Input/Output	IO	D14
gpio7_31	General-Purpose Input/Output	IO	C14
<b>GPIO 8</b>			
gpio8_0	General-Purpose Input/Output	IO	F11
gpio8_1	General-Purpose Input/Output	IO	G10
gpio8_2	General-Purpose Input/Output	IO	F10
gpio8_3	General-Purpose Input/Output	IO	G11
gpio8_4	General-Purpose Input/Output	IO	E9
gpio8_5	General-Purpose Input/Output	IO	F9
gpio8_6	General-Purpose Input/Output	IO	F8
gpio8_7	General-Purpose Input/Output	IO	E7
gpio8_8	General-Purpose Input/Output	IO	E8
gpio8_9	General-Purpose Input/Output	IO	D9
gpio8_10	General-Purpose Input/Output	IO	D7
gpio8_11	General-Purpose Input/Output	IO	D8
gpio8_12	General-Purpose Input/Output	IO	A5
gpio8_13	General-Purpose Input/Output	IO	C6
gpio8_14	General-Purpose Input/Output	IO	C8
gpio8_15	General-Purpose Input/Output	IO	C7
gpio8_16	General-Purpose Input/Output	IO	B7
gpio8_17	General-Purpose Input/Output	IO	B8
gpio8_18	General-Purpose Input/Output	IO	A7
gpio8_19	General-Purpose Input/Output	IO	A8
gpio8_20	General-Purpose Input/Output	IO	C9
gpio8_21	General-Purpose Input/Output	IO	A9
gpio8_22	General-Purpose Input/Output	IO	B9
gpio8_23	General-Purpose Input/Output	IO	A10
gpio8_27	General-Purpose Input	I	D23
gpio8_28	General-Purpose Input/Output	IO	F19
gpio8_29	General-Purpose Input/Output	IO	E18
gpio8_30 <sup>(1)</sup>	General-Purpose Input/Output	IO	G21
gpio8_31 <sup>(1)</sup>	General-Purpose Input/Output	IO	D24



- (1) gpio8\_30 is multiplexed with EMU0 and gpio8\_31 is multiplexed with EMU1. These pins will be sampled at reset release by the test and emulation logic. Therefore, if they are used as GPIO pins, they must return to the high state whenever the device enters reset. This can be controlled by logic driven from rstoutn. After the device exits reset (indicated by rstoutn rising), these can return to GPIO mode.

### 4.3.21 KBD

#### NOTE

For more information, see the *Keyboard Controller* section in the device TRM.

**Table 4-22. Keyboard Signal Descriptions**

SIGNAL NAME	DESCRIPTION	TYPE	BALL
kbd_row0	Keypad row 0	I	AD9/ E1
kbd_row1	Keypad row 1	I	AF9/ G2
kbd_row2	Keypad row 2	I	AG4/ G1
kbd_row3	Keypad row 3	I	AG2/ G6
kbd_row4	Keypad row 4	I	AG3/ F2
kbd_row5	Keypad row 5	I	AG5/ F3
kbd_row6	Keypad row 6	I	AF2/ D1
kbd_row7	Keypad row 7	I	AF6/ F6
kbd_row8	Keypad row 8	I	AF3/ C2
kbd_col0	Keypad column 0	O	AF4/ E2
kbd_col1	Keypad column 1	O	AF1/ D2
kbd_col2	Keypad column 2	O	AE3/ F4
kbd_col3	Keypad column 3	O	AE5/ C1
kbd_col4	Keypad column 4	O	AE1/ E4
kbd_col5	Keypad column 5	O	AE2/ F5
kbd_col6	Keypad column 6	O	AE6/ E6
kbd_col7	Keypad column 7	O	AD2/ D3
kbd_col8	Keypad column 8	O	AD3/ D5

### 4.3.22 PWM

#### NOTE

For more information, see the *Pulse-Width Modulation (PWM) subsystem* section in the device TRM.

**Table 4-23. PWM Signal Descriptions**

SIGNAL NAME	DESCRIPTION	TYPE	BALL
<b>PWMSS1</b>			
eQEP1A_in	EQEP1 Quadrature Input A	I	E1/ AD9
eQEP1B_in	EQEP1 Quadrature Input B	I	G2/ AF9
eQEP1_index	EQEP1 Index Input	IO	AE9/ H7
eQEP1_strobe	EQEP1 Strobe Input	IO	G1/ AF8
ehrpwm1A	EHRPWM1 Output A	O	AE8/ G6
ehrpwm1B	EHRPWM1 Output B	O	AD8/ F2
ehrpwm1_tripzone_in put	EHRPWM1 Trip Zone Input	IO	AG7/ F3
eCAP1_in_PWM1_out	ECAP1 Capture Input / PWM Output	IO	AH6/ D1
ehrpwm1_synci	EHRPWM1 Sync Input	I	AH3/ E2

**Table 4-23. PWM Signal Descriptions (continued)**

SIGNAL NAME	DESCRIPTION	TYPE	BALL
ehrpwm1_synco	EHRPWM1 Sync Output	O	AH5/ D2
<b>PWMSS2</b>			
eQEP2A_in	EQEP2 Quadrature Input A	I	AG6/ F4
eQEP2B_in	EQEP2 Quadrature Input B	I	AH4/ C1
eQEP2_index	EQEP2 Index Input	IO	AG4/ E4
eQEP2_strobe	EQEP2 Strobe Input	IO	AG2/ F5
ehrpwm2A	EHRPWM2 Output A	O	AC5/ E6
ehrpwm2B	EHRPWM2 Output B	O	AB4/ D3
ehrpwm2_tripzone_in put	EHRPWM2 Trip Zone Input	IO	AD4/ F6
eCAP2_in_PWM2_out	ECAP2 Capture Input / PWM Output	IO	AC4/ D5
<b>PWMSS3</b>			
eQEP3A_in	EQEP3 Quadrature Input A	I	AC7/ C2
eQEP3B_in	EQEP3 Quadrature Input B	I	AC6/ C3
eQEP3_index	EQEP3 Index Input	IO	AC9/ C4
eQEP3_strobe	EQEP3 Strobe Input	IO	AC3/ B2
ehrpwm3A	EHRPWM3 Output A	O	AC8/ D6
ehrpwm3B	EHRPWM3 Output B	O	AD6/ C5
ehrpwm3_tripzone_in put	EHRPWM3 Trip Zone Input	IO	AB8/ A3
eCAP3_in_PWM3_out	ECAP3 Capture Input / PWM Output	IO	AB5/ B3

**4.3.23 PRU-ICSS****CAUTION**

The I/O timings provided in [Section 5.10, Timing Requirements and Switching Characteristics](#) are valid only if signals within a single IOSET are used. The IOSETs are defined in the [Table 5-188](#) and [Table 5-189](#).

**NOTE**

For more information, see the *Programmable Real-Time Unit Subsystem and Industrial Communication Subsystem* section in the device TRM.

**Table 4-24. PRU-ICSS Signal Descriptions**

SIGNAL NAME	DESCRIPTION	TYPE	BALL BOTTOM
<b>PRU-ICSS 1</b>			
pr1_pru0_gpo0	PRU0 General-Purpose Output	O	AH6
pr1_pru0_gpo1	PRU0 General-Purpose Output	O	AH3
pr1_pru0_gpo2	PRU0 General-Purpose Output	O	AH5
pr1_pru0_gpo3	PRU0 General-Purpose Output	O	AG6
pr1_pru0_gpo4	PRU0 General-Purpose Output	O	AH4
pr1_pru0_gpo5	PRU0 General-Purpose Output	O	AG4
pr1_pru0_gpo6	PRU0 General-Purpose Output	O	AG2
pr1_pru0_gpo7	PRU0 General-Purpose Output	O	AG3
pr1_pru0_gpo8	PRU0 General-Purpose Output	O	AG5

**Table 4-24. PRU-ICSS Signal Descriptions (continued)**

SIGNAL NAME	DESCRIPTION	TYPE	BALL BOTTOM
pr1_pru0_gpo9	PRU0 General-Purpose Output	O	AF2
pr1_pru0_gpo10	PRU0 General-Purpose Output	O	AF6
pr1_pru0_gpo11	PRU0 General-Purpose Output	O	AF3
pr1_pru0_gpo12	PRU0 General-Purpose Output	O	AF4
pr1_pru0_gpo13	PRU0 General-Purpose Output	O	AF1
pr1_pru0_gpo14	PRU0 General-Purpose Output	O	AE3
pr1_pru0_gpo15	PRU0 General-Purpose Output	O	AE5
pr1_pru0_gpo16	PRU0 General-Purpose Output	O	AE1
pr1_pru0_gpo17	PRU0 General-Purpose Output	O	AE2
pr1_pru0_gpo18	PRU0 General-Purpose Output	O	AE6
pr1_pru0_gpo19	PRU0 General-Purpose Output	O	AD2
pr1_pru0_gpo20	PRU0 General-Purpose Output	O	AD3
pr1_pru0_gpi0	PRU0 General-Purpose Input	I	AH6
pr1_pru0_gpi1	PRU0 General-Purpose Input	I	AH3
pr1_pru0_gpi2	PRU0 General-Purpose Input	I	AH5
pr1_pru0_gpi3	PRU0 General-Purpose Input	I	AG6
pr1_pru0_gpi4	PRU0 General-Purpose Input	I	AH4
pr1_pru0_gpi5	PRU0 General-Purpose Input	I	AG4
pr1_pru0_gpi6	PRU0 General-Purpose Input	I	AG2
pr1_pru0_gpi7	PRU0 General-Purpose Input	I	AG3
pr1_pru0_gpi8	PRU0 General-Purpose Input	I	AG5
pr1_pru0_gpi9	PRU0 General-Purpose Input	I	AF2
pr1_pru0_gpi10	PRU0 General-Purpose Input	I	AF6
pr1_pru0_gpi11	PRU0 General-Purpose Input	I	AF3
pr1_pru0_gpi12	PRU0 General-Purpose Input	I	AF4
pr1_pru0_gpi13	PRU0 General-Purpose Input	I	AF1
pr1_pru0_gpi14	PRU0 General-Purpose Input	I	AE3
pr1_pru0_gpi15	PRU0 General-Purpose Input	I	AE5
pr1_pru0_gpi16	PRU0 General-Purpose Input	I	AE1
pr1_pru0_gpi17	PRU0 General-Purpose Input	I	AE2
pr1_pru0_gpi18	PRU0 General-Purpose Input	I	AE6
pr1_pru0_gpi19	PRU0 General-Purpose Input	I	AD2
pr1_pru0_gpi20	PRU0 General-Purpose Input	I	AD3
pr1_pru1_gpo0	PRU1 General-Purpose Output	O	E2
pr1_pru1_gpo1	PRU1 General-Purpose Output	O	D2
pr1_pru1_gpo2	PRU1 General-Purpose Output	O	F4
pr1_pru1_gpo3	PRU1 General-Purpose Output	O	C1
pr1_pru1_gpo4	PRU1 General-Purpose Output	O	E4
pr1_pru1_gpo5	PRU1 General-Purpose Output	O	F5
pr1_pru1_gpo6	PRU1 General-Purpose Output	O	E6
pr1_pru1_gpo7	PRU1 General-Purpose Output	O	D3
pr1_pru1_gpo8	PRU1 General-Purpose Output	O	F6
pr1_pru1_gpo9	PRU1 General-Purpose Output	O	D5
pr1_pru1_gpo10	PRU1 General-Purpose Output	O	C2
pr1_pru1_gpo11	PRU1 General-Purpose Output	O	C3
pr1_pru1_gpo12	PRU1 General-Purpose Output	O	C4
pr1_pru1_gpo13	PRU1 General-Purpose Output	O	B2

**Table 4-24. PRU-ICSS Signal Descriptions (continued)**

SIGNAL NAME	DESCRIPTION	TYPE	BALL BOTTOM
pr1_pru1_gpo14	PRU1 General-Purpose Output	O	D6
pr1_pru1_gpo15	PRU1 General-Purpose Output	O	C5
pr1_pru1_gpo16	PRU1 General-Purpose Output	O	A3
pr1_pru1_gpo17	PRU1 General-Purpose Output	O	B3
pr1_pru1_gpo18	PRU1 General-Purpose Output	O	B4
pr1_pru1_gpo19	PRU1 General-Purpose Output	O	B5
pr1_pru1_gpo20	PRU1 General-Purpose Output	O	A4
pr1_pru1_gpi0	PRU1 General-Purpose Input	I	E2
pr1_pru1_gpi1	PRU1 General-Purpose Input	I	D2
pr1_pru1_gpi2	PRU1 General-Purpose Input	I	F4
pr1_pru1_gpi3	PRU1 General-Purpose Input	I	C1
pr1_pru1_gpi4	PRU1 General-Purpose Input	I	E4
pr1_pru1_gpi5	PRU1 General-Purpose Input	I	F5
pr1_pru1_gpi6	PRU1 General-Purpose Input	I	E6
pr1_pru1_gpi7	PRU1 General-Purpose Input	I	D3
pr1_pru1_gpi8	PRU1 General-Purpose Input	I	F6
pr1_pru1_gpi9	PRU1 General-Purpose Input	I	D5
pr1_pru1_gpi10	PRU1 General-Purpose Input	I	C2
pr1_pru1_gpi11	PRU1 General-Purpose Input	I	C3
pr1_pru1_gpi12	PRU1 General-Purpose Input	I	C4
pr1_pru1_gpi13	PRU1 General-Purpose Input	I	B2
pr1_pru1_gpi14	PRU1 General-Purpose Input	I	D6
pr1_pru1_gpi15	PRU1 General-Purpose Input	I	C5
pr1_pru1_gpi16	PRU1 General-Purpose Input	I	A3
pr1_pru1_gpi17	PRU1 General-Purpose Input	I	B3
pr1_pru1_gpi18	PRU1 General-Purpose Input	I	B4
pr1_pru1_gpi19	PRU1 General-Purpose Input	I	B5
pr1_pru1_gpi20	PRU1 General-Purpose Input	I	A4
pr1_mii_mt0_clk	MII0 Transmit Clock	I	U5
pr1_mii0_txen	MII0 Transmit Enable	O	V3
pr1_mii0_txd3	MII0 Transmit Data	O	V5
pr1_mii0_txd2	MII0 Transmit Data	O	V4
pr1_mii0_txd1	MII0 Transmit Data	O	Y2
pr1_mii0_txd0	MII0 Transmit Data	O	W2
pr1_mii0_rxdv	MII0 Data Valid	I	V2
pr1_mii_mr0_clk	MII0 Receive Clock	I	Y1
pr1_mii0_rxd3	MII0 Receive Data	I	W9
pr1_mii0_rxd2	MII0 Receive Data	I	V9
pr1_mii0_crs	MII0 Carrier Sense	I	V7
pr1_mii0_rxer	MII0 Receive Error	I	U7
pr1_mii0_rxd1	MII0 Receive Data	I	V6
pr1_mii0_rxd0	MII0 Receive Data	I	U6
pr1_mii0_col	MII0 Collision Detect	I	V1
pr1_mii0_rxlk	MII0 Receive Link	I	U4
pr1_mii_mt1_clk	MII1 Transmit Clock	I	C1
pr1_mii1_txen	MII1 Transmit Enable	O	E4
pr1_mii1_txd3	MII1 Transmit Data	O	F5

**Table 4-24. PRU-ICSS Signal Descriptions (continued)**

SIGNAL NAME	DESCRIPTION	TYPE	BALL BOTTOM
pr1_mii1_txd2	MII1 Transmit Data	O	E6
pr1_mii1_txd1	MII1 Transmit Data	O	D5
pr1_mii1_txd0	MII1 Transmit Data	O	C2
pr1_mii_mr1_clk	MII1 Receive Clock	I	C3
pr1_mii1_rxdv	MII1 Data Valid	I	C4
pr1_mii1_rxd3	MII1 Receive Data	I	B2
pr1_mii1_rxd2	MII1 Receive Data	I	D6
pr1_mii1_rxd1	MII1 Receive Data	I	C5
pr1_mii1_rxd0	MII1 Receive Data	I	A3
pr1_mii1_rxer	MII1 Receive Error	I	B3
pr1_mii1_rxlink	MII1 Receive Link	I	B4
pr1_mii1_col	MII1 Collision Detect	I	B5
pr1_mii1_crs	MII1 Carrier Sense	I	A4
pr1_mdio_mdclk	MDIO Clock	O	D3
pr1_mdio_data	MDIO Data	IO	F6
pr1_edc_latch0_in	Latch Input 0	I	AG3 / E2
pr1_edc_latch1_in	Latch Input 1	I	AG5
pr1_edc_sync0_out	SYNC 0 Output	O	AF2 / D2
pr1_edc_sync1_out	SYNC 1 Output	O	AF6
pr1_edio_latch_in	Latch Input	I	AF3
pr1_edio_sof	Start Of Frame	O	AF4 / F4
pr1_edio_data_in0	Ethernet Digital Input	I	AF1 / E1
pr1_edio_data_in1	Ethernet Digital Input	I	AE3 / G2
pr1_edio_data_in2	Ethernet Digital Input	I	AE5 / H7
pr1_edio_data_in3	Ethernet Digital Input	I	AE1 / G1
pr1_edio_data_in4	Ethernet Digital Input	I	AE2 / G6
pr1_edio_data_in5	Ethernet Digital Input	I	AE6 / F2
pr1_edio_data_in6	Ethernet Digital Input	I	AD2 / F3
pr1_edio_data_in7	Ethernet Digital Input	I	AD3 / D1
pr1_edio_data_out0	Ethernet Digital Output	O	AF1 / E1
pr1_edio_data_out1	Ethernet Digital Output	O	AE3 / G2
pr1_edio_data_out2	Ethernet Digital Output	O	AE5 / H7
pr1_edio_data_out3	Ethernet Digital Output	O	AE1 / G1
pr1_edio_data_out4	Ethernet Digital Output	O	AE2 / G6
pr1_edio_data_out5	Ethernet Digital Output	O	AE6 / F2
pr1_edio_data_out6	Ethernet Digital Output	O	AD2 / F3
pr1_edio_data_out7	Ethernet Digital Output	O	AD3 / D1
pr1_uart0_cts_n	UART Clear to Send	I	G1 / F11
pr1_uart0_rts_n	UART Ready to Send	O	G6 / G10
pr1_uart0_rxd	UART Receive Data	I	F2 / F10
pr1_uart0_txd	UART Transmit Data	O	F3 / G11
pr1_ecap0_ecap_capin_apwm_o	Capture Input / PWM output	IO	D1 / E9
<b>PRU-ICSS 2</b>			
pr2_pru0_gpo0	PRU0 General-Purpose Output	O	G11 / AC5
pr2_pru0_gpo1	PRU0 General-Purpose Output	O	E9 / AB4
pr2_pru0_gpo2	PRU0 General-Purpose Output	O	F9 / AD4
pr2_pru0_gpo3	PRU0 General-Purpose Output	O	F8 / AC4

**Table 4-24. PRU-ICSS Signal Descriptions (continued)**

SIGNAL NAME	DESCRIPTION	TYPE	BALL BOTTOM
pr2_pru0_gpo4	PRU0 General-Purpose Output	O	E7 / AC7
pr2_pru0_gpo5	PRU0 General-Purpose Output	O	E8 / AC6
pr2_pru0_gpo6	PRU0 General-Purpose Output	O	D9 / AC9
pr2_pru0_gpo7	PRU0 General-Purpose Output	O	D7 / AC3
pr2_pru0_gpo8	PRU0 General-Purpose Output	O	D8 / AC8
pr2_pru0_gpo9	PRU0 General-Purpose Output	O	A5 / AD6
pr2_pru0_gpo10	PRU0 General-Purpose Output	O	C6 / AB8
pr2_pru0_gpo11	PRU0 General-Purpose Output	O	C8 / AB5
pr2_pru0_gpo12	PRU0 General-Purpose Output	O	C7 / B18
pr2_pru0_gpo13	PRU0 General-Purpose Output	O	B7 / F15
pr2_pru0_gpo14	PRU0 General-Purpose Output	O	B8 / B19
pr2_pru0_gpo15	PRU0 General-Purpose Output	O	A7 / C17
pr2_pru0_gpo16	PRU0 General-Purpose Output	O	A8 / C15
pr2_pru0_gpo17	PRU0 General-Purpose Output	O	C9 / A16
pr2_pru0_gpo18	PRU0 General-Purpose Output	O	A9 / A19
pr2_pru0_gpo19	PRU0 General-Purpose Output	O	B9 / A18
pr2_pru0_gpo20	PRU0 General-Purpose Output	O	A10 / F14
pr2_pru0_gpi0	PRU0 General-Purpose Input	I	G11 / AC5
pr2_pru0_gpi1	PRU0 General-Purpose Input	I	E9 / AB4
pr2_pru0_gpi2	PRU0 General-Purpose Input	I	F9 / AD4
pr2_pru0_gpi3	PRU0 General-Purpose Input	I	F8 / AC4
pr2_pru0_gpi4	PRU0 General-Purpose Input	I	E7 / AC7
pr2_pru0_gpi5	PRU0 General-Purpose Input	I	E8 / AC6
pr2_pru0_gpi6	PRU0 General-Purpose Input	I	D9 / AC9
pr2_pru0_gpi7	PRU0 General-Purpose Input	I	D7 / AC3
pr2_pru0_gpi8	PRU0 General-Purpose Input	I	D8 / AC8
pr2_pru0_gpi9	PRU0 General-Purpose Input	I	A5 / AD6
pr2_pru0_gpi10	PRU0 General-Purpose Input	I	C6 / AB8
pr2_pru0_gpi11	PRU0 General-Purpose Input	I	C8 / AB5
pr2_pru0_gpi12	PRU0 General-Purpose Input	I	C7 / B18
pr2_pru0_gpi13	PRU0 General-Purpose Input	I	B7 / F15
pr2_pru0_gpi14	PRU0 General-Purpose Input	I	B8 / B19
pr2_pru0_gpi15	PRU0 General-Purpose Input	I	A7 / C17
pr2_pru0_gpi16	PRU0 General-Purpose Input	I	A8 / C15
pr2_pru0_gpi17	PRU0 General-Purpose Input	I	C9 / A16
pr2_pru0_gpi18	PRU0 General-Purpose Input	I	A9 / A19
pr2_pru0_gpi19	PRU0 General-Purpose Input	I	B9 / A18
pr2_pru0_gpi20	PRU0 General-Purpose Input	I	A10 / F14
pr2_pru1_gpo0	PRU1 General-Purpose Output	O	V1 / D17
pr2_pru1_gpo1	PRU1 General-Purpose Output	O	U4 / AA3
pr2_pru1_gpo2	PRU1 General-Purpose Output	O	U3 / AB9
pr2_pru1_gpo3	PRU1 General-Purpose Output	O	V2 / AB3
pr2_pru1_gpo4	PRU1 General-Purpose Output	O	Y1 / AA4
pr2_pru1_gpo5	PRU1 General-Purpose Output	O	W9 / D18
pr2_pru1_gpo6	PRU1 General-Purpose Output	O	V9 / E17
pr2_pru1_gpo7	PRU1 General-Purpose Output	O	V7 / C14
pr2_pru1_gpo8	PRU1 General-Purpose Output	O	U7 / G12

**Table 4-24. PRU-ICSS Signal Descriptions (continued)**

SIGNAL NAME	DESCRIPTION	TYPE	BALL BOTTOM
pr2_pru1_gpo9	PRU1 General-Purpose Output	O	V6 / F12
pr2_pru1_gpo10	PRU1 General-Purpose Output	O	U6 / B12
pr2_pru1_gpo11	PRU1 General-Purpose Output	O	U5 / A11
pr2_pru1_gpo12	PRU1 General-Purpose Output	O	V5 / B13
pr2_pru1_gpo13	PRU1 General-Purpose Output	O	V4 / A12
pr2_pru1_gpo14	PRU1 General-Purpose Output	O	V3 / E14
pr2_pru1_gpo15	PRU1 General-Purpose Output	O	Y2 / A13
pr2_pru1_gpo16	PRU1 General-Purpose Output	O	W2 / G14
pr2_pru1_gpo17	PRU1 General-Purpose Output	O	E11
pr2_pru1_gpo18	PRU1 General-Purpose Output	O	F11
pr2_pru1_gpo19	PRU1 General-Purpose Output	O	G10
pr2_pru1_gpo20	PRU1 General-Purpose Output	O	F10
pr2_pru1_gpi0	PRU1 General-Purpose Input	I	V1 / D17
pr2_pru1_gpi1	PRU1 General-Purpose Input	I	U4 / AA3
pr2_pru1_gpi2	PRU1 General-Purpose Input	I	U3 / AB9
pr2_pru1_gpi3	PRU1 General-Purpose Input	I	V2 / AB3
pr2_pru1_gpi4	PRU1 General-Purpose Input	I	Y1 / AA4
pr2_pru1_gpi5	PRU1 General-Purpose Input	I	W9 / D18
pr2_pru1_gpi6	PRU1 General-Purpose Input	I	V9 / E17
pr2_pru1_gpi7	PRU1 General-Purpose Input	I	V7 / C14
pr2_pru1_gpi8	PRU1 General-Purpose Input	I	U7 / G12
pr2_pru1_gpi9	PRU1 General-Purpose Input	I	V6 / F12
pr2_pru1_gpi10	PRU1 General-Purpose Input	I	U6 / B12
pr2_pru1_gpi11	PRU1 General-Purpose Input	I	U5 / A11
pr2_pru1_gpi12	PRU1 General-Purpose Input	I	V5 / B13
pr2_pru1_gpi13	PRU1 General-Purpose Input	I	V4 / A12
pr2_pru1_gpi14	PRU1 General-Purpose Input	I	V3 / E14
pr2_pru1_gpi15	PRU1 General-Purpose Input	I	Y2 / A13
pr2_pru1_gpi16	PRU1 General-Purpose Input	I	W2 / G14
pr2_pru1_gpi17	PRU1 General-Purpose Input	I	E11
pr2_pru1_gpi18	PRU1 General-Purpose Input	I	F11
pr2_pru1_gpi19	PRU1 General-Purpose Input	I	G10
pr2_pru1_gpi20	PRU1 General-Purpose Input	I	F10
pr2_edc_latch0_in	Latch Input 0	I	F9
pr2_edc_latch1_in	Latch Input 1	I	F8
pr2_edc_sync0_out	SYNC 0 Output	O	E7
pr2_edc_sync1_out	SYNC 1 Output	O	E8
pr2_edio_latch_in	Latch Input	I	D9
pr2_edio_sof	Start Of Frame	O	D7
pr2_uart0_cts_n	UART Clear-To-Send	I	D8
pr2_uart0_rts_n	UART Ready-To-Send	O	A5
pr2_uart0_rxd	UART Receive Data	I	C6
pr2_uart0_txd	UART Transmit Data	O	C8
pr2_ecap0_ecap_capin_apwm_o	Capture Input / PWM output	IO	C7
pr2_edio_data_in0	Ethernet Digital Input	I	B7
pr2_edio_data_in1	Ethernet Digital Input	I	B8
pr2_edio_data_in2	Ethernet Digital Input	I	A7

**Table 4-24. PRU-ICSS Signal Descriptions (continued)**

SIGNAL NAME	DESCRIPTION	TYPE	BALL BOTTOM
pr2_edio_data_in3	Ethernet Digital Input	I	A8
pr2_edio_data_in4	Ethernet Digital Input	I	C9
pr2_edio_data_in5	Ethernet Digital Input	I	A9
pr2_edio_data_in6	Ethernet Digital Input	I	B9
pr2_edio_data_in7	Ethernet Digital Input	I	A10
pr2_edio_data_out0	Ethernet Digital Output	O	B7
pr2_edio_data_out1	Ethernet Digital Output	O	B8
pr2_edio_data_out2	Ethernet Digital Output	O	A7
pr2_edio_data_out3	Ethernet Digital Output	O	A8
pr2_edio_data_out4	Ethernet Digital Output	O	C9
pr2_edio_data_out5	Ethernet Digital Output	O	A9
pr2_edio_data_out6	Ethernet Digital Output	O	B9
pr2_edio_data_out7	Ethernet Digital Output	O	A10
pr2_mii1_col	MII1 Collision Detect	I	D18
pr2_mii1_crs	MII1 Carrier Sense	I	E17
pr2_mdio_mdclk	MDIO Clock	O	C14 / AB3
pr2_mdio_data	MDIO Data	IO	D14 / AA4
pr2_mii0_rxer	MII0 Receive Error	I	G12
pr2_mii_mt0_clk	MII0 Transmit Clock	I	F12
pr2_mii0_txen	MII0 Transmit Enable	O	B12
pr2_mii0_txd3	MII0 Transmit Data	O	A11
pr2_mii0_txd2	MII0 Transmit Data	O	B13
pr2_mii0_txd1	MII0 Transmit Data	O	A12
pr2_mii0_txd0	MII0 Transmit Data	O	E14
pr2_mii_mr0_clk	MII0 Receive Clock	I	A13
pr2_mii0_rxdv	MII0 Data Valid	I	G14
pr2_mii0_rxd3	MII0 Receive Data	I	F14
pr2_mii0_rxd2	MII0 Receive Data	I	A19
pr2_mii0_rxd1	MII0 Receive Data	I	A18
pr2_mii0_rxd0	MII0 Receive Data	I	C15
pr2_mii0_rxlk	MII0 Receive Link	I	A16
pr2_mii0_crs	MII0 Carrier Sense	I	B18
pr2_mii0_col	MII0 Collision Detect	I	F15
pr2_mii1_rxer	MII1 Receive Error	I	B19
pr2_mii1_rxlk	MII1 Receive Link	I	C17
pr2_mii_mt1_clk	MII1 Transmit Clock	I	AC5
pr2_mii1_txen	MII1 Transmit Enable	O	AB4
pr2_mii1_txd3	MII1 Transmit Data	O	AD4
pr2_mii1_txd2	MII1 Transmit Data	O	AC4
pr2_mii1_txd1	MII1 Transmit Data	O	AC7
pr2_mii1_txd0	MII1 Transmit Data	O	AC6
pr2_mii_mr1_clk	MII1 Receive Clock	I	AC9
pr2_mii1_rxdv	MII1 Data Valid	I	AC3
pr2_mii1_rxd3	MII1 Receive Data	I	AC8
pr2_mii1_rxd2	MII1 Receive Data	I	AD6
pr2_mii1_rxd1	MII1 Receive Data	I	AB8
pr2_mii1_rxd0	MII1 Receive Data	I	AB5



**NOTE**

PRU-ICSS has internal multiplexing capability of pin functions. See *PRU-ICSS Internal Pinmux* in the device TRM. Besides, EGPIO module can be configured to export additional functions to EGPIO pins in place of simple GPIO. See *Enhanced General-Purpose Module/Serial Capture Unit* in the device TRM.

**4.3.24 Test Interfaces**
**CAUTION**

The I/O timings provided in [Section 5.10, Timing Requirements and Switching Characteristics](#) are valid only if signals within a single IOSET are used. The IOSETs are defined in the [Table 5-215](#).

**NOTE**

For more information, see the *On-Chip Debug Support / Debug Interfaces* section in the device TRM.

**Table 4-25. Debug Signal Descriptions**

SIGNAL NAME	DESCRIPTION	TYPE	BALL
tms	JTAG test port mode select. An external pullup resistor should be used on this ball.	IO	F18
tdi	JTAG test data	I	D23
tdo	JTAG test port data	O	F19
tclk	JTAG test clock	I	E20
trstn	JTAG test reset	I	D20
rtck	JTAG return clock	O	E18
emu0 <sup>(1)</sup>	Emulator pin 0	IO	G21
emu1 <sup>(1)</sup>	Emulator pin 1	IO	D24
emu2	Emulator pin 2	O	F10
emu3	Emulator pin 3	O	D7
emu4	Emulator pin 4	O	A7
emu5	Emulator pin 5	O	E1 / G11
emu6	Emulator pin 6	O	G2 / E9
emu7	Emulator pin 7	O	H7 / F9
emu8	Emulator pin 8	O	G1 / F8
emu9	Emulator pin 9	O	G6 / E7
emu10	Emulator pin 10	O	F2 / D8
emu11	Emulator pin 11	O	F3 / A5
emu12	Emulator pin 12	O	D1 / C6
emu13	Emulator pin 13	O	E2 / C8
emu14	Emulator pin 14	O	D2 / C7
emu15	Emulator pin 15	O	F4 / A8
emu16	Emulator pin 16	O	C1 / C9
emu17	Emulator pin 17	O	E4 / A9
emu18	Emulator pin 18	O	F5 / B9
emu19	Emulator pin 19	O	E6 / A10

- (1) EMU0 and EMU1 are multiplexed with GPIO. These pins will be sampled at reset release by the test and emulation logic. Therefore, if they are used as GPIO pins, they must return to the high state whenever the device enters reset. This can be controlled by logic driven from rstoutn. After the device exits reset (indicated by rstoutn rising), these can return to GPIO mode.

### 4.3.25 System and Miscellaneous

#### 4.3.25.1 Sysboot

---

**NOTE**

For more information, see the *Initialization (ROM Code)* section in the device TRM.

---

**Table 4-26. Sysboot Signal Descriptions**

SIGNAL NAME	DESCRIPTION	TYPE	BALL
sysboot0	Boot Mode Configuration 0. The value latched on this pin upon porz reset release will determine the boot mode configuration of the device.	I	M6
sysboot1	Boot Mode Configuration 1. The value latched on this pin upon porz reset release will determine the boot mode configuration of the device.	I	M2
sysboot2	Boot Mode Configuration 2. The value latched on this pin upon porz reset release will determine the boot mode configuration of the device.	I	L5
sysboot3	Boot Mode Configuration 3. The value latched on this pin upon porz reset release will determine the boot mode configuration of the device.	I	M1
sysboot4	Boot Mode Configuration 4. The value latched on this pin upon porz reset release will determine the boot mode configuration of the device.	I	L6
sysboot5	Boot Mode Configuration 5. The value latched on this pin upon porz reset release will determine the boot mode configuration of the device.	I	L4
sysboot6	Boot Mode Configuration 6. The value latched on this pin upon porz reset release will determine the boot mode configuration of the device.	I	L3
sysboot7	Boot Mode Configuration 7. The value latched on this pin upon porz reset release will determine the boot mode configuration of the device.	I	L2
sysboot8	Boot Mode Configuration 8. The value latched on this pin upon porz reset release will determine the boot mode configuration of the device.	I	L1
sysboot9	Boot Mode Configuration 9. The value latched on this pin upon porz reset release will determine the boot mode configuration of the device.	I	K2
sysboot10	Boot Mode Configuration 10. The value latched on this pin upon porz reset release will determine the boot mode configuration of the device.	I	J1
sysboot11	Boot Mode Configuration 11. The value latched on this pin upon porz reset release will determine the boot mode configuration of the device.	I	J2
sysboot12	Boot Mode Configuration 12. The value latched on this pin upon porz reset release will determine the boot mode configuration of the device.	I	H1
sysboot13	Boot Mode Configuration 13. The value latched on this pin upon porz reset release will determine the boot mode configuration of the device.	I	J3
sysboot14	Boot Mode Configuration 14. The value latched on this pin upon porz reset release will determine the boot mode configuration of the device.	I	H2
sysboot15	Boot Mode Configuration 15. The value latched on this pin upon porz reset release will determine the boot mode configuration of the device.	I	H3

#### 4.3.25.2 PRCM

---

**NOTE**

For more information, see the *PRCM* chapter in the device TRM.

---

**Table 4-27. PRCM Signal Descriptions**

SIGNAL NAME	DESCRIPTION	TYPE	BALL
clkout1	Device Clock output 1. Can be used externally for devices with non-critical timing requirements, or for debug, or as a reference clock on GPMC as described in <a href="#">Table 5-57, GPMC/NOR Flash Interface Switching Characteristics - Synchronous Mode - Default</a> and <a href="#">Table 5-59, GPMC/NOR Flash Interface Switching Characteristics - Synchronous Mode - Alternate</a> .	O	F21 / P7

**Table 4-27. PRCM Signal Descriptions (continued)**

SIGNAL NAME	DESCRIPTION	TYPE	BALL
clkout2	Device Clock output 2. Can be used externally for devices with noncritical timing requirements, or for debug.	O	D18 / N1
clkout3	Device Clock output 3. Can be used externally for devices with noncritical timing requirements, or for debug.	O	C23
rstoutn	Reset out (Active low). This pin asserts low in response to any global reset condition on the device. <sup>(2)</sup>	O	F23
resetn	Device Reset Input	I	E23
porz	Power-on Reset (active low). This pin must be asserted low until all device supplies are valid (see reset sequence/requirements)	I	F22
xref_clk0	External Reference Clock 0. For Audio and other Peripherals.	I	D18
xref_clk1	External Reference Clock 1. For Audio and other Peripherals.	I	E17
xref_clk2	External Reference Clock 2. For Audio and other Peripherals.	I	B26
xref_clk3	External Reference Clock 3. For Audio and other Peripherals.	I	C23
xi_osc0	System Oscillator OSC0 Crystal input / LVCMOS clock input. Functions as the input connection to a crystal when the internal oscillator OSC0 is used. Functions as an LVCMOS-compatible input clock when an external oscillator is used.	I	AE15
xo_osc0	System Oscillator OSC0 Crystal output	O	AD15
xi_osc1	Auxiliary Oscillator OSC1 Crystal input / LVCMOS clock input. Functions as the input connection to a crystal when the internal oscillator OSC1 is used. Functions as an LVCMOS-compatible input clock when an external oscillator is used	I	AC15
xo_osc1	Auxiliary Oscillator OSC1 Crystal output	O	AC13
RMII_MHZ_50_CLK <sup>(1)</sup>	RMII Reference Clock (50 MHz). This pin is an input when external reference is used or output when internal reference is used.	IO	U3

- (1) This clock signal is implemented as 'pad loopback' inside the device - the output signal is looped back through the input buffer to serve as the internal reference signal. Series termination is recommended (as close to device pin as possible) to improve signal integrity of the clock input. Any nonmonotonicity in voltage that occurs at the pad loopback clock pin between  $V_{IH}$  and  $V_{IL}$  must be less than  $V_{HYS}$ .
- (2) Note that rstoutn is only valid after vddshv3 is valid. If the rstoutn signal will be used as a reset into other devices attached to the SoC, it must be AND'ed with porz. This will prevent glitches occurring during supply ramping being propagated.

### 4.3.25.3 RTCSS

---

#### NOTE

For more information, see the *Real-Time Clock (RTC)* chapter in the device TRM.

---

#### NOTE

RTC-only mode is not a supported feature.

---

**Table 4-28. RTC Signal Descriptions**

SIGNAL NAME	DESCRIPTION	TYPE	BALL
Wakeup0	RTC External Wakeup Input 0	I	AD17
Wakeup1	RTC External Wakeup Input 1	I	AC17
Wakeup2	RTC External Wakeup Input 2	I	AB16
Wakeup3	RTC External Wakeup Input 3	I	AC16
rtc_porz	RTC Power Domain Power-On Reset Input	I	AB17
rtc_osc_xi_clkin32	RTC Oscillator Input. Crystal connection to internal RTC oscillator. Functions as an RTC clock input when an external oscillator is used.	I	AE14
rtc_osc_xo	RTC Oscillator Output	O	AD14
rtc_iso <sup>(1)</sup>	RTC Domain Isolation Signal	I	AF14
on_off	RTC Power Enable output pin	O	Y11

- (1) This signal must be kept 0 if device power supplies are not valid during RTC mode and 1 during normal operation. This can typically be achieved by connecting `rtc_iso` to the same signal driving `porz` (not `rtc_porz`) with appropriate voltage level translation if necessary.

#### 4.3.25.4 SDMA

**NOTE**

For more information, see the *DMA Controllers / System DMA* section in the device TRM.

**Table 4-29. System DMA Signal Descriptions**

SIGNAL NAME	DESCRIPTION	TYPE	BALL
<code>dma_evt1</code>	System DMA Event Input 1	I	P7 / P4
<code>dma_evt2</code>	System DMA Event Input 2	I	N1 / R3
<code>dma_evt3</code>	System DMA Event Input 3	I	N6
<code>dma_evt4</code>	System DMA Event Input 4	I	M4

#### 4.3.25.5 INTC

**NOTE**

For more information, see the *Interrupt Controllers* chapter in the device TRM.

**Table 4-30. INTC Signal Descriptions**

SIGNAL NAME	DESCRIPTION	TYPE	BALL
<code>nmin_dsp</code>	Non-maskable interrupt input, active-low. This pin can be optionally routed to the DSP NMI input or as generic input to the Arm cores. Note that by default this pin has an internal pulldown resistor enabled. This internal pulldown should be disabled or countered by a stronger external pullup resistor before routing to the DSP or Arm processors.	I	D21
<code>sys_nirq2</code>	External interrupt event to any device INTC	I	AB16
<code>sys_nirq1</code>	External interrupt event to any device INTC	I	AC16

#### 4.3.25.6 Observability

**NOTE**

For more information, see the *Control Module* chapter in the device TRM.

**Table 4-31. Observability Signal Descriptions**

SIGNAL NAME	DESCRIPTION	TYPE	BALL
<code>obs0</code>	Observation Output 0	O	F10
<code>obs1</code>	Observation Output 1	O	G11
<code>obs2</code>	Observation Output 2	O	E9
<code>obs3</code>	Observation Output 3	O	F9
<code>obs4</code>	Observation Output 4	O	F8
<code>obs5</code>	Observation Output 5	O	D7
<code>obs6</code>	Observation Output 6	O	D8
<code>obs7</code>	Observation Output 7	O	A5
<code>obs8</code>	Observation Output 8	O	C6
<code>obs9</code>	Observation Output 9	O	C8
<code>obs10</code>	Observation Output 10	O	C7
<code>obs11</code>	Observation Output 11	O	A7

**Table 4-31. Observability Signal Descriptions (continued)**

SIGNAL NAME	DESCRIPTION	TYPE	BALL
obs12	Observation Output 12	O	A8
obs13	Observation Output 13	O	C9
obs14	Observation Output 14	O	A9
obs15	Observation Output 15	O	B9
obs16	Observation Output 16	O	F10
obs17	Observation Output 17	O	G11
obs18	Observation Output 18	O	E9
obs19	Observation Output 19	O	F9
obs20	Observation Output 20	O	F8
obs21	Observation Output 21	O	D7
obs22	Observation Output 22	O	D8
obs23	Observation Output 23	O	A5
obs24	Observation Output 24	O	C6
obs25	Observation Output 25	O	C8
obs26	Observation Output 26	O	C7
obs27	Observation Output 27	O	A7
obs28	Observation Output 28	O	A8
obs29	Observation Output 29	O	C9
obs30	Observation Output 30	O	A9
obs31	Observation Output 31	O	B9
obs_dmarq1	DMA Request External Observation Output 1	O	G11
obs_dmarq2	DMA Request External Observation Output 2	O	D8
obs_irq1	IRQ External Observation Output 1	O	F10
obs_irq2	IRQ External Observation Output 2	O	D7

**4.3.25.7 Power Supplies****NOTE**

For more information, see the *Power, Reset, and Clock Management / PRCM Subsystem Environment / External Voltage Inputs* section in the device TRM.

**Table 4-32. Power Supply Signal Descriptions**

SIGNAL NAME	DESCRIPTION	TYPE	BALL
vdd	Core voltage domain supply	PWR	H13/ H14/ J17/ J18/ L7/ L8/ N10/ N13/ P11/ P12/ P13/ R11/ R16/ R19/ T13/ T16/ T19/ U8/ U9/ U13/ U16/ V8/ V16
vpp <sup>(2)</sup>	eFuse power supply	PWR	K14

**Table 4-32. Power Supply Signal Descriptions (continued)**

SIGNAL NAME	DESCRIPTION	TYPE	BALL
vss	Ground	GND	A1/ A2/ A6/ A14/ A23/ A28/ B1/ D13/ D19/ E13/ E19/ F1/ F7/ G7/ G8/ G9/ H12/ J12/ J15/ J28/ K1/ K4/ K5/ K15/ K24/ K25/ L13/ L14/ M19/ N14/ N15/ N19/ N24/ N25/ P28/ R1/ R12/ R13/ R15/ R21/ T10/ T11/ T12/ T14/ T15/ T17/ T18/ T21/ U15/ U17/ U20/ U21/ V15/ V17/ W1/ W15/ W24/ W25/ W28/ AA8/ AA9/ AA10/ AA14/ AA15/ AA20/ AB14/ AB20/ AD1/ AD24/ AG1/ AH1/ AH2/ AH8/ AH20/ AH28 / AB11/ AA11 / AE19 / AD19 / AE13 / AD13 / AE10 / AD10 / U14
vdd_dspeve	DSP voltage domain supply	PWR	J13/ K10/ K11/ K12/ K13/ L10/ L11/ L12/ M10/ M11/ M12/ M13
vdd_iva	IVA voltage domain supply	PWR	U18/ U19/ V18/ V19
vdd_gpu	GPU voltage domain supply	PWR	U11/ U12/ V10/ V11/ V14/ W10/ W11/ W13
vdd_mpu	MPU voltage domain supply	PWR	K17/ K18/ L15/ L16/ L17/ L18/ L19/ M15/ M16/ M17/ M18/ N17/ N18/ P17/ P18/ R18
vdd_rtc	RTC voltage domain supply	PWR	AB15
vdda_usb1	DPLL_USB and HS USB1 1.8V analog power supply	PWR	AA13
vdda_usb2	HS USB2 1.8V analog power supply	PWR	AB12
vdda33v_usb1	HS USB1 3.3V analog power supply. If USB1 is not used, this pin can alternatively be connected to VSS if the following requirements are met: - The usb1_dm/usb1_dp pins are left unconnected - The USB1 PHY is kept powered down	PWR	AA12
vdda33v_usb2	HS USB2 3.3V analog power supply. If USB2 is not used, this pin can alternatively be connected to VSS if the following requirements are met: - The usb2_dm/usb2_dp pins are left unconnected - The USB2 PHY is kept powered down	PWR	Y12
vdda_abe_per	DPLL_ABE, DPLL_PER, and PER HSDIVIDER analog power supply	PWR	M14
vdda_ddr	DPLL_DDR and DDR HSDIVIDER analog power supply	PWR	P16
vdda_debug	DPLL_DEBUG analog power supply	PWR	N11
vdda_dsp_eve	DPLL_DSP analog power supply	PWR	N12
vdda_gmac_core	DPLL_CORE and CORE HSDIVIDER analog power supply	PWR	P15
vdda_gpu	DPLL_GPU analog power supply	PWR	R14
vdda_hdmi	PLL_HDMI and HDMI analog power supply	PWR	Y17
vdda_iva	DPLL_IVA analog power supply	PWR	R17
vdda_pcie	DPLL_PCIE_REF and PCIe analog power supply	PWR	W14
vdda_pcie0	PCIe ch0 RX/TX analog power supply	PWR	AA17
vdda_pcie1	PCIe ch1 RX/TX analog power supply	PWR	AA16
vdda_sata	DPLL_SATA and SATA RX/TX analog power supply	PWR	V13
vdda_usb3	DPLL_USB_OTG_SS and USB3.0 RX/TX analog power supply	PWR	W12
vdda_video	DPLL_VIDEO1 and DPLL_VIDEO2 analog power supply	PWR	P14

**Table 4-32. Power Supply Signal Descriptions (continued)**

SIGNAL NAME	DESCRIPTION	TYPE	BALL
vdds_mlbp	MLBP IO power supply	PWR	AA7/ Y7
vdda_mpu	DPLL_MPU analog power supply	PWR	N16
vdda_osc	HFOSC analog power supply	PWR	AE16/ AD16
vssa_osc0	OSC0 analog ground	GND	AF15
vssa_osc1	OSC1 analog ground	GND	AC14
vdda_rtc	RTC bias and RTC LFOSC analog power supply	PWR	AB13
vdds18v	1.8V power supply	PWR	W17/ W18/ V21/ V22/ T8/ R8/ P8/ N8/ M8/ M9/ H17/ G18
vdds18v_dds1	DDR1 bias power supply	PWR	AA18/ AA19/ Y21/ W21
vdds18v_dds2	DDR2 bias power supply	PWR	P20/ P21/ N21/ J21/ J22
vdds_dds2	DDR2 power supply (1.8V for DDR2 mode/ 1.5V for DDR3 mode / 1.35V for DDR3L mode)	PWR	T24/ T25/ M20/ M21/ L20/ L21/ J27/ H20/ H21/ H22/ G22/ G23/ E24
vdds_dds1	DDR1 power supply (1.8V for DDR2 mode/ 1.5V for DDR3 mode / 1.35V for DDR3L mode)	PWR	AH27/ AG20/ AG28/ AD26/ AC22/ AB21/ AB22/ AB24/ AB25/ AA21/ AA22/ W16/ W27
vddshv5	Dual Voltage (1.8V or 3.3V) power supply for the RTC Power Group pins	PWR	V12
vddshv1	Dual Voltage (1.8V or 3.3V) power supply for the VIN2 Power Group pins	PWR	H8/ H9/ G4/ G5/ E3/ E5
vddshv10	Dual Voltage (1.8V or 3.3V) power supply for the GPMC Power Group pins	PWR	T4/ T5/ R7/ R10/ P10/ N4/ N5
vddshv11	Dual Voltage (1.8V or 3.3V) power supply for the MMC2 Power Group pins	PWR	K8/ J8
vddshv2	Dual Voltage (1.8V or 3.3V) power supply for the VOUT Power Group pins	PWR	H10/ H11/ E10/ D10/ B6
vddshv3	Dual Voltage (1.8V or 3.3V) power supply for the GENERAL Power Group pins	PWR	H15/ H16/ H18/ H19/ G15/ E16/ E22/ D16/ D22/ B23
vddshv4	Dual Voltage (1.8V or 3.3V) power supply for the MMC4 Power Group pins	PWR	C24
vddshv6	Dual Voltage (1.8V or 3.3V) power supply for the VIN1 Power Group pins	PWR	AF5/ AE7/ AD5/ AD7
vddshv7	Dual Voltage (1.8V or 3.3V) power supply for the WIFI Power Group pins	PWR	AB6/ AB7
vddshv8	Dual Voltage (1.8V or 3.3V) power supply for the MMC1 Power Group pins	PWR	Y8/ W8
vddshv9	Dual Voltage (1.8V or 3.3V) power supply for the RGMII Power Group pins	PWR	W4/ W5/ U10
cap_vddram_dspeve2 <sup>(1)</sup>	External capacitor connection for the DSP SRAM array Ido2 output	CAP	J9
cap_vddram_dspeve1 <sup>(1)</sup>	External capacitor connection for the DSP SRAM array Ido1 output	CAP	J10
cap_vbbldo_mpu <sup>(1)</sup>	External capacitor connection for the MPU vbb Ido output	CAP	J16
cap_vddram_core2 <sup>(1)</sup>	External capacitor connection for the Core SRAM array Ido2 output	CAP	J19
cap_vbbldo_dspeve <sup>(1)</sup>	External capacitor connection for the DSP vbb Ido output	CAP	K9
cap_vddram_mpu1 <sup>(1)</sup>	External capacitor connection for the MPU SRAM array Ido1 output	CAP	K16
cap_vddram_mpu2 <sup>(1)</sup>	External capacitor connection for the MPU SRAM array Ido2 output	CAP	K19
cap_vddram_core1 <sup>(1)</sup>	External capacitor connection for the Core SRAM array Ido1 output	CAP	L9
cap_vddram_core4 <sup>(1)</sup>	External capacitor connection for the Core SRAM array Ido4 output	CAP	P19
cap_vbbldo_iva <sup>(1)</sup>	External capacitor connection for the IVA vbb Ido output	CAP	R20



**Table 4-32. Power Supply Signal Descriptions (continued)**

SIGNAL NAME	DESCRIPTION	TYPE	BALL
cap_vddram_iva <sup>(1)</sup>	External capacitor connection for the IVA SRAM array Ido output	CAP	T20
cap_vddram_gpu <sup>(1)</sup>	External capacitor connection for the GPU SRAM array Ido output	CAP	Y13
cap_vbbldo_gpu <sup>(1)</sup>	External capacitor connection for the GPU vbb Ido output	CAP	Y14
cap_vddram_core3 <sup>(1)</sup>	External capacitor connection for the Core SRAM array Ido3 output	CAP	Y15
cap_vddram_core5 <sup>(1)</sup>	External capacitor connection for the Core SRAM array Ido5 output	CAP	Y16

(1) This pin must always be connected via a 1- $\mu$ F capacitor to vss.

(2) This signal is valid only for High-Security devices. For more details, see [Section 5.8, VPP Specification for One-Time Programmable \(OTP\) eFUSES](#). For General-purpose devices do not connect any signal, test point, or board trace to this signal.

## 4.4 Pin Multiplexing

[Table 4-33](#) describes the device pin multiplexing (no characteristics are provided in this table).

### NOTE

[Table 4-33, Pin Multiplexing](#) doesn't take into account subsystem multiplexing signals. Subsystem multiplexing signals are described in [Section 4.3, Signal Descriptions](#).

### NOTE

For more information, see the *Control Module / Control Module Functional Description / PAD Functional Multiplexing and Configuration* section in the device TRM.

### NOTE

Configuring two pins to the same input signal is not supported as it can yield unexpected results. This can be easily prevented with the proper software configuration (Hi-Z mode is not an input signal).

### NOTE

In some cases [Table 4-33](#) may present more than one signal name per muxmode for the same ball. First signal in the list is the dominant function as selected via CTRL\_CORE\_PAD\_\* register. All other signals are virtual functions that present alternate multiplexing options. This virtual functions are controlled via CTRL\_CORE\_ALT\_SELECT\_MUX or CTRL\_CORE\_VIP\_MUX\_SELECT register. For more information on how to use this options, please refer to the device TRM, *Control Module* chapter, *Pad Configuration Registers* section.

### NOTE

When a pad is set into a pin multiplexing mode which is not defined, that pad's behavior is undefined. This should be avoided.

### CAUTION

The I/O timings provided in [Section 5.10, Timing Requirements and Switching Characteristics](#) are valid only if signals within a single IOSET are used. The IOSETs are defined in the corresponding tables.

**Table 4-33. Pin Multiplexing**

ADDRESS	REGISTER NAME	BALL NUMBER	MUXMODE FIELD SETTINGS (CTRL_CORE_PAD_*(3:0))															
			0*	1	2*	3	4	5	6	7	8	9	10	11	12	13	14*	15
		P25	ddr2_a6															
		Y23	ddr1_d26															
		Y19	ddr1_d21															
		AE15	xi_osc0															
		AH24	ddr1_nck															
		AG15	ljcb_clkp															
		AF24	ddr1_d4															
		U25	ddr2_wen															
		F27	ddr2_d5															
		V25	ddr1_ecc_d6															
		M27	ddr2_dqsn3															
		G26	ddr2_d12															
		AG19	hdmi1_data2x															
		AF21	ddr1_a4															
		E27	ddr2_d6															
		F24	ddr2_d3															
		H26	ddr2_d11															
		W23	ddr1_ecc_d3															
		Y27	ddr1_dqsn3															
		AC24	ddr1_d14															
		J24	ddr2_d15															
		R26	ddr2_a1															
		G27	ddr2_dqsn0															
		AF28	ddr1_d11															
		AA23	ddr1_d24															
		AD18	ddr1_a15															
		H23	ddr2_d8															
		AH16	hdmi1_clocky															
		AC20	ddr1_a2															
		AA24	ddr1_d27															
		W19	ddr1_ecc_d2															
		L24	ddr2_d20															
		AG11	pcie_rxn1															
		AG21	ddr1_rst															
		AE28	ddr1_dqsn1															

**Table 4-33. Pin Multiplexing (continued)**

ADDRESS	REGISTER NAME	BALL NUMBER	MUXMODE FIELD SETTINGS (CTRL_CORE_PAD_[3:0])																
			0*	1	2*	3	4	5	6	7	8	9	10	11	12	13	14*	15	
		AC11	usb_txn0																
		L22	ddr2_d16																
		U28	ddr2_casn																
		K22	ddr2_d22																
		AG25	ddr1_dqsn0																
		W20	ddr1_d17																
		AF14	rtc_iso																
		AA27	ddr1_dqm3																
		AF25	ddr1_d0																
		AF23	ddr1_d6																
		AG18	hdmi1_data1x																
		AG10	sata1_txn0																
		AF20	ddr1_rasn																
		V26	ddr1_dqm_ecc																
		V20	ddr1_d16																
		G25	ddr2_d1																
		AH13	pcie_rxp0																
		AC18	ddr1_casn																
		AG9	sata1_rxp0																
		AH23	ddr1_csn0																
		AE11	usb2_dp																
		R25	ddr2_a0																
		Y24	ddr1_d28																
		AH15	ljcb_clkn																
		AD20	ddr1_a0																
		AA25	ddr1_d30																
		L23	ddr2_d19																
		AA1	mlbp_dat_p																
		AD14	rtc_osc_xo																
		J25	ddr2_d13																
		AC25	ddr1_d13																
		AB23	ddr1_dqm1																
		U22	ddr2_a15																
		T22	ddr2_a13																
		AH19	hdmi1_data2y																
		M26	ddr2_d31																
		AB27	ddr1_d22																

**Table 4-33. Pin Multiplexing (continued)**

ADDRESS	REGISTER NAME	BALL NUMBER	MUXMODE FIELD SETTINGS (CTRL_CORE_PAD_[3:0])																
			0*	1	2*	3	4	5	6	7	8	9	10	11	12	13	14*	15	
		AG14	pcie_txn0																
		Y28	ddr1_dqs3																
		J20	ddr2_d23																
		AB19	ddr1_a3																
		AH10	sata1_txp0																
		G28	ddr2_dqs0																
		AG24	ddr1_ck																
		AE24	ddr1_d5																
		AC15	xi_osc1																
		AC21	ddr1_a12																
		K28	ddr2_dqsn2																
		AB1	mlbp_clk_p																
		AF12	usb_rxn0																
		L28	ddr2_d27																
		M24	ddr2_d29																
		AH9	sata1_rxn0																
		AC26	ddr1_dqm2																
		AA28	ddr1_d31																
		H28	ddr2_dqsn1																
		AD23	ddr1_dqm0																
		E26	ddr2_d0																
		AE27	ddr1_dqs1																
		AF27	ddr1_d9																
		V24	ddr1_ecc_d5																
		K23	ddr2_dqm2																
		K20	ddr2_d17																
		T28	ddr2_ck																
		H24	ddr2_d10																
		AG27	ddr1_d10																
		R23	ddr2_odt0																
		U27	ddr2_ba1																
		AF22	ddr1_a8																
		AA2	mlbp_dat_n																
		U23	ddr2_ba0																
		AH21	ddr1_wen																
		AE21	ddr1_a7																
		AC12	usb1_dm																
		AH12	pcie_txp1																

**Table 4-33. Pin Multiplexing (continued)**

ADDRESS	REGISTER NAME	BALL NUMBER	MUXMODE FIELD SETTINGS (CTRL_CORE_PAD_[3:0])																
			0*	1	2*	3	4	5	6	7	8	9	10	11	12	13	14*	15	
		Y20	ddr1_d23																
		AC27	ddr1_d20																
		AE23	ddr1_d7																
		T27	ddr2_nck																
		AG22	ddr1_cke																
		AD27	ddr1_dqs2																
		AH14	pcie_txp0																
		AH26	ddr1_d3																
		AD21	ddr1_a10																
		N28	ddr2_a12																
		Y25	ddr1_ecc_d4																
		AE17	ddr1_a14																
		AH18	hdmi1_data1y																
		AH22	ddr1_a5																
		J26	ddr2_d14																
		W22	ddr1_ecc_d0																
		V23	ddr1_ecc_d1																
		AE12	usb_rxp0																
		AE14	rtc_osc_xi_clkin32																
		AH11	pcie_rxp1																
		AB2	mlbp_clk_n																
		AG23	ddr1_a6																
		H27	ddr2_dqs1																
		AB18	ddr1_ba2																
		AG17	hdmi1_data0x																
		AF26	ddr1_d1																
		H25	ddr2_d9																
		M25	ddr2_d30																
		AD11	usb_txp0																
		AC1	mlbp_sig_p																
		L27	ddr2_d24																
		V27	ddr1_dqs_ecc																
		AF17	ddr1_ba0																
		AE26	ddr1_d12																

**Table 4-33. Pin Multiplexing (continued)**

ADDRESS	REGISTER NAME	BALL NUMBER	MUXMODE FIELD SETTINGS (CTRL_CORE_PAD_[3:0])																
			0*	1	2*	3	4	5	6	7	8	9	10	11	12	13	14*	15	
		G24	ddr2_dqm1																
		K27	ddr2_dqs2																
		AC19	ddr1_a1																
		AG13	pcie_rxn0																
		L26	ddr2_d25																
		AB28	ddr1_d18																
		N23	ddr2_a10																
		M22	ddr2_dqm3																
		U26	ddr2_ba2																
		Y26	ddr1_ecc_d7																
		P24	ddr2_csn0																
		R22	ddr2_a14																
		AD22	ddr1_a11																
		N20	ddr2_a7																
		M23	ddr2_d28																
		AD28	ddr1_dqsn2																
		U24	ddr2_cke																
		P22	ddr2_a5																
0x17D4	CTRL_CORE_PAD_DCAN1_RX	G19	dcan1_rx mcan_rx			uart8_txd	mmc2_sdw p	sata1_led			hdmi1_cec							gpio1_15	Driver off
		AE18	ddr1_ba1																
		F26	ddr2_d4																
		AE20	ddr1_odt0																
		N22	ddr2_vref0																
		E28	ddr2_d7																
		F25	ddr2_d2																
		AF11	usb2_dm																
		R24	ddr2_rst																
		AD15	xo_osc0																
		R27	ddr2_a3																
		AE22	ddr1_a9																
		Y18	ddr1_vref0																
0x17D0	CTRL_CORE_PAD_DCAN1_TX	G20	dcan1_tx mcan_tx			uart8_rxd	mmc2_sdccl				hdmi1_hpd							gpio1_14	Driver off
		AC13	xo_osc1																
		F28	ddr2_dqm0																
		J23	ddr2_d21																
		P26	ddr2_a11																
		M28	ddr2_dqs3																

**Table 4-33. Pin Multiplexing (continued)**

ADDRESS	REGISTER NAME	BALL NUMBER	MUXMODE FIELD SETTINGS (CTRL_CORE_PAD_*[3:0])																	
			0*	1	2*	3	4	5	6	7	8	9	10	11	12	13	14*	15		
		AC2	mlbp_sig_n																	
		AD12	usb1_dp																	
		Y22	ddr1_d25																	
		T23	ddr2_rasn																	
		AH17	hdmi1_data0y																	
		N27	ddr2_a9																	
		P23	ddr2_a4																	
		AG26	ddr1_d2																	
		AH25	ddr1_dqs0																	
		AG12	pcie_txn1																	
		AF18	ddr1_a13																	
		K21	ddr2_d18																	
		AC28	ddr1_d19																	
		V28	ddr1_dqsn_ecc																	
		P27	ddr2_a8																	
		AC23	ddr1_d8																	
		F22	porz																	
		L25	ddr2_d26																	
		AG16	hdmi1_clockx																	
		R28	ddr2_a2																	
		AA26	ddr1_d29																	
		AD25	ddr1_d15																	
0x1400	CTRL_CORE_PAD_GPMC_AD0	M6	gpmc_ad0			vin3a_d0	vout3_d0												gpio1_6	sysboot0
0x1404	CTRL_CORE_PAD_GPMC_AD1	M2	gpmc_ad1			vin3a_d1	vout3_d1												gpio1_7	sysboot1
0x1408	CTRL_CORE_PAD_GPMC_AD2	L5	gpmc_ad2			vin3a_d2	vout3_d2												gpio1_8	sysboot2
0x140C	CTRL_CORE_PAD_GPMC_AD3	M1	gpmc_ad3			vin3a_d3	vout3_d3												gpio1_9	sysboot3
0x1410	CTRL_CORE_PAD_GPMC_AD4	L6	gpmc_ad4			vin3a_d4	vout3_d4												gpio1_10	sysboot4
0x1414	CTRL_CORE_PAD_GPMC_AD5	L4	gpmc_ad5			vin3a_d5	vout3_d5												gpio1_11	sysboot5
0x1418	CTRL_CORE_PAD_GPMC_AD6	L3	gpmc_ad6			vin3a_d6	vout3_d6												gpio1_12	sysboot6
0x141C	CTRL_CORE_PAD_GPMC_AD7	L2	gpmc_ad7			vin3a_d7	vout3_d7												gpio1_13	sysboot7
0x1420	CTRL_CORE_PAD_GPMC_AD8	L1	gpmc_ad8			vin3a_d8	vout3_d8												gpio7_18	sysboot8

**Table 4-33. Pin Multiplexing (continued)**

ADDRESS	REGISTER NAME	BALL NUMBER	MUXMODE FIELD SETTINGS (CTRL_CORE_PAD_*[3:0])															
			0*	1	2*	3	4	5	6	7	8	9	10	11	12	13	14*	15
0x1424	CTRL_CORE_PAD_GPMC_AD9	K2	gpmc_ad9		vin3a_d9	vout3_d9											gpio7_19	sysboot9
0x1428	CTRL_CORE_PAD_GPMC_AD10	J1	gpmc_ad10		vin3a_d10	vout3_d10											gpio7_28	sysboot10
0x142C	CTRL_CORE_PAD_GPMC_AD11	J2	gpmc_ad11		vin3a_d11	vout3_d11											gpio7_29	sysboot11
0x1430	CTRL_CORE_PAD_GPMC_AD12	H1	gpmc_ad12		vin3a_d12	vout3_d12											gpio1_18	sysboot12
0x1434	CTRL_CORE_PAD_GPMC_AD13	J3	gpmc_ad13		vin3a_d13	vout3_d13											gpio1_19	sysboot13
0x1438	CTRL_CORE_PAD_GPMC_AD14	H2	gpmc_ad14		vin3a_d14	vout3_d14											gpio1_20	sysboot14
0x143C	CTRL_CORE_PAD_GPMC_AD15	H3	gpmc_ad15		vin3a_d15	vout3_d15											gpio1_21	sysboot15
0x1440	CTRL_CORE_PAD_GPMC_A0	R6	gpmc_a0		vin3a_d16	vout3_d16	vin4a_d0		vin4b_d0	i2c4_scl	uart5_rxd						gpio7_3 gpmc_a26 gpmc_a16	Driver off
0x1444	CTRL_CORE_PAD_GPMC_A1	T9	gpmc_a1		vin3a_d17	vout3_d17	vin4a_d1		vin4b_d1	i2c4_sda	uart5_txd						gpio7_4	Driver off
0x1448	CTRL_CORE_PAD_GPMC_A2	T6	gpmc_a2		vin3a_d18	vout3_d18	vin4a_d2		vin4b_d2	uart7_rxd	uart5_ctsn						gpio7_5	Driver off
0x144C	CTRL_CORE_PAD_GPMC_A3	T7	gpmc_a3	qspi1_cs2	vin3a_d19	vout3_d19	vin4a_d3		vin4b_d3	uart7_txd	uart5_rtsn						gpio7_6	Driver off
0x1450	CTRL_CORE_PAD_GPMC_A4	P6	gpmc_a4	qspi1_cs3	vin3a_d20	vout3_d20	vin4a_d4		vin4b_d4	i2c5_scl	uart6_rxd						gpio1_26	Driver off
0x1454	CTRL_CORE_PAD_GPMC_A5	R9	gpmc_a5		vin3a_d21	vout3_d21	vin4a_d5		vin4b_d5	i2c5_sda	uart6_txd						gpio1_27	Driver off
0x1458	CTRL_CORE_PAD_GPMC_A6	R5	gpmc_a6		vin3a_d22	vout3_d22	vin4a_d6		vin4b_d6	uart8_rxd	uart6_ctsn						gpio1_28	Driver off
0x145C	CTRL_CORE_PAD_GPMC_A7	P5	gpmc_a7		vin3a_d23	vout3_d23	vin4a_d7		vin4b_d7	uart8_txd	uart6_rtsn						gpio1_29	Driver off
0x1460	CTRL_CORE_PAD_GPMC_A8	N7	gpmc_a8		vin3a_hsyn_c0	vout3_hsyn_c			vin4b_hsyn_c1	timer12	spi4_sclk						gpio1_30	Driver off
0x1464	CTRL_CORE_PAD_GPMC_A9	R4	gpmc_a9		vin3a_vsyn_c0	vout3_vsyn_c			vin4b_vsyn_c1	timer11	spi4_d1						gpio1_31	Driver off
0x1468	CTRL_CORE_PAD_GPMC_A10	N9	gpmc_a10		vin3a_de0	vout3_de			vin4b_clk1	timer10	spi4_d0						gpio2_0	Driver off
0x146C	CTRL_CORE_PAD_GPMC_A11	P9	gpmc_a11		vin3a_fld0	vout3_fld	vin4a_fld0		vin4b_de1	timer9	spi4_cs0						gpio2_1	Driver off
0x1470	CTRL_CORE_PAD_GPMC_A12	P4	gpmc_a12				vin4a_clk0	gpmc_a0	vin4b_fld1	timer8	spi4_cs1	dma_evt1					gpio2_2	Driver off
0x1474	CTRL_CORE_PAD_GPMC_A13	R3	gpmc_a13	qspi1_rtclk			vin4a_hsyn_c0			timer7	spi4_cs2	dma_evt2					gpio2_3	Driver off
0x1478	CTRL_CORE_PAD_GPMC_A14	T2	gpmc_a14	qspi1_d3			vin4a_vsyn_c0			timer6	spi4_cs3						gpio2_4	Driver off
0x147C	CTRL_CORE_PAD_GPMC_A15	U2	gpmc_a15	qspi1_d2			vin4a_d8			timer5							gpio2_5	Driver off



**Table 4-33. Pin Multiplexing (continued)**

ADDRESS	REGISTER NAME	BALL NUMBER	MUXMODE FIELD SETTINGS (CTRL_CORE_PAD_*[3:0])															
			0*	1	2*	3	4	5	6	7	8	9	10	11	12	13	14*	15
0x1480	CTRL_CORE_PAD_GPMC_A16	U1	gpmc_a16	qspi1_d0			vin4a_d9										gpio2_6	Driver off
0x1484	CTRL_CORE_PAD_GPMC_A17	P3	gpmc_a17	qspi1_d1			vin4a_d10										gpio2_7	Driver off
0x1488	CTRL_CORE_PAD_GPMC_A18	R2	gpmc_a18	qspi1_sclk			vin4a_d11										gpio2_8	Driver off
0x148C	CTRL_CORE_PAD_GPMC_A19	K7	gpmc_a19	mmc2_dat4	gpmc_a13		vin4a_d12		vin3b_d0								gpio2_9	Driver off
0x1490	CTRL_CORE_PAD_GPMC_A20	M7	gpmc_a20	mmc2_dat5	gpmc_a14		vin4a_d13		vin3b_d1								gpio2_10	Driver off
0x1494	CTRL_CORE_PAD_GPMC_A21	J5	gpmc_a21	mmc2_dat6	gpmc_a15		vin4a_d14		vin3b_d2								gpio2_11	Driver off
0x1498	CTRL_CORE_PAD_GPMC_A22	K6	gpmc_a22	mmc2_dat7	gpmc_a16		vin4a_d15		vin3b_d3								gpio2_12	Driver off
0x149C	CTRL_CORE_PAD_GPMC_A23	J7	gpmc_a23	mmc2_clk	gpmc_a17		vin4a_fld0		vin3b_d4								gpio2_13	Driver off
0x14A0	CTRL_CORE_PAD_GPMC_A24	J4	gpmc_a24	mmc2_dat0	gpmc_a18				vin3b_d5								gpio2_14	Driver off
0x14A4	CTRL_CORE_PAD_GPMC_A25	J6	gpmc_a25	mmc2_dat1	gpmc_a19				vin3b_d6								gpio2_15	Driver off
0x14A8	CTRL_CORE_PAD_GPMC_A26	H4	gpmc_a26	mmc2_dat2	gpmc_a20				vin3b_d7								gpio2_16	Driver off
0x14AC	CTRL_CORE_PAD_GPMC_A27	H5	gpmc_a27	mmc2_dat3	gpmc_a21				vin3b_hsyn_c1								gpio2_17	Driver off
0x14B0	CTRL_CORE_PAD_GPMC_CS1	H6	gpmc_cs1	mmc2_cmd	gpmc_a22		vin4a_de0		vin3b_vsyn_c1								gpio2_18	Driver off
0x14B4	CTRL_CORE_PAD_GPMC_CS0	T1	gpmc_cs0														gpio2_19	Driver off
0x14B8	CTRL_CORE_PAD_GPMC_CS2	P2	gpmc_cs2	qspi1_cs0													gpio2_20 gpmc_a23 gpmc_a13	Driver off
0x14BC	CTRL_CORE_PAD_GPMC_CS3	P1	gpmc_cs3	qspi1_cs1	vin3a_clk0	vout3_clk				gpmc_a1							gpio2_21 gpmc_a24 gpmc_a14	Driver off
0x14C0	CTRL_CORE_PAD_GPMC_CLK	P7	gpmc_clk	gpmc_cs7	clkout1	gpmc_wait1	vin4a_hsyn_c0	vin4a_de0	vin3b_clk1	timer4	i2c3_scl	dma_evt1					gpio2_22 gpmc_a20	Driver off
0x14C4	CTRL_CORE_PAD_GPMC_ADV_N	N1	gpmc_adv_n	gpmc_cs6	clkout2	gpmc_wait1	vin4a_vsyn_c0	gpmc_a2	gpmc_a23	timer3	i2c3_sda	dma_evt2					gpio2_23 gpmc_a19	Driver off
0x14C8	CTRL_CORE_PAD_GPMC_OEN_REN	M5	gpmc_oen_ren														gpio2_24	Driver off
0x14CC	CTRL_CORE_PAD_GPMC_WEN	M3	gpmc_wen														gpio2_25	Driver off
0x14D0	CTRL_CORE_PAD_GPMC_BEN0	N6	gpmc_ben0	gpmc_cs4		vin1b_hsyn_c1			vin3b_de1	timer2		dma_evt3					gpio2_26 gpmc_a21	Driver off
0x14D4	CTRL_CORE_PAD_GPMC_BEN1	M4	gpmc_ben1	gpmc_cs5		vin1b_de1	vin3b_clk1	gpmc_a3	vin3b_fld1	timer1		dma_evt4					gpio2_27 gpmc_a22	Driver off

**Table 4-33. Pin Multiplexing (continued)**

ADDRESS	REGISTER NAME	BALL NUMBER	MUXMODE FIELD SETTINGS (CTRL_CORE_PAD_*[3:0])															
			0*	1	2*	3	4	5	6	7	8	9	10	11	12	13	14*	15
0x14D8	CTRL_CORE_PAD_GPMC_WAIT0	N2	gpmc_wait0														gpio2_28 gpmc_a25 gpmc_a15	Driver off
0x14DC	CTRL_CORE_PAD_VIN1A_CLK0	AG8	vin1a_clk0			vout3_d16	vout3_fld										gpio2_30	Driver off
0x14E0	CTRL_CORE_PAD_VIN1B_CLK1	AH7	vin1b_clk1						vin3a_clk0								gpio2_31	Driver off
0x14E4	CTRL_CORE_PAD_VIN1A_DE0	AD9	vin1a_de0	vin1b_hsyn c1		vout3_d17	vout3_de	uart7_rxd		timer16	spi3_sclk	kbd_row0	eQEP1A_in				gpio3_0	Driver off
0x14E8	CTRL_CORE_PAD_VIN1A_FLD0	AF9	vin1a_fld0	vin1b_vsyn c1			vout3_clk	uart7_txd		timer15	spi3_d1	kbd_row1	eQEP1B_in				gpio3_1	Driver off
0x14EC	CTRL_CORE_PAD_VIN1A_HSYNCO	AE9	vin1a_hsyn c0	vin1b_fld1			vout3_hsyn c	uart7_ctsn		timer14	spi3_d0		eQEP1_ind ex				gpio3_2	Driver off
0x14F0	CTRL_CORE_PAD_VIN1A_VSYNCO	AF8	vin1a_vsyn c0	vin1b_de1			vout3_vsyn c	uart7_rtsn		timer13	spi3_cs0		eQEP1_str obe				gpio3_3	Driver off
0x14F4	CTRL_CORE_PAD_VIN1A_D0	AE8	vin1a_d0			vout3_d7	vout3_d23	uart8_rxd					ehrpwm1A				gpio3_4	Driver off
0x14F8	CTRL_CORE_PAD_VIN1A_D1	AD8	vin1a_d1			vout3_d6	vout3_d22	uart8_txd					ehrpwm1B				gpio3_5	Driver off
0x14FC	CTRL_CORE_PAD_VIN1A_D2	AG7	vin1a_d2			vout3_d5	vout3_d21	uart8_ctsn					ehrpwm1_tr ipzone_inpu t				gpio3_6	Driver off
0x1500	CTRL_CORE_PAD_VIN1A_D3	AH6	vin1a_d3			vout3_d4	vout3_d20	uart8_rtsn					eCAP1_in_ PWM1_out	pr1_pru0_g pi0	pr1_pru0_g po0	gpio3_7	Driver off	
0x1504	CTRL_CORE_PAD_VIN1A_D4	AH3	vin1a_d4			vout3_d3	vout3_d19						ehrpwm1_s ynci	pr1_pru0_g pi1	pr1_pru0_g po1	gpio3_8	Driver off	
0x1508	CTRL_CORE_PAD_VIN1A_D5	AH5	vin1a_d5			vout3_d2	vout3_d18						ehrpwm1_s ynco	pr1_pru0_g pi2	pr1_pru0_g po2	gpio3_9	Driver off	
0x150C	CTRL_CORE_PAD_VIN1A_D6	AG6	vin1a_d6			vout3_d1	vout3_d17						eQEP2A_in	pr1_pru0_g pi3	pr1_pru0_g po3	gpio3_10	Driver off	
0x1510	CTRL_CORE_PAD_VIN1A_D7	AH4	vin1a_d7			vout3_d0	vout3_d16						eQEP2B_in	pr1_pru0_g pi4	pr1_pru0_g po4	gpio3_11	Driver off	
0x1514	CTRL_CORE_PAD_VIN1A_D8	AG4	vin1a_d8	vin1b_d7			vout3_d15					kbd_row2	eQEP2_ind ex	pr1_pru0_g pi5	pr1_pru0_g po5	gpio3_12	Driver off	
0x1518	CTRL_CORE_PAD_VIN1A_D9	AG2	vin1a_d9	vin1b_d6			vout3_d14					kbd_row3	eQEP2_str obe	pr1_pru0_g pi6	pr1_pru0_g po6	gpio3_13	Driver off	
0x151C	CTRL_CORE_PAD_VIN1A_D10	AG3	vin1a_d10	vin1b_d5			vout3_d13					kbd_row4	pr1_edc_lat ch0_in	pr1_pru0_g pi7	pr1_pru0_g po7	gpio3_14	Driver off	
0x1520	CTRL_CORE_PAD_VIN1A_D11	AG5	vin1a_d11	vin1b_d4			vout3_d12	gpmc_a23				kbd_row5	pr1_edc_lat ch1_in	pr1_pru0_g pi8	pr1_pru0_g po8	gpio3_15	Driver off	
0x1524	CTRL_CORE_PAD_VIN1A_D12	AF2	vin1a_d12	vin1b_d3			vout3_d11	gpmc_a24				kbd_row6	pr1_edc_sy nc0_out	pr1_pru0_g pi9	pr1_pru0_g po9	gpio3_16	Driver off	
0x1528	CTRL_CORE_PAD_VIN1A_D13	AF6	vin1a_d13	vin1b_d2			vout3_d10	gpmc_a25				kbd_row7	pr1_edc_sy nc1_out	pr1_pru0_g pi10	pr1_pru0_g po10	gpio3_17	Driver off	
0x152C	CTRL_CORE_PAD_VIN1A_D14	AF3	vin1a_d14	vin1b_d1			vout3_d9	gpmc_a26				kbd_row8	pr1_edio_la tch_in	pr1_pru0_g pi11	pr1_pru0_g po11	gpio3_18	Driver off	
0x1530	CTRL_CORE_PAD_VIN1A_D15	AF4	vin1a_d15	vin1b_d0			vout3_d8	gpmc_a27				kbd_col0	pr1_edio_s of	pr1_pru0_g pi12	pr1_pru0_g po12	gpio3_19	Driver off	

**Table 4-33. Pin Multiplexing (continued)**

ADDRESS	REGISTER NAME	BALL NUMBER	MUXMODE FIELD SETTINGS (CTRL_CORE_PAD_*[3:0])															
			0*	1	2*	3	4	5	6	7	8	9	10	11	12	13	14*	15
0x1534	CTRL_CORE_PAD_VIN1A_D16	AF1	vin1a_d16	vin1b_d7			vout3_d7		vin3a_d0			kbd_col1	pr1_edio_d_ata_in0	pr1_edio_d_ata_out0	pr1_pru0_g_pi13	pr1_pru0_g_pi13	gpio3_20	Driver off
0x1538	CTRL_CORE_PAD_VIN1A_D17	AE3	vin1a_d17	vin1b_d6			vout3_d6		vin3a_d1			kbd_col2	pr1_edio_d_ata_in1	pr1_edio_d_ata_out1	pr1_pru0_g_pi14	pr1_pru0_g_pi14	gpio3_21	Driver off
0x153C	CTRL_CORE_PAD_VIN1A_D18	AE5	vin1a_d18	vin1b_d5			vout3_d5		vin3a_d2			kbd_col3	pr1_edio_d_ata_in2	pr1_edio_d_ata_out2	pr1_pru0_g_pi15	pr1_pru0_g_pi15	gpio3_22	Driver off
0x1540	CTRL_CORE_PAD_VIN1A_D19	AE1	vin1a_d19	vin1b_d4			vout3_d4		vin3a_d3			kbd_col4	pr1_edio_d_ata_in3	pr1_edio_d_ata_out3	pr1_pru0_g_pi16	pr1_pru0_g_pi16	gpio3_23	Driver off
0x1544	CTRL_CORE_PAD_VIN1A_D20	AE2	vin1a_d20	vin1b_d3			vout3_d3		vin3a_d4			kbd_col5	pr1_edio_d_ata_in4	pr1_edio_d_ata_out4	pr1_pru0_g_pi17	pr1_pru0_g_pi17	gpio3_24	Driver off
0x1548	CTRL_CORE_PAD_VIN1A_D21	AE6	vin1a_d21	vin1b_d2			vout3_d2		vin3a_d5			kbd_col6	pr1_edio_d_ata_in5	pr1_edio_d_ata_out5	pr1_pru0_g_pi18	pr1_pru0_g_pi18	gpio3_25	Driver off
0x154C	CTRL_CORE_PAD_VIN1A_D22	AD2	vin1a_d22	vin1b_d1			vout3_d1		vin3a_d6			kbd_col7	pr1_edio_d_ata_in6	pr1_edio_d_ata_out6	pr1_pru0_g_pi19	pr1_pru0_g_pi19	gpio3_26	Driver off
0x1550	CTRL_CORE_PAD_VIN1A_D23	AD3	vin1a_d23	vin1b_d0			vout3_d0		vin3a_d7			kbd_col8	pr1_edio_d_ata_in7	pr1_edio_d_ata_out7	pr1_pru0_g_pi20	pr1_pru0_g_pi20	gpio3_27	Driver off
0x1554	CTRL_CORE_PAD_VIN2A_CLK0	E1	vin2a_clk0				vout2_fld	emu5				kbd_row0	eQEP1A_in		pr1_edio_d_ata_out0	pr1_edio_d_ata_out0	gpio3_28	Driver off
0x1558	CTRL_CORE_PAD_VIN2A_DE0	G2	vin2a_de0	vin2a_fld0	vin2b_fld1	vin2b_de1	vout2_de	emu6				kbd_row1	eQEP1B_in		pr1_edio_d_ata_out1	pr1_edio_d_ata_out1	gpio3_29	Driver off
0x155C	CTRL_CORE_PAD_VIN2A_FLD0	H7	vin2a_fld0		vin2b_clk1		vout2_clk	emu7					eQEP1_ind_ex		pr1_edio_d_ata_in2	pr1_edio_d_ata_out2	gpio3_30	Driver off
0x1560	CTRL_CORE_PAD_VIN2A_HSYNCO	G1	vin2a_hsynco		vin2b_hsync1	vout2_hsync	emu8			uart9_rxd	spi4_sclk	kbd_row2	eQEP1_str_obe	pr1_uart0_cts_n	pr1_edio_d_ata_in3	pr1_edio_d_ata_out3	gpio3_31	Driver off
0x1564	CTRL_CORE_PAD_VIN2A_VSYNCO	G6	vin2a_vsynco		vin2b_vsync1	vout2_vsync	emu9			uart9_txd	spi4_d1	kbd_row3	ehrpwm1A	pr1_uart0_rts_n	pr1_edio_d_ata_in4	pr1_edio_d_ata_out4	gpio4_0	Driver off
0x1568	CTRL_CORE_PAD_VIN2A_D0	F2	vin2a_d0			vout2_d23	emu10			uart9_ctsn	spi4_d0	kbd_row4	ehrpwm1B	pr1_uart0_rxd	pr1_edio_d_ata_in5	pr1_edio_d_ata_out5	gpio4_1	Driver off
0x156C	CTRL_CORE_PAD_VIN2A_D1	F3	vin2a_d1			vout2_d22	emu11			uart9_rtsn	spi4_cs0	kbd_row5	ehrpwm1_tripzone_input	pr1_uart0_txd	pr1_edio_d_ata_in6	pr1_edio_d_ata_out6	gpio4_2	Driver off
0x1570	CTRL_CORE_PAD_VIN2A_D2	D1	vin2a_d2			vout2_d21	emu12			uart10_rxd	kbd_row6	eCAP1_in_PWM1_out	pr1_ecap0_ecap_capin_apwm_o	pr1_edio_d_ata_in7	pr1_edio_d_ata_out7	gpio4_3	Driver off	
0x1574	CTRL_CORE_PAD_VIN2A_D3	E2	vin2a_d3			vout2_d20	emu13			uart10_txd	kbd_col0	ehrpwm1_synci	pr1_edc_lat_ch0_in	pr1_pru1_g_pi0	pr1_pru1_g_pi0	gpio4_4	Driver off	
0x1578	CTRL_CORE_PAD_VIN2A_D4	D2	vin2a_d4			vout2_d19	emu14			uart10_ctsn	kbd_col1	ehrpwm1_synco	pr1_edc_synco_out	pr1_pru1_g_pi1	pr1_pru1_g_pi1	gpio4_5	Driver off	
0x157C	CTRL_CORE_PAD_VIN2A_D5	F4	vin2a_d5			vout2_d18	emu15			uart10_rtsn	kbd_col2	eQEP2A_in	pr1_edio_s_of	pr1_pru1_g_pi2	pr1_pru1_g_pi2	gpio4_6	Driver off	
0x1580	CTRL_CORE_PAD_VIN2A_D6	C1	vin2a_d6			vout2_d17	emu16			mii1_rxd1	kbd_col3	eQEP2B_in	pr1_mii_mt1_clk	pr1_pru1_g_pi3	pr1_pru1_g_pi3	gpio4_7	Driver off	
0x1584	CTRL_CORE_PAD_VIN2A_D7	E4	vin2a_d7			vout2_d16	emu17			mii1_rxd2	kbd_col4	eQEP2_ind_ex	pr1_mii1_txen	pr1_pru1_g_pi4	pr1_pru1_g_pi4	gpio4_8	Driver off	
0x1588	CTRL_CORE_PAD_VIN2A_D8	F5	vin2a_d8			vout2_d15	emu18			mii1_rxd3	kbd_col5	eQEP2_str_obe	pr1_mii1_tx_d3	pr1_pru1_g_pi5	pr1_pru1_g_pi5	gpio4_9	Driver off	

**Table 4-33. Pin Multiplexing (continued)**

ADDRESS	REGISTER NAME	BALL NUMBER	MUXMODE FIELD SETTINGS (CTRL_CORE_PAD_*[3:0])																
			0*	1	2*	3	4	5	6	7	8	9	10	11	12	13	14*	15	
0x158C	CTRL_CORE_PAD_VIN2A_D9	E6	vin2a_d9				vout2_d14	emu19				mii1_rxd0	kbd_col6	ehrpwm2A	pr1_mii1_tx d2	pr1_pru1_g pi6	pr1_pru1_g po6	gpio4_10 gpmc_a25	Driver off
0x1590	CTRL_CORE_PAD_VIN2A_D10	D3	vin2a_d10			mdio_mclk	vout2_d13						kbd_col7	ehrpwm2B	pr1_mdio_mdclk	pr1_pru1_g pi7	pr1_pru1_g po7	gpio4_11 gpmc_a24	Driver off
0x1594	CTRL_CORE_PAD_VIN2A_D11	F6	vin2a_d11			mdio_d	vout2_d12						kbd_row7	ehrpwm2_tr ipzone_inpu t	pr1_mdio_ata	pr1_pru1_g pi8	pr1_pru1_g po8	gpio4_12 gpmc_a23	Driver off
0x1598	CTRL_CORE_PAD_VIN2A_D12	D5	vin2a_d12			rgmii1_txc	vout2_d11					mii1_rxclk	kbd_col8	eCAP2_in_PWM2_out	pr1_mii1_tx d1	pr1_pru1_g pi9	pr1_pru1_g po9	gpio4_13	Driver off
0x159C	CTRL_CORE_PAD_VIN2A_D13	C2	vin2a_d13			rgmii1_txcctl	vout2_d10					mii1_rxdv	kbd_row8	eQEP3A_in	pr1_mii1_tx d0	pr1_pru1_g pi10	pr1_pru1_g po10	gpio4_14	Driver off
0x15A0	CTRL_CORE_PAD_VIN2A_D14	C3	vin2a_d14			rgmii1_txd3	vout2_d9					mii1_txclk		eQEP3B_in	pr1_mii_mr 1_clk	pr1_pru1_g pi11	pr1_pru1_g po11	gpio4_15	Driver off
0x15A4	CTRL_CORE_PAD_VIN2A_D15	C4	vin2a_d15			rgmii1_txd2	vout2_d8					mii1_txd0		eQEP3_ind ex	pr1_mii1_rx dv	pr1_pru1_g pi12	pr1_pru1_g po12	gpio4_16	Driver off
0x15A8	CTRL_CORE_PAD_VIN2A_D16	B2	vin2a_d16		vin2b_d7	rgmii1_txd1	vout2_d7		vin3a_d8			mii1_txd1		eQEP3_str obe	pr1_mii1_rx d3	pr1_pru1_g pi13	pr1_pru1_g po13	gpio4_24	Driver off
0x15AC	CTRL_CORE_PAD_VIN2A_D17	D6	vin2a_d17		vin2b_d6	rgmii1_txd0	vout2_d6		vin3a_d9			mii1_txd2		ehrpwm3A	pr1_mii1_rx d2	pr1_pru1_g pi14	pr1_pru1_g po14	gpio4_25	Driver off
0x15B0	CTRL_CORE_PAD_VIN2A_D18	C5	vin2a_d18		vin2b_d5	rgmii1_rxc	vout2_d5		vin3a_d10			mii1_txd3		ehrpwm3B	pr1_mii1_rx d1	pr1_pru1_g pi15	pr1_pru1_g po15	gpio4_26	Driver off
0x15B4	CTRL_CORE_PAD_VIN2A_D19	A3	vin2a_d19		vin2b_d4	rgmii1_rxcctl	vout2_d4		vin3a_d11			mii1_txer		ehrpwm3_tr ipzone_inpu t	pr1_mii1_rx d0	pr1_pru1_g pi16	pr1_pru1_g po16	gpio4_27	Driver off
0x15B8	CTRL_CORE_PAD_VIN2A_D20	B3	vin2a_d20		vin2b_d3	rgmii1_rxd3	vout2_d3	vin3a_de0	vin3a_d12			mii1_rxer		eCAP3_in_PWM3_out	pr1_mii1_rx er	pr1_pru1_g pi17	pr1_pru1_g po17	gpio4_28	Driver off
0x15BC	CTRL_CORE_PAD_VIN2A_D21	B4	vin2a_d21		vin2b_d2	rgmii1_rxd2	vout2_d2	vin3a_fld0	vin3a_d13			mii1_col			pr1_mii1_rx link	pr1_pru1_g pi18	pr1_pru1_g po18	gpio4_29	Driver off
0x15C0	CTRL_CORE_PAD_VIN2A_D22	B5	vin2a_d22		vin2b_d1	rgmii1_rxd1	vout2_d1	vin3a_hsyn c0	vin3a_d14			mii1_crs			pr1_mii1_c ol	pr1_pru1_g pi19	pr1_pru1_g po19	gpio4_30	Driver off
0x15C4	CTRL_CORE_PAD_VIN2A_D23	A4	vin2a_d23		vin2b_d0	rgmii1_rxd0	vout2_d0	vin3a_vsyn c0	vin3a_d15			mii1_txen			pr1_mii1_cr s	pr1_pru1_g pi20	pr1_pru1_g po20	gpio4_31	Driver off
0x15C8	CTRL_CORE_PAD_VOUT1_CLK	D11	vout1_clk			vin4a_fld0	vin3a_fld0					spi3_cs0						gpio4_19	Driver off
0x15CC	CTRL_CORE_PAD_VOUT1_DE	B10	vout1_de			vin4a_de0	vin3a_de0					spi3_d1						gpio4_20	Driver off
0x15D0	CTRL_CORE_PAD_VOUT1_FLD	B11	vout1_fld			vin4a_clk0	vin3a_clk0					spi3_cs1						gpio4_21	Driver off
0x15D4	CTRL_CORE_PAD_VOUT1_HSYNC	C11	vout1_hsyn c			vin4a_hsyn c0	vin3a_hsyn c0					spi3_d0						gpio4_22	Driver off
0x15D8	CTRL_CORE_PAD_VOUT1_VSYNC	E11	vout1_vsyn c			vin4a_vsyn c0	vin3a_vsyn c0					spi3_sclk				pr2_pru1_g pi17	pr2_pru1_g po17	gpio4_23	Driver off
0x15DC	CTRL_CORE_PAD_VOUT1_D0	F11	vout1_d0		uart5_rxd	vin4a_d16	vin3a_d16					spi3_cs2		pr1_uart0_c ts_n		pr2_pru1_g pi18	pr2_pru1_g po18	gpio8_0	Driver off
0x15E0	CTRL_CORE_PAD_VOUT1_D1	G10	vout1_d1		uart5_txd	vin4a_d17	vin3a_d17							pr1_uart0_r ts_n		pr2_pru1_g pi19	pr2_pru1_g po19	gpio8_1	Driver off
0x15E4	CTRL_CORE_PAD_VOUT1_D2	F10	vout1_d2		emu2	vin4a_d18	vin3a_d18	obs0	obs16	obs_irq1				pr1_uart0_r xd		pr2_pru1_g pi20	pr2_pru1_g po20	gpio8_2	Driver off

**Table 4-33. Pin Multiplexing (continued)**

ADDRESS	REGISTER NAME	BALL NUMBER	MUXMODE FIELD SETTINGS (CTRL_CORE_PAD_*[3:0])															
			0*	1	2*	3	4	5	6	7	8	9	10	11	12	13	14*	15
0x15E8	CTRL_CORE_PAD_VOUT1_D3	G11	vout1_d3		emu5	vin4a_d19	vin3a_d19	obs1	obs17	obs_dmarq1			pr1_uart0_txd		pr2_pru0_gpi0	pr2_pru0_gpo0	gpio8_3	Driver off
0x15EC	CTRL_CORE_PAD_VOUT1_D4	E9	vout1_d4		emu6	vin4a_d20	vin3a_d20	obs2	obs18				pr1_ecap0_ecap_capin_apwm_o		pr2_pru0_gpi1	pr2_pru0_gpo1	gpio8_4	Driver off
0x15F0	CTRL_CORE_PAD_VOUT1_D5	F9	vout1_d5		emu7	vin4a_d21	vin3a_d21	obs3	obs19				pr2_edc_lat_ch0_in		pr2_pru0_gpi2	pr2_pru0_gpo2	gpio8_5	Driver off
0x15F4	CTRL_CORE_PAD_VOUT1_D6	F8	vout1_d6		emu8	vin4a_d22	vin3a_d22	obs4	obs20				pr2_edc_lat_ch1_in		pr2_pru0_gpi3	pr2_pru0_gpo3	gpio8_6	Driver off
0x15F8	CTRL_CORE_PAD_VOUT1_D7	E7	vout1_d7		emu9	vin4a_d23	vin3a_d23						pr2_edc_sync0_out		pr2_pru0_gpi4	pr2_pru0_gpo4	gpio8_7	Driver off
0x15FC	CTRL_CORE_PAD_VOUT1_D8	E8	vout1_d8		uart6_rxd	vin4a_d8	vin3a_d8						pr2_edc_sync1_out		pr2_pru0_gpi5	pr2_pru0_gpo5	gpio8_8	Driver off
0x1600	CTRL_CORE_PAD_VOUT1_D9	D9	vout1_d9		uart6_txd	vin4a_d9	vin3a_d9						pr2_edio_latch_in		pr2_pru0_gpi6	pr2_pru0_gpo6	gpio8_9	Driver off
0x1604	CTRL_CORE_PAD_VOUT1_D10	D7	vout1_d10		emu3	vin4a_d10	vin3a_d10	obs5	obs21	obs_irq2			pr2_edio_sof		pr2_pru0_gpi7	pr2_pru0_gpo7	gpio8_10	Driver off
0x1608	CTRL_CORE_PAD_VOUT1_D11	D8	vout1_d11		emu10	vin4a_d11	vin3a_d11	obs6	obs22	obs_dmarq2			pr2_uart0_csts_n		pr2_pru0_gpi8	pr2_pru0_gpo8	gpio8_11	Driver off
0x160C	CTRL_CORE_PAD_VOUT1_D12	A5	vout1_d12		emu11	vin4a_d12	vin3a_d12	obs7	obs23				pr2_uart0_rts_n		pr2_pru0_gpi9	pr2_pru0_gpo9	gpio8_12	Driver off
0x1610	CTRL_CORE_PAD_VOUT1_D13	C6	vout1_d13		emu12	vin4a_d13	vin3a_d13	obs8	obs24				pr2_uart0_rxd		pr2_pru0_gpi10	pr2_pru0_gpo10	gpio8_13	Driver off
0x1614	CTRL_CORE_PAD_VOUT1_D14	C8	vout1_d14		emu13	vin4a_d14	vin3a_d14	obs9	obs25				pr2_uart0_txd		pr2_pru0_gpi11	pr2_pru0_gpo11	gpio8_14	Driver off
0x1618	CTRL_CORE_PAD_VOUT1_D15	C7	vout1_d15		emu14	vin4a_d15	vin3a_d15	obs10	obs26				pr2_ecap0_ecap_capin_apwm_o		pr2_pru0_gpi12	pr2_pru0_gpo12	gpio8_15	Driver off
0x161C	CTRL_CORE_PAD_VOUT1_D16	B7	vout1_d16		uart7_rxd	vin4a_d0	vin3a_d0						pr2_edio_data_in0	pr2_edio_data_out0	pr2_pru0_gpi13	pr2_pru0_gpo13	gpio8_16	Driver off
0x1620	CTRL_CORE_PAD_VOUT1_D17	B8	vout1_d17		uart7_txd	vin4a_d1	vin3a_d1						pr2_edio_data_in1	pr2_edio_data_out1	pr2_pru0_gpi14	pr2_pru0_gpo14	gpio8_17	Driver off
0x1624	CTRL_CORE_PAD_VOUT1_D18	A7	vout1_d18		emu4	vin4a_d2	vin3a_d2	obs11	obs27				pr2_edio_data_in2	pr2_edio_data_out2	pr2_pru0_gpi15	pr2_pru0_gpo15	gpio8_18	Driver off
0x1628	CTRL_CORE_PAD_VOUT1_D19	A8	vout1_d19		emu15	vin4a_d3	vin3a_d3	obs12	obs28				pr2_edio_data_in3	pr2_edio_data_out3	pr2_pru0_gpi16	pr2_pru0_gpo16	gpio8_19	Driver off
0x162C	CTRL_CORE_PAD_VOUT1_D20	C9	vout1_d20		emu16	vin4a_d4	vin3a_d4	obs13	obs29				pr2_edio_data_in4	pr2_edio_data_out4	pr2_pru0_gpi17	pr2_pru0_gpo17	gpio8_20	Driver off
0x1630	CTRL_CORE_PAD_VOUT1_D21	A9	vout1_d21		emu17	vin4a_d5	vin3a_d5	obs14	obs30				pr2_edio_data_in5	pr2_edio_data_out5	pr2_pru0_gpi18	pr2_pru0_gpo18	gpio8_21	Driver off
0x1634	CTRL_CORE_PAD_VOUT1_D22	B9	vout1_d22		emu18	vin4a_d6	vin3a_d6	obs15	obs31				pr2_edio_data_in6	pr2_edio_data_out6	pr2_pru0_gpi19	pr2_pru0_gpo19	gpio8_22	Driver off
0x1638	CTRL_CORE_PAD_VOUT1_D23	A10	vout1_d23		emu19	vin4a_d7	vin3a_d7						pr2_edio_data_in7	pr2_edio_data_out7	pr2_pru0_gpi20	pr2_pru0_gpo20	gpio8_23	Driver off
0x163C	CTRL_CORE_PAD_MDIO_MCLK	V1	mdio_mclk	uart3_rtsn		mii0_col	vin2a_clk0	vin4b_clk1						pr1_mii0_col	pr2_pru1_gpi0	pr2_pru1_gpo0	gpio5_15	Driver off
0x1640	CTRL_CORE_PAD_MDIO_D	U4	mdio_d	uart3_ctsn		mii0_txer	vin2a_d0	vin4b_d0						pr1_mii0_rlink	pr2_pru1_gpi1	pr2_pru1_gpo1	gpio5_16	Driver off

**Table 4-33. Pin Multiplexing (continued)**

ADDRESS	REGISTER NAME	BALL NUMBER	MUXMODE FIELD SETTINGS (CTRL_CORE_PAD_*[3:0])																		
			0*	1	2*	3	4	5	6	7	8	9	10	11	12	13	14*	15			
0x1644	CTRL_CORE_PAD_RMII_MHZ_50_CLK	U3	RMII_MHZ_50_CLK				vin2a_d11										pr2_pru1_gpi2	pr2_pru1_gpo2	gpio5_17	Driver off	
0x1648	CTRL_CORE_PAD_UART3_RXD	V2	uart3_rxd		rmii1_crs	mii0_rxdv	vin2a_d1	vin4b_d1			spi3_sclk						pr1_mii0_rxdv	pr2_pru1_gpi3	pr2_pru1_gpo3	gpio5_18	Driver off
0x164C	CTRL_CORE_PAD_UART3_TXD	Y1	uart3_txd		rmii1_rxer	mii0_rxcclk	vin2a_d2	vin4b_d2			spi3_d1	spi4_cs1					pr1_mii_mr0_clk	pr2_pru1_gpi4	pr2_pru1_gpo4	gpio5_19	Driver off
0x1650	CTRL_CORE_PAD_RGMII0_TXC	W9	rgmii0_txc	uart3_ctsn	rmii1_rxd1	mii0_rxd3	vin2a_d3	vin4b_d3			spi3_d0	spi4_cs2					pr1_mii0_rxd3	pr2_pru1_gpi5	pr2_pru1_gpo5	gpio5_20	Driver off
0x1654	CTRL_CORE_PAD_RGMII0_TXCTL	V9	rgmii0_txctl	uart3_rtsn	rmii1_rxd0	mii0_rxd2	vin2a_d4	vin4b_d4			spi3_cs0	spi4_cs3					pr1_mii0_rxd2	pr2_pru1_gpi6	pr2_pru1_gpo6	gpio5_21	Driver off
0x1658	CTRL_CORE_PAD_RGMII0_TXD3	V7	rgmii0_txd3	rmii0_crs		mii0_crs	vin2a_de0	vin4b_de1			spi4_sclk	uart4_rxd					pr1_mii0_crs	pr2_pru1_gpi7	pr2_pru1_gpo7	gpio5_22	Driver off
0x165C	CTRL_CORE_PAD_RGMII0_TXD2	U7	rgmii0_txd2	rmii0_rxer		mii0_rxer	vin2a_hsync0	vin4b_hsync1			spi4_d1	uart4_txd					pr1_mii0_rxer	pr2_pru1_gpi8	pr2_pru1_gpo8	gpio5_23	Driver off
0x1660	CTRL_CORE_PAD_RGMII0_RXD1	V6	rgmii0_txd1	rmii0_rxd1		mii0_rxd1	vin2a_vsync0	vin4b_vsync1			spi4_d0	uart4_ctsn					pr1_mii0_rxd1	pr2_pru1_gpi9	pr2_pru1_gpo9	gpio5_24	Driver off
0x1664	CTRL_CORE_PAD_RGMII0_RXD0	U6	rgmii0_txd0	rmii0_rxd0		mii0_rxd0	vin2a_d10				spi4_cs0	uart4_rtsn					pr1_mii0_rxd0	pr2_pru1_gpi10	pr2_pru1_gpo10	gpio5_25	Driver off
0x1668	CTRL_CORE_PAD_RGMII0_RXC	U5	rgmii0_rxc		rmii1_txen	mii0_txclk	vin2a_d5	vin4b_d5									pr1_mii_mt0_clk	pr2_pru1_gpi11	pr2_pru1_gpo11	gpio5_26	Driver off
0x166C	CTRL_CORE_PAD_RGMII0_RXCTL	V5	rgmii0_rxctl		rmii1_txd1	mii0_txd3	vin2a_d6	vin4b_d6									pr1_mii0_txd3	pr2_pru1_gpi12	pr2_pru1_gpo12	gpio5_27	Driver off
0x1670	CTRL_CORE_PAD_RGMII0_RXD3	V4	rgmii0_rxd3		rmii1_txd0	mii0_txd2	vin2a_d7	vin4b_d7									pr1_mii0_txd2	pr2_pru1_gpi13	pr2_pru1_gpo13	gpio5_28	Driver off
0x1674	CTRL_CORE_PAD_RGMII0_RXD2	V3	rgmii0_rxd2	rmii0_txen		mii0_txen	vin2a_d8										pr1_mii0_txen	pr2_pru1_gpi14	pr2_pru1_gpo14	gpio5_29	Driver off
0x1678	CTRL_CORE_PAD_RGMII0_RXD1	Y2	rgmii0_rxd1	rmii0_txd1		mii0_txd1	vin2a_d9										pr1_mii0_txd1	pr2_pru1_gpi15	pr2_pru1_gpo15	gpio5_30	Driver off
0x167C	CTRL_CORE_PAD_RGMII0_RXD0	W2	rgmii0_rxd0	rmii0_txd0		mii0_txd0	vin2a_fld0	vin4b_fld1									pr1_mii0_txd0	pr2_pru1_gpi16	pr2_pru1_gpo16	gpio5_31	Driver off
0x1680	CTRL_CORE_PAD_USB1_DRVBUS	AB10	usb1_drvvbus								timer16									gpio6_12	Driver off
0x1684	CTRL_CORE_PAD_USB2_DRVBUS	AC10	usb2_drvvbus								timer15									gpio6_13	Driver off
0x1688	CTRL_CORE_PAD_GPIO6_14	E21	gpio6_14	mcasp1_axr8	dcan2_txmcan_tx	uart10_rxd					vout2_hsync0	vin4a_hsync0	i2c3_sda	timer1						gpio6_14	Driver off
0x168C	CTRL_CORE_PAD_GPIO6_15	F20	gpio6_15	mcasp1_axr9	dcan2_rxmcan_rx	uart10_txd					vout2_vsync0	vin4a_vsync0	i2c3_scl	timer2						gpio6_15	Driver off
0x1690	CTRL_CORE_PAD_GPIO6_16	F21	gpio6_16	mcasp1_axr10							vout2_fld	vin4a_fld0	clkout1	timer3						gpio6_16	Driver off
0x1694	CTRL_CORE_PAD_XREF_CLK0	D18	xref_clk0	mcasp2_axr8	mcasp1_axr4	mcasp1_ahclkx	mcasp5_ahclkx					hdq0	clkout2	timer13	pr2_mii1_col	pr2_pru1_gpi5	pr2_pru1_gpo5			gpio6_17	Driver off
0x1698	CTRL_CORE_PAD_XREF_CLK1	E17	xref_clk1	mcasp2_axr9	mcasp1_axr5	mcasp2_ahclkx	mcasp6_ahclkx							timer14	pr2_mii1_crs	pr2_pru1_gpi6	pr2_pru1_gpo6			gpio6_18	Driver off
0x169C	CTRL_CORE_PAD_XREF_CLK2	B26	xref_clk2	mcasp2_axr10	mcasp1_axr6	mcasp3_ahclkx	mcasp7_ahclkx				vout2_clk	vin4a_clk0		timer15						gpio6_19	Driver off

**Table 4-33. Pin Multiplexing (continued)**

ADDRESS	REGISTER NAME	BALL NUMBER	MUXMODE FIELD SETTINGS (CTRL_CORE_PAD_*[3:0])															
			0*	1	2*	3	4	5	6	7	8	9	10	11	12	13	14*	15
0x16A0	CTRL_CORE_PAD_XREF_CLK3	C23	xref_clk3	mcasp2_axr11	mcasp1_axr7	mcasp4_ahclkx	mcasp8_ahclkx			vout2_de	hdq0	vin4a_de0	clkout3	timer16			gpio6_20	Driver off
0x16A4	CTRL_CORE_PAD_MCASP1_ACLKX	C14	mcasp1_aclkx										i2c3_sda	pr2_mdio_mdclk	pr2_pru1_gpi7	pr2_pru1_gpo7	gpio7_31	Driver off
0x16A8	CTRL_CORE_PAD_MCASP1_FSX	D14	mcasp1_fsx										i2c3_scl	pr2_mdio_data			gpio7_30	Driver off
0x16AC	CTRL_CORE_PAD_MCASP1_ACLKR	B14	mcasp1_aclkr	mcasp7_axr2						vout2_d0		vin4a_d0	i2c4_sda				gpio5_0	Driver off
0x16B0	CTRL_CORE_PAD_MCASP1_FSR	J14	mcasp1_fsr	mcasp7_axr3						vout2_d1		vin4a_d1	i2c4_scl				gpio5_1	Driver off
0x16B4	CTRL_CORE_PAD_MCASP1_AXR0	G12	mcasp1_axr0			uart6_rxd							i2c5_sda	pr2_mii0_rxer	pr2_pru1_gpi8	pr2_pru1_gpo8	gpio5_2	Driver off
0x16B8	CTRL_CORE_PAD_MCASP1_AXR1	F12	mcasp1_axr1			uart6_txd							i2c5_scl	pr2_mii0_clk	pr2_pru1_gpi9	pr2_pru1_gpo9	gpio5_3	Driver off
0x16BC	CTRL_CORE_PAD_MCASP1_AXR2	G13	mcasp1_axr2	mcasp6_axr2		uart6_ctsn				vout2_d2		vin4a_d2					gpio5_4	Driver off
0x16C0	CTRL_CORE_PAD_MCASP1_AXR3	J11	mcasp1_axr3	mcasp6_axr3		uart6_rtsn				vout2_d3		vin4a_d3					gpio5_5	Driver off
0x16C4	CTRL_CORE_PAD_MCASP1_AXR4	E12	mcasp1_axr4	mcasp4_axr2						vout2_d4		vin4a_d4					gpio5_6	Driver off
0x16C8	CTRL_CORE_PAD_MCASP1_AXR5	F13	mcasp1_axr5	mcasp4_axr3						vout2_d5		vin4a_d5					gpio5_7	Driver off
0x16CC	CTRL_CORE_PAD_MCASP1_AXR6	C12	mcasp1_axr6	mcasp5_axr2						vout2_d6		vin4a_d6					gpio5_8	Driver off
0x16D0	CTRL_CORE_PAD_MCASP1_AXR7	D12	mcasp1_axr7	mcasp5_axr3						vout2_d7		vin4a_d7	timer4				gpio5_9	Driver off
0x16D4	CTRL_CORE_PAD_MCASP1_AXR8	B12	mcasp1_axr8	mcasp6_axr0		spi3_sclk							timer5	pr2_mii0_txen	pr2_pru1_gpi10	pr2_pru1_gpo10	gpio5_10	Driver off
0x16D8	CTRL_CORE_PAD_MCASP1_AXR9	A11	mcasp1_axr9	mcasp6_axr1		spi3_d1							timer6	pr2_mii0_tx_d3	pr2_pru1_gpi11	pr2_pru1_gpo11	gpio5_11	Driver off
0x16DC	CTRL_CORE_PAD_MCASP1_AXR10	B13	mcasp1_axr10	mcasp6_aclkx	mcasp6_aclkr	spi3_d0							timer7	pr2_mii0_tx_d2	pr2_pru1_gpi12	pr2_pru1_gpo12	gpio5_12	Driver off
0x16E0	CTRL_CORE_PAD_MCASP1_AXR11	A12	mcasp1_axr11	mcasp6_fsx	mcasp6_fsr	spi3_cs0							timer8	pr2_mii0_tx_d1	pr2_pru1_gpi13	pr2_pru1_gpo13	gpio4_17	Driver off
0x16E4	CTRL_CORE_PAD_MCASP1_AXR12	E14	mcasp1_axr12	mcasp7_axr0		spi3_cs1							timer9	pr2_mii0_tx_d0	pr2_pru1_gpi14	pr2_pru1_gpo14	gpio4_18	Driver off
0x16E8	CTRL_CORE_PAD_MCASP1_AXR13	A13	mcasp1_axr13	mcasp7_axr1									timer10	pr2_mii0_clk	pr2_pru1_gpi15	pr2_pru1_gpo15	gpio6_4	Driver off
0x16EC	CTRL_CORE_PAD_MCASP1_AXR14	G14	mcasp1_axr14	mcasp7_aclkx	mcasp7_aclkr								timer11	pr2_mii0_rxdv	pr2_pru1_gpi16	pr2_pru1_gpo16	gpio6_5	Driver off
0x16F0	CTRL_CORE_PAD_MCASP1_AXR15	F14	mcasp1_axr15	mcasp7_fsx	mcasp7_fsr								timer12	pr2_mii0_rxd3	pr2_pru0_gpi20	pr2_pru0_gpo20	gpio6_6	Driver off
0x16F4	CTRL_CORE_PAD_MCASP2_ACLKX	A19	mcasp2_aclkx											pr2_mii0_rxd2	pr2_pru0_gpi18	pr2_pru0_gpo18		Driver off
0x16F8	CTRL_CORE_PAD_MCASP2_FSX	A18	mcasp2_fsx											pr2_mii0_rxd1	pr2_pru0_gpi19	pr2_pru0_gpo19		Driver off
0x16FC	CTRL_CORE_PAD_MCASP2_ACLKR	E15	mcasp2_aclkr	mcasp8_axr2						vout2_d8		vin4a_d8						Driver off

**Table 4-33. Pin Multiplexing (continued)**

ADDRESS	REGISTER NAME	BALL NUMBER	MUXMODE FIELD SETTINGS (CTRL_CORE_PAD_*[3:0])																
			0*	1	2*	3	4	5	6	7	8	9	10	11	12	13	14*	15	
0x1700	CTRL_CORE_PAD_MCASP2_FSR	A20	mcasp2_fsr	mcasp8_axr3						vout2_d9		vin4a_d9							Driver off
0x1704	CTRL_CORE_PAD_MCASP2_AXR0	B15	mcasp2_axr0							vout2_d10		vin4a_d10							Driver off
0x1708	CTRL_CORE_PAD_MCASP2_AXR1	A15	mcasp2_axr1							vout2_d11		vin4a_d11							Driver off
0x170C	CTRL_CORE_PAD_MCASP2_AXR2	C15	mcasp2_axr2	mcasp3_axr2										pr2_mii0_rx_d0	pr2_pru0_gpi16	pr2_pru0_gpo16	gpio6_8	Driver off	
0x1710	CTRL_CORE_PAD_MCASP2_AXR3	A16	mcasp2_axr3	mcasp3_axr3										pr2_mii0_rxlink	pr2_pru0_gpi17	pr2_pru0_gpo17	gpio6_9	Driver off	
0x1714	CTRL_CORE_PAD_MCASP2_AXR4	D15	mcasp2_axr4	mcasp8_axr0						vout2_d12		vin4a_d12					gpio1_4	Driver off	
0x1718	CTRL_CORE_PAD_MCASP2_AXR5	B16	mcasp2_axr5	mcasp8_axr1						vout2_d13		vin4a_d13					gpio6_7	Driver off	
0x171C	CTRL_CORE_PAD_MCASP2_AXR6	B17	mcasp2_axr6	mcasp8_aclkr	mcasp8_aclkr					vout2_d14		vin4a_d14					gpio2_29	Driver off	
0x1720	CTRL_CORE_PAD_MCASP2_AXR7	A17	mcasp2_axr7	mcasp8_fsx	mcasp8_fsr					vout2_d15		vin4a_d15					gpio1_5	Driver off	
0x1724	CTRL_CORE_PAD_MCASP3_ACLKX	B18	mcasp3_aclkr	mcasp3_aclkr	mcasp2_axr12	uart7_rxd								pr2_mii0_crs	pr2_pru0_gpi12	pr2_pru0_gpo12	gpio5_13	Driver off	
0x1728	CTRL_CORE_PAD_MCASP3_FSX	F15	mcasp3_fsx	mcasp3_fsr	mcasp2_axr13	uart7_txd								pr2_mii0_col	pr2_pru0_gpi13	pr2_pru0_gpo13	gpio5_14	Driver off	
0x172C	CTRL_CORE_PAD_MCASP3_AXR0	B19	mcasp3_axr0		mcasp2_axr14	uart7_ctsn	uart5_rxd							pr2_mii1_rxer	pr2_pru0_gpi14	pr2_pru0_gpo14		Driver off	
0x1730	CTRL_CORE_PAD_MCASP3_AXR1	C17	mcasp3_axr1		mcasp2_axr15	uart7_rtsn	uart5_txd							pr2_mii1_rxlink	pr2_pru0_gpi15	pr2_pru0_gpo15		Driver off	
0x1734	CTRL_CORE_PAD_MCASP4_ACLKX	C18	mcasp4_aclkr	mcasp4_aclkr	spi3_sclk	uart8_rxd	i2c4_sda			vout2_d16		vin4a_d16						Driver off	
0x1738	CTRL_CORE_PAD_MCASP4_FSX	A21	mcasp4_fsx	mcasp4_fsr	spi3_d1	uart8_txd	i2c4_scl			vout2_d17		vin4a_d17						Driver off	
0x173C	CTRL_CORE_PAD_MCASP4_AXR0	G16	mcasp4_axr0		spi3_d0	uart8_ctsn	uart4_rxd			vout2_d18		vin4a_d18						Driver off	
0x1740	CTRL_CORE_PAD_MCASP4_AXR1	D17	mcasp4_axr1		spi3_cs0	uart8_rtsn	uart4_txd			vout2_d19		vin4a_d19			pr2_pru1_gpi0	pr2_pru1_gpo0		Driver off	
0x1744	CTRL_CORE_PAD_MCASP5_ACLKX	AA3	mcasp5_aclkr	mcasp5_aclkr	spi4_sclk	uart9_rxd	i2c5_sda			vout2_d20		vin4a_d20			pr2_pru1_gpi1	pr2_pru1_gpo1		Driver off	
0x1748	CTRL_CORE_PAD_MCASP5_FSX	AB9	mcasp5_fsx	mcasp5_fsr	spi4_d1	uart9_txd	i2c5_scl			vout2_d21		vin4a_d21			pr2_pru1_gpi2	pr2_pru1_gpo2		Driver off	
0x174C	CTRL_CORE_PAD_MCASP5_AXR0	AB3	mcasp5_axr0		spi4_d0	uart9_ctsn	uart3_rxd			vout2_d22		vin4a_d22		pr2_mdio_mdclk	pr2_pru1_gpi3	pr2_pru1_gpo3		Driver off	
0x1750	CTRL_CORE_PAD_MCASP5_AXR1	AA4	mcasp5_axr1		spi4_cs0	uart9_rtsn	uart3_txd			vout2_d23		vin4a_d23		pr2_mdio_data	pr2_pru1_gpi4	pr2_pru1_gpo4		Driver off	
0x1754	CTRL_CORE_PAD_MMC1_CLK	W6	mmc1_clk														gpio6_21	Driver off	
0x1758	CTRL_CORE_PAD_MMC1_CMD	Y6	mmc1_cmd														gpio6_22	Driver off	
0x175C	CTRL_CORE_PAD_MMC1_DAT0	AA6	mmc1_dat0														gpio6_23	Driver off	



**Table 4-33. Pin Multiplexing (continued)**

ADDRESS	REGISTER NAME	BALL NUMBER	MUXMODE FIELD SETTINGS (CTRL_CORE_PAD_*[3:0])																
			0*	1	2*	3	4	5	6	7	8	9	10	11	12	13	14*	15	
0x1760	CTRL_CORE_PAD_MMC1_DAT1	Y4	mmc1_dat1															gpio6_24	Driver off
0x1764	CTRL_CORE_PAD_MMC1_DAT2	AA5	mmc1_dat2															gpio6_25	Driver off
0x1768	CTRL_CORE_PAD_MMC1_DAT3	Y3	mmc1_dat3															gpio6_26	Driver off
0x176C	CTRL_CORE_PAD_MMC1_SDCD	W7	mmc1_sdc			uart6_rxd	i2c4_sda											gpio6_27	Driver off
0x1770	CTRL_CORE_PAD_MMC1_SDWP	Y9	mmc1_sdw p			uart6_txd	i2c4_scl											gpio6_28	Driver off
0x1774	CTRL_CORE_PAD_GPIO6_10	AC5	gpio6_10	mdio_mclk	i2c3_sda		vin2b_hsyn c1							ehrpwm2A	pr2_mii_mt 1_clk	pr2_pru0_g pi0	pr2_pru0_g po0	gpio6_10	Driver off
0x1778	CTRL_CORE_PAD_GPIO6_11	AB4	gpio6_11	mdio_d	i2c3_scl		vin2b_vsyn c1							ehrpwm2B	pr2_mii1_tx en	pr2_pru0_g pi1	pr2_pru0_g po1	gpio6_11	Driver off
0x177C	CTRL_CORE_PAD_MMC3_CLK	AD4	mmc3_clk				vin2b_d7							ehrpwm2_tr ipzone_inpu t	pr2_mii1_tx d3	pr2_pru0_g pi2	pr2_pru0_g po2	gpio6_29	Driver off
0x1780	CTRL_CORE_PAD_MMC3_CMD	AC4	mmc3_cmd	spi3_sclk			vin2b_d6							eCAP2_in_ PWM2_out	pr2_mii1_tx d2	pr2_pru0_g pi3	pr2_pru0_g po3	gpio6_30	Driver off
0x1784	CTRL_CORE_PAD_MMC3_DAT0	AC7	mmc3_dat0	spi3_d1	uart5_rxd		vin2b_d5							eQEP3A_in	pr2_mii1_tx d1	pr2_pru0_g pi4	pr2_pru0_g po4	gpio6_31	Driver off
0x1788	CTRL_CORE_PAD_MMC3_DAT1	AC6	mmc3_dat1	spi3_d0	uart5_txd		vin2b_d4							eQEP3B_in	pr2_mii1_tx d0	pr2_pru0_g pi5	pr2_pru0_g po5	gpio7_0	Driver off
0x178C	CTRL_CORE_PAD_MMC3_DAT2	AC9	mmc3_dat2	spi3_cs0	uart5_ctsn		vin2b_d3							eQEP3_ind ex	pr2_mii_mr 1_clk	pr2_pru0_g pi6	pr2_pru0_g po6	gpio7_1	Driver off
0x1790	CTRL_CORE_PAD_MMC3_DAT3	AC3	mmc3_dat3	spi3_cs1	uart5_rtsn		vin2b_d2							eQEP3_str obe	pr2_mii1_rx dv	pr2_pru0_g pi7	pr2_pru0_g po7	gpio7_2	Driver off
0x1794	CTRL_CORE_PAD_MMC3_DAT4	AC8	mmc3_dat4	spi4_sclk	uart10_rxd		vin2b_d1							ehrpwm3A	pr2_mii1_rx d3	pr2_pru0_g pi8	pr2_pru0_g po8	gpio1_22	Driver off
0x1798	CTRL_CORE_PAD_MMC3_DAT5	AD6	mmc3_dat5	spi4_d1	uart10_txd		vin2b_d0							ehrpwm3B	pr2_mii1_rx d2	pr2_pru0_g pi9	pr2_pru0_g po9	gpio1_23	Driver off
0x179C	CTRL_CORE_PAD_MMC3_DAT6	AB8	mmc3_dat6	spi4_d0	uart10_ctsn		vin2b_de1							ehrpwm3_tr ipzone_inpu t	pr2_mii1_rx d1	pr2_pru0_g pi10	pr2_pru0_g po10	gpio1_24	Driver off
0x17A0	CTRL_CORE_PAD_MMC3_DAT7	AB5	mmc3_dat7	spi4_cs0	uart10_rtsn		vin2b_clk1							eCAP3_in_ PWM3_out	pr2_mii1_rx d0	pr2_pru0_g pi11	pr2_pru0_g po11	gpio1_25	Driver off
0x17A4	CTRL_CORE_PAD_SPI1_SCLK	A25	spi1_sclk															gpio7_7	Driver off
0x17A8	CTRL_CORE_PAD_SPI1_D1	F16	spi1_d1															gpio7_8	Driver off
0x17AC	CTRL_CORE_PAD_SPI1_D0	B25	spi1_d0															gpio7_9	Driver off
0x17B0	CTRL_CORE_PAD_SPI1_CS0	A24	spi1_cs0															gpio7_10	Driver off
0x17B4	CTRL_CORE_PAD_SPI1_CS1	A22	spi1_cs1		sata1_led	spi2_cs1												gpio7_11	Driver off
0x17B8	CTRL_CORE_PAD_SPI1_CS2	B21	spi1_cs2	uart4_rxd	mmc3_sdc	spi2_cs2	dcan2_tx	mdio_mclk	hdmi1_hpd									gpio7_12	Driver off

**Table 4-33. Pin Multiplexing (continued)**

ADDRESS	REGISTER NAME	BALL NUMBER	MUXMODE FIELD SETTINGS (CTRL_CORE_PAD_*[3:0])															
			0*	1	2*	3	4	5	6	7	8	9	10	11	12	13	14*	15
0x17BC	CTRL_CORE_PAD_SPI1_CS3	B20	spi1_cs3	uart4_txd	mmc3_sdw p	spi2_cs3	dcan2_rx	mdio_d	hdmi1_cec								gpio7_13	Driver off
0x17C0	CTRL_CORE_PAD_SPI2_SCLK	A26	spi2_sclk	uart3_rxd													gpio7_14	Driver off
0x17C4	CTRL_CORE_PAD_SPI2_D1	B22	spi2_d1	uart3_txd													gpio7_15	Driver off
0x17C8	CTRL_CORE_PAD_SPI2_D0	G17	spi2_d0	uart3_ctsn	uart5_rxd												gpio7_16	Driver off
0x17CC	CTRL_CORE_PAD_SPI2_CS0	B24	spi2_cs0	uart3_rtsn	uart5_txd												gpio7_17	Driver off
0x17E0	CTRL_CORE_PAD_UART1_RXD	B27	uart1_rxd			mmc4_sdccl											gpio7_22	Driver off
0x17E4	CTRL_CORE_PAD_UART1_TXD	C26	uart1_txd			mmc4_sdw p											gpio7_23	Driver off
0x17E8	CTRL_CORE_PAD_UART1_CTSN	E25	uart1_ctsn		uart9_rxd	mmc4_clk											gpio7_24	Driver off
0x17EC	CTRL_CORE_PAD_UART1_RTSN	C27	uart1_rtsn		uart9_txd	mmc4_cmd											gpio7_25	Driver off
0x17F0	CTRL_CORE_PAD_UART2_RXD	D28		uart3_ctsn	uart3_rctx	mmc4_dat0	uart2_rxd	uart1_dcdn									gpio7_26	Driver off
0x17F4	CTRL_CORE_PAD_UART2_TXD	D26	uart2_txd	uart3_rtsn	uart3_sd	mmc4_dat1	uart2_txd	uart1_dsrn									gpio7_27	Driver off
0x17F8	CTRL_CORE_PAD_UART2_CTSN	D27	uart2_ctsn		uart3_rxd	mmc4_dat2	uart10_rxd	uart1_dtrn									gpio1_16	Driver off
0x17FC	CTRL_CORE_PAD_UART2_RTSN	C28	uart2_rtsn	uart3_txd	uart3_irtx	mmc4_dat3	uart10_txd	uart1_rin									gpio1_17	Driver off
0x1800	CTRL_CORE_PAD_I2C1_SDA	C21	i2c1_sda															
0x1804	CTRL_CORE_PAD_I2C1_SCL	C20	i2c1_scl															
0x1808	CTRL_CORE_PAD_I2C2_SDA	C25	i2c2_sda	hdmi1_ddc_scl														Driver off
0x180C	CTRL_CORE_PAD_I2C2_SCL	F17	i2c2_scl	hdmi1_ddc_sda														Driver off
0x1818	CTRL_CORE_PAD_WAKEUP0	AD17	Wakeup0	dcan1_rx													gpio1_0	Driver off
0x181C	CTRL_CORE_PAD_WAKEUP1	AC17	Wakeup1	dcan2_rx													gpio1_1	Driver off
0x1820	CTRL_CORE_PAD_WAKEUP2	AB16	Wakeup2	sys_nirq2													gpio1_2	Driver off
0x1824	CTRL_CORE_PAD_WAKEUP3	AC16	Wakeup3	sys_nirq1													gpio1_3	Driver off
0x1828	CTRL_CORE_PAD_ON_OFF	Y11	on_off															
0x182C	CTRL_CORE_PAD_RTC_PORZ	AB17	rtc_porz															
0x1830	CTRL_CORE_PAD_TMS	F18	tms															

**Table 4-33. Pin Multiplexing (continued)**

ADDRESS	REGISTER NAME	BALL NUMBER	MUXMODE FIELD SETTINGS (CTRL_CORE_PAD_*[3:0])																
			0*	1	2*	3	4	5	6	7	8	9	10	11	12	13	14*	15	
0x1834	CTRL_CORE_PAD_TDI	D23	tdi															gpio8_27	
0x1838	CTRL_CORE_PAD_TDO	F19	tdo															gpio8_28	
0x183C	CTRL_CORE_PAD_TCLK	E20	tclk																
0x1840	CTRL_CORE_PAD_TRSTN	D20	trstn																
0x1844	CTRL_CORE_PAD_RTCK	E18	rtck															gpio8_29	
0x1848	CTRL_CORE_PAD_EMU0	G21	emu0															gpio8_30	
0x184C	CTRL_CORE_PAD_EMU1	D24	emu1															gpio8_31	
0x185C	CTRL_CORE_PAD_RESETN	E23	resetn																
0x1860	CTRL_CORE_PAD_NMIN_DSP	D21	nmin_dsp																
0x1864	CTRL_CORE_PAD_RSTOUTN	F23	rstoutn																

1. NA stands for Not Applicable.

## 4.5 Connections for Unused Pins

This section describes the Unused/Reserved balls connection requirements.

---

### NOTE

The following balls are reserved: Y5 / Y10 / B28 / A27

These balls must be left unconnected.

---

### NOTE

All unused power supply balls must be supplied with the voltages specified in the [Section 5.4, Recommended Operating Conditions](#), unless alternative tie-off options are included in [Section 4.3, Signal Descriptions](#).

---

**Table 4-34. Unused Balls Specific Connection Requirements**

BALLS	CONNECTION REQUIREMENTS
<a href="#">AE14</a> / <a href="#">AE15</a> / <a href="#">AD17</a> / <a href="#">AC15</a> / <a href="#">AC16</a> / <a href="#">AC17</a> / <a href="#">AB16</a> / <a href="#">V27</a> / <a href="#">D20</a> / <a href="#">AH25</a> / <a href="#">AE27</a> / <a href="#">AD27</a> / <a href="#">Y28</a> / <a href="#">G28</a> / <a href="#">H27</a> / <a href="#">K27</a> / <a href="#">M28</a>	These balls must be connected to GND through an external pull resistor if unused
<a href="#">V28</a> / <a href="#">F18</a> / <a href="#">E20</a> / <a href="#">E23</a> / <a href="#">D21</a> / <a href="#">C20</a> / <a href="#">C21</a> / <a href="#">AG25</a> / <a href="#">AE28</a> / <a href="#">AD28</a> / <a href="#">Y27</a> / <a href="#">G27</a> / <a href="#">H28</a> / <a href="#">K28</a> / <a href="#">M27</a> / <a href="#">F17</a> / <a href="#">C25</a>	These balls must be connected to the corresponding power supply through an external pull resistor if unused
<a href="#">AF14</a> (rtc_iso)	This ball should be connected to the corresponding power supply through an external pull resistor if unused; or can be connected to F22 (porz) when RTC unused (level translation may be needed)
<a href="#">AB17</a> (rtc_porz)	This ball should be connected to VSS when RTC is unused; or can be connected to F22 (porz) when RTC unused (level translation may be needed)
<a href="#">K14</a> (vpp)	This ball must be left unconnected if unused

---

### NOTE

All other unused signal balls **with** a Pad Configuration Register can be left unconnected with their internal pullup or pulldown resistor enabled.

---

### NOTE

All other unused signal balls **without** a Pad Configuration Register can be left unconnected.

---

## 5 Specifications

---

### NOTE

For more information, see the *Power, Reset, and Clock Management / PRCM Subsystem Environment / External Voltage Inputs or Initialization / Preinitialization / Power Requirements* section in the device TRM.

---

### NOTE

The index numbers 1 and 2 which is part of the EMIF1 and EMIF2 signal prefixes (ddr1\_\* and ddr2\_\*) listed in [Table 4-5, EMIF Signal Descriptions](#), column "SIGNAL NAME" not to be confused with DDR1 and DDR2 types of SDRAM memories.

---

### NOTE

Audio Back End (ABE) module is not supported for this family of devices, but "ABE" name is still present in some clock or DPLL names.

---

### CAUTION

All IO cells are NOT Fail-safe compliant and should not be externally driven in absence of their IO supply.

## 5.1 Absolute Maximum Ratings

over operating free-air temperature range (unless otherwise noted) <sup>(1)</sup>

PARAMETER <sup>(1)</sup>		MIN	MAX	UNIT
V <sub>SUPPLY</sub> (Steady-State)	Core (vdd, vdd_mpu, vdd_gpu, vdd_dspeve, vdd_iva, vdd_rtc)	-0.3	1.5	V
	Analog (vdda_usb1, vdda_usb2, vdda_abe_per, vdda_ddr, vdda_debug, vdda_dsp_eve, vdda_gmac_core, vdda_gpu, vdda_hdmi, vdda_iva, vdda_pcie, vdda_pcie0, vdda_pcie1, vdda_sata, vdda_usb3, vdda_video, vdda_mpu, vdda_osc, vdda_rtc)	-0.3	2.0	
	Analog 3.3V (vdda33v_usb1, vdda33v_usb2)	-0.3	3.8	
	vdds18v, vdds18v_ddr1, vdds18v_ddr2, vdds_mlbp, vdds_ddr1, vdds_ddr2	-0.3	2.1	
	vddshv1-11 (1.8V mode)	-0.3	2.1	
	vddshv1-7 (3.3V mode), vddshv9-11 (3.3V mode)	-0.3	3.8	
	vddshv8 (3.3V mode)	-0.3	3.6	
	V <sub>IO</sub> (Steady-State)	Core I/Os	-0.3	1.5
Analog I/Os (except HDMI)		-0.3	2.0	
HDMI I/Os		-0.3	3.5	
I/O 1.35 V		-0.3	1.65	
I/O 1.5 V		-0.3	1.8	
1.8 V I/Os		-0.3	2.1	
3.3 V I/Os (except those powered by vddshv8)		-0.3	3.8	
3.3 V I/Os (powered by vddshv8)		-0.3	3.6	
SR	Maximum slew rate, all supplies		10 <sup>5</sup>	V/s
V <sub>IO</sub> (Transient Overshoot / Undershoot)	Input and Output Voltage Ranges (Transient Overshoot/Undershoot) Note: valid for up to 20% of the signal period. See <a href="#">Figure 5-1, IO transient voltage ranges</a>		0.2 × VDD <sup>(3)</sup>	V
T <sub>STG</sub>	Storage temperature range after soldered onto PC Board	-55	+150	°C
Latch-up I-Test	I-test <sup>(4)</sup> , All I/Os (if different levels then one line per level)	-100	100	mA
Latch-up OV-Test	Over-voltage Test <sup>(5)</sup> , All supplies (if different levels then one line per level)	N/A	1.5 × V <sub>SUPPLY</sub> MAX	V

(1) Stresses beyond those listed as absolute maximum ratings may cause permanent damage to the device. These are stress ratings only, and functional operation of the device at these or any other conditions beyond those listed under [Section 5.4, Recommended Operating Conditions](#), is not implied. Exposure to absolute maximum rated conditions for extended periods may affect device reliability.

(2) See I/Os supplied by this power pin in [Table 4-1, Pin Attributes](#).

(3) VDD is the voltage on the corresponding power-supply pin(s) for the IO.

(4) Per JEDEC JESD78 at 125°C with specified I/O pin injection current and clamp voltage of 1.5 times maximum recommended I/O voltage and negative 0.5 times maximum recommended I/O voltage.

(5) Per JEDEC JESD78 at 125°C.

(6) The maximum valid input voltage on an IO pin cannot exceed 0.3 volts when the supply powering the IO is turned off. This requirement applies to all the IO pins which are not fail-safe and for all values of IO supply voltage. Special attention should be applied anytime peripheral devices are not powered from the same power sources used to power the respective IO supply. It is important the attached peripheral never sources a voltage outside the valid input voltage range, including power supply ramp-up and ramp-down sequences.

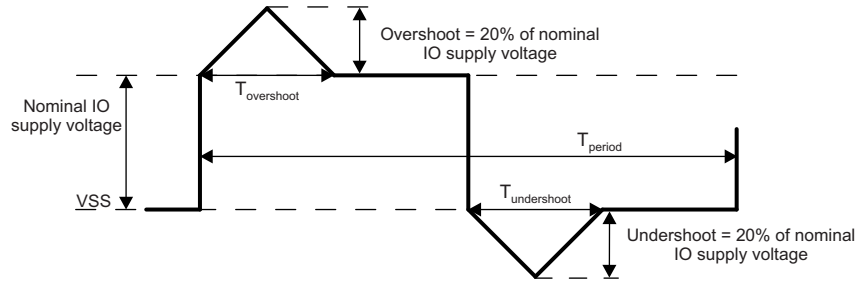

osus\_sprs851

(1)  $T_{overshoot} + T_{undershoot} < 20\% \text{ of } T_{period}$

**Figure 5-1. IO Transient Voltage Ranges**

## 5.2 ESD Ratings

		VALUE	UNIT
V <sub>ESD</sub> Electrostatic discharge	Human-body model (HBM), per ANSI/ESDA/JEDEC JS-001 <sup>(1)</sup>	±1000	V
	Charged-device model (CDM), per JEDEC specification JESD22-C101 <sup>(2)</sup>	±250	

(1) JEDEC document JEP155 states that 500-V HBM allows safe manufacturing with a standard ESD control process.

(2) JEDEC document JEP157 states that 250-V CDM allows safe manufacturing with a standard ESD control process.

## 5.3 Power-On Hours (POH) Limits

The information in the section below is provided solely for your convenience and does not extend or modify the warranty provided under TI's standard terms and conditions for TI semiconductor products.

### NOTE

POH is a function of voltage, temperature and time. Usage at higher voltages and temperatures will result in a reduction in POH.

**Table 5-1. Power-On Hours (POH) Limits<sup>(1)</sup>**

OPERATING CONDITION		COMMERCIAL JUNCTION TEMP RANGE 0°C ~ 90°C		EXTENDED JUNCTION TEMP RANGE -40°C ~ 105°C			
Operating Performance Point (OPP)	HDMI	JUNCTION TEMP (Tj)	LIFETIME (POH)	JUNCTION TEMP (Tj)	LIFETIME (POH)	JUNCTION TEMP (Tj)	LIFETIME (POH)
OPP_NOM or OPP_OD	Not Used	90°C	100k	100°C	100k	105°C	100k <sup>(3)</sup>
	Used <sup>(2)</sup>	90°C	100k	100°C	63k	105°C	45k
OPP_HIGH	Not Used	90°C	65k	100°C	55k	105°C	50k
	Used <sup>(2)</sup>	90°C	65k	100°C	55k	105°C	45k

(1) Unless specified in [Table 5-1](#), all voltage domains and operating conditions are supported in the device at the noted temperatures.

(2) Power-On Hours (POH) assume HDMI is used at the maximum supported bit rate continuously and/or operating the device continuously at the VD\_MPU operating point (OPP) noted.

(3) 90k POH only if SuperSpeed USB 3.0 Dual-Role-Device (at 5 Gbps) or PCIe in Gen-II mode (at 5 Gbps) are used.

## 5.4 Recommended Operating Conditions<sup>(4)</sup>

over operating free-air temperature range (unless otherwise noted)

PARAMETER	DESCRIPTION	MIN <sup>(2)</sup>	NOM	MAX DC <sup>(3)</sup>	MAX <sup>(2)</sup>	UNIT
<b>Input Power Supply Voltage Range</b>						
vdd	Core voltage domain supply		See <a href="#">Section 5.5</a>			V
vdd_mpu	Supply voltage range for MPU domain		See <a href="#">Section 5.5</a>			V
vdd_gpu	GPU voltage domain supply		See <a href="#">Section 5.5</a>			V
vdd_dspeve	DSP voltage domain supply		See <a href="#">Section 5.5</a>			V
vdd_iva	IVA voltage domain supply		See <a href="#">Section 5.5</a>			V
vdd_rtc	RTC voltage domain supply		See <a href="#">Section 5.5</a>			V
vdda_usb1	DPLL_USB and HS USB1 1.8 V analog power supply	1.71	1.80	1.836	1.89	V
	Maximum noise (peak-peak)		50			mV <sub>PPmax</sub>
vdda_usb2	HS USB2 1.8 V analog power supply	1.71	1.80	1.836	1.89	V
	Maximum noise (peak-peak)		50			mV <sub>PPmax</sub>



## Recommended Operating Conditions<sup>(4)</sup> (continued)

over operating free-air temperature range (unless otherwise noted)

PARAMETER	DESCRIPTION	MIN <sup>(2)</sup>	NOM	MAX DC <sup>(3)</sup>	MAX <sup>(2)</sup>	UNIT
vdda33v_usb1	HS USB1 3.3 V analog power supply. If USB1 is not used, this pin can alternatively be connected to VSS if the following requirements are met: - The usb1_dm/usb1_dp pins are left unconnected - The USB1 PHY is kept powered down	3.135	3.3	3.366	3.465	V
	Maximum noise (peak-peak)		50			mV <sub>PPmax</sub>
vdda33v_usb2	HS USB2 3.3 V analog power supply. If USB2 is not used, this pin can alternatively be connected to VSS if the following requirements are met: - The usb2_dm/usb2_dp pins are left unconnected - The USB2 PHY is kept powered down	3.135	3.3	3.366	3.465	V
	Maximum noise (peak-peak)		50			mV <sub>PPmax</sub>
vdda_abe_per	DPLL_ABE, DPLL_PER, and PER HSDIVIDER analog power supply	1.71	1.80	1.836	1.89	V
	Maximum noise (peak-peak)		50			mV <sub>PPmax</sub>
vdda_dds	DPLL_DDR and DDR HSDIVIDER analog power supply	1.71	1.80	1.836	1.89	V
	Maximum noise (peak-peak)		50			mV <sub>PPmax</sub>
vdda_debug	DPLL_DEBUG analog power supply	1.71	1.80	1.836	1.89	V
	Maximum noise (peak-peak)		50			mV <sub>PPmax</sub>
vdda_dsp_eve	DPLL_DSP analog power supply	1.71	1.80	1.836	1.89	V
	Maximum noise (peak-peak)		50			mV <sub>PPmax</sub>
vdda_gmac_core	DPLL_CORE and CORE HSDIVIDER analog power supply	1.71	1.80	1.836	1.89	V
	Maximum noise (peak-peak)		50			mV <sub>PPmax</sub>
vdda_gpu	DPLL_GPU analog power supply	1.71	1.80	1.836	1.89	V
	Maximum noise (peak-peak)		50			mV <sub>PPmax</sub>
vdda_hdmi	PLL_HDMI and HDMI analog power supply	1.71	1.80	1.836	1.89	V
	Maximum noise (peak-peak)		50			mV <sub>PPmax</sub>
vdda_iva	DPLL_IVA analog power supply	1.71	1.80	1.836	1.89	V
	Maximum noise (peak-peak)		50			mV <sub>PPmax</sub>
vdda_pcie	DPLL_PCIE_REF and PCIe analog power supply	1.71	1.80	1.836	1.89	V
	Maximum noise (peak-peak)		50			mV <sub>PPmax</sub>
vdda_pcie0	PCIe ch0 RX/TX analog power supply	1.71	1.80		1.89	V
	Maximum noise (peak-peak)		50			mV <sub>PPmax</sub>
vdda_pcie1	PCIe ch1 RX/TX analog power supply	1.71	1.80		1.89	V
	Maximum noise (peak-peak)		50			mV <sub>PPmax</sub>
vdda_sata	DPLL_SATA and SATA RX/TX analog power supply	1.71	1.80	1.836	1.89	V
	Maximum noise (peak-peak)		50			mV <sub>PPmax</sub>
vdda_usb3	DPLL_USB_OTG_SS and USB3.0 RX/TX analog power supply	1.71	1.80	1.836	1.89	V
	Maximum noise (peak-peak)		50			mV <sub>PPmax</sub>

## Recommended Operating Conditions<sup>(4)</sup> (continued)

over operating free-air temperature range (unless otherwise noted)

PARAMETER	DESCRIPTION	MIN <sup>(2)</sup>	NOM	MAX DC <sup>(3)</sup>	MAX <sup>(2)</sup>	UNIT	
vdda_video	DPLL_VIDEO1 and DPLL_VIDEO2 analog power supply	1.71	1.80	1.836	1.89	V	
	Maximum noise (peak-peak)		50			mV <sub>PPmax</sub>	
vdda_mpu	DPLL_MPU analog power supply	1.71	1.80	1.836	1.89	V	
	Maximum noise (peak-peak)		50			mV <sub>PPmax</sub>	
vdda_osc	HFOSC analog power supply	1.71	1.80		1.89	V	
	Maximum noise (peak-peak)		50			mV <sub>PPmax</sub>	
vdda_rtc	RTC bias and RTC LFOSC analog power supply	1.71	1.80		1.89	V	
	Maximum noise (peak-peak)		50			mV <sub>PPmax</sub>	
vdds18v	1.8 V power supply	1.71	1.80	1.836	1.89	V	
	Maximum noise (peak-peak)		50			mV <sub>PPmax</sub>	
vdds18v_dds1	EMIF1 bias power supply	1.71	1.80	1.836	1.89	V	
	Maximum noise (peak-peak)		50			mV <sub>PPmax</sub>	
vdds18v_dds2	EMIF2 bias power supply	1.71	1.80	1.836	1.89	V	
	Maximum noise (peak-peak)		50			mV <sub>PPmax</sub>	
vdds_dds1	EMIF1 power supply (1.5 V for DDR3 mode / 1.35 V for DDR3L mode)	1.35-V Mode	1.28	1.35	1.377	1.42	V
		1.5-V Mode	1.43	1.50	1.53	1.57	
	Maximum noise (peak-peak)	1.35-V Mode		50			mV <sub>PPmax</sub>
		1.5-V Mode					
vdds_dds2	EMIF2 power supply (1.5 V for DDR3 mode / 1.35 V for DDR3L mode)	1.35-V Mode	1.28	1.35	1.377	1.42	V
		1.5-V Mode	1.43	1.50	1.53	1.57	
	Maximum noise (peak-peak)	1.35-V Mode		50			mV <sub>PPmax</sub>
		1.5-V Mode					
vddshv5	Dual Voltage (1.8 V or 3.3 V) power supply for the INTC Power Group pins	1.8-V Mode	1.71	1.80	1.836	1.89	V
		3.3-V Mode	3.135	3.30	3.366	3.465	
	Maximum noise (peak-peak)	1.8-V Mode		50			mV <sub>PPmax</sub>
		3.3-V Mode					
vddshv1	Dual Voltage (1.8 V or 3.3 V) power supply for the VIN2 Power Group pins	1.8-V Mode	1.71	1.80	1.836	1.89	V
		3.3-V Mode	3.135	3.30	3.366	3.465	
	Maximum noise (peak-peak)	1.8-V Mode		50			mV <sub>PPmax</sub>
		3.3-V Mode					
vddshv10	Dual Voltage (1.8 V or 3.3 V) power supply for the GPMC Power Group pins	1.8-V Mode	1.71	1.80	1.836	1.89	V
		3.3-V Mode	3.135	3.30	3.366	3.465	
	Maximum noise (peak-peak)	1.8-V Mode		50			mV <sub>PPmax</sub>
		3.3-V Mode					
vddshv11	Dual Voltage (1.8 V or 3.3 V) power supply for the MMC2 Power Group pins	1.8-V Mode	1.71	1.80	1.836	1.89	V
		3.3-V Mode	3.135	3.30	3.366	3.465	
	Maximum noise (peak-peak)	1.8-V Mode		50			mV <sub>PPmax</sub>
		3.3-V Mode					

## Recommended Operating Conditions<sup>(4)</sup> (continued)

over operating free-air temperature range (unless otherwise noted)

PARAMETER	DESCRIPTION		MIN <sup>(2)</sup>	NOM	MAX DC <sup>(3)</sup>	MAX <sup>(2)</sup>	UNIT
vddshv2	Dual Voltage (1.8 V or 3.3 V) power supply for the VOUT Power Group pins	1.8-V Mode	1.71	1.80	1.836	1.89	V
		3.3-V Mode	3.135	3.30	3.366	3.465	
	Maximum noise (peak-peak)	1.8-V Mode	50				mV <sub>PPmax</sub>
		3.3-V Mode					
vddshv3	Dual Voltage (1.8 V or 3.3 V) power supply for the GENERAL Power Group pins	1.8-V Mode	1.71	1.80	1.836	1.89	V
		3.3-V Mode	3.135	3.30	3.366	3.465	
	Maximum noise (peak-peak)	1.8-V Mode	50				mV <sub>PPmax</sub>
		3.3-V Mode					
vddshv4	Dual Voltage (1.8 V or 3.3 V) power supply for the MMC4 Power Group pins	1.8-V Mode	1.71	1.80	1.836	1.89	V
		3.3-V Mode	3.135	3.30	3.366	3.465	
	Maximum noise (peak-peak)	1.8-V Mode	50				mV <sub>PPmax</sub>
		3.3-V Mode					
vddshv6	Dual Voltage (1.8 V or 3.3 V) power supply for the VIN1 Power Group pins	1.8-V Mode	1.71	1.80	1.836	1.89	V
		3.3-V Mode	3.135	3.30	3.366	3.465	
	Maximum noise (peak-peak)	1.8-V Mode	50				mV <sub>PPmax</sub>
		3.3-V Mode					
vddshv7	Dual Voltage (1.8 V or 3.3 V) power supply for the WIFI Power Group pins	1.8-V Mode	1.71	1.80	1.836	1.89	V
		3.3-V Mode	3.135	3.30	3.366	3.465	
	Maximum noise (peak-peak)	1.8-V Mode	50				mV <sub>PPmax</sub>
		3.3-V Mode					
vddshv8	Dual Voltage (1.8 V or 3.3 V) power supply for the MMC1 Power Group pins	1.8-V Mode	1.71	1.80	1.836	1.89	V
		3.3-V Mode	3.135	3.30	3.366	3.465	
	Maximum noise (peak-peak)	1.8-V Mode	50				mV <sub>PPmax</sub>
		3.3-V Mode					
vddshv9	Dual Voltage (1.8 V or 3.3 V) power supply for the RGMII Power Group pins	1.8-V Mode	1.71	1.80	1.836	1.89	V
		3.3-V Mode	3.135	3.30	3.366	3.465	
	Maximum noise (peak-peak)	1.8-V Mode	50				mV <sub>PPmax</sub>
		3.3-V Mode					
vss	Ground supply					0	V
vssa_osc0	OSC0 analog ground					0	V
vssa_osc1	OSC1 analog ground					0	V
T <sub>J</sub>	Operating junction temperature range	Commercial	0			90	°C
		Extended	-40			105	
ddr1_vref0	Reference Power Supply for EMIF1		0.5 × vdds_ddr1				V
ddr2_vref0	Reference Power Supply for EMIF2		0.5 × vdds_ddr2				V

(1) Refer to [Table 5-1](#) for limitations.

(2) The voltage at the device ball should never be below the MIN voltage or above the MAX voltage for any amount of time. This requirement includes dynamic voltage events such as AC ripple, voltage transients, voltage dips, etc.

(3) The DC voltage at the device ball should never be above the MAX DC voltage to avoid impact on device reliability and lifetime POH

## Recommended Operating Conditions<sup>(4)</sup> (continued)

over operating free-air temperature range (unless otherwise noted)

(Power-On Hours). The MAX DC voltage is defined as the highest allowed DC regulated voltage, without transients, seen at the ball.

(4) Logic functions and parameter values are not assured out of the range specified in the recommended operating conditions.

### 5.5 Operating Performance Points

This section describes the operating conditions of the device. This section also contains the description of each Operating Performance Point (OPP) for processor clocks and device core clocks.

[Table 5-2](#) describes the maximum supported frequency per speed grade for AM574x devices.

**Table 5-2. Speed Grade Maximum Frequency**

DEVICE	MAXIMUM FREQUENCY (MHz)							
	MPU	DSP	IVA	EVE	GPU	IPU	L3	DDR3/DDR3L
AM5749	1500	750	532	650	532	212.8	266	667 (DDR3-1333)
AM5748	1500	750	532	N/A <sup>(1)</sup>	532	212.8	266	667 (DDR3-1333)
AM5746	1500	750	N/A <sup>(1)</sup>	N/A <sup>(1)</sup>	N/A <sup>(1)</sup>	212.8	266	667 (DDR3-1333)

(1) N/A stands for Not Applicable.

#### 5.5.1 AVS and ABB Requirements

Adaptive Voltage Scaling (AVS) and Adaptive Body Biasing (ABB) are required on most of the vdd\_\* supplies as defined in [Table 5-3](#).

**Table 5-3. AVS and ABB Requirements per vdd\_\* Supply**

SUPPLY	AVS REQUIRED?	ABB REQUIRED?
vdd_core	Yes, for all OPPs	No
vdd_mpu	Yes, for all OPPs	Yes, for all OPPs
vdd_iva	Yes, for all OPPs	Yes, for all OPPs
vdd_dspeve	Yes, for all OPPs	Yes, for all OPPs
vdd_gpu	Yes, for all OPPs	Yes, for all OPPs
vdd_rtc	No	No

### 5.5.2 Voltage And Core Clock Specifications

Table 5-4 shows the recommended OPP per voltage domain.

**Table 5-4. Voltage Domains Operating Performance Points**

DOMAIN	CONDITION	OPP_LOW			OPP_NOM			OPP_OD			OPP_HIGH			
		MIN <sup>(2)</sup>	NOM <sup>(1)</sup>	MAX <sup>(2)</sup>	MIN <sup>(2)</sup>	NOM <sup>(1)</sup>	MAX <sup>(2)</sup>	MIN <sup>(2)</sup>	NOM <sup>(1)</sup>	MAX <sup>(2)</sup>	MIN <sup>(2)</sup>	NOM <sup>(1)</sup>	MAX DC <sup>(3)</sup>	MAX <sup>(2)</sup>
VD_CORE (V)	BOOT (Before AVS is enabled) <sup>(4)</sup>	Not Applicable			1.11	1.15 <sup>(6)</sup>	1.2	Not Applicable			Not Applicable			
	After AVS is enabled <sup>(4)</sup>	Not Applicable			AVS Voltage <sup>(5)</sup> – 3.5%	AVS Voltage <sup>(5)</sup>	1.2	Not Applicable			Not Applicable			
VD_MPU (V)	BOOT (Before AVS is enabled) <sup>(4)</sup>	Not Applicable			1.06	1.15 <sup>(7)</sup>	1.2	Not Applicable			Not Applicable			
	After AVS is enabled <sup>(4)</sup>	AVS Voltage <sup>(5)</sup> – 3.5%	AVS Voltage <sup>(5)</sup>	AVS Voltage <sup>(5)</sup> + 5%	AVS Voltage <sup>(5)</sup> – 3.5%	AVS Voltage <sup>(5)</sup>	1.2	AVS Voltage <sup>(5)</sup> – 3.5%	AVS Voltage <sup>(5)</sup>	AVS Voltage <sup>(5)</sup> + 5%	AVS Voltage <sup>(5)</sup> – 3.5%	AVS Voltage <sup>(5)</sup>	AVS Voltage <sup>(5)</sup> + 2%	AVS Voltage <sup>(5)</sup> + 5%
VD_RTC (V) <sup>(8)</sup>	-	Not Applicable			0.84	0.88 to 1.06	1.16	Not Applicable			Not Applicable			
VD_DSPEVE	BOOT (Before AVS is enabled) <sup>(4)</sup>	Not Applicable			1.02	1.06	1.16	Not Applicable			Not Applicable			
	After AVS is enabled <sup>(4)</sup>	Not Applicable			AVS Voltage <sup>(5)</sup> – 3.5%	AVS Voltage <sup>(5)</sup>	1.16	AVS Voltage <sup>(5)</sup> – 3.5%	AVS Voltage <sup>(5)</sup>	AVS Voltage <sup>(5)</sup> + 5%	AVS Voltage <sup>(5)</sup> – 3.5%	AVS Voltage <sup>(5)</sup>	AVS Voltage <sup>(5)</sup> + 2%	AVS Voltage <sup>(5)</sup> + 5%
Others (V)	BOOT (Before AVS is enabled) <sup>(4)</sup>	Not Applicable			1.02	1.06	1.16	Not Applicable			Not Applicable			
	After AVS is enabled <sup>(4)</sup>	Not Applicable			AVS Voltage <sup>(5)</sup> – 3.5%	AVS Voltage <sup>(5)</sup>	1.16	AVS Voltage <sup>(5)</sup> – 3.5%	AVS Voltage <sup>(5)</sup>	AVS Voltage <sup>(5)</sup> + 5%	AVS Voltage <sup>(5)</sup> – 3.5%	AVS Voltage <sup>(5)</sup>	AVS Voltage <sup>(5)</sup> + 2%	AVS Voltage <sup>(5)</sup> + 5%

- (1) In a typical implementation, the power supply should target the NOM voltage.
- (2) The voltage at the device ball should never be below the MIN voltage or above the MAX voltage for any amount of time. This requirement includes dynamic voltage events such as AC ripple, voltage transients, voltage dips, etc.
- (3) The DC voltage at the device ball should never be above the MAX DC voltage to avoid impact on device reliability and lifetime POH (Power-On Hours). The MAX DC voltage is defined as the highest allowed DC regulated voltage, without transients, seen at the ball.
- (4) For all OPPs, AVS must be enabled to avoid impact on device reliability, lifetime POH (Power-On Hours), and device power.
- (5) The AVS voltages are device-dependent, voltage domain-dependent, and OPP-dependent. They must be read from the STD\_FUSE\_OPP. For information about STD\_FUSE\_OPP Registers address, please refer to the *Control Module* chapter in the device TRM. The power supply should be adjustable over the following ranges for each required OPP:
  - OPP\_LOW for MPU: 0.85 V - 1.15 V
  - OPP\_NOM for MPU: 0.85 V - 1.15 V
  - OPP\_NOM for CORE and Others: 0.85 V - 1.15 V
  - OPP\_OD: 0.885 V - 1.15 V
  - OPP\_HIGH: 0.95 V - 1.25 V
 The AVS voltages will be within the above specified ranges.
- (6) PMIC boot voltage can be set to either 1.06 V or 1.15 V
- (7) PMIC boot voltage can be set to either 1.10 V or 1.15 V
- (8) VD\_RTC can optionally be tied to VD\_CORE and operate at the VD\_CORE AVS voltages.
- (9) The power supply must be programmed with the AVS voltages for the MPU and the CORE voltage domain, either just after the ROM boot or at the earliest possible time in the secondary boot loader before there is significant activity seen on these domains.

Table 5-5 describes the standard processor clocks speed characteristics vs OPP of the device.

**Table 5-5. Supported OPP vs Max Frequency <sup>(1)(2)</sup>**

CLOCK	OPP_LOW	OPP_NOM	OPP_OD	OPP_HIGH
	MAX FREQUENCY (MHz)	MAX FREQUENCY (MHz)	MAX FREQUENCY (MHz)	MAX FREQUENCY (MHz)
<b>VD_MPU</b>				
MPU_CLK	750	1000	1176	1500
<b>VD_DSPEVE</b>				
DSP_CLK	N/A	600	700	750
EVE_FCLK	N/A	535	650	650
<b>VD_IVA</b>				
IVA_GCLK	N/A	388.3	430	532
<b>VD_GPU</b>				
GPU_CLK	N/A	425.6	500	532
<b>VD_CORE</b>				
CORE_IPUX_CLK	N/A	212.8	N/A	N/A
L3_CLK	N/A	266	N/A	N/A
DDR3 / DDR3L	N/A	667 (DDR3-1333)	N/A	N/A
<b>VD_RTC</b>				
RTC_FCLK	N/A	0.034	N/A	N/A

(1) N/A stands for Not Applicable.

(2) Maximum supported frequency is limited to the device speed grade (see Table 5-2, Speed Grade Maximum Frequency).

### 5.5.3 Maximum Supported Frequency

Device modules either receive their clock directly from an external clock input, directly from a PLL, or from a PRCM. Table 5-6 lists the clock source options for each module on this device, along with the maximum frequency that module can accept. To ensure proper module functionality, the device PLLs and dividers must be programmed not to exceed the maximum frequencies listed in this table.

**Table 5-6. Maximum Supported Frequency**

MODULE				CLOCK SOURCES		
INSTANCE NAME	INPUT CLOCK NAME	CLOCK TYPE	MAX. CLOCK ALLOWED (MHz)	PRCM CLOCK NAME	PLL / OSC / SOURCE NAME	PLL / OSC / SOURCE NAME
AES1	AES1_L3_CLK	Int	266	L4SEC_L3_GICLK	CORE_X2_CLK	DPLL_CORE
AES2	AES2_L3_CLK	Int	266	L4SEC_L3_GICLK	CORE_X2_CLK	DPLL_CORE
BB2D	BB2D_FCLK	Func	354.6	BB2D_GFCLK	BB2D_GFCLK	DPLL_CORE
	BB2D_ICLK	Int	266	DSS_L3_GICLK	CORE_X2_CLK	DPLL_CORE
COUNTER_32K	COUNTER_32K_FCLK	Func	0.032	FUNC_32K_CLK	SYS_CLK1/610	OSC0
	COUNTER_32K_ICLK	Int	38.4	WKUPAON_GICLK	SYS_CLK1	OSC0
CTRL_MODULE_BANDGAP	L3INSTR_TS_GCLK	Int	4.8	L3INSTR_TS_GCLK	DPLL_ABE_X2_CLK	DPLL_ABE
					SYS_CLK1	OSC0
CTRL_MODULE_CORE	L4CFG_L4_GICLK	Int	133	L4CFG_L4_GICLK	CORE_X2_CLK	DPLL_CORE
CTRL_MODULE_WKUP	WKUPAON_GICLK	Int	38.4	WKUPAON_GICLK	SYS_CLK1	OSC0
					DPLL_ABE_X2_CLK	DPLL_ABE
DCAN1	DCAN1_FCLK	Func	38.4	DCAN1_SYS_CLK	SYS_CLK1	OSC0
					SYS_CLK2	OSC1
DCAN2	DCAN2_ICLK	Int	266	L4PER2_L3_GICLK	SYS_CLK1	OSC0
					DPLL_ABE_X2_CLK	DPLL_ABE
DES3DES	DES_CLK_L3	Int	266	L4SEC_L3_GICLK	CORE_X2_CLK	DPLL_CORE
DLL	EMIF_DLL_FCLK	Func	<a href="#">EMIF_DLL_FCLK</a>	EMIF_DLL_GCLK	EMIF_DLL_GCLK	DPLL_DDR
DLL_AGING	FCLK	Int	38.4	L3INSTR_DLL_AGING_GCLK	SYS_CLK1	OSC0
					DPLL_ABE_X2_CLK	DPLL_ABE
DMM	DMM_CLK	Int	266	EMIF_L3_GICLK	CORE_X2_CLK	DPLL_CORE
DPLL_DEBUG	SYSCLK	Int	38.4	EMU_SYS_CLK	SYS_CLK1	OSC0
DSP1	DSP1_FICLK	Int & Func	<a href="#">DSP_CLK</a>	DSP1_GFCLK	DSP_GFCLK	DPLL_DSP
DSP2	DSP2_FICLK	Int & Func	<a href="#">DSP_CLK</a>	DSP2_GFCLK	DSP_GFCLK	DPLL_DSP

**Table 5-6. Maximum Supported Frequency (continued)**

MODULE				CLOCK SOURCES		
INSTANCE NAME	INPUT CLOCK NAME	CLOCK TYPE	MAX. CLOCK ALLOWED (MHz)	PRCM CLOCK NAME	PLL / OSC / SOURCE NAME	PLL / OSC / SOURCE NAME
DSS	DSS_HDMI_CEC_CLK	Func	0.032	HDMI_CEC_GFCLK	SYS_CLK1/610	OSC0
	DSS_HDMI_PHY_CLK	Func	48	HDMI_PHY_GFCLK	FUNC_192M_CLK	DPLL_PER
	DSS_CLK	Func	192	DSS_GFCLK	DSS_CLK	DPLL_PER
	HDMI_CLKINP	Func	38.4	HDMI_DPLL_CLK	SYS_CLK1	OSC0
					SYS_CLK2	OSC1
	DSS_L3_ICLK	Int	266	DSS_L3_GICLK	CORE_X2_CLK	DPLL_CORE
	VIDEO1_CLKINP	Func	38.4	VIDEO1_DPLL_CLK	SYS_CLK1	OSC0
					SYS_CLK2	OSC1
	VIDEO2_CLKINP	Func	38.4	VIDEO2_DPLL_CLK	SYS_CLK1	OSC0
					SYS_CLK2	OSC1
	DPLL_DSI1_A_CLK1	Func	209.3	N/A	HDMI_CLK	DPLL_HDMI
					VIDEO1_CLKOUT1	DPLL_VIDEO1
	DPLL_DSI1_B_CLK1	Func	209.3	N/A	VIDEO1_CLKOUT3	DPLL_VIDEO1
					VIDEO2_CLKOUT3	DPLL_VIDEO2
HDMI_CLK					DPLL_HDMI	
DPLL_ABE_X2_CLK	Func	209.3	N/A	DPLL_ABE_X2_CLK	DPLL_ABE	
				HDMI_CLK	DPLL_HDMI	
DPLL_DSI1_C_CLK1	Func	209.3	N/A	VIDEO1_CLKOUT3	DPLL_VIDEO1	
				VIDEO2_CLKOUT1	DPLL_VIDEO2	
DPLL_HDMI_CLK1	Func	185.6	N/A	HDMI_CLK	DPLL_HDMI	
DSS DISPC	LCD1_CLK	Func	209.3	N/A	DPLL_DSI1_A_CLK1	See DSS data in the rows above
					DSS_CLK	
	LCD2_CLK	Func	209.3	N/A	DPLL_DSI1_B_CLK1	
					DSS_CLK	
	LCD3_CLK	Func	209.3	N/A	DPLL_DSI1_C_CLK1	
					DSS_CLK	
	F_CLK	Func	209.3	N/A	DPLL_DSI1_A_CLK1	
					DPLL_DSI1_B_CLK1	
DPLL_DSI1_C_CLK1						
DSS_CLK						
DPLL_HDMI_CLK1	Func	185.6	N/A	HDMI_CLK	DPLL_HDMI	
EFUSE_CTRL_CUST	ocp_clk	Int	133	CUSTEFUSE_L4_GICLK	CORE_X2_CLK	DPLL_CORE
	sys_clk	Func	38.4	CUSTEFUSE_SYS_GFCLK	SYS_CLK1	OSC0
ELM	ELM_ICLK	Int	266	L4PER_L3_GICLK	CORE_X2_CLK	DPLL_CORE
EMIF_OCP_FW	L3_CLK	Int	266	EMIF_L3_GICLK	CORE_X2_CLK	DPLL_CORE
EMIF_PHY1	EMIF_PHY1_FCLK	Func	DDR	EMIF_PHY_GCLK	EMIF_PHY_GCLK	DPLL_DDR
EMIF_PHY2	EMIF_PHY2_FCLK	Func	DDR	EMIF_PHY_GCLK	EMIF_PHY_GCLK	DPLL_DDR
EMIF1	EMIF1_ICLK	Int	266	EMIF_L3_GICLK	CORE_X2_CLK	DPLL_CORE
EMIF2	EMIF2_ICLK	Int	266	EMIF_L3_GICLK	CORE_X2_CLK	DPLL_CORE
EVE1	EVE1_FCLK	Func	EVE_FCLK	EVE1_GFCLK	-	DPLL_DSP
					EVE_GFCLK	DPLL_EVE



**Table 5-6. Maximum Supported Frequency (continued)**

MODULE				CLOCK SOURCES						
INSTANCE NAME	INPUT CLOCK NAME	CLOCK TYPE	MAX. CLOCK ALLOWED (MHz)	PRCM CLOCK NAME	PLL / OSC / SOURCE NAME	PLL / OSC / SOURCE NAME				
EVE2	EVE2_FCLK	Func	EVE_FCLK	EVE2_GFCLK	-	DPLL_DSP				
					EVE_GFCLK	DPLL_EVE				
GMAC_SW	CPTS_RFT_CLK	Func	266	GMAC_RFT_CLK	PER_ABE_X1_GFCLK	DPLL_ABE				
					VIDEO1_CLK	DPLL_VIDEO1				
					VIDEO2_CLK	DPLL_VIDEO2				
					HDMI_CLK	DPLL_HDMI				
					CORE_X2_CLK	DPLL_CORE				
	MAIN_CLK	Int	125	GMAC_MAIN_CLK	GMAC_250M_CLK	DPLL_GMAC				
	MHZ_250_CLK	Func	250	GMII_250MHZ_CLK	GMII_250MHZ_CLK	DPLL_GMAC				
	MHZ_5_CLK	Func	5	RGMII_5MHZ_CLK	GMAC_RMII_HS_CLK	DPLL_GMAC				
	MHZ_50_CLK	Func	50	RMII_50MHZ_CLK	GMAC_RMII_HS_CLK	DPLL_GMAC				
GPIO1	GPIO1_ICLK	Int	38.4	WKUPAON_GICLK	SYS_CLK1	OSC0				
					DPLL_ABE_X2_CLK	DPLL_ABE				
GPIO2	GPIO2_ICLK	Int	266	L4PER_L3_GICLK	FUNC_32K_CLK	OSC0				
					GPIO2_DBCLK	Func	0.032	GPIO_GFCLK	CORE_X2_CLK	DPLL_CORE
GPIO3	GPIO3_ICLK	Int	266	L4PER_L3_GICLK	GPIO_GFCLK	OSC0				
					GPIO3_DBCLK	Func	0.032	GPIO_GFCLK	CORE_X2_CLK	DPLL_CORE
GPIO4	GPIO4_ICLK	Int	266	L4PER_L3_GICLK	GPIO_GFCLK	OSC0				
					GPIO4_DBCLK	Func	0.032	GPIO_GFCLK	CORE_X2_CLK	DPLL_CORE
					PIDBCLK	Func	0.032	GPIO_GFCLK	FUNC_32K_CLK	OSC0
GPIO5	GPIO5_ICLK	Int	266	L4PER_L3_GICLK	GPIO_GFCLK	OSC0				
					GPIO5_DBCLK	Func	0.032	GPIO_GFCLK	CORE_X2_CLK	DPLL_CORE
					PIDBCLK	Func	0.032	GPIO_GFCLK	FUNC_32K_CLK	OSC0
GPIO6	GPIO6_ICLK	Int	266	L4PER_L3_GICLK	GPIO_GFCLK	OSC0				
					GPIO6_DBCLK	Func	0.032	GPIO_GFCLK	CORE_X2_CLK	DPLL_CORE
					PIDBCLK	Func	0.032	GPIO_GFCLK	FUNC_32K_CLK	OSC0
GPIO7	GPIO7_ICLK	Int	266	L4PER_L3_GICLK	GPIO_GFCLK	OSC0				
					GPIO7_DBCLK	Func	0.032	GPIO_GFCLK	CORE_X2_CLK	DPLL_CORE
					PIDBCLK	Func	0.032	GPIO_GFCLK	FUNC_32K_CLK	OSC0
GPIO8	GPIO8_ICLK	Int	266	L4PER_L3_GICLK	GPIO_GFCLK	OSC0				
					GPIO8_DBCLK	Func	0.032	GPIO_GFCLK	CORE_X2_CLK	DPLL_CORE
					PIDBCLK	Func	0.032	GPIO_GFCLK	FUNC_32K_CLK	OSC0
GPMC	GPMC_FCLK	Int	266	L3MAIN1_L3_GICLK	GPIO_GFCLK	OSC0				
GPU	GPU_FCLK1	Func	GPU_CLK	GPU_CORE_GCLK	CORE_GPU_CLK	DPLL_CORE				
					PER_GPU_CLK	DPLL_PER				
					GPU_GCLK	DPLL_GPU				
	GPU_FCLK2	Func	GPU_CLK	GPU_HYD_GCLK	CORE_GPU_CLK	DPLL_CORE				
					PER_GPU_CLK	DPLL_PER				
					GPU_GCLK	DPLL_GPU				
GPU_ICLK	Int	266	GPU_L3_GICLK	GPU_L3_GICLK	CORE_X2_CLK	DPLL_CORE				

**Table 5-6. Maximum Supported Frequency (continued)**

MODULE				CLOCK SOURCES		
INSTANCE NAME	INPUT CLOCK NAME	CLOCK TYPE	MAX. CLOCK ALLOWED (MHz)	PRCM CLOCK NAME	PLL / OSC / SOURCE NAME	PLL / OSC / SOURCE NAME
HDMI PHY	DSS_HDMI_PHY_CLK	Func	38.4	HDMI_PHY_GFCLK	FUNC_192M_CLK	DPLL_PER
HDQ1W	HDQ1W_ICLK	Int & Func	266	L4PER_L3_GICLK	CORE_X2_CLK	DPLL_CORE
	HDQ1W_FCLK	Func	12	PER_12M_GFCLK	FUNC_192M_CLK	DPLL_PER
I2C1	I2C1_ICLK	Int	266	L4PER_L3_GICLK	CORE_X2_CLK	DPLL_CORE
	I2C1_FCLK	Func	96	PER_96M_GFCLK	FUNC_192M_CLK	DPLL_PER
I2C2	I2C2_ICLK	Int	266	L4PER_L3_GICLK	CORE_X2_CLK	DPLL_CORE
	I2C2_FCLK	Func	96	PER_96M_GFCLK	FUNC_192M_CLK	DPLL_PER
I2C3	I2C3_ICLK	Int	266	L4PER_L3_GICLK	CORE_X2_CLK	DPLL_CORE
	I2C3_FCLK	Func	96	PER_96M_GFCLK	FUNC_192M_CLK	DPLL_PER
I2C4	I2C4_ICLK	Int	266	L4PER_L3_GICLK	CORE_X2_CLK	DPLL_CORE
	I2C4_FCLK	Func	96	PER_96M_GFCLK	FUNC_192M_CLK	DPLL_PER
I2C5	I2C5_ICLK	Int	266	IPU_L3_GICLK	CORE_X2_CLK	DPLL_CORE
	I2C5_FCLK	Func	96	IPU_96M_GFCLK	FUNC_192M_CLK	DPLL_PER
IEEE1500_2_OCP	PI_L3CLK	Int & Func	266	L3INIT_L3_GICLK	CORE_X2_CLK	DPLL_CORE
IPU1	IPU1_GFCLK	Int & Func	425.6	IPU1_GFCLK	DPLL_ABE_X2_CLK	DPLL_ABE
					CORE_IPU_ISS_BOOST_CLK	DPLL_CORE
IPU2	IPU2_GFCLK	Int & Func	425.6	IPU2_GFCLK	CORE_IPU_ISS_BOOST_CLK	DPLL_CORE
IVA	IVA_GCLK	Int	<a href="#">IVA_GCLK</a>	IVA_GCLK	IVA_GFCLK	DPLL_IVA
KBD	KBD_FCLK	Func	0.032	WKUPAON_SYS_GCLK	FUNC_32K_CLK	OSC0
	PICLKKB	Func	0.032	WKUPAON_SYS_GCLK		
	KBD_ICLK	Int	38.4	WKUPAON_GICLK	SYS_CLK1	OSC0
	PICLKOC	Int	38.4	WKUPAON_GICLK	DPLL_ABE_X2_CLK	DPLL_ABE
L3_INSTR	L3_CLK	Int	<a href="#">L3_CLK</a>	L3INSTR_L3_GICLK	CORE_X2_CLK	DPLL_CORE
L3_MAIN	L3_CLK1	Int	<a href="#">L3_CLK</a>	L3MAIN1_L3_GICLK	CORE_X2_CLK	DPLL_CORE
	L3_CLK2	Int	<a href="#">L3_CLK</a>	L3INSTR_L3_GICLK	CORE_X2_CLK	DPLL_CORE
L4_CFG	L4_CFG_CLK	Int	133	L4CFG_L3_GICLK	CORE_X2_CLK	DPLL_CORE
L4_PER1	L4_PER1_CLK	Int	133	L4PER_L3_GICLK	CORE_X2_CLK	DPLL_CORE
L4_PER2	L4_PER2_CLK	Int	133	L4PER2_L3_GICLK	CORE_X2_CLK	DPLL_CORE
L4_PER3	L4_PER3_CLK	Int	133	L4PER3_L3_GICLK	CORE_X2_CLK	DPLL_CORE
L4_WKUP	L4_WKUP_CLK	Int	38.4	WKUPAON_GICLK	SYS_CLK1	OSC0
					DPLL_ABE_X2_CLK	DPLL_ABE
MAILBOX1	MAILBOX1_FLCK	Int	266	L4CFG_L3_GICLK	CORE_X2_CLK	DPLL_CORE
MAILBOX2	MAILBOX2_FLCK	Int	266	L4CFG_L3_GICLK	CORE_X2_CLK	DPLL_CORE
MAILBOX3	MAILBOX3_FLCK	Int	266	L4CFG_L3_GICLK	CORE_X2_CLK	DPLL_CORE
MAILBOX4	MAILBOX4_FLCK	Int	266	L4CFG_L3_GICLK	CORE_X2_CLK	DPLL_CORE
MAILBOX5	MAILBOX5_FLCK	Int	266	L4CFG_L3_GICLK	CORE_X2_CLK	DPLL_CORE
MAILBOX6	MAILBOX6_FLCK	Int	266	L4CFG_L3_GICLK	CORE_X2_CLK	DPLL_CORE
MAILBOX7	MAILBOX7_FLCK	Int	266	L4CFG_L3_GICLK	CORE_X2_CLK	DPLL_CORE
MAILBOX8	MAILBOX8_FLCK	Int	266	L4CFG_L3_GICLK	CORE_X2_CLK	DPLL_CORE
MAILBOX9	MAILBOX9_FLCK	Int	266	L4CFG_L3_GICLK	CORE_X2_CLK	DPLL_CORE

**Table 5-6. Maximum Supported Frequency (continued)**

MODULE				CLOCK SOURCES		
INSTANCE NAME	INPUT CLOCK NAME	CLOCK TYPE	MAX. CLOCK ALLOWED (MHz)	PRCM CLOCK NAME	PLL / OSC / SOURCE NAME	PLL / OSC / SOURCE NAME
MAILBOX10	MAILBOX10_FLCK	Int	266	L4CFG_L3_GICLK	CORE_X2_CLK	DPLL_CORE
MAILBOX11	MAILBOX11_FLCK	Int	266	L4CFG_L3_GICLK	CORE_X2_CLK	DPLL_CORE
MAILBOX12	MAILBOX12_FLCK	Int	266	L4CFG_L3_GICLK	CORE_X2_CLK	DPLL_CORE
MAILBOX13	MAILBOX13_FLCK	Int	266	L4CFG_L3_GICLK	CORE_X2_CLK	DPLL_CORE
McASP1	MCASP1_AHCLKR	Func	100	MCASP1_AHCLKR	ABE_24M_GFCLK	DPLL_ABE
					ABE_SYS_CLK	OSC0
					FUNC_24M_GFCLK	DPLL_PER
					SYS_CLK2	OSC1
					XREF_CLK0	XREF_CLK0
					XREF_CLK1	XREF_CLK1
					XREF_CLK2	XREF_CLK2
					XREF_CLK3	XREF_CLK3
					MLB_CLK	Module MLB
					MLBP_CLK	Module MLB
	MCASP1_AHCLKX	Func	100	MCASP1_AHCLKX	ABE_24M_GFCLK	DPLL_ABE
					ABE_SYS_CLK	OSC0
					FUNC_24M_GFCLK	DPLL_PER
					SYS_CLK2	OSC1
					XREF_CLK0	XREF_CLK0
					XREF_CLK1	XREF_CLK1
					XREF_CLK2	XREF_CLK2
					XREF_CLK3	XREF_CLK3
	MCASP1_FCLK	Func	192	MCASP1_AUX_GFCLK	PER_ABE_X1_GFCLK	DPLL_ABE
					VIDEO1_CLK	DPLL_VIDEO1
VIDEO2_CLK					DPLL_VIDEO2	
HDMI_CLK					DPLL_HDMI	
MCASP1_ICLK	Int	266	IPU_L3_GICLK	CORE_X2_CLK	DPLL_CORE	

**Table 5-6. Maximum Supported Frequency (continued)**

MODULE				CLOCK SOURCES			
INSTANCE NAME	INPUT CLOCK NAME	CLOCK TYPE	MAX. CLOCK ALLOWED (MHz)	PRCM CLOCK NAME	PLL / OSC / SOURCE NAME	PLL / OSC / SOURCE NAME	
McASP2	MCASP2_AHCLKR	Func	100	MCASP2_AHCLKR	ABE_24M_GFCLK	DPLL_ABE	
					ABE_SYS_CLK	OSC0	
					FUNC_24M_GFCLK	DPLL_PER	
					SYS_CLK2	OSC1	
					XREF_CLK0	XREF_CLK0	
					XREF_CLK1	XREF_CLK1	
					XREF_CLK2	XREF_CLK2	
					XREF_CLK3	XREF_CLK3	
					MLB_CLK	Module MLB	
	MLBP_CLK	Module MLB					
	MCASP2_AHCLKX	Func	100	MCASP2_AHCLKX	ABE_24M_GFCLK	DPLL_ABE	
					ABE_SYS_CLK	OSC0	
					FUNC_24M_GFCLK	DPLL_PER	
					SYS_CLK2	OSC1	
					XREF_CLK0	XREF_CLK0	
					XREF_CLK1	XREF_CLK1	
					XREF_CLK2	XREF_CLK2	
					XREF_CLK3	XREF_CLK3	
					MLB_CLK	Module MLB	
	MLBP_CLK	Module MLB					
	MCASP2_FCLK	Func	192	MCASP2_AUX_GFCLK	PER_ABE_X1_GFCLK	DPLL_ABE	
					VIDEO1_CLK	DPLL_VIDEO1	
					VIDEO2_CLK	DPLL_VIDEO2	
					HDMI_CLK	DPLL_HDMI	
	MCASP2_ICLK	Int	266	L4PER2_L3_GICLK	CORE_X2_CLK	DPLL_CORE	
	McASP3	MCASP3_AHCLKX	Func	100	MCASP3_AHCLKX	ABE_24M_GFCLK	DPLL_ABE
						ABE_SYS_CLK	OSC0
FUNC_24M_GFCLK						DPLL_PER	
SYS_CLK2						OSC1	
XREF_CLK0						XREF_CLK0	
XREF_CLK1						XREF_CLK1	
XREF_CLK2						XREF_CLK2	
XREF_CLK3						XREF_CLK3	
MLB_CLK						Module MLB	
MLBP_CLK		Module MLB					
MCASP3_FCLK		Func	192	MCASP3_AUX_GFCLK	PER_ABE_X1_GFCLK	DPLL_ABE	
					VIDEO1_CLK	DPLL_ABE	
					VIDEO2_CLK	DPLL_VIDEO2	
					HDMI_CLK	DPLL_HDMI	
MCASP3_ICLK		Int	266	L4PER2_L3_GICLK	CORE_X2_CLK	DPLL_CORE	

**Table 5-6. Maximum Supported Frequency (continued)**

MODULE				CLOCK SOURCES		
INSTANCE NAME	INPUT CLOCK NAME	CLOCK TYPE	MAX. CLOCK ALLOWED (MHz)	PRCM CLOCK NAME	PLL / OSC / SOURCE NAME	PLL / OSC / SOURCE NAME
McASP4	MCASP4_AHCLKX	Func	100	MCASP4_AHCLKX	ABE_24M_GFCLK	DPLL_ABE
					ABE_SYS_CLK	OSC0
					FUNC_24M_GFCLK	DPLL_PER
					SYS_CLK2	OSC1
					XREF_CLK0	XREF_CLK0
					XREF_CLK1	XREF_CLK1
					XREF_CLK2	XREF_CLK2
					XREF_CLK3	XREF_CLK3
					MLB_CLK	Module MLB
	MLBP_CLK	Module MLB				
	MCASP4_FCLK	Func	192	MCASP4_AUX_GFCLK	PER_ABE_X1_GFCLK	DPLL_ABE
					VIDEO1_CLK	DPLL_ABE
					VIDEO2_CLK	DPLL_VIDEO2
HDMI_CLK					DPLL_HDMI	
MCASP4_ICLK	Int	266	L4PER2_L3_GICLK	CORE_X2_CLK	DPLL_CORE	
McASP5	MCASP5_AHCLKX	Func	100	MCASP5_AHCLKX	ABE_24M_GFCLK	DPLL_ABE
					ABE_SYS_CLK	OSC0
					FUNC_24M_GFCLK	DPLL_PER
					SYS_CLK2	OSC1
					XREF_CLK0	XREF_CLK0
					XREF_CLK1	XREF_CLK1
					XREF_CLK2	XREF_CLK2
					XREF_CLK3	XREF_CLK3
					MLB_CLK	Module MLB
	MLBP_CLK	Module MLB				
	MCASP5_FCLK	Func	192	MCASP5_AUX_GFCLK	PER_ABE_X1_GFCLK	DPLL_ABE
					VIDEO1_CLK	DPLL_ABE
					VIDEO2_CLK	DPLL_VIDEO2
HDMI_CLK					DPLL_HDMI	
MCASP5_ICLK	Int	266	L4PER2_L3_GICLK	CORE_X2_CLK	DPLL_CORE	
McASP6	MCASP6_AHCLKX	Func	100	MCASP6_AHCLKX	ABE_24M_GFCLK	DPLL_ABE
					FUNC_24M_GFCLK	DPLL_PER
					MLB_CLK	Module MLB
					MLBP_CLK	Module MLB
					ABE_SYS_CLK	OSC0
					SYS_CLK2	OSC1
					XREF_CLK0	XREF_CLK0
					XREF_CLK1	XREF_CLK1
					XREF_CLK2	XREF_CLK2
	XREF_CLK3	XREF_CLK3				
	MCASP6_FCLK	Func	192	MCASP6_AUX_GFCLK	PER_ABE_X1_GFCLK	DPLL_ABE
					VIDEO1_CLK	DPLL_ABE
					VIDEO2_CLK	DPLL_VIDEO2
HDMI_CLK					DPLL_HDMI	
MCASP6_ICLK	Int	266	L4PER2_L3_GICLK	CORE_X2_CLK	DPLL_CORE	

**Table 5-6. Maximum Supported Frequency (continued)**

MODULE				CLOCK SOURCES		
INSTANCE NAME	INPUT CLOCK NAME	CLOCK TYPE	MAX. CLOCK ALLOWED (MHz)	PRCM CLOCK NAME	PLL / OSC / SOURCE NAME	PLL / OSC / SOURCE NAME
McASP7	MCASP7_AHCLKX	Func	100	MCASP7_AHCLKX	ABE_24M_GFCLK	DPLL_ABE
					ABE_SYS_CLK	OSC0
					FUNC_24M_GFCLK	DPLL_PER
					SYS_CLK2	OSC1
					XREF_CLK0	XREF_CLK0
					XREF_CLK1	XREF_CLK1
					XREF_CLK2	XREF_CLK2
					XREF_CLK3	XREF_CLK3
					MLB_CLK	Module MLB
	MLBP_CLK	Module MLB				
	MCASP7_FCLK	Func	192	MCASP7_AUX_GFCLK	PER_ABE_X1_GFCLK	DPLL_ABE
					VIDEO1_CLK	DPLL_ABE
VIDEO2_CLK					DPLL_VIDEO2	
HDMI_CLK					DPLL_HDMI	
MCASP7_ICLK	Int	266	L4PER2_L3_GICLK	CORE_X2_CLK	DPLL_CORE	
McASP8	MCASP8_AHCLKX	Func	100	MCASP8_AHCLKX	ABE_24M_GFCLK	DPLL_ABE
					ABE_SYS_CLK	OSC0
					FUNC_24M_GFCLK	DPLL_PER
					SYS_CLK2	OSC1
					XREF_CLK0	XREF_CLK0
					XREF_CLK1	XREF_CLK1
					XREF_CLK2	XREF_CLK2
					XREF_CLK3	XREF_CLK3
					MLB_CLK	Module MLB
	MLBP_CLK	Module MLB				
	MCASP8_FCLK	Func	192	MCASP8_AUX_GFCLK	PER_ABE_X1_GFCLK	DPLL_ABE
					VIDEO1_CLK	DPLL_ABE
VIDEO2_CLK					DPLL_VIDEO2	
HDMI_CLK					DPLL_HDMI	
MCASP8_ICLK	Int	266	L4PER2_L3_GICLK	CORE_X2_CLK	DPLL_CORE	
McSPI1	SPI1_ICLK	Int	266	L4PER_L3_GICLK	CORE_X2_CLK	DPLL_CORE
	SPI1_FCLK	Func	48	PER_48M_GFCLK	PER_48M_GFCLK	DPLL_PER
McSPI2	SPI2_ICLK	Int	266	L4PER_L3_GICLK	CORE_X2_CLK	DPLL_CORE
	SPI2_FCLK	Func	48	PER_48M_GFCLK	PER_48M_GFCLK	DPLL_PER
McSPI3	SPI3_ICLK	Int	266	L4PER_L3_GICLK	CORE_X2_CLK	DPLL_CORE
	SPI3_FCLK	Func	48	PER_48M_GFCLK	PER_48M_GFCLK	DPLL_PER
McSPI4	SPI4_ICLK	Int	266	L4PER_L3_GICLK	CORE_X2_CLK	DPLL_CORE
	SPI4_FCLK	Func	48	PER_48M_GFCLK	PER_48M_GFCLK	DPLL_PER
MLB_SS	MLB_L3_ICLK	Int	266	MLB_SHB_L3_GICLK	CORE_X2_CLK	DPLL_CORE
	MLB_L4_ICLK	Int	133	MLB_SPB_L4_GICLK	CORE_X2_CLK	DPLL_CORE
	MLB_FCLK	Func	266	MLB_SYS_L3_GFCLK	CORE_X2_CLK	DPLL_CORE

**Table 5-6. Maximum Supported Frequency (continued)**

MODULE				CLOCK SOURCES		
INSTANCE NAME	INPUT CLOCK NAME	CLOCK TYPE	MAX. CLOCK ALLOWED (MHz)	PRCM CLOCK NAME	PLL / OSC / SOURCE NAME	PLL / OSC / SOURCE NAME
MMC1	MMC1_CLK_32K	Func	0.032	L3INIT_32K_GFCLK	FUNC_32K_CLK	OSC0
	MMC1_FCLK	Func	192	MMC1_GFCLK	FUNC_192M_CLK	DPLL_PER
			128		FUNC_256M_CLK	DPLL_PER
	MMC1_ICLK1	Int	266	L3INIT_L3_GICLK	CORE_X2_CLK	DPLL_CORE
MMC1_ICLK2	Int	133	L3INIT_L4_GICLK	CORE_X2_CLK	DPLL_CORE	
MMC2	MMC2_CLK_32K	Func	0.032	L3INIT_32K_GFCLK	FUNC_32K_CLK	OSC0
	MMC2_FCLK	Func	192	MMC2_GFCLK	FUNC_192M_CLK	DPLL_PER
			128		FUNC_256M_CLK	DPLL_PER
	MMC2_ICLK1	Int	266	L3INIT_L3_GICLK	CORE_X2_CLK	DPLL_CORE
MMC2_ICLK2	Int	133	L3INIT_L4_GICLK	CORE_X2_CLK	DPLL_CORE	
MMC3	MMC3_ICLK	Int	266	L4PER_L3_GICLK	CORE_X2_CLK	DPLL_CORE
	MMC3_CLK_32K	Func	0.032	L4PER_32K_GFCLK	FUNC_32K_CLK	OSC0
	MMC3_FCLK	Func	48	MMC3_GFCLK	FUNC_192M_CLK	DPLL_PER
192						
MMC4	MMC4_ICLK	Int	266	L4PER_L3_GICLK	CORE_X2_CLK	DPLL_CORE
	MMC4_CLK_32K	Func	0.032	L4PER_32K_GFCLK	FUNC_32K_CLK	OSC0
	MMC4_FCLK	Func	48	MMC4_GFCLK	FUNC_192M_CLK	DPLL_PER
192						
MMU_EDMA	MMU1_CLK	Int	266	L3MAIN1_L3_GICLK	CORE_X2_CLK	DPLL_CORE
MMU_PCIESS	MMU2_CLK	Int	266	L3MAIN1_L3_GICLK	CORE_X2_CLK	DPLL_CORE
MPU	MPU_CLK	Int & Func	MPU_CLK	MPU_GCLK	MPU_GCLK	DPLL_MPU
MPU_EMU_DBG	FCLK	Int	38.4	EMU_SYS_CLK	SYS_CLK1	OSC0
					MPU_GCLK	DPLL_MPU
OCMC_RAM1	OCMC1_L3_CLK	Int	266	L3MAIN1_L3_GICLK	CORE_X2_CLK	DPLL_CORE
OCMC_RAM2	OCMC2_L3_CLK	Int	266	L3MAIN1_L3_GICLK	CORE_X2_CLK	DPLL_CORE
OCMC_RAM3	OCMC3_L3_CLK	Int	266	L3MAIN1_L3_GICLK	CORE_X2_CLK	DPLL_CORE
OCMC_ROM	OCMC_L3_CLK	Int	266	L3MAIN1_L3_GICLK	CORE_X2_CLK	DPLL_CORE
OCP_WP_NOC	PICLKOCPL3	Int	266	L3INSTR_L3_GICLK	CORE_X2_CLK	DPLL_CORE
OCP2SCP1	L4CFG1_ADAPTE R_CLKIN	Int	133	L3INIT_L4_GICLK	CORE_X2_CLK	DPLL_CORE
OCP2SCP2	L4CFG2_ADAPTE R_CLKIN	Int	133	L4CFG_L4_GICLK	CORE_X2_CLK	DPLL_CORE
OCP2SCP3	L4CFG3_ADAPTE R_CLKIN	Int	133	L3INIT_L4_GICLK	CORE_X2_CLK	DPLL_CORE
PCIe_SS1	PCIE1_PHY_WKU P_CLK	Func	0.032	PCIE_32K_GFCLK	FUNC_32K_CLK	OSC0
	PCIe_SS1_FICLK	Int	266	PCIE_L3_GICLK	CORE_X2_CLK	DPLL_CORE
	PCIEPHY_CLK	Func	2500	PCIE_PHY_GCLK	PCIE_PHY_GCLK	APLL_PCIE
	PCIEPHY_CLK_DI V	Func	1250	PCIE_PHY_DIV_GCLK	PCIE_PHY_DIV_GCLK	APLL_PCIE
	PCIE1_REF_CLKI N	Func	34.3	PCIE_REF_GFCLK	CORE_USB_OTG_SS_ LFPS_TX_CLK	DPLL_CORE
	PCIE1_PWR_CLK	Func	38.4	PCIE_SYS_GFCLK	SYS_CLK1	OSC0

**Table 5-6. Maximum Supported Frequency (continued)**

MODULE				CLOCK SOURCES		
INSTANCE NAME	INPUT CLOCK NAME	CLOCK TYPE	MAX. CLOCK ALLOWED (MHz)	PRCM CLOCK NAME	PLL / OSC / SOURCE NAME	PLL / OSC / SOURCE NAME
PCIe_SS2	PCIe2_PHY_WKU_P_CLK	Func	0.032	PCIe_32K_GFCLK	FUNC_32K_CLK	OSC0
	PCIe_SS2_FICLK	Func	266	PCIe_L3_GICLK	CORE_X2_CLK	DPLL_CORE
	PCIEPHY_CLK	Func	2500	PCIE_PHY_GCLK	PCIE_PHY_GCLK	APLL_PCIE
	PCIEPHY_CLK_DIV	Func	1250	PCIE_PHY_DIV_GCLK	PCIE_PHY_DIV_GCLK	APLL_PCIE
	PCIe2_REF_CLKIN	Func	34.3	PCIe_REF_GFCLK	CORE_USB_OTG_SS_LFPS_TX_CLK	DPLL_CORE
	PCIe2_PWR_CLK	Func	38.4	PCIe_SYS_GFCLK	SYS_CLK1	OSC0
PRCM_MPU	32K_CLK	Func	0.032	FUNC_32K_CLK	SYS_CLK1/610	OSC0
	SYS_CLK	Func	38.4	WKUPAON_ICLK	SYS_CLK1	OSC0
					DPLL_ABE_X2_CLK	DPLL_ABE
PRU-ICSS1	PRUSS1_IEP_CLK	Func	200	ICSS_IEP_CLK	ICSS_IEP_CLK	DPLL_GMAC
	PRUSS1_GICLK	Int	200	ICSS_CLK	ICSS_CLK	DPLL_GMAC
	PRUSS1_UART_GFCLK	Func	192	PER_192M_GFCLK	FUNC_192M_CLK	DPLL_PER
PRU-ICSS2	PRUSS2_IEP_CLK	Func	200	ICSS_IEP_CLK	ICSS_IEP_CLK	DPLL_GMAC
	PRUSS2_GICLK	Int	200	ICSS_CLK	ICSS_CLK	DPLL_GMAC
	PRUSS2_UART_GFCLK	Func	192	PER_192M_GFCLK	FUNC_192M_CLK	DPLL_PER
PWMSS1	PWMSS1_GICLK	Int & Func	266	L4PER2_L3_GICLK	CORE_X2_CLK	DPLL_CORE
PWMSS2	PWMSS2_GICLK	Int & Func	266	L4PER2_L3_GICLK	CORE_X2_CLK	DPLL_CORE
PWMSS3	PWMSS3_GICLK	Int & Func	266	L4PER2_L3_GICLK	CORE_X2_CLK	DPLL_CORE
QSPI	QSPI_ICLK	Int	266	L4PER2_L3_GICLK	CORE_X2_CLK	DPLL_CORE
	QSPI_FCLK	Func	128	QSPI_GFCLK	FUNC_256M_CLK	DPLL_PER
					PER_QSPI_CLK	DPLL_PER
RNG	RNG_ICLK	Int	266	L4SEC_L3_GICLK	CORE_X2_CLK	DPLL_CORE
RTC_SS	RTC_ICLK	Int	133	RTC_L4_GICLK	CORE_X2_CLK	DPLL_CORE
	RTC_FCLK	Func	RTC_FCLK	RTC_AUX_CLK	rtc_osc_xi_clk32	RTC Oscillator
				FUNC_32K_CLK	SYS_CLK1/610	OSC0
SAR_ROM	PRCM_ROM_CLOCK	Int	266	L4CFG_L3_GICLK	CORE_X2_CLK	DPLL_CORE
SATA	SATA_FICLK	Int	266	L3INIT_L3_GICLK	CORE_X2_CLK	DPLL_CORE
	SATA_PMALIVE_FCLK	Func	48	L3INIT_48M_GFCLK	FUNC_192M_CLK	DPLL_PER
	REF_CLK	Func	38	SATA_REF_GFCLK	SYS_CLK1	OSC0
SDMA	SDMA_FCLK	Int & Func	266	DMA_L3_GICLK	CORE_X2_CLK	DPLL_CORE
SHA2MD51	SHAM_1_CLK	Int	266	L4SEC_L3_GICLK	CORE_X2_CLK	DPLL_CORE
SHA2MD52	SHAM_2_CLK	Int	266	L4SEC_L3_GICLK	CORE_X2_CLK	DPLL_CORE
SL2	IVA_GCLK	Int	IVA_GCLK	IVA_GCLK	IVA_GFCLK	DPLL_IVA
SMARTREFLEX_CORE	MCLK	Int	133	COREAON_L4_GICLK	CORE_X2_CLK	DPLL_CORE
	SYSCLK	Func	38.4	WKUPAON_ICLK	SYS_CLK1	OSC0
					DPLL_ABE_X2_CLK	DPLL_ABE



**Table 5-6. Maximum Supported Frequency (continued)**

MODULE				CLOCK SOURCES		
INSTANCE NAME	INPUT CLOCK NAME	CLOCK TYPE	MAX. CLOCK ALLOWED (MHz)	PRCM CLOCK NAME	PLL / OSC / SOURCE NAME	PLL / OSC / SOURCE NAME
SMARTREFLEX_D SPEVE	MCLK	Int	133	COREAON_L4_GICLK	CORE_X2_CLK	DPLL_CORE
	SYSCLK	Func	38.4	WKUPAON_ICLK	SYS_CLK1 DPLL_ABE_X2_CLK	OSC0 DPLL_ABE
SMARTREFLEX_G PU	MCLK	Int	133	COREAON_L4_GICLK	CORE_X2_CLK	DPLL_CORE
	SYSCLK	Func	38.4	WKUPAON_ICLK	SYS_CLK1 DPLL_ABE_X2_CLK	OSC0 DPLL_ABE
SMARTREFLEX_IV AHD	MCLK	Int	133	COREAON_L4_GICLK	CORE_X2_CLK	DPLL_CORE
	SYSCLK	Func	38.4	WKUPAON_ICLK	SYS_CLK1 DPLL_ABE_X2_CLK	OSC0 DPLL_ABE
SMARTREFLEX_M PU	MCLK	Int	133	COREAON_L4_GICLK	CORE_X2_CLK	DPLL_CORE
	SYSCLK	Func	38.4	WKUPAON_ICLK	SYS_CLK1 DPLL_ABE_X2_CLK	OSC0 DPLL_ABE
SPINLOCK	SPINLOCK_ICLK	Int	266	L4CFG_L3_GICLK	CORE_X2_CLK	DPLL_CORE
TIMER1	TIMER1_ICLK	Int	38.4	WKUPAON_GICLK	SYS_CLK1	OSC0
					DPLL_ABE_X2_CLK	DPLL_ABE
	TIMER1_FCLK	Func	100	TIMER1_GFCLK	SYS_CLK1	OSC0
					FUNC_32K_CLK	OSC0
					SYS_CLK2	OSC1
					XREF_CLK0	XREF_CLK0
					XREF_CLK1	XREF_CLK1
					XREF_CLK2	XREF_CLK2
					XREF_CLK3	XREF_CLK3
					DPLL_ABE_X2_CLK	DPLL_ABE
VIDEO1_CLK	DPLL_VIDEO1					
VIDEO2_CLK	DPLL_VIDEO2					
TIMER2	TIMER2_ICLK	Int	266	L4PER_L3_GICLK	CORE_X2_CLK	DPLL_CORE
					DPLL_ABE_X2_CLK	DPLL_ABE
	TIMER2_FCLK	Func	100	TIMER2_GFCLK	SYS_CLK1	OSC0
					FUNC_32K_CLK	OSC0
					SYS_CLK2	OSC1
					XREF_CLK0	XREF_CLK0
					XREF_CLK1	XREF_CLK1
					XREF_CLK2	XREF_CLK2
					XREF_CLK3	XREF_CLK3
					DPLL_ABE_X2_CLK	DPLL_ABE
VIDEO1_CLK	DPLL_VIDEO1					
VIDEO2_CLK	DPLL_VIDEO2					
HDMI_CLK	DPLL_HDMI					

**Table 5-6. Maximum Supported Frequency (continued)**

MODULE				CLOCK SOURCES		
INSTANCE NAME	INPUT CLOCK NAME	CLOCK TYPE	MAX. CLOCK ALLOWED (MHz)	PRCM CLOCK NAME	PLL / OSC / SOURCE NAME	PLL / OSC / SOURCE NAME
TIMER3	TIMER3_ICLK	Int	266	L4PER_L3_GICLK	CORE_X2_CLK	DPLL_CORE
	TIMER3_FCLK	Func	100	TIMER3_GFCLK	SYS_CLK1	OSC0
					FUNC_32K_CLK	OSC0
					SYS_CLK2	OSC1
					XREF_CLK0	XREF_CLK0
					XREF_CLK1	XREF_CLK1
					XREF_CLK2	XREF_CLK2
					XREF_CLK3	XREF_CLK3
					DPLL_ABE_X2_CLK	DPLL_ABE
					VIDEO1_CLK	DPLL_VIDEO1
VIDEO2_CLK	DPLL_VIDEO2					
HDMI_CLK	DPLL_HDMI					
TIMER4	TIMER4_ICLK	Int	266	L4PER_L3_GICLK	CORE_X2_CLK	DPLL_CORE
	TIMER4_FCLK	Func	100	TIMER4_GFCLK	SYS_CLK1	OSC0
					FUNC_32K_CLK	OSC0
					SYS_CLK2	OSC1
					XREF_CLK0	XREF_CLK0
					XREF_CLK1	XREF_CLK1
					XREF_CLK2	XREF_CLK2
					XREF_CLK3	XREF_CLK3
					DPLL_ABE_X2_CLK	DPLL_ABE
					VIDEO1_CLK	DPLL_VIDEO1
VIDEO2_CLK	DPLL_VIDEO2					
HDMI_CLK	DPLL_HDMI					
TIMER5	TIMER5_ICLK	Int	266	IPU_L3_GICLK	CORE_X2_CLK	DPLL_CORE
	TIMER5_FCLK	Func	100	TIMER5_GFCLK	SYS_CLK1	OSC0
					FUNC_32K_CLK	OSC0
					SYS_CLK2	OSC1
					XREF_CLK0	XREF_CLK0
					XREF_CLK1	XREF_CLK1
					XREF_CLK2	XREF_CLK2
					XREF_CLK3	XREF_CLK3
					DPLL_ABE_X2_CLK	DPLL_ABE
					VIDEO1_CLK	DPLL_VIDEO1
VIDEO2_CLK	DPLL_VIDEO2					
HDMI_CLK	DPLL_HDMI					
CLKOUTMUX[0]	CLKOUTMUX[0]					

**Table 5-6. Maximum Supported Frequency (continued)**

MODULE				CLOCK SOURCES		
INSTANCE NAME	INPUT CLOCK NAME	CLOCK TYPE	MAX. CLOCK ALLOWED (MHz)	PRCM CLOCK NAME	PLL / OSC / SOURCE NAME	PLL / OSC / SOURCE NAME
TIMER6	TIMER6_ICLK	Int	266	IPU_L3_GICLK	CORE_X2_CLK	DPLL_CORE
	TIMER6_FCLK	Func	100	TIMER6_GFCLK	SYS_CLK1	OSC0
					FUNC_32K_CLK	OSC0
					SYS_CLK2	OSC1
					XREF_CLK0	XREF_CLK0
					XREF_CLK1	XREF_CLK1
					XREF_CLK2	XREF_CLK2
					XREF_CLK3	XREF_CLK3
					DPLL_ABE_X2_CLK	DPLL_ABE
					VIDEO1_CLK	DPLL_VIDEO1
					VIDEO2_CLK	DPLL_VIDEO2
HDMI_CLK	DPLL_HDMI					
CLKOUTMUX[0]	CLKOUTMUX[0]					
TIMER7	TIMER7_ICLK	Int	266	IPU_L3_GICLK	CORE_X2_CLK	DPLL_CORE
	TIMER7_FCLK	Func	100	TIMER7_GFCLK	SYS_CLK1	OSC0
					FUNC_32K_CLK	OSC0
					SYS_CLK2	OSC1
					XREF_CLK0	XREF_CLK0
					XREF_CLK1	XREF_CLK1
					XREF_CLK2	XREF_CLK2
					XREF_CLK3	XREF_CLK3
					DPLL_ABE_X2_CLK	DPLL_ABE
					VIDEO1_CLK	DPLL_VIDEO1
					VIDEO2_CLK	DPLL_VIDEO2
HDMI_CLK	DPLL_HDMI					
CLKOUTMUX[0]	CLKOUTMUX[0]					
TIMER8	TIMER8_ICLK	Int	266	IPU_L3_GICLK	CORE_X2_CLK	DPLL_CORE
	TIMER8_FCLK	Func	100	TIMER8_GFCLK	SYS_CLK1	OSC0
					FUNC_32K_CLK	OSC0
					SYS_CLK2	OSC1
					XREF_CLK0	XREF_CLK0
					XREF_CLK1	XREF_CLK1
					XREF_CLK2	XREF_CLK2
					XREF_CLK3	XREF_CLK3
					DPLL_ABE_X2_CLK	DPLL_ABE
					VIDEO1_CLK	DPLL_VIDEO1
					VIDEO2_CLK	DPLL_VIDEO2
HDMI_CLK	DPLL_HDMI					
CLKOUTMUX[0]	CLKOUTMUX[0]					

**Table 5-6. Maximum Supported Frequency (continued)**

MODULE				CLOCK SOURCES		
INSTANCE NAME	INPUT CLOCK NAME	CLOCK TYPE	MAX. CLOCK ALLOWED (MHz)	PRCM CLOCK NAME	PLL / OSC / SOURCE NAME	PLL / OSC / SOURCE NAME
TIMER9	TIMER9_ICLK	Int	266	L4PER_L3_GICLK	CORE_X2_CLK	DPLL_CORE
	TIMER9_FCLK	Func	100	TIMER9_GFCLK	SYS_CLK1	OSC0
					FUNC_32K_CLK	OSC0
					SYS_CLK2	OSC1
					XREF_CLK0	XREF_CLK0
					XREF_CLK1	XREF_CLK1
					XREF_CLK2	XREF_CLK2
					XREF_CLK3	XREF_CLK3
					DPLL_ABE_X2_CLK	DPLL_ABE
					VIDEO1_CLK	DPLL_VIDEO1
VIDEO2_CLK	DPLL_VIDEO2					
HDMI_CLK	DPLL_HDMI					
TIMER10	TIMER10_ICLK	Int	266	L4PER_L3_GICLK	CORE_X2_CLK	DPLL_CORE
	TIMER10_FCLK	Func	100	TIMER10_GFCLK	SYS_CLK1	OSC0
					FUNC_32K_CLK	OSC0
					SYS_CLK2	OSC1
					XREF_CLK0	XREF_CLK0
					XREF_CLK1	XREF_CLK1
					XREF_CLK2	XREF_CLK2
					XREF_CLK3	XREF_CLK3
					DPLL_ABE_X2_CLK	DPLL_ABE
					VIDEO1_CLK	DPLL_VIDEO1
VIDEO2_CLK	DPLL_VIDEO2					
HDMI_CLK	DPLL_HDMI					
TIMER11	TIMER11_ICLK	Int	266	L4PER_L3_GICLK	CORE_X2_CLK	DPLL_CORE
	TIMER11_FCLK	Func	100	TIMER11_GFCLK	SYS_CLK1	OSC0
					FUNC_32K_CLK	OSC0
					SYS_CLK2	OSC1
					XREF_CLK0	XREF_CLK0
					XREF_CLK1	XREF_CLK1
					XREF_CLK2	XREF_CLK2
					XREF_CLK3	XREF_CLK3
					DPLL_ABE_X2_CLK	DPLL_ABE
					VIDEO1_CLK	DPLL_VIDEO1
VIDEO2_CLK	DPLL_VIDEO2					
HDMI_CLK	DPLL_HDMI					
TIMER12	TIMER12_ICLK	Int	38.4	WKUPAON_GICLK	SYS_CLK1	OSC0
	TIMER12_FCLK	Func	0.032	OSC_32K_CLK	DPLL_ABE_X2_CLK	DPLL_ABE
					RC_CLK	RC oscillator

**Table 5-6. Maximum Supported Frequency (continued)**

MODULE				CLOCK SOURCES		
INSTANCE NAME	INPUT CLOCK NAME	CLOCK TYPE	MAX. CLOCK ALLOWED (MHz)	PRCM CLOCK NAME	PLL / OSC / SOURCE NAME	PLL / OSC / SOURCE NAME
TIMER13	TIMER13_ICLK	Int	266	L4PER3_L3_GICLK	CORE_X2_CLK	DPLL_CORE
	TIMER13_FCLK	Func	100	TIMER13_GFCLK	SYS_CLK1	OSC0
					FUNC_32K_CLK	OSC0
					SYS_CLK2	OSC1
					XREF_CLK0	XREF_CLK0
					XREF_CLK1	XREF_CLK1
					XREF_CLK2	XREF_CLK2
					XREF_CLK3	XREF_CLK3
					DPLL_ABE_X2_CLK	DPLL_ABE
					VIDEO1_CLK	DPLL_VIDEO1
VIDEO2_CLK	DPLL_VIDEO2					
HDMI_CLK	DPLL_HDMI					
TIMER14	TIMER14_ICLK	Int	266	L4PER3_L3_GICLK	CORE_X2_CLK	DPLL_CORE
	TIMER14_FCLK	Func	100	TIMER14_GFCLK	SYS_CLK1	OSC0
					FUNC_32K_CLK	OSC0
					SYS_CLK2	OSC1
					XREF_CLK0	XREF_CLK0
					XREF_CLK1	XREF_CLK1
					XREF_CLK2	XREF_CLK2
					XREF_CLK3	XREF_CLK3
					DPLL_ABE_X2_CLK	DPLL_ABE
					VIDEO1_CLK	DPLL_VIDEO1
VIDEO2_CLK	DPLL_VIDEO2					
HDMI_CLK	DPLL_HDMI					
TIMER15	TIMER15_ICLK	Int	266	L4PER3_L3_GICLK	CORE_X2_CLK	DPLL_CORE
	TIMER15_FCLK	Func	100	TIMER15_GFCLK	SYS_CLK1	OSC0
					FUNC_32K_CLK	OSC0
					SYS_CLK2	OSC1
					XREF_CLK0	XREF_CLK0
					XREF_CLK1	XREF_CLK1
					XREF_CLK2	XREF_CLK2
					XREF_CLK3	XREF_CLK3
					DPLL_ABE_X2_CLK	DPLL_ABE
					VIDEO1_CLK	DPLL_VIDEO1
VIDEO2_CLK	DPLL_VIDEO2					
HDMI_CLK	DPLL_HDMI					

**Table 5-6. Maximum Supported Frequency (continued)**

MODULE				CLOCK SOURCES		
INSTANCE NAME	INPUT CLOCK NAME	CLOCK TYPE	MAX. CLOCK ALLOWED (MHz)	PRCM CLOCK NAME	PLL / OSC / SOURCE NAME	PLL / OSC / SOURCE NAME
TIMER16	TIMER16_ICLK	Int	266	L4PER3_L3_GICLK	CORE_X2_CLK	DPLL_CORE
	TIMER16_FCLK	Func	100	TIMER16_GFCLK	SYS_CLK1	OSC0
					FUNC_32K_CLK	OSC0
					SYS_CLK2	OSC1
					XREF_CLK0	XREF_CLK0
					XREF_CLK1	XREF_CLK1
					XREF_CLK2	XREF_CLK2
					XREF_CLK3	XREF_CLK3
					DPLL_ABE_X2_CLK	DPLL_ABE
					VIDEO1_CLK	DPLL_VIDEO1
VIDEO2_CLK	DPLL_VIDEO2					
HDMI_CLK	DPLL_HDMI					
TPCC	TPCC_GCLK	Int	266	L3MAIN1_L3_GICLK	CORE_X2_CLK	DPLL_CORE
TPTC1	TPTC0_GCLK	Int	266	L3MAIN1_L3_GICLK	CORE_X2_CLK	DPLL_CORE
TPTC2	TPTC1_GCLK	Int	266	L3MAIN1_L3_GICLK	CORE_X2_CLK	DPLL_CORE
UART1	UART1_FCLK	Func	48	UART1_GFCLK	FUNC_192M_CLK	DPLL_PER
	UART1_ICLK	Int	266	L4PER_L3_GICLK	CORE_X2_CLK	DPLL_CORE
UART2	UART2_FCLK	Func	48	UART2_GFCLK	FUNC_192M_CLK	DPLL_PER
	UART2_ICLK	Int	266	L4PER_L3_GICLK	CORE_X2_CLK	DPLL_CORE
UART3	UART3_FCLK	Func	48	UART3_GFCLK	FUNC_192M_CLK	DPLL_PER
	UART3_ICLK	Int	266	L4PER_L3_GICLK	CORE_X2_CLK	DPLL_CORE
UART4	UART4_FCLK	Func	48	UART4_GFCLK	FUNC_192M_CLK	DPLL_PER
	UART4_ICLK	Int	266	L4PER_L3_GICLK	CORE_X2_CLK	DPLL_CORE
UART5	UART5_FCLK	Func	48	UART5_GFCLK	FUNC_192M_CLK	DPLL_PER
	UART5_ICLK	Int	266	L4PER_L3_GICLK	CORE_X2_CLK	DPLL_CORE
UART6	UART6_FCLK	Func	48	UART6_GFCLK	FUNC_192M_CLK	DPLL_PER
	UART6_ICLK	Int	266	IPU_L3_GICLK	CORE_X2_CLK	DPLL_CORE
UART7	UART7_FCLK	Func	48	UART7_GFCLK	FUNC_192M_CLK	DPLL_PER
	UART7_ICLK	Int	266	L4PER2_L3_GICLK	CORE_X2_CLK	DPLL_CORE
UART8	UART8_FCLK	Func	48	UART8_GFCLK	FUNC_192M_CLK	DPLL_PER
	UART8_ICLK	Int	266	L4PER2_L3_GICLK	CORE_X2_CLK	DPLL_CORE
UART9	UART9_FCLK	Func	48	UART9_GFCLK	FUNC_192M_CLK	DPLL_PER
	UART9_ICLK	Int	266	L4PER2_L3_GICLK	CORE_X2_CLK	DPLL_CORE
UART10	UART10_FCLK	Func	48	UART10_GFCLK	FUNC_192M_CLK	DPLL_PER
	UART10_ICLK	Int	38.4	WKUPAON_GICLK	SYS_CLK1	OSC0
					DPLL_ABE_X2_CLK	DPLL_ABE
USB1	USB1_MICLK	Int	266	L3INIT_L3_GICLK	CORE_X2_CLK	DPLL_CORE
	USB3PHY_REF_CLK	Func	34.3	USB_LFPS_TX_GFCLK	CORE_USB_OTG_SS_LFPS_TX_CLK	DPLL_CORE
	USB2PHY1_TREF_CLK	Func	38.4	USB_OTG_SS_REF_CLK	SYS_CLK1	OSC0
	USB2PHY1_REF_CLK	Func	960	L3INIT_960M_GFCLK	L3INIT_960_GFCLK	DPLL_USB

**Table 5-6. Maximum Supported Frequency (continued)**

MODULE				CLOCK SOURCES		
INSTANCE NAME	INPUT CLOCK NAME	CLOCK TYPE	MAX. CLOCK ALLOWED (MHz)	PRCM CLOCK NAME	PLL / OSC / SOURCE NAME	PLL / OSC / SOURCE NAME
USB2	USB2_MICLK	Int	266	L3INIT_L3_GICLK	CORE_X2_CLK	DPLL_CORE
	USB2PHY2_TREF_CLK	Func	38.4	USB_OTG_SS_REF_CLK	SYS_CLK1	OSC0
	USB2PHY2_REF_CLK	Func	960	L3INIT_960M_GFCLK	L3INIT_960_GFCLK	DPLL_USB
USB_PHY1_CORE	USB2PHY1_WKUP_CLK	Func	0.032	COREAON_32K_GFCLK	SYS_CLK1/610	OSC0
USB_PHY2_CORE	USB2PHY2_WKUP_CLK	Func	0.032	COREAON_32K_GFCLK	SYS_CLK1/610	OSC0
USB_PHY3_CORE	USB3PHY_WKUP_CLK	Func	0.032	COREAON_32K_GFCLK	SYS_CLK1/610	OSC0
VIP1	L3_CLK_PROC_CLK	Int & Func	266	VIP1_GICLK	CORE_X2_CLK	DPLL_CORE
					CORE_ISS_MAIN_CLK	DPLL_CORE
VIP2	L3_CLK_PROC_CLK	Int & Func	266	VIP2_GICLK	CORE_X2_CLK	DPLL_CORE
					CORE_ISS_MAIN_CLK	DPLL_CORE
VPE	L3_CLK_PROC_CLK	Int & Func	300	VPE_GICLK	CORE_ISS_MAIN_CLK	DPLL_CORE
					VIDEO1_CLKOUT4	DPLL_VIDEO1
WD_TIMER1	PIOCPCLK	Int	38.4	WKUPAON_GICLK	SYS_CLK1	OSC0
					DPLL_ABE_X2_CLK	DPLL_ABE
	PITIMERCLK	Func	0.032	OSC_32K_CLK	RC_CLK	RC oscillator
WD_TIMER2	WD_TIMER2_ICLK	Int	38.4	WKUPAON_GICLK	SYS_CLK1	OSC0
					DPLL_ABE_X2_CLK	DPLL_ABE
	WD_TIMER2_FCLK	Func	0.032	WKUPAON_SYS_GFCLK	FUNC_32K_CLK	OSC0

## 5.6 Power Consumption Summary

### NOTE

Maximum power consumption for this SoC depends on the specific use conditions for the end system. Contact your TI representative for assistance in estimating maximum power consumption for the end system use case.

## 5.7 Electrical Characteristics

### NOTE

The data specified in [Section 5.7](#) through [Section 5.7.4](#) are subject to change.

### NOTE

The interfaces or signals described in [Section 5.7](#) through [Section 5.7.4](#) correspond to the interfaces or signals available in multiplexing mode 0 (Function 1).

All interfaces or signals multiplexed on the balls described in these tables have the same DC electrical characteristics, unless multiplexing involves a PHY/GPIO combination in which case different DC electrical characteristics are specified for the different multiplexing modes (Functions).

**Table 5-7. LVC MOS DDR DC Electrical Characteristics**

over operating free-air temperature range (unless otherwise noted)

PARAMETER		MIN	NOM	MAX	UNIT
<b>Signal Names in MUXMODE 0 (Single-Ended Signals):</b> ddr1_d[31:0], ddr1_a[15:0], ddr1_dqm[3:0], ddr1_ba[2:0], ddr1_csn[0], ddr1_cke, ddr1_odt[0], ddr1_casn, ddr1_rasn, ddr1_wen, ddr1_rst, ddr1_ecc_d[7:0], ddr1_dqm_ecc, ddr2_d[31:0], ddr2_a[15:0], ddr2_dqm[3:0], ddr2_ba[2:0], ddr2_csn[0], ddr2_cke, ddr2_odt[0], ddr2_casn, ddr2_rasn, ddr2_wen, ddr2_rst;					
<b>Balls:</b> AA28 / AA25 / AA26 / Y24 / AA24 / Y23 / Y22 / AA23 / Y20 / AB27 / Y19 / AC27 / AC28 / AB28 / W20 / V20 / AD25 / AC24 / AC25 / AE26 / AF28 / AG27 / AF27 / AC23 / AE23 / AF23 / AE24 / AF24 / AH26 / AG26 / AF26 / AF25 / AD18 / AE17 / AF18 / AC21 / AD22 / AD21 / AE22 / AF22 / AE21 / AE21 / AH22 / AF21 / AB19 / AC20 / AC19 / AD20 / AA27 / AC26 / AB23 / AD23 / AB18 / AE18 / AF17 / AH23 / AG22 / AE20 / AC18 / AF20 / AH21 / AG21 / Y26 / V25 / V24 / Y25 / W23 / W19 / V23 / W22 / V26 / M26 / M25 / M24 / M23 / L28 / L25 / L26 / L27 / J20 / K22 / J23 / L24 / L23 / K21 / K20 / L22 / J24 / J26 / J25 / G26 / H26 / H24 / H25 / H23 / E28 / E27 / F27 / F26 / F24 / F25 / G25 / E26 / U22 / R22 / T22 / N28 / P26 / N23 / N27 / P27 / N20 / P25 / P22 / P23 / R27 / R28 / R26 / R25 / M22 / K23 / G24 / F28 / U26 / U27 / U23 / P24 / U24 / R23 / U28 / T23 / U25 / R24;					
<b>Driver Mode</b>					
V <sub>OH</sub>	High-level output threshold (I <sub>OH</sub> = 0.1 mA)	0.9 × V <sub>DD</sub> <sup>(1)</sup>			V
V <sub>OL</sub>	Low-level output threshold (I <sub>OL</sub> = 0.1 mA)	0.1 × V <sub>DD</sub> <sup>(1)</sup>			V
C <sub>PAD</sub>	Pad capacitance (including package capacitance)			3	pF
Z <sub>O</sub>	Output impedance (drive strength)	I[2:0] = 000 (Imp80)	80		Ω
		I[2:0] = 001 (Imp60)	60		
		I[2:0] = 010 (Imp48)	48		
		I[2:0] = 011 (Imp40)	40		
		I[2:0] = 100 (Imp34)	34		
<b>Single-Ended Receiver Mode</b>					
V <sub>IH</sub>	High-level input threshold	DDR3/DDR3L	VREF <sup>(2)</sup> + 0.1	V <sub>DD</sub> <sup>(1)</sup> + 0.2	V
V <sub>IL</sub>	Low-level input threshold	DDR3/DDR3L	-0.2	VREF <sup>(2)</sup> - 0.1	V
V <sub>CM</sub>	Input common-mode voltage		VREF <sup>(2)</sup> - 10%V <sub>DD</sub> <sup>(1)</sup>	VREF <sup>(2)</sup> + 10%V <sub>DD</sub> <sup>(1)</sup>	V
C <sub>PAD</sub>	Pad capacitance (including package capacitance)			3	pF
<b>Signal Names in MUXMODE 0 (Differential Signals):</b> ddr1_dqs[3:0], ddr1_dqsn[3:0], ddr1_ck, ddr1_nck, ddr2_dqs[3:0], ddr2_dqsn[3:0], ddr2_ck, ddr2_nck, ddr1_dqs_ecc, ddr1_dqsn_ecc;					
<b>Bottom Balls:</b> Y28 / AD27 / AE27 / AH25 / Y27 / AD28 / AE28 / AG25 / AG24 / AH24 / M28 / K27 / H27 / G28 / M27 / K28 / H28 / G27 / T28 / T27 / V27 / V28					
<b>Driver Mode</b>					
V <sub>OH</sub>	High-level output threshold (I <sub>OH</sub> = 0.1 mA)	0.9 × V <sub>DD</sub> <sup>(1)</sup>			V
V <sub>OL</sub>	Low-level output threshold (I <sub>OL</sub> = 0.1 mA)	0.1 × V <sub>DD</sub> <sup>(1)</sup>			V
C <sub>PAD</sub>	Pad capacitance (including package capacitance)			3	pF
Z <sub>O</sub>	Output impedance (drive strength)	I[2:0] = 000 (Imp80)	80		Ω
		I[2:0] = 001 (Imp60)	60		
		I[2:0] = 010 (Imp48)	48		
		I[2:0] = 011 (Imp40)	40		
		I[2:0] = 100 (Imp34)	34		
<b>Single-Ended Receiver Mode</b>					
V <sub>IH</sub>	High-level input threshold	DDR3/DDR3L	VREF <sup>(2)</sup> + 0.1	V <sub>DD</sub> <sup>(1)</sup> + 0.2	V
V <sub>IL</sub>	Low-level input threshold	DDR3/DDR3L	-0.2	VREF <sup>(2)</sup> - 0.1	V
V <sub>CM</sub>	Input common-mode voltage		VREF <sup>(2)</sup> - 10%V <sub>DD</sub> <sup>(1)</sup>	VREF <sup>(2)</sup> + 10%V <sub>DD</sub> <sup>(1)</sup>	V



**Table 5-7. LVCMOS DDR DC Electrical Characteristics (continued)**

over operating free-air temperature range (unless otherwise noted)

PARAMETER		MIN	NOM	MAX	UNIT
C <sub>PAD</sub>	Pad capacitance (including package capacitance)			3	pF
<b>Differential Receiver Mode</b>					
V <sub>SWING</sub>	Input voltage swing	DDR3/DDR3L	0.2	V <sub>DDSD</sub> <sup>(1)</sup> + 0.4	V
V <sub>CM</sub>	Input common-mode voltage		V <sub>REF</sub> <sup>(2)</sup> - 10%V <sub>DDSD</sub> <sup>(1)</sup>	V <sub>REF</sub> <sup>(2)</sup> + 10%V <sub>DDSD</sub> <sup>(1)</sup>	
C <sub>PAD</sub>	Pad capacitance (including package capacitance)			3	pF

(1) V<sub>DDSD</sub> stands for corresponding power supply (that is, vdds\_dds1 or vdds\_dds2). For more information on the power supply name and the corresponding ball, see [Table 4-1](#), POWER [11] column.

(2) V<sub>REF</sub> stands for corresponding Reference Power Supply (that is, ddr1\_vref0 or ddr2\_vref0). For more information on the power supply name and the corresponding ball, see [Table 4-1](#), POWER [11] column.

(3) For more information on the I/O cell configurations (i[2:0], sr[1:0]), see the *Control Module* chapter in the device TRM.

**Table 5-8. Dual Voltage LVCMOS I2C DC Electrical Characteristics**

over operating free-air temperature range (unless otherwise noted)

PARAMETER		MIN	NOM	MAX	UNIT
<b>Signal Names in MUXMODE 0:</b> i2c1_sda, i2c1_scl, i2c2_sda, i2c2_scl;					
<b>Balls:</b> F17 / C20 / C21 / C25					
<b>I2C Standard Mode – 1.8 V</b>					
V <sub>IH</sub>	Input high-level threshold	0.7 × V <sub>DDSD</sub> <sup>(1)</sup>			V
V <sub>IL</sub>	Input low-level threshold		0.3 × V <sub>DDSD</sub> <sup>(1)</sup>		V
V <sub>hys</sub>	Hysteresis	0.1 × V <sub>DDSD</sub> <sup>(1)</sup>			V
I <sub>IN</sub>	Input current at each I/O pin with an input voltage between 0.1 × V <sub>DDSD</sub> to 0.9 × V <sub>DDSD</sub>			12	μA
I <sub>OZ</sub>	I <sub>OZ</sub> (I <sub>PAD</sub> Current) for BIDI cell. This current is contributed by the tristated driver leakage + input current of the Rx + weak pullup/pulldown leakage. PAD is swept from 0 to V <sub>DDSD</sub> and the Max(I <sub>PAD</sub> ) is measured and is reported as I <sub>OZ</sub>			12	μA
C <sub>IN</sub>	Input capacitance			10	pF
V <sub>OL3</sub>	Output low-level threshold open-drain at 3-mA sink current		0.2 × V <sub>DDSD</sub> <sup>(1)</sup>		V
I <sub>OLmin</sub>	Low-level output current @V <sub>OL</sub> = 0.2 × V <sub>DDSD</sub>	3			mA
t <sub>OF</sub>	Output fall time from V <sub>IHmin</sub> to V <sub>ILmax</sub> with a bus capacitance C <sub>B</sub> from 5 pF to 400 pF			250	ns
<b>I2C Fast Mode – 1.8 V</b>					
V <sub>IH</sub>	Input high-level threshold	0.7 × V <sub>DDSD</sub> <sup>(1)</sup>			V
V <sub>IL</sub>	Input low-level threshold		0.3 × V <sub>DDSD</sub> <sup>(1)</sup>		V
V <sub>hys</sub>	Hysteresis	0.1 × V <sub>DDSD</sub> <sup>(1)</sup>			V
I <sub>IN</sub>	Input current at each I/O pin with an input voltage between 0.1 × V <sub>DDSD</sub> to 0.9 × V <sub>DDSD</sub>			12	μA
I <sub>OZ</sub>	I <sub>OZ</sub> (I <sub>PAD</sub> Current) for BIDI cell. This current is contributed by the tristated driver leakage + input current of the Rx + weak pullup/pulldown leakage. PAD is swept from 0 to V <sub>DDSD</sub> and the Max(I <sub>PAD</sub> ) is measured and is reported as I <sub>OZ</sub>			12	μA
C <sub>IN</sub>	Input capacitance			10	pF
V <sub>OL3</sub>	Output low-level threshold open-drain at 3-mA sink current		0.2 × V <sub>DDSD</sub> <sup>(1)</sup>		V
I <sub>OLmin</sub>	Low-level output current @V <sub>OL</sub> = 0.2 × V <sub>DDSD</sub>	3			mA
t <sub>OF</sub>	Output fall time from V <sub>IHmin</sub> to V <sub>ILmax</sub> with a bus capacitance C <sub>B</sub> from 10 pF to 400 pF		20 + 0.1 × C <sub>B</sub>	250	ns
<b>I2C Standard Mode – 3.3 V</b>					

**Table 5-8. Dual Voltage LVCMOS I2C DC Electrical Characteristics (continued)**

over operating free-air temperature range (unless otherwise noted)

PARAMETER		MIN	NOM	MAX	UNIT
V <sub>IH</sub>	Input high-level threshold	0.7 × V <sub>DD5</sub> <sup>(1)</sup>			V
V <sub>IL</sub>	Input low-level threshold	0.3 × V <sub>DD5</sub> <sup>(1)</sup>			V
V <sub>hys</sub>	Hysteresis	0.05 × V <sub>DD5</sub> <sup>(1)</sup>			V
I <sub>IN</sub>	Input current at each I/O pin with an input voltage between 0.1 × V <sub>DD5</sub> to 0.9 × V <sub>DD5</sub>	31		80	μA
I <sub>OZ</sub>	I <sub>OZ</sub> (I <sub>PAD</sub> Current) for BIDI cell. This current is contributed by the tristated driver leakage + input current of the Rx + weak pullup/pulldown leakage. PAD is swept from 0 to V <sub>DD5</sub> and the Max(I <sub>PAD</sub> ) is measured and is reported as I <sub>OZ</sub>	31		80	μA
C <sub>IN</sub>	Input capacitance			10	pF
V <sub>OL3</sub>	Output low-level threshold open-drain at 3-mA sink current			0.4	V
I <sub>OLmin</sub>	Low-level output current @V <sub>OL</sub> = 0.4 V	3			mA
I <sub>OLmin</sub>	Low-level output current @V <sub>OL</sub> = 0.6 V for full drive load (400 pF / 400 kHz)	6			mA
t <sub>OF</sub>	Output fall time from V <sub>IHmin</sub> to V <sub>ILmax</sub> with a bus capacitance C <sub>B</sub> from 5 pF to 400 pF			250	ns
<b>I2C Fast Mode – 3.3 V</b>					
V <sub>IH</sub>	Input high-level threshold	0.7 × V <sub>DD5</sub> <sup>(1)</sup>			V
V <sub>IL</sub>	Input low-level threshold	0.3 × V <sub>DD5</sub> <sup>(1)</sup>			V
V <sub>hys</sub>	Hysteresis	0.05 × V <sub>DD5</sub> <sup>(1)</sup>			V
I <sub>IN</sub>	Input current at each I/O pin with an input voltage between 0.1 × V <sub>DD5</sub> to 0.9 × V <sub>DD5</sub>	31		80	μA
I <sub>OZ</sub>	I <sub>OZ</sub> (I <sub>PAD</sub> Current) for BIDI cell. This current is contributed by the tristated driver leakage + input current of the Rx + weak pullup/pulldown leakage. PAD is swept from 0 to V <sub>DD5</sub> and the Max(I <sub>PAD</sub> ) is measured and is reported as I <sub>OZ</sub>	31		80	μA
C <sub>IN</sub>	Input capacitance			10	pF
V <sub>OL3</sub>	Output low-level threshold open-drain at 3-mA sink current			0.4	V
I <sub>OLmin</sub>	Low-level output current @V <sub>OL</sub> = 0.4 V	3			mA
I <sub>OLmin</sub>	Low-level output current @V <sub>OL</sub> = 0.6 V for full drive load (400 pF / 400 kHz)	6			mA
t <sub>OF</sub>	Output fall time from V <sub>IHmin</sub> to V <sub>ILmax</sub> with a bus capacitance C <sub>B</sub> from 10 pF to 200 pF (Proper External Resistor Value should be used as per I2C spec)	20 + 0.1 × C <sub>B</sub>		250	ns
	Output fall time from V <sub>IHmin</sub> to V <sub>ILmax</sub> with a bus capacitance C <sub>B</sub> from 300 pF to 400 pF (Proper External Resistor Value should be used as per I2C spec)	40		290	

(1) V<sub>DD5</sub> stands for corresponding power supply (that is, vddshv3). For more information on the power supply name and the corresponding ball, see [Table 4-1, POWER \[11\]](#) column.

(2) For more information on the I/O cell configurations, see the *Control Module* chapter in the device TRM.

**Table 5-9. IQ1833 Buffers DC Electrical Characteristics**

over operating free-air temperature range (unless otherwise noted)

PARAMETER	MIN	NOM	MAX	UNIT
<b>Signal Names in MUXMODE 0:</b> tclk;				
<b>Balls:</b> E20;				
<b>1.8-V Mode</b>				

**Table 5-9. IQ1833 Buffers DC Electrical Characteristics (continued)**

over operating free-air temperature range (unless otherwise noted)

PARAMETER		MIN	NOM	MAX	UNIT
V <sub>IH</sub>	Input high-level threshold (Does not meet JEDEC V <sub>IH</sub> )	0.75 × V <sub>DD5</sub> <sup>(1)</sup>			V
V <sub>IL</sub>	Input low-level threshold (Does not meet JEDEC V <sub>IL</sub> )			0.25 × V <sub>DD5</sub> <sup>(1)</sup>	V
V <sub>HYS</sub>	Input hysteresis voltage	100			mV
I <sub>IN</sub>	Input current at each I/O pin	2		11	μA
C <sub>PAD</sub>	Pad capacitance (including package capacitance)			1	pF
<b>3.3-V Mode</b>					
V <sub>IH</sub>	Input high-level threshold (Does not meet JEDEC V <sub>IH</sub> )	2.0			V
V <sub>IL</sub>	Input low-level threshold (Does not meet JEDEC V <sub>IL</sub> )			0.6	V
V <sub>HYS</sub>	Input hysteresis voltage	400			mV
I <sub>IN</sub>	Input current at each I/O pin	5		11	μA
C <sub>PAD</sub>	Pad capacitance (including package capacitance)			1	pF

(1) V<sub>DD5</sub> stands for corresponding power supply (that is, vddshv3). For more information on the power supply name and the corresponding ball, see [Table 4-1](#), POWER [11] column.

**Table 5-10. IHHV1833 Buffers DC Electrical Characteristics**

over operating free-air temperature range (unless otherwise noted)

PARAMETER		MIN	NOM	MAX	UNIT
<b>Signal Names in MUXMODE 0:</b> porz / rtc_iso / rtc_porz / wakeup [3:0];					
<b>Balls:</b> F22 / AF14 / AB17 / AD17 / AC17 / AB16 / AC16;					
<b>1.8-V Mode</b>					
V <sub>IH</sub>	Input high-level threshold	1.2 <sup>(1)</sup>			V
V <sub>IL</sub>	Input low-level threshold			0.4	V
V <sub>HYS</sub>	Input hysteresis voltage	40			mV
I <sub>IN</sub>	Input current at each I/O pin	0.02		1	μA
C <sub>PAD</sub>	Pad capacitance (including package capacitance)			1	pF
<b>3.3-V Mode</b>					
V <sub>IH</sub>	Input high-level threshold	1.2 <sup>(1)</sup>			V
V <sub>IL</sub>	Input low-level threshold			0.4	V
V <sub>HYS</sub>	Input hysteresis voltage	40			mV
I <sub>IN</sub>	Input current at each I/O pin	5		8	μA
C <sub>PAD</sub>	Pad capacitance (including package capacitance)			1	pF

(1) The IHHV1833 buffer exists in the dual-voltage IO logic that can be powered by either 1.8 V or 3.3 V provided by vddshv3. However, the vddshv3 supply is only used for input protection circuitry, not for logic functionality. The logic in this buffer operates entirely on the vdds18v supply. Therefore, IHHV control is asserted whenever the input is low and vdds18v is valid.

**Table 5-11. LVC MOS OSC Buffers DC Electrical Characteristics**

over operating free-air temperature range (unless otherwise noted)

PARAMETER		MIN	NOM	MAX	UNIT
<b>Signal Names in MUXMODE 0:</b> rtc_osc_xi_clkin32 / rtc_osc_xo;					
<b>Balls:</b> AE14 / AD14;					
<b>1.8-V Mode</b>					
V <sub>IH</sub>	Input high-level threshold	0.65 × V <sub>DD5</sub> <sup>(1)</sup>			V
V <sub>IL</sub>	Input low-level threshold			0.35 × V <sub>DD5</sub> <sup>(1)</sup>	V
V <sub>HYS</sub>	Input hysteresis voltage	150			mV

**Table 5-11. LVCMOS OSC Buffers DC Electrical Characteristics (continued)**

over operating free-air temperature range (unless otherwise noted)

PARAMETER		MIN	NOM	MAX	UNIT
C <sub>PAD</sub>	Pad capacitance (including package capacitance)			3	pF

(1) VDD5 stands for corresponding power supply (that is, vdda\_etc). For more information on the power supply name and the corresponding ball, see [Table 4-1](#), POWER [11] column.

**Table 5-12. BC1833IHHV Buffers DC Electrical Characteristics**

over operating free-air temperature range (unless otherwise noted)

PARAMETER		MIN	NOM	MAX	UNIT
<b>Signal Names in MUXMODE 0:</b> on_off;					
<b>Balls:</b> Y11;					
<b>1.8-V Mode</b>					
V <sub>OH</sub>	Output high-level threshold (I <sub>OH</sub> = 2 mA)	VDD5 <sup>(1)</sup> - 0.45			V
V <sub>OL</sub>	Output low-level threshold (I <sub>OL</sub> = 2 mA)			0.45	V
I <sub>DRIVE</sub>	Pin Drive strength at PAD Voltage = 0.45 V or VDD5 - 0.45 V	6			mA
I <sub>IN</sub>	Input current at each I/O pin	6		12	μA
I <sub>OZ</sub>	I <sub>OZ</sub> (I <sub>PAD</sub> Current) for BIDI cell. This current is contributed by the tristated driver leakage + input current of the Rx + weak pullup/pulldown leakage. PAD is swept from 0 to VDD5 and the Max(I <sub>PAD</sub> ) is measured and is reported as I <sub>OZ</sub>			6	μA
C <sub>PAD</sub>	Pad capacitance (including package capacitance)			4	pF
<b>3.3-V Mode</b>					
V <sub>OH</sub>	Output high-level threshold (I <sub>OH</sub> = 100 μA)	VDD5 <sup>(1)</sup> - 0.2			V
V <sub>OL</sub>	Output low-level threshold (I <sub>OL</sub> = 100 μA)			0.2	V
I <sub>DRIVE</sub>	Pin Drive strength at PAD Voltage = 0.45 V or VDD5 - 0.45 V	6			mA
I <sub>IN</sub>	Input current at each I/O pin			60	μA
I <sub>OZ</sub>	I <sub>OZ</sub> (I <sub>PAD</sub> Current) for BIDI cell. This current is contributed by the tristated driver leakage + input current of the Rx + weak pullup/pulldown leakage. PAD is swept from 0 to VDD5 and the Max(I <sub>PAD</sub> ) is measured and is reported as I <sub>OZ</sub>			60	μA
C <sub>PAD</sub>	Pad capacitance (including package capacitance)			4	pF

(1) VDD5 stands for corresponding power supply (that is, vddshv5). For more information on the power supply name and the corresponding ball, see [Table 4-1](#), POWER [11] column.

**Table 5-13. Dual Voltage SDIO1833 DC Electrical Characteristics**

over operating free-air temperature range (unless otherwise noted)

PARAMETER		MIN	NOM	MAX	UNIT
<b>Signal Names in Mode 0:</b> mmc1_clk, mmc1_cmd, mmc1_dat[3:0];					
<b>Bottom Balls:</b> W6 / Y6 / AA6 / Y4 / AA5 / Y3					
<b>1.8-V Mode</b>					
V <sub>IH</sub>	Input high-level threshold	1.27			V
V <sub>IL</sub>	Input low-level threshold			0.58	V
V <sub>HYS</sub>	Input hysteresis voltage	50 <sup>(2)</sup>			mV
I <sub>IN</sub>	Input current at each I/O pin			30	μA
I <sub>OZ</sub>	I <sub>OZ</sub> (I <sub>PAD</sub> Current) for BIDI cell. This current is contributed by the tristated driver leakage + input current of the Rx + weak pullup/pulldown leakage. PAD is swept from 0 to VDD5 and the Max(I <sub>PAD</sub> ) is measured and is reported as I <sub>OZ</sub>			30	μA

**Table 5-13. Dual Voltage SDIO1833 DC Electrical Characteristics (continued)**

over operating free-air temperature range (unless otherwise noted)

PARAMETER		MIN	NOM	MAX	UNIT
$I_{IN}$ with pulldown enabled	Input current at each I/O pin with weak pulldown enabled measured when PAD = VDD5	50	120	210	$\mu$ A
$I_{IN}$ with pullup enabled	Input current at each I/O pin with weak pullup enabled measured when PAD = 0	60	120	200	$\mu$ A
$C_{PAD}$	Pad capacitance (including package capacitance)			5	pF
$V_{OH}$	Output high-level threshold ( $I_{OH} = 2$ mA)	1.4			V
$V_{OL}$	Output low-level threshold ( $I_{OL} = 2$ mA)			0.45	V
<b>3.3-V Mode</b>					
$V_{IH}$	Input high-level threshold	$0.625 \times VDD5^{(1)}$			V
$V_{IL}$	Input low-level threshold	$0.25 \times VDD5^{(1)}$			V
$V_{HYS}$	Input hysteresis voltage	40 <sup>(2)</sup>			mV
$I_{IN}$	Input current at each I/O pin			110	$\mu$ A
$I_{OZ}$	$I_{OZ}(I_{PAD}$ Current) for BIDI cell. This current is contributed by the tristated driver leakage + input current of the Rx + weak pullup/pulldown leakage. PAD is swept from 0 to VDD5 and the $Max(I(PAD))$ is measured and is reported as $I_{OZ}$			110	$\mu$ A
$I_{IN}$ with pulldown enabled	Input current at each I/O pin with weak pulldown enabled measured when PAD = VDD5	40	100	290	$\mu$ A
$I_{IN}$ with pullup enabled	Input current at each I/O pin with weak pullup enabled measured when PAD = 0	10	100	290	$\mu$ A
$C_{PAD}$	Pad capacitance (including package capacitance)			5	pF
$V_{OH}$	Output high-level threshold ( $I_{OH} = 2$ mA)	$0.75 \times VDD5^{(1)}$			V
$V_{OL}$	Output low-level threshold ( $I_{OL} = 2$ mA)			$0.125 \times VDD5^{(1)}$	V

(1) VDD5 stands for corresponding power supply (that is, vddshv8). For more information on the power supply name and the corresponding ball, see [Table 4-1](#), POWER [11] column.

(2) Hysteresis is enabled/disabled with CTRL\_CORE\_CONTROL\_HYST\_1.SDCARD\_HYST register.

**Table 5-14. Dual Voltage LVC MOS DC Electrical Characteristics**

over operating free-air temperature range (unless otherwise noted)

PARAMETER		MIN	NOM	MAX	UNIT
<b>1.8-V Mode</b>					
$V_{IH}$	Input high-level threshold	$0.65 \times VDD5^{(1)}$			V
$V_{IL}$	Input low-level threshold	$0.35 \times VDD5^{(1)}$			V
$V_{HYS}$	Input hysteresis voltage	100			mV
$V_{OH}$	Output high-level threshold ( $I_{OH} = 2$ mA)	$VDD5^{(1)} - 0.45$			V
$V_{OL}$	Output low-level threshold ( $I_{OL} = 2$ mA)	0.45			V
$I_{DRIVE}$	Pin Drive strength at PAD Voltage = 0.45 V or VDD5-0.45 V	6			mA
$I_{IN}$	Input current at each I/O pin			16	$\mu$ A
$I_{OZ}$	$I_{OZ}(I_{PAD}$ Current) for BIDI cell. This current is contributed by the tristated driver leakage + input current of the Rx + weak pullup/pulldown leakage. PAD is swept from 0 to VDD5 and the $Max(I_{PAD})$ is measured and is reported as $I_{OZ}$			16	$\mu$ A

**Table 5-14. Dual Voltage LVCMOS DC Electrical Characteristics (continued)**

over operating free-air temperature range (unless otherwise noted)

PARAMETER		MIN	NOM	MAX	UNIT
$I_{IN}$ with pulldown enabled	Input current at each I/O pin with weak pulldown enabled measured when PAD = VDD5	50	120	210	$\mu$ A
$I_{IN}$ with pullup enabled	Input current at each I/O pin with weak pullup enabled measured when PAD = 0	60	120	200	$\mu$ A
$C_{PAD}$	Pad capacitance (including package capacitance)			4	pF
$Z_O$	Output impedance (drive strength)		40		$\Omega$
<b>3.3-V Mode</b>					
$V_{IH}$	Input high-level threshold	2			V
$V_{IL}$	Input low-level threshold			0.8	V
$V_{HYS}$	Input hysteresis voltage	200			mV
$V_{OH}$	Output high-level threshold ( $I_{OH} = 100 \mu$ A)	VDD5 <sup>(1)</sup> - 0.2			V
$V_{OL}$	Output low-level threshold ( $I_{OL} = 100 \mu$ A)			0.2	V
$I_{DRIVE}$	Pin Drive strength at PAD Voltage = 0.45 V or VDD5-0.45 V	6			mA
$I_{IN}$	Input current at each I/O pin			65	$\mu$ A
$I_{OZ}$	$I_{OZ}(I_{PAD}$ Current) for BIDI cell. This current is contributed by the tristated driver leakage + input current of the Rx + weak pullup/pulldown leakage. PAD is swept from 0 to VDD5 and the Max( $I_{PAD}$ ) is measured and is reported as $I_{OZ}$			65	$\mu$ A
$I_{IN}$ with pulldown enabled	Input current at each I/O pin with weak pulldown enabled measured when PAD = VDD5	40	100	200	$\mu$ A
$I_{IN}$ with pullup enabled	Input current at each I/O pin with weak pullup enabled measured when PAD = 0	10	100	290	$\mu$ A
$C_{PAD}$	Pad capacitance (including package capacitance)			4	pF
$Z_O$	Output impedance (drive strength)		40		$\Omega$

(1) VDD5 stands for corresponding power supply. For more information on the power supply name and the corresponding ball, see [Table 4-1](#), POWER [11] column.

### 5.7.1 HDMIPHY DC Electrical Characteristics

#### NOTE

The HDMIPHY DC Electrical Characteristics are compliant with the HDMI 1.4a specification and are not reproduced here.

### 5.7.2 USBPHY DC Electrical Characteristics

#### NOTE

USB1 instance is compliant with the USB3.0 SuperSpeed Transmitter and Receiver Normative Electrical Parameters as defined in the USB3.0 Specification Rev 1.0 dated June 6, 2011.

#### NOTE

USB1 and USB2 Electrical Characteristics are compliant with USB2.0 Specification Rev 2.0 dated April 27, 2000 including ECNs and Errata as applicable.

### **5.7.3 SATAPHY DC Electrical Characteristics**

---

**NOTE**

The SATA module is compliant with the electrical parameters specified in the *SATA-IO SATA Specification*, Revision 3.2, August 7, 2013.

---

### **5.7.4 PCIEPHY DC Electrical Characteristics**

---

**NOTE**

The PCIe interfaces are compliant with the electrical parameters specified in *PCI-Express Base Specification* Revision 3.0.

---

## 5.8 VPP Specifications for One-Time Programmable (OTP) eFuses

This section specifies the operating conditions required for programming the OTP eFuses and is applicable only for High-Security Devices.

**Table 5-15. Recommended Operating Conditions for OTP eFuse Programming**

over operating free-air temperature range (unless otherwise noted)

PARAMETER	DESCRIPTION	MIN	NOM	MAX	UNIT
vdd_core	Supply voltage range for the core domain during OTP operation; OPP NOM (BOOT)	1.11	1.15	1.2	V
vpp	Supply voltage range for the eFuse ROM domain during normal operation	NC			V
	Supply voltage range for the eFuse ROM domain during OTP programming <sup>(1)(2)</sup>	1.8			V
I(vpp)		100			mA
T <sub>j</sub>	Temperature (junction)	0	25	85	°C

(1) Supply voltage range includes DC errors and peak-to-peak noise. TI power management solutions [TLV70718](#) from the TLV707x family meet the supply voltage range needed for vpp.

(2) During normal operation, no voltage should be applied to vpp. This can be typically achieved by disabling the regulator attached to the vpp terminal. For more details, see [TLV707](#), [TLV707P 200-mA, Low-I<sub>Q</sub>, Low-Noise, Low-Dropout Regulator for Portable Devices](#).

### 5.8.1 Hardware Requirements

The following hardware requirements must be met when programming keys in the OTP eFuses:

- The vpp power supply must be disabled when not programming OTP registers.
- The vpp power supply must be ramped up after the proper device power-up sequence (for more details, see [Section 5.10.3](#)).

### 5.8.2 Programming Sequence

Programming sequence for OTP eFuses:

- Power on the board per the power-up sequencing. No voltage should be applied on the vpp terminal during power up and normal operation.
- Load the OTP write software required to program the eFuse (contact your local TI representative for the OTP software package).
- Apply the voltage on the vpp terminal according to the specification in [Table 5-15](#).
- Run the software that programs the OTP registers.
- After validating the content of the OTP registers, remove the voltage from the vpp terminal.

### 5.8.3 Impact to Your Hardware Warranty

You accept that e-Fusing the TI Devices with security keys permanently alters them. You acknowledge that the e-Fuse can fail, for example, due to incorrect or aborted program sequence or if you omit a sequence step. Further the TI Device may fail to secure boot if the error code correction check fails for the Production Keys or if the image is not signed and optionally encrypted with the current active Production Keys. These types of situations will render the TI Device inoperable and TI will be unable to confirm whether the TI Devices conformed to their specifications prior to the attempted e-Fuse. CONSEQUENTLY, TI WILL HAVE NO LIABILITY (WARRANTY OR OTHERWISE) FOR ANY TI DEVICES THAT HAVE BEEN e-FUSED WITH SECURITY KEYS.

## 5.9 Thermal Characteristics

For reliability and operability concerns, the maximum junction temperature of the Device has to be at or below the T<sub>j</sub> value identified in [Section 5.4, Recommended Operating Conditions](#).



It is recommended to perform thermal simulations at the system level with the worst case device power consumption.

### 5.9.1 Package Thermal Characteristics

Table 5-16 provides the thermal resistance characteristics for the package used on this device.

#### NOTE

Power dissipation of 1.5 W and an ambient temperature of 85°C is assumed for ABZ package.

**Table 5-16. Thermal Resistance Characteristics**

NO.	PARAMETER	DESCRIPTION	°C/W <sup>(1) (3)</sup>	AIR FLOW (m/s) <sup>(2)</sup>
T1	R $\theta_{JC}$	Junction-to-case	0.16	N/A
T2	R $\theta_{JB}$	Junction-to-board	3.12	N/A
T3	R $\theta_{JA}$	Junction-to-free air	13.02	0
T4		Junction-to-moving air	7.71	1
T5			6.76	2
T6			6.24	3
T7	$\Psi_{JT}$	Junction-to-package top	0.09	0
T8			0.09	1
T9			0.09	2
T10			0.09	3
T11	$\Psi_{JB}$	Junction-to-board	2.88	0
T12			2.74	1
T13			2.67	2
T14			2.61	3

(1) These values are based on a JEDEC defined 2S2P system (with the exception of the Theta JC [R $\theta_{JC}$ ] value, which is based on a JEDEC defined 1S0P system) and will change based on environment as well as application. For more information, see these EIA/JEDEC standards:

- JESD51-2, *Integrated Circuits Thermal Test Method Environment Conditions - Natural Convection (Still Air)*
- JESD51-3, *Low Effective Thermal Conductivity Test Board for Leaded Surface Mount Packages*
- JESD51-6, *Integrated Circuit Thermal Test Method Environmental Conditions - Forced Convection (Moving Air)*
- JESD51-7, *High Effective Thermal Conductivity Test Board for Leaded Surface Mount Packages*
- JESD51-9, *Test Boards for Area Array Surface Mount Packages*

(2) m/s = meters per second.

(3) °C/W = degrees Celsius per watt.

## 5.10 Timing Requirements and Switching Characteristics

### 5.10.1 Timing Parameters and Information

The timing parameter symbols used in the timing requirement and switching characteristic tables are created in accordance with JEDEC Standard 100. To shorten the symbols, some of pin names and other related terminologies have been abbreviated as follows:

**Table 5-17. Timing Parameters**

SUBSCRIPTS	
SYMBOL	PARAMETER
c	Cycle time (period)
d	Delay time
dis	Disable time
en	Enable time
h	Hold time
su	Setup time
START	Start bit
t	Transition time
v	Valid time
w	Pulse duration (width)
X	Unknown, changing, or don't care level
F	Fall time
H	High
L	Low
R	Rise time
V	Valid
IV	Invalid
AE	Active Edge
FE	First Edge
LE	Last Edge
Z	High impedance

#### 5.10.1.1 Parameter Information

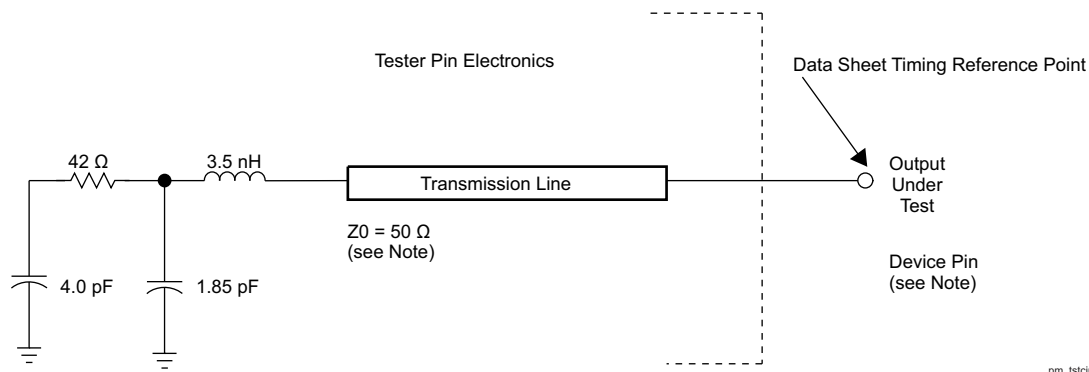

**Figure 5-2. Test Load Circuit for AC Timing Measurements**

The load capacitance value stated is only for characterization and measurement of AC timing signals.

This load capacitance value does not indicate the maximum load the device is capable of driving.

### 5.10.1.1.1 1.8V and 3.3V Signal Transition Levels

All input and output timing parameters are referenced to  $V_{ref}$  for both "0" and "1" logic levels.  $V_{ref} = (V_{DD} I/O) / 2$ .

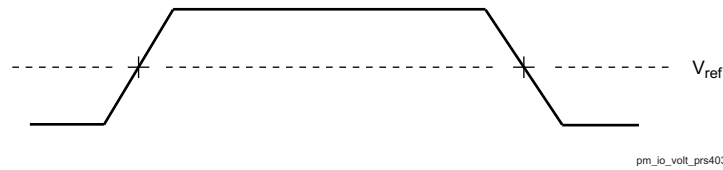

Figure 5-3. Input and Output Voltage Reference Levels for AC Timing Measurements

All rise and fall transition timing parameters are referenced to  $V_{IL} MAX$  and  $V_{IH} MIN$  for input clocks,  $V_{OL} MAX$  and  $V_{OH} MIN$  for output clocks.

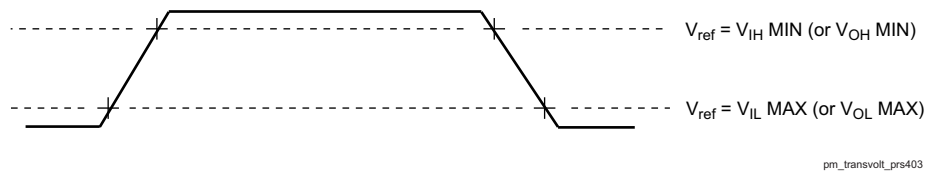

Figure 5-4. Rise and Fall Transition Time Voltage Reference Levels

### 5.10.1.1.2 1.8V and 3.3V Signal Transition Rates

The default SLEWCONTROL settings in each pad configuration register must be used to ensure timings, unless specific instructions otherwise are given in the individual timing sub-sections of the datasheet.

All timings are tested with an input edge rate of 4 volts per nanosecond (4 V/ns).

### 5.10.1.1.3 Timing Parameters and Board Routing Analysis

The timing parameter values specified in this Data Manual do not include delays by board routes. As a good board design practice, such delays must always be taken into account. Timing values may be adjusted by increasing/decreasing such delays. TI recommends using the available I/O buffer information specification (IBIS) models to analyze the timing characteristics correctly. To properly use IBIS models to attain accurate timing analysis for a given system, see the [Using IBIS Models for timing Analysis](#) application report. If needed, external logic hardware such as buffers may be used to compensate any timing differences.

## 5.10.2 Interface Clock Specifications

### 5.10.2.1 Interface Clock Terminology

The interface clock is used at the system level to sequence the data and/or to control transfers accordingly with the interface protocol.

### 5.10.2.2 Interface Clock Frequency

The two interface clock characteristics are:

- The maximum clock frequency
- The maximum operating frequency

The interface clock frequency defines the maximum limit supported by the device and does not take into account any system consideration (PCB, peripherals).

The system designer will have to consider these considerations and the device timing characteristics as well to define properly the maximum operating frequency that corresponds to the maximum frequency supported to transfer the data on this interface.

### 5.10.3 Power Supply Sequences

This section describes the power-up and power-down sequence required to ensure proper device operation. The power supply names described in this section comprise a superset of a family of compatible devices. Some members of this family will not include a subset of these power supplies and their associated device modules. Refer to the [Section 4.2, Pin Attributes](#) of the [Section 4, Terminal Configuration and Functions](#) to determine which power supplies are applicable.

---

#### NOTE

RTC-only mode is not a supported feature.

---

Figure 5-5 and Figure 5-6 describe the device power sequencing when RTC-mode is NOT used.

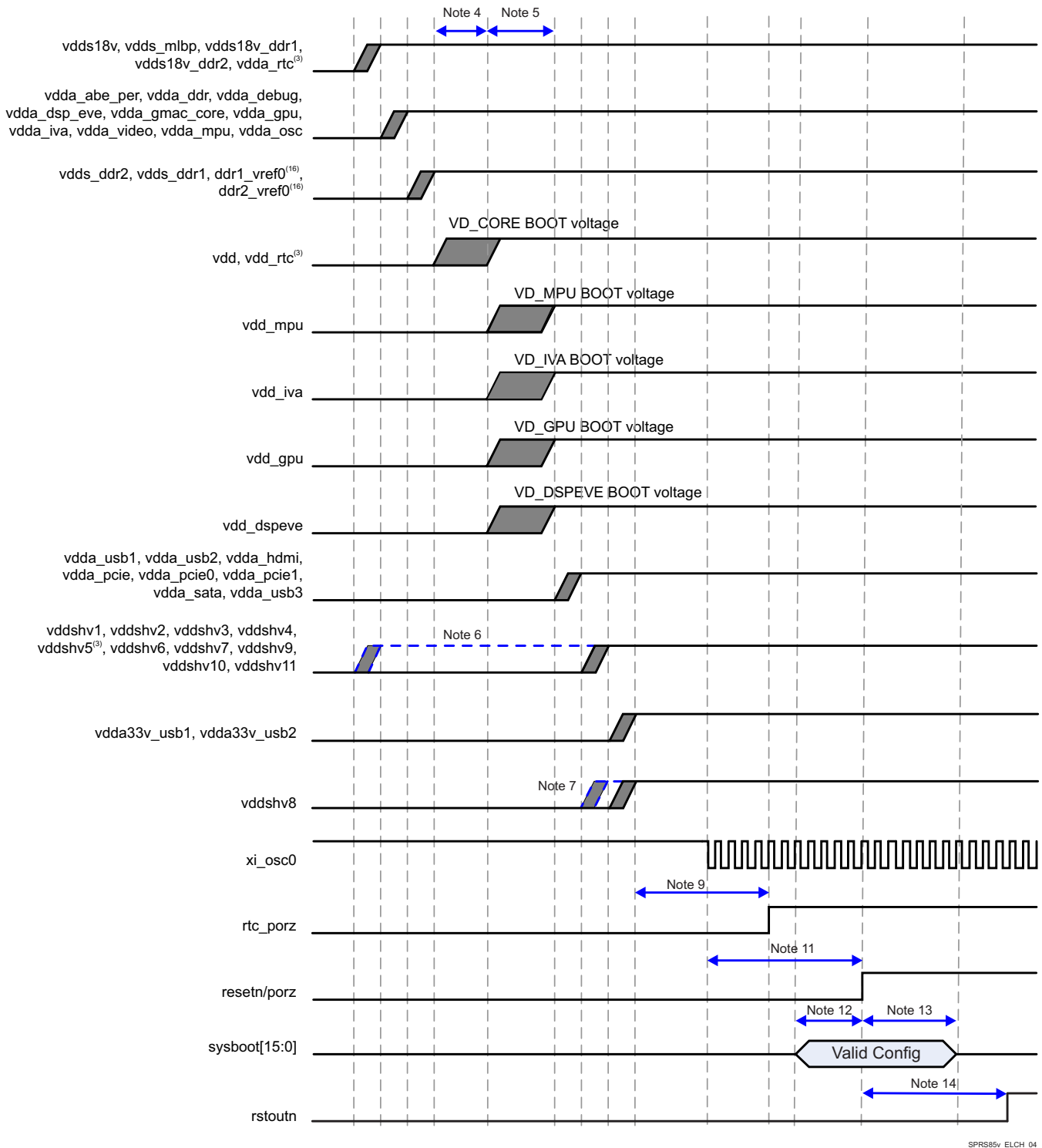
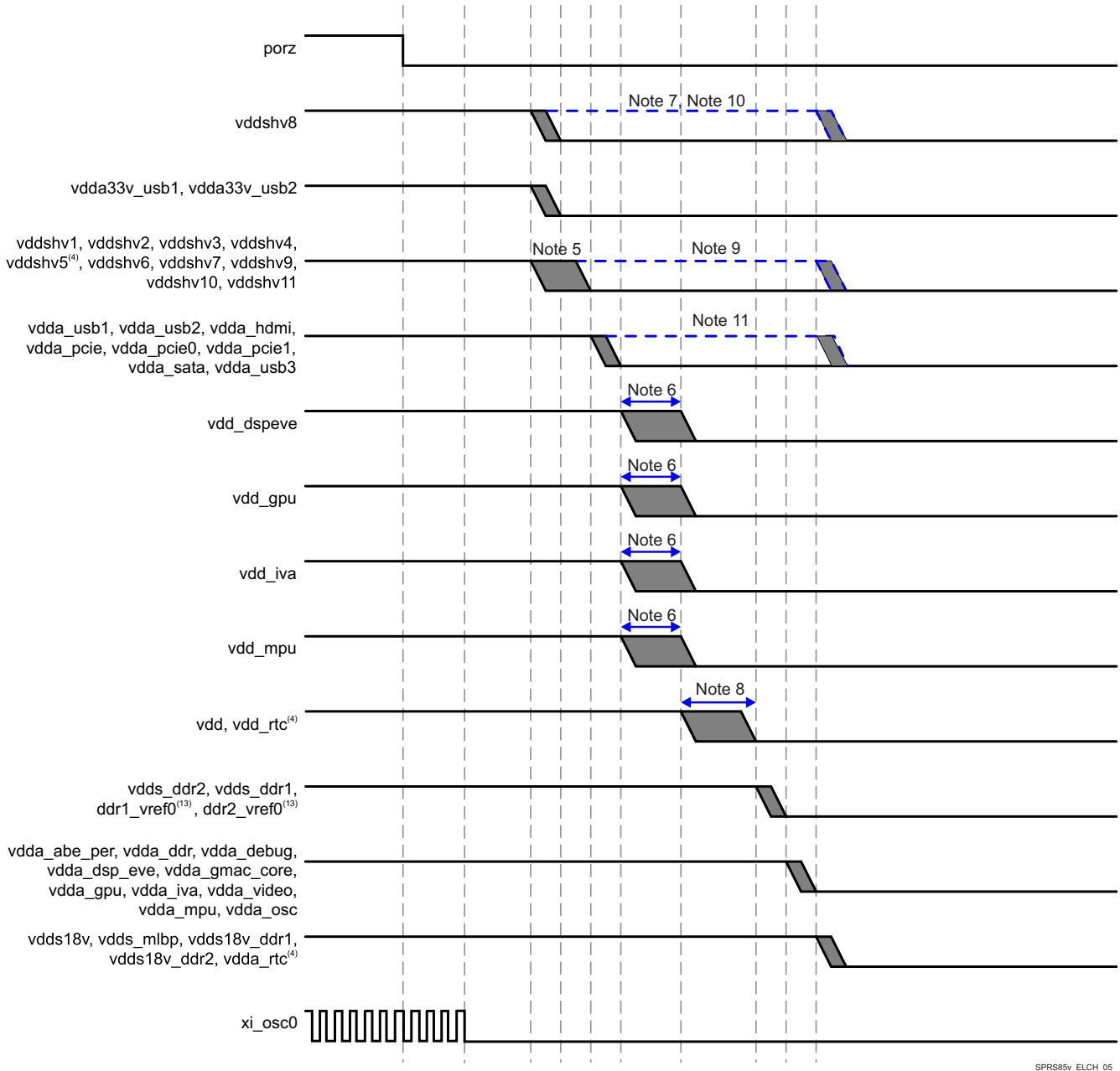

Figure 5-5. Power-Up Sequencing (2)

- (1) Grey shaded areas are windows where it is valid to ramp the voltage rail.
- (2) Blue dashed lines are not valid windows but show alternate ramp possibilities based on the associated note.
- (3) If RTC-only mode is not used then the following combinations are approved:
  - vdda\_rtc can be combined with vdds18v

- vdd\_rtc can be combined with vdd
  - vddshv5 can be combined with other 1.8 V or 3.3 V vddshvn rails.
- If combinations listed above are not followed then sequencing for these 3 voltage rails should follow the RTC mode timing requirements. When using RTC mode timing:
- vdda\_rtc rises coincident with, or before, the 1.8 V interface supplies (such as vdds18v).
  - vdd\_rtc rises coincident with vdd, or it may rise earlier. If rising earlier, it must rise after the 1.8 V interface supplies.
  - vddshv5 rises coincident with the other vddshvn rails (of the same voltage) or it can rise about the same time as the 1.8 V PHY supplies (such as vdd\_usb1).
- (4) vdd must ramp before or at the same time as vdd\_mpu, vdd\_gpu, vdd\_dspeve and vdd\_iva.
  - (5) vdd\_mpu, vdd\_gpu, vdd\_dspeve, vdd\_iva can be ramped at the same time or can be staggered.
  - (6) If any of the vddshv[1-7,9-11] rails (not including vddshv8) are used as 1.8 V only, then these rails can be combined with vdds18v.
  - (7) vddshv8 is separated out to show support for dual voltage. If single voltage is used then vddshv8 can be combined with other vddshvn rails but vddshv8 must ramp after vdd.
  - (8) vdds and vdda rails must not be combined together, with the one exception of vdda\_rtc when RTC-mode is not supported.
  - (9) Pulse duration: rtc\_porz must remain low 1 ms after vdda\_rtc, vddshv5, and vdd\_rtc are ramped and stable.
  - (10) The FUNC\_32K\_CLK source must be stable and at a valid frequency 1ms prior to deasserting rtc\_porz high.
  - (11) porz must remain asserted low until all of the following conditions are met:
    - All device supply rails reach stable operational levels.
    - xi\_osc0 is stable and at a valid frequency.
    - Minimum of 12P after both of the above conditions are met, where  $P = 1 / (\text{SYS\_CLK1}/610)$ , units in ns. resetn must be high prior to, or rise simultaneous with, porz but not before its power supply, vddshv3, rising.
  - (12) Setup time: sysboot[15:0] pins must be valid  $2P^{(15)}$  before porz is de-asserted high.
  - (13) Hold time: sysboot[15:0] pins must be valid  $15P^{(15)}$  after porz is de-asserted high.
  - (14) rstoutn will be asserted low when porz is low, and de-asserted following an internal 2ms delay. rstoutn is only valid after vddshv3 reaches an operational level. If used as a peripheral component reset, it should be AND gated with porz to avoid possible reset glitches during power up.
  - (15)  $P = 1 / (\text{SYS\_CLK1} / 610)$   $\mu\text{s}$ , where SYS\_CLK1 is in MHz.
  - (16) ddr1\_vref0 / ddr2\_vref0 may rise coincident with vdds\_ddr1 / vdds\_ddr2, respectively or at a later time. However, it must be valid before porz rising.



SPRS85v\_ELCH\_05

Figure 5-6. Power-Down Sequencing (12)(14)

- (1) Grey shaded areas are windows where it is valid to ramp the voltage rail.
- (2) Blue dashed lines are not valid windows but show alternate ramp possibilities based on the associated note.
- (3) xi\_osc0 can be turned off anytime after porz assertion and must be turned off before vdda\_osc voltage rail is shutdown.
- (4) If RTC-mode is not used then the following combinations are approved:
  - vdda\_rtc can be combined with vdds18v
  - vdd\_rtc can be combined with vdd
  - vddshv5 can be combined with other 1.8 V or 3.3 V vddshv\* rails
 If combinations listed above are not followed then sequencing for these 3 voltage rails should follow the RTC mode timing requirements. When using RTC mode timing:
  - vdda\_rtc falls coincident with, or later than, the 1.8 V interface supplies (such as vdds18v).
  - vdd\_rtc falls coincident with vdd, or it may fall later. If falling later, it must fall before, or coincident with, the 1.8 V interface supplies.
  - vddshv5 falls coincident with the other vddshvn rails (of the same voltage) or it can fall about the same time as the 1.8 V PHY supplies (such as vdd\_usb1).
- (5) vddshv\* domains supplied by 3.3 V:
  - must remain greater than 2.7 V to enable Dual Voltage GPIO selector circuit operation for 100 μs min after porz is asserted low.

- must be in first group of supplies ramping down after porz has been asserted low for 100  $\mu$ s min.
  - must not exceed vdds18v by more than 2 V during ramp down, see Figure 5-7 “vdds18v versus vddshv\* Discharge Relationship”.
- (6) vdd\_mpu, vdd\_gpu, vdd\_dspeve, vdd\_iva can be ramped at the same time or can be staggered.
- (7) vddshv8 domain:
- if SDIO operation is needed,
    - must be in first group of supplies to ramp down after porz has been asserted low for 100  $\mu$ s min.
    - must be sourced from independent power resource that can provide dual voltage (3.3 V / 1.8 V) operation as required to be compliant to SDIO specification
  - if SDIO operation is not needed,
    - must be grouped and ramped down with other vddshv\* domains as noted above.
- (8) vdd must ramp after or at the same time as vdd\_mpu, vdd\_gpu, vdd\_dspeve and vdd\_iva.
- (9) If any of the vddshv[1-7,9-11] rails (not including vddshv8) are used as 1.8 V only, then these rails can be combined with vdds18v. vddshv[1-7,9-11] is allowed to ramp down at either of the two points shown in the timing diagram in either 1.8 V mode or in 3.3 V mode. If vddshv[1-7,9-11] ramps down at the later time in the diagram then the board design must ensure that the vddshv[1-7,9-11] rail is never higher than 2.0 V above the vdds18v rail.
- (10) vddshv8 is separated out to show support for dual voltage. If a dedicated LDO/supply source is used for vddshv8, then vddshv8 ramp down should occur at one of the two earliest points in the timing diagram. If vddshv8 is powered by the same supply source as the other vddshv[1-7,9-11] rails, then it is allowed to ramp down at either of the last two points in the timing diagram.
- (11) The 1.8 V vdda\_\* supplies can either ramp down at the earlier time period shown or can be delayed to ramp down after the core supplies coincident with the vdds18v supply as long as porz is asserted (low) during the power down sequence.
- (12) The power down sequence shown is the most general case and is always valid. An accelerated power down sequence is also available but is only valid when porz is asserted (low). This accelerated power down sequence has been implemented in the companion PMIC that is recommended for use with this SoC. The accelerated sequence has porz go low first, then all 3.3 V supplies simultaneously second, core supplies, DDR supplies and DDR references simultaneously third and all 1.8 V supplies simultaneously last.
- (13) ddr1\_vref0 / ddr2\_vref0 may fall coincident with vdds\_dds1 / vdds\_dds2, respectively or at a prior time but after porz is asserted low.
- (14) Ramped Down is defined as reaching a voltage level of no more than 0.6 V.

Figure 5-7 describes the discharge relationship between vdds18v and vddshv\* power supplies during power-down.

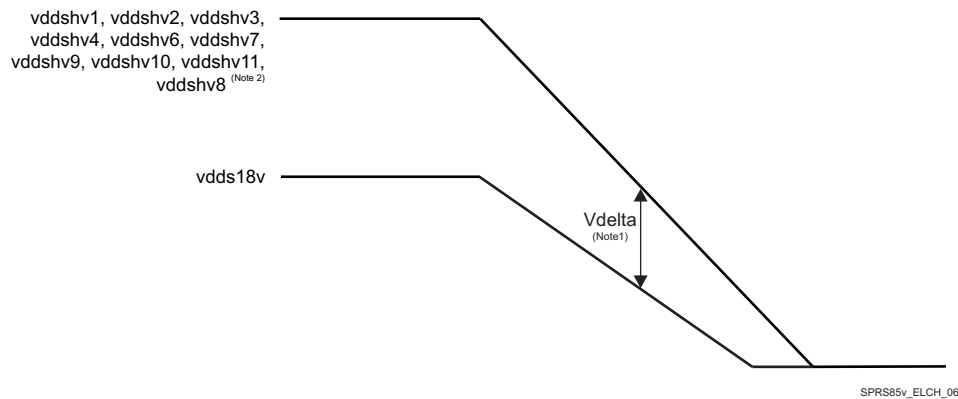

**Figure 5-7. vdds18v versus vddshv\* Discharge Relationship**

- (1) Vdelta MAX = 2 V
- (2) If vddshv8 is powered by the same supply source as the other vddshv[1-7,9-11] rails.

#### 5.10.4 Clock Specifications

---

##### NOTE

For more information, see *Power, Reset, and Clock Management* chapter in the device TRM.

---

##### NOTE

Audio Back End (ABE) module is not supported for this family of devices, but “ABE” name is still present in some clock or DPLL names.

---

The device operation requires the following clocks:



- The 32 kHz frequency is used for low frequency operation. It supplies the wake-up domain for operation in lowest power mode. This is an optional clock and will be supplied by on chip divider + mux (FUNC\_32K\_CLK) incase it is not available on external pin.
- The system clocks, SYS\_CLK1 (Mandatory) and SYS\_CLK2 (Optional) are the main clock sources of the device. They supply the reference clock to the DPLLs as well as functional clock to several modules.

The Device also embeds an internal free-running 32-kHz oscillator that is always active as long as the wake-up (WKUP) domain is supplied.

Figure 5-8 shows the external input clock sources and the output clocks to peripherals.

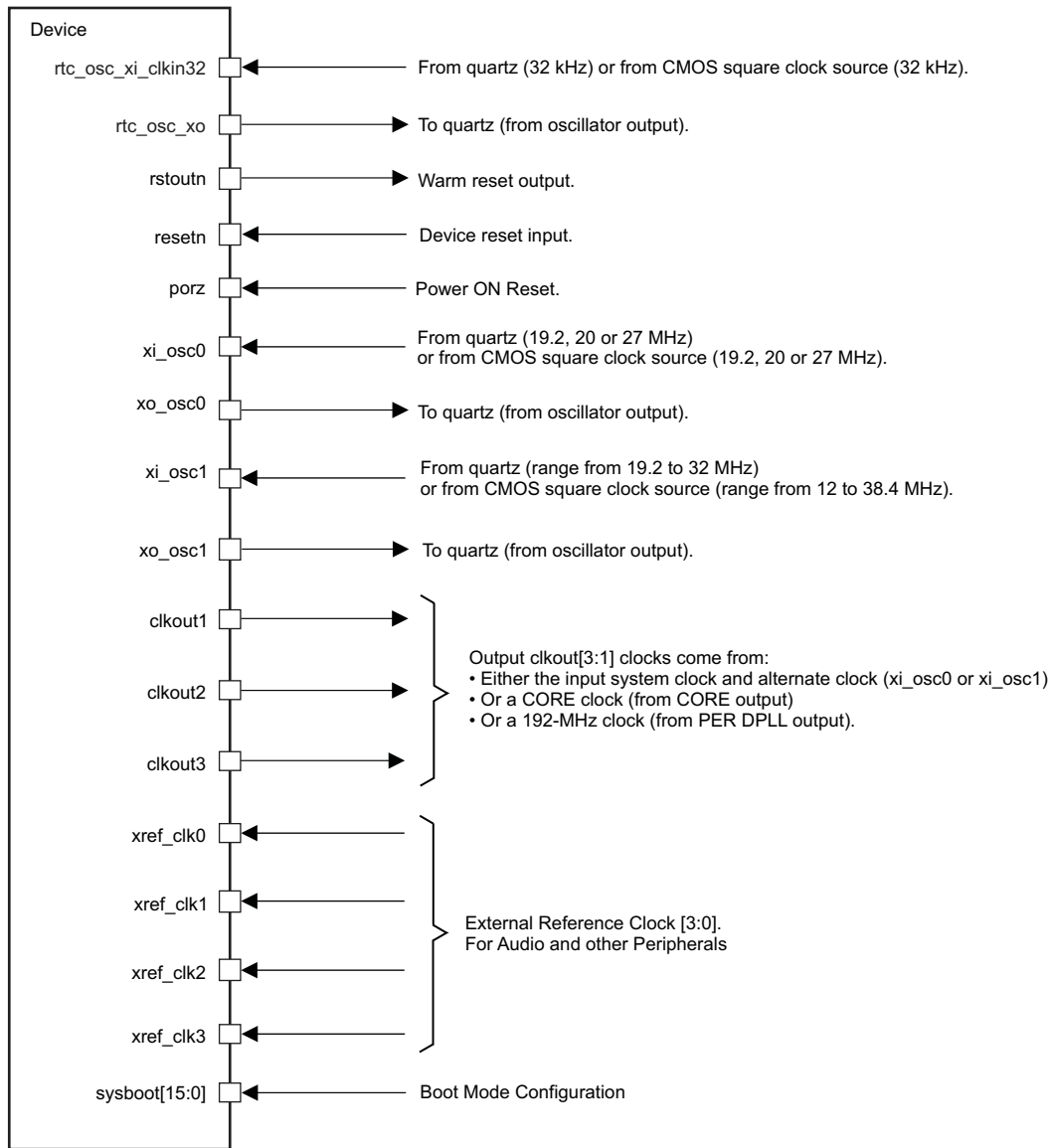

clock\_adas\_abc\_001

Figure 5-8. Clock Interface

### 5.10.4.1 Input Clocks / Oscillators

- The source of the internal system clock (SYS\_CLK1) could be either:
  - A CMOS clock that enters on the xi\_osc0 ball (with xo\_osc0 left unconnected on the CMOS clock case).
  - A crystal oscillator clock managed by xi\_osc0 and xo\_osc0.
- The source of the internal system clock (SYS\_CLK2) could be either:
  - A CMOS clock that enters on the xi\_osc1 ball (with xo\_osc1 left unconnected on the CMOS clock case).
  - A crystal oscillator clock managed by xi\_osc1 and xo\_osc1.
- The source of the internal system clock (FUNC\_32K\_CLK) could be either:
  - A CMOS clock that enters on the rtc\_osc\_xi\_clkin32 ball and supports external LVCMOS clock generators
  - A crystal oscillator clock managed by rtc\_osc\_xi\_clkin32 and rtc\_osc\_xo.

SYS\_CLK1 is received directly from oscillator OSC0. For more information about SYS\_CLK1, see *Power, Reset, and Clock Management* chapter in the device TRM.

#### 5.10.4.1.1 OSC0 External Crystal

An external crystal is connected to the device pins. [Figure 5-9](#) describes the crystal implementation.

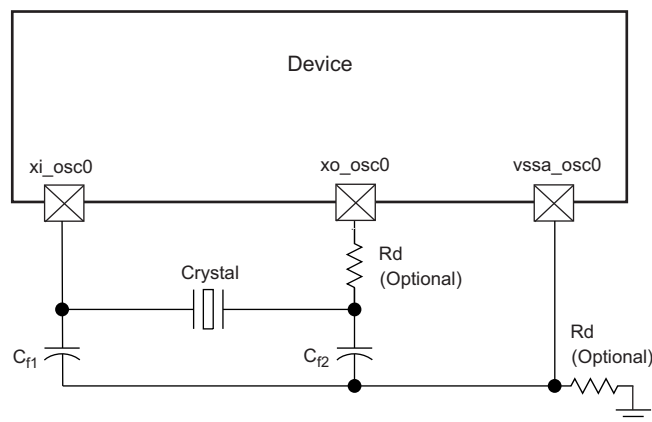

**Figure 5-9. Crystal Implementation**

#### NOTE

The load capacitors,  $C_{f1}$  and  $C_{f2}$  in [Figure 5-9](#), should be chosen such that the below equation is satisfied.  $C_L$  in the equation is the load specified by the crystal manufacturer. All discrete components used to implement the oscillator circuit should be placed as close as possible to the associated oscillator xi\_osc0, xo\_osc0, and vssa\_osc0 pins.

$$C_L = \frac{C_{f1} C_{f2}}{C_{f1} + C_{f2}}$$

**Figure 5-10. Load Capacitance Equation**

The crystal must be in the fundamental mode of operation and parallel resonant. [Table 5-18](#) summarizes the required electrical constraints.

**Table 5-18. OSC0 Crystal Electrical Characteristics**

NAME	DESCRIPTION		MIN	TYP	MAX	UNIT
$f_p$	Parallel resonance crystal frequency			19.2, 20, 27		MHz
$C_{f1}$	$C_{f1}$ load capacitance for crystal parallel resonance with $C_{f1} = C_{f2}$		12		24	pF
$C_{f2}$	$C_{f2}$ load capacitance for crystal parallel resonance with $C_{f1} = C_{f2}$		12		24	pF
ESR( $C_{f1}, C_{f2}$ )	Crystal ESR				100	$\Omega$
$C_O$	Crystal shunt capacitance	ESR = 30 $\Omega$ ESR = 40 $\Omega$	19.2 MHz, 20 MHz, 27 MHz		7	pF
		ESR = 50 $\Omega$	19.2 MHz, 20 MHz		7	pF
			27 MHz		5	pF
		ESR = 60 $\Omega$	19.2 MHz, 20 MHz		7	pF
			27 MHz		Not Supported	-
		ESR = 80 $\Omega$	19.2 MHz, 20 MHz 27 MHz		5	pF
ESR = 100 $\Omega$	19.2 MHz, 20 MHz 27 MHz		3	pF		
$L_M$	Crystal motional inductance for $f_p = 20$ MHz			10.16		mH
$C_M$	Crystal motional capacitance			3.42		fF
$t_{j(xi_osc0)}$	Frequency accuracy <sup>(1)</sup> , xi_osc0	Ethernet not used		$\pm 200$		ppm
		Ethernet RGMII and RMII using derived clock		$\pm 50$		
		Ethernet MII using derived clock		$\pm 100$		

(1) Crystal characteristics should account for tolerance+stability+aging.

When selecting a crystal, the system design must consider the temperature and aging characteristics of a based on the worst case environment and expected life expectancy of the system.

[Table 5-19](#) details the switching characteristics of the oscillator and the requirements of the input clock.

**Table 5-19. Oscillator Switching Characteristics—Crystal Mode**

NAME	DESCRIPTION	MIN	TYP	MAX	UNIT
$f_p$	Oscillation frequency		19.2, 20, 27		MHz
$t_{sX}$	Start-up time			4	ms

#### 5.10.4.1.2 OSC0 Input Clock

A 1.8-V LVCMOS-compatible clock input can be used instead of the internal oscillator to provide the SYS\_CLK1 clock input to the system. The external connections to support this are shown in [Figure 5-11](#). The xi\_osc0 pin is connected to the 1.8-V LVCMOS-compatible clock source. The xi\_osc0 pin is left unconnected. The vssa\_osc0 pin is connected to board ground (VSS).

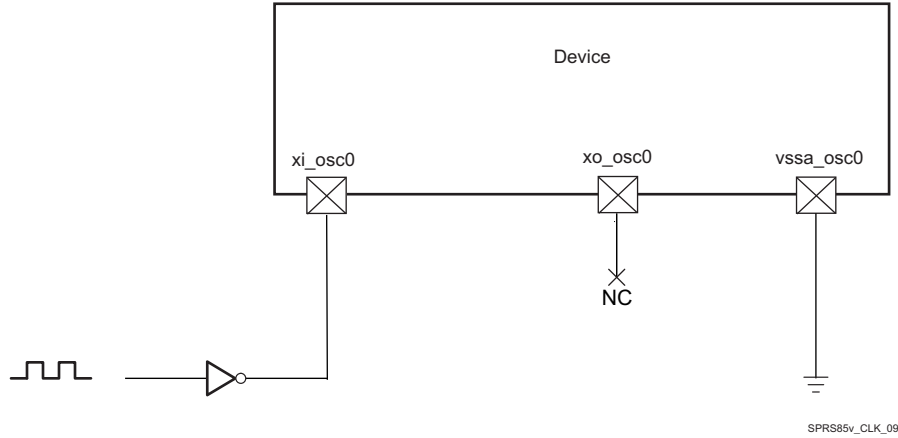

Figure 5-11. 1.8-V LVCMOS-Compatible Clock Input

Table 5-20 summarizes the OSC0 input clock electrical characteristics.

Table 5-20. OSC0 Input Clock Electrical Characteristics—Bypass Mode

NAME	DESCRIPTION	MIN	TYP	MAX	UNIT
f	Frequency		19.2, 20, or 27		MHz
C <sub>in</sub>	Input capacitance	2.184	2.384	2.584	pF
I <sub>in</sub>	Input current (3.3 V mode)	4	6	10	μA

Table 5-21 details the OSC0 input clock timing requirements.

Table 5-21. OSC0 Input Clock Timing Requirements

NAME	DESCRIPTION		MIN	TYP	MAX	UNIT
CK0	1 / t <sub>c(xi_osc0)</sub>	Frequency, xi_osc0		19.2, 20, 27		MHz
CK1	t <sub>w(xi_osc0)</sub>	Pulse duration, xi_osc0 low or high	0.45 × t <sub>c(xi_osc0)</sub>	0.55 × t <sub>c(xi_osc0)</sub>		ns
	t <sub>j(xi_osc0)</sub>	Period jitter <sup>(1)</sup> , xi_osc0		0.01 × t <sub>c(xi_osc0)</sub>		ns
	t <sub>R(xi_osc0)</sub>	Rise time, xi_osc0			5	ns
	t <sub>F(xi_osc0)</sub>	Fall time, xi_osc0			5	ns
	t <sub>j(xi_osc0)</sub>	Frequency accuracy <sup>(2)</sup> , xi_osc0	Ethernet not used		±200	ppm
			Ethernet RGMII and RMII using derived clock		±50	
			Ethernet MII using derived clock		±100	

(1) Period jitter is meant here as follows:

- The maximum value is the difference between the longest measured clock period and the expected clock period
- The minimum value is the difference between the shortest measured clock period and the expected clock period

(2) Crystal characteristics should account for tolerance+stability+aging.

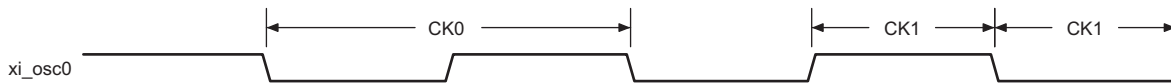

Figure 5-12. xi\_osc0 Input Clock

### 5.10.4.1.3 Auxiliary Oscillator OSC1 Input Clock

SYS\_CLK2 is received directly from oscillator OSC1. For more information about SYS\_CLK2, see *Power, Reset, and Clock Management* chapter in the device TRM.

#### 5.10.4.1.3.1 OSC1 External Crystal

An external crystal is connected to the device pins. [Figure 5-13](#) describes the crystal implementation.

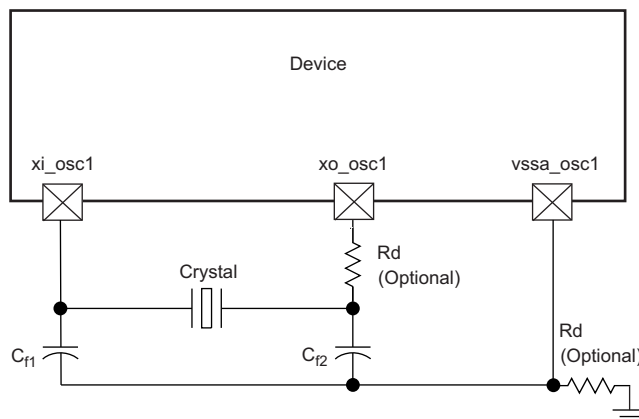

**Figure 5-13. Crystal Implementation**

#### NOTE

The load capacitors,  $C_{f1}$  and  $C_{f2}$  in [Figure 5-13](#), should be chosen such that the below equation is satisfied.  $C_L$  in the equation is the load specified by the crystal manufacturer. All discrete components used to implement the oscillator circuit should be placed as close as possible to the associated oscillator  $xi\_osc1$ ,  $xo\_osc1$ , and  $vssa\_osc1$  pins.

$$C_L = \frac{C_{f1} C_{f2}}{C_{f1} + C_{f2}}$$

**Figure 5-14. Load Capacitance Equation**

The crystal must be in the fundamental mode of operation and parallel resonant. [Table 5-22](#) summarizes the required electrical constraints.

**Table 5-22. OSC1 Crystal Electrical Characteristics**

NAME	DESCRIPTION	MIN	TYP	MAX	UNIT
$f_p$	Parallel resonance crystal frequency	Range from 19.2 to 32			MHz
$C_{f1}$	$C_{f1}$ load capacitance for crystal parallel resonance with $C_{f1} = C_{f2}$	12		24	pF
$C_{f2}$	$C_{f2}$ load capacitance for crystal parallel resonance with $C_{f1} = C_{f2}$	12		24	pF
$ESR(C_{f1}, C_{f2})$	Crystal ESR			100	$\Omega$

**Table 5-22. OSC1 Crystal Electrical Characteristics (continued)**

NAME	DESCRIPTION	MIN	TYP	MAX	UNIT	
C <sub>O</sub>	Crystal shunt capacitance	ESR = 30 Ω	19.2 MHz ≤ f <sub>p</sub> ≤ 32 MHz		7	pF
		ESR = 40 Ω	19.2 MHz ≤ f <sub>p</sub> ≤ 32 MHz		5	pF
		ESR = 50 Ω	19.2 MHz ≤ f <sub>p</sub> ≤ 25 MHz		7	pF
			25 MHz < f <sub>p</sub> ≤ 27 MHz		5	pF
			27 MHz < f <sub>p</sub> ≤ 32 MHz		Not Supported	-
		ESR = 60 Ω	19.2 MHz ≤ f <sub>p</sub> ≤ 23 MHz		7	pF
			23 MHz < f <sub>p</sub> ≤ 25 MHz		5	pF
			25 MHz < f <sub>p</sub> ≤ 32 MHz		Not Supported	-
		ESR = 80 Ω	19.2 MHz ≤ f <sub>p</sub> ≤ 23 MHz		5	pF
			23 MHz ≤ f <sub>p</sub> ≤ 25 MHz		3	pF
			25 MHz < f <sub>p</sub> ≤ 32 MHz		Not Supported	-
		ESR = 100 Ω	19.2 MHz ≤ f <sub>p</sub> ≤ 20 MHz		3	pF
20 MHz < f <sub>p</sub> ≤ 32 MHz			Not Supported	-		
L <sub>M</sub>	Crystal motional inductance for f <sub>p</sub> = 20 MHz		10.16		mH	
C <sub>M</sub>	Crystal motional capacitance		3.42		fF	
t <sub>j(xi_osc1)</sub>	Frequency accuracy <sup>(1)</sup> , xi_osc1	Ethernet not used		±200	ppm	
		Ethernet RGMII and RMII using derived clock		±50		
		Ethernet MII using derived clock		±100		

(1) Crystal characteristics should account for tolerance+stability+aging.

When selecting a crystal, the system design must take into account the temperature and aging characteristics of a crystal versus the user environment and expected lifetime of the system.

Table 5-23 details the switching characteristics of the oscillator and the requirements of the input clock.

**Table 5-23. Oscillator Switching Characteristics—Crystal Mode**

NAME	DESCRIPTION	MIN	TYP	MAX	UNIT
f <sub>p</sub>	Oscillation frequency		Range from 19.2 to 32		MHz
t <sub>sX</sub>	Start-up time			4	ms

#### 5.10.4.1.3.2 OSC1 Input Clock

A 1.8-V LVCMOS-compatible clock input can be used instead of the internal oscillator to provide the SYS\_CLK2 clock input to the system. The external connections to support this are shown in Figure 5-15. The xi\_osc1 pin is connected to the 1.8-V LVCMOS-compatible clock sources. The xo\_osc1 pin is left unconnected. The vssa\_osc1 pin is connected to board ground (VSS).

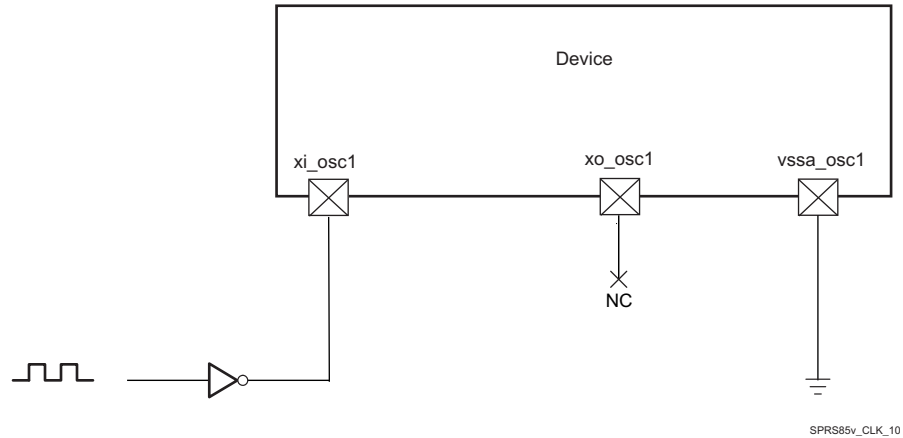

Figure 5-15. 1.8-V LVCMOS-Compatible Clock Input

Table 5-24 summarizes the OSC1 input clock electrical characteristics.

Table 5-24. OSC1 Input Clock Electrical Characteristics—Bypass Mode

NAME	DESCRIPTION	MIN	TYP	MAX	UNIT
f	Frequency		Range from 12 to 38.4		MHz
C <sub>I</sub>	Input capacitance	2.819	3.019	3.219	pF
I <sub>I</sub>	Input current (3.3 V mode)	4	6	10	μA
t <sub>sX</sub>	Start-up time <sup>(1)</sup>			See <sup>(2)</sup>	ms

- (1) To switch from bypass mode to crystal or from crystal mode to bypass mode, there is a waiting time about 100 μs; however, if the chip comes from bypass mode to crystal mode the crystal will start-up after time mentioned in Table 5-23, t<sub>sX</sub> parameter.
- (2) Before the processor boots up and the oscillator is set to bypass mode, there is a waiting time when the internal oscillator is in application mode and receives a wave. The switching time in this case is about 100 μs.

Table 5-25 details the OSC1 input clock timing requirements.

Table 5-25. OSC1 Input Clock Timing Requirements

NAME	DESCRIPTION	MIN	TYP	MAX	UNIT
CK0	1 / t <sub>c(xiosc1)</sub> Frequency, xi_osc1		Range from 12 to 38.4		MHz
CK1	t <sub>w(xiosc1)</sub> Pulse duration, xi_osc1 low or high	0.45 × t <sub>c(xiosc1)</sub>		0.55 × t <sub>c(xiosc1)</sub>	ns
	t <sub>j(xiosc1)</sub> Period jitter <sup>(1)</sup> , xi_osc1			0.01 × t <sub>c(xiosc1)</sub> <sup>(3)</sup>	ns
	t <sub>R(xiosc1)</sub> Rise time, xi_osc1			5	ns
	t <sub>F(xiosc1)</sub> Fall time, xi_osc1			5	ns
	t <sub>f(xiosc1)</sub> Frequency accuracy <sup>(2)</sup> , xi_osc1			±200	ppm
		Ethernet RGMII and RMII using derived clock		±50	
		Ethernet MII using derived clock		±100	

- (1) Period jitter is meant here as follows:
- The maximum value is the difference between the longest measured clock period and the expected clock period
  - The minimum value is the difference between the shortest measured clock period and the expected clock period
- (2) Crystal characteristics should account for tolerance+stability+aging.
- (3) The Period jitter requirement for OSC1 can be relaxed to 0.02 × t<sub>c(xiosc1)</sub> under the following constraints:
- a. The OSC1/SYS\_CLK2 clock bypasses all device PLLs
  - b. The OSC1/SYS\_CLK2 clock is only used to source the DSS pixel clock outputs

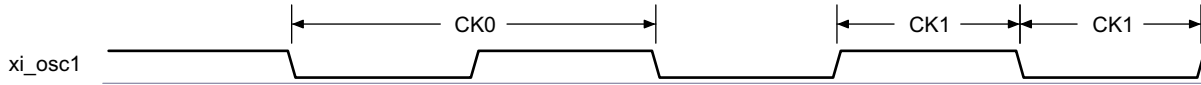

Figure 5-16. xi\_osc1 Input Clock

5.10.4.1.4 RTC Oscillator Input Clock

FUNC\_32K\_CLK is received directly from RTC oscillator. For more information about FUNC\_32K\_CLK, see *Power, Reset, and Clock Management* chapter in the device TRM.

**NOTE**

RTC-only mode is not a supported feature.

5.10.4.1.4.1 RTC Oscillator External Crystal

An external crystal is connected to the device pins. Figure 5-17 describes the crystal implementation.

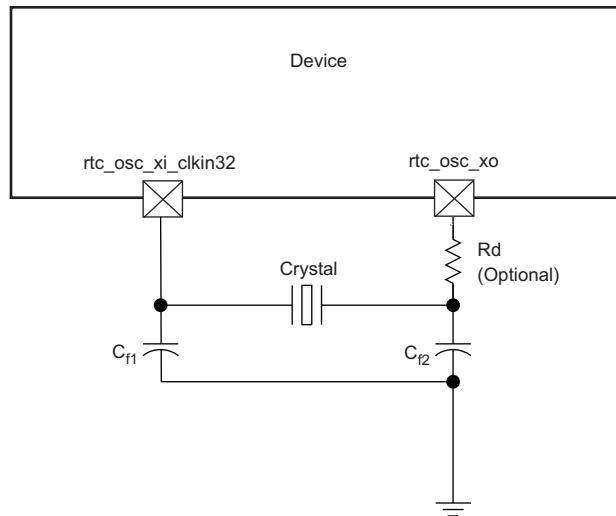

Figure 5-17. Crystal Implementation

**NOTE**

The load capacitors,  $C_{f1}$  and  $C_{f2}$  in Figure 5-17, should be chosen such that the below equation is satisfied.  $C_L$  in the equation is the load specified by the crystal manufacturer. All discrete components used to implement the oscillator circuit should be placed as close as possible to the associated oscillator  $rtc\_osc\_xi\_clkln32$  and  $rtc\_osc\_xo$  pins.

$$C_L = \frac{C_{f1} C_{f2}}{(C_{f1} + C_{f2})}$$

Figure 5-18. Load Capacitance Equation

The crystal must be in the fundamental mode of operation and parallel resonant. Table 5-26 summarizes the required electrical constraints.

Table 5-26. RTC Crystal Electrical Characteristics

NAME	DESCRIPTION	MIN	TYP	MAX	UNIT
$f_p$	Parallel resonance crystal frequency			32.768	kHz



**Table 5-26. RTC Crystal Electrical Characteristics (continued)**

NAME	DESCRIPTION	MIN	TYP	MAX	UNIT
C <sub>f1</sub>	C <sub>f1</sub> load capacitance for crystal parallel resonance with C <sub>f1</sub> = C <sub>f2</sub>	12		24	pF
C <sub>f2</sub>	C <sub>f2</sub> load capacitance for crystal parallel resonance with C <sub>f1</sub> = C <sub>f2</sub>	12		24	pF
ESR(C <sub>f1</sub> ,C <sub>f2</sub> )	Crystal ESR			80	kΩ
C <sub>O</sub>	Crystal shunt capacitance			5	pF
L <sub>M</sub>	Crystal motional inductance for f <sub>p</sub> = 32.768 kHz		10.7		mH
C <sub>M</sub>	Crystal motional capacitance		2.2		fF
t <sub>j</sub> (rtc_osc_xi_clkin32)	Frequency accuracy, rtc_osc_xi_clkin32			±200	ppm

When selecting a crystal, the system design must take into account the temperature and aging characteristics of a crystal versus the user environment and expected lifetime of the system.

Table 5-27 details the switching characteristics of the oscillator and the requirements of the input clock.

**Table 5-27. Oscillator Switching Characteristics—Crystal Mode**

NAME	DESCRIPTION	MIN	TYP	MAX	UNIT
f <sub>p</sub>	Oscillation frequency			32.768	kHz
t <sub>sX</sub>	Start-up time			4	ms

**5.10.4.1.4.2 RTC Oscillator Input Clock**

A 1.8-V LVCMOS-compatible clock input can be used instead of the internal oscillator to provide the FUNC\_32K\_CLK clock input to the system. The external connections to support this are shown in Figure 5-19. The rtc\_osc\_xi\_clkin32 pin is connected to the 1.8-V LVCMOS-compatible clock sources. The rtc\_osc\_xo pin is left unconnected.

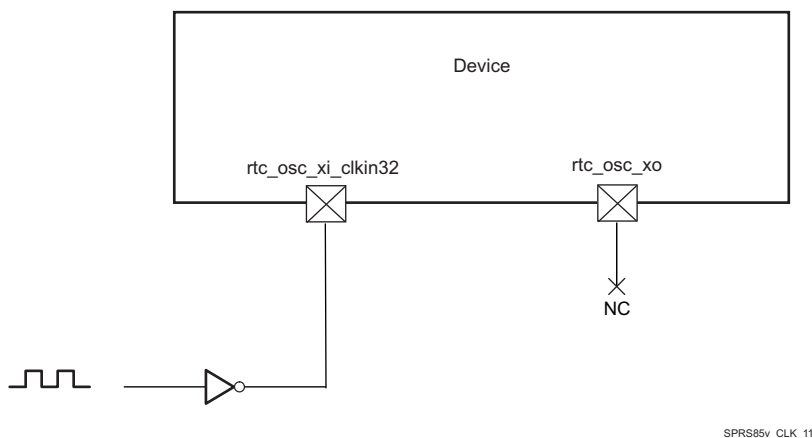

**Figure 5-19. LVCMOS-Compatible Clock Input**

Table 5-28 summarizes the RTC oscillator input clock electrical characteristics.

**Table 5-28. RTC Oscillator Input Clock Electrical Characteristics—Bypass Mode**

NAME	DESCRIPTION	MIN	TYP	MAX	UNIT
CK0	1 / t <sub>c</sub> (rtc_osc_xi_clkin32) Frequency, rtc_osc_xi_clkin32			32.768	kHz
CK1	t <sub>w</sub> (rtc_osc_xi_clkin32) Pulse duration, rtc_osc_xi_clkin32 low or high	0.45 × t <sub>c</sub> (rtc_osc_xi_clkin32)		0.55 × t <sub>c</sub> (rtc_osc_xi_clkin32)	ns
	C <sub>IN</sub> Input capacitance	2.178	2.378	2.578	pF
	I <sub>IN</sub> Input current (3.3 V mode)	4	6	10	μA
	t <sub>sX</sub> Start-up time			See (1)	ms

- (1) Before the processor boots up and the oscillator is set to bypass mode, there is a waiting time when the internal oscillator is in application mode and receives a wave. The switching time in this case is about 100  $\mu$ s.

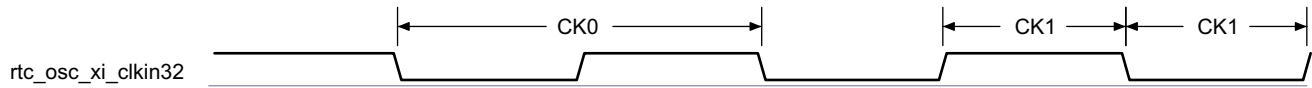

**Figure 5-20. rtc\_osc\_xi\_clk32 Input Clock**

#### 5.10.4.2 RC On-die Oscillator Clock

##### NOTE

The OSC\_32K\_CLK clock, provided by the On-die 32K RC oscillator, inside of the SoC, is not accurate 32 kHz clock.

The frequency may significantly vary with temperature and silicon characteristics.

For more information about OSC\_32K\_CLK, see *Power, Reset, and Clock Management* chapter in the device TRM.

### 5.10.4.3 Output Clocks

The device provides three output clocks. Summary of these output clocks are as follows:

- clkout1 - Device Clock output 1. Can be used as a system clock for other devices. The source of the clkout1 could be either:
  - The input system clock and alternate clock (xi\_osc0 or xi\_osc1)
  - CORE clock (from CORE output)
  - 192-MHz clock (from PER DPLL output)
- clkout2 - Device Clock output 2. Can be used as a system clock for other devices. The source of the clkout2 could be either:
  - The input system clock and alternate clock (xi\_osc0 or xi\_osc1)
  - CORE clock (from CORE output)
  - 192-MHz clock (from PER DPLL output)
- clkout3 - Device Clock output 3. Can be used as a system clock for other devices. The source of the clkout3 could be either:
  - The input system clock and alternate clock (xi\_osc0 or xi\_osc1)
  - CORE clock (from CORE output)
  - 192-MHz clock (from PER DPLL output)

For more information about output clocks, see *Power, Reset, and Clock Management* chapter in the device TRM.

### 5.10.4.4 DPLLs, DLLs

---

#### NOTE

For more information, see *Power, Reset, and Clock Management* and *Display Subsystem* chapters in the device TRM.

---

To generate high-frequency clocks, the device supports multiple on-chip DPLLs controlled directly by the PRCM module. They are of two types: type A and type B DPLLs.

- They have their own independent power domain (each one embeds its own switch and can be controlled as an independent functional power domain)
- They are fed with ALWAYS ON system clock, with independent control per DPLL.

The different DPLLs managed by the PRCM are listed below:

- DPLL\_MPU: It supplies the MPU subsystem clocking internally.
- DPLL\_IVA: It feeds the IVA subsystem clocking.
- DPLL\_CORE: It supplies all interface clocks and also few module functional clocks.
- DPLL\_PER: It supplies several clock sources: a 192-MHz clock for the display functional clock, a 96-MHz functional clock to subsystems and peripherals.
- DPLL\_ABE: It provides clocks to various modules within the device.
- DPLL\_USB: It provides 960M clock for USB modules (USB1/2/3/4).
- DPLL\_GMAC: It supplies several clocks for the Gigabit Ethernet Switch (GMAC\_SW).
- DPLL\_DSP: It feeds the DSP Subsystem clocking.
- DPLL\_GPU: It supplies clock for the GPU Subsystem.
- DPLL\_DDR: It generates clocks for the two External Memory Interface (EMIF) controllers and their associated EMIF PHYs.
- DPLL\_PCIE\_REF: It provides reference clock for the APLL\_PCIE in PCIE Subsystem.
- APLL\_PCIE: It feeds clocks for the device Peripheral Component Interconnect Express (PCIe) controllers.

**NOTE**

The following DPLLs are controlled by the clock manager located in the always-on Core power domain (CM\_CORE\_AON):

- DPLL\_MPU, DPLL\_IVA, DPLL\_CORE, DPLL\_ABE, DPLL\_DDR, DPLL\_GMAC, DPLL\_PCIE\_REF, DPLL\_PER, DPLL\_USB, DPLL\_DSP, DPLL\_GPU, APLL\_PCIE\_REF.

For more information on CM\_CORE\_AON and CM\_CORE or PRCM DPLLs, see *Power, Reset, and Clock Management* chapter in the device TRM.

The following DPLLs are not managed by the PRCM:

- DPLL\_VIDEO1; (It is controlled from DSS)
- DPLL\_VIDEO2; (It is controlled from DSS)
- DPLL\_HDMI; (It is controlled from DSS)
- DPLL\_SATA; (It is controlled from SATA)
- DPLL\_DEBUG; (It is controlled from DEBUGSS)
- DPLL\_USB\_OTG\_SS; (It is controlled from OCP2SCP1)

**NOTE**

For more information for not controlled from PRCM DPLL's see the related chapters in the Device TRM.

**5.10.4.4.1 DPLL Characteristics**

The DPLL has three relevant input clocks. One of them is the reference clock (CLKINP) used to generate the synthesized clock but can also be used as the bypass clock whenever the DPLL enters a bypass mode. It is therefore mandatory. The second one is a fast bypass clock (CLKINPULOW) used when selected as the bypass clock and is optional. The third clock (CLKINPHIF) is explained in the next paragraph.

The DPLL has three output clocks (namely CLKOUT, CLKOUTX2, and CLKOUTHIF). CLKOUT and CLKOUTX2 run at the bypass frequency whenever the DPLL enters a bypass mode. Both of them are generated from the lock frequency divided by a post-divider (namely M2 post-divider). The third clock, CLKOUTHIF, has no automatic bypass capability. It is an output of a post-divider (M3 post-divider) with the input clock selectable between the internal lock clock (Fdpll) and CLKINPHIF input of the PLL through an asynchronous multiplexing.

For more information, see *Power, Reset, and Clock Management* chapter in the device TRM.

[Table 5-29](#) summarizes DPLL type described in [Section 5.10.4.4](#), *DPLLs, DLLs Specifications* introduction.

**Table 5-29. DPLL Control Type**

DPLL NAME	TYPE	CONTROLLED BY PRCM
DPLL_ABE	<a href="#">Table 5-30</a> (Type A)	Yes
DPLL_CORE	<a href="#">Table 5-30</a> (Type A)	Yes <sup>(1)</sup>
DPLL_DEBUGSS	<a href="#">Table 5-30</a> (Type A)	No <sup>(1)</sup>
DPLL_DSP	<a href="#">Table 5-30</a> (Type A)	Yes <sup>(1)</sup>
DPLL_GMAC	<a href="#">Table 5-30</a> (Type A)	Yes <sup>(1)</sup>
DPLL_HDMI	<a href="#">Table 5-31</a> (Type B)	No <sup>(1)</sup>
DPLL_IVA	<a href="#">Table 5-30</a> (Type A)	Yes <sup>(1)</sup>
DPLL_MPU	<a href="#">Table 5-30</a> (Type A)	Yes <sup>(1)</sup>
DPLL_PER	<a href="#">Table 5-30</a> (Type A)	Yes <sup>(1)</sup>

**Table 5-29. DPLL Control Type (continued)**

DPLL NAME	TYPE	CONTROLLED BY PRCM
APLL_PCIE	<a href="#">Table 5-30</a> (Type A)	Yes <sup>(1)</sup>
DPLL_PCIE_REF	<a href="#">Table 5-31</a> (Type B)	Yes <sup>(1)</sup>
DPLL_SATA	<a href="#">Table 5-31</a> (Type B)	No <sup>(1)</sup>
DPLL_USB	<a href="#">Table 5-31</a> (Type B)	Yes <sup>(1)</sup>
DPLL_USB_OTG_SS	<a href="#">Table 5-31</a> (Type B)	No <sup>(1)</sup>
DPLL_VIDEO1	<a href="#">Table 5-30</a> (Type A)	No <sup>(1)</sup>
DPLL_VIDEO2	<a href="#">Table 5-30</a> (Type A)	No <sup>(1)</sup>
DPLL_DDR	<a href="#">Table 5-30</a> (Type A)	Yes <sup>(1)</sup>
DPLL_GPU	<a href="#">Table 5-30</a> (Type A)	Yes <sup>(1)</sup>

(1) DPLL is in the always-on domain.

[Table 5-30](#) and [Table 5-31](#) summarize the DPLL characteristics and assume testing over recommended operating conditions.

**Table 5-30. DPLL Type A Characteristics**

NAME	DESCRIPTION	MIN	TYP	MAX	UNIT	COMMENTS
$f_{input}$	CLKINP input frequency	0.032		52	MHz	$F_{INP}$
$f_{internal}$	Internal reference frequency	0.15		52	MHz	REFCLK
$f_{CLKINPHIF}$	CLKINPHIF input frequency	10		1400	MHz	$F_{INPHIF}$
$f_{CLKINPULOW}$	CLKINPULOW input frequency	0.001		600	MHz	Bypass mode: $f_{CLKOUT} = f_{CLKINPULOW} / (M1 + 1)$ if $ulowclken = 1$ <sup>(6)</sup>
$f_{CLKOUT}$	CLKOUT output frequency	20 <sup>(1)</sup>		1800 <sup>(2)</sup>	MHz	$[M / (N + 1)] \times F_{INP} \times [1 / M2]$ (in locked condition)
$f_{CLKOUTx2}$	CLKOUTx2 output frequency	40 <sup>(1)</sup>		2200 <sup>(2)</sup>	MHz	$2 \times [M / (N + 1)] \times F_{INP} \times [1 / M2]$ (in locked condition)
$f_{CLKOUTHIF}$	CLKOUTHIF output frequency			20 <sup>(3)</sup>	MHz	$F_{INPHIF} / M3$ if $clkinphifsel = 1$
				40 <sup>(3)</sup>	MHz	$2 \times [M / (N + 1)] \times F_{INP} \times [1 / M3]$ if $clkinphifsel = 0$
$f_{CLKDCOLDO}$	DCOCLKLDO output frequency	40		2800	MHz	$2 \times [M / (N + 1)] \times F_{INP}$ (in locked condition)
$t_{lock}$	Frequency lock time			$6 + 350 \times$ REFCLK	$\mu s$	
$p_{lock}$	Phase lock time			$6 + 500 \times$ REFCLK	$\mu s$	
$t_{relock-L}$	Relock time—Frequency lock <sup>(5)</sup> (LP relock time from bypass)			$6 + 70 \times$ REFCLK	$\mu s$	DPLL in LP relock time: $lowcurrstdby = 1$
$p_{relock-L}$	Relock time—Phase lock <sup>(5)</sup> (LP relock time from bypass)			$6 + 120 \times$ REFCLK	$\mu s$	DPLL in LP relock time: $lowcurrstdby = 1$
$t_{relock-F}$	Relock time—Frequency lock <sup>(5)</sup> (fast relock time from bypass)			$3.55 + 70 \times$ REFCLK	$\mu s$	DPLL in fast relock time: $lowcurrstdby = 0$
$p_{relock-F}$	Relock time—Phase lock <sup>(5)</sup> (fast relock time from bypass)			$3.55 + 120 \times$ REFCLK	$\mu s$	DPLL in fast relock time: $lowcurrstdby = 0$

(1) The minimum frequencies on CLKOUT and CLKOUTX2 are assuming  $M2 = 1$ .

For  $M2 > 1$ , the minimum frequency on these clocks will further scale down by factor of  $M2$ .

(2) The maximum frequencies on CLKOUT and CLKOUTX2 are assuming  $M2 = 1$ .

(3) The minimum frequency on CLKOUTHIF is assuming  $M3 = 1$ . For  $M3 > 1$ , the minimum frequency on this clock will further scale down by factor of  $M3$ .

(4) The maximum frequency on CLKOUTHIF is assuming  $M3 = 1$ .

(5) Relock time assumes typical operating conditions, 10°C maximum temperature drift.

(6) Bypass mode:  $f_{CLKOUT} = F_{INP}$  if  $ULOWCLKEN = 0$ . For more information, see the device TRM.

**Table 5-31. DPLL Type B Characteristics**

NAME	DESCRIPTION	MIN	TYP	MAX	UNIT	COMMENTS
$f_{input}$	CLKINP input clock frequency	0.62		60	MHz	$F_{INP}$
$f_{internal}$	REFCLK internal reference clock frequency	0.62		2.5	MHz	$[1 / (N + 1)] \times F_{INP}$
$f_{CLKINPULOW}$	CLKINPULOW bypass input clock frequency	0.001		600	MHz	Bypass mode: $f_{CLKOUT} = f_{CLKINPULOW} / (M1 + 1)$ if ulowclken = 1 <sup>(4)</sup>
$f_{CLKLDOOUT}$	CLKOUTLDO output clock frequency	20 <sup>(1)(5)</sup>		2500 <sup>(2)(5)</sup>	MHz	$M / (N + 1)] \times F_{INP} \times [1 / M2]$ (in locked condition)
$f_{CLKOUT}$	CLKOUT output clock frequency	20 <sup>(1)(5)</sup>		1450 <sup>(2)(5)</sup>	MHz	$[M / (N + 1)] \times F_{INP} \times [1 / M2]$ (in locked condition)
$f_{CLKDCOLDO}$	Internal oscillator (DCO) output clock frequency	750 <sup>(5)</sup>		1500 <sup>(5)</sup>	MHz	$[M / (N + 1)] \times F_{INP}$ (in locked condition)
		1250 <sup>(5)</sup>		2500 <sup>(5)</sup>	MHz	
$t_j$	CLKOUTLDO period jitter	-2.5%		2.5%		The period jitter at the output clocks is $\pm 2.5\%$ peak to peak
	CLKOUT period jitter					
	CLKDCOLDO period jitter					
$t_{lock}$	Frequency lock time			350 × REFCLKs	μs	
$p_{lock}$	Phase lock time			500 × REFCLKs	μs	
$t_{relock-L}$	Relock time—Frequency lock <sup>(3)</sup> (LP relock time from bypass)			9 + 30 × REFCLKs	μs	
$p_{relock-L}$	Relock time—Phase lock <sup>(3)</sup> (LP relock time from bypass)			9 + 125 × REFCLKs	μs	

(1) The minimum frequency on CLKOUT is assuming  $M2 = 1$ .

For  $M2 > 1$ , the minimum frequency on this clock will further scale down by factor of  $M2$ .

(2) The maximum frequency on CLKOUT is assuming  $M2 = 1$ .

(3) Relock time assumes typical operating conditions, 10 °C maximum temperature drift.

(4) Bypass mode:  $f_{CLKOUT} = F_{INP}$  if ULOWCLKEN = 0. For more information, see the device TRM.

(5) For output clocks, there are two frequency ranges according to the SELFREQDCO setting. For more information, see the device TRM.

#### 5.10.4.4.2 DLL Characteristics

Table 5-32 summarizes the DLL characteristics and assumes testing over recommended operating conditions.

**Table 5-32. DLL Characteristics**

NAME	DESCRIPTION	MIN	TYP	MAX	UNIT
$f_{input}$	Input clock frequency (EMIF_DLL_FCLK)			333	MHz
$t_{lock}$	Lock time			50k	cycles
$t_{relock}$	Relock time (a change of the DLL frequency implies that DLL must relock)			50k	cycles

#### 5.10.5 Recommended Clock and Control Signal Transition Behavior

All clocks and control signals **must** transition between  $V_{IH}$  and  $V_{IL}$  (or between  $V_{IL}$  and  $V_{IH}$ ) in a monotonic manner. Monotonic transitions are more easily ensured with faster switching signals. Slower input transitions are more susceptible to glitches due to noise and special care should be taken for slow input clocks.

## 5.10.6 Peripherals

### 5.10.6.1 Timing Test Conditions

All timing requirements and switching characteristics are valid over the recommended operating conditions unless otherwise specified.

### 5.10.6.2 Virtual and Manual I/O Timing Modes

Some of the timings described in the following sections require the use of Virtual or Manual I/O Timing Modes. [Table 5-33](#) provides a summary of the Virtual and Manual I/O Timing Modes across all device interfaces. The individual interface timing sections found later in this document provide the full description of each applicable Virtual and Manual I/O Timing Mode. Refer to the Pad Configuration section of the Device TRM for the procedure on implementing the Virtual and Manual Timing Modes in a system.

**Table 5-33. Modes Summary**

VIRTUAL OR MANUAL IO MODE NAME	DATASHEET TIMING MODE
<b>VIP</b>	
<a href="#">VIP1_MANUAL1</a>	VIN1A/1B/2A Rise-Edge Capture Mode Timings
<a href="#">VIP1_2B_MANUAL1</a>	VIN2B Rise-Edge Capture Mode Timings
<a href="#">VIP1_MANUAL2</a>	VIN1A/1B/2A Fall-Edge Capture Mode Timings
<a href="#">VIP1_2B_MANUAL2</a>	VIN2B Fall-Edge Capture Mode Timings
<a href="#">VIP2_MANUAL1</a>	VIN3A and VIN3B IOSET1 Rise-Edge Capture Mode Timings
<a href="#">VIP2_4A_MANUAL1</a>	VIN4A IOSET1/2 Rise-Edge Capture Mode Timings
<a href="#">VIP2_4A_IOSET3_MANUAL1</a>	VIN4A IOSET3 Rise-Edge Capture Mode Timings
<a href="#">VIP2_4B_MANUAL1</a>	VIN4B Rise-Edge Capture Mode Timings
<a href="#">VIP2_3B_IOSET2_MANUAL1</a>	VIN3B IOSET2 Rise-Edge Capture Mode Timings
<a href="#">VIP2_3B_IOSET2_MANUAL2</a>	VIN3B IOSET2 Fall-Edge Capture Mode Timings
<a href="#">VIP2_MANUAL2</a>	VIN3A, VIN3B IOSET1 Fall-Edge Capture Mode Timings
<a href="#">VIP2_4A_MANUAL2</a>	VIN4A IOSET1/2 Fall-Edge Capture Mode Timings
<a href="#">VIP2_4A_IOSET3_MANUAL2</a>	VIN4A IOSET3 Fall-Edge Capture Mode Timings
<a href="#">VIP2_4B_MANUAL2</a>	VIN4B Fall-Edge Capture Mode Timings
<b>DPI Video Output</b>	
<a href="#">VOUT1_MANUAL1</a>	DPI1 Video Output Alternate Timings
<a href="#">VOUT1_MANUAL2</a>	DPI1 Video Output Default Timings
<a href="#">VOUT1_MANUAL3</a>	DPI1 Video Output MANUAL3 Timings
<a href="#">VOUT1_MANUAL4</a>	DPI1 Video Output MANUAL4 Timings
<a href="#">VOUT2_IOSET1_MANUAL1</a>	DPI2 Video Output IOSET1 Alternate Timings
<a href="#">VOUT2_IOSET1_MANUAL2</a>	DPI2 Video Output IOSET1 Default Timings
<a href="#">VOUT2_IOSET1_MANUAL3</a>	DPI2 Video Output IOSET1 MANUAL3 Timings
<a href="#">VOUT2_IOSET1_MANUAL4</a>	DPI2 Video Output IOSET1 MANUAL4 Timings
<a href="#">VOUT2_IOSET2_MANUAL1</a>	DPI2 Video Output IOSET2 Alternate Timings
<a href="#">VOUT2_IOSET2_MANUAL2</a>	DPI2 Video Output IOSET2 Default Timings
<a href="#">VOUT2_IOSET2_MANUAL3</a>	DPI2 Video Output IOSET2 MANUAL3 Timings
<a href="#">VOUT2_IOSET2_MANUAL4</a>	DPI2 Video Output IOSET2 MANUAL4 Timings
<a href="#">VOUT3_MANUAL1</a>	DPI3 Video Output Alternate Timings
<a href="#">VOUT3_MANUAL2</a>	DPI3 Video Output Default Timings
<a href="#">VOUT3_MANUAL3</a>	DPI3 Video Output MANUAL3 Timings
<a href="#">VOUT3_MANUAL4</a>	DPI3 Video Output MANUAL4 Timings
<b>GPMC</b>	
No Virtual or Manual IO Timing Mode Required	GPMC Asynchronous Mode Timings and Synchronous Mode - Default Timings

**Table 5-33. Modes Summary (continued)**

VIRTUAL OR MANUAL IO MODE NAME	DATASHEET TIMING MODE
<a href="#">GPMC_VIRTUAL1</a>	GPMC Synchronous Mode - Alternate Timings
<b>McASP</b>	
No Virtual or Manual IO Timing Mode Required	McASP1 Synchronous Transmit Timings
<a href="#">MCASP1_VIRTUAL1_ASYNC_TX</a>	See <a href="#">Table 5-86</a>
<a href="#">MCASP1_VIRTUAL2_SYNC_RX</a>	See <a href="#">Table 5-86</a>
<a href="#">MCASP1_VIRTUAL3_ASYNC_RX</a>	See <a href="#">Table 5-86</a>
No Virtual or Manual IO Timing Mode Required	McASP2 Synchronous Transmit Timings
<a href="#">MCASP2_VIRTUAL1_ASYNC_RX_80M</a>	See <a href="#">Table 5-87</a>
<a href="#">MCASP2_VIRTUAL2_ASYNC_RX</a>	See <a href="#">Table 5-87</a>
<a href="#">MCASP2_VIRTUAL3_ASYNC_TX</a>	See <a href="#">Table 5-87</a>
<a href="#">MCASP2_VIRTUAL4_SYNC_RX</a>	See <a href="#">Table 5-87</a>
<a href="#">MCASP2_VIRTUAL5_SYNC_RX_80M</a>	See <a href="#">Table 5-87</a>
No Virtual or Manual IO Timing Mode Required	McASP3 Synchronous Transmit Timings
<a href="#">MCASP3_VIRTUAL2_SYNC_RX</a>	See <a href="#">Table 5-88</a>
No Virtual or Manual IO Timing Mode Required	McASP4 Synchronous Transmit Timings
<a href="#">MCASP4_VIRTUAL1_SYNC_RX</a>	See <a href="#">Table 5-89</a>
No Virtual or Manual IO Timing Mode Required	McASP5 Synchronous Transmit Timings
<a href="#">MCASP5_VIRTUAL1_SYNC_RX</a>	See <a href="#">Table 5-90</a>
No Virtual or Manual IO Timing Mode Required	McASP6 Synchronous Transmit Timings
<a href="#">MCASP6_VIRTUAL1_SYNC_RX</a>	See <a href="#">Table 5-91</a>
No Virtual or Manual IO Timing Mode Required	McASP7 Synchronous Transmit Timings
<a href="#">MCASP7_VIRTUAL2_SYNC_RX</a>	See <a href="#">Table 5-92</a>
No Virtual or Manual IO Timing Mode Required	McASP8 Synchronous Transmit Timings
<a href="#">MCASP8_VIRTUAL1_SYNC_RX</a>	See <a href="#">Table 5-93</a>
<b>eMMC/SD/SDIO</b>	
No Virtual or Manual IO Timing Mode Required	MMC1 DS (Pad Loopback) and SDR12 (Pad Loopback) Timings
<a href="#">MMC1_VIRTUAL1</a>	MMC1 HS (Internal Loopback and Pad Loopback), SDR12 (Internal Loopback), SDR25 Timings (Internal Loopback and Pad Loopback)
<a href="#">MMC1_VIRTUAL2</a>	SDR50 (Pad Loopback) Timings
<a href="#">MMC1_VIRTUAL5</a>	MMC1 DS (Internal Loopback) Timings
<a href="#">MMC1_VIRTUAL6</a>	MMC1 SDR50 (Internal Loopback) Timings
<a href="#">MMC1_VIRTUAL7</a>	MMC1 DDR50 (Internal Loopback) Timings
<a href="#">MMC1_DDR_MANUAL1</a>	MMC1 DDR50 (Pad Loopback) Timings
<a href="#">MMC1_SDR104_MANUAL1</a>	MMC1 SDR104 Timings
No Virtual or Manual IO Timing Mode Required	MMC2 Standard (Pad Loopback), High Speed (Pad Loopback), and DDR (Pad Loopback) Timings
<a href="#">MMC2_DDR_LB_MANUAL1</a>	MMC2 DDR (Internal Loopback) Timings
<a href="#">MMC2_HS200_MANUAL1</a>	MMC2 HS200 Timings
<a href="#">MMC2_STD_HS_LB_MANUAL1</a>	MMC2 Standard (Internal Loopback), High Speed (Internal Loopback) Timings
<a href="#">MMC3_MANUAL1</a>	MMC3 DS, SDR12, HS, SDR25 Timings
<a href="#">MMC3_MANUAL2</a>	MMC3 SDR50 Timings
<a href="#">MMC4_MANUAL1</a>	MMC4 SDR12, HS, SDR25 Timings
<a href="#">MMC4_DS_MANUAL1</a>	MMC4 DS Timings
<b>QSPI</b>	
No Virtual or Manual IO Timing Mode Required	QSPI Mode 3 Boot Timing Mode
<a href="#">QSPI_MODE3_MANUAL1</a>	QSPI Mode 3 Default Timing Mode
<a href="#">QSPI_MODE0_MANUAL1</a>	QSPI Mode 0 Default Timing Mode
<b>GMAC</b>	



**Table 5-33. Modes Summary (continued)**

VIRTUAL OR MANUAL IO MODE NAME	DATASHEET TIMING MODE
No Virtual or Manual IO Timing Mode Required	GMAC MII0/1 Timings
<a href="#">GMAC_RMII0_MANUAL1</a>	GMAC RMII0 Timings
<a href="#">GMAC_RMII1_MANUAL1</a>	GMAC RMII1 Timings
<a href="#">GMAC_RGMII0_MANUAL1</a>	GMAC RGMII0 Internal Delay Enabled Timings
<a href="#">GMAC_RGMII1_MANUAL1</a>	GMAC RGMII1 Internal Delay Enabled Timings
<b>HDMI, EMIF, Timers, I2C, HDQ/1-Wire, UART, McSPI, USB, SATA, PCIe, DCAN, GPIO, KBD, PWM, JTAG, TPIU, RTC, SDMA, INTC</b>	
No Virtual or Manual IO Timing Mode Required	All Modes
<b>PRU-ICSS</b>	
<a href="#">PR1_PRU0_DIR_OUT_MANUAL</a>	PRU-ICSS1 PRU0 Direct Output Mode Timings
<a href="#">PR1_PRU1_DIR_OUT_MANUAL</a>	PRU-ICSS1 PRU1 Direct Output Mode Timings
<a href="#">PR1_PRU0_DIR_IN_MANUAL</a>	PRU-ICSS1 PRU0 Direct Input Mode Timings
<a href="#">PR1_PRU1_DIR_IN_MANUAL</a>	PRU-ICSS1 PRU1 Direct Input Mode Timings
<a href="#">PR1_PRU0_PAR_CAP_MANUAL</a>	PRU-ICSS1 PRU0 Parallel Capture Mode Timings
<a href="#">PR1_PRU1_PAR_CAP_MANUAL</a>	PRU-ICSS1 PRU1 Parallel Capture Mode Timings
<a href="#">PR2_PRU0_DIR_IN_MANUAL1</a>	PRU-ICSS2 PRU0 IOSET1 Direct Input Mode Timings
<a href="#">PR2_PRU0_DIR_IN_MANUAL2</a>	PRU-ICSS2 PRU0 IOSET2 Direct Input Mode Timings
<a href="#">PR2_PRU0_DIR_OUT_MANUAL1</a>	PRU-ICSS2 PRU0 IOSET1 Direct Output Mode Timings
<a href="#">PR2_PRU0_DIR_OUT_MANUAL2</a>	PRU-ICSS2 PRU0 IOSET2 Direct Output Mode Timings
<a href="#">PR2_PRU1_DIR_IN_MANUAL1</a>	PRU-ICSS2 PRU1 IOSET1 Direct Input Mode Timings
<a href="#">PR2_PRU1_DIR_IN_MANUAL2</a>	PRU-ICSS2 PRU1 IOSET2 Direct Input Mode Timings
<a href="#">PR2_PRU1_DIR_OUT_MANUAL1</a>	PRU-ICSS2 PRU1 IOSET1 Direct Output Mode Timings
<a href="#">PR2_PRU1_DIR_OUT_MANUAL2</a>	PRU-ICSS2 PRU1 IOSET2 Direct Output Mode Timings
<a href="#">PR2_PRU0_PAR_CAP_MANUAL1</a>	PRU-ICSS2 PRU0 IOSET1 Parallel Capture Mode Timings
<a href="#">PR2_PRU0_PAR_CAP_MANUAL2</a>	PRU-ICSS2 PRU0 IOSET2 Parallel Capture Mode Timings
<a href="#">PR2_PRU1_PAR_CAP_MANUAL1</a>	PRU-ICSS2 PRU1 IOSET1 Parallel Capture Mode Timings
<a href="#">PR2_PRU1_PAR_CAP_MANUAL2</a>	PRU-ICSS2 PRU1 IOSET2 Parallel Capture Mode Timings

### 5.10.6.3 VIP

The Device includes 2 Video Input Ports (VIP).

Table 5-34, Figure 5-21 and Figure 5-22 present timings and switching characteristics of the VIPs.

**CAUTION**

The IO timings provided in this section are applicable for all combinations of signals for vin1. However, the timings are only valid for vin2, vin3, and vin4 if signals within a single IOSET are used. The IOSETs are defined in the Table 5-35, Table 5-36 and Table 5-37.

**Table 5-34. Timing Requirements for VIP (3)(4)(5)**

NO.	PARAMETER	DESCRIPTION	MODE	MIN	MAX	UNIT
V1	$t_c(\text{CLK})$	Cycle time, vinx_clki (3) (5)		6.06		ns
V2	$t_w(\text{CLKH})$	Pulse duration, vinx_clki high (3) (5)		0.45P (2)		ns
V3	$t_w(\text{CLKL})$	Pulse duration, vinx_clki low (3) (5)		0.45P (2)		ns
V4	$t_{su}(\text{CTL/DATA-CLK})$	Input setup time, Control (vinx_dei, vinx_vsynci, vinx_fldi, vinx_hsynci) and Data (vinx_dn) valid to vinx_clki transition (3) (4) (5)	vin1x, vin2x	2.93		ns
			vin3x, vin4x	3.11		ns
V5	$t_h(\text{CLK-CTL/DATA})$	Input hold time, Control (vinx_dei, vinx_vsynci, vinx_fldi, vinx_hsynci) and Data (vinx_dn) valid from vinx_clki transition (3) (4) (5)		-0.05		ns

- (1) For maximum frequency of 165 MHz.
- (2) P = vinx\_clki period.
- (3) x in vinx = 1a, 1b, 2a, 2b, 3a, 3b, 4a, 4b.
- (4) n in dn = 0 to 7 when x = 1b, 2b, 3b and 4b;  
n = 0 to 23 when x = 1a, 2a, 3a and 4a;
- (5) i in clki, dei, vsynci, hsynci and fldi = 0 or 1.

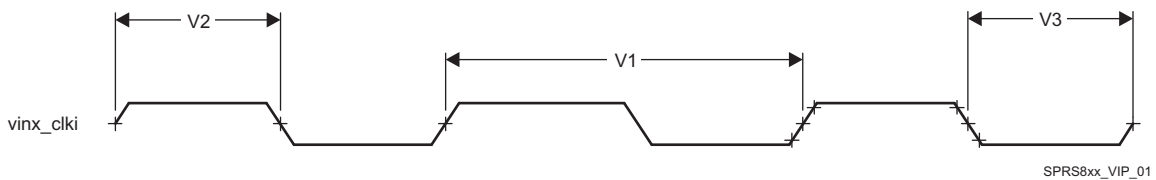

**Figure 5-21. Video Input Ports Clock Signal**

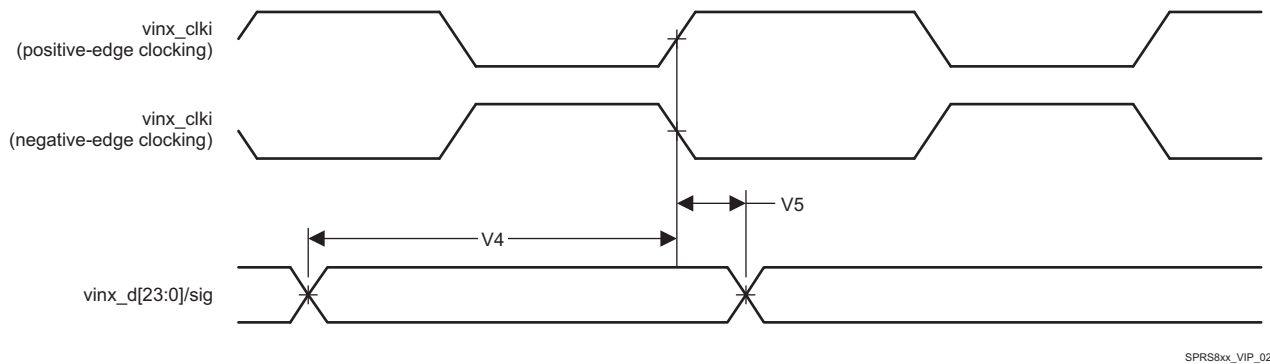

**Figure 5-22. Video Input Ports Timings**

In [Table 5-35](#), [Table 5-36](#) and [Table 5-37](#) are presented the specific groupings of signals (IOSET) for use with vin2, vin3, and vin4.

**Table 5-35. VIN2 IOSETs**

Signals	IOSET1		IOSET2		IOSET3	
	BALL	MUX	BALL	MUX	BALL	MUX
<b>vin2a</b>						
vin2a_d0	F2	0	F2	0	U4	4
vin2a_d1	F3	0	F3	0	V2	4
vin2a_d2	D1	0	D1	0	Y1	4
vin2a_d3	E2	0	E2	0	W9	4
vin2a_d4	D2	0	D2	0	V9	4
vin2a_d5	F4	0	F4	0	U5	4
vin2a_d6	C1	0	C1	0	V5	4
vin2a_d7	E4	0	E4	0	V4	4
vin2a_d8	F5	0	F5	0	V3	4
vin2a_d9	E6	0	E6	0	Y2	4
vin2a_d10	D3	0	D3	0	U6	4
vin2a_d11	F6	0	F6	0	U3	4
vin2a_d12	D5	0	D5	0	-	-
vin2a_d13	C2	0	C2	0	-	-
vin2a_d14	C3	0	C3	0	-	-
vin2a_d15	C4	0	C4	0	-	-
vin2a_d16	B2	0	B2	0	-	-
vin2a_d17	D6	0	D6	0	-	-
vin2a_d18	C5	0	C5	0	-	-
vin2a_d19	A3	0	A3	0	-	-
vin2a_d20	B3	0	B3	0	-	-
vin2a_d21	B4	0	B4	0	-	-
vin2a_d22	B5	0	B5	0	-	-
vin2a_d23	A4	0	A4	0	-	-
vin2a_hsync0	G1	0	G1	0	U7	4
vin2a_vsync0	G6	0	G6	0	V6	4
vin2a_de0	G2	0	-	-	V7	4
vin2a_fld0	H7	0	G2	1	W2	4
vin2a_clk0	E1	0	E1	0	V1	4
<b>vin2b</b>						
vin2b_clk1	H7	2	H7	2	AB5	4
vin2b_de1	-	-	G2	3	AB8	4
vin2b_fld1	G2	2	-	-	-	-
vin2b_d0	A4	2	A4	2	AD6	4
vin2b_d1	B5	2	B5	2	AC8	4
vin2b_d2	B4	2	B4	2	AC3	4
vin2b_d3	B3	2	B3	2	AC9	4
vin2b_d4	A3	2	A3	2	AC6	4
vin2b_d5	C5	2	C5	2	AC7	4
vin2b_d6	D6	2	D6	2	AC4	4
vin2b_d7	B2	2	B2	2	AD4	4
vin2b_hsync1	G1	3	G1	3	AC5	4

Table 5-35. VIN2 IOSETs (continued)

Signals	IOSET1		IOSET2		IOSET3	
	BALL	MUX	BALL	MUX	BALL	MUX
vin2b_vsync1	G6	3	G6	3	AB4	4

Table 5-36. VIN3 IOSETs

Signals	IOSET1		IOSET2		IOSET3		IOSET4	
	BALL	MUX	BALL	MUX	BALL	MUX	BALL	MUX
<b>vin3a</b>								
vin3a_d0	M6	2	AF1	6	AF1	6	B7	4
vin3a_d1	M2	2	AE3	6	AE3	6	B8	4
vin3a_d2	L5	2	AE5	6	AE5	6	A7	4
vin3a_d3	M1	2	AE1	6	AE1	6	A8	4
vin3a_d4	L6	2	AE2	6	AE2	6	C9	4
vin3a_d5	L4	2	AE6	6	AE6	6	A9	4
vin3a_d6	L3	2	AD2	6	AD2	6	B9	4
vin3a_d7	L2	2	AD3	6	AD3	6	A10	4
vin3a_d8	L1	2	B2	6	B2	6	E8	4
vin3a_d9	K2	2	D6	6	D6	6	D9	4
vin3a_d10	J1	2	C5	6	C5	6	D7	4
vin3a_d11	J2	2	A3	6	A3	6	D8	4
vin3a_d12	H1	2	B3	6	-	-	A5	4
vin3a_d13	J3	2	B4	6	-	-	C6	4
vin3a_d14	H2	2	B5	6	-	-	C8	4
vin3a_d15	H3	2	A4	6	-	-	C7	4
vin3a_d16	R6	2	-	-	-	-	F11	4
vin3a_d17	T9	2	-	-	-	-	G10	4
vin3a_d18	T6	2	-	-	-	-	F10	4
vin3a_d19	T7	2	-	-	-	-	G11	4
vin3a_d20	P6	2	-	-	-	-	E9	4
vin3a_d21	R9	2	-	-	-	-	F9	4
vin3a_d22	R5	2	-	-	-	-	F8	4
vin3a_d23	P5	2	-	-	-	-	E7	4
vin3a_hsync0	N7	2	N7	2	B5	5	C11	4
vin3a_vsync0	R4	2	R4	2	A4	5	E11	4
vin3a_de0	N9	2	N9	2	B3	5	B10	4
vin3a_fld0	P9	2	P9	2	B4	5	D11	4
vin3a_clk0	P1	2	AH7	6	AH7	6	B11	4
<b>vin3b</b>								
vin3b_clk1	P7	6	M4	4	-	-	-	-
vin3b_de1	N6	6	N6	6	-	-	-	-
vin3b_fld1	M4	6	-	-	-	-	-	-
vin3b_d0	K7	6	K7	6	-	-	-	-
vin3b_d1	M7	6	M7	6	-	-	-	-
vin3b_d2	J5	6	J5	6	-	-	-	-
vin3b_d3	K6	6	K6	6	-	-	-	-
vin3b_d4	J7	6	J7	6	-	-	-	-
vin3b_d5	J4	6	J4	6	-	-	-	-
vin3b_d6	J6	6	J6	6	-	-	-	-

**Table 5-36. VIN3 IOSETs (continued)**

Signals	IOSET1		IOSET2		IOSET3		IOSET4	
	BALL	MUX	BALL	MUX	BALL	MUX	BALL	MUX
vin3b_d7	H4	6	H4	6	-	-	-	-
vin3b_hsync1	H5	6	H5	6	-	-	-	-
vin3b_vsync1	H6	6	H6	6	-	-	-	-

**Table 5-37. VIN4 IOSETs**

Signals	IOSET1		IOSET2		IOSET3	
	BALL	MUX	BALL	MUX	BALL	MUX
<b>vin4a</b>						
vin4a_d0	R6	4	B7	3	B14	8
vin4a_d1	T9	4	B8	3	J14	8
vin4a_d2	T6	4	A7	3	G13	8
vin4a_d3	T7	4	A8	3	J11	8
vin4a_d4	P6	4	C9	3	E12	8
vin4a_d5	R9	4	A9	3	F13	8
vin4a_d6	R5	4	B9	3	C12	8
vin4a_d7	P5	4	A10	3	D12	8
vin4a_d8	U2	4	E8	3	E15	8
vin4a_d9	U1	4	D9	3	A20	8
vin4a_d10	P3	4	D7	3	B15	8
vin4a_d11	R2	4	D8	3	A15	8
vin4a_d12	K7	4	A5	3	D15	8
vin4a_d13	M7	4	C6	3	B16	8
vin4a_d14	J5	4	C8	3	B17	8
vin4a_d15	K6	4	C7	3	A17	8
vin4a_d16	-	-	F11	3	C18	8
vin4a_d17	-	-	G10	3	A21	8
vin4a_d18	-	-	F10	3	G16	8
vin4a_d19	-	-	G11	3	D17	8
vin4a_d20	-	-	E9	3	AA3	8
vin4a_d21	-	-	F9	3	AB9	8
vin4a_d22	-	-	F8	3	AB3	8
vin4a_d23	-	-	E7	3	AA4	8
vin4a_hsync0	R3/ P7	4 / 4	C11	3	E21	8
vin4a_vsync0	T2/ N1	4 / 4	E11	3	F20	8
vin4a_de0	H6/ P7	4 / 5	B10	3	C23	8
vin4a_fld0	P9/ J7	4 / 4	D11	3	F21	8
vin4a_clk0	P4	4	B11	3	B26	8
<b>vin4b</b>						
vin4b_clk1	N9	6	V1	5	-	-
vin4b_de1	P9	6	V7	5	-	-
vin4b_fld1	P4	6	W2	5	-	-
vin4b_d0	R6	6	U4	5	-	-
vin4b_d1	T9	6	V2	5	-	-
vin4b_d2	T6	6	Y1	5	-	-
vin4b_d3	T7	6	W9	5	-	-
vin4b_d4	P6	6	V9	5	-	-

**Table 5-37. VIN4 IOSETs (continued)**

Signals	IOSET1		IOSET2		IOSET3	
	BALL	MUX	BALL	MUX	BALL	MUX
vin4b_d5	R9	6	U5	5	-	-
vin4b_d6	R5	6	V5	5	-	-
vin4b_d7	P5	6	V4	5	-	-
vin4b_hsync1	N7	6	U7	5	-	-
vin4b_vsync1	R4	6	V6	5	-	-

**NOTE**

To configure the desired manual IO timing mode the user must follow the steps described in *Manual IO Timing Modes* section in the device TRM.

The associated registers to configure are listed in the **CFG REGISTER** column. For more information, see *Control Module* chapter in the device TRM.

Manual IO timings modes must be used to ensure some IO timings for VIP1. See [Table 5-33](#), *Modes Summary* for a list of IO timings requiring the use of manual IO timings modes. See [Table 5-38](#), *Manual Functions Mapping for VIP1* for a definition of the manual modes.

[Table 5-38](#) lists the A\_DELAY and G\_DELAY values needed to calculate the correct values to be set in the CFG\_x registers.

**Table 5-38. Manual Functions Mapping for VIP1**

BALL	BALL NAME	VIP1_MANUAL1		VIP1_MANUAL2		CFG REGISTER	MUXMODE				
		A_DELAY (ps)	G_DELAY (ps)	A_DELAY (ps)	G_DELAY (ps)		0	1	2	3	4
U3	RMII_MHZ_50_CLK	1973	184	2257	0	CFG_RMII_MHZ_50_CLK_IN	-	-	-	-	vin2a_d11
N6	gpmc_ben0	2133	486	2582	77	CFG_GPMC_BEN0_IN	-	-	-	vin1b_hsync1	-
M4	gpmc_ben1	2034	577	2545	109	CFG_GPMC_BEN1_IN	-	-	-	vin1b_de1	-
U4	mdio_d	1897	35	1999	0	CFG_MDIO_D_IN	-	-	-	-	vin2a_d0
V1	mdio_mclk	0	0	0	0	CFG_MDIO_MCLK_IN	-	-	-	-	vin2a_clk0
U5	rgmii0_rxc	1945	97	2072	0	CFG_RGMII0_RXC_IN	-	-	-	-	vin2a_d5
V5	rgmii0_rxctl	1939	440	2326	93	CFG_RGMII0_RXCTL_IN	-	-	-	-	vin2a_d6
W2	rgmii0_rxd0	1990	141	2147	0	CFG_RGMII0_RXD0_IN	-	-	-	-	vin2a_fld0
Y2	rgmii0_rxd1	1928	527	2298	246	CFG_RGMII0_RXD1_IN	-	-	-	-	vin2a_d9
V3	rgmii0_rxd2	1901	425	2280	134	CFG_RGMII0_RXD2_IN	-	-	-	-	vin2a_d8
V4	rgmii0_rxd3	1972	637	2331	362	CFG_RGMII0_RXD3_IN	-	-	-	-	vin2a_d7
W9	rgmii0_txc	1933	382	2347	28	CFG_RGMII0_TXC_IN	-	-	-	-	vin2a_d3
V9	rgmii0_txctl	2019	479	2372	217	CFG_RGMII0_TXCTL_IN	-	-	-	-	vin2a_d4
U6	rgmii0_txd0	1934	203	2205	0	CFG_RGMII0_TXD0_IN	-	-	-	-	vin2a_d10
V6	rgmii0_txd1	2015	604	2360	362	CFG_RGMII0_TXD1_IN	-	-	-	-	vin2a_vsync0
U7	rgmii0_txd2	1839	496	2249	158	CFG_RGMII0_TXD2_IN	-	-	-	-	vin2a_hsync0
V7	rgmii0_txd3	2087	423	2426	108	CFG_RGMII0_TXD3_IN	-	-	-	-	vin2a_de0
V2	uart3_rxd	1578	0	1530	0	CFG_UART3_RXD_IN	-	-	-	-	vin2a_d1
Y1	uart3_txd	1869	99	1967	0	CFG_UART3_TXD_IN	-	-	-	-	vin2a_d2
AG8	vin1a_clk0	0	0	0	0	CFG_VIN1A_CLK0_IN	vin1a_clk0	-	-	-	-
AE8	vin1a_d0	2051	708	2439	275	CFG_VIN1A_D0_IN	vin1a_d0	-	-	-	-
AD8	vin1a_d1	1931	812	2337	447	CFG_VIN1A_D1_IN	vin1a_d1	-	-	-	-
AG3	vin1a_d10	2049	804	2420	448	CFG_VIN1A_D10_IN	vin1a_d10	vin1b_d5	-	-	-
AG5	vin1a_d11	1921	766	2331	438	CFG_VIN1A_D11_IN	vin1a_d11	vin1b_d4	-	-	-
AF2	vin1a_d12	2078	1220	2397	915	CFG_VIN1A_D12_IN	vin1a_d12	vin1b_d3	-	-	-
AF6	vin1a_d13	1986	1138	2366	788	CFG_VIN1A_D13_IN	vin1a_d13	vin1b_d2	-	-	-
AF3	vin1a_d14	2077	1242	2403	947	CFG_VIN1A_D14_IN	vin1a_d14	vin1b_d1	-	-	-
AF4	vin1a_d15	2070	1581	2337	1407	CFG_VIN1A_D15_IN	vin1a_d15	vin1b_d0	-	-	-
AF1	vin1a_d16	2008	1432	2321	1202	CFG_VIN1A_D16_IN	vin1a_d16	vin1b_d7	-	-	-
AE3	vin1a_d17	2077	1571	2370	1351	CFG_VIN1A_D17_IN	vin1a_d17	vin1b_d6	-	-	-
AE5	vin1a_d18	2075	1527	2357	1292	CFG_VIN1A_D18_IN	vin1a_d18	vin1b_d5	-	-	-

**Table 5-38. Manual Functions Mapping for VIP1 (continued)**

BAL L	BALL NAME	VIP1_MANUAL1		VIP1_MANUAL2		CFG REGISTER	MUXMODE				
		A_DELAY (ps)	G_DELAY (ps)	A_DELAY (ps)	G_DELAY (ps)		0	1	2	3	4
AE1	vin1a_d19	2055	1636	2358	1422	CFG_VIN1A_D19_IN	vin1a_d19	vin1b_d4	-	-	-
AG7	vin1a_d2	1871	1037	2301	620	CFG_VIN1A_D2_IN	vin1a_d2	-	-	-	
AE2	vin1a_d20	2046	1452	2351	1163	CFG_VIN1A_D20_IN	vin1a_d20	vin1b_d3	-	-	-
AE6	vin1a_d21	2135	1292	2405	1024	CFG_VIN1A_D21_IN	vin1a_d21	vin1b_d2	-	-	-
AD2	vin1a_d22	2034	1430	2348	1206	CFG_VIN1A_D22_IN	vin1a_d22	vin1b_d1	-	-	-
AD3	vin1a_d23	2191	813	2502	447	CFG_VIN1A_D23_IN	vin1a_d23	vin1b_d0	-	-	-
AH6	vin1a_d3	1938	984	2299	658	CFG_VIN1A_D3_IN	vin1a_d3	-	-	-	-
AH3	vin1a_d4	2034	597	2424	178	CFG_VIN1A_D4_IN	vin1a_d4	-	-	-	-
AH5	vin1a_d5	1961	927	2359	554	CFG_VIN1A_D5_IN	vin1a_d5	-	-	-	-
AG6	vin1a_d6	1909	930	2323	549	CFG_VIN1A_D6_IN	vin1a_d6	-	-	-	-
AH4	vin1a_d7	1999	901	2383	557	CFG_VIN1A_D7_IN	vin1a_d7	-	-	-	-
AG4	vin1a_d8	2040	856	2426	448	CFG_VIN1A_D8_IN	vin1a_d8	vin1b_d7	-	-	-
AG2	vin1a_d9	2133	799	2472	388	CFG_VIN1A_D9_IN	vin1a_d9	vin1b_d6	-	-	-
AD9	vin1a_de0	1842	861	2258	352	CFG_VIN1A_DE0_IN	vin1a_de0	vin1b_hsync1	-	-	-
AF9	vin1a_fld0	1968	1029	2347	622	CFG_VIN1A_FLD0_IN	vin1a_fld0	vin1b_vsync1	-	-	-
AE9	vin1a_hsync0	1871	1264	2257	881	CFG_VIN1A_HSYNC0_IN	vin1a_hsync0	vin1b_fld1	-	-	-
AF8	vin1a_vsync0	1798	1000	2243	649	CFG_VIN1A_VSYNC0_IN	vin1a_vsync0	vin1b_de1	-	-	-
AH7	vin1b_clk1	160	0	227	0	CFG_VIN1B_CLK1_IN	vin1b_clk1	-	-	-	-
E1	vin2a_clk0	0	0	0	0	CFG_VIN2A_CLK0_IN	vin2a_clk0	-	-	-	-
F2	vin2a_d0	1920	227	2180	0	CFG_VIN2A_D0_IN	vin2a_d0	-	-	-	-
F3	vin2a_d1	1957	476	2326	309	CFG_VIN2A_D1_IN	vin2a_d1	-	-	-	-
D3	vin2a_d10	1865	337	2297	110	CFG_VIN2A_D10_IN	vin2a_d10	-	-	-	-
F6	vin2a_d11	1753	19	1938	0	CFG_VIN2A_D11_IN	vin2a_d11	-	-	-	-
D5	vin2a_d12	1654	487	2135	182	CFG_VIN2A_D12_IN	vin2a_d12	-	-	-	-
C2	vin2a_d13	1927	132	2134	0	CFG_VIN2A_D13_IN	vin2a_d13	-	-	-	-
C3	vin2a_d14	1715	0	1753	0	CFG_VIN2A_D14_IN	vin2a_d14	-	-	-	-
C4	vin2a_d15	1745	381	2222	63	CFG_VIN2A_D15_IN	vin2a_d15	-	-	-	-
B2	vin2a_d16	1670	319	2137	58	CFG_VIN2A_D16_IN	vin2a_d16	-	vin2b_d7	-	-
D6	vin2a_d17	1709	409	2192	79	CFG_VIN2A_D17_IN	vin2a_d17	-	vin2b_d6	-	-
C5	vin2a_d18	2033	334	2378	21	CFG_VIN2A_D18_IN	vin2a_d18	-	vin2b_d5	-	-
A3	vin2a_d19	1957	193	2207	0	CFG_VIN2A_D19_IN	vin2a_d19	-	vin2b_d4	-	-
D1	vin2a_d2	1912	5	2057	0	CFG_VIN2A_D2_IN	vin2a_d2	-	-	-	-



**Table 5-38. Manual Functions Mapping for VIP1 (continued)**

BALL	BALL NAME	VIP1_MANUAL1		VIP1_MANUAL2		CFG REGISTER	MUXMODE				
		A_DELAY (ps)	G_DELAY (ps)	A_DELAY (ps)	G_DELAY (ps)		0	1	2	3	4
B3	vin2a_d20	1938	619	2325	388	CFG_VIN2A_D20_IN	vin2a_d20	-	vin2b_d3	-	-
B4	vin2a_d21	1899	546	2320	221	CFG_VIN2A_D21_IN	vin2a_d21	-	vin2b_d2	-	-
B5	vin2a_d22	1800	272	2219	30	CFG_VIN2A_D22_IN	vin2a_d22	-	vin2b_d1	-	-
A4	vin2a_d23	1807	476	2225	200	CFG_VIN2A_D23_IN	vin2a_d23	-	vin2b_d0	-	-
E2	vin2a_d3	2095	421	2440	257	CFG_VIN2A_D3_IN	vin2a_d3	-	-	-	-
D2	vin2a_d4	2008	0	2142	0	CFG_VIN2A_D4_IN	vin2a_d4	-	-	-	-
F4	vin2a_d5	2137	406	2455	252	CFG_VIN2A_D5_IN	vin2a_d5	-	-	-	-
C1	vin2a_d6	1717	0	1883	0	CFG_VIN2A_D6_IN	vin2a_d6	-	-	-	-
E4	vin2a_d7	1850	171	2229	0	CFG_VIN2A_D7_IN	vin2a_d7	-	-	-	-
F5	vin2a_d8	1841	340	2250	151	CFG_VIN2A_D8_IN	vin2a_d8	-	-	-	-
E6	vin2a_d9	1836	289	2279	27	CFG_VIN2A_D9_IN	vin2a_d9	-	-	-	-
G2	vin2a_de0	1772	316	2202	0	CFG_VIN2A_DE0_IN	vin2a_de0	vin2a_fld0	vin2b_fld1	vin2b_de1	-
H7	vin2a_fld0	2117	507	2453	357	CFG_VIN2A_FLD0_IN	vin2a_fld0	-	vin2b_clk1	-	-
G1	vin2a_hsync0	1969	231	2233	0	CFG_VIN2A_HSYNC0_IN	vin2a_hsync0	-	-	vin2b_hsync1	-
G6	vin2a_vsync0	1793	110	1936	0	CFG_VIN2A_VSYNC0_IN	vin2a_vsync0	-	-	vin2b_vsync1	-

Manual IO Timings Modes must be used to ensure some IO timings for VIP1. See [Table 5-33, Modes Summary](#) for a list of IO timings requiring the use of Manual IO Timings Modes. See [Table 5-39, Manual Functions Mapping for VIP1 2B](#) for a definition of the Manual modes.

[Table 5-39](#) lists the A\_DELAY and G\_DELAY values needed to calculate the correct values to be set in the CFG\_x registers.

**Table 5-39. Manual Functions Mapping for VIP1 2B**

BALL	BALL NAME	VIP1_2B_MANUAL1		VIP1_2B_MANUAL2		CFG REGISTER	MUXMODE		
		A_DELAY (ps)	G_DELAY (ps)	A_DELAY (ps)	G_DELAY (ps)		2	3	4
AC5	gpio6_10	2207	0	2288	0	CFG_GPIO6_10_IN	-	-	vin2b_hsync1
AB4	gpio6_11	2183	225	2486	77	CFG_GPIO6_11_IN	-	-	vin2b_vsync1
AD4	mmc3_clk	2262	114	2452	0	CFG_MMC3_CLK_IN	-	-	vin2b_d7
AC4	mmc3_cmd	2228	108	2425	0	CFG_MMC3_CMD_IN	-	-	vin2b_d6
AC7	mmc3_dat0	2137	170	2463	0	CFG_MMC3_DAT0_IN	-	-	vin2b_d5
AC6	mmc3_dat1	2116	154	2393	0	CFG_MMC3_DAT1_IN	-	-	vin2b_d4
AC9	mmc3_dat2	1891	0	1945	0	CFG_MMC3_DAT2_IN	-	-	vin2b_d3
AC3	mmc3_dat3	2202	197	2516	22	CFG_MMC3_DAT3_IN	-	-	vin2b_d2
AC8	mmc3_dat4	1966	0	1991	0	CFG_MMC3_DAT4_IN	-	-	vin2b_d1

**Table 5-39. Manual Functions Mapping for VIP1 2B (continued)**

BALL	BALL NAME	VIP1_2B_MANUAL1		VIP1_2B_MANUAL2		CFG REGISTER	MUXMODE		
		A_DELAY (ps)	G_DELAY (ps)	A_DELAY (ps)	G_DELAY (ps)		2	3	4
AD6	mmc3_dat5	2163	15	2361	0	CFG_MMC3_DAT5_IN	-	-	vin2b_d0
AB8	mmc3_dat6	2162	51	2319	0	CFG_MMC3_DAT6_IN	-	-	vin2b_de1
AB5	mmc3_dat7	0	0	0	0	CFG_MMC3_DAT7_IN	-	-	vin2b_clk1
B2	vin2a_d16	1175	0	1413	0	CFG_VIN2A_D16_IN	vin2b_d7	-	-
D6	vin2a_d17	1323	0	1522	0	CFG_VIN2A_D17_IN	vin2b_d6	-	-
C5	vin2a_d18	1513	0	1580	0	CFG_VIN2A_D18_IN	vin2b_d5	-	-
A3	vin2a_d19	1278	0	1396	0	CFG_VIN2A_D19_IN	vin2b_d4	-	-
B3	vin2a_d20	1676	0	1895	0	CFG_VIN2A_D20_IN	vin2b_d3	-	-
B4	vin2a_d21	1610	0	1774	0	CFG_VIN2A_D21_IN	vin2b_d2	-	-
B5	vin2a_d22	1250	0	1497	0	CFG_VIN2A_D22_IN	vin2b_d1	-	-
A4	vin2a_d23	1434	0	1643	0	CFG_VIN2A_D23_IN	vin2b_d0	-	-
G2	vin2a_de0	1539	147	1793	0	CFG_VIN2A_DE0_IN	vin2b fld1	vin2b_de1	-
H7	vin2a_fld0	0	0	0	0	CFG_VIN2A_FLD0_IN	vin2b_clk1	-	-
G1	vin2a_hsync0	1475	0	1542	0	CFG_VIN2A_HSYNC0_IN	-	vin2b_hsync1	-
G6	vin2a_vsync0	1163	0	1218	0	CFG_VIN2A_VSYNC0_IN	-	vin2b_vsync1	-

(1) The CFG\_MMC3\_CLK\_IN register should remain at its Default value, which is programmed automatically by hardware during the recalibration process.

Manual IO Timings Modes must be used to ensure some IO timings for VIP2. See [Table 5-33, Modes Summary](#) for a list of IO timings requiring the use of Manual IO Timings Modes. See [Table 5-40, Manual Functions Mapping for VIP2](#) for a definition of the Manual modes.

[Table 5-40](#) lists the A\_DELAY and G\_DELAY values needed to calculate the correct values to be set in the CFG\_x registers.

**Table 5-40. Manual Functions Mapping for VIP2**

BALL	BALL NAME	VIP2_MANUAL 1		VIP2_MANUAL2		CFG REGISTER	MUXMODE				
		A_DELAY (ps)	G_DELAY (ps)	A_DELAY (ps)	G_DELAY (ps)		2	3	4	5	6
R6	gpmc_a0	2558	565	2920	260	CFG_GPMC_A0_IN	vin3a_d16	-	vin4a_d0	-	-
T9	gpmc_a1	2421	648	2782	349	CFG_GPMC_A1_IN	vin3a_d17	-	vin4a_d1	-	-
N9	gpmc_a10	2378	477	2765	0	CFG_GPMC_A10_IN	vin3a_de0	-	-	-	-
P9	gpmc_a11	2409	579	2783	295	CFG_GPMC_A11_IN	vin3a_fld0	-	vin4a_fld0	-	-
K7	gpmc_a19	1887	0	1735	0	CFG_GPMC_A19_IN	-	-	vin4a_d12	-	vin3b_d0
T6	gpmc_a2	2624	893	2882	682	CFG_GPMC_A2_IN	vin3a_d18	-	vin4a_d2	-	-
M7	gpmc_a20	1670	0	1508	0	CFG_GPMC_A20_IN	-	-	vin4a_d13	-	vin3b_d1
J5	gpmc_a21	1925	0	1763	0	CFG_GPMC_A21_IN	-	-	vin4a_d14	-	vin3b_d2

**Table 5-40. Manual Functions Mapping for VIP2 (continued)**

BALL	BALL NAME	VIP2_MANUAL 1		VIP2_MANUAL2		CFG REGISTER	MUXMODE				
		A_DELAY (ps)	G_DELAY (ps)	A_DELAY (ps)	G_DELAY (ps)		2	3	4	5	6
K6	gpmc_a22	1777	0	1631	0	CFG_GPMC_A22_IN	-	-	vin4a_d15	-	vin3b_d3
J7	gpmc_a23	1716	0	1717	0	CFG_GPMC_A23_IN	-	-	vin4a_fld0	-	vin3b_d4
J4	gpmc_a24	1758	111	1756	0	CFG_GPMC_A24_IN	-	-	-	-	vin3b_d5
J6	gpmc_a25	1805	0	1667	0	CFG_GPMC_A25_IN	-	-	-	-	vin3b_d6
H4	gpmc_a26	1800	54	1699	0	CFG_GPMC_A26_IN	-	-	-	-	vin3b_d7
H5	gpmc_a27	1661	0	1540	0	CFG_GPMC_A27_IN	-	-	-	-	vin3b_hsync1
T7	gpmc_a3	2589	902	2855	715	CFG_GPMC_A3_IN	vin3a_d19	-	vin4a_d3	-	-
P6	gpmc_a4	2616	808	2874	597	CFG_GPMC_A4_IN	vin3a_d20	-	vin4a_d4	-	-
R9	gpmc_a5	2514	733	2842	491	CFG_GPMC_A5_IN	vin3a_d21	-	vin4a_d5	-	-
R5	gpmc_a6	2511	417	2837	146	CFG_GPMC_A6_IN	vin3a_d22	-	vin4a_d6	-	-
P5	gpmc_a7	2752	618	3035	325	CFG_GPMC_A7_IN	vin3a_d23	-	vin4a_d7	-	-
N7	gpmc_a8	2457	603	2812	203	CFG_GPMC_A8_IN	vin3a_hsync0	-	-	-	-
R4	gpmc_a9	2536	749	2857	409	CFG_GPMC_A9_IN	vin3a_vsync0	-	-	-	-
M6	gpmc_ad0	2139	232	2444	0	CFG_GPMC_AD0_IN	vin3a_d0	-	-	-	-
M2	gpmc_ad1	2429	212	2711	0	CFG_GPMC_AD1_IN	vin3a_d1	-	-	-	-
J1	gpmc_ad10	2294	337	2703	16	CFG_GPMC_AD10_IN	vin3a_d10	-	-	-	-
J2	gpmc_ad11	2184	327	2600	0	CFG_GPMC_AD11_IN	vin3a_d11	-	-	-	-
H1	gpmc_ad12	2222	182	2471	0	CFG_GPMC_AD12_IN	vin3a_d12	-	-	-	-
J3	gpmc_ad13	2179	152	2421	0	CFG_GPMC_AD13_IN	vin3a_d13	-	-	-	-
H2	gpmc_ad14	2166	16	2263	0	CFG_GPMC_AD14_IN	vin3a_d14	-	-	-	-
H3	gpmc_ad15	2191	254	2535	0	CFG_GPMC_AD15_IN	vin3a_d15	-	-	-	-
L5	gpmc_ad2	2412	314	2776	41	CFG_GPMC_AD2_IN	vin3a_d2	-	-	-	-
M1	gpmc_ad3	2249	227	2503	0	CFG_GPMC_AD3_IN	vin3a_d3	-	-	-	-
L6	gpmc_ad4	2317	256	2613	0	CFG_GPMC_AD4_IN	vin3a_d4	-	-	-	-
L4	gpmc_ad5	2254	108	2441	0	CFG_GPMC_AD5_IN	vin3a_d5	-	-	-	-
L3	gpmc_ad6	2164	279	2533	0	CFG_GPMC_AD6_IN	vin3a_d6	-	-	-	-
L2	gpmc_ad7	2278	230	2597	0	CFG_GPMC_AD7_IN	vin3a_d7	-	-	-	-
L1	gpmc_ad8	2246	449	2701	84	CFG_GPMC_AD8_IN	vin3a_d8	-	-	-	-
K2	gpmc_ad9	2222	298	2607	0	CFG_GPMC_AD9_IN	vin3a_d9	-	-	-	-
N6	gpmc_ben0	1767	0	1686	0	CFG_GPMC_BEN0_IN	-	-	-	-	vin3b_de1
M4	gpmc_ben1	1838	0	1766	0	CFG_GPMC_BEN1_IN	-	-	vin3b_clk1	-	vin3b_fld1
P7	gpmc_clk	0	0	0	0	CFG_GPMC_CLK_IN	-	-	vin4a_hsync0	vin4a_de0	vin3b_clk1

**Table 5-40. Manual Functions Mapping for VIP2 (continued)**

BAL L	BALL NAME	VIP2_MANUAL 1		VIP2_MANUAL2		CFG REGISTER	MUXMODE				
		A_DELAY (ps)	G_DELAY (ps)	A_DELAY (ps)	G_DELAY (ps)		2	3	4	5	6
H6	gpmc_cs1	1611	0	1450	0	CFG_GPMC_CS1_IN	-	-	vin4a_de0	-	vin3b_vsync1
P1	gpmc_cs3	0	0	0	0	CFG_GPMC_CS3_IN	vin3a_clk0	-	-	-	-
AF1	vin1a_d16	2152	1311	2633	790	CFG_VIN1A_D16_IN	-	-	-	-	vin3a_d0
AE3	vin1a_d17	2211	1381	2690	849	CFG_VIN1A_D17_IN	-	-	-	-	vin3a_d1
AE5	vin1a_d18	2220	1393	2669	879	CFG_VIN1A_D18_IN	-	-	-	-	vin3a_d2
AE1	vin1a_d19	2186	1418	2680	870	CFG_VIN1A_D19_IN	-	-	-	-	vin3a_d3
AE2	vin1a_d20	2183	1292	2666	707	CFG_VIN1A_D20_IN	-	-	-	-	vin3a_d4
AE6	vin1a_d21	2280	1155	2721	601	CFG_VIN1A_D21_IN	-	-	-	-	vin3a_d5
AD2	vin1a_d22	2144	1098	2664	517	CFG_VIN1A_D22_IN	-	-	-	-	vin3a_d6
AD3	vin1a_d23	2355	643	2816	0	CFG_VIN1A_D23_IN	-	-	-	-	vin3a_d7
AH7	vin1b_clk1	0	0	0	0	CFG_VIN1B_CLK1_IN	-	-	-	-	vin3a_clk0
B2	vin2a_d16	1624	239	1772	0	CFG_VIN2A_D16_IN	-	-	-	-	vin3a_d8
D6	vin2a_d17	1541	406	1838	0	CFG_VIN2A_D17_IN	-	-	-	-	vin3a_d9
C5	vin2a_d18	1942	313	2047	0	CFG_VIN2A_D18_IN	-	-	-	-	vin3a_d10
A3	vin2a_d19	1851	0	1667	0	CFG_VIN2A_D19_IN	-	-	-	-	vin3a_d11
B3	vin2a_d20	1837	430	2187	0	CFG_VIN2A_D20_IN	-	-	-	vin3a_de0	vin3a_d12
B4	vin2a_d21	1805	400	2042	0	CFG_VIN2A_D21_IN	-	-	-	vin3a_fld0	vin3a_d13
B5	vin2a_d22	1667	213	1786	0	CFG_VIN2A_D22_IN	-	-	-	vin3a_hsync0	vin3a_d14
A4	vin2a_d23	1700	408	2010	0	CFG_VIN2A_D23_IN	-	-	-	vin3a_vsync0	vin3a_d15
D11	vout1_clk	2405	379	2780	257	CFG_VOUT1_CLK_IN	-	vin4a_fld0	vin3a_fld0	-	-
F11	vout1_d0	2475	548	2806	469	CFG_VOUT1_D0_IN	-	vin4a_d16	vin3a_d16	-	-
G10	vout1_d1	2382	554	2771	418	CFG_VOUT1_D1_IN	-	vin4a_d17	vin3a_d17	-	-
D7	vout1_d10	2379	420	2784	267	CFG_VOUT1_D10_IN	-	vin4a_d10	vin3a_d10	-	-
D8	vout1_d11	2472	453	2810	367	CFG_VOUT1_D11_IN	-	vin4a_d11	vin3a_d11	-	-
A5	vout1_d12	2370	401	2777	247	CFG_VOUT1_D12_IN	-	vin4a_d12	vin3a_d12	-	-
C6	vout1_d13	2437	375	2819	229	CFG_VOUT1_D13_IN	-	vin4a_d13	vin3a_d13	-	-
C8	vout1_d14	2466	433	2785	342	CFG_VOUT1_D14_IN	-	vin4a_d14	vin3a_d14	-	-
C7	vout1_d15	2465	383	2846	255	CFG_VOUT1_D15_IN	-	vin4a_d15	vin3a_d15	-	-
B7	vout1_d16	2411	236	2733	167	CFG_VOUT1_D16_IN	-	vin4a_d0	vin3a_d0	-	-
B8	vout1_d17	2541	435	2840	379	CFG_VOUT1_D17_IN	-	vin4a_d1	vin3a_d1	-	-
A7	vout1_d18	2451	244	2761	186	CFG_VOUT1_D18_IN	-	vin4a_d2	vin3a_d2	-	-
A8	vout1_d19	2366	0	2564	0	CFG_VOUT1_D19_IN	-	vin4a_d3	vin3a_d3	-	-

**Table 5-40. Manual Functions Mapping for VIP2 (continued)**

BALL	BALL NAME	VIP2_MANUAL 1		VIP2_MANUAL2		CFG REGISTER	MUXMODE				
		A_DELAY (ps)	G_DELAY (ps)	A_DELAY (ps)	G_DELAY (ps)		2	3	4	5	6
F10	vout1_d2	2373	639	2740	526	CFG_VOUT1_D2_IN	-	vin4a_d18	vin3a_d18	-	-
C9	vout1_d20	2381	578	2758	454	CFG_VOUT1_D20_IN	-	vin4a_d4	vin3a_d4	-	-
A9	vout1_d21	2349	104	2706	0	CFG_VOUT1_D21_IN	-	vin4a_d5	vin3a_d5	-	-
B9	vout1_d22	2372	248	2745	127	CFG_VOUT1_D22_IN	-	vin4a_d6	vin3a_d6	-	-
A10	vout1_d23	2088	392	2608	124	CFG_VOUT1_D23_IN	-	vin4a_d7	vin3a_d7	-	-
G11	vout1_d3	2475	523	2771	475	CFG_VOUT1_D3_IN	-	vin4a_d19	vin3a_d19	-	-
E9	vout1_d4	2481	458	2772	410	CFG_VOUT1_D4_IN	-	vin4a_d20	vin3a_d20	-	-
F9	vout1_d5	2335	451	2711	328	CFG_VOUT1_D5_IN	-	vin4a_d21	vin3a_d21	-	-
F8	vout1_d6	2485	461	2739	459	CFG_VOUT1_D6_IN	-	vin4a_d22	vin3a_d22	-	-
E7	vout1_d7	2496	514	2767	495	CFG_VOUT1_D7_IN	-	vin4a_d23	vin3a_d23	-	-
E8	vout1_d8	2459	492	2789	414	CFG_VOUT1_D8_IN	-	vin4a_d8	vin3a_d8	-	-
D9	vout1_d9	2463	532	2790	441	CFG_VOUT1_D9_IN	-	vin4a_d9	vin3a_d9	-	-
B10	vout1_de	2326	134	2713	0	CFG_VOUT1_DE_IN	-	vin4a_de0	vin3a_de0	-	-
B11	vout1_fld	0	0	0	0	CFG_VOUT1_FLD_IN	-	vin4a_clk0	vin3a_clk0	-	-
C11	vout1_hsync	2058	180	2456	0	CFG_VOUT1_HSYNC_IN	-	vin4a_hsync0	vin3a_hsync0	-	-
E11	vout1_vsync	2226	18	2332	0	CFG_VOUT1_VSYNC_IN	-	vin4a_vsync0	vin3a_vsync0	-	-

Manual IO Timings Modes must be used to ensure some IO timings for VIP2. See [Table 5-33, Modes Summary](#) for a list of IO timings requiring the use of Manual IO Timings Modes. See [Table 5-41, Manual Functions Mapping for VIP2 4A](#) for a definition of the Manual modes.

[Table 5-41](#) lists the A\_DELAY and G\_DELAY values needed to calculate the correct values to be set in the CFG\_x registers.

**Table 5-41. Manual Functions Mapping for VIP2 4A**

BALL	BALL NAME	VIP2_4A_MANUAL1		VIP2_4A_MANUAL2		CFG REGISTER	MUXMODE		
		A_DELAY (ps)	G_DELAY (ps)	A_DELAY (ps)	G_DELAY (ps)		3	4	5
R6	gpmc_a0	2108	183	2229	0	CFG_GPMC_A0_IN	-	vin4a_d0	-
T9	gpmc_a1	1977	152	2082	0	CFG_GPMC_A1_IN	-	vin4a_d1	-
P9	gpmc_a11	1973	0	1964	0	CFG_GPMC_A11_IN	-	vin4a_fld0	-
P4	gpmc_a12	0	0	0	0	CFG_GPMC_A12_IN	-	vin4a_clk0	-
R3	gpmc_a13	2042	263	2251	0	CFG_GPMC_A13_IN	-	vin4a_hsync0	-
T2	gpmc_a14	2124	726	2678	158	CFG_GPMC_A14_IN	-	vin4a_vsync0	-
U2	gpmc_a15	1922	307	2226	0	CFG_GPMC_A15_IN	-	vin4a_d8	-
U1	gpmc_a16	2082	318	2340	0	CFG_GPMC_A16_IN	-	vin4a_d9	-

Table 5-41. Manual Functions Mapping for VIP2 4A (continued)

BALL	BALL NAME	VIP2_4A_MANUAL1		VIP2_4A_MANUAL2		CFG REGISTER	MUXMODE		
		A_DELAY (ps)	G_DELAY (ps)	A_DELAY (ps)	G_DELAY (ps)		3	4	5
P3	gpmc_a17	1987	328	2216	0	CFG_GPMC_A17_IN	-	vin4a_d10	-
R2	gpmc_a18	1428	0	1323	0	CFG_GPMC_A18_IN	-	vin4a_d11	-
K7	gpmc_a19	1755	0	1599	0	CFG_GPMC_A19_IN	-	vin4a_d12	-
T6	gpmc_a2	2202	359	2518	0	CFG_GPMC_A2_IN	-	vin4a_d2	-
M7	gpmc_a20	1561	0	1394	0	CFG_GPMC_A20_IN	-	vin4a_d13	-
J5	gpmc_a21	1795	41	1665	0	CFG_GPMC_A21_IN	-	vin4a_d14	-
K6	gpmc_a22	1637	0	1454	0	CFG_GPMC_A22_IN	-	vin4a_d15	-
J7	gpmc_a23	1489	0	1492	0	CFG_GPMC_A23_IN	-	vin4a_fld0	-
T7	gpmc_a3	2131	389	2502	0	CFG_GPMC_A3_IN	-	vin4a_d3	-
P6	gpmc_a4	2179	275	2403	0	CFG_GPMC_A4_IN	-	vin4a_d4	-
R9	gpmc_a5	2013	281	2248	0	CFG_GPMC_A5_IN	-	vin4a_d5	-
R5	gpmc_a6	1989	0	1920	0	CFG_GPMC_A6_IN	-	vin4a_d6	-
P5	gpmc_a7	2338	106	2348	0	CFG_GPMC_A7_IN	-	vin4a_d7	-
N1	gpmc_advn_ale	1960	0	1927	0	CFG_GPMC_ADVN_ALE_IN	-	vin4a_vsync0	-
P7	gpmc_clk	1941	0	1901	0	CFG_GPMC_CLK_IN	-	vin4a_hsync0	vin4a_de0
H6	gpmc_cs1	1412	0	1282	0	CFG_GPMC_CS1_IN	-	vin4a_de0	-
D11	vout1_clk	2425	88	2765	20	CFG_VOUT1_CLK_IN	vin4a_fld0	-	-
F11	vout1_d0	2460	555	2772	515	CFG_VOUT1_D0_IN	vin4a_d16	-	-
G10	vout1_d1	2307	500	2725	354	CFG_VOUT1_D1_IN	vin4a_d17	-	-
D7	vout1_d10	2367	275	2755	160	CFG_VOUT1_D10_IN	vin4a_d10	-	-
D8	vout1_d11	2480	337	2788	301	CFG_VOUT1_D11_IN	vin4a_d11	-	-
A5	vout1_d12	2344	290	2744	162	CFG_VOUT1_D12_IN	vin4a_d12	-	-
C6	vout1_d13	2381	184	2779	56	CFG_VOUT1_D13_IN	vin4a_d13	-	-
C8	vout1_d14	2459	533	2752	512	CFG_VOUT1_D14_IN	vin4a_d14	-	-
C7	vout1_d15	2386	263	2811	111	CFG_VOUT1_D15_IN	vin4a_d15	-	-
B7	vout1_d16	2378	197	2705	142	CFG_VOUT1_D16_IN	vin4a_d0	-	-
B8	vout1_d17	2538	171	2837	133	CFG_VOUT1_D17_IN	vin4a_d1	-	-
A7	vout1_d18	2433	69	2749	25	CFG_VOUT1_D18_IN	vin4a_d2	-	-
A8	vout1_d19	2158	0	2412	0	CFG_VOUT1_D19_IN	vin4a_d3	-	-
F10	vout1_d2	2401	291	2753	211	CFG_VOUT1_D2_IN	vin4a_d18	-	-
C9	vout1_d20	2361	401	2741	295	CFG_VOUT1_D20_IN	vin4a_d4	-	-
A9	vout1_d21	2181	0	2454	0	CFG_VOUT1_D21_IN	vin4a_d5	-	-

**Table 5-41. Manual Functions Mapping for VIP2 4A (continued)**

BALL	BALL NAME	VIP2_4A_MANUAL1		VIP2_4A_MANUAL2		CFG REGISTER	MUXMODE		
		A_DELAY (ps)	G_DELAY (ps)	A_DELAY (ps)	G_DELAY (ps)		3	4	5
B9	vout1_d22	2276	0	2548	0	CFG_VOUT1_D22_IN	vin4a_d6	-	-
A10	vout1_d23	2070	274	2591	26	CFG_VOUT1_D23_IN	vin4a_d7	-	-
G11	vout1_d3	2419	403	2749	341	CFG_VOUT1_D3_IN	vin4a_d19	-	-
E9	vout1_d4	2465	311	2754	294	CFG_VOUT1_D4_IN	vin4a_d20	-	-
F9	vout1_d5	2306	319	2696	201	CFG_VOUT1_D5_IN	vin4a_d21	-	-
F8	vout1_d6	2450	312	2716	318	CFG_VOUT1_D6_IN	vin4a_d22	-	-
E7	vout1_d7	2477	403	2747	405	CFG_VOUT1_D7_IN	vin4a_d23	-	-
E8	vout1_d8	2407	425	2744	360	CFG_VOUT1_D8_IN	vin4a_d8	-	-
D9	vout1_d9	2512	277	2783	278	CFG_VOUT1_D9_IN	vin4a_d9	-	-
B10	vout1_de	2266	36	2576	0	CFG_VOUT1_DE_IN	vin4a_de0	-	-
B11	vout1_fld	0	0	0	0	CFG_VOUT1_FLD_IN	vin4a_clk0	-	-
C11	vout1_hsync	2016	50	2300	0	CFG_VOUT1_HSYNC_IN	vin4a_hsync0	-	-
E11	vout1_vsync	1953	0	2088	0	CFG_VOUT1_VSYNC_IN	vin4a_vsync0	-	-

Manual IO Timings Modes must be used to ensure some IO timings for VIP2. See [Table 5-33, Modes Summary](#) for a list of IO timings requiring the use of Manual IO Timings Modes. See [Table 5-42, Manual Functions Mapping for VIP2 4A IOSET3](#) for a definition of the Manual modes.

[Table 5-42](#) lists the A\_DELAY and G\_DELAY values needed to calculate the correct values to be set in the CFG\_x registers.

**Table 5-42. Manual Functions Mapping for VIP2 4A IOSET3**

BALL	BALL NAME	VIP2_4A_IOSET3_MANUAL1		VIP2_4A_IOSET3_MANUAL2		CFG REGISTER	MUXMODE
		A_DELAY (ps)	G_DELAY (ps)	A_DELAY (ps)	G_DELAY (ps)		8
E21	gpio6_14	599	0	901	0	CFG_GPIO6_14_IN	vin4a_hsync0
F20	gpio6_15	1291	0	1593	0	CFG_GPIO6_15_IN	vin4a_vsync0
F21	gpio6_16	926	0	1228	0	CFG_GPIO6_16_IN	vin4a_fld0
B14	mcasp1_aclkr	1768	0	2071	0	CFG_MCASP1_ACLKR_IN	vin4a_d0
G13	mcasp1_axr2	2326	851	2737	792	CFG_MCASP1_AXR2_IN	vin4a_d2
J11	mcasp1_axr3	2406	562	2858	434	CFG_MCASP1_AXR3_IN	vin4a_d3
E12	mcasp1_axr4	2219	678	2742	464	CFG_MCASP1_AXR4_IN	vin4a_d4
F13	mcasp1_axr5	2226	676	2728	517	CFG_MCASP1_AXR5_IN	vin4a_d5
C12	mcasp1_axr6	2265	510	2806	271	CFG_MCASP1_AXR6_IN	vin4a_d6
D12	mcasp1_axr7	2302	781	2708	726	CFG_MCASP1_AXR7_IN	vin4a_d7
J14	mcasp1_fsr	1901	184	2386	0	CFG_MCASP1_FSR_IN	vin4a_d1

**Table 5-42. Manual Functions Mapping for VIP2 4A IOSET3 (continued)**

BALL	BALL NAME	VIP2_4A_IOSET3_MANUAL1		VIP2_4A_IOSET3_MANUAL2		CFG REGISTER	MUXMODE	
		A_DELAY (ps)	G_DELAY (ps)	A_DELAY (ps)	G_DELAY (ps)		8	
E15	mcasp2_aclkr	1555	0	1857	0	CFG_MCASP2_ACLKR_IN	vin4a_d8	
B15	mcasp2_axr0	1790	658	2407	343	CFG_MCASP2_AXR0_IN	vin4a_d10	
A15	mcasp2_axr1	1939	279	2527	0	CFG_MCASP2_AXR1_IN	vin4a_d11	
D15	mcasp2_axr4	1924	369	2541	53	CFG_MCASP2_AXR4_IN	vin4a_d12	
B16	mcasp2_axr5	1719	400	2337	84	CFG_MCASP2_AXR5_IN	vin4a_d13	
B17	mcasp2_axr6	1116	0	1418	0	CFG_MCASP2_AXR6_IN	vin4a_d14	
A17	mcasp2_axr7	1477	362	2094	47	CFG_MCASP2_AXR7_IN	vin4a_d15	
A20	mcasp2_fsr	1521	8	1830	0	CFG_MCASP2_FSR_IN	vin4a_d9	
C18	mcasp4_aclkx	1258	0	1418	0	CFG_MCASP4_ACLKX_IN	vin4a_d16	
G16	mcasp4_axr0	2334	227	2813	26	CFG_MCASP4_AXR0_IN	vin4a_d18	
D17	mcasp4_axr1	2334	529	2777	437	CFG_MCASP4_AXR1_IN	vin4a_d19	
A21	mcasp4_fsx	2293	0	2570	0	CFG_MCASP4_FSX_IN	vin4a_d17	
AA3	mcasp5_aclkx	3053	2527	3352	2409	CFG_MCASP5_ACLKX_IN	vin4a_d20	
AB3	mcasp5_axr0	3058	3254	3315	3285	CFG_MCASP5_AXR0_IN	vin4a_d22	
AA4	mcasp5_axr1	3090	3358	3331	3446	CFG_MCASP5_AXR1_IN	vin4a_d23	
AB9	mcasp5_fsx	3060	2699	3329	2686	CFG_MCASP5_FSX_IN	vin4a_d21	
B26	xref_clk2	0	0	0	0	CFG_XREF_CLK2_IN	vin4a_clk0	
C23	xref_clk3	962	0	1265	0	CFG_XREF_CLK3_IN	vin4a_de0	

Manual IO Timings Modes must be used to ensure some IO timings for VIP2. See [Table 5-33, Modes Summary](#) for a list of IO timings requiring the use of Manual IO Timings Modes. See [Table 5-43, Manual Functions Mapping for VIP2 4B](#) for a definition of the Manual modes.

[Table 5-43](#) lists the A\_DELAY and G\_DELAY values needed to calculate the correct values to be set in the CFG\_x registers.

**Table 5-43. Manual Functions Mapping for VIP2 4B**

BALL	BALL NAME	VIP2_4B_MANUAL1		VIP2_4B_MANUAL2		CFG REGISTER	MUXMODE	
		A_DELAY (ps)	G_DELAY (ps)	A_DELAY (ps)	G_DELAY (ps)		5	6
R6	gpmc_a0	2199	621	2416	398	CFG_GPMC_A0_IN	-	vin4b_d0
T9	gpmc_a1	1989	612	2267	323	CFG_GPMC_A1_IN	-	vin4b_d1
N9	gpmc_a10	0	0	0	0	CFG_GPMC_A10_IN	-	vin4b_clk1
P9	gpmc_a11	2133	859	2303	720	CFG_GPMC_A11_IN	-	vin4b_de1
P4	gpmc_a12	2258	562	2399	393	CFG_GPMC_A12_IN	-	vin4b_fld1
T6	gpmc_a2	2218	912	2365	720	CFG_GPMC_A2_IN	-	vin4b_d2



**Table 5-43. Manual Functions Mapping for VIP2 4B (continued)**

BALL	BALL NAME	VIP2_4B_MANUAL1		VIP2_4B_MANUAL2		CFG REGISTER	MUXMODE	
		A_DELAY (ps)	G_DELAY (ps)	A_DELAY (ps)	G_DELAY (ps)		5	6
T7	gpmc_a3	2168	963	2341	781	CFG_GPMC_A3_IN	-	vin4b_d3
P6	gpmc_a4	2196	813	2362	594	CFG_GPMC_A4_IN	-	vin4b_d4
R9	gpmc_a5	2082	782	2329	525	CFG_GPMC_A5_IN	-	vin4b_d5
R5	gpmc_a6	2098	407	2320	171	CFG_GPMC_A6_IN	-	vin4b_d6
P5	gpmc_a7	2343	585	2522	305	CFG_GPMC_A7_IN	-	vin4b_d7
N7	gpmc_a8	2030	685	2290	284	CFG_GPMC_A8_IN	-	vin4b_hsync1
R4	gpmc_a9	2116	832	2335	548	CFG_GPMC_A9_IN	-	vin4b_vsync1
U4	mdio_d	1860	189	2164	0	CFG_MDIO_D_IN	vin4b_d0	-
V1	mdio_mclk	0	0	0	0	CFG_MDIO_MCLK_IN	vin4b_clk1	-
U5	rgmii0_rxc	1965	550	2306	279	CFG_RGMII0_RXC_IN	vin4b_d5	-
V5	rgmii0_rxctl	1911	605	2235	369	CFG_RGMII0_RXCTL_IN	vin4b_d6	-
W2	rgmii0_rxd0	1954	304	2294	26	CFG_RGMII0_RXD0_IN	vin4b fld1	-
V4	rgmii0_rxd3	1925	835	2252	613	CFG_RGMII0_RXD3_IN	vin4b_d7	-
W9	rgmii0_txc	1937	849	2291	633	CFG_RGMII0_TXC_IN	vin4b_d3	-
V9	rgmii0_txctl	1997	872	2272	744	CFG_RGMII0_TXCTL_IN	vin4b_d4	-
V6	rgmii0_txd1	1989	771	2264	643	CFG_RGMII0_TXD1_IN	vin4b_vsync1	-
U7	rgmii0_txd2	1788	682	2193	334	CFG_RGMII0_TXD2_IN	vin4b_hsync1	-
V7	rgmii0_txd3	2091	591	2345	411	CFG_RGMII0_TXD3_IN	vin4b_de1	-
V2	uart3_rxd	1711	0	1699	0	CFG_UART3_RXD_IN	vin4b_d1	-
Y1	uart3_txd	1830	318	2176	0	CFG_UART3_TXD_IN	vin4b_d2	-

Manual IO Timings Modes must be used to ensure some IO timings for VIP2. See [Table 5-33, Modes Summary](#) for a list of IO timings requiring the use of Manual IO Timings Modes. See [Table 5-44, Manual Functions Mapping for VIP2 3B IOSET2](#) for a definition of the Manual modes.

[Table 5-44](#) lists the A\_DELAY and G\_DELAY values needed to calculate the correct values to be set in the CFG\_x registers.

**Table 5-44. Manual Functions Mapping for VIP2 3B IOSET2**

BALL	BALL NAME	VIP2_3B_IOSET2_MANUAL1		VIP2_3B_IOSET2_MANUAL2		CFG REGISTER	MUXMODE	
		A_DELAY (ps)	G_DELAY (ps)	A_DELAY (ps)	G_DELAY (ps)		4	6
K7	gpmc_a19	1801	826	2145	501	CFG_GPMC_A19_IN	-	vin3b_d0
M7	gpmc_a20	1706	697	2037	373	CFG_GPMC_A20_IN	-	vin3b_d1
J5	gpmc_a21	1767	937	2101	612	CFG_GPMC_A21_IN	-	vin3b_d2
K6	gpmc_a22	1678	895	1998	584	CFG_GPMC_A22_IN	-	vin3b_d3

Table 5-44. Manual Functions Mapping for VIP2 3B IOSET2 (continued)

BALL	BALL NAME	VIP2_3B_IOSET2_MANUAL1		VIP2_3B_IOSET2_MANUAL2		CFG REGISTER	MUXMODE	
		A_DELAY (ps)	G_DELAY (ps)	A_DELAY (ps)	G_DELAY (ps)		4	6
J7	gpmc_a23	1680	769	2016	619	CFG_GPMC_A23_IN	-	vin3b_d4
J4	gpmc_a24	1585	1015	1931	690	CFG_GPMC_A24_IN	-	vin3b_d5
J6	gpmc_a25	1643	893	2001	531	CFG_GPMC_A25_IN	-	vin3b_d6
H4	gpmc_a26	1627	958	1978	586	CFG_GPMC_A26_IN	-	vin3b_d7
H5	gpmc_a27	1709	686	2036	412	CFG_GPMC_A27_IN	-	vin3b_hsync1
N6	gpmc_ben0	1993	579	2297	340	CFG_GPMC_BEN0_IN	-	vin3b_de1
M4	gpmc_ben1	0	0	0	0	CFG_GPMC_BEN1_IN	vin3b_clk1	vin3b_fld1
H6	gpmc_cs1	1492	850	1829	486	CFG_GPMC_CS1_IN	-	vin3b_vsync1

#### 5.10.6.4 DSS

Three Display Parallel Interfaces (DPI) channels are available in DSS named DPI Video Output 1, DPI Video Output 2 and DPI Video Output 3.

#### NOTE

The DPI Video Output  $i$  ( $i = 1$  to 3) interface is also referred to as VOUT $i$ .

Every VOUT interface consists of:

- 24-bit data bus (data[23:0])
- Horizontal synchronization signal (HSYNC)
- Vertical synchronization signal (VSYNC)
- Data enable (DE)
- Field ID (FID)
- Pixel clock (CLK)

#### NOTE

For more information, see *Display Subsystem* chapter in the device TRM.

#### CAUTION

The IO timings provided in this section are only valid if signals within a single IOSET are used. The IOSETs are defined in the [Table 5-49](#) and [Table 5-50](#).

#### CAUTION

The IO Timings provided in this section are only valid for some DSS usage modes when the corresponding Virtual IO Timings or Manual IO Timings are configured as described in the tables found in this section.

#### CAUTION

All pads/balls configured as vout $i$ \_\* signals are recommended to use slow slew rate by setting the corresponding CTRL\_CORE\_PAD\_\*[SLEWCONTROL] register field to SLOW (0b1). FAST slew setting is allowed, but results in faster edge rates on the VOUT $n$  bus, higher power/ground noise, and higher EMI emissions compared to SLOW slew rate.

[Table 5-45](#), [Table 5-46](#) and [Figure 5-23](#) assume testing over the recommended operating conditions and electrical characteristic conditions.

**Table 5-45. DPI Video Output  $i$  ( $i = 1..3$ ) Default Switching Characteristics**

NO.	PARAMETER	DESCRIPTION	MODE	MIN	MAX	UNIT
D1	$t_{c(\text{clk})}$	Cycle time, output pixel clock vout $i$ _clk		11.76 <sup>(2)</sup>		ns
D2	$t_{w(\text{clkL})}$	Pulse duration, output pixel clock vout $i$ _clk low		P*0.5-1 <sup>(1)</sup>		ns
D3	$t_{w(\text{clkH})}$	Pulse duration, output pixel clock vout $i$ _clk high		P*0.5-1 <sup>(1)</sup>		ns

**Table 5-45. DPI Video Output i (i = 1..3) Default Switching Characteristics (continued)**

NO.	PARAMETER	DESCRIPTION	MODE	MIN	MAX	UNIT
D5	$t_{d(\text{clk-dV})}$	Delay time, output pixel clock vouti_clk transition to output data vouti_d[23:0] valid		-2.5	2.5	ns
D6	$t_{d(\text{clk-ctlV})}$	Delay time, output pixel clock vouti_clk transition to output control signals vouti_vsync, vouti_hsync, vouti_de, and vouti_fld valid		-2.5	2.5	ns

(1) P = output vouti\_clk period in ns.

(2) SERDES transceivers may be sensitive to the jitter profile of vouti\_clk. See Application Note [SPRAC62](#) for additional guidance.

**Table 5-46. DPI Video Output i (i = 1..3) Alternate Switching Characteristics**

NO.	PARAMETER	DESCRIPTION	MODE	MIN	MAX	UNIT
D1	$t_{c(\text{clk})}$	Cycle time, output pixel clock vouti_clk		6.06 <sup>(2)</sup>		ns
D2	$t_{w(\text{clkL})}$	Pulse duration, output pixel clock vouti_clk low		P*0.5-1 <sup>(1)</sup>		ns
D3	$t_{w(\text{clkH})}$	Pulse duration, output pixel clock vouti_clk high		P*0.5-1 <sup>(1)</sup>		ns
D5	$t_{d(\text{clk-ctlV})}$	Delay time, output pixel clock vouti_clk transition to output data vouti_d[23:0] valid		1.51	4.55	ns
D6	$t_{d(\text{clk-dV})}$	Delay time, output pixel clock vouti_clk transition to output control signals vouti_vsync, vouti_hsync, vouti_de, and vouti_fld valid		1.51	4.55	ns

(1) P = output vouti\_clk period in ns.

(2) SERDES transceivers may be sensitive to the jitter profile of vouti\_clk. See Application Note [SPRAC62](#) for additional guidance.

**Table 5-47. DPI Video Output i (i = 1..3) MANUAL3 Switching Characteristics**

NO.	PARAMETER	DESCRIPTION	MODE	MIN	MAX	UNIT
D1	$t_{c(\text{clk})}$	Cycle time, output pixel clock vouti_clk		6.06 <sup>(2)</sup>		ns
D2	$t_{w(\text{clkL})}$	Pulse duration, output pixel clock vouti_clk low		P*0.5-1 <sup>(1)</sup>		ns
D3	$t_{w(\text{clkH})}$	Pulse duration, output pixel clock vouti_clk high		P*0.5-1 <sup>(1)</sup>		ns
D5	$t_{d(\text{clk-ctlV})}$	Delay time, output pixel clock vouti_clk transition to output data vouti_d[23:0] valid		2.85	5.56	ns
D6	$t_{d(\text{clk-dV})}$	Delay time, output pixel clock vouti_clk transition to output control signals vouti_vsync, vouti_hsync, vouti_de, and vouti_fld valid		2.85	5.56	ns

(1) P = output vouti\_clk period in ns.

(2) SERDES transceivers may be sensitive to the jitter profile of vouti\_clk. See Application Note [SPRAC62](#) for additional guidance.

**Table 5-48. DPI Video Output i (i = 1..3) MANUAL4 Switching Characteristics**

NO.	PARAMETER	DESCRIPTION	MODE	MIN	MAX	UNIT
D1	$t_{c(\text{clk})}$	Cycle time, output pixel clock vouti_clk		6.06 <sup>(2)</sup>		ns
D2	$t_{w(\text{clkL})}$	Pulse duration, output pixel clock vouti_clk low		P*0.5-1 <sup>(1)</sup>		ns
D3	$t_{w(\text{clkH})}$	Pulse duration, output pixel clock vouti_clk high		P*0.5-1 <sup>(1)</sup>		ns
D5	$t_{d(\text{clk-ctlV})}$	Delay time, output pixel clock vouti_clk transition to output data vouti_d[23:0] valid		3.55	6.61	ns
D6	$t_{d(\text{clk-dV})}$	Delay time, output pixel clock vouti_clk transition to output control signals vouti_vsync, vouti_hsync, vouti_de, and vouti_fld valid		3.55	6.61	ns

- (1) P = output vouti\_clk period in ns.
- (2) SERDES transceivers may be sensitive to the jitter profile of vouti\_clk. See Application Note [SPRAC62](#) for additional guidance.

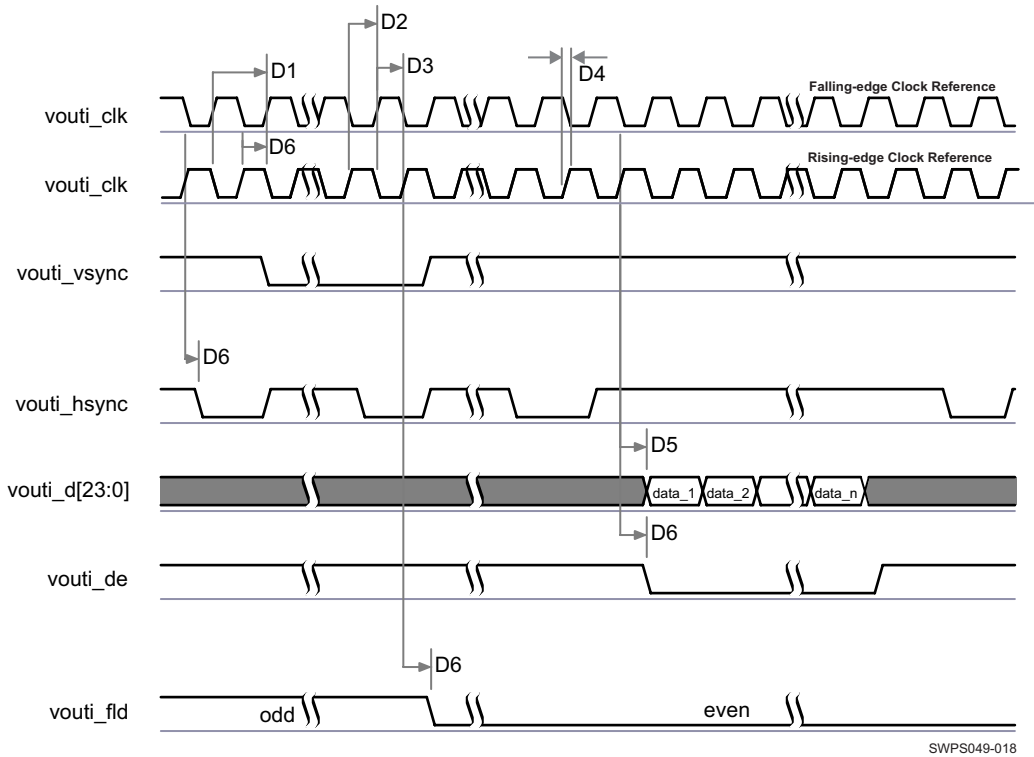

SWPS049-018

**Figure 5-23. DPI Video Output<sup>(1)(2)(3)</sup>**

- (1) The configuration of assertion of the data can be programmed on the falling or rising edge of the pixel clock.
- (2) The polarity and the pulse width of vouti\_hsync and vouti\_vsync are programmable, refer to section DSS in the device TRM.
- (3) The vouti\_clk frequency can be configured, refer to section DSS in the device TRM.

**NOTE**

To configure the desired virtual mode the user must set MODESELECT bit and DELAYMODE bit field for each corresponding pad control register.

The pad control registers are presented in [Table 4-33](#) and described in chapter Control Module in the device TRM.

In [Table 5-49](#) are presented the specific groupings of signals (IOSET) for use with VOUT2.

**Table 5-49. VOUT2 IOSETs**

SIGNALS	IOSET1		IOSET2	
	BALL	MUX	BALL	MUX
vout2_d23	F2	4	AA4	6
vout2_d22	F3	4	AB3	6
vout2_d21	D1	4	AB9	6
vout2_d20	E2	4	AA3	6
vout2_d19	D2	4	D17	6
vout2_d18	F4	4	G16	6
vout2_d17	C1	4	A21	6
vout2_d16	E4	4	C18	6
vout2_d15	F5	4	A17	6

**Table 5-49. VOUT2 IOSETs (continued)**

SIGNALS	IOSET1		IOSET2	
	BALL	MUX	BALL	MUX
vout2_d14	E6	4	B17	6
vout2_d13	D3	4	B16	6
vout2_d12	F6	4	D15	6
vout2_d11	D5	4	A15	6
vout2_d10	C2	4	B15	6
vout2_d9	C3	4	A20	6
vout2_d8	C4	4	E15	6
vout2_d7	B2	4	D12	6
vout2_d6	D6	4	C12	6
vout2_d5	C5	4	F13	6
vout2_d4	A3	4	E12	6
vout2_d3	B3	4	J11	6
vout2_d2	B4	4	G13	6
vout2_d1	B5	4	J14	6
vout2_d0	A4	4	B14	6
vout2_vsync	G6	4	F20	6
vout2_hsync	G1	4	E21	6
vout2_clk	H7	4	B26	6
vout2 fld	E1	4	F21	6
vout2_de	G2	4	C23	6

In [Table 5-50](#) are presented the specific groupings of signals (IOSET) for use with VOUT3.

**Table 5-50. VOUT3 IOSETs**

SIGNALS	IOSET1		IOSET2		IOSET3	
	BALL	MUX	BALL	MUX	BALL	MUX
vout3_d23	P5	3	AE8	4		
vout3_d22	R5	3	AD8	4		
vout3_d21	R9	3	AG7	4		
vout3_d20	P6	3	AH6	4		
vout3_d19	T7	3	AH3	4		
vout3_d18	T6	3	AH5	4		
vout3_d17	T9	3	AG6	4	AD9	3
vout3_d16	R6	3	AH4	4	AG8	3
vout3_d15	H3	3	AG4	4	AG4	4
vout3_d14	H2	3	AG2	4	AG2	4
vout3_d13	J3	3	AG3	4	AG3	4
vout3_d12	H1	3	AG5	4	AG5	4
vout3_d11	J2	3	AF2	4	AF2	4
vout3_d10	J1	3	AF6	4	AF6	4
vout3_d9	K2	3	AF3	4	AF3	4
vout3_d8	L1	3	AF4	4	AF4	4
vout3_d7	L2	3	AF1	4	AE8	3
vout3_d6	L3	3	AE3	4	AD8	3
vout3_d5	L4	3	AE5	4	AG7	3
vout3_d4	L6	3	AE1	4	AH6	3
vout3_d3	M1	3	AE2	4	AH3	3

**Table 5-50. VOUT3 IOSETs (continued)**

SIGNALS	IOSET1		IOSET2		IOSET3	
	BALL	MUX	BALL	MUX	BALL	MUX
vout3_d2	L5	3	AE6	4	AH5	3
vout3_d1	M2	3	AD2	4	AG6	3
vout3_d0	M6	3	AD3	4	AH4	3
vout3_de	N9	3	AD9	4		
vout3_vsync	R4	3	AF8	4	AF8	4
vout3_clk	P1	3	AF9	4	AF9	4
vout3_hsync	N7	3	AE9	4	AE9	4
vout3_fld	P9	3	AG8	4		

**NOTE**

To configure the desired manual IO timing mode the user must follow the steps described in *Manual IO Timing Modes* section in the device TRM.

The associated registers to configure are listed in the **CFG REGISTER** column. For more information, see *Control Module* chapter in the device TRM.

Manual IO Timings Modes must be used to ensure some IO timings for VOUT1. See [Table 5-33, Modes Summary](#) for a list of IO timings requiring the use of Manual IO Timings Modes. See [Table 5-51, Manual Functions Mapping for DSS VOUT1](#) for a definition of the Manual modes.

[Table 5-51](#) lists the A\_DELAY and G\_DELAY values needed to calculate the correct values to be set in the CFG\_x registers.

**Table 5-51. Manual Functions Mapping for DSS VOUT1**

BALL	BALL NAME	VOUT1_MANUAL1		VOUT1_MANUAL2		VOUT1_MANUAL3		VOUT1_MANUAL4		CFG REGISTER	MUXMODE
		A_DELAY (ps)	G_DELAY (ps)	A_DELAY (ps)	G_DELAY (ps)	A_DELAY (ps)	G_DELAY (ps)	A_DELAY (ps)	G_DELAY (ps)		0
D11	vout1_clk	0	29	1281	497	0	0	0	0	CFG_VOUT1_CLK_OUT	vout1_clk
F11	vout1_d0	1878	0	379	0	3126	0	4185	0	CFG_VOUT1_D0_OUT	vout1_d0
G10	vout1_d1	1978	0	475	0	3226	0	4284	0	CFG_VOUT1_D1_OUT	vout1_d1
D7	vout1_d10	1943	0	441	0	3191	0	4249	0	CFG_VOUT1_D10_OUT	vout1_d10
D8	vout1_d11	1964	0	461	0	3212	0	4271	0	CFG_VOUT1_D11_OUT	vout1_d11
A5	vout1_d12	2726	0	1189	0	3974	0	5033	0	CFG_VOUT1_D12_OUT	vout1_d12
C6	vout1_d13	1807	0	312	0	3055	0	4114	0	CFG_VOUT1_D13_OUT	vout1_d13
C8	vout1_d14	1793	0	298	0	3041	0	4099	0	CFG_VOUT1_D14_OUT	vout1_d14
C7	vout1_d15	1778	0	284	0	3026	0	4085	0	CFG_VOUT1_D15_OUT	vout1_d15
B7	vout1_d16	1652	0	152	0	2887	0	3946	0	CFG_VOUT1_D16_OUT	vout1_d16
B8	vout1_d17	1706	0	216	0	2954	0	4013	0	CFG_VOUT1_D17_OUT	vout1_d17
A7	vout1_d18	1908	0	408	0	3156	0	4215	0	CFG_VOUT1_D18_OUT	vout1_d18
A8	vout1_d19	2024	0	519	0	3272	0	4330	0	CFG_VOUT1_D19_OUT	vout1_d19
F10	vout1_d2	1757	0	264	0	3005	0	4064	0	CFG_VOUT1_D2_OUT	vout1_d2
C9	vout1_d20	1811	0	316	0	3059	0	4118	0	CFG_VOUT1_D20_OUT	vout1_d20
A9	vout1_d21	1640	0	59	0	2814	0	3850	0	CFG_VOUT1_D21_OUT	vout1_d21
B9	vout1_d22	1712	0	221	0	2960	0	4019	0	CFG_VOUT1_D22_OUT	vout1_d22
A10	vout1_d23	1581	0	96	0	2829	0	3888	0	CFG_VOUT1_D23_OUT	vout1_d23
G11	vout1_d3	1921	0	421	0	3169	0	4228	0	CFG_VOUT1_D3_OUT	vout1_d3
E9	vout1_d4	2797	0	1257	0	4045	0	5104	0	CFG_VOUT1_D4_OUT	vout1_d4
F9	vout1_d5	1933	0	432	0	3181	0	4240	0	CFG_VOUT1_D5_OUT	vout1_d5
F8	vout1_d6	1937	0	436	0	3185	0	4244	0	CFG_VOUT1_D6_OUT	vout1_d6
E7	vout1_d7	1941	0	440	0	3189	0	4248	0	CFG_VOUT1_D7_OUT	vout1_d7
E8	vout1_d8	1701	0	81	100	2918	0	3977	0	CFG_VOUT1_D8_OUT	vout1_d8
D9	vout1_d9	1973	0	471	0	3221	0	4280	0	CFG_VOUT1_D9_OUT	vout1_d9
B10	vout1_de	1573	0	0	0	2747	0	3725	0	CFG_VOUT1_DE_OUT	vout1_de
B11	vout1_fld	1709	0	224	0	2983	0	4004	0	CFG_VOUT1_FLD_OUT	vout1_fld
C11	vout1_hsync	1514	0	0	0	2688	0	3666	0	CFG_VOUT1_HSYNC_OUT	vout1_hsync
E11	vout1_vsync	2316	0	815	0	3564	0	4623	0	CFG_VOUT1_VSYNC_OUT	vout1_vsync



Manual IO Timings Modes must be used to ensure some IO timings for VOUT2. See [Table 5-33, Modes Summary](#) for a list of IO timings requiring the use of Manual IO Timings Modes. See [Table 5-52, Manual Functions Mapping for DSS VOUT2 IOSET1](#) for a definition of the Manual modes.

[Table 5-52](#) lists the A\_DELAY and G\_DELAY values needed to calculate the correct values to be set in the CFG\_x registers.

**Table 5-52. Manual Functions Mapping for DSS VOUT2 IOSET1**

BALL	BALL NAME	VOUT2_IOSET1_MANUAL1		VOUT2_IOSET1_MANUAL2		VOUT2_IOSET1_MANUAL3		VOUT2_IOSET1_MANUAL4		CFG REGISTER	MUXMODE
		A_DELAY (ps)	G_DELAY (ps)	A_DELAY (ps)	G_DELAY (ps)	A_DELAY (ps)	G_DELAY (ps)	A_DELAY (ps)	G_DELAY (ps)		4
E1	vin2a_clk0	2587	0	1178	0	3748	0	4694	0	CFG_VIN2A_CLK0_OUT	vout2_fld
F2	vin2a_d0	2199	0	449	337	3360	0	4306	0	CFG_VIN2A_D0_OUT	vout2_d23
F3	vin2a_d1	2141	0	731	0	3302	0	4248	0	CFG_VIN2A_D1_OUT	vout2_d22
D3	vin2a_d10	1449	0	261	0	2810	0	3756	0	CFG_VIN2A_D10_OUT	vout2_d13
F6	vin2a_d11	2010	0	425	181	3171	0	4117	0	CFG_VIN2A_D11_OUT	vout2_d12
D5	vin2a_d12	2487	291	1649	73	3864	475	4680	605	CFG_VIN2A_D12_OUT	vout2_d11
C2	vin2a_d13	2235	363	1594	148	3812	548	4629	677	CFG_VIN2A_D13_OUT	vout2_d10
C3	vin2a_d14	2211	364	1456	167	3688	548	4504	678	CFG_VIN2A_D14_OUT	vout2_d9
C4	vin2a_d15	2462	128	1542	0	3839	312	4656	441	CFG_VIN2A_D15_OUT	vout2_d8
B2	vin2a_d16	2396	56	1554	0	3923	240	4740	370	CFG_VIN2A_D16_OUT	vout2_d7
D6	vin2a_d17	2426	130	1510	0	3803	314	4620	444	CFG_VIN2A_D17_OUT	vout2_d6
C5	vin2a_d18	2022	0	617	0	3183	0	4129	0	CFG_VIN2A_D18_OUT	vout2_d5
A3	vin2a_d19	1826	0	430	0	2987	0	3933	0	CFG_VIN2A_D19_OUT	vout2_d4
D1	vin2a_d2	1973	0	571	0	3134	0	4080	0	CFG_VIN2A_D2_OUT	vout2_d21
B3	vin2a_d20	1514	0	110	0	2668	0	3618	0	CFG_VIN2A_D20_OUT	vout2_d3
B4	vin2a_d21	1454	0	36	0	2608	0	3558	0	CFG_VIN2A_D21_OUT	vout2_d2
B5	vin2a_d22	1432	0	0	0	2586	0	3536	0	CFG_VIN2A_D22_OUT	vout2_d1
A4	vin2a_d23	1452	0	20	0	2606	0	3556	0	CFG_VIN2A_D23_OUT	vout2_d0
E2	vin2a_d3	2007	0	603	0	3168	0	4114	0	CFG_VIN2A_D3_OUT	vout2_d20
D2	vin2a_d4	2306	0	1366	0	3967	0	4913	0	CFG_VIN2A_D4_OUT	vout2_d19
F4	vin2a_d5	2122	0	904	0	3483	0	4429	0	CFG_VIN2A_D5_OUT	vout2_d18
C1	vin2a_d6	1867	0	660	0	3228	0	4174	0	CFG_VIN2A_D6_OUT	vout2_d17
E4	vin2a_d7	1940	0	539	0	3101	0	4047	0	CFG_VIN2A_D7_OUT	vout2_d16
F5	vin2a_d8	1752	0	359	0	2913	0	3859	0	CFG_VIN2A_D8_OUT	vout2_d15
E6	vin2a_d9	1631	0	46	198	2792	0	3738	0	CFG_VIN2A_D9_OUT	vout2_d14
G2	vin2a_de0	2136	0	726	0	3297	0	4243	0	CFG_VIN2A_DE0_OUT	vout2_de
H7	vin2a_fld0	0	274	1409	698	0	161	0	55	CFG_VIN2A_FLD0_OUT	vout2_clk

**Table 5-52. Manual Functions Mapping for DSS VOUT2 IOSET1 (continued)**

BALL	BALL NAME	VOUT2_IOSET1_MANUAL1		VOUT2_IOSET1_MANUAL2		VOUT2_IOSET1_MANUAL3		VOUT2_IOSET1_MANUAL4		CFG REGISTER	MUXMODE
		A_DELAY (ps)	G_DELAY (ps)	A_DELAY (ps)	G_DELAY (ps)	A_DELAY (ps)	G_DELAY (ps)	A_DELAY (ps)	G_DELAY (ps)		4
G1	vin2a_hsync0	2610	0	1200	0	3771	0	4717	0	CFG_VIN2A_HSYNC0_OUT	vout2_hsync
G6	vin2a_vsync0	2214	0	822	0	3375	0	4321	0	CFG_VIN2A_VSYNC0_OUT	vout2_vsync

Manual IO Timings Modes must be used to ensure some IO timings for VOUT2. See [Table 5-33, Modes Summary](#) for a list of IO timings requiring the use of Manual IO Timings Modes. See [Table 5-53, Manual Functions Mapping for DSS VOUT2 IOSET2](#) for a definition of the Manual modes.

[Table 5-53](#) lists the A\_DELAY and G\_DELAY values needed to calculate the correct values to be set in the CFG\_x registers.

**Table 5-53. Manual Functions Mapping for DSS VOUT2 IOSET2**

BALL	BALL NAME	VOUT2_IOSET2_MANUAL1		VOUT2_IOSET2_MANUAL2		VOUT2_IOSET2_MANUAL3		VOUT2_IOSET2_MANUAL4		CFG REGISTER	MUXMODE
		A_DELAY (ps)	G_DELAY (ps)	A_DELAY (ps)	G_DELAY (ps)	A_DELAY (ps)	G_DELAY (ps)	A_DELAY (ps)	G_DELAY (ps)		6
E21	gpio6_14	1193	0	274	0	2474	0	3298	0	CFG_GPIO6_14_OUT	vout2_hsync
F20	gpio6_15	1006	0	27	0	2226	0	3039	0	CFG_GPIO6_15_OUT	vout2_vsync
F21	gpio6_16	921	0	0	0	2141	0	2955	0	CFG_GPIO6_16_OUT	vout2_fid
B14	mcasp1_aclkr	3224	0	2192	0	4505	0	5328	0	CFG_MCASP1_ACLKR_OUT	vout2_d0
G13	mcasp1_axr2	2197	0	1211	0	3478	0	4302	0	CFG_MCASP1_AXR2_OUT	vout2_d2
J11	mcasp1_axr3	1989	0	1013	0	3271	0	4094	0	CFG_MCASP1_AXR3_OUT	vout2_d3
E12	mcasp1_axr4	2452	0	1455	0	3733	0	4557	0	CFG_MCASP1_AXR4_OUT	vout2_d4
F13	mcasp1_axr5	2507	0	1507	0	3788	0	4612	0	CFG_MCASP1_AXR5_OUT	vout2_d5
C12	mcasp1_axr6	2212	0	1225	0	3493	0	4316	0	CFG_MCASP1_AXR6_OUT	vout2_d6
D12	mcasp1_axr7	2204	0	1218	0	3485	0	4309	0	CFG_MCASP1_AXR7_OUT	vout2_d7
J14	mcasp1_fsr	1933	0	959	0	3214	0	4037	0	CFG_MCASP1_FSR_OUT	vout2_d1
E15	mcasp2_aclkr	3074	0	2048	0	4355	0	5178	0	CFG_MCASP2_ACLKR_OUT	vout2_d8
B15	mcasp2_axr0	1798	0	830	0	3080	0	3903	0	CFG_MCASP2_AXR0_OUT	vout2_d10
A15	mcasp2_axr1	2031	0	542	510	3312	0	4135	0	CFG_MCASP2_AXR1_OUT	vout2_d11
D15	mcasp2_axr4	2050	0	1071	0	3331	0	4155	0	CFG_MCASP2_AXR4_OUT	vout2_d12
B16	mcasp2_axr5	1627	0	667	0	2908	0	3732	0	CFG_MCASP2_AXR5_OUT	vout2_d13
B17	mcasp2_axr6	2924	0	1905	0	4205	0	5028	0	CFG_MCASP2_AXR6_OUT	vout2_d14
A17	mcasp2_axr7	1555	0	598	0	2836	0	3660	0	CFG_MCASP2_AXR7_OUT	vout2_d15
A20	mcasp2_fsr	1689	0	188	539	2971	0	3794	0	CFG_MCASP2_FSR_OUT	vout2_d9
C18	mcasp4_aclkx	2607	0	1603	0	3889	0	4712	0	CFG_MCASP4_ACLKX_OUT	vout2_d16

**Table 5-53. Manual Functions Mapping for DSS VOUT2 IOSET2 (continued)**

BALL	BALL NAME	VOUT2_IOSET2_MANUAL1		VOUT2_IOSET2_MANUAL2		VOUT2_IOSET2_MANUAL3		VOUT2_IOSET2_MANUAL4		CFG REGISTER	MUXMODE	
		A_DELAY (ps)	G_DELAY (ps)	A_DELAY (ps)	G_DELAY (ps)	A_DELAY (ps)	G_DELAY (ps)	A_DELAY (ps)	G_DELAY (ps)		6	
G16	mcasp4_axr0	1690	0	727	0	2971	0	3795	0	CFG_MCASP4_AXR0_OUT	vout2_d18	
D17	mcasp4_axr1	1408	0	457	0	2689	0	3512	0	CFG_MCASP4_AXR1_OUT	vout2_d19	
A21	mcasp4_fsx	1564	0	606	0	2845	0	3668	0	CFG_MCASP4_FSX_OUT	vout2_d17	
AA3	mcasp5_aclkx	4355	1633	3732	1100	5399	1869	6062	2030	CFG_MCASP5_ACLKX_OUT	vout2_d20	
AB3	mcasp5_axr0	4307	1362	3675	853	5352	1599	6014	1759	CFG_MCASP5_AXR0_OUT	vout2_d22	
AA4	mcasp5_axr1	4276	971	3633	492	5321	1208	5984	1369	CFG_MCASP5_AXR1_OUT	vout2_d23	
AB9	mcasp5_fsx	4272	981	3628	503	5317	1217	5980	1378	CFG_MCASP5_FSX_OUT	vout2_d21	
B26	xref_clk2	0	51	2016	507	0	0	0	0	CFG_XREF_CLK2_OUT	vout2_clk	
C23	xref_clk3	2331	0	1339	0	3612	0	4436	0	CFG_XREF_CLK3_OUT	vout2_de	

Manual IO Timings Modes must be used to ensure some IO timings for VOUT3. See [Table 5-33, Modes Summary](#) for a list of IO timings requiring the use of Manual IO Timings Modes. See [Table 5-54, Manual Functions Mapping for DSS VOUT3](#) for a definition of the Manual modes.

[Table 5-54](#) lists the A\_DELAY and G\_DELAY values needed to calculate the correct values to be set in the CFG\_x registers.

**Table 5-54. Manual Functions Mapping for DSS VOUT3**

BALL	BALL NAME	VOUT3_MANUAL1		VOUT3_MANUAL2		VOUT3_MANUAL3		VOUT3_MANUAL4		CFG REGISTER	MUXMODE	
		A_DELAY (ps)	G_DELAY (ps)	A_DELAY (ps)	G_DELAY (ps)	A_DELAY (ps)	G_DELAY (ps)	A_DELAY (ps)	G_DELAY (ps)		3	4
R6	gpmc_a0	1627	0	787	0	2798	0	3781	0	CFG_GPMC_A0_OUT	vout3_d16	-
T9	gpmc_a1	1527	0	592	0	2698	0	3680	0	CFG_GPMC_A1_OUT	vout3_d17	-
N9	gpmc_a10	1907	0	1181	0	3122	0	4194	0	CFG_GPMC_A10_OUT	vout3_de	-
P9	gpmc_a11	2406	0	1676	0	3622	0	4693	0	CFG_GPMC_A11_OUT	vout3 fld	-
T6	gpmc_a2	1508	0	641	0	2679	0	3661	0	CFG_GPMC_A2_OUT	vout3_d18	-
T7	gpmc_a3	2222	0	1481	0	3437	0	4508	0	CFG_GPMC_A3_OUT	vout3_d19	-
P6	gpmc_a4	2529	0	1775	0	3744	0	4815	0	CFG_GPMC_A4_OUT	vout3_d20	-
R9	gpmc_a5	1492	0	785	0	2708	0	3779	0	CFG_GPMC_A5_OUT	vout3_d21	-
R5	gpmc_a6	1578	0	848	0	2774	0	3845	0	CFG_GPMC_A6_OUT	vout3_d22	-
P5	gpmc_a7	1586	0	851	0	2778	0	3849	0	CFG_GPMC_A7_OUT	vout3_d23	-
N7	gpmc_a8	2519	0	1783	0	3734	0	4805	0	CFG_GPMC_A8_OUT	vout3_hsync	-
R4	gpmc_a9	1886	0	951	0	2864	0	3935	0	CFG_GPMC_A9_OUT	vout3_vsync	-
M6	gpmc_ad0	1813	0	1091	0	3028	0	4099	0	CFG_GPMC_AD0_OUT	vout3_d0	-

**Table 5-54. Manual Functions Mapping for DSS VOUT3 (continued)**

BALL	BALL NAME	VOUT3_MANUAL1		VOUT3_MANUAL2		VOUT3_MANUAL3		VOUT3_MANUAL4		CFG REGISTER	MUXMODE	
		A_DELAY (ps)	G_DELAY (ps)	A_DELAY (ps)	G_DELAY (ps)	A_DELAY (ps)	G_DELAY (ps)	A_DELAY (ps)	G_DELAY (ps)		3	4
M2	gpmc_ad1	1652	0	937	0	2868	0	3939	0	CFG_GPMC_AD1_OUT	vout3_d1	-
J1	gpmc_ad10	1746	0	1027	0	2962	0	4033	0	CFG_GPMC_AD10_OUT	vout3_d10	-
J2	gpmc_ad11	1534	0	824	0	2749	0	3820	0	CFG_GPMC_AD11_OUT	vout3_d11	-
H1	gpmc_ad12	1923	0	1196	0	3138	0	4209	0	CFG_GPMC_AD12_OUT	vout3_d12	-
J3	gpmc_ad13	1496	0	754	0	2676	0	3747	0	CFG_GPMC_AD13_OUT	vout3_d13	-
H2	gpmc_ad14	1379	0	665	0	2582	0	3653	0	CFG_GPMC_AD14_OUT	vout3_d14	-
H3	gpmc_ad15	1746	0	1027	0	2961	0	4032	0	CFG_GPMC_AD15_OUT	vout3_d15	-
L5	gpmc_ad2	1894	0	1168	0	3110	0	4181	0	CFG_GPMC_AD2_OUT	vout3_d2	-
M1	gpmc_ad3	1584	0	872	0	2800	0	3871	0	CFG_GPMC_AD3_OUT	vout3_d3	-
L6	gpmc_ad4	1815	0	1092	0	3030	0	4101	0	CFG_GPMC_AD4_OUT	vout3_d4	-
L4	gpmc_ad5	1436	0	576	0	2607	0	3589	0	CFG_GPMC_AD5_OUT	vout3_d5	-
L3	gpmc_ad6	1837	0	1113	0	3052	0	4123	0	CFG_GPMC_AD6_OUT	vout3_d6	-
L2	gpmc_ad7	1658	0	943	0	2874	0	3945	0	CFG_GPMC_AD7_OUT	vout3_d7	-
L1	gpmc_ad8	515	0	0	0	1686	0	2757	0	CFG_GPMC_AD8_OUT	vout3_d8	-
K2	gpmc_ad9	853	0	0	0	2024	0	3006	0	CFG_GPMC_AD9_OUT	vout3_d9	-
P1	gpmc_cs3	0	234	1801	948	0	167	0	177	CFG_GPMC_CS3_OUT	vout3_clk	-
AG8	vin1a_clk0	1954	0	1244	0	3240	0	4298	0	CFG_VIN1A_CLK0_OUT	vout3_d16	vout3_fld
AE8	vin1a_d0	1991	0	1261	0	3277	0	4336	0	CFG_VIN1A_D0_OUT	vout3_d7	vout3_d23
AD8	vin1a_d1	1911	0	1185	0	3197	0	4256	0	CFG_VIN1A_D1_OUT	vout3_d6	vout3_d22
AG3	vin1a_d10	2460	0	1647	0	3754	0	4813	0	CFG_VIN1A_D10_OUT	-	vout3_d13
AG5	vin1a_d11	2098	0	1302	0	3392	0	4451	0	CFG_VIN1A_D11_OUT	-	vout3_d12
AF2	vin1a_d12	2703	0	1880	0	3997	0	5056	0	CFG_VIN1A_D12_OUT	-	vout3_d11
AF6	vin1a_d13	2049	0	1255	0	3343	0	4402	0	CFG_VIN1A_D13_OUT	-	vout3_d10
AF3	vin1a_d14	2815	0	1987	0	4109	0	5131	37	CFG_VIN1A_D14_OUT	-	vout3_d9
AF4	vin1a_d15	1973	0	1183	0	3267	0	4326	0	CFG_VIN1A_D15_OUT	-	vout3_d8
AF1	vin1a_d16	2084	0	1289	0	3379	0	4437	0	CFG_VIN1A_D16_OUT	-	vout3_d7
AE3	vin1a_d17	2100	0	1304	0	3394	0	4453	0	CFG_VIN1A_D17_OUT	-	vout3_d6
AE5	vin1a_d18	2069	0	1274	0	3363	0	4422	0	CFG_VIN1A_D18_OUT	-	vout3_d5
AE1	vin1a_d19	2171	0	1372	0	3465	0	4524	0	CFG_VIN1A_D19_OUT	-	vout3_d4
AG7	vin1a_d2	1956	0	1227	0	3241	0	4300	0	CFG_VIN1A_D2_OUT	vout3_d5	vout3_d21
AE2	vin1a_d20	2251	0	1448	0	3546	0	4604	0	CFG_VIN1A_D20_OUT	-	vout3_d3
AE6	vin1a_d21	2252	0	1449	0	3546	0	4605	0	CFG_VIN1A_D21_OUT	-	vout3_d2

**Table 5-54. Manual Functions Mapping for DSS VOUT3 (continued)**

BALL	BALL NAME	VOUT3_MANUAL1		VOUT3_MANUAL2		VOUT3_MANUAL3		VOUT3_MANUAL4		CFG REGISTER	MUXMODE	
		A_DELAY (ps)	G_DELAY (ps)	A_DELAY (ps)	G_DELAY (ps)	A_DELAY (ps)	G_DELAY (ps)	A_DELAY (ps)	G_DELAY (ps)		3	4
AD2	vin1a_d22	2199	0	1187	211	3494	0	4552	0	CFG_VIN1A_D22_OUT	-	vout3_d1
AD3	vin1a_d23	2316	0	1510	0	3610	0	4669	0	CFG_VIN1A_D23_OUT	-	vout3_d0
AH6	vin1a_d3	2053	0	1320	0	3338	0	4397	0	CFG_VIN1A_D3_OUT	vout3_d4	vout3_d20
AH3	vin1a_d4	2760	0	1995	0	4045	0	5015	89	CFG_VIN1A_D4_OUT	vout3_d3	vout3_d19
AH5	vin1a_d5	1755	0	1007	0	3010	0	4069	0	CFG_VIN1A_D5_OUT	vout3_d2	vout3_d18
AG6	vin1a_d6	1948	0	1220	0	3233	0	4292	0	CFG_VIN1A_D6_OUT	vout3_d1	vout3_d17
AH4	vin1a_d7	1925	0	1198	0	3211	0	4270	0	CFG_VIN1A_D7_OUT	vout3_d0	vout3_d16
AG4	vin1a_d8	2104	0	1307	0	3398	0	4457	0	CFG_VIN1A_D8_OUT	-	vout3_d15
AG2	vin1a_d9	2192	0	1392	0	3487	0	4545	0	CFG_VIN1A_D9_OUT	-	vout3_d14
AD9	vin1a_de0	2202	0	1462	0	3487	0	4546	0	CFG_VIN1A_DE0_OUT	vout3_d17	vout3_de
AF9	vin1a_fld0	0	0	2007	454	0	0	0	0	CFG_VIN1A_FLD0_OUT	-	vout3_clk
AE9	vin1a_hsync0	2015	0	1240	0	3309	0	4367	0	CFG_VIN1A_HSYNC0_OUT	-	vout3_hsync
AF8	vin1a_vsync0	1829	0	1063	0	3123	0	4182	0	CFG_VIN1A_VSYNC0_OUT	-	vout3_vsync

### 5.10.6.5 HDMI

The High-Definition Multimedia Interface is provided for transmitting digital television audiovisual signals from DVD players, set-top boxes and other audiovisual sources to television sets, projectors and other video displays. The HDMI interface is aligned with the HDMI TMDS single stream standard v1.4a (720p @60Hz to 1080p @24Hz) and the HDMI v1.3 (1080p @60Hz): 3 data channels, plus 1 clock channel is supported (differential).

---

#### NOTE

For more information, see *High-Definition Multimedia Interface* section in the device TRM.

---

### 5.10.6.6 EMIF

The device has a dedicated interface to DDR3 SDRAM. It supports JEDEC standard compliant DDR3 SDRAM devices with the following features:

- 16-bit or 32-bit data path to external SDRAM memory
- Memory device capacity: 128Mb, 256Mb, 512Mb, 1Gb, 2Gb, 4Gb and 8Gb devices (Single die only)
- One interface with associated DDR3 PHYs

---

#### NOTE

For more information, see *EMIF Controller* section in the device TRM.

---

### 5.10.6.7 GPMC

The GPMC is the unified memory controller that interfaces external memory devices such as:

- Asynchronous SRAM-like memories and ASIC devices
- Asynchronous page mode and synchronous burst NOR flash
- NAND flash

---

#### NOTE

For more information, see *General-Purpose Memory Controller* section in the device TRM.

---

#### 5.10.6.7.1 GPMC/NOR Flash Interface Synchronous Timing

#### CAUTION

The IO Timings provided in this section are only valid for some GPMC usage modes when the corresponding Virtual IO Timings or Manual IO Timings are configured as described in the tables found in this section.

Table 5-55, Table 5-56, Table 5-57, Table 5-58, and Table 5-59 assume testing over the recommended operating conditions and electrical characteristic conditions below (see Figure 5-24, Figure 5-25, Figure 5-26, Figure 5-27, Figure 5-28, and Figure 5-29).

**Table 5-55. GPMC/NOR Flash Interface Timing Requirements - Synchronous Mode - Default Timing with Pad Loopback Clock**

NO.	PARAMETER	DESCRIPTION	MIN	MAX	UNIT
F12	$t_{su(dV-clkH)}$	Setup time, read gpmc_ad[15:0] valid before gpmc_clk high	1.9		ns
F13	$t_h(clkH-dV)$	Hold time, read gpmc_ad[15:0] valid after gpmc_clk high	1		ns
F21	$t_{su(waitV-clkH)}$	Setup time, gpmc_wait[1:0] valid before gpmc_clk high	1.9		ns

**Table 5-55. GPMC/NOR Flash Interface Timing Requirements - Synchronous Mode - Default Timing with Pad Loopback Clock (continued)**

NO.	PARAMETER	DESCRIPTION	MIN	MAX	UNIT
F22	$t_{h(\text{clkH-waitV})}$	Hold Time, gpmc_wait[1:0] valid after gpmc_clk high	1		ns

**Table 5-56. GPMC/NOR Flash Interface Timing Requirements - Synchronous Mode - Default Timing with Internal Loopback Clock**

NO.	PARAMETER	DESCRIPTION	MIN	MAX	UNIT
F12	$t_{su(dV-\text{clkH})}$	Setup time, read gpmc_ad[15:0] valid before gpmc_clk high	2.6		ns
F13	$t_{h(\text{clkH-dV})}$	Hold time, read gpmc_ad[15:0] valid after gpmc_clk high	1		ns
F21	$t_{su(\text{waitV}-\text{clkH})}$	Setup time, gpmc_wait[1:0] valid before gpmc_clk high	2.2		ns
F22	$t_{h(\text{clkH-waitV})}$	Hold Time, gpmc_wait[1:0] valid after gpmc_clk high	1		ns

---

**NOTE**

Wait monitoring support is limited to a WaitMonitoringTime value > 0. For a full description of wait monitoring feature, see General-Purpose Memory Controller section in the Device TRM.

---



---

**NOTE**

Pad loopback clock is enabled by default when bit 16 (SEL\_GPMC\_CLK\_INTLB) of CTRL\_CORE\_CONTROL\_SPARE\_RW is 0x0. Internal loopback clock is enabled by setting bit 16 (SEL\_GPMC\_CLK\_INTLB) of CTRL\_CORE\_CONTROL\_SPARE\_RW to 0x1.

---

**Table 5-57. GPMC/NOR Flash Interface Switching Characteristics - Synchronous Mode - Default Timing**

NO.	PARAMETER	DESCRIPTION	MIN	MAX	UNIT
F0	$t_{c(\text{clk})}$	Cycle time, output clock gpmc_clk period, pad loopback clock <sup>(12)</sup>	11.3		ns
		Cycle time, output clock gpmc_clk period, internal loopback clock <sup>(12)</sup>	7.5		ns
F2	$t_{d(\text{clkH-nCSV})}$	Delay time, gpmc_clk rising edge to gpmc_cs[7:0] transition <sup>(14)</sup>	F-0.8 <sup>(6)</sup>	F+3.17 <sup>(6)</sup>	ns
F3	$t_{d(\text{clkH-nCSIV})}$	Delay time, gpmc_clk rising edge to gpmc_cs[7:0] invalid <sup>(14)</sup>	E-0.8 <sup>(5)</sup>	E+3.1 <sup>(5)</sup>	ns
F4	$t_{d(\text{ADDV}-\text{clk})}$	Delay time, gpmc_a[27:0] address bus valid to gpmc_clk first edge	B-0.8 <sup>(2)</sup>	B+3.43 <sup>(2)</sup>	ns
F5	$t_{d(\text{clkH-ADDIV})}$	Delay time, gpmc_clk rising edge to gpmc_a[27:0] gpmc address bus invalid	-0.8		ns
F6	$t_{d(nBEV-\text{clk})}$	Delay time, gpmc_ben[1:0] valid to gpmc_clk rising edge	B-3.8	B+2.37	ns
F7	$t_{d(\text{clkH-nBEIV})}$	Delay time, gpmc_clk rising edge to gpmc_ben[1:0] invalid	D-0.4	D+1.1	ns
F8	$t_{d(\text{clkH-nADV})}$	Delay time, gpmc_clk rising edge to gpmc_advn_ale transition <sup>(14)</sup>	G-0.8 <sup>(7)</sup>	G+3.1 <sup>(7)</sup>	ns
F9	$t_{d(\text{clkH-nADVIV})}$	Delay time, gpmc_clk rising edge to gpmc_advn_ale invalid <sup>(14)</sup>	D-0.8 <sup>(4)</sup>	D+3.1 <sup>(4)</sup>	ns
F10	$t_{d(\text{clkH-nOE})}$	Delay time, gpmc_clk rising edge to gpmc_oen_ren transition <sup>(14)</sup>	H-0.8 <sup>(8)</sup>	H+2.45 <sup>(8)</sup>	ns
F11	$t_{d(\text{clkH-nOEIV})}$	Delay time, gpmc_clk rising edge to gpmc_oen_ren invalid <sup>(14)</sup>	E-0.8 <sup>(5)</sup>	E+2.1 <sup>(5)</sup>	ns
F14	$t_{d(\text{clkH-nWE})}$	Delay time, gpmc_clk rising edge to gpmc_wen transition <sup>(14)</sup>	I-0.8 <sup>(9)</sup>	I+3.1 <sup>(9)</sup>	ns
F15	$t_{d(\text{clkH-Data})}$	Delay time, gpmc_clk rising edge to gpmc_ad[15:0] data bus transition	J-1.1 <sup>(10)</sup>	J+4.89 <sup>(10)</sup>	ns
F17	$t_{d(\text{clkH-nBE})}$	Delay time, gpmc_clk rising edge to gpmc_ben[1:0] transition	J-1.1 <sup>(10)</sup>	J+3.8 <sup>(10)</sup>	ns
F18	$t_{w(nCSV)}$	Pulse duration, gpmc_cs[7:0] low	A <sup>(1)</sup>		ns
F19	$t_{w(nBEV)}$	Pulse duration, gpmc_ben[1:0] low	C <sup>(3)</sup>		ns
F20	$t_{w(nADV)}$	Pulse duration, gpmc_advn_ale low	K <sup>(11)</sup>		ns
F23	$t_{d(\text{CLK-GPIO})}$	Delay time, gpmc_clk transition to gpio6_16 transition <sup>(13)</sup>	1.2	6.1	ns

**Table 5-58. GPMC/NOR Flash Interface Timing Requirements - Synchronous Mode - Alternate Timing with Pad Loopback Clock**

NO.	PARAMETER	DESCRIPTION	MIN	MAX	UNIT
F12	$t_{su(dV-clkH)}$	Setup time, read gpmc_ad[15:0] valid before gpmc_clk high	2.5		ns
F13	$t_h(clkH-dV)$	Hold time, read gpmc_ad[15:0] valid after gpmc_clk high	1.9		ns
F21	$t_{su(waitV-clkH)}$	Setup time, gpmc_wait[1:0] valid before gpmc_clk high	2.5		ns
F22	$t_h(clkH-waitV)$	Hold Time, gpmc_wait[1:0] valid after gpmc_clk high	1.9		ns

**Table 5-59. GPMC/NOR Flash Interface Switching Characteristics - Synchronous Mode - Alternate Timing with Pad Loopback Clock**

NO.	PARAMETER	DESCRIPTION	MIN	MAX	UNIT
F0	$t_{c(clk)}$	Cycle time, output clock gpmc_clk period <sup>(12)</sup>	15.04		ns
F2	$t_{d(clkH-nCSV)}$	Delay time, gpmc_clk rising edge to gpmc_cs[7:0] transition <sup>(14)</sup>	F-0.13 <sup>(6)</sup>	F+6.1 <sup>(6)</sup>	ns
F3	$t_{d(clkH-nCSIV)}$	Delay time, gpmc_clk rising edge to gpmc_cs[7:0] invalid <sup>(14)</sup>	E+0.7 <sup>(5)</sup>	E+6.1 <sup>(5)</sup>	ns
F4	$t_{d(ADDV-clk)}$	Delay time, gpmc_a[27:0] address bus valid to gpmc_clk first edge	B+0.21 <sup>(2)</sup>	B+6.1 <sup>(2)</sup>	ns
F5	$t_{d(clkH-ADDIV)}$	Delay time, gpmc_clk rising edge to gpmc_a[27:0] gpmc address bus invalid	0.7		ns
F6	$t_{d(nBEV-clk)}$	Delay time, gpmc_ben[1:0] valid to gpmc_clk rising edge	B-4.9	B+0.4	ns
F7	$t_{d(clkH-nBEIV)}$	Delay time, gpmc_clk rising edge to gpmc_ben[1:0] invalid	D-0.4	D+4.9	ns
F8	$t_{d(clkH-nADV)}$	Delay time, gpmc_clk rising edge to gpmc_advn_ale transition <sup>(14)</sup>	G+0.7 <sup>(7)</sup>	G+6.1 <sup>(7)</sup>	ns
F9	$t_{d(clkH-nADVIV)}$	Delay time, gpmc_clk rising edge to gpmc_advn_ale invalid <sup>(14)</sup>	D+0.7 <sup>(4)</sup>	D+6.1 <sup>(4)</sup>	ns
F10	$t_{d(clkH-nOE)}$	Delay time, gpmc_clk rising edge to gpmc_oen_ren transition <sup>(14)</sup>	H+0.42 <sup>(8)</sup>	H+5.1 <sup>(8)</sup>	ns
F11	$t_{d(clkH-nOEIV)}$	Delay time, gpmc_clk rising edge to gpmc_oen_ren invalid <sup>(14)</sup>	E+0.7 <sup>(5)</sup>	E+5.1 <sup>(5)</sup>	ns
F14	$t_{d(clkH-nWE)}$	Delay time, gpmc_clk rising edge to gpmc_wen transition <sup>(14)</sup>	I+0.46 <sup>(9)</sup>	I+6.1 <sup>(9)</sup>	ns
F15	$t_{d(clkH-Data)}$	Delay time, gpmc_clk rising edge to gpmc_ad[15:0] data bus transition	J-0.4 <sup>(10)</sup>	J+4.9 <sup>(10)</sup>	ns
F17	$t_{d(clkH-nBE)}$	Delay time, gpmc_clk rising edge to gpmc_ben[1:0] transition	J-0.4 <sup>(10)</sup>	J+5.63 <sup>(10)</sup>	ns
F18	$t_w(nCSV)$	Pulse duration, gpmc_cs[7:0] low	A <sup>(1)</sup>		ns
F19	$t_w(nBEV)$	Pulse duration, gpmc_ben[1:0] low	C <sup>(3)</sup>		ns
F20	$t_w(nADV)$	Pulse duration, gpmc_advn_ale low	K <sup>(11)</sup>		ns
F23	$t_{d(CLK-GPIO)}$	Delay time, gpmc_clk transition to gpio6_16 transition <sup>(13)</sup>	0.96	6.1	ns

(1) For single read:  $A = (CSRdOffTime - CSOnTime) \times (TimeParaGranularity + 1) \times GPMC\_FCLK$  period  
 For burst read:  $A = (CSRdOffTime - CSOnTime + (n - 1) \times PageBurstAccessTime) \times (TimeParaGranularity + 1) \times GPMC\_FCLK$  period  
 For burst write:  $A = (CSWrOffTime - CSOnTime + (n - 1) \times PageBurstAccessTime) \times (TimeParaGranularity + 1) \times GPMC\_FCLK$  period  
 with n the page burst access number.

(2)  $B = ClkActivationTime \times GPMC\_FCLK$

(3) For single read:  $C = RdCycleTime \times (TimeParaGranularity + 1) \times GPMC\_FCLK$   
 For burst read:  $C = (RdCycleTime + (n - 1) \times PageBurstAccessTime) \times (TimeParaGranularity + 1) \times GPMC\_FCLK$   
 For Burst write:  $C = (WrCycleTime + (n - 1) \times PageBurstAccessTime) \times (TimeParaGranularity + 1) \times GPMC\_FCLK$  with n the page burst access number.

(4) For single read:  $D = (RdCycleTime - AccessTime) \times (TimeParaGranularity + 1) \times GPMC\_FCLK$   
 For burst read:  $D = (RdCycleTime - AccessTime) \times (TimeParaGranularity + 1) \times GPMC\_FCLK$   
 For burst write:  $D = (WrCycleTime - AccessTime) \times (TimeParaGranularity + 1) \times GPMC\_FCLK$

(5) For single read:  $E = (CSRdOffTime - AccessTime) \times (TimeParaGranularity + 1) \times GPMC\_FCLK$   
 For burst read:  $E = (CSRdOffTime - AccessTime) \times (TimeParaGranularity + 1) \times GPMC\_FCLK$   
 For burst write:  $E = (CSWrOffTime - AccessTime) \times (TimeParaGranularity + 1) \times GPMC\_FCLK$

(6) For nCS falling edge (CS activated):  
 Case GpmcFCLKDivider = 0 :  
 $F = 0.5 \times CSExtraDelay \times GPMC\_FCLK$   
 Case GpmcFCLKDivider = 1:  
 $F = 0.5 \times CSExtraDelay \times GPMC\_FCLK$  if (ClkActivationTime and CSOnTime are odd) or (ClkActivationTime and CSOnTime are even)  
 $F = (1 + 0.5 \times CSExtraDelay) \times GPMC\_FCLK$  otherwise  
 Case GpmcFCLKDivider = 2:



$F = 0.5 \times \text{CSEExtraDelay} \times \text{GPMC\_FCLK}$  if  $((\text{CSOnTime} - \text{ClkActivationTime})$  is a multiple of 3)  
 $F = (1 + 0.5 \times \text{CSEExtraDelay}) \times \text{GPMC\_FCLK}$  if  $((\text{CSOnTime} - \text{ClkActivationTime} - 1)$  is a multiple of 3)  
 $F = (2 + 0.5 \times \text{CSEExtraDelay}) \times \text{GPMC\_FCLK}$  if  $((\text{CSOnTime} - \text{ClkActivationTime} - 2)$  is a multiple of 3)  
 Case GpmcFCLKDivider = 3:  
 $F = 0.5 \times \text{CSEExtraDelay} \times \text{GPMC\_FCLK}$  if  $((\text{CSOnTime} - \text{ClkActivationTime})$  is a multiple of 4)  
 $F = (1 + 0.5 \times \text{CSEExtraDelay}) \times \text{GPMC\_FCLK}$  if  $((\text{CSOnTime} - \text{ClkActivationTime} - 1)$  is a multiple of 4)  
 $F = (2 + 0.5 \times \text{CSEExtraDelay}) \times \text{GPMC\_FCLK}$  if  $((\text{CSOnTime} - \text{ClkActivationTime} - 2)$  is a multiple of 4)  
 $F = (3 + 0.5 \times \text{CSEExtraDelay}) \times \text{GPMC\_FCLK}$  if  $((\text{CSOnTime} - \text{ClkActivationTime} - 3)$  is a multiple of 4)

(7) For ADV falling edge (ADV activated):

Case GpmcFCLKDivider = 0 :  
 $G = 0.5 \times \text{ADVExtraDelay} \times \text{GPMC\_FCLK}$   
 Case GpmcFCLKDivider = 1:  
 $G = 0.5 \times \text{ADVExtraDelay} \times \text{GPMC\_FCLK}$  if (ClkActivationTime and ADVOnTime are odd) or (ClkActivationTime and ADVOnTime are even)  
 $G = (1 + 0.5 \times \text{ADVExtraDelay}) \times \text{GPMC\_FCLK}$  otherwise  
 Case GpmcFCLKDivider = 2:  
 $G = 0.5 \times \text{ADVExtraDelay} \times \text{GPMC\_FCLK}$  if  $((\text{ADVOnTime} - \text{ClkActivationTime})$  is a multiple of 3)  
 $G = (1 + 0.5 \times \text{ADVExtraDelay}) \times \text{GPMC\_FCLK}$  if  $((\text{ADVOnTime} - \text{ClkActivationTime} - 1)$  is a multiple of 3)  
 $G = (2 + 0.5 \times \text{ADVExtraDelay}) \times \text{GPMC\_FCLK}$  if  $((\text{ADVOnTime} - \text{ClkActivationTime} - 2)$  is a multiple of 3)  
 For ADV rising edge (ADV deactivated) in Reading mode:  
 Case GpmcFCLKDivider = 0:  
 $G = 0.5 \times \text{ADVExtraDelay} \times \text{GPMC\_FCLK}$   
 Case GpmcFCLKDivider = 1:  
 $G = 0.5 \times \text{ADVExtraDelay} \times \text{GPMC\_FCLK}$  if (ClkActivationTime and ADVRdOffTime are odd) or (ClkActivationTime and ADVRdOffTime are even)  
 $G = (1 + 0.5 \times \text{ADVExtraDelay}) \times \text{GPMC\_FCLK}$  otherwise  
 Case GpmcFCLKDivider = 2:  
 $G = 0.5 \times \text{ADVExtraDelay} \times \text{GPMC\_FCLK}$  if  $((\text{ADVRdOffTime} - \text{ClkActivationTime})$  is a multiple of 3)  
 $G = (1 + 0.5 \times \text{ADVExtraDelay}) \times \text{GPMC\_FCLK}$  if  $((\text{ADVRdOffTime} - \text{ClkActivationTime} - 1)$  is a multiple of 3)  
 $G = (2 + 0.5 \times \text{ADVExtraDelay}) \times \text{GPMC\_FCLK}$  if  $((\text{ADVRdOffTime} - \text{ClkActivationTime} - 2)$  is a multiple of 3)  
 Case GpmcFCLKDivider = 3:  
 $G = 0.5 \times \text{ADVExtraDelay} \times \text{GPMC\_FCLK}$  if  $((\text{ADVRdOffTime} - \text{ClkActivationTime})$  is a multiple of 4)  
 $G = (1 + 0.5 \times \text{ADVExtraDelay}) \times \text{GPMC\_FCLK}$  if  $((\text{ADVRdOffTime} - \text{ClkActivationTime} - 1)$  is a multiple of 4)  
 $G = (2 + 0.5 \times \text{ADVExtraDelay}) \times \text{GPMC\_FCLK}$  if  $((\text{ADVRdOffTime} - \text{ClkActivationTime} - 2)$  is a multiple of 4)  
 $G = (3 + 0.5 \times \text{ADVExtraDelay}) \times \text{GPMC\_FCLK}$  if  $((\text{ADVRdOffTime} - \text{ClkActivationTime} - 3)$  is a multiple of 4)  
 For ADV rising edge (ADV deactivated) in Writing mode:  
 Case GpmcFCLKDivider = 0:  
 $G = 0.5 \times \text{ADVExtraDelay} \times \text{GPMC\_FCLK}$   
 Case GpmcFCLKDivider = 1:  
 $G = 0.5 \times \text{ADVExtraDelay} \times \text{GPMC\_FCLK}$  if (ClkActivationTime and ADVWrOffTime are odd) or (ClkActivationTime and ADVWrOffTime are even)  
 $G = (1 + 0.5 \times \text{ADVExtraDelay}) \times \text{GPMC\_FCLK}$  otherwise  
 Case GpmcFCLKDivider = 2:  
 $G = 0.5 \times \text{ADVExtraDelay} \times \text{GPMC\_FCLK}$  if  $((\text{ADVWrOffTime} - \text{ClkActivationTime})$  is a multiple of 3)  
 $G = (1 + 0.5 \times \text{ADVExtraDelay}) \times \text{GPMC\_FCLK}$  if  $((\text{ADVWrOffTime} - \text{ClkActivationTime} - 1)$  is a multiple of 3)  
 $G = (2 + 0.5 \times \text{ADVExtraDelay}) \times \text{GPMC\_FCLK}$  if  $((\text{ADVWrOffTime} - \text{ClkActivationTime} - 2)$  is a multiple of 3)  
 Case GpmcFCLKDivider = 3:  
 $G = 0.5 \times \text{ADVExtraDelay} \times \text{GPMC\_FCLK}$  if  $((\text{ADVWrOffTime} - \text{ClkActivationTime})$  is a multiple of 4)  
 $G = (1 + 0.5 \times \text{ADVExtraDelay}) \times \text{GPMC\_FCLK}$  if  $((\text{ADVWrOffTime} - \text{ClkActivationTime} - 1)$  is a multiple of 4)  
 $G = (2 + 0.5 \times \text{ADVExtraDelay}) \times \text{GPMC\_FCLK}$  if  $((\text{ADVWrOffTime} - \text{ClkActivationTime} - 2)$  is a multiple of 4)  
 $G = (3 + 0.5 \times \text{ADVExtraDelay}) \times \text{GPMC\_FCLK}$  if  $((\text{ADVWrOffTime} - \text{ClkActivationTime} - 3)$  is a multiple of 4)

(8) For OE falling edge (OE activated):

Case GpmcFCLKDivider = 0:  
 $H = 0.5 \times \text{OEEExtraDelay} \times \text{GPMC\_FCLK}$   
 Case GpmcFCLKDivider = 1:  
 $H = 0.5 \times \text{OEEExtraDelay} \times \text{GPMC\_FCLK}$  if (ClkActivationTime and OEOnTime are odd) or (ClkActivationTime and OEOnTime are even)  
 $H = (1 + 0.5 \times \text{OEEExtraDelay}) \times \text{GPMC\_FCLK}$  otherwise  
 Case GpmcFCLKDivider = 2:  
 $H = 0.5 \times \text{OEEExtraDelay} \times \text{GPMC\_FCLK}$  if  $((\text{OEOnTime} - \text{ClkActivationTime})$  is a multiple of 3)  
 $H = (1 + 0.5 \times \text{OEEExtraDelay}) \times \text{GPMC\_FCLK}$  if  $((\text{OEOnTime} - \text{ClkActivationTime} - 1)$  is a multiple of 3)  
 $H = (2 + 0.5 \times \text{OEEExtraDelay}) \times \text{GPMC\_FCLK}$  if  $((\text{OEOnTime} - \text{ClkActivationTime} - 2)$  is a multiple of 3)  
 Case GpmcFCLKDivider = 3:  
 $H = 0.5 \times \text{OEEExtraDelay} \times \text{GPMC\_FCLK}$  if  $((\text{OEOnTime} - \text{ClkActivationTime})$  is a multiple of 4)  
 $H = (1 + 0.5 \times \text{OEEExtraDelay}) \times \text{GPMC\_FCLK}$  if  $((\text{OEOnTime} - \text{ClkActivationTime} - 1)$  is a multiple of 4)  
 $H = (2 + 0.5 \times \text{OEEExtraDelay}) \times \text{GPMC\_FCLK}$  if  $((\text{OEOnTime} - \text{ClkActivationTime} - 2)$  is a multiple of 4)  
 $H = (3 + 0.5 \times \text{OEEExtraDelay}) \times \text{GPMC\_FCLK}$  if  $((\text{OEOnTime} - \text{ClkActivationTime} - 3)$  is a multiple of 4)  
 For OE rising edge (OE deactivated):  
 Case GpmcFCLKDivider = 0:  
 $H = 0.5 \times \text{OEEExtraDelay} \times \text{GPMC\_FCLK}$   
 Case GpmcFCLKDivider = 1:  
 $H = 0.5 \times \text{OEEExtraDelay} \times \text{GPMC\_FCLK}$  if (ClkActivationTime and OEOffTime are odd) or (ClkActivationTime and OEOffTime are even)

- even)
- $H = (1 + 0.5 \times \text{OEExtraDelay}) \times \text{GPMC\_FCLK}$  otherwise
  - Case GpmcFCLKDivider = 2:
    - $H = 0.5 \times \text{OEExtraDelay} \times \text{GPMC\_FCLK}$  if  $((\text{OEOffTime} - \text{ClkActivationTime})$  is a multiple of 3)
    - $H = (1 + 0.5 \times \text{OEExtraDelay}) \times \text{GPMC\_FCLK}$  if  $((\text{OEOffTime} - \text{ClkActivationTime} - 1)$  is a multiple of 3)
    - $H = (2 + 0.5 \times \text{OEExtraDelay}) \times \text{GPMC\_FCLK}$  if  $((\text{OEOffTime} - \text{ClkActivationTime} - 2)$  is a multiple of 3)
  - Case GpmcFCLKDivider = 3:
    - $H = 0.5 \times \text{OEExtraDelay} \times \text{GPMC\_FCLK}$  if  $((\text{OEOffTime} - \text{ClkActivationTime})$  is a multiple of 4)
    - $H = (1 + 0.5 \times \text{OEExtraDelay}) \times \text{GPMC\_FCLK}$  if  $((\text{OEOffTime} - \text{ClkActivationTime} - 1)$  is a multiple of 4)
    - $H = (2 + 0.5 \times \text{OEExtraDelay}) \times \text{GPMC\_FCLK}$  if  $((\text{OEOffTime} - \text{ClkActivationTime} - 2)$  is a multiple of 4)
    - $H = (3 + 0.5 \times \text{OEExtraDelay}) \times \text{GPMC\_FCLK}$  if  $((\text{OEOffTime} - \text{ClkActivationTime} - 3)$  is a multiple of 4)
- (9) For WE falling edge (WE activated):
- Case GpmcFCLKDivider = 0:
    - $I = 0.5 \times \text{WEExtraDelay} \times \text{GPMC\_FCLK}$
  - Case GpmcFCLKDivider = 1:
    - $I = 0.5 \times \text{WEExtraDelay} \times \text{GPMC\_FCLK}$  if  $(\text{ClkActivationTime}$  and  $\text{WEOnTime}$  are odd) or  $(\text{ClkActivationTime}$  and  $\text{WEOnTime}$  are even)
    - $I = (1 + 0.5 \times \text{WEExtraDelay}) \times \text{GPMC\_FCLK}$  otherwise
  - Case GpmcFCLKDivider = 2:
    - $I = 0.5 \times \text{WEExtraDelay} \times \text{GPMC\_FCLK}$  if  $((\text{WEOnTime} - \text{ClkActivationTime})$  is a multiple of 3)
    - $I = (1 + 0.5 \times \text{WEExtraDelay}) \times \text{GPMC\_FCLK}$  if  $((\text{WEOnTime} - \text{ClkActivationTime} - 1)$  is a multiple of 3)
    - $I = (2 + 0.5 \times \text{WEExtraDelay}) \times \text{GPMC\_FCLK}$  if  $((\text{WEOnTime} - \text{ClkActivationTime} - 2)$  is a multiple of 3)
  - Case GpmcFCLKDivider = 3:
    - $I = 0.5 \times \text{WEExtraDelay} \times \text{GPMC\_FCLK}$  if  $((\text{WEOnTime} - \text{ClkActivationTime})$  is a multiple of 4)
    - $I = (1 + 0.5 \times \text{WEExtraDelay}) \times \text{GPMC\_FCLK}$  if  $((\text{WEOnTime} - \text{ClkActivationTime} - 1)$  is a multiple of 4)
    - $I = (2 + 0.5 \times \text{WEExtraDelay}) \times \text{GPMC\_FCLK}$  if  $((\text{WEOnTime} - \text{ClkActivationTime} - 2)$  is a multiple of 4)
    - $I = (3 + 0.5 \times \text{WEExtraDelay}) \times \text{GPMC\_FCLK}$  if  $((\text{WEOnTime} - \text{ClkActivationTime} - 3)$  is a multiple of 4)
- For WE rising edge (WE deactivated):
- Case GpmcFCLKDivider = 0:
    - $I = 0.5 \times \text{WEExtraDelay} \times \text{GPMC\_FCLK}$
  - Case GpmcFCLKDivider = 1:
    - $I = 0.5 \times \text{WEExtraDelay} \times \text{GPMC\_FCLK}$  if  $(\text{ClkActivationTime}$  and  $\text{WEOffTime}$  are odd) or  $(\text{ClkActivationTime}$  and  $\text{WEOffTime}$  are even)
    - $I = (1 + 0.5 \times \text{WEExtraDelay}) \times \text{GPMC\_FCLK}$  otherwise
  - Case GpmcFCLKDivider = 2:
    - $I = 0.5 \times \text{WEExtraDelay} \times \text{GPMC\_FCLK}$  if  $((\text{WEOffTime} - \text{ClkActivationTime})$  is a multiple of 3)
    - $I = (1 + 0.5 \times \text{WEExtraDelay}) \times \text{GPMC\_FCLK}$  if  $((\text{WEOffTime} - \text{ClkActivationTime} - 1)$  is a multiple of 3)
    - $I = (2 + 0.5 \times \text{WEExtraDelay}) \times \text{GPMC\_FCLK}$  if  $((\text{WEOffTime} - \text{ClkActivationTime} - 2)$  is a multiple of 3)
  - Case GpmcFCLKDivider = 3:
    - $I = 0.5 \times \text{WEExtraDelay} \times \text{GPMC\_FCLK}$  if  $((\text{WEOffTime} - \text{ClkActivationTime})$  is a multiple of 4)
    - $I = (1 + 0.5 \times \text{WEExtraDelay}) \times \text{GPMC\_FCLK}$  if  $((\text{WEOffTime} - \text{ClkActivationTime} - 1)$  is a multiple of 4)
    - $I = (2 + 0.5 \times \text{WEExtraDelay}) \times \text{GPMC\_FCLK}$  if  $((\text{WEOffTime} - \text{ClkActivationTime} - 2)$  is a multiple of 4)
    - $I = (3 + 0.5 \times \text{WEExtraDelay}) \times \text{GPMC\_FCLK}$  if  $((\text{WEOffTime} - \text{ClkActivationTime} - 3)$  is a multiple of 4)
- (10)  $J = \text{GPMC\_FCLK}$  period, where GPMC\_FCLK is the General-Purpose Memory Controller internal functional clock
- (11) For read:  
 $K = (\text{ADVrdOffTime} - \text{ADVrdOnTime}) \times (\text{TimeParaGranularity} + 1) \times \text{GPMC\_FCLK}$   
 For write:  $K = (\text{ADVwrOffTime} - \text{ADVwrOnTime}) \times (\text{TimeParaGranularity} + 1) \times \text{GPMC\_FCLK}$
- (12) The gpmc\_clk output clock maximum and minimum frequency is programmable in the I/F module by setting the GPMC\_CONFIG1\_CSx configuration register bit fields GpmcFCLKDivider
- (13) gpio6\_16 programmed to MUXMODE=9 (clkout1), CM\_CLKSEL\_CLKOUTMUX1 programmed to 7 (CORE\_DPLL\_OUT\_DCLK), CM\_CLKSEL\_CORE\_DPLL\_OUT\_CLK\_CLKOUTMUX programmed to 1.
- (14) CSEXTRADelay = 0, ADVEXTRADelay = 0, WEEXTRADelay = 0, OEEXTRADelay = 0. Extra half-GPMC\_FCLK cycle delay mode is not timed.

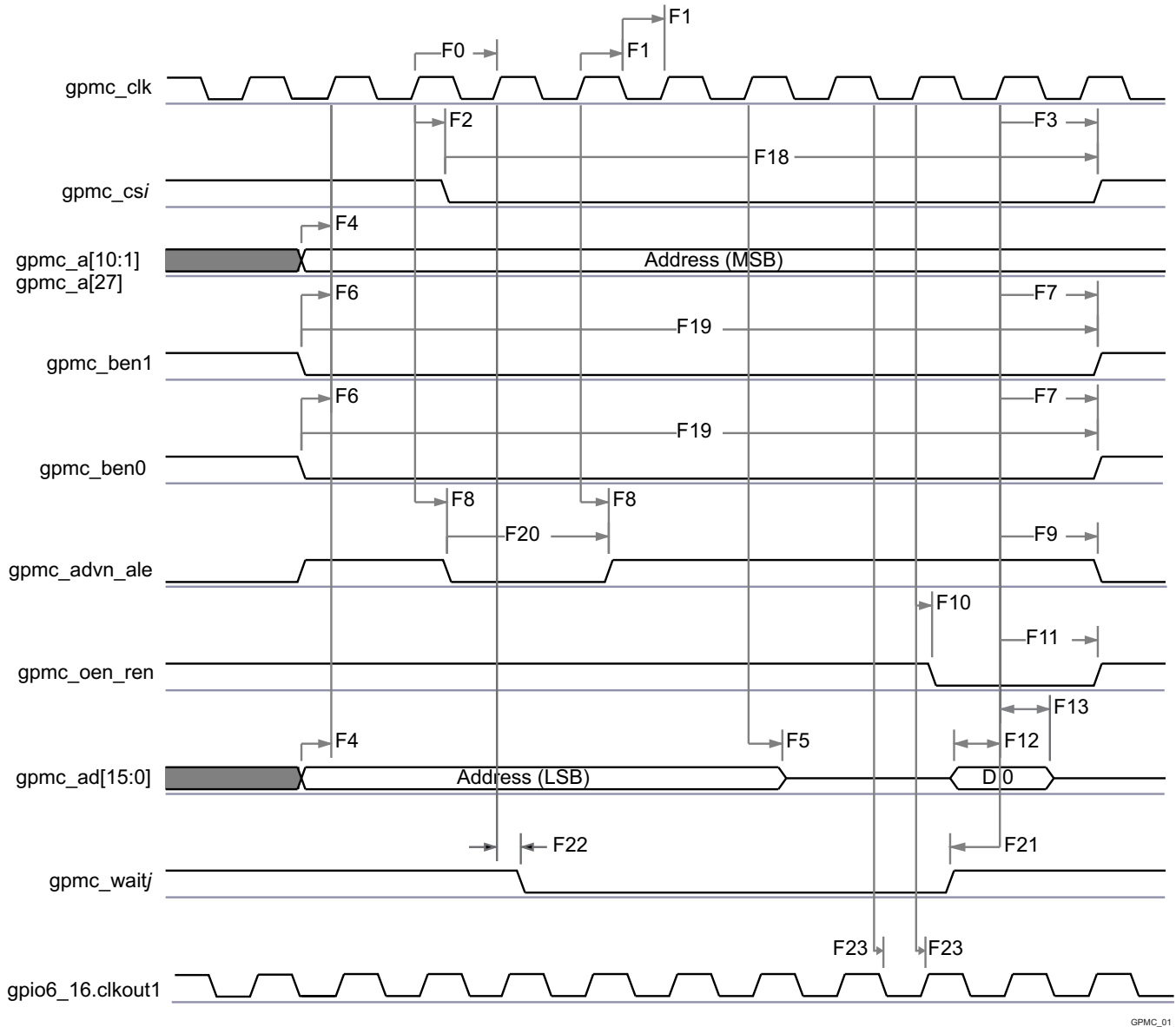

Figure 5-24. GPMC / Multiplexed 16bits NOR Flash - Synchronous Single Read - (GpmcFCLKDivider = 0)<sup>(1)(2)</sup>

(1) In gpmc\_csi, i = 0 to 7.

(2) In gpmc\_waitj, j = 0 to 1.

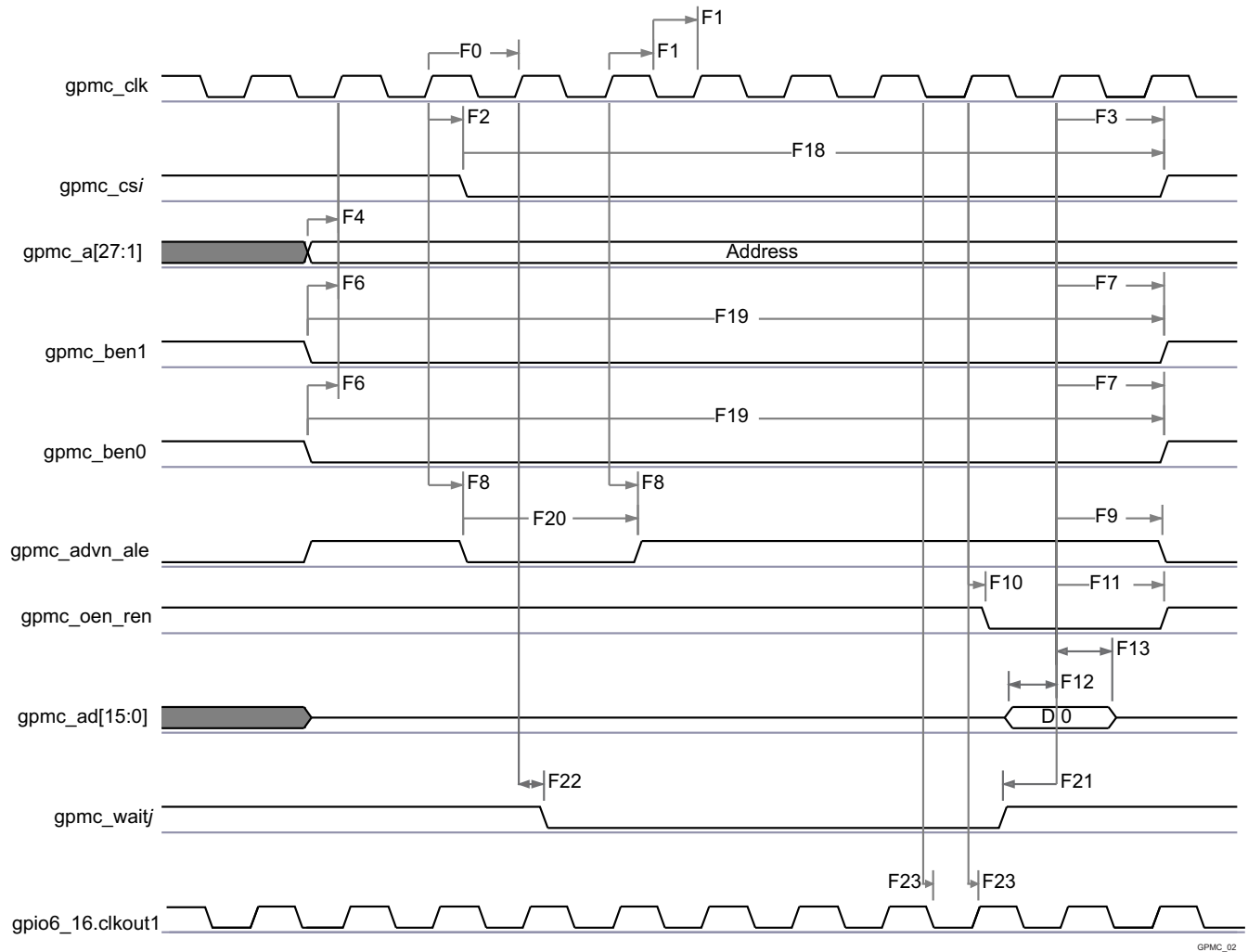
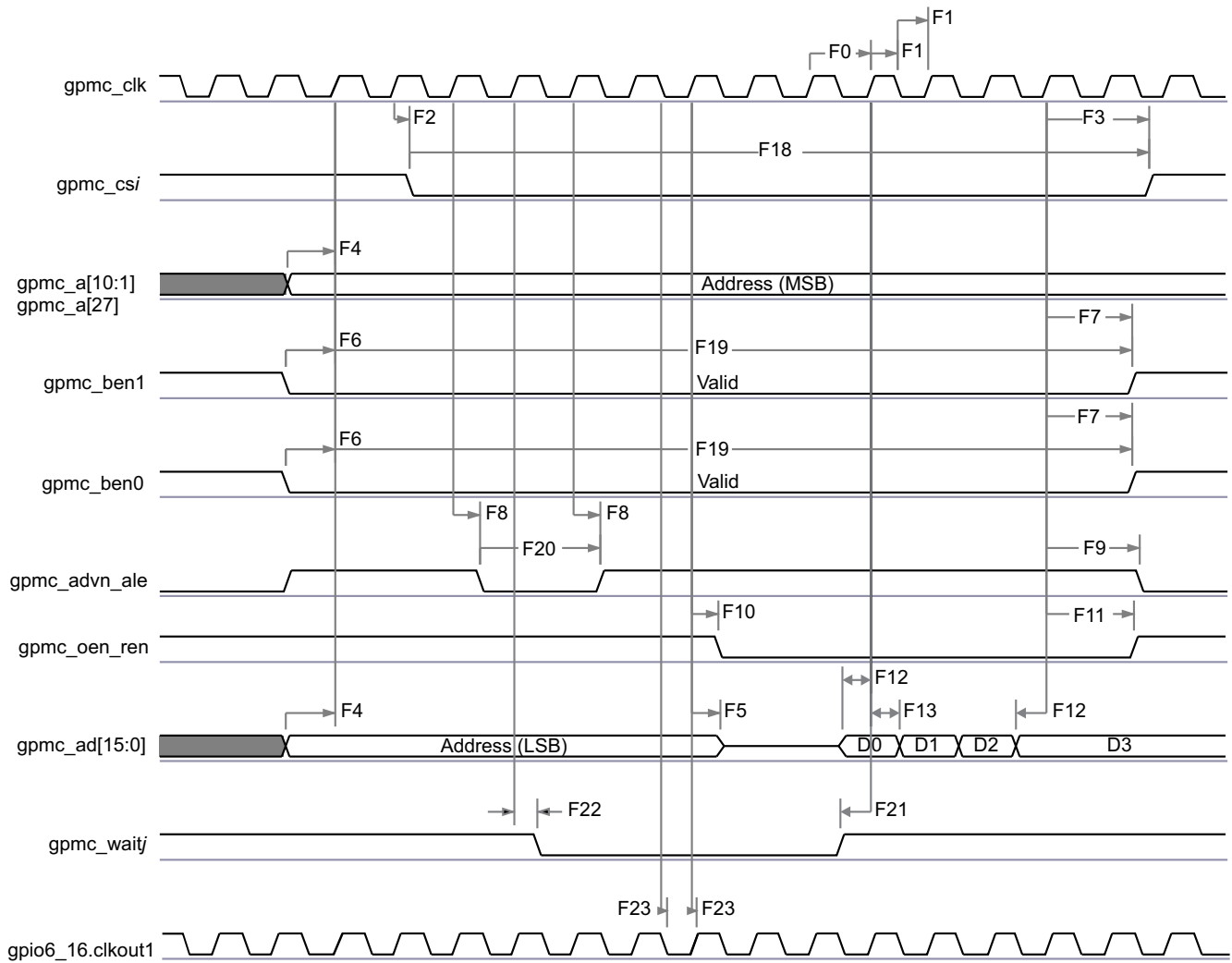

Figure 5-25. GPMC / Nonmultiplexed 16bits NOR Flash - Synchronous Single Read - (GpmcFCLKDivider = 0)<sup>(1)(2)</sup>

- (1) In gpmc\_csi, i = 0 to 7.
- (2) In gpmc\_waitj, j = 0 to 1.



GPMC\_03

**Figure 5-26. GPMC / Multiplexed 16bits NOR Flash - Synchronous Burst Read 4x16 bits - (GpmcFCLKDivider = 0)<sup>(1)(2)</sup>**

- (1) In gpmc\_csi, i= 0 to 7.
- (2) In gpmc\_waitj, j = 0 to 1.

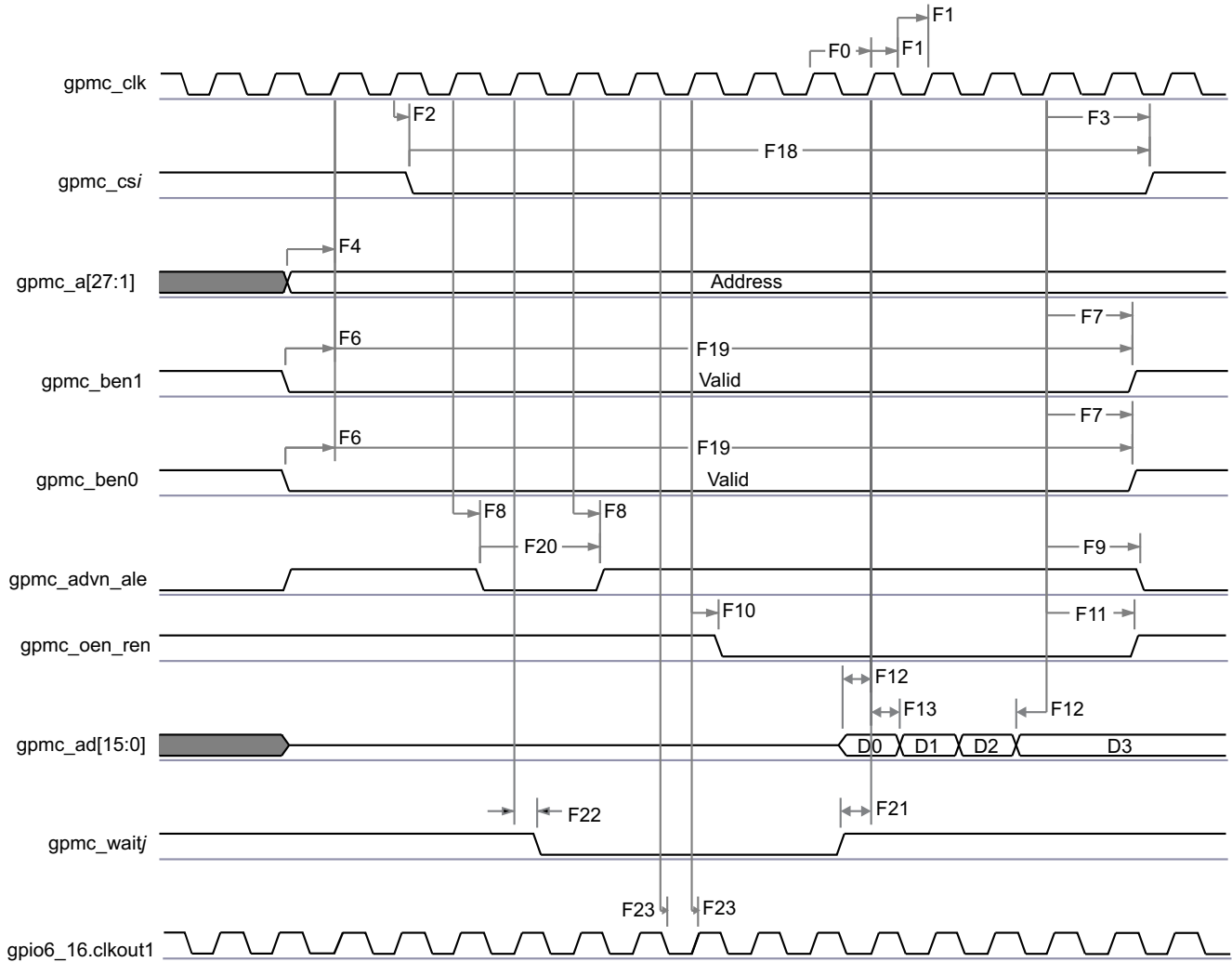

GPMC\_04

**Figure 5-27. GPMC / Nonmultiplexed 16bits NOR Flash - Synchronous Burst Read 4x16 bits - (GpmcFCLKDivider = 0)<sup>(1)(2)</sup>**

- (1) In gpmc\_csi, i = 0 to 7.
- (2) In gpmc\_waitj, j = 0 to 1.

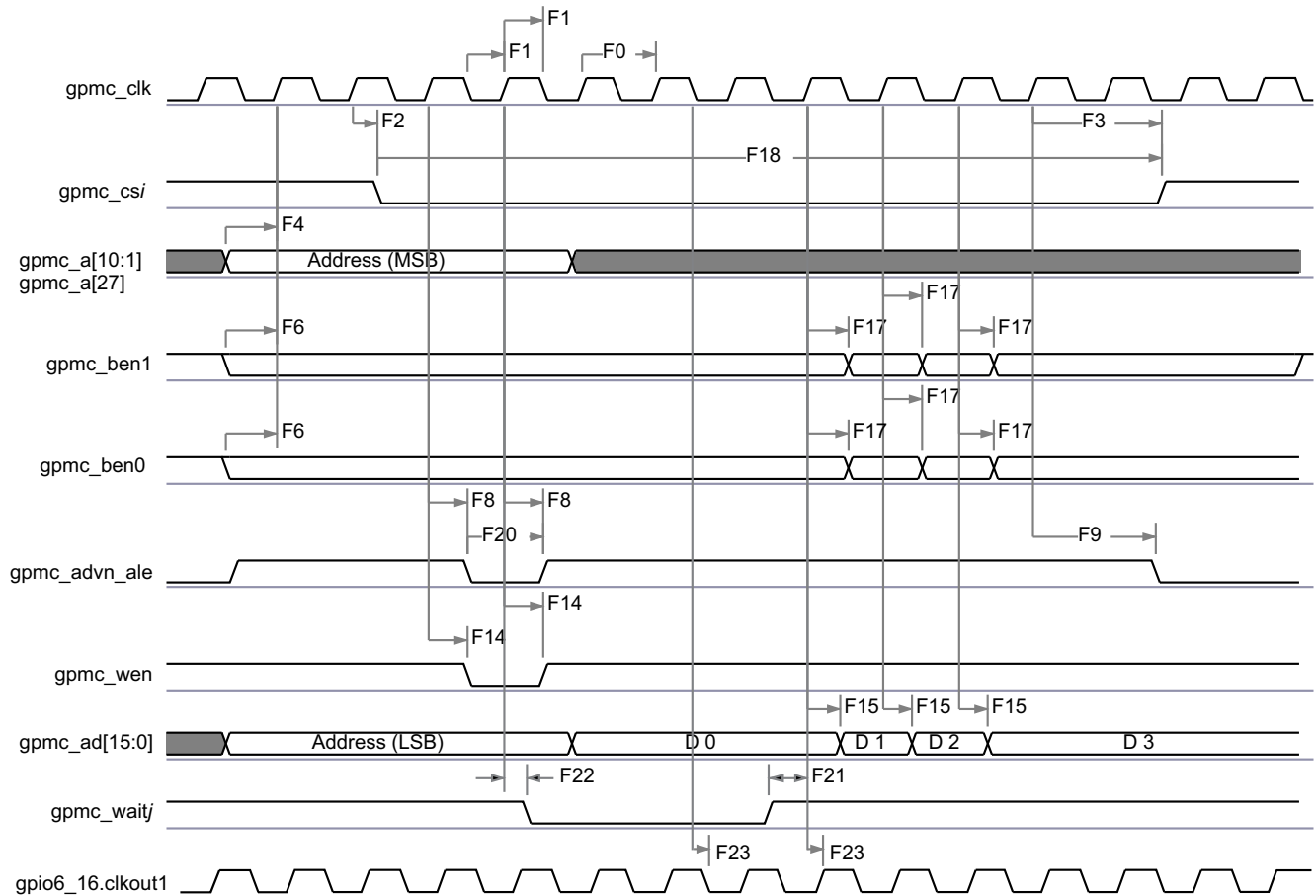

GPMC\_05

**Figure 5-28. GPMC / Multiplexed 16bits NOR Flash - Synchronous Burst Write 4x16bits - (GpmcFCLKDivider = 0)<sup>(1)(2)</sup>**

- (1) In gpmc\_csi, i = 0 to 7.
- (2) In gpmc\_waitj, j = 0 to 1.

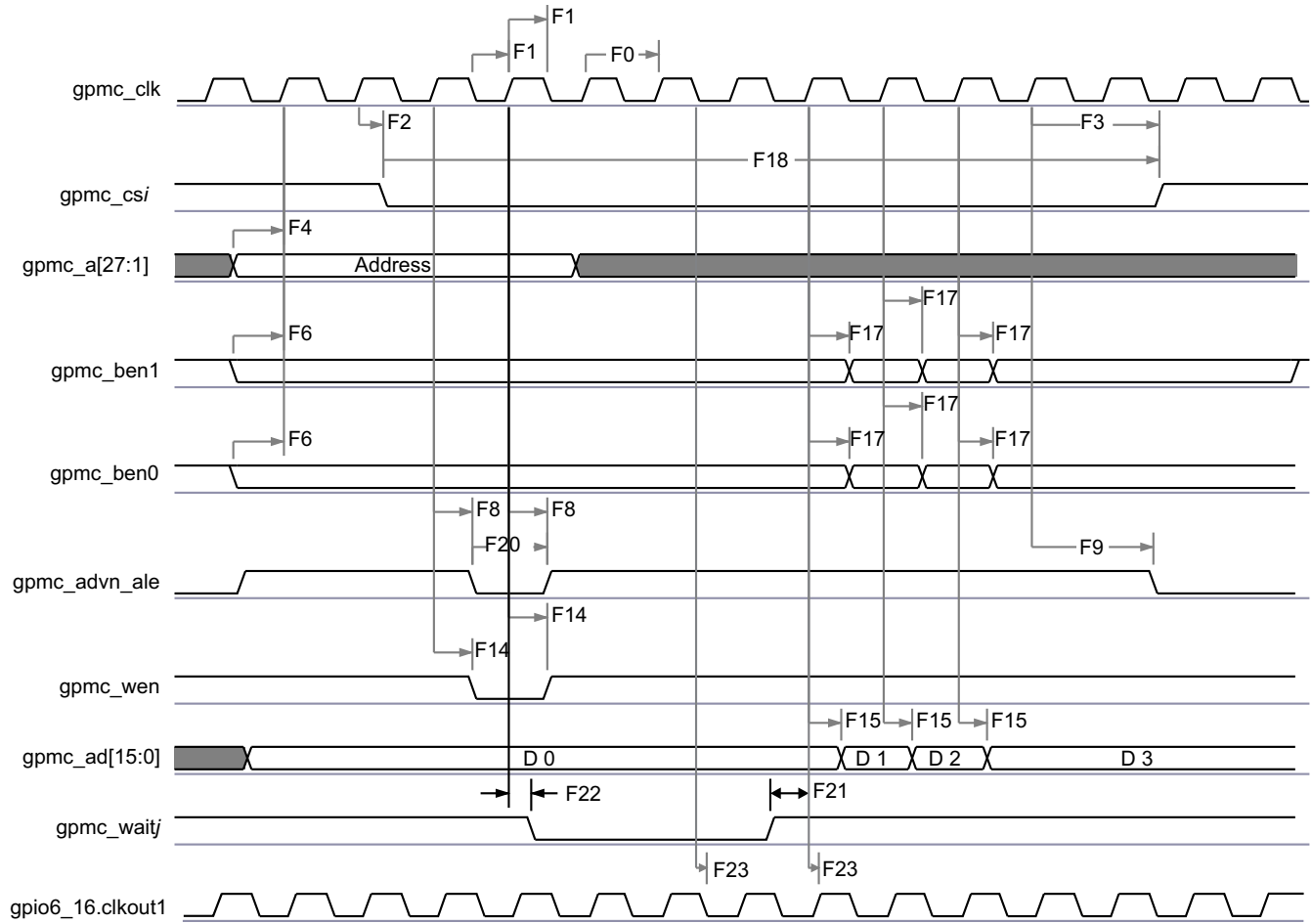

GPMC\_06

**Figure 5-29. GPMC / Nonmultiplexed 16bits NOR Flash - Synchronous Burst Write 4x16bits - (GpmcFCLKDivider = 0)<sup>(1)(2)</sup>**

- (1) In gpmc\_csi, i = 1 to 7.
- (2) In gpmc\_waitj, j = 0 to 1.

**5.10.6.7.2 GPMC/NOR Flash Interface Asynchronous Timing**

**CAUTION**

The IO Timings provided in this section are only valid for some GPMC usage modes when the corresponding Virtual IO Timings or Manual IO Timings are configured as described in the tables found in this section.

Table 5-60 and Table 5-61 assume testing over the recommended operating conditions and electrical characteristic conditions below (see Figure 5-30, Figure 5-31, Figure 5-32, Figure 5-33, Figure 5-34, and Figure 5-35).

**Table 5-60. GPMC/NOR Flash Interface Timing Requirements - Asynchronous Mode**

NO.	PARAMETER	DESCRIPTION	MIN	MAX	UNIT
FA5	t <sub>acc(DAT)</sub>	Data Maximum Access Time (GPMC_FCLK cycles)		H <sup>(1)</sup>	cycles



**Table 5-60. GPMC/NOR Flash Interface Timing Requirements - Asynchronous Mode (continued)**

NO.	PARAMETER	DESCRIPTION	MIN	MAX	UNIT
FA20	$t_{acc1-pgmode}(DAT)$	Page Mode Successive Data Maximum Access Time (GPMC_FCLK cycles)		P <sup>(2)</sup>	cycles
FA21	$t_{acc2-pgmode}(DAT)$	Page Mode First Data Maximum Access Time (GPMC_FCLK cycles)		H <sup>(1)</sup>	cycles
-	$t_{su}(DV-OEH)$	Setup time, read gpmc_ad[15:0] valid before gpmc_oen_ren high	1.9		ns
-	$t_h(OEH-DV)$	Hold time, read gpmc_ad[15:0] valid after gpmc_oen_ren high	1		ns

(1) H = Access Time × (TimeParaGranularity + 1)

(2) P = PageBurstAccessTime × (TimeParaGranularity + 1)

**Table 5-61. GPMC/NOR Flash Interface Switching Characteristics - Asynchronous Mode**

NO.	PARAMETER	DESCRIPTION	MIN	MAX	UNIT
FA0	$t_w(nBEV)$	Pulse duration, gpmc_ben[1:0] valid time		N <sup>(1)</sup>	ns
FA1	$t_w(nCSV)$	Pulse duration, gpmc_cs[7:0] low		A <sup>(2)</sup>	ns
FA3	$t_d(nCSV-nADVIV)$	Delay time, gpmc_cs[7:0] valid to gpmc_advn_ale invalid	B - 2 <sup>(3)</sup>	B + 4 <sup>(3)</sup>	ns
FA4	$t_d(nCSV-nOEIV)$	Delay time, gpmc_cs[7:0] valid to gpmc_oen_ren invalid (Single read)	C - 2 <sup>(4)</sup>	C + 4 <sup>(4)</sup>	ns
FA9	$t_d(AV-nCSV)$	Delay time, address bus valid to gpmc_cs[7:0] valid	J - 2 <sup>(5)</sup>	J + 4 <sup>(5)</sup>	ns
FA10	$t_d(nBEV-nCSV)$	Delay time, gpmc_ben[1:0] valid to gpmc_cs[7:0] valid	J - 2 <sup>(5)</sup>	J + 4 <sup>(5)</sup>	ns
FA12	$t_d(nCSV-nADVIV)$	Delay time, gpmc_cs[7:0] valid to gpmc_advn_ale valid	K - 2 <sup>(6)</sup>	K + 4 <sup>(6)</sup>	ns
FA13	$t_d(nCSV-nOEIV)$	Delay time, gpmc_cs[7:0] valid to gpmc_oen_ren valid	L - 2 <sup>(7)</sup>	L + 4 <sup>(7)</sup>	ns
FA16	$t_w(AIV)$	Pulse duration, address invalid between 2 successive R/W accesses	G <sup>(8)</sup>		ns
FA18	$t_d(nCSV-nOEIV)$	Delay time, gpmc_cs[7:0] valid to gpmc_oen_ren invalid (Burst read)	I - 2 <sup>(9)</sup>	I + 4 <sup>(9)</sup>	ns
FA20	$t_w(AV)$	Pulse duration, address valid: 2nd, 3rd and 4th accesses	D <sup>(10)</sup>		ns
FA25	$t_d(nCSV-nWEV)$	Delay time, gpmc_cs[7:0] valid to gpmc_wen valid	E - 2 <sup>(11)</sup>	E + 4 <sup>(11)</sup>	ns
FA27	$t_d(nCSV-nWEIV)$	Delay time, gpmc_cs[7:0] valid to gpmc_wen invalid	F - 2 <sup>(12)</sup>	F + 4 <sup>(12)</sup>	ns
FA28	$t_d(nWEV-DV)$	Delay time, gpmc_wen valid to data bus valid		2	ns
FA29	$t_d(DV-nCSV)$	Delay time, data bus valid to gpmc_cs[7:0] valid	J - 2 <sup>(5)</sup>	J + 4 <sup>(5)</sup>	ns
FA37	$t_d(nOEIV-AIV)$	Delay time, gpmc_oen_ren valid to gpmc_ad[15:0] multiplexed address bus phase end		2	ns

(1) For single read:  $N = RdCycleTime \times (TimeParaGranularity + 1) \times GPMC\_FCLK$   
 For single write:  $N = WrCycleTime \times (TimeParaGranularity + 1) \times GPMC\_FCLK$   
 For burst read:  $N = (RdCycleTime + (n - 1) \times PageBurstAccessTime) \times (TimeParaGranularity + 1) \times GPMC\_FCLK$   
 For burst write:  $N = (WrCycleTime + (n - 1) \times PageBurstAccessTime) \times (TimeParaGranularity + 1) \times GPMC\_FCLK$

(2) For single read:  $A = (CSRdOffTime - CSOnTime) \times (TimeParaGranularity + 1) \times GPMC\_FCLK$   
 For single write:  $A = (CSWrOffTime - CSOnTime) \times (TimeParaGranularity + 1) \times GPMC\_FCLK$   
 For burst read:  $A = (CSRdOffTime - CSOnTime + (n - 1) \times PageBurstAccessTime) \times (TimeParaGranularity + 1) \times GPMC\_FCLK$   
 For burst write:  $A = (CSWrOffTime - CSOnTime + (n - 1) \times PageBurstAccessTime) \times (TimeParaGranularity + 1) \times GPMC\_FCLK$

(3) For reading:  $B = ((ADVrdOffTime - CSOnTime) \times (TimeParaGranularity + 1) + 0.5 \times (ADVExtraDelay - CSEExtraDelay)) \times GPMC\_FCLK$   
 For writing:  $B = ((ADVwrOffTime - CSOnTime) \times (TimeParaGranularity + 1) + 0.5 \times (ADVExtraDelay - CSEExtraDelay)) \times GPMC\_FCLK$

(4)  $C = ((OEOffTime - CSOnTime) \times (TimeParaGranularity + 1) + 0.5 \times (OEEExtraDelay - CSEExtraDelay)) \times GPMC\_FCLK$

(5)  $J = (CSOnTime \times (TimeParaGranularity + 1) + 0.5 \times CSEExtraDelay) \times GPMC\_FCLK$

(6)  $K = ((ADVOnTime - CSOnTime) \times (TimeParaGranularity + 1) + 0.5 \times (ADVExtraDelay - CSEExtraDelay)) \times GPMC\_FCLK$

(7)  $L = ((OEOnTime - CSOnTime) \times (TimeParaGranularity + 1) + 0.5 \times (OEEExtraDelay - CSEExtraDelay)) \times GPMC\_FCLK$

(8)  $G = Cycle2CycleDelay \times GPMC\_FCLK \times (TimeParaGranularity + 1)$

(9)  $I = ((OEOffTime + (n - 1) \times PageBurstAccessTime - CSOnTime) \times (TimeParaGranularity + 1) + 0.5 \times (OEEExtraDelay - CSEExtraDelay)) \times GPMC\_FCLK$

(10)  $D = PageBurstAccessTime \times (TimeParaGranularity + 1) \times GPMC\_FCLK$

(11)  $E = ((WEOnTime - CSOnTime) \times (TimeParaGranularity + 1) + 0.5 \times (WEEExtraDelay - CSEExtraDelay)) \times GPMC\_FCLK$

(12)  $F = ((WEOffTime - CSOnTime) \times (TimeParaGranularity + 1) + 0.5 \times (WEEExtraDelay - CSEExtraDelay)) \times GPMC\_FCLK$

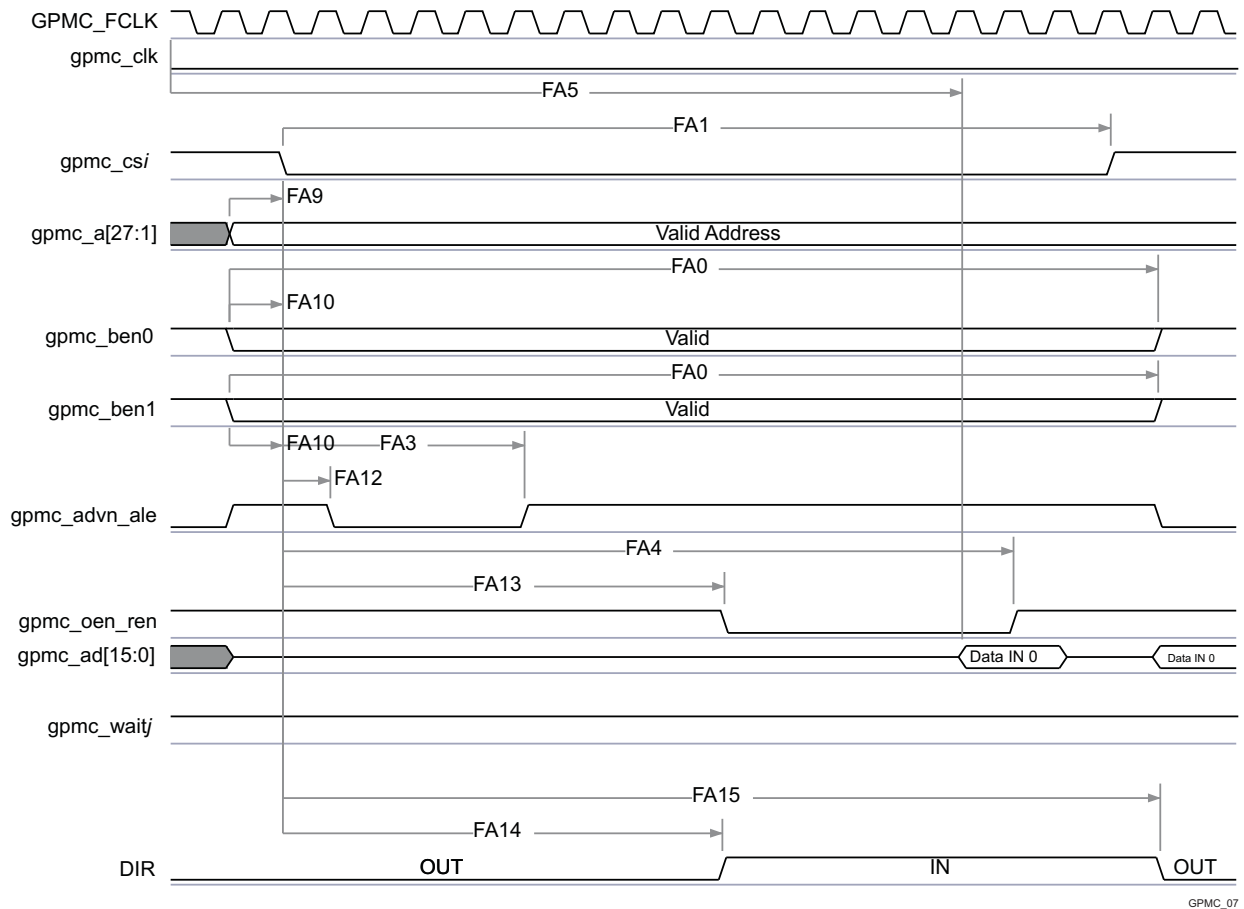

**Figure 5-30. GPMC / NOR Flash - Asynchronous Read - Single Word Timing<sup>(1)(2)(3)</sup>**

- (1) In gpmc\_csi, i = 0 to 7. In gpmc\_waitj, j = 0 to 1.
- (2) FA5 parameter illustrates amount of time required to internally sample input data. It is expressed in number of GPMC functional clock cycles. From start of read cycle and after FA5 functional clock cycles, input Data will be internally sampled by active functional clock edge. FA5 value must be stored inside AccessTime register bits field.
- (3) GPMC\_FCLK is an internal clock (GPMC functional clock) not provided externally.
- (4) The "DIR" (direction control) output signal is NOT pinned out on any of the device pads. It is an internal signal only representing a signal direction on the GPMC data bus.

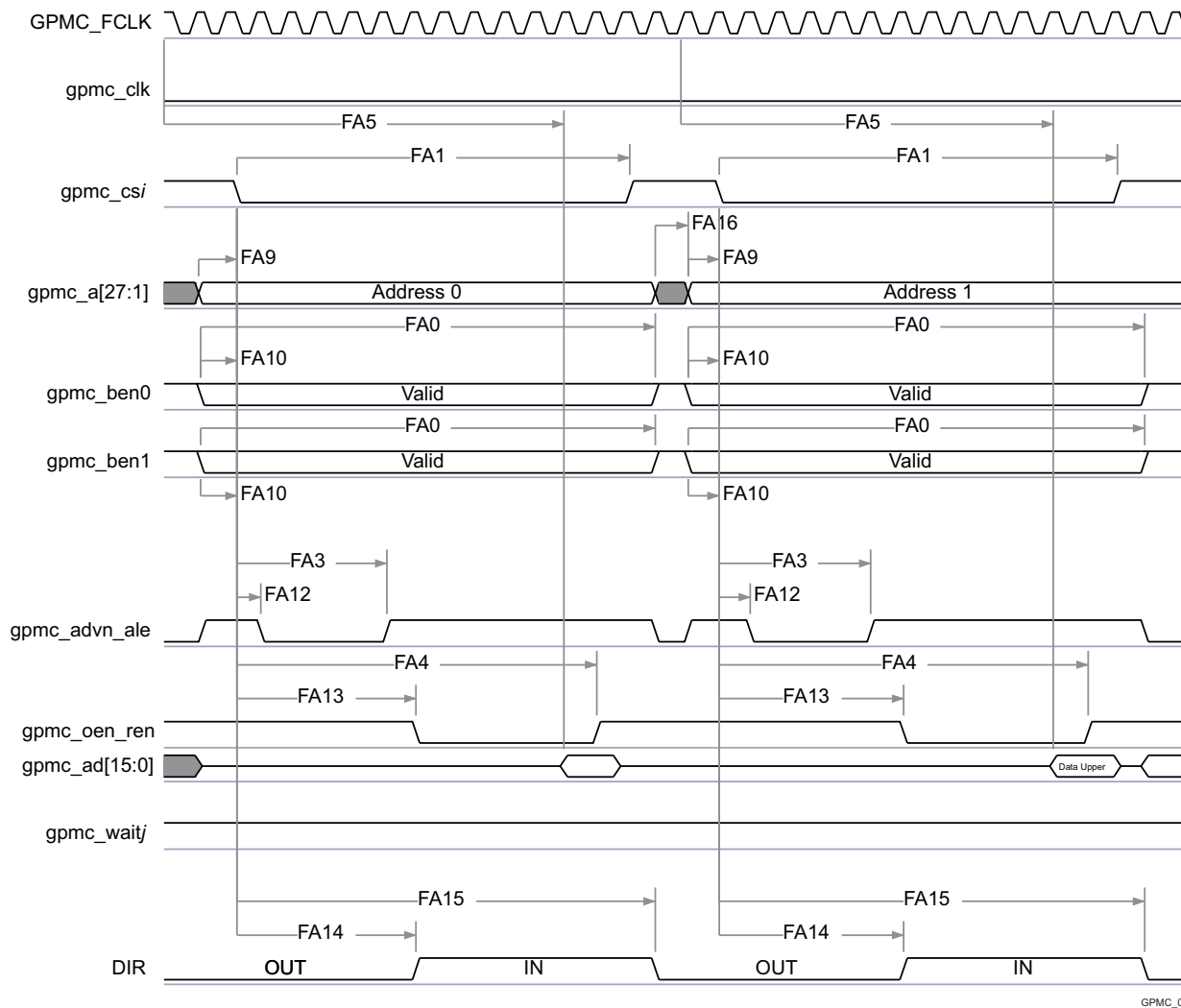

**Figure 5-31. GPMC / NOR Flash - Asynchronous Read - 32-bit Timing<sup>(1)(2)(3)</sup>**

- (1) In gpmc\_csi, i = 0 to 7. In gpmc\_waitj, j = 0 to 1.
- (2) FA5 parameter illustrates amount of time required to internally sample input Data. It is expressed in number of GPMC functional clock cycles. From start of read cycle and after FA5 functional clock cycles, input Data will be internally sampled by active functional clock edge. FA5 value should be stored inside AccessTime register bits field.
- (3) GPMC\_FCLK is an internal clock (GPMC functional clock) not provided externally.
- (4) The "DIR" (direction control) output signal is NOT pinned out on any of the device pads. It is an internal signal only representing a signal direction on the GPMC data bus.

GPMC\_08

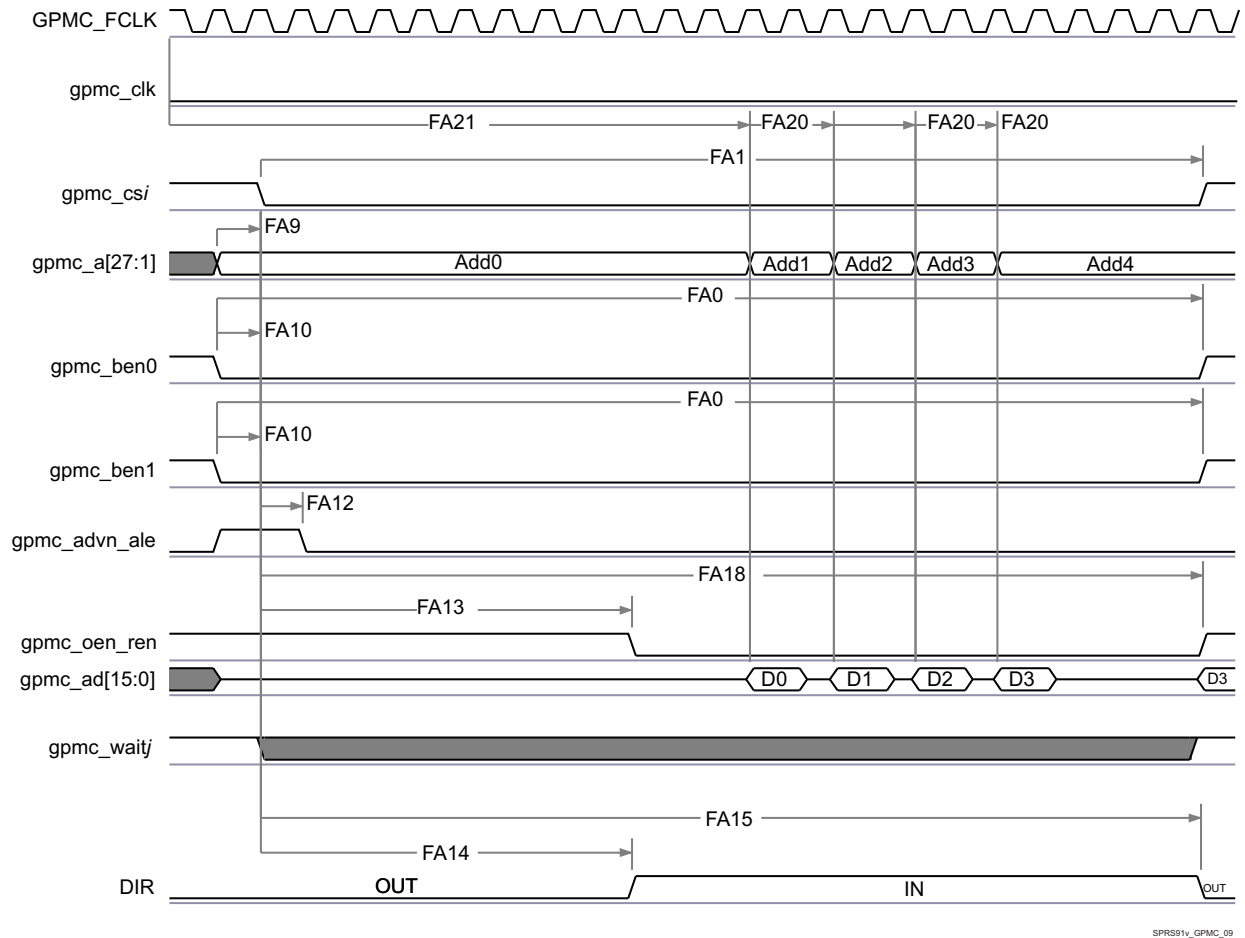

**Figure 5-32. GPMC / NOR Flash - Asynchronous Read - Page Mode 4x16-bit Timing** (1)(2)(3)(4)(5)

- (1) In  $gpmc\_csi$ ,  $i = 0$  to 7. In  $gpmc\_waitj$ ,  $j = 0$  to 1.
- (2) FA21 parameter illustrates amount of time required to internally sample first input Page Data. It is expressed in number of GPMC functional clock cycles. From start of read cycle and after FA21 functional clock cycles, First input Page Data will be internally sampled by active functional clock edge. FA21 calculation is detailed in a separated application note and should be stored inside AccessTime register bits field.
- (3) FA20 parameter illustrates amount of time required to internally sample successive input Page Data. It is expressed in number of GPMC functional clock cycles. After each access to input Page Data, next input Page Data will be internally sampled by active functional clock edge after FA20 functional clock cycles. FA20 is also the duration of address phases for successive input Page Data (excluding first input Page Data). FA20 value should be stored in PageBurstAccessTime register bits field.
- (4) GPMC\_FCLK is an internal clock (GPMC functional clock) not provided externally.
- (5) The "DIR" (direction control) output signal is NOT pinned out on any of the device pads. It is an internal signal only representing a signal direction on the GPMC data bus.

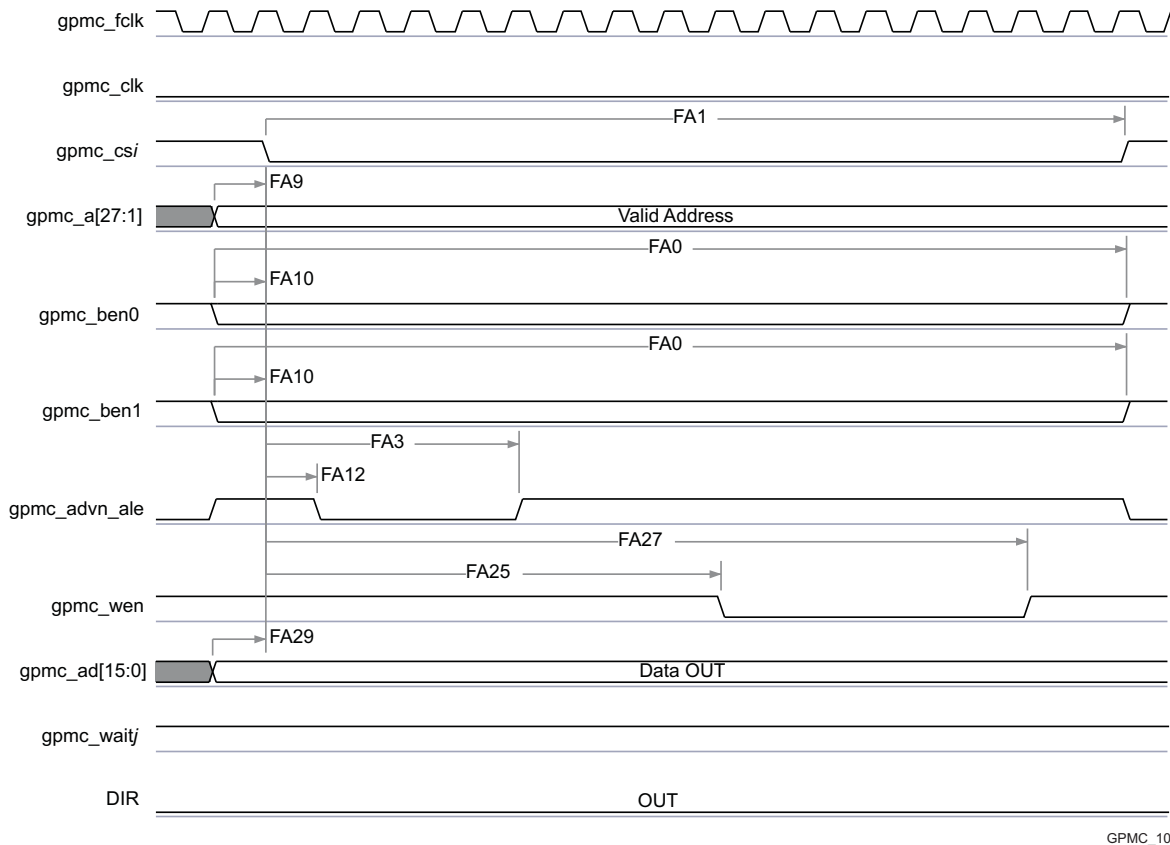

**Figure 5-33. GPMC / NOR Flash - Asynchronous Write - Single Word Timing<sup>(1)(2)</sup>**

- (1) In  $gpmc\_csi$ ,  $i = 0$  to 7. In  $gpmc\_waitj$ ,  $j = 0$  to 1.
- (2) The "DIR" (direction control) output signal is NOT pinned out on any of the device pads. It is an internal signal only representing a signal direction on the GPMC data bus.

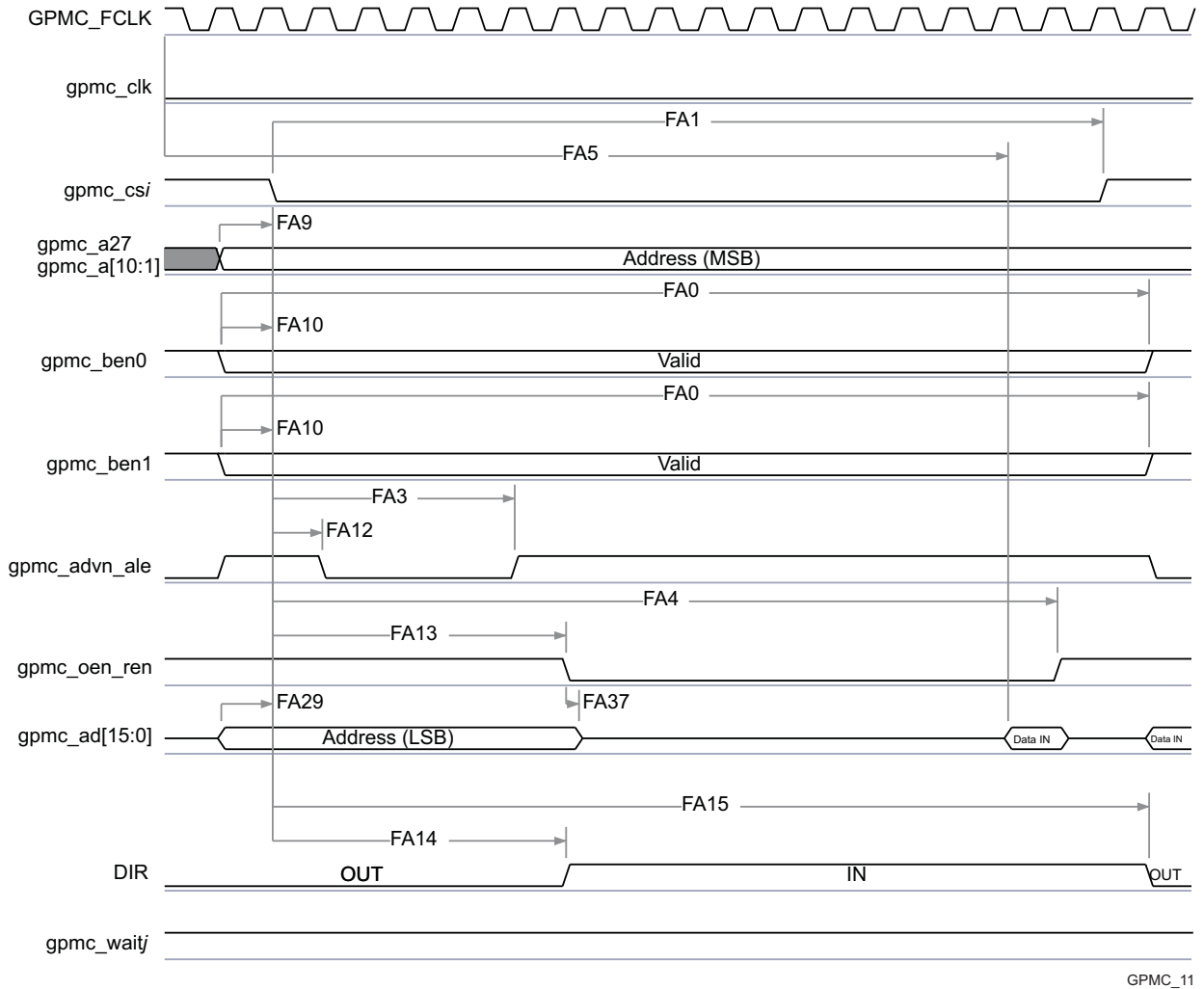

GPMC\_11

**Figure 5-34. GPMC / Multiplexed NOR Flash - Asynchronous Read - Single Word Timing<sup>(1)(2)(3)(4)</sup>**

- (1) In gpmc\_csi, i = 0 to 7. In gpmc\_waitj, j = 0 to 1
- (2) FA5 parameter illustrates amount of time required to internally sample input Data. It is expressed in number of GPMC functional clock cycles. From start of read cycle and after FA5 functional clock cycles, input Data will be internally sampled by active functional clock edge. FA5 value should be stored inside AccessTime register bits field.
- (3) GPMC\_FCLK is an internal clock (GPMC functional clock) not provided externally
- (4) The "DIR" (direction control) output signal is NOT pinned out on any of the device pads. It is an internal signal only representing a signal direction on the GPMC data bus.

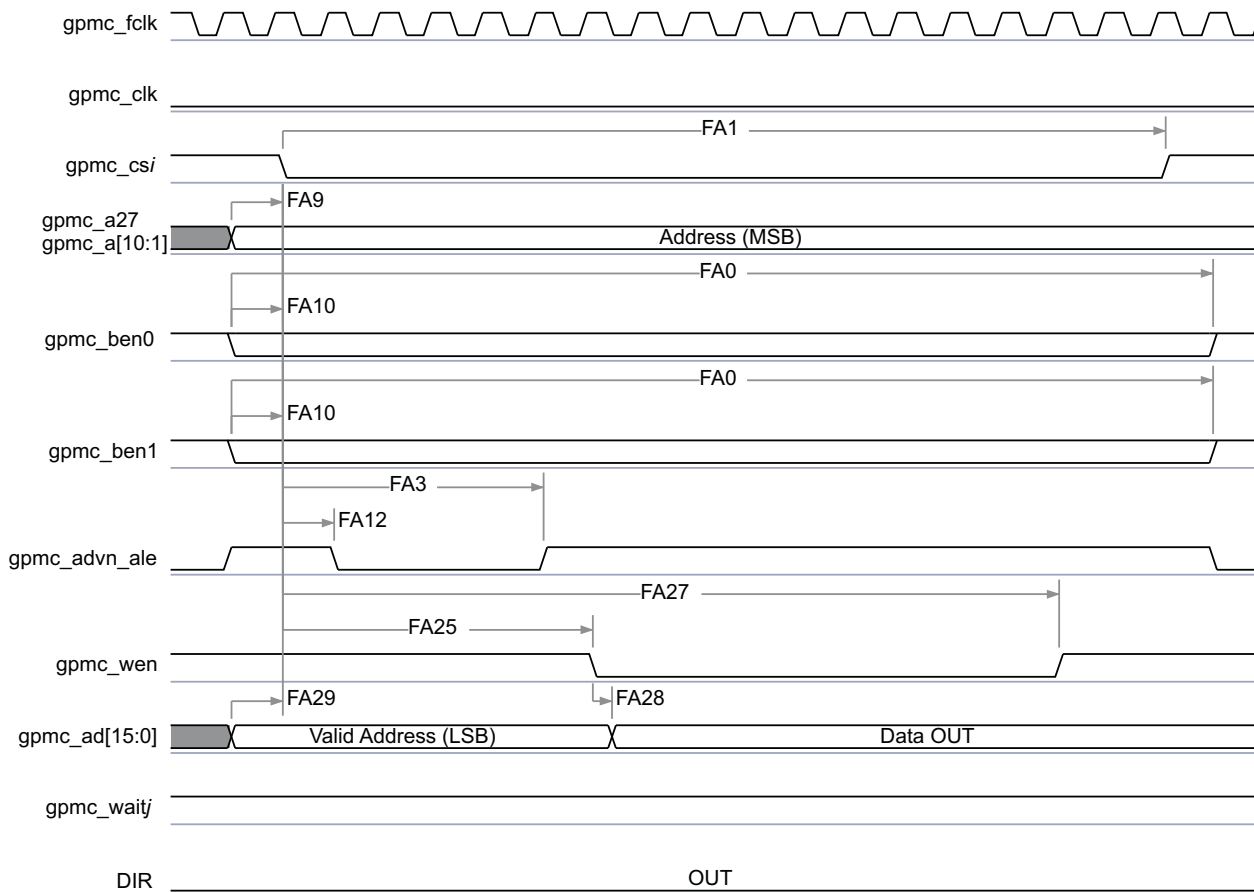

GPMC\_12

**Figure 5-35. GPMC / Multiplexed NOR Flash - Asynchronous Write - Single Word Timing<sup>(1)(2)</sup>**

- (1) In gpmc\_csi, i = 0 to 7. In gpmc\_waitj, j = 0 to 1.
- (2) The "DIR" (direction control) output signal is NOT pinned out on any of the device pads. It is an internal signal only representing a signal direction on the GPMC data bus.

**5.10.6.7.3 GPMC/NAND Flash Interface Asynchronous Timing**

**CAUTION**

The IO Timings provided in this section are only valid for some GPMC usage modes when the corresponding Virtual IO Timings or Manual IO Timings are configured as described in the tables found in this section.

Table 5-62 and Table 5-63 assume testing over the recommended operating conditions and electrical characteristic conditions below (see Figure 5-36, Figure 5-37, Figure 5-38, and Figure 5-39).

**Table 5-62. GPMC/NAND Flash Interface Timing Requirements**

NO.	PARAMETER	DESCRIPTION	MIN	MAX	UNIT
GNF12	t <sub>acc(DAT)</sub>	Data maximum access time (GPMC_FCLK Cycles)		J <sup>(1)</sup>	cycles
-	t <sub>su(DV-OEH)</sub>	Setup time, read gpmc_ad[15:0] valid before gpmc_oen_ren high	1.9		ns
-	t <sub>h(OEH-DV)</sub>	Hold time, read gpmc_ad[15:0] valid after gpmc_oen_ren high	1		ns

(1)  $J = \text{AccessTime} \times (\text{TimeParaGranularity} + 1)$

**Table 5-63. GPMC/NAND Flash Interface Switching Characteristics**

NO.	PARAMETER	DESCRIPTION	MIN	MAX	UNIT
GNF0	$t_{w(nWEV)}$	Pulse duration, gpmc_wen valid time		A <sup>(1)</sup>	ns
GNF1	$t_{d(nCSV-nWEV)}$	Delay time, gpmc_cs[7:0] valid to gpmc_wen valid	B - 2 <sup>(2)</sup>	B + 4 <sup>(2)</sup>	ns
GNF2	$t_{d(CLEH-nWEV)}$	Delay time, gpmc_ben[1:0] high to gpmc_wen valid	C - 2 <sup>(3)</sup>	C + 4 <sup>(3)</sup>	ns
GNF3	$t_{d(nWEV-DV)}$	Delay time, gpmc_ad[15:0] valid to gpmc_wen valid	D - 2 <sup>(4)</sup>	D + 4 <sup>(4)</sup>	ns
GNF4	$t_{d(nWEIV-DIV)}$	Delay time, gpmc_wen invalid to gpmc_ad[15:0] invalid	E - 2 <sup>(5)</sup>	E + 4 <sup>(5)</sup>	ns
GNF5	$t_{d(nWEIV-CLEIV)}$	Delay time, gpmc_wen invalid to gpmc_ben[1:0] invalid	F - 2 <sup>(6)</sup>	F + 4 <sup>(6)</sup>	ns
GNF6	$t_{d(nWEIV-nCSiV)}$	Delay time, gpmc_wen invalid to gpmc_cs[7:0] invalid	G - 2 <sup>(7)</sup>	G + 4 <sup>(7)</sup>	ns
GNF7	$t_{d(ALEH-nWEV)}$	Delay time, gpmc_advn_ale high to gpmc_wen valid	C - 2 <sup>(3)</sup>	C + 4 <sup>(3)</sup>	ns
GNF8	$t_{d(nWEIV-ALEIV)}$	Delay time, gpmc_wen invalid to gpmc_advn_ale invalid	F - 2 <sup>(6)</sup>	F + 4 <sup>(6)</sup>	ns
GNF9	$t_{c(nWE)}$	Cycle time, write cycle time		H <sup>(8)</sup>	ns
GNF10	$t_{d(nCSV-nOEV)}$	Delay time, gpmc_cs[7:0] valid to gpmc_oen_ren valid	I - 2 <sup>(9)</sup>	I + 4 <sup>(9)</sup>	ns
GNF13	$t_{w(nOEV)}$	Pulse duration, gpmc_oen_ren valid time		K <sup>(10)</sup>	ns
GNF14	$t_{c(nOE)}$	Cycle time, read cycle time		L <sup>(11)</sup>	ns
GNF15	$t_{d(nOEIV-nCSiV)}$	Delay time, gpmc_oen_ren invalid to gpmc_cs[7:0] invalid	M - 2 <sup>(12)</sup>	M + 4 <sup>(12)</sup>	ns

- (1)  $A = (\text{WEOffTime} - \text{WEOnTime}) \times (\text{TimeParaGranularity} + 1) \times \text{GPMC\_FCLK}$
- (2)  $B = ((\text{WEOnTime} - \text{CSOnTime}) \times (\text{TimeParaGranularity} + 1) + 0.5 \times (\text{WEEExtraDelay} - \text{CSEExtraDelay})) \times \text{GPMC\_FCLK}$
- (3)  $C = ((\text{WEOnTime} - \text{ADVOnTime}) \times (\text{TimeParaGranularity} + 1) + 0.5 \times (\text{WEEExtraDelay} - \text{ADVExtraDelay})) \times \text{GPMC\_FCLK}$
- (4)  $D = (\text{WEOnTime} \times (\text{TimeParaGranularity} + 1) + 0.5 \times \text{WEEExtraDelay}) \times \text{GPMC\_FCLK}$
- (5)  $E = (\text{WrCycleTime} - \text{WEOffTime} \times (\text{TimeParaGranularity} + 1) - 0.5 \times \text{WEEExtraDelay}) \times \text{GPMC\_FCLK}$
- (6)  $F = (\text{ADVWrOffTime} - \text{WEOffTime} \times (\text{TimeParaGranularity} + 1) + 0.5 \times (\text{ADVExtraDelay} - \text{WEEExtraDelay})) \times \text{GPMC\_FCLK}$
- (7)  $G = (\text{CSWrOffTime} - \text{WEOffTime} \times (\text{TimeParaGranularity} + 1) + 0.5 \times (\text{CSEExtraDelay} - \text{WEEExtraDelay})) \times \text{GPMC\_FCLK}$
- (8)  $H = \text{WrCycleTime} \times (1 + \text{TimeParaGranularity}) \times \text{GPMC\_FCLK}$
- (9)  $I = ((\text{OEOffTime} + (n - 1) \times \text{PageBurstAccessTime} - \text{CSOnTime}) \times (\text{TimeParaGranularity} + 1) + 0.5 \times (\text{OEEExtraDelay} - \text{CSEExtraDelay})) \times \text{GPMC\_FCLK}$
- (10)  $K = (\text{OEOffTime} - \text{OEOnTime}) \times (1 + \text{TimeParaGranularity}) \times \text{GPMC\_FCLK}$
- (11)  $L = \text{RdCycleTime} \times (1 + \text{TimeParaGranularity}) \times \text{GPMC\_FCLK}$
- (12)  $M = (\text{CSRdOffTime} - \text{OEOffTime} \times (\text{TimeParaGranularity} + 1) + 0.5 \times (\text{CSEExtraDelay} - \text{OEEExtraDelay})) \times \text{GPMC\_FCLK}$

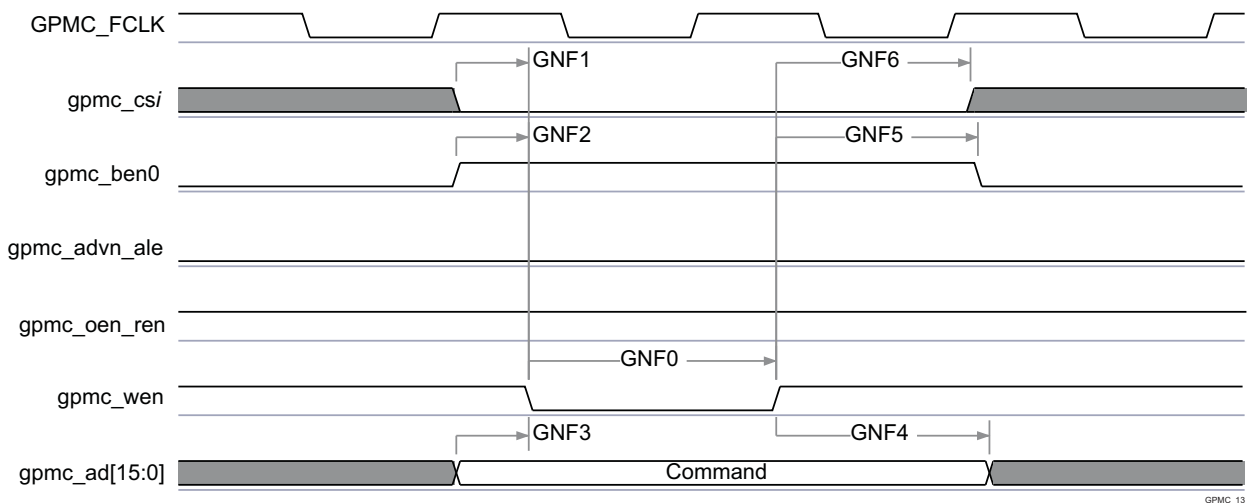

**Figure 5-36. GPMC / NAND Flash - Command Latch Cycle Timing<sup>(1)</sup>**

(1) In gpmc\_csi, i = 0 to 7.



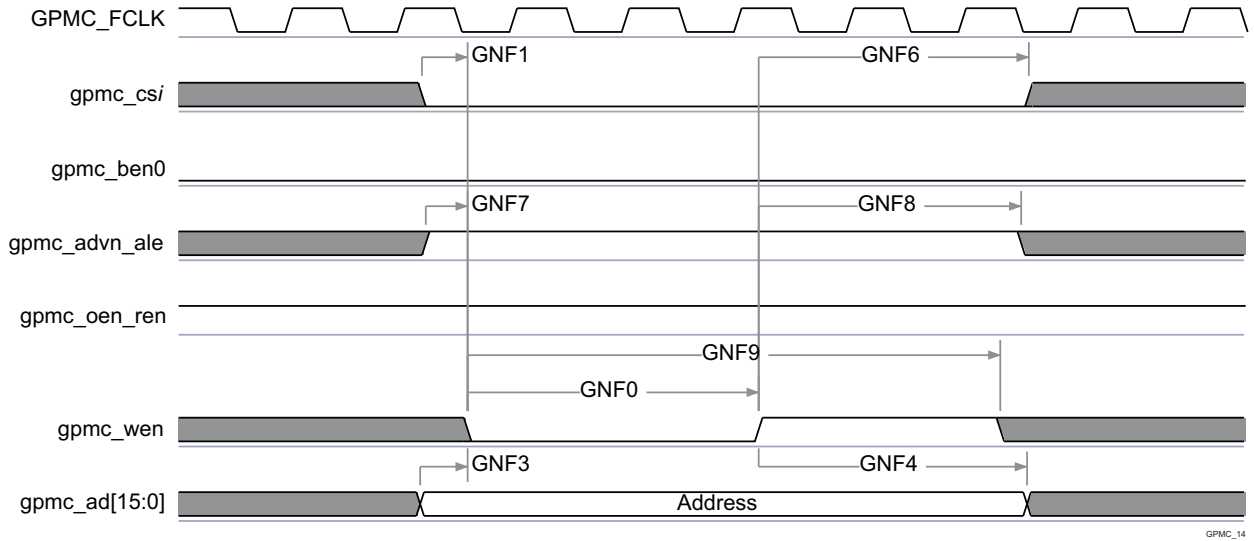

Figure 5-37. GPMC / NAND Flash - Address Latch Cycle Timing<sup>(1)</sup>

(1) In gpmc\_csi, i = 0 to 7.

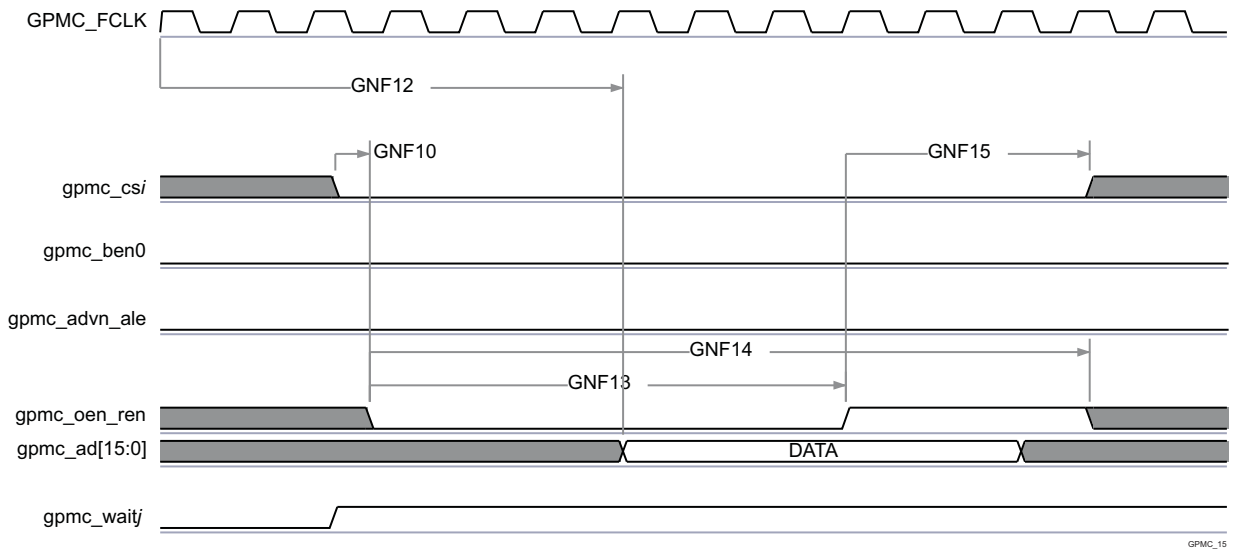
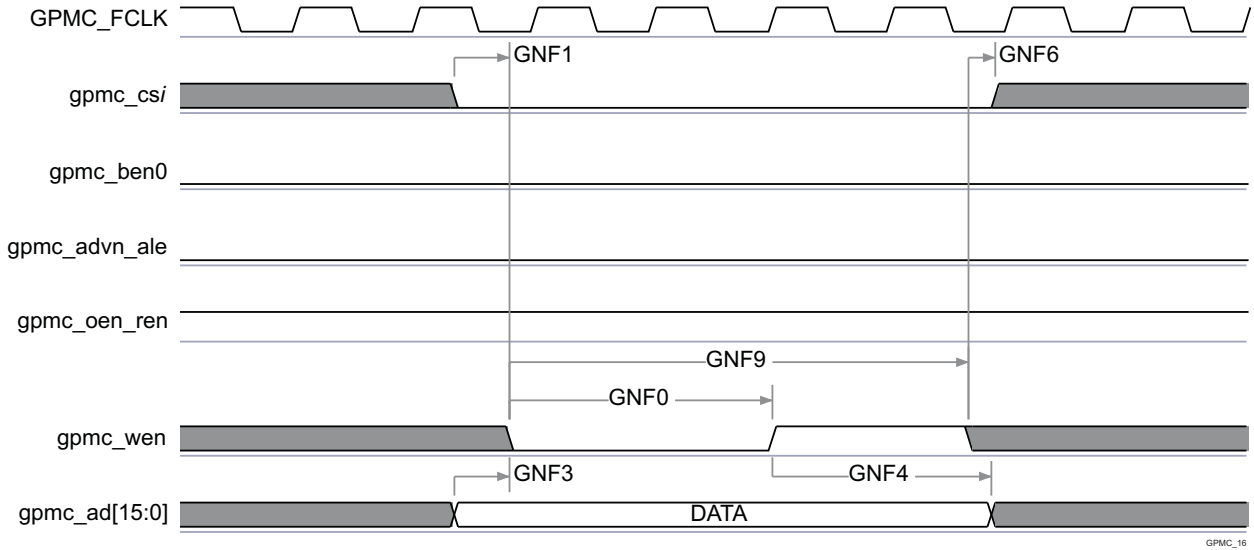

Figure 5-38. GPMC / NAND Flash - Data Read Cycle Timing<sup>(1)(2)(3)</sup>

- (1) GNF12 parameter illustrates amount of time required to internally sample input Data. It is expressed in number of GPMC functional clock cycles. From start of read cycle and after GNF12 functional clock cycles, input data will be internally sampled by active functional clock edge. GNF12 value must be stored inside AccessTime register bits field.
- (2) GPMC\_FCLK is an internal clock (GPMC functional clock) not provided externally.
- (3) In gpmc\_csi, i = 0 to 7. In gpmc\_waitj, j = 0 to 1.



**Figure 5-39. GPMC / NAND Flash - Data Write Cycle Timing<sup>(1)</sup>**

(1) In gpmc\_csi, i = 0 to 7.

**NOTE**

To configure the desired virtual mode the user must set MODESELECT bit and DELAYMODE bit field for each corresponding pad control register.

The pad control registers are presented in [Table 4-33](#) and described in chapter Control Module in the device TRM.

Virtual IO Timings Modes must be used to ensure some IO timings for GPMC. See [Table 5-33, Modes Summary](#) for a list of IO timings requiring the use of Virtual IO Timings Modes. See [Table 5-64, Virtual Functions Mapping for GPMC](#) for a definition of the Virtual modes.

[Table 5-64](#) presents the values for DELAYMODE bit field.

**Table 5-64. Virtual Functions Mapping for GPMC**

BALL	BALL NAME	Delay Mode Value	MUXMODE[15:0]									
			GPMC_VIRTUAL1	0	1	2	3	5	6	14 <sup>(1)</sup>	14 <sup>(1)</sup>	
M6	gpmc_ad0	11	gpmc_ad0									
M2	gpmc_ad1	11	gpmc_ad1									
L5	gpmc_ad2	11	gpmc_ad2									
M1	gpmc_ad3	11	gpmc_ad3									
L6	gpmc_ad4	11	gpmc_ad4									
L4	gpmc_ad5	11	gpmc_ad5									
L3	gpmc_ad6	11	gpmc_ad6									
L2	gpmc_ad7	11	gpmc_ad7									
L1	gpmc_ad8	11	gpmc_ad8									
K2	gpmc_ad9	11	gpmc_ad9									
J1	gpmc_ad10	11	gpmc_ad10									
J2	gpmc_ad11	11	gpmc_ad11									
H1	gpmc_ad12	11	gpmc_ad12									
J3	gpmc_ad13	11	gpmc_ad13									
H2	gpmc_ad14	11	gpmc_ad14									
H3	gpmc_ad15	11	gpmc_ad15									
R6	gpmc_a0	11	gpmc_a0								gpmc_a26	gpmc_a16
T9	gpmc_a1	11	gpmc_a1									
T6	gpmc_a2	11	gpmc_a2									
T7	gpmc_a3	10	gpmc_a3									
P6	gpmc_a4	10	gpmc_a4									
R9	gpmc_a5	11	gpmc_a5									
R5	gpmc_a6	11	gpmc_a6									
P5	gpmc_a7	11	gpmc_a7									
N7	gpmc_a8	12	gpmc_a8									
R4	gpmc_a9	12	gpmc_a9									
N9	gpmc_a10	12	gpmc_a10									
P9	gpmc_a11	11	gpmc_a11									
P4	gpmc_a12	13	gpmc_a12					gpmc_a0				
R3	gpmc_a13	12	gpmc_a13									
T2	gpmc_a14	12	gpmc_a14									
U2	gpmc_a15	12	gpmc_a15									

**Table 5-64. Virtual Functions Mapping for GPMC (continued)**

BALL	BALL NAME	Delay Mode Value	MUXMODE[15:0]										
			GPMC_VIRTUAL1	0	1	2	3	5	6	14 <sup>(1)</sup>	14 <sup>(1)</sup>		
U1	gpmc_a16	12	gpmc_a16										
P3	gpmc_a17	12	gpmc_a17										
R2	gpmc_a18	12	gpmc_a18										
K7	gpmc_a19	11	gpmc_a19			gpmc_a13							
M7	gpmc_a20	11	gpmc_a20			gpmc_a14							
J5	gpmc_a21	11	gpmc_a21			gpmc_a15							
K6	gpmc_a22	11	gpmc_a22			gpmc_a16							
J7	gpmc_a23	11	gpmc_a23			gpmc_a17							
J4	gpmc_a24	11	gpmc_a24			gpmc_a18							
J6	gpmc_a25	11	gpmc_a25			gpmc_a19							
H4	gpmc_a26	11	gpmc_a26			gpmc_a20							
H5	gpmc_a27	11	gpmc_a27			gpmc_a21							
H6	gpmc_cs1	11	gpmc_cs1			gpmc_a22							
T1	gpmc_cs0	14	gpmc_cs0										
P2	gpmc_cs2	12	gpmc_cs2							gpmc_a23		gpmc_a13	
P1	gpmc_cs3	10	gpmc_cs3					gpmc_a1		gpmc_a24		gpmc_a14	
P7	gpmc_clk	12	gpmc_clk	gpmc_cs7			gpmc_wait1			gpmc_a20			
N1	gpmc_advn_ale	13	gpmc_advn_ale	gpmc_cs6			gpmc_wait1	gpmc_a2	gpmc_a23	gpmc_a19			
M5	gpmc_oen_ren	14	gpmc_oen_ren										
M3	gpmc_wen	14	gpmc_wen										
N6	gpmc_ben0	11	gpmc_ben0	gpmc_cs4						gpmc_a21			
M4	gpmc_ben1	11	gpmc_ben1	gpmc_cs5				gpmc_a3		gpmc_a22			
N2	gpmc_wait0	14	gpmc_wait0							gpmc_a25		gpmc_a15	
E1	vin2a_clk0	11								gpmc_a27		gpmc_a17	
H7	vin2a_fld0	11								gpmc_a27		gpmc_a18	
G1	vin2a_hsync0	9								gpmc_a27			
F5	vin2a_d8	9								gpmc_a26			
E6	vin2a_d9	9								gpmc_a25			
D3	vin2a_d10	9								gpmc_a24			
F6	vin2a_d11	9								gpmc_a23			
F6	vin2a_d11	9								gpmc_a23			
AG5	vin1a_d11	9						gpmc_a23					

**Table 5-64. Virtual Functions Mapping for GPMC (continued)**

BALL	BALL NAME	Delay Mode Value GPMC_VIRTUAL1	MUXMODE[15:0]							
			0	1	2	3	5	6	14 <sup>(1)</sup>	14 <sup>(1)</sup>
AF2	vin1a_d12	9					gpmc_a24			
AF6	vin1a_d13	9					gpmc_a25			
AF3	vin1a_d14	9					gpmc_a26			
AF4	vin1a_d15	9					gpmc_a27			

(1) Some signals listed are virtual functions that present alternate multiplexing options. These virtual functions are controlled via CTRL\_CORE\_ALT\_SELECT\_MUX or CTRL\_CORE\_VIP\_MUX\_SELECT registers. For more information on how to use these options, refer to the device TRM, chapter Control Module, section Pad Configuration Registers.

### 5.10.6.8 I2C

The device includes 5 inter-integrated circuit (I2C) modules which provide an interface to other devices compliant with Philips Semiconductors Inter-IC bus (I2C) specification version 2.1. External components attached to this 2-wire serial bus can transmit/receive 8-bit data to/from the device through the I2C module.

#### NOTE

Note that, on I2C1 and I2C2, due to characteristics of the open drain IO cells, HS mode is not supported.

#### NOTE

Inter-integrated circuit *i* (*i* = 1 to 5) module is also referred to as I2Ci.

#### NOTE

For more information, see *Multimaster High Speed I2C Controller* section in the device TRM.

Table 5-65, Table 5-66 and Figure 5-40 assume testing over the recommended operating conditions and electrical characteristic conditions below.

**Table 5-65. Timing Requirements for I2C Input Timings<sup>(1)</sup>**

NO.	PARAMETER	DESCRIPTION	STANDARD MODE		FAST MODE		UNIT
			MIN	MAX	MIN	MAX	
I1	$t_{c(SCL)}$	Cycle time, SCL	10		2.5		$\mu$ s
I2	$t_{su(SCLH-SDAL)}$	Setup time, SCL high before SDA low (for a repeated START condition)	4.7		0.6		$\mu$ s
I3	$t_{h(SDAL-SCLL)}$	Hold time, SCL low after SDA low (for a START and a repeated START condition)	4		0.6		$\mu$ s
I4	$t_{w(SCLL)}$	Pulse duration, SCL low	4.7		1.3		$\mu$ s
I5	$t_{w(SCLH)}$	Pulse duration, SCL high	4		0.6		$\mu$ s
I6	$t_{su(SDAV-SCLH)}$	Setup time, SDA valid before SCL high	250		100 <sup>(2)</sup>		ns
I7	$t_{h(SCLL-SDAV)}$	Hold time, SDA valid after SCL low	0 <sup>(3)</sup>	3.45 <sup>(4)</sup>	0 <sup>(3)</sup>	0.9 <sup>(4)</sup>	$\mu$ s
I8	$t_{w(SDAH)}$	Pulse duration, SDA high between STOP and START conditions	4.7		1.3		$\mu$ s
I9	$t_{r(SDA)}$	Rise time, SDA		1000	$20 + 0.1C_B$ <sup>(5)</sup>	300 <sup>(3)</sup>	ns
I10	$t_{r(SCL)}$	Rise time, SCL		1000	$20 + 0.1C_B$ <sup>(5)</sup>	300 <sup>(3)</sup>	ns
I11	$t_{f(SDA)}$	Fall time, SDA		300	$20 + 0.1C_B$ <sup>(5)</sup>	300 <sup>(3)</sup>	ns
I12	$t_{f(SCL)}$	Fall time, SCL		300	$20 + 0.1C_B$ <sup>(5)</sup>	300 <sup>(3)</sup>	ns
I13	$t_{su(SCLH-SDAH)}$	Setup time, SCL high before SDA high (for STOP condition)	4		0.6		$\mu$ s
I14	$t_{w(SP)}$	Pulse duration, spike (must be suppressed)			0	50	ns
I15	$C_B$ <sup>(5)</sup>	Capacitive load for each bus line		400		400	pF

(1) The I2C pins SDA and SCL do not feature fail-safe I/O buffers. These pins could potentially draw current when the device is powered down.

(2) A Fast-mode I2C device can be used in a Standard-mode I2C system, but the requirement  $t_{su(SDA-SCLH)} \geq 250$  ns must then be met. This will automatically be the case if the device does not stretch the LOW period of the SCL signal. If such a device does stretch the LOW period of the SCL signal, it must output the next data bit to the SDA line  $t_r \text{ max} + t_{su(SDA-SCLH)} = 1000 + 250 = 1250$  ns (according to the Standard-mode I2C Specification) before the SCL line is released.

(3) A device must internally provide a hold time of at least 300 ns for the SDA signal (referred to the  $V_{IHmin}$  of the SCL signal) to bridge the undefined region of the falling edge of SCL.

- (4) The maximum  $t_{h(SDA-SCLL)}$  has only to be met if the device does not stretch the low period  $[t_{w(SCLL)}]$  of the SCL signal.
- (5)  $C_B$  = total capacitance of one bus line in pF. If mixed with HS-mode devices, faster fall-times are allowed.

**Table 5-66. Timing Requirements for I2C HS-Mode (I2C3/4/5 Only)<sup>(1)</sup>**

NO.	PARAMETER	DESCRIPTION	$C_b = 100 \text{ pF MAX}$		$C_b = 400 \text{ pF}^{(2)}$		UNIT
			MIN	MAX	MIN	MAX	
I1	$t_{c(SCL)}$	Cycle time, SCL	0.294		0.588		$\mu\text{s}$
I2	$t_{su(SCLH-SDAL)}$	Set-up time, SCL high before SDA low (for a repeated START condition)	160		160		ns
I3	$t_{h(SDAL-SCLL)}$	Hold time, SCL low after SDA low (for a repeated START condition)	160		160		ns
I4	$t_{w(SCLL)}$	LOW period of the SCLH clock	160		320		ns
I5	$t_{w(SCLH)}$	HIGH period of the SCLH clock	60		120		ns
I6	$t_{su(SDAV-SCLH)}$	Setup time, SDA valid before SCL high	10		10		ns
I7	$t_{h(SCLL-SDAV)}$	Hold time, SDA valid after SCL low	0 <sup>(3)</sup>	70	0 <sup>(3)</sup>	150	ns
I13	$t_{su(SCLH-SDAH)}$	Setup time, SCL high before SDA high (for a STOP condition)	160		160		ns
I14	$t_{w(SP)}$	Pulse duration, spike (must be suppressed)	0	10	0	10	ns
I15	$C_B^{(2)}$	Capacitive load for SDAH and SCLH lines	100		400		pF
I16	$C_B$	Capacitive load for SDAH + SDA line and SCLH + SCL line	400		400		pF

- (1) I2C HS-Mode is only supported on I2C3/4/5. I2C HS-Mode is not supported on I2C1/2.
- (2) For bus line loads  $C_B$  between 100 and 400 pF the timing parameters must be linearly interpolated.
- (3) A device must internally provide a Data hold time to bridge the undefined part between  $V_{IH}$  and  $V_{IL}$  of the falling edge of the SCLH signal. An input circuit with a threshold as low as possible for the falling edge of the SCLH signal minimizes this hold time.

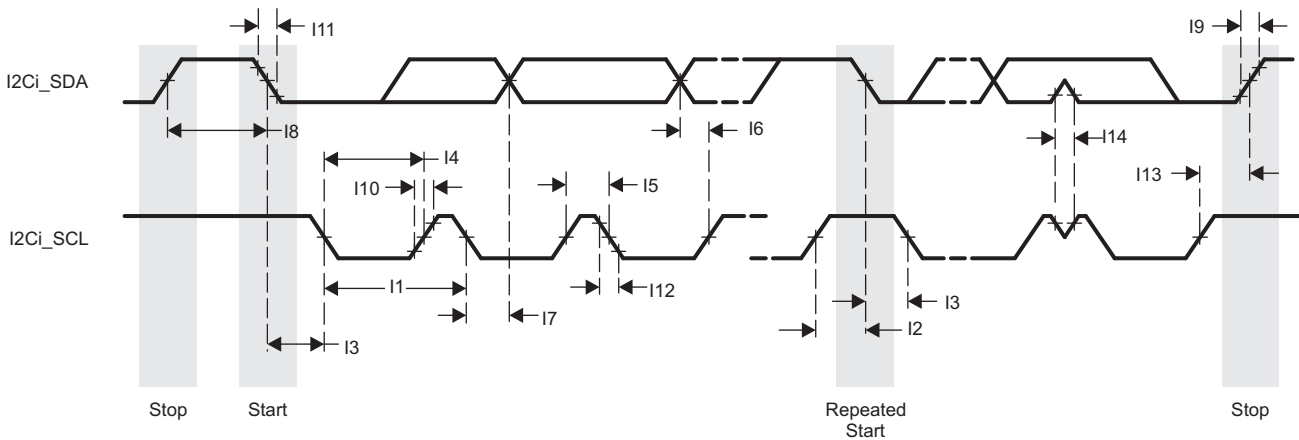

**Figure 5-40. I2C Receive Timing**

Table 5-67 and Figure 5-41 assume testing over the recommended operating conditions and electrical characteristic conditions below.

**Table 5-67. Switching Characteristics Over Recommended Operating Conditions for I2C Output Timings<sup>(2)</sup>**

NO.	PARAMETER	DESCRIPTION	STANDARD MODE		FAST MODE		UNIT
			MIN	MAX	MIN	MAX	
I16	$t_{c(SCL)}$	Cycle time, SCL	10		2.5		$\mu\text{s}$

**Table 5-67. Switching Characteristics Over Recommended Operating Conditions for I2C Output Timings<sup>(2)</sup> (continued)**

NO.	PARAMETER	DESCRIPTION	STANDARD MODE		FAST MODE		UNIT
			MIN	MAX	MIN	MAX	
I17	$t_{su}(SCLH-SDAL)$	Setup time, SCL high before SDA low (for a repeated START condition)	4.7		0.6		$\mu s$
I18	$t_h(SDAL-SCLL)$	Hold time, SCL low after SDA low (for a START and a repeated START condition)	4		0.6		$\mu s$
I19	$t_w(SCLL)$	Pulse duration, SCL low	4.7		1.3		$\mu s$
I20	$t_w(SCLH)$	Pulse duration, SCL high	4		0.6		$\mu s$
I21	$t_{su}(SDAV-SCLH)$	Setup time, SDA valid before SCL high	250		100		ns
I22	$t_h(SCLL-SDAV)$	Hold time, SDA valid after SCL low (for I2C bus devices)	0	3.45	0	0.9	$\mu s$
I23	$t_w(SDAH)$	Pulse duration, SDA high between STOP and START conditions	4.7		1.3		$\mu s$
I24	$t_r(SDA)$	Rise time, SDA		1000	$20 + 0.1C_B^{(1)(3)}$	$300^{(3)}$	ns
I25	$t_r(SCL)$	Rise time, SCL		1000	$20 + 0.1C_B^{(1)(3)}$	$300^{(3)}$	ns
I26	$t_f(SDA)$	Fall time, SDA		300	$20 + 0.1C_B^{(1)(3)}$	$300^{(3)}$	ns
I27	$t_f(SCL)$	Fall time, SCL		300	$20 + 0.1C_B^{(1)(3)}$	$300^{(3)}$	ns
I28	$t_{su}(SCLH-SDAH)$	Setup time, SCL high before SDA high (for STOP condition)	4		0.6		$\mu s$
I29	$C_p$	Capacitance for each I2C pin		10		10	pF

- (1)  $C_B$  = total capacitance of one bus line in pF. If mixed with HS-mode devices, faster fall-times are allowed.
- (2) Software must properly configure the I2C module registers to achieve the required timing parameters. For more information, see *Multimaster High Speed I2C Controller* section in the device TRM.
- (3) These timings apply only to I2C1 and I2C2. I2C3, I2C4, and I2C5 use standard LVCMOS buffers to emulate open-drain buffers and their rise/fall times should be referenced in the device IBIS model.

**NOTE**

I2C emulation is achieved by configuring the LVCMOS buffers to output Hi-Z instead of driving high when transmitting logic-1.

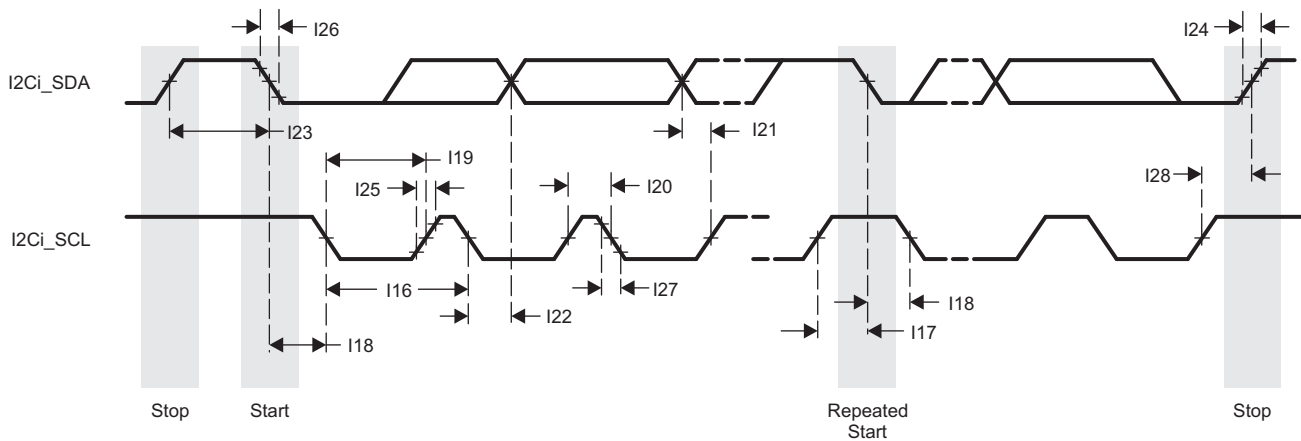

**Figure 5-41. I2C Transmit Timing**



### 5.10.6.9 HDQ1W

The module is intended to work with both HDQ and 1-Wire protocols. The protocols use a single wire to communicate between the master and the slave. The protocols employ an asynchronous return to one mechanism where, after any command, the line is pulled high.

#### NOTE

For more information, see *HDQ / 1-Wire* section in the device TRM.

#### 5.10.6.9.1 HDQ / 1-Wire — HDQ Mode

Table 5-68 and Table 5-69 assume testing over the recommended operating conditions and electrical characteristic conditions below (see Figure 5-42, Figure 5-43, Figure 5-44, and Figure 5-45).

**Table 5-68. HDQ/1-Wire Timing Requirements—HDQ Mode**

NO.	PARAMETER	DESCRIPTION	MIN	MAX	UNIT
HDQ1	$t_{CYCH}$	Read bit window timing	190	250	$\mu s$
HDQ2	$t_{HW1}$	Read one data valid after HDQ low	32 <sup>(2)</sup>	66 <sup>(2)</sup>	$\mu s$
HDQ3	$t_{HW0}$	Read zero data hold after HDQ low	70 <sup>(2)</sup>	145 <sup>(2)</sup>	$\mu s$
HDQ4	$t_{RSPS}$	Response time from HDQ slave device <sup>(1)</sup>	190	320	$\mu s$

(1) Defined by software.

(2) If the HDQ slave device drives a logic-low state after  $t_{HW0}$  maximum, it can be interpreted as a break pulse. For more information, see Table 5-69 and *HDQ/1-Wire* chapter in the device TRM.

**Table 5-69. HDQ / 1-Wire Switching Characteristics - HDQ Mode**

NO.	PARAMETER	DESCRIPTION	MIN	MAX	UNIT
HDQ5	$t_B$	Break timing	190		$\mu s$
HDQ6	$t_{BR}$	Break recovery time	40		$\mu s$
HDQ7	$t_{CYCD}$	Write bit windows timing	190		$\mu s$
HDQ8	$t_{DW1}$	Write one data valid after HDQ low	0.5	50	$\mu s$
HDQ9	$t_{DW0}$	Write zero data hold after HDQ low	86	145	$\mu s$

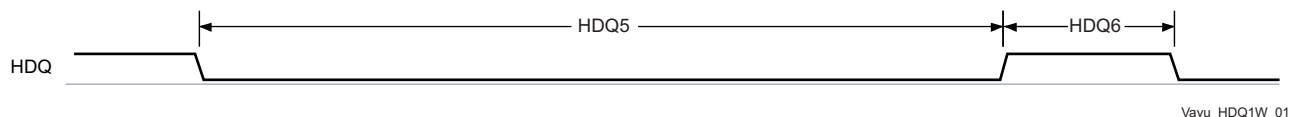

**Figure 5-42. HDQ Break and Break Recovery Timing — HDQ Interface Writing to Slave**

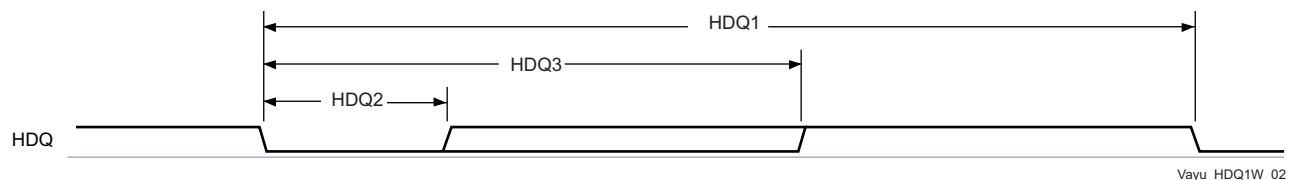

**Figure 5-43. Device HDQ Interface Bit Read Timing (Data)**

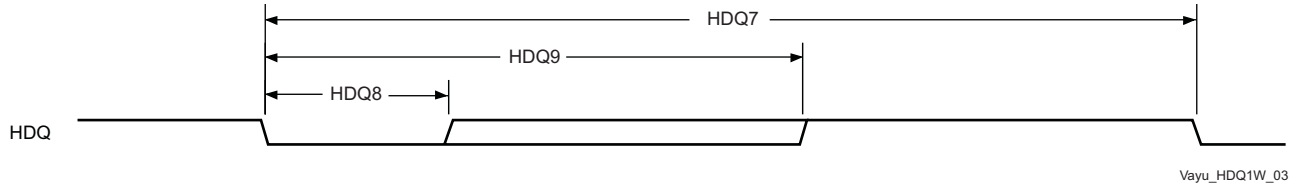

Figure 5-44. Device HDQ Interface Bit Write Timing (Command / Address or Data)

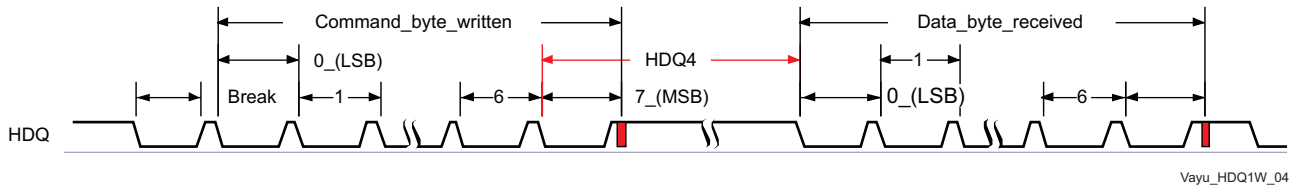

Figure 5-45. HDQ Communication Timing

5.10.6.9.2 HDQ/1-Wire—1-Wire Mode

Table 5-70 and Table 5-71 assume testing over the recommended operating conditions and electrical characteristic conditions below (see Figure 5-46, Figure 5-47, and Figure 5-48).

Table 5-70. HDQ / 1-Wire Timing Requirements - 1-Wire Mode

NO.	PARAMETER	DESCRIPTION	MIN	MAX	UNIT
HDQ10	t <sub>PDH</sub>	Presence pulse delay high	15	60	µs
HDQ11	t <sub>PDL</sub>	Presence pulse delay low	60	240	µs
HDQ12	t <sub>RDV</sub>	Read data valid time	t <sub>LOWR</sub>	15	µs
HDQ13	t <sub>REL</sub>	Read data release time	0	45	µs

Table 5-71. HDQ / 1-Wire Switching Characteristics - 1-Wire Mode

NO.	PARAMETER	DESCRIPTION	MIN	MAX	UNIT
HDQ14	t <sub>RSTL</sub>	Reset time low	480	960	µs
HDQ15	t <sub>RSTH</sub>	Reset time high	480		µs
HDQ16	t <sub>SLOT</sub>	Bit cycle time	60	120	µs
HDQ17	t <sub>LOW1</sub>	Write bit-one time	1	15	µs
HDQ18	t <sub>LOW0</sub>	Write bit-zero time <sup>(2)</sup>	60	120	µs
HDQ19	t <sub>REC</sub>	Recovery time	1		µs
HDQ20	t <sub>LOWR</sub>	Read bit strobe time <sup>(1)</sup>	1	15	µs

(1) t<sub>LOWR</sub> (low pulse sent by the master) must be as short as possible to maximize the master sampling window.

(2) t<sub>LOW0</sub> must be less than t<sub>SLOT</sub>.

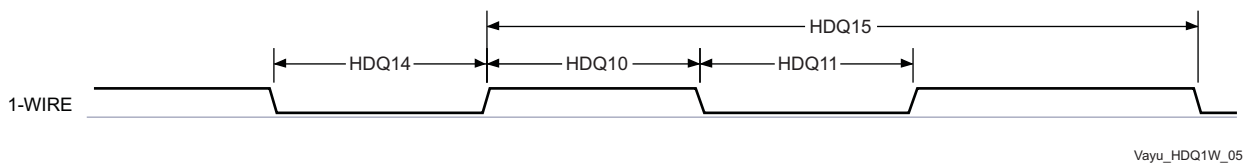

Figure 5-46. 1-Wire—Break (Reset)

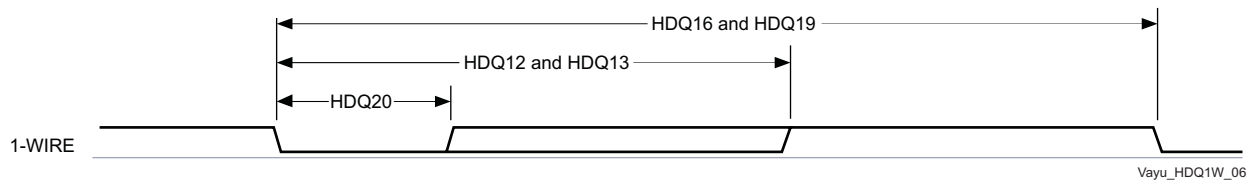

Figure 5-47. 1-Wire—Read Bit (Data)

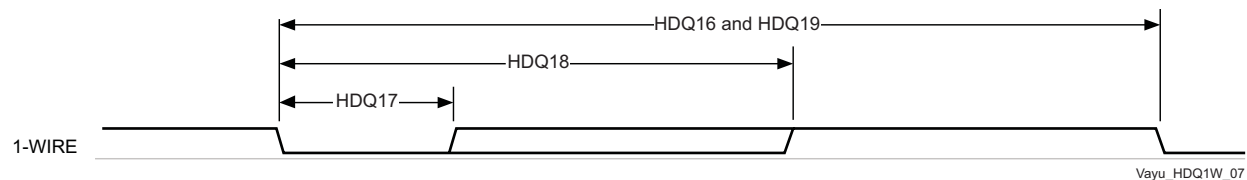

Figure 5-48. 1-Wire—Write Bit-One Timing (Command / Address or Data)

### 5.10.6.10 UART

The UART performs serial-to-parallel conversions on data received from a peripheral device and parallel-to-serial conversion on data received from the CPU. There are 10 UART modules in the device. Only one UART supports IrDA features. Each UART can be used for configuration and data exchange with a number of external peripheral devices or interprocessor communication between devices.

The UART<sub>i</sub> (where *i* = 1 to 10) include the following features:

- 16C750 compatibility
- 64-byte FIFO buffer for receiver and 64-byte FIFO for transmitter
- Baud generation based on programmable divisors *N* (where *N* = 1...16 384) operating from a fixed functional clock of 48 MHz or 192 MHz
- Break character detection and generation
- Configurable data format:
  - Data bit: 5, 6, 7, or 8 bits
  - Parity bit: Even, odd, none
  - Stop-bit: 1, 1.5, 2 bit(s)
- Flow control: Hardware (RTS/CTS) or software (XON/XOFF)
- Only UART1 module has extended modem control signals (DCD, RI, DTR, DSR)
- Only UART3 supports IrDA

#### NOTE

For more information, see *UART* section in the device TRM.

Table 5-72, Table 5-73 and Figure 5-49 assume testing over the recommended operating conditions and electrical characteristic conditions below.

Table 5-72. Timing Requirements for UART

NO.	PARAMETER	DESCRIPTION	MIN	MAX	UNIT
U1	$t_{w(RX)}$	Pulse width, receive data bit, 15/30/100 pF high or low	0.96U <sup>(1)</sup>	1.05U <sup>(1)</sup>	ns
U2	$t_{w(CTS)}$	Pulse width, receive start bit, 15/30/100 pF high or low	0.96U <sup>(1)</sup>	1.05U <sup>(1)</sup>	ns
U3	$t_{d(RTS-TX)}$	Delay time, transmit start bit to transmit data	P <sup>(2)</sup>		ns
U4	$t_{d(CTS-TX)}$	Delay time, receive start bit to transmit data	P <sup>(2)</sup>		ns

- (1)  $U = \text{UART baud time} = 1 / \text{programmed baud rate}$
- (2)  $P = \text{Clock period of the reference clock (FCLK, usually 48 MHz or 192 MHz)}$ .

**Table 5-73. Switching Characteristics Over Recommended Operating Conditions for UART**

NO.	PARAMETER	DESCRIPTION	MIN	MAX	UNIT
	$f_{(\text{baud})}$	Maximum programmable baud rate	15 pF	12	MHz
			30 pF	0.23	
			100 pF	0.115	
U5	$t_{w(\text{TX})}$	Pulse width, transmit data bit, 15/30/100 pF high or low	$U^{(1)} - 2$	$U^{(1)} + 2$	ns
U6	$t_{w(\text{RTS})}$	Pulse width, transmit start bit, 15/30/100 pF high or low	$U^{(1)} - 2$	$U^{(1)} + 2$	ns

- (1)  $U = \text{UART baud time} = 1/\text{programmed baud rate}$

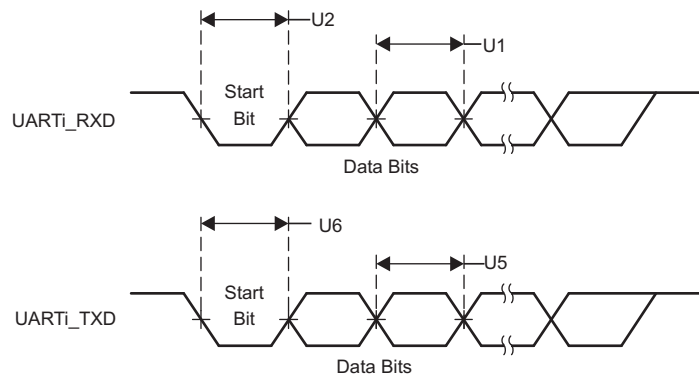

**Figure 5-49. UART Timing**

### 5.10.6.11 McSPI

The McSPI is a master/slave synchronous serial bus. There are four separate McSPI modules (SPI1, SPI2, SPI3, and SPI4) in the device. All these four modules support up to four external devices (four chip selects) and are able to work as both master and slave.

The McSPI modules include the following main features:

- Serial clock with programmable frequency, polarity, and phase for each channel
- Wide selection of SPI word lengths, ranging from 4 to 32 bits
- Up to four master channels, or single channel in slave mode
- Master multichannel mode:
  - Full duplex/half duplex
  - Transmit-only/receive-only/transmit-and-receive modes
  - Flexible input/output (I/O) port controls per channel
  - Programmable clock granularity
  - SPI configuration per channel. This means, clock definition, polarity enabling and word width
- Power management through wake-up capabilities
- Programmable timing control between chip select and external clock generation
- Built-in FIFO available for a single channel.
- Each SPI module supports multiple chip select pins  $\text{spim\_cs}[i]$ , where  $i = 1$  to 4.

**NOTE**

For more information, see *Serial Communication Interface* section in the device TRM.

**NOTE**

The McSPI<sub>m</sub> module (m = 1 to 4) is also referred to as SPI<sub>m</sub>.

**CAUTION**

The IO timings provided in this section are applicable for all combinations of signals for SPI1 and SPI2. However, the timings are only valid for SPI3 and SPI4 if signals within a single IOSET are used. The IOSETS are defined in the [Table 5-76](#).

[Table 5-74](#), [Figure 5-50](#) and [Figure 5-51](#) present timing requirements for McSPI - master mode.

**Table 5-74. Timing Requirements for SPI - Master Mode <sup>(1)(8)</sup>**

NO.	PARAMETER	DESCRIPTION	MODE	MIN	MAX	UNIT
SM1	$t_{c(SPICLK)}$	Cycle time, spi_sclk <sup>(1) (2)</sup>	SPI1/2/3/4	20.8 <sup>(3)</sup>		ns
SM2	$t_{w(SPICLKl)}$	Typical Pulse duration, spi_sclk low <sup>(1)</sup>		0.5*P-1 <sup>(4)</sup>		ns
SM3	$t_{w(SPICLKh)}$	Typical Pulse duration, spi_sclk high <sup>(1)</sup>		0.5*P-1 <sup>(4)</sup>		ns
SM4	$t_{su(MISO-SPICLK)}$	Setup time, spi_d[x] valid before spi_sclk active edge <sup>(1)</sup>		4.4		ns
SM5	$t_{h(SPICLK-MISO)}$	Hold time, spi_d[x] valid after spi_sclk active edge <sup>(1)</sup>		3.9		ns
SM6	$t_{d(SPICLK-SIMO)}$	Delay time, spi_sclk active edge to spi_d[x] transition <sup>(1)</sup>	SPI1	-4.27	4.27	ns
			SPI2	-4.32	4.32	ns
			SPI3	-5.37	4.23	ns
			SPI4	-3.81	4.41	ns
SM7	$t_{d(CS-SIMO)}$	Delay time, spi_cs[x] active edge to spi_d[x] transition			5	ns
SM8	$t_{d(CS-SPICLK)}$	Delay time, spi_cs[x] active to spi_sclk first edge <sup>(1)</sup>	MASTER_PHA0 <sup>(5)</sup>	B-4.6 <sup>(6)</sup>		ns
			MASTER_PHA1 <sup>(5)</sup>	A-4.6 <sup>(7)</sup>		ns
SM9	$t_{d(SPICLK-CS)}$	Delay time, spi_sclk last edge to spi_cs[x] inactive <sup>(1)</sup>	MASTER_PHA0 <sup>(5)</sup>	A-4.6 <sup>(7)</sup>		ns
			MASTER_PHA1 <sup>(5)</sup>	B-4.6 <sup>(6)</sup>		ns

(1) This timing applies to all configurations regardless of SPI\_CLK polarity and which clock edges are used to drive output data and capture input data.

(2) Related to the SPI\_CLK maximum frequency.

(3) 20.8 ns cycle time = 48 MHz

(4) P = SPICLK period.

(5) SPI\_CLK phase is programmable with the PHA bit of the SPI\_CH(i)CONF register.

(6)  $B = (TCS + 0.5) \times TSPICLKREF \times Fratio$ , where TCS is a bit field of the SPI\_CH(i)CONF register and Fratio = Even  $\geq 2$ .

(7) When P = 20.8 ns,  $A = (TCS + 1) \times TSPICLKREF$ , where TCS is a bit field of the SPI\_CH(i)CONF register. When P > 20.8 ns,  $A = (TCS + 0.5) \times Fratio \times TSPICLKREF$ , where TCS is a bit field of the SPI\_CH(i)CONF register.

(8) The IO timings provided in this section are applicable for all combinations of signals for SPI1 and SPI2. However, the timings are only valid for SPI3 and SPI4 if signals within a single IOSET are used. The IOSETS are defined in the following tables.

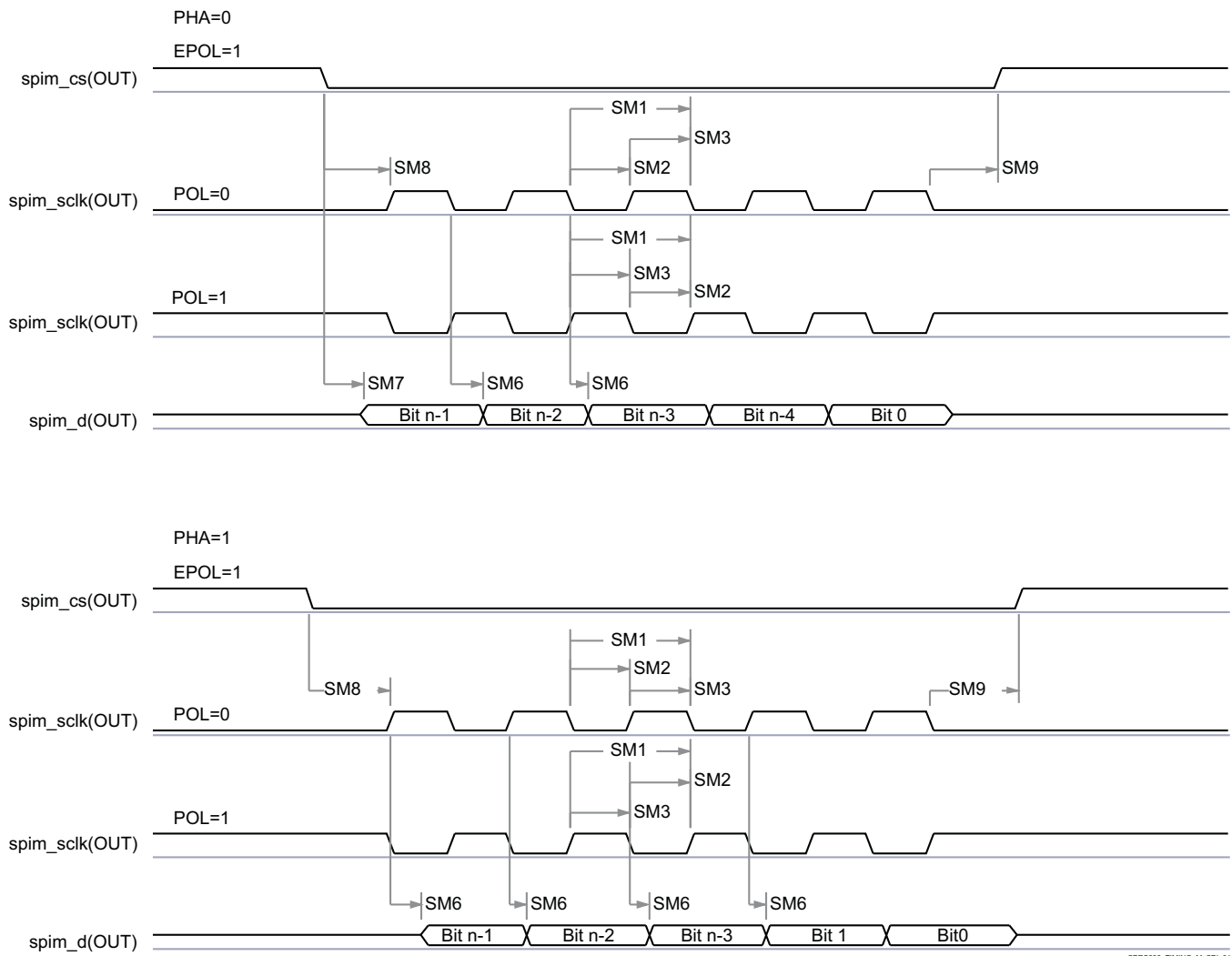

SPRS982\_TIMING\_McSPI\_01

Figure 5-50. McSPI - Master Mode Transmit

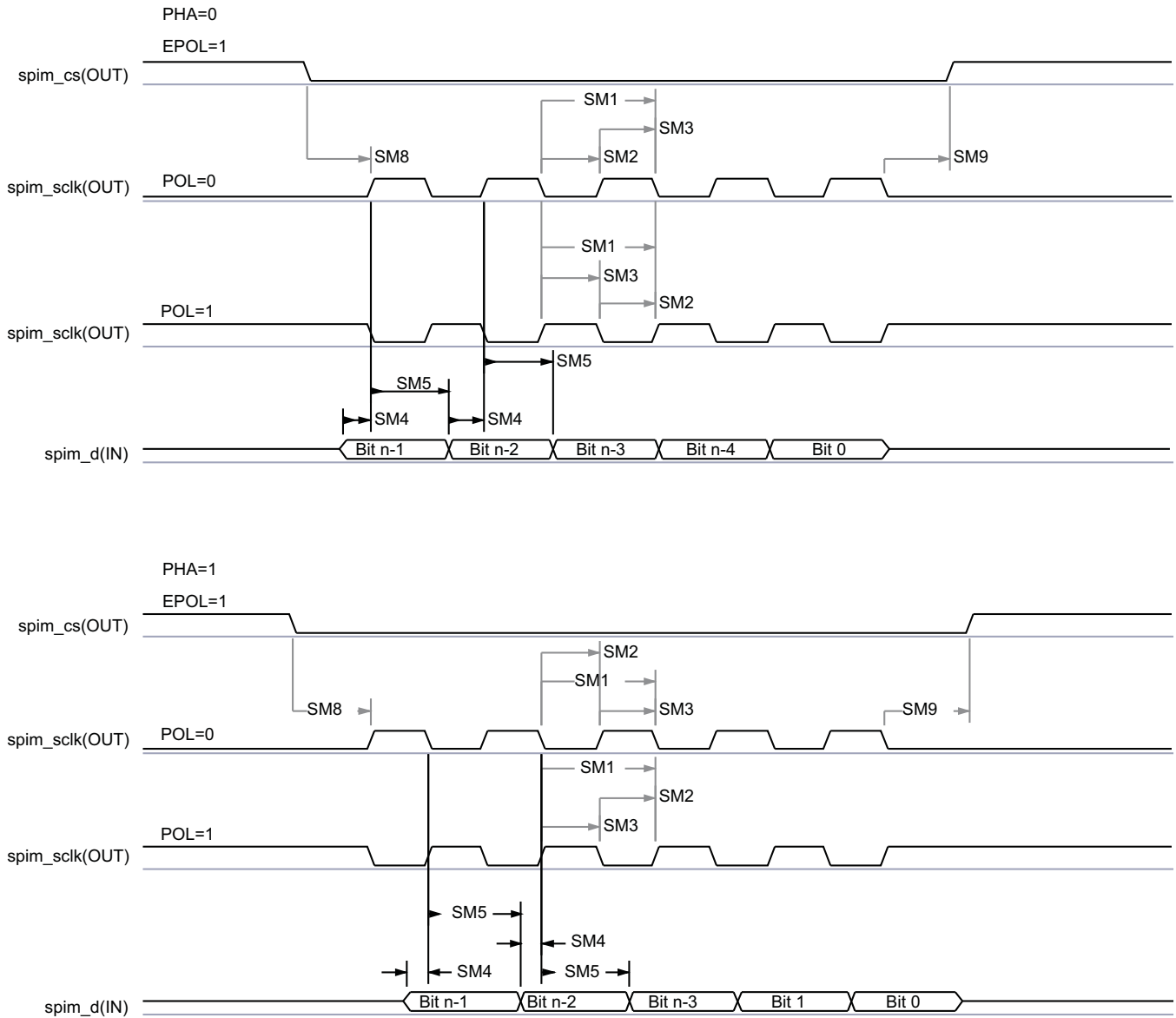

Figure 5-51. McSPI - Master Mode Receive

Table 5-75, Figure 5-52 and Figure 5-53 present timing requirements for McSPI - slave mode.

Table 5-75. Timing Requirements for SPI - Slave Mode<sup>(6)</sup>

NO.	PARAMETER	DESCRIPTION	MODE	MIN	MAX	UNIT
SS1 <sup>(2)(1)</sup>	$t_c(\text{SPICLK})$	Cycle time, spi_sclk <sup>(3)</sup>		62.5		ns
SS2 <sup>(1)</sup>	$t_w(\text{SPICLK}_L)$	Typical Pulse duration, spi_sclk low		0.45P <sup>(4)</sup>		ns
SS3 <sup>(1)</sup>	$t_w(\text{SPICLK}_H)$	Typical Pulse duration, spi_sclk high		0.45P <sup>(4)</sup>		ns
SS4 <sup>(1)</sup>	$t_{su}(\text{SIMO-SPICLK})$	Setup time, spi_d[x] valid before spi_sclk active edge		5		ns
SS5 <sup>(1)</sup>	$t_h(\text{SPICLK-SIMO})$	Hold time, spi_d[x] valid after spi_sclk active edge		5		ns
SS6 <sup>(1)</sup>	$t_d(\text{SPICLK-SOMI})$	Delay time, spi_sclk active edge to mcspi_somi transition	SPI1/2/3	2	26.1	ns
			SPI4	2	18	ns
SS7 <sup>(5)</sup>	$t_d(\text{CS-SOMI})$	Delay time, spi_cs[x] active edge to mcspi_somi transition			20.95	ns
SS8 <sup>(1)</sup>	$t_{su}(\text{CS-SPICLK})$	Setup time, spi_cs[x] valid before spi_sclk first edge		5		ns
SS9 <sup>(1)</sup>	$t_h(\text{SPICLK-CS})$	Hold time, spi_cs[x] valid after spi_sclk last edge		5		ns

- (1) This timing applies to all configurations regardless of SPI\_CLK polarity and which clock edges are used to drive output data and capture input data.
- (2) When operating the SPI interface in RX-only mode, the minimum Cycle time is 26 ns (38.4 MHz)
- (3) 62.5 ns Cycle time = 16 MHz
- (4) P = SPICLK period.
- (5) PHA = 0; SPI\_CLK phase is programmable with the PHA bit of the SPI\_CH(i)CONF register.
- (6) The IO timings provided in this section are applicable for all combinations of signals for SPI1 and SPI2. However, the timings are only valid for SPI3 and SPI4 if signals within a single IOSET are used. The IOSETs are defined in the following tables.

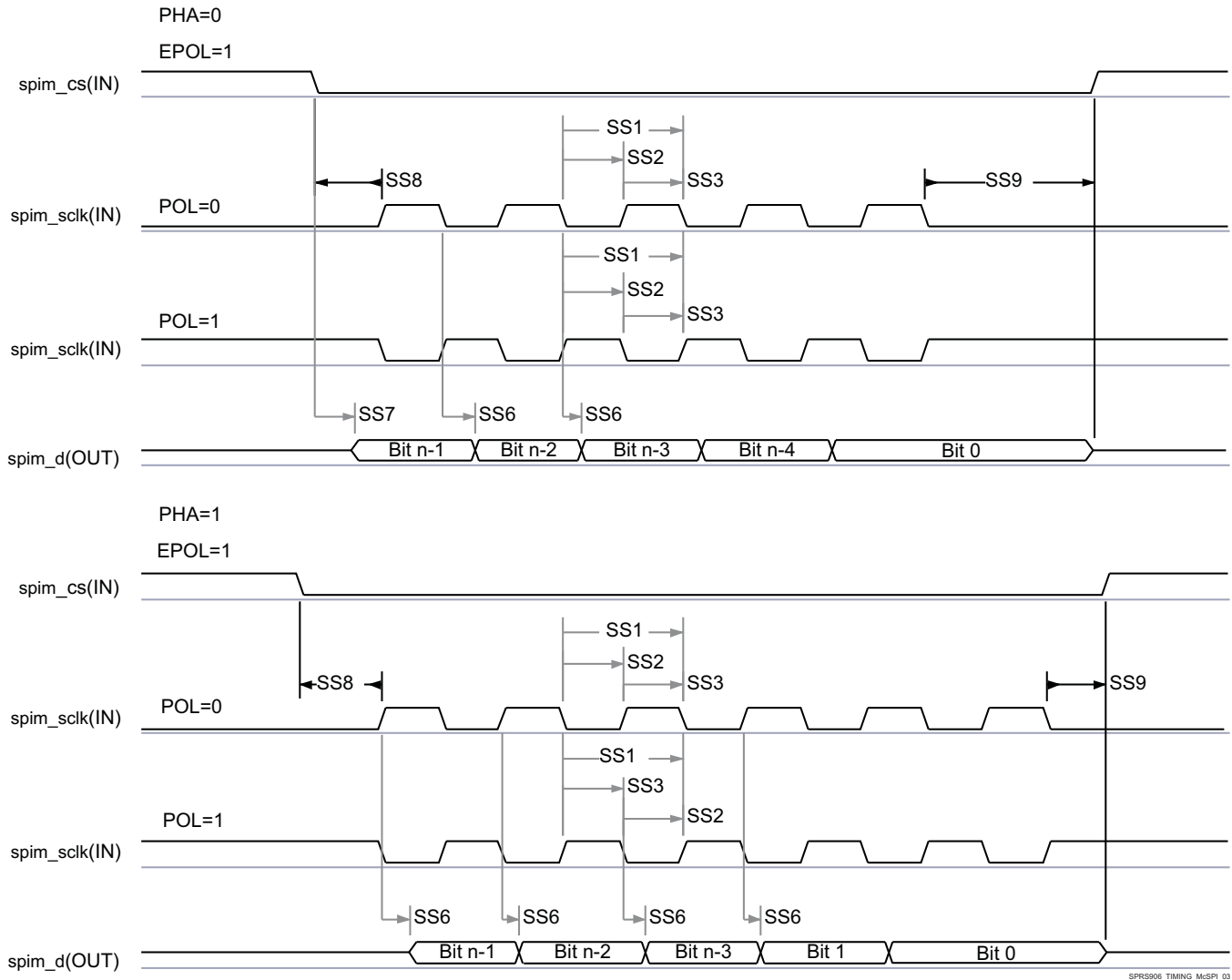
**Figure 5-52. McSPI - Slave Mode Transmit**

SPRS9806\_TIMING\_McSPI\_03



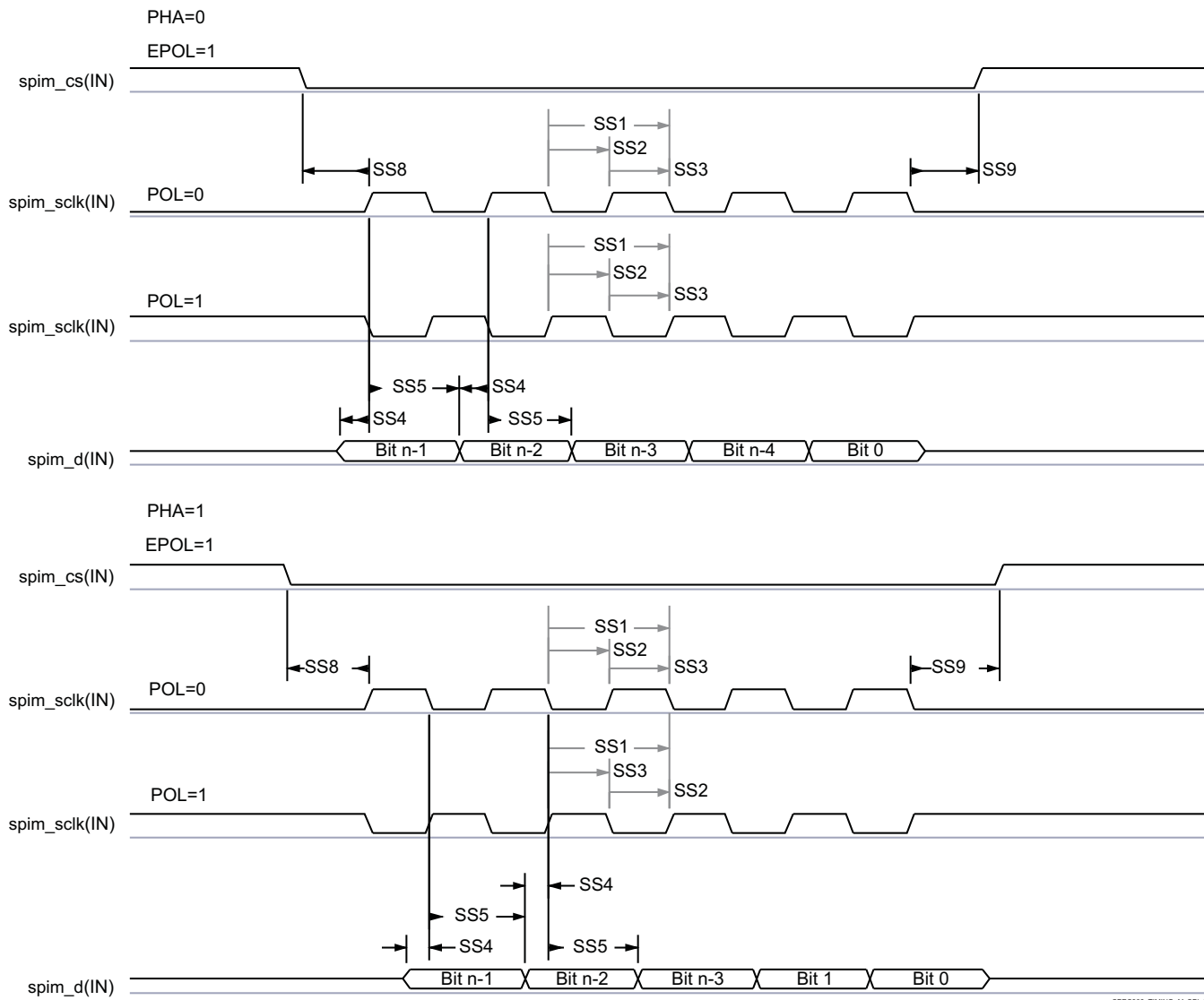

Figure 5-53. McSPI - Slave Mode Receive

In Table 5-76 are presented the specific groupings of signals (IOSET) for use with SPI3 and SPI4.

Table 5-76. McSPI3/4 IOSETs

Signal	IOSET1		IOSET2		IOSET3		IOSET4		IOSET5		IOSET6	
	BALL	MUX	BALL	MUX	BALL	MUX	BALL	MUX	BALL	MUX	BALL	MUX
<b>SPI3</b>												
spi3_sclk	AD9	8	E11	8	V2	7	B12	3	C18	2	AC4	1
spi3_d1	AF9	8	B10	8	Y1	7	A11	3	A21	2	AC7	1
spi3_d0	AE9	8	C11	8	W9	7	B13	3	G16	2	AC6	1
spi3_cs0	AF8	8	D11	8	V9	7	A12	3	D17	2	AC9	1
spi3_cs1	AC3	1	B11	8	AC3	1	E14	3	B11	8	AC3	1
spi3_cs2	-	-	F11	8	-	-	F11	8	F11	8	-	-
spi3_cs3	-	-	A10	8	-	-	A10	8	A10	8	-	-
<b>SPI4</b>												
spi4_sclk	N7	8	G1	8	V7	7	AA3	2	AC8	1	-	-

**Table 5-76. McSPI3/4 IOSETs (continued)**

Signal	IOSET1		IOSET2		IOSET3		IOSET4		IOSET5		IOSET6	
	BALL	MUX	BALL	MUX	BALL	MUX	BALL	MUX	BALL	MUX	BALL	MUX
spi4_d1	R4	8	G6	8	U7	7	AB9	2	AD6	1	-	-
spi4_d0	N9	8	F2	8	V6	7	AB3	2	AB8	1	-	-
spi4_cs0	P9	8	F3	8	U6	7	AA4	2	AB5	1	-	-
spi4_cs1	P4	8	P4	8	Y1	8	Y1	8	Y1	8	-	-
spi4_cs2	R3	8	R3	8	W9	8	W9	8	W9	8	-	-
spi4_cs3	T2	8	T2	8	V9	8	V9	8	V9	8	-	-

**5.10.6.12 QSPI**

The Quad SPI (QSPI) module is a type of SPI module that allows single, dual or quad read access to external SPI devices. This module has a memory mapped register interface, which provides a direct interface for accessing data from external SPI devices and thus simplifying software requirements. It works as a master only. There is one QSPI module in the device and it is primary intended for fast booting from quad-SPI flash memories.

General SPI features:

- Programmable clock divider
- Six pin interface (DCLK, CS\_N, DOUT, DIN, QDIN1, QDIN2)
- 4 external chip select signals
- Support for 3-, 4- or 6-pin SPI interface
- Programmable CS\_N to DOUT delay from 0 to 3 DCLKs
- Programmable signal polarities
- Programmable active clock edge
- Software controllable interface allowing for any type of SPI transfer

**NOTE**

For more information, see *Quad Serial Peripheral Interface* section in the device TRM.

**CAUTION**

The IO Timings provided in this section are only valid for some QSPI usage modes when the corresponding Virtual IO Timings or Manual IO Timings are configured as described in the tables found in this section.

**CAUTION**

The IO Timings provided in this section are only valid when all QSPI Chip Selects used in a system are configured to use the same Clock Mode (either Clock Mode 0 or Clock Mode3).

Table 5-77 and Table 5-78 present timing and switching characteristics for Quad SPI interface.

**Table 5-77. Switching Characteristics for QSPI**

No	PARAMETER	DESCRIPTION	Mode	MIN	MAX	UNIT
Q1	$t_{c(SCLK)}$	Cycle time, sclk	Manual IO Timing Modes, Clock Mode 0	10.41		ns
			Manual IO Timing Modes, Clock Mode 3	13.02		ns
			Bootmode, Clock Mode 3	20.8		
Q2	$t_{w(SCLKL)}$	Pulse duration, sclk low	All	$Y * P - 1$ <sup>(1)</sup>		ns
Q3	$t_{w(SCLKH)}$	Pulse duration, sclk high	All	$Y * P - 1$ <sup>(1)</sup>		ns
Q4	$t_{d(CS-SCLK)}$	Delay time, sclk falling edge to cs active edge, CS3:0	Manual IO Timing Modes	$-M * P - 1$ <sup>(2) (3)</sup>	$-M * P + 2$ <sup>(2) (3)</sup>	ns
			Bootmode	$-M * P - 2.5$ <sup>(2) (3)</sup>	$-M * P + 2.5$ <sup>(2) (3)</sup>	
Q5	$t_{d(SCLK-CS)}$	Delay time, sclk falling edge to cs inactive edge, CS3:0	Manual IO Timing Modes	$N * P - 1$ <sup>(2) (3)</sup>	$N * P + 2$ <sup>(2) (3)</sup>	ns
			Bootmode	$N * P - 2.5$ <sup>(2) (3)</sup>	$N * P + 2.5$ <sup>(2) (3)</sup>	
Q6	$t_{d(SCLK-D1)}$	Delay time, sclk falling edge to d[0] transition	Manual IO Timing Modes	-1	2	ns
			Bootmode	-2.5	2.5	
Q7	$t_{ena(CS-D1LZ)}$	Enable time, cs active edge to d[0] driven (lo-z)	All	-P-3.5	-P+2.5	ns
Q8	$t_{dis(CS-D1Z)}$	Disable time, cs active edge to d[0] tri-stated (hi-z)	All	-P-2.5	-P+2.0	ns
Q9	$t_{d(SCLK-D0)}$	Delay time, sclk first falling edge to first d[0] transition	Manual IO Timing Modes, PHA=0 Only	-1-P	2-P	ns
			Bootmode, PHA=0 Only	-2.5-P	2.5-P	

(1) The Y parameter is defined as follows:

If DCLK\_DIV is 0 or ODD then, Y equals 0.5.

If DCLK\_DIV is EVEN then, Y equals  $(DCLK\_DIV / 2) / (DCLK\_DIV + 1)$ .

For best performance, it is recommended to use a DCLK\_DIV of 0 or ODD to minimize the duty cycle distortion. The HSDIVIDER on CLKOUTX2\_H13 output of DPLL\_PER can be used to achieve the desired clock divider ratio. All required details about clock division factor DCLK\_DIV can be found in the Device TRM.

(2) P = SCLK period.

(3) M = QSPI\_SPI\_DC\_REG.DDx + 1 when Clock Mode 0.

M = QSPI\_SPI\_DC\_REG.DDx when Clock Mode 3.

N = 2 when Clock Mode 0.

N = 3 when Clock Mode 3.

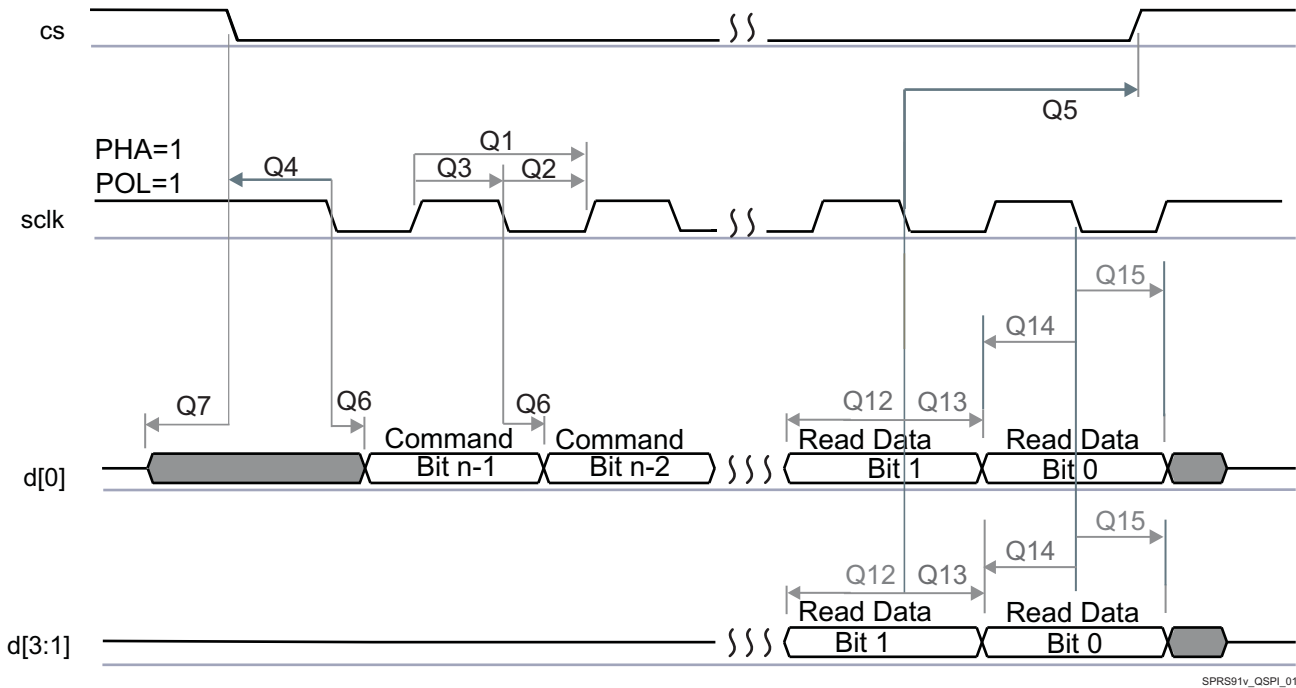

Figure 5-54. QSPI Read (Clock Mode 3)

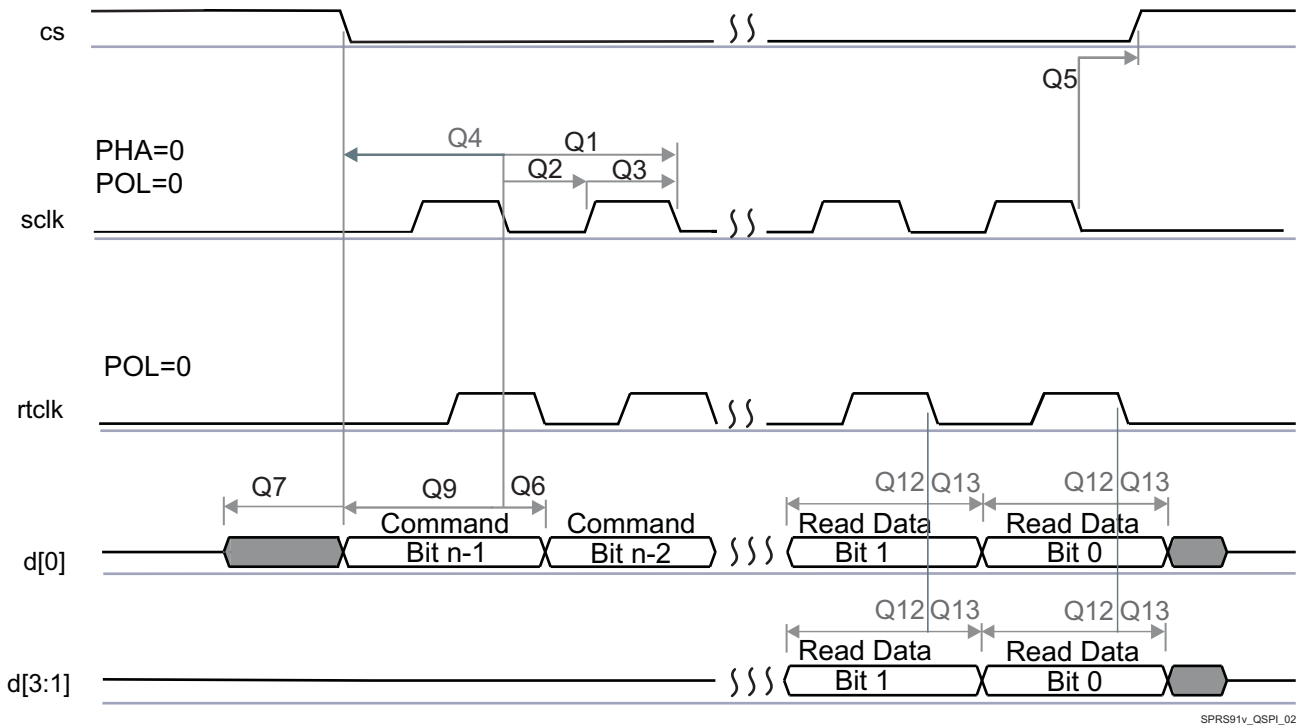

Figure 5-55. QSPI Read (Clock Mode 0)

**CAUTION**

The IO Timings provided in this section are only valid for some QSPI usage modes when the corresponding Virtual IO Timings or Manual IO Timings are configured as described in the tables found in this section.

**Table 5-78. Timing Requirements for QSPI<sup>(2)(3)</sup>**

No	PARAMETER	DESCRIPTION	Mode	MIN	MAX	UNIT
Q12	$t_{su}(D-RTCLK)$	Setup time, d[3:0] valid before falling rtclk edge	Manual IO Timing Modes, Clock Mode 0	2.9		ns
	$t_{su}(D-SCLK)$	Setup time, d[3:0] valid before falling sclk edge	Manual IO Timing Modes, Clock Mode 3	5.7		ns
			Boot Mode, Clock Mode 3	12.3		ns
Q13	$t_h(RTCLK-D)$	Hold time, d[3:0] valid after falling rtclk edge	Manual IO Timing Mode, Clock Mode 0	-0.1		ns
	$t_h(SCLK-D)$	Hold time, d[3:0] valid after falling sclk edge	Manual IO Timing Mode, Clock Mode 3	0.1		ns
			Boot Mode, Clock Mode 3	0.1		ns
Q14	$t_{su}(D-SCLK)$	Setup time, final d[3:0] bit valid before final falling sclk edge	Manual IO Timing Mode, Clock Mode 3	5.7-P <sup>(1)</sup>		ns
			Boot Mode, Clock Mode 3	12.3-P <sup>(1)</sup>		ns
Q15	$t_h(SCLK-D)$	Hold time, final d[3:0] bit valid after final falling sclk edge	Manual IO Timing Mode, Clock Mode 3	0.1+P <sup>(1)</sup>		ns
			Boot Mode, Clock Mode 3	0.1+P <sup>(1)</sup>		ns

(1) P = SCLK period.

(2) Clock Modes 1 and 2 are not supported.

(3) The Device captures data on the falling clock edge in Clock Mode 0 and 3, as opposed to the traditional rising clock edge. Although non-standard, the falling-edge-based setup and hold time timings have been designed to be compatible with standard SPI devices that launch data on the falling edge in Clock Modes 0 and 3.

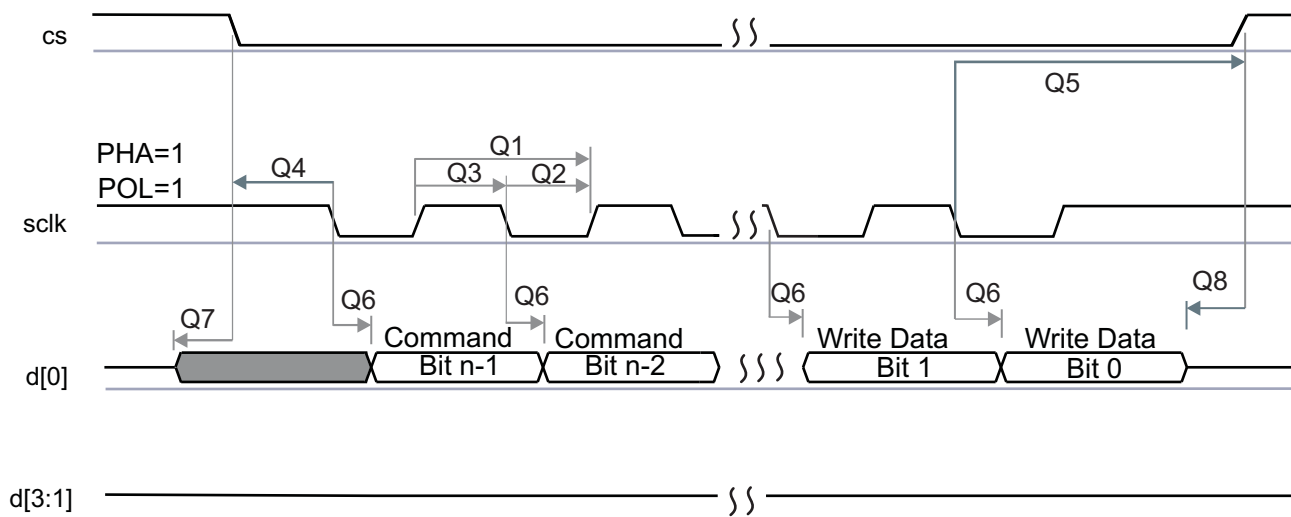

SPRS91v\_QSPI\_03

**Figure 5-56. QSPI Write (Clock Mode 3)**

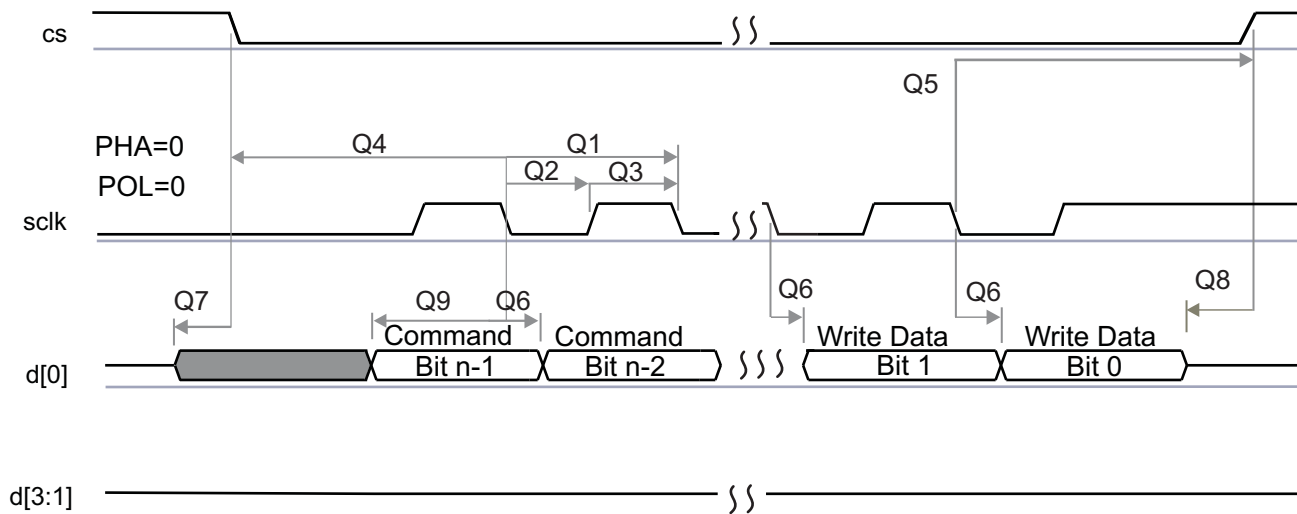

SPRS91v\_QSPI\_04

**Figure 5-57. QSPI Write (Clock Mode 0)**

**NOTE**

To configure the desired manual IO timing mode the user must follow the steps described in *Manual IO Timing Modes* section in the device TRM.

The associated registers to configure are listed in the **CFG REGISTER** column. For more information, see *Control Module* chapter in the device TRM.

Manual IO Timings Modes must be used to ensure some IO timings for QSPI. See [Table 5-33, Modes Summary](#) for a list of IO timings requiring the use of Manual IO Timings Modes. See [Table 5-79, Manual Functions Mapping for QSPI](#) for a definition of the Manual modes.

[Table 5-79](#) lists the A\_DELAY and G\_DELAY values needed to calculate the correct values to be set in the CFG\_x registers.

**Table 5-79. Manual Functions Mapping for QSPI**

BALL	BALL NAME	QSPI_MODE0_MANUAL1		QSPI_MODE3_MANUAL1		CFG REGISTER	MUXMODE
		A_DELAY (ps)	G_DELAY (ps)	A_DELAY (ps)	G_DELAY (ps)		1
R3	gpmc_a13	0	0	0	0	CFG_GPMC_A13_IN	qspi1_rclk
T2	gpmc_a14	2149	1052	0	0	CFG_GPMC_A14_IN	qspi1_d3
U2	gpmc_a15	2121	997	0	0	CFG_GPMC_A15_IN	qspi1_d2
U1	gpmc_a16	2159	1134	0	0	CFG_GPMC_A16_IN	qspi1_d0
U1	gpmc_a16	0	0	0	0	CFG_GPMC_A16_OUT	qspi1_d0
P3	gpmc_a17	2135	1085	0	0	CFG_GPMC_A17_IN	qspi1_d1
R2	gpmc_a18	0	0	151	0	CFG_GPMC_A18_OUT	qspi1_sclk
T7	gpmc_a3	0	0	0	0	CFG_GPMC_A3_OUT	qspi1_cs2
P6	gpmc_a4	0	0	0	0	CFG_GPMC_A4_OUT	qspi1_cs3
P2	gpmc_cs2	0	0	0	0	CFG_GPMC_CS2_OUT	qspi1_cs0
P1	gpmc_cs3	0	0	22	0	CFG_GPMC_CS3_OUT	qspi1_cs1

**5.10.6.13 McASP**

The multichannel audio serial port (McASP) functions as a general-purpose audio serial port optimized for the needs of multichannel audio applications. The McASP is useful for time-division multiplexed (TDM) stream, Inter-Integrated Sound (I2S) protocols, and inter-component digital audio interface transmission (DIT).

The device have integrated 8 McASP modules (McASP1-McASP8) with:

- McASP1 and McASP2 modules supporting 16 channels with independent TX/RX clock/sync domain
- McASP3 through McASP8 modules supporting 4 channels with independent TX/RX clock/sync domain

**NOTE**

For more information, see *Multichannel Audio Serial Port* section in the device TRM.

**CAUTION**

The IO Timings provided in this section are only valid for some McASP usage modes when the corresponding Virtual IO Timings or Manual IO Timings are configured as described in the tables found in this section.

Table 5-80, Table 5-81, Table 5-82, and Figure 5-58 present Timing Requirements for McASP1 to McASP8.

**Table 5-80. Timing Requirements for McASP1 <sup>(1)</sup>**

NO.	PARAMETER	DESCRIPTION	MODE	MIN	MAX	UNIT
ASP1	$t_{c(AHCLKX)}$	Cycle time, AHCLKX		20		ns
ASP2	$t_{w(AHCLKX)}$	Pulse duration, AHCLKX high or low		0.35P <sup>(2)</sup>		ns
ASP3	$t_{c(ACLKR/X)}$	Cycle time, ACLKR/X		20		ns
ASP4	$t_{w(ACLKR/X)}$	Pulse duration, ACLKR/X high or low		0.5R <sup>(3)</sup> - 3		ns
ASP5	$t_{su(AFSRX-ACLK)}$	Setup time, AFSRX input valid before ACLKR/X	ACLKR/X int	20		ns
			ACLKR/X ext in ACLKR/X ext out	4		ns
ASP6	$t_{h(ACLK-AFSRX)}$	Hold time, AFSRX input valid after ACLKR/X	ACLKR/X int	-1		ns
			ACLKR/X ext in ACLKR/X ext out	2.21		ns
ASP7	$t_{su(AXR-ACLK)}$	Setup time, AXR input valid before ACLKR/X	ACLKR/X int	21.9		ns
			ACLKR/X ext in ACLKR/X ext out	4.42		ns
ASP8	$t_{h(ACLK-AXR)}$	Hold time, AXR input valid after ACLKR/X	ACLKR/X int	-1		ns
			ACLKR/X ext in ACLKR/X ext out	2.52		ns

- (1) ACLKR internal: ACLKRCTL.CLKRM = 1, PDIR.ACLKR = 1  
 ACLKR external input: ACLKRCTL.CLKRM = 0, PDIR.ACLKR = 0  
 ACLKR external output: ACLKRCTL.CLKRM = 0, PDIR.ACLKR = 1  
 ACLKX internal: ACLKXCTL.CLKXM = 1, PDIR.ACLKX = 1  
 ACLKX external input: ACLKXCTL.CLKXM = 0, PDIR.ACLKX = 0  
 ACLKX external output: ACLKXCTL.CLKXM = 0, PDIR.ACLKX = 1

(2) P = AHCLKX period in ns.

(3) R = ACLKR/X period in ns.

**Table 5-81. Timing Requirements for McASP2 <sup>(1)</sup>**

NO.	PARAMETER	DESCRIPTION	MODE	MIN	MAX	UNIT
ASP1	$t_{c(AHCLKX)}$	Cycle time, AHCLKX		20		ns
ASP2	$t_{w(AHCLKX)}$	Pulse duration, AHCLKX high or low		0.35P <sup>(2)</sup>		ns
ASP3	$t_{c(ACLKR/X)}$	Cycle time, ACLKR/X	Any Other Conditions	20		ns
			ACLKX/AFSX (In Sync Mode), ACLKR/AFSR (In Async Mode), and AXR are all inputs "80M" Virtual IO Timing Mode	12.5		ns
ASP4	$t_{w(ACLKR/X)}$	Pulse duration, ACLKR/X high or low	Any Other Conditions	0.5R <sup>(3)</sup> - 3		ns
			ACLKX/AFSX (In Sync Mode), ACLKR/AFSR (In Async Mode), and AXR are all inputs "80M" Virtual IO Timing Modes	0.38R <sup>(3)</sup>		ns
ASP5	$t_{su(AFSRX-ACLK)}$	Setup time, AFSRX input valid before ACLKR/X	ACLKR/X int	20.7		ns
			ACLKR/X ext in ACLKR/X ext out	3.9		ns
			ACLKR/X ext in ACLKR/X ext out "80M" Virtual IO Timing Modes	3		ns
ASP6	$t_{h(ACLK-AFSRX)}$	Hold time, AFSRX input valid after ACLKR/X	ACLKR/X int	-1		ns
			ACLKR/X ext in ACLKR/X ext out	3.2		ns
			ACLKR/X ext in ACLKR/X ext out "80M" Virtual IO Timing Modes	3		ns



**Table 5-81. Timing Requirements for McASP2 <sup>(1)</sup> (continued)**

NO.	PARAMETER	DESCRIPTION	MODE	MIN	MAX	UNIT
ASP7	$t_{su}(AXR-ACLK)$	Setup time, AXR input valid before ACLKR/X	ACLKR/X int	21.4		ns
			ACLKR/X ext in ACLKR/X ext out	3.9		ns
			ACLKR/X ext in ACLKR/X ext out "80M" Virtual IO Timing Modes	3		ns
ASP8	$t_h(ACLK-AXR)$	Hold time, AXR input valid after ACLKR/X	ACLKR/X int	-1		ns
			ACLKR/X ext in ACLKR/X ext out	3.2		ns
			ACLKR/X ext in ACLKR/X ext out "80M" Virtual IO Timing Modes	3		ns

- (1) ACLKR internal: ACLKRCTL.CLKRM = 1, PDIR.ACLKR = 1  
 ACLKR external input: ACLKRCTL.CLKRM = 0, PDIR.ACLKR = 0  
 ACLKR external output: ACLKRCTL.CLKRM = 0, PDIR.ACLKR = 1  
 ACLKX internal: ACLKXCTL.CLKXM = 1, PDIR.ACLKX = 1  
 ACLKX external input: ACLKXCTL.CLKXM = 0, PDIR.ACLKX = 0  
 ACLKX external output: ACLKXCTL.CLKXM = 0, PDIR.ACLKX = 1

- (2) P = AHCLKX period in ns.  
 (3) R = ACLKR/X period in ns.

**Table 5-82. Timing Requirements for McASP3/4/5/6/7/8 <sup>(1)</sup>**

NO.	PARAMETER	DESCRIPTION	MODE	MIN	MAX	UNIT
ASP1	$t_c(AHCLKX)$	Cycle time, AHCLKX		20		ns
ASP2	$t_w(AHCLKX)$	Pulse duration, AHCLKX high or low		0.35P <sup>(2)</sup>		ns
ASP3	$t_c(ACLKRX)$	Cycle time, ACLKR/X		20		ns
ASP4	$t_w(ACLKRX)$	Pulse duration, ACLKR/X high or low		0.5R <sup>(3)</sup> - 3		ns
ASP5	$t_{su}(AFSRX-ACLK)$	Setup time, AFSRX input valid before ACLKR/X	ACLKR/X int	20.2		ns
			ACLKR/X ext in ACLKR/X ext out	4.9		ns
ASP6	$t_h(ACLK-AFSRX)$	Hold time, AFSRX input valid after ACLKR/X	ACLKR/X int	-1		ns
			ACLKR/X ext in ACLKR/X ext out	2.26		ns
ASP7	$t_{su}(AXR-ACLK)$	Setup time, AXR input valid before ACLKX	ACLKX int (ASYNC=0)	20.8		ns
			ACLKR/X ext in ACLKR/X ext out	5.75		ns
ASP8	$t_h(ACLK-AXR)$	Hold time, AXR input valid after ACLKX	ACLKX int (ASYNC=0)	-0.9		ns
			ACLKR/X ext in ACLKR/X ext out	2.87		ns

- (1) ACLKR internal: ACLKRCTL.CLKRM = 1, PDIR.ACLKR = 1 (NOT SUPPORTED)  
 ACLKR external input: ACLKRCTL.CLKRM = 0, PDIR.ACLKR = 0  
 ACLKR external output: ACLKRCTL.CLKRM = 0, PDIR.ACLKR = 1  
 ACLKX internal: ACLKXCTL.CLKXM = 1, PDIR.ACLKX = 1  
 ACLKX external input: ACLKXCTL.CLKXM = 0, PDIR.ACLKX = 0  
 ACLKX external output: ACLKXCTL.CLKXM = 0, PDIR.ACLKX = 1

- (2) P = AHCLKX period in ns.  
 (3) R = ACLKR/X period in ns.

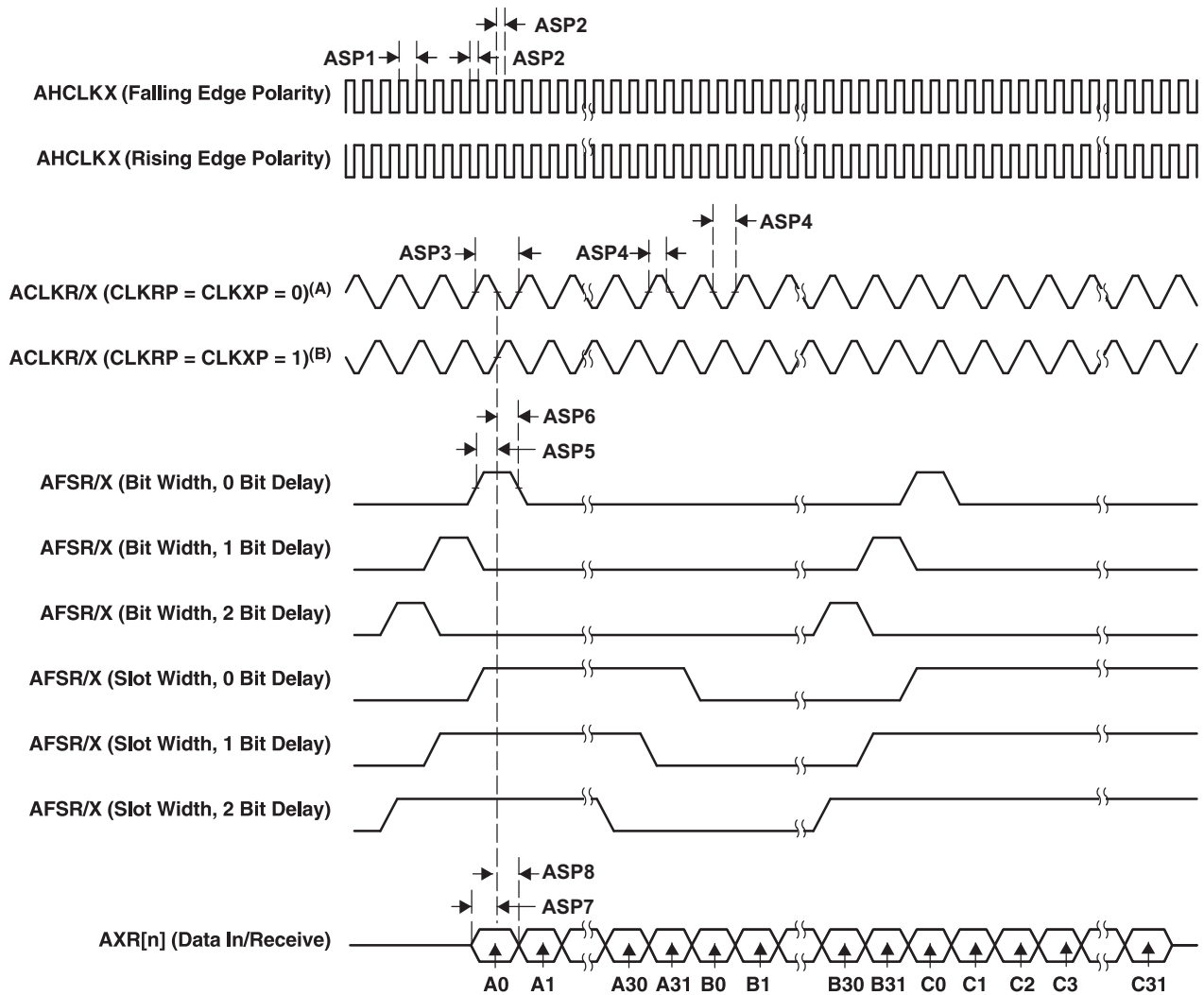

- A. For CLKRP = CLKXP = 0, the McASP transmitter is configured for rising edge (to shift data out) and the McASP receiver is configured for falling edge (to shift data in).
- B. For CLKRP = CLKXP = 1, the McASP transmitter is configured for falling edge (to shift data out) and the McASP receiver is configured for rising edge (to shift data in).

**Figure 5-58. McASP Input Timing**

**CAUTION**

The IO Timings provided in this section are only valid for some McASP usage modes when the corresponding Virtual IO Timings or Manual IO Timings are configured as described in the tables found in this section.

Table 5-83, Table 5-84, Table 5-85, and Figure 5-59 present Switching Characteristics Over Recommended Operating Conditions for McASP1 to McASP8.

**Table 5-83. Switching Characteristics Over Recommended Operating Conditions for McASP1 <sup>(1)</sup>**

NO.	PARAMETER	DESCRIPTION	MODE	MIN	MAX	UNIT
ASP9	$t_{c(AHCLKX)}$	Cycle time, AHCLKX		20		ns
ASP10	$t_{w(AHCLKX)}$	Pulse duration, AHCLKX high or low		0.5P - 2.5 <sup>(2)</sup>		ns

**Table 5-83. Switching Characteristics Over Recommended Operating Conditions for McASP1**  
<sup>(1)</sup> (continued)

NO.	PARAMETER	DESCRIPTION	MODE	MIN	MAX	UNIT
ASP11	$t_{c(ACLKR/X)}$	Cycle time, ACLKR/X		20		ns
ASP12	$t_{w(ACLKR/X)}$	Pulse duration, ACLKR/X high or low		0.5R <sup>(3)</sup> - 2.5		ns
ASP13	$t_{d(ACLK-AFSXR)}$	Delay time, ACLKR/X transmit edge to AFSX/R output valid	ACLKR/X int	-0.21	6	ns
			ACLKR/X ext in ACLKR/X ext out	2	23.9	ns
ASP14	$t_{d(ACLK-AXR)}$	Delay time, ACLKR/X transmit edge to AXR output valid	ACLKR/X int	-1.8	6.9	ns
			ACLKR/X ext in ACLKR/X ext out	2	25.6	ns

- (1) ACLKR internal: ACLKRCTL.CLKRM = 1, PDIR.ACLKR = 1  
 ACLKR external input: ACLKRCTL.CLKRM = 0, PDIR.ACLKR = 0  
 ACLKR external output: ACLKRCTL.CLKRM = 0, PDIR.ACLKR = 1  
 ACLKX internal: ACLKXCTL.CLKXM = 1, PDIR.ACLKX = 1  
 ACLKX external input: ACLKXCTL.CLKXM = 0, PDIR.ACLKX = 0  
 ACLKX external output: ACLKXCTL.CLKXM = 0, PDIR.ACLKX = 1

- (2) P = AHCLKX period in ns.  
 (3) R = ACLKR/X period in ns.

**Table 5-84. Switching Characteristics Over Recommended Operating Conditions for McASP2** <sup>(1)</sup>

NO.	PARAMETER	DESCRIPTION	MODE	MIN	MAX	UNIT
ASP9	$t_{c(AHCLKX)}$	Cycle time, AHCLKX		20		ns
ASP10	$t_{w(AHCLKX)}$	Pulse duration, AHCLKX high or low		0.5P - 2.5 <sup>(2)</sup>		ns
ASP11	$t_{c(ACLKR/X)}$	Cycle time, ACLKR/X		20		ns
ASP12	$t_{w(ACLKR/X)}$	Pulse duration, ACLKR/X high or low		0.5R <sup>(3)</sup> - 2.5		ns
ASP13	$t_{d(ACLK-AFSXR)}$	Delay time, ACLKR/X transmit edge to AFSX/R output valid	ACLKR/X int	0	6	ns
			ACLKR/X ext in ACLKR/X ext out	2	25.2	ns
ASP14	$t_{d(ACLK-AXR)}$	Delay time, ACLKR/X transmit edge to AXR output valid	ACLKR/X int	-1.29	6.11	ns
			ACLKR/X ext in ACLKR/X ext out	2	24.8	ns

- (1) ACLKR internal: ACLKRCTL.CLKRM = 1, PDIR.ACLKR = 1  
 ACLKR external input: ACLKRCTL.CLKRM = 0, PDIR.ACLKR = 0  
 ACLKR external output: ACLKRCTL.CLKRM = 0, PDIR.ACLKR = 1  
 ACLKX internal: ACLKXCTL.CLKXM = 1, PDIR.ACLKX = 1  
 ACLKX external input: ACLKXCTL.CLKXM = 0, PDIR.ACLKX = 0  
 ACLKX external output: ACLKXCTL.CLKXM = 0, PDIR.ACLKX = 1

- (2) P = AHCLKX period in ns.  
 (3) R = ACLKR/X period in ns.

**Table 5-85. Switching Characteristics Over Recommended Operating Conditions for McASP3/4/5/6/7/8** <sup>(1)</sup>

NO.	PARAMETER	DESCRIPTION	MODE	MIN	MAX	UNIT
ASP9	$t_{c(AHCLKX)}$	Cycle time, AHCLKX		20		ns
ASP10	$t_{w(AHCLKX)}$	Pulse duration, AHCLKX high or low		0.5P - 2.5 <sup>(2)</sup>		ns
ASP11	$t_{c(ACLKR/X)}$	Cycle time, ACLKR/X		20		ns
ASP12	$t_{w(ACLKR/X)}$	Pulse duration, ACLKR/X high or low		0.5R <sup>(3)</sup> - 2.5		ns
ASP13	$t_{d(ACLK-AFSXR)}$	Delay time, ACLKR/X transmit edge to AFSX/R output valid	ACLKR/X int	-0.74	6	ns
			ACLKR/X ext in ACLKR/X ext out	2	26.4	ns

**Table 5-85. Switching Characteristics Over Recommended Operating Conditions for McASP3/4/5/6/7/8**  
(1) (continued)

NO.	PARAMETER	DESCRIPTION	MODE	MIN	MAX	UNIT
ASP14	$t_{d(ACLK-AXR)}$	Delay time, ACLKR/X transmit edge to AXR output valid	ACLKR/X int	-1.68	6.97	ns
			ACLKR/X ext in ACLKR/X ext out	1.07	25.9	ns

- (1) ACLKR internal: ACLKRCTL.CLKRM = 1, PDIR.ACLKR = 1  
 ACLKR external input: ACLKRCTL.CLKRM = 0, PDIR.ACLKR = 0  
 ACLKR external output: ACLKRCTL.CLKRM = 0, PDIR.ACLKR = 1  
 ACLKX internal: ACLKXCTL.CLKXM = 1, PDIR.ACLKX = 1  
 ACLKX external input: ACLKXCTL.CLKXM = 0, PDIR.ACLKX = 0  
 ACLKX external output: ACLKXCTL.CLKXM = 0, PDIR.ACLKX = 1
- (2) P = AHCLKX period in ns.
- (3) R = ACLKR/X period in ns.

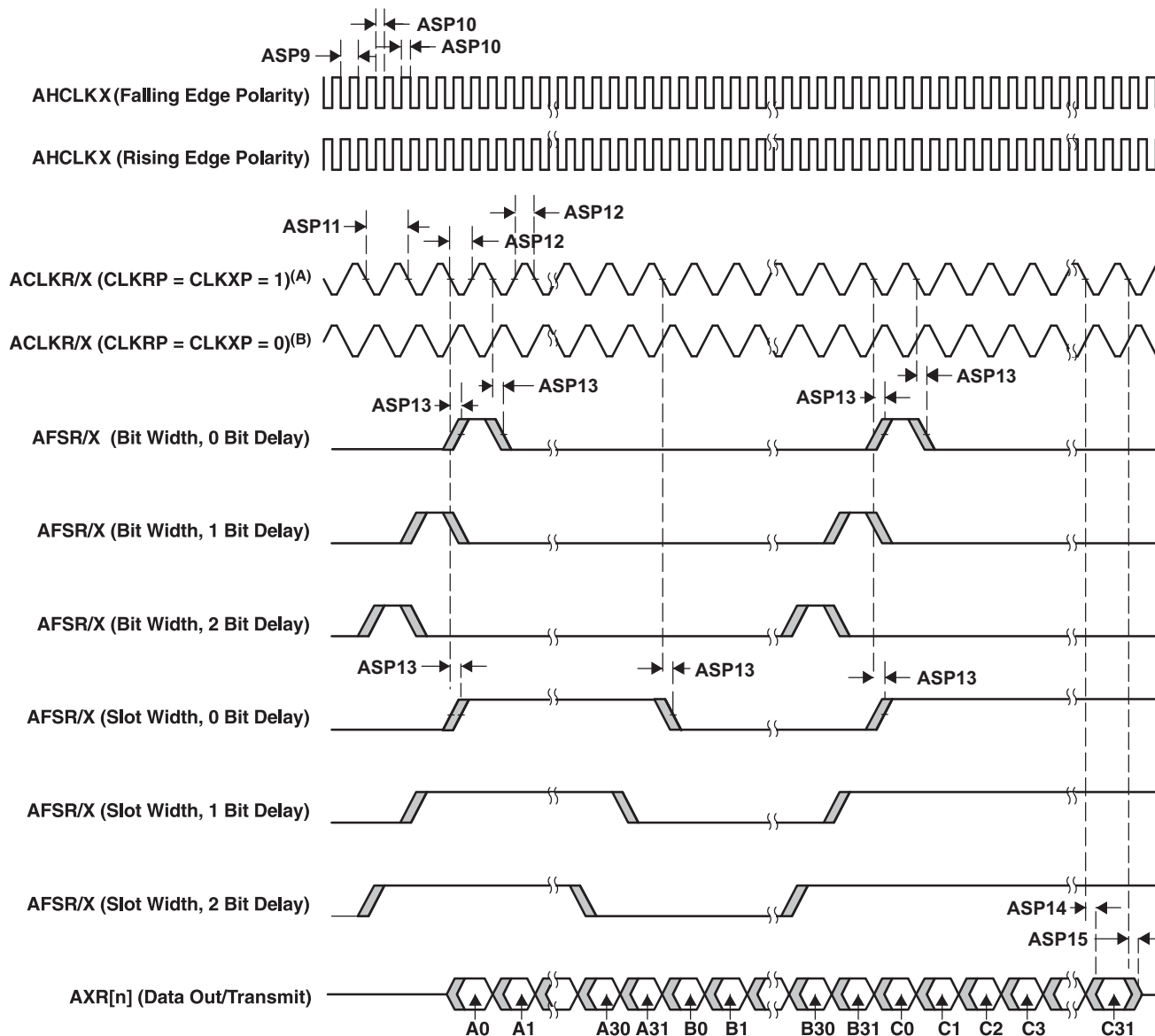

- A. For CLKRP = CLKXP = 1, the McASP transmitter is configured for falling edge (to shift data out) and the McASP receiver is configured for rising edge (to shift data in).
- B. For CLKRP = CLKXP = 0, the McASP transmitter is configured for rising edge (to shift data out) and the McASP receiver is configured for falling edge (to shift data in).

**Figure 5-59. McASP Output Timing**

**NOTE**

To configure the desired virtual mode the user must set MODESELECT bit and DELAYMODE bit field for each corresponding pad control register.

The pad control registers are presented in [Table 4-33](#) and described in chapter Control Module in the device TRM.

[Table 5-86](#) through [Table 5-93](#) explain all cases with Virtual Mode Details for McASP1/2/3/4/5/6/7/8 (see [Figure 5-60](#) through [Figure 5-67](#)).

**Table 5-86. Virtual Mode Case Details for McASP1**

No.	CASE	CASE Description	Virtual Mode Settings		Notes
			Signals	Virtual Mode Value	
<b>IP Mode : ASYNC</b>					
1	COIFOI	CLKX / FSX: Output CLKR / FSR: Input	AXR(Outputs)/CLKX/FSX	Default (No Virtual Mode)	See <a href="#">Figure 5-60</a>
			AXR(Inputs)/CLKR/FSR	MCASP1_VIRTUAL3_ASYNC_RX	
2	COIFIO	CLKX / FSR: Output CLKR / FSX: Input	AXR(Outputs)/CLKX/FSX	Default (No Virtual Mode)	See <a href="#">Figure 5-61</a>
			AXR(Inputs)/CLKR/FSR	MCASP1_VIRTUAL3_ASYNC_RX	
3	CIOFIO	CLKR / FSR: Output CLKX / FSX: Input	AXR(Outputs)/CLKX/FSX	MCASP1_VIRTUAL3_ASYNC_RX	See <a href="#">Figure 5-62</a>
			AXR(Inputs)/CLKR/FSR	MCASP1_VIRTUAL1_ASYNC_TX	
4	CIOFOI	CLKR / FSX: Output CLKX / FSR: Input	AXR(Outputs)/CLKX/FSX	MCASP1_VIRTUAL3_ASYNC_RX	See <a href="#">Figure 5-63</a>
			AXR(Inputs)/CLKR/FSR	MCASP1_VIRTUAL1_ASYNC_TX	
<b>IP Mode : SYNC (CLKR / FSR internally generated from CLKX / FSX)</b>					
5	CO-FO-	CLKX / FSX: Output	AXR(Outputs)/CLKX/FSX	Default (No Virtual Mode)	See <a href="#">Figure 5-64</a>
			AXR(Inputs)/CLKX/FSX	Default (No Virtual Mode)	
6	CI-FO-	FSX: Output CLKX: Input	AXR(Outputs)/CLKX/FSX	MCASP1_VIRTUAL2_SYNC_RX	See <a href="#">Figure 5-65</a>
			AXR(Inputs)/CLKX/FSX	MCASP1_VIRTUAL2_SYNC_RX	
7	CI-FI-	CLKX / FSX: Input	AXR(Outputs)/CLKX/FSX	MCASP1_VIRTUAL2_SYNC_RX	See <a href="#">Figure 5-66</a>
			AXR(Inputs)/CLKX/FSX	MCASP1_VIRTUAL2_SYNC_RX	
8	CO-FI-	CLKX: Output FSX: Input	AXR(Outputs)/CLKX/FSX	Default (No Virtual Mode)	See <a href="#">Figure 5-67</a>
			AXR(Inputs)/CLKX/FSX	Default (No Virtual Mode)	

**Table 5-87. Virtual Mode Case Details for McASP2**

No.	CASE	CASE Description	Virtual Mode Settings		Notes
			Signals	Virtual Mode Value	
<b>IP Mode : ASYNC</b>					
1	COIFOI	CLKX / FSX: Output CLKR / FSR: Input	AXR(Outputs)/CLKX/FSX	Default (No Virtual Mode) <sup>(1)</sup>	See <a href="#">Figure 5-60</a>
			AXR(Inputs)/CLKR/FSR	Default (No Virtual Mode) <sup>(1)</sup>	
			AXR(Inputs)/CLKR/FSR	MCASP2_VIRTUAL1_ASYNC_RX_80M <sup>(2)</sup>	
2	COIFIO	CLKX / FSR: Output CLKR / FSX: Input	AXR(Outputs)/CLKX/FSX	Default (No Virtual Mode)	See <a href="#">Figure 5-61</a>
			AXR(Inputs)/CLKR/FSR	MCASP2_VIRTUAL2_ASYNC_RX	
3	CIOFIO	CLKR / FSR: Output CLKX / FSX: Input	AXR(Outputs)/CLKX/FSX	MCASP2_VIRTUAL2_ASYNC_RX	See <a href="#">Figure 5-62</a>
			AXR(Inputs)/CLKR/FSR	MCASP2_VIRTUAL3_ASYNC_TX	
4	CIOFOI	CLKR / FSX: Output CLKX / FSR: Input	AXR(Outputs)/CLKX/FSX	MCASP2_VIRTUAL2_ASYNC_RX	See <a href="#">Figure 5-63</a>
			AXR(Inputs)/CLKR/FSR	MCASP2_VIRTUAL3_ASYNC_TX	
<b>IP Mode : SYNC (CLKR / FSR internally generated from CLKX / FSX)</b>					
5	CO-FO-	CLKX / FSX: Output	AXR(Outputs)/CLKX/FSX	Default (No Virtual Mode)	See <a href="#">Figure 5-64</a>
			AXR(Inputs)/CLKX/FSX	Default (No Virtual Mode)	
6	CI-FO-	FSX: Output CLKX: Input	AXR(Outputs)/CLKX/FSX	MCASP2_VIRTUAL4_SYNC_RX	See <a href="#">Figure 5-65</a>
			AXR(Inputs)/CLKX/FSX	MCASP2_VIRTUAL4_SYNC_RX	
7	CI-FI-	CLKX / FSX: Input	AXR(Outputs)/CLKX/FSX	MCASP2_VIRTUAL4_SYNC_RX <sup>(1)</sup>	See <a href="#">Figure 5-66</a>
			AXR(Inputs)/CLKX/FSX	MCASP2_VIRTUAL4_SYNC_RX <sup>(1)</sup>	
			AXR(Inputs)/CLKX/FSX	MCASP2_VIRTUAL5_SYNC_RX_80M <sup>(2)</sup>	
8	CO-FI-	CLKX: Output FSX: Input	AXR(Outputs)/CLKX/FSX	Default (No Virtual Mode)	See <a href="#">Figure 5-67</a>
			AXR(Inputs)/CLKX/FSX	Default (No Virtual Mode)	

- (1) Used up to 50 MHz. Should also be used in a CI-FI- mixed case where AXR operate as both inputs and outputs (that is, AXR are bidirectional).
- (2) Used in 80 MHz input only mode when AXR, CLKX and FSX are all inputs.

**Table 5-88. Virtual Mode Case Details for McASP3**

No.	CASE	CASE Description	Virtual Mode Settings		Notes
			Signals	Virtual Mode Value	
<b>IP Mode : ASYNC</b>					
1	COIFOI	CLKX / FSX: Output CLKR / FSR: Input	AXR(Outputs)/CLKX/FSX	Default (No Virtual Mode)	See <a href="#">Figure 5-60</a>
			AXR(Inputs)/CLKR/FSR	MCASP3_VIRTUAL2_SYNC_RX	
2	COIFIO	CLKX / FSR: Output CLKR / FSX: Input	AXR(Outputs)/CLKX/FSX	Default (No Virtual Mode)	See <a href="#">Figure 5-61</a>
			AXR(Inputs)/CLKR/FSR	MCASP3_VIRTUAL2_SYNC_RX	
3	CIOFIO	CLKR / FSR: Output CLKX / FSX: Input	AXR(Outputs)/CLKX/FSX	MCASP3_VIRTUAL2_SYNC_RX	See <a href="#">Figure 5-62</a>
			AXR(Inputs)/CLKR/FSR	MCASP3_VIRTUAL2_SYNC_RX	
4	CIOFOI	CLKR / FSX: Output CLKX / FSR: Input	AXR(Outputs)/CLKX/FSX	MCASP3_VIRTUAL2_SYNC_RX	See <a href="#">Figure 5-63</a>
			AXR(Inputs)/CLKR/FSR	MCASP3_VIRTUAL2_SYNC_RX	
<b>IP Mode : SYNC (CLKR / FSR internally generated from CLKX / FSX)</b>					
5	CO-FO-	CLKX / FSX: Output	AXR(Outputs)/CLKX/FSX	Default (No Virtual Mode)	See <a href="#">Figure 5-64</a>
			AXR(Inputs)/CLKX/FSX	Default (No Virtual Mode)	
6	CI-FO-	FSX: Output CLKX: Input	AXR(Outputs)/CLKX/FSX	MCASP3_VIRTUAL2_SYNC_RX	See <a href="#">Figure 5-65</a>
			AXR(Inputs)/CLKX/FSX	MCASP3_VIRTUAL2_SYNC_RX	
7	CI-FI-	CLKX / FSX: Input	AXR(Outputs)/CLKX/FSX	MCASP3_VIRTUAL2_SYNC_RX	See <a href="#">Figure 5-66</a>
			AXR(Inputs)/CLKX/FSX	MCASP3_VIRTUAL2_SYNC_RX	
8	CO-FI-	CLKX: Output FSX: Input	AXR(Outputs)/CLKX/FSX	Default (No Virtual Mode)	See <a href="#">Figure 5-67</a>
			AXR(Inputs)/CLKX/FSX	Default (No Virtual Mode)	

**Table 5-89. Virtual Mode Case Details for McASP4**

No.	CASE	CASE Description	Virtual Mode Settings		Notes
			Signals	Virtual Mode Value	
<b>IP Mode : ASYNC</b>					
1	COIFOI	CLKX / FSX: Output CLKR / FSR: Input	AXR(Outputs)/CLKX/FSX	Default (No Virtual Mode)	See <a href="#">Figure 5-60</a>
			AXR(Inputs)/CLKR/FSR	MCASP4_VIRTUAL1_SYNC_RX	
2	COIFIO	CLKX / FSR: Output CLKR / FSX: Input	AXR(Outputs)/CLKX/FSX	Default (No Virtual Mode)	See <a href="#">Figure 5-61</a>
			AXR(Inputs)/CLKR/FSR	MCASP4_VIRTUAL1_SYNC_RX	
3	CIOFIO	CLKR / FSR: Output CLKX / FSX: Input	AXR(Outputs)/CLKX/FSX	MCASP4_VIRTUAL1_SYNC_RX	See <a href="#">Figure 5-62</a>
			AXR(Inputs)/CLKR/FSR	MCASP4_VIRTUAL1_SYNC_RX	
4	CIOFOI	CLKR / FSX: Output CLKX / FSR: Input	AXR(Outputs)/CLKX/FSX	MCASP4_VIRTUAL1_SYNC_RX	See <a href="#">Figure 5-63</a>
			AXR(Inputs)/CLKR/FSR	MCASP4_VIRTUAL1_SYNC_RX	
<b>IP Mode : SYNC (CLKR / FSR internally generated from CLKX / FSX)</b>					
5	CO-FO-	CLKX / FSX: Output	AXR(Outputs)/CLKX/FSX	Default (No Virtual Mode)	See <a href="#">Figure 5-64</a>
			AXR(Inputs)/CLKX/FSX	Default (No Virtual Mode)	
6	CI-FO-	FSX: Output CLKX: Input	AXR(Outputs)/CLKX/FSX	MCASP4_VIRTUAL1_SYNC_RX	See <a href="#">Figure 5-65</a>
			AXR(Inputs)/CLKX/FSX	MCASP4_VIRTUAL1_SYNC_RX	
7	CI-FI-	CLKX / FSX: Input	AXR(Outputs)/CLKX/FSX	MCASP4_VIRTUAL1_SYNC_RX	See <a href="#">Figure 5-66</a>
			AXR(Inputs)/CLKX/FSX	MCASP4_VIRTUAL1_SYNC_RX	
8	CO-FI-	CLKX: Output FSX: Input	AXR(Outputs)/CLKX/FSX	Default (No Virtual Mode)	See <a href="#">Figure 5-67</a>
			AXR(Inputs)/CLKX/FSX	Default (No Virtual Mode)	

**Table 5-90. Virtual Mode Case Details for McASP5**

No.	CASE	CASE Description	Virtual Mode Settings		Notes
			Signals	Virtual Mode Value	
<b>IP Mode : ASYNC</b>					
1	COIFOI	CLKX / FSX: Output CLKR / FSR: Input	AXR(Outputs)/CLKX/FSX	Default (No Virtual Mode)	See <a href="#">Figure 5-60</a>
			AXR(Inputs)/CLKR/FSR	MCASP5_VIRTUAL1_SYNC_RX	
2	COIFIO	CLKX / FSR: Output CLKR / FSX: Input	AXR(Outputs)/CLKX/FSX	Default (No Virtual Mode)	See <a href="#">Figure 5-61</a>
			AXR(Inputs)/CLKR/FSR	MCASP5_VIRTUAL1_SYNC_RX	
3	CIOFIO	CLKR / FSR: Output CLKX / FSX: Input	AXR(Outputs)/CLKX/FSX	MCASP5_VIRTUAL1_SYNC_RX	See <a href="#">Figure 5-62</a>
			AXR(Inputs)/CLKR/FSR	MCASP5_VIRTUAL1_SYNC_RX	
4	CIOFOI	CLKR / FSX: Output CLKX / FSR: Input	AXR(Outputs)/CLKX/FSX	MCASP5_VIRTUAL1_SYNC_RX	See <a href="#">Figure 5-63</a>
			AXR(Inputs)/CLKR/FSR	MCASP5_VIRTUAL1_SYNC_RX	
<b>IP Mode : SYNC (CLKR / FSR internally generated from CLKX / FSX)</b>					
5	CO-FO-	CLKX / FSX: Output	AXR(Outputs)/CLKX/FSX	Default (No Virtual Mode)	See <a href="#">Figure 5-64</a>
			AXR(Inputs)/CLKX/FSX	Default (No Virtual Mode)	
6	CI-FO-	FSX: Output CLKX: Input	AXR(Outputs)/CLKX/FSX	MCASP5_VIRTUAL1_SYNC_RX	See <a href="#">Figure 5-65</a>
			AXR(Inputs)/CLKX/FSX	MCASP5_VIRTUAL1_SYNC_RX	
7	CI-FI-	CLKX / FSX: Input	AXR(Outputs)/CLKX/FSX	MCASP5_VIRTUAL1_SYNC_RX	See <a href="#">Figure 5-66</a>
			AXR(Inputs)/CLKX/FSX	MCASP5_VIRTUAL1_SYNC_RX	
8	CO-FI-	CLKX: Output FSX: Input	AXR(Outputs)/CLKX/FSX	Default (No Virtual Mode)	See <a href="#">Figure 5-67</a>
			AXR(Inputs)/CLKX/FSX	Default (No Virtual Mode)	

**Table 5-91. Virtual Mode Case Details for McASP6**

No.	CASE	CASE Description	Virtual Mode Settings		Notes
			Signals	Virtual Mode Value	
<b>IP Mode : ASYNC</b>					
1	COIFOI	CLKX / FSX: Output CLKR / FSR: Input	AXR(Outputs)/CLKX/FSX	Default (No Virtual Mode)	See <a href="#">Figure 5-60</a>
			AXR(Inputs)/CLKR/FSR	MCASP6_VIRTUAL1_SYNC_RX	
2	COIFIO	CLKX / FSR: Output CLKR / FSX: Input	AXR(Outputs)/CLKX/FSX	Default (No Virtual Mode)	See <a href="#">Figure 5-61</a>
			AXR(Inputs)/CLKR/FSR	MCASP6_VIRTUAL1_SYNC_RX	
3	CIOFIO	CLKR / FSR: Output CLKX / FSX: Input	AXR(Outputs)/CLKX/FSX	MCASP6_VIRTUAL1_SYNC_RX	See <a href="#">Figure 5-62</a>
			AXR(Inputs)/CLKR/FSR	MCASP6_VIRTUAL1_SYNC_RX	
4	CIOFOI	CLKR / FSX: Output CLKX / FSR: Input	AXR(Outputs)/CLKX/FSX	MCASP6_VIRTUAL1_SYNC_RX	See <a href="#">Figure 5-63</a>
			AXR(Inputs)/CLKR/FSR	MCASP6_VIRTUAL1_SYNC_RX	
<b>IP Mode : SYNC (CLKR / FSR internally generated from CLKX / FSX)</b>					
5	CO-FO-	CLKX / FSX: Output	AXR(Outputs)/CLKX/FSX	Default (No Virtual Mode)	See <a href="#">Figure 5-64</a>
			AXR(Inputs)/CLKX/FSX	Default (No Virtual Mode)	
6	CI-FO-	FSX: Output CLKX: Input	AXR(Outputs)/CLKX/FSX	MCASP6_VIRTUAL1_SYNC_RX	See <a href="#">Figure 5-65</a>
			AXR(Inputs)/CLKX/FSX	MCASP6_VIRTUAL1_SYNC_RX	
7	CI-FI-	CLKX / FSX: Input	AXR(Outputs)/CLKX/FSX	MCASP6_VIRTUAL1_SYNC_RX	See <a href="#">Figure 5-66</a>
			AXR(Inputs)/CLKX/FSX	MCASP6_VIRTUAL1_SYNC_RX	
8	CO-FI-	CLKX: Output FSX: Input	AXR(Outputs)/CLKX/FSX	Default (No Virtual Mode)	See <a href="#">Figure 5-67</a>
			AXR(Inputs)/CLKX/FSX	Default (No Virtual Mode)	



**Table 5-92. Virtual Mode Case Details for McASP7**

No.	CASE	CASE Description	Virtual Mode Settings		Notes
			Signals	Virtual Mode Value	
<b>IP Mode : ASYNC</b>					
1	COIFOI	CLKX / FSX: Output CLKR / FSR: Input	AXR(Outputs)/CLKX/FSX	Default (No Virtual Mode)	See <a href="#">Figure 5-60</a>
			AXR(Inputs)/CLKR/FSR	MCASP7_VIRTUAL2_SYNC_RX	
2	COIFIO	CLKX / FSR: Output CLKR / FSX: Input	AXR(Outputs)/CLKX/FSX	Default (No Virtual Mode)	See <a href="#">Figure 5-61</a>
			AXR(Inputs)/CLKR/FSR	MCASP7_VIRTUAL2_SYNC_RX	
3	CIOFIO	CLKR / FSR: Output CLKX / FSX: Input	AXR(Outputs)/CLKX/FSX	MCASP7_VIRTUAL2_SYNC_RX	See <a href="#">Figure 5-62</a>
			AXR(Inputs)/CLKR/FSR	MCASP7_VIRTUAL2_SYNC_RX	
4	CIOFOI	CLKR / FSX: Output CLKX / FSR: Input	AXR(Outputs)/CLKX/FSX	MCASP7_VIRTUAL2_SYNC_RX	See <a href="#">Figure 5-63</a>
			AXR(Inputs)/CLKR/FSR	MCASP7_VIRTUAL2_SYNC_RX	
<b>IP Mode : SYNC (CLKR / FSR internally generated from CLKX / FSX)</b>					
5	CO-FO-	CLKX / FSX: Output	AXR(Outputs)/CLKX/FSX	Default (No Virtual Mode)	See <a href="#">Figure 5-64</a>
			AXR(Inputs)/CLKX/FSX	Default (No Virtual Mode)	
6	CI-FO-	FSX: Output CLKX: Input	AXR(Outputs)/CLKX/FSX	MCASP7_VIRTUAL2_SYNC_RX	See <a href="#">Figure 5-65</a>
			AXR(Inputs)/CLKX/FSX	MCASP7_VIRTUAL2_SYNC_RX	
7	CI-FI-	CLKX / FSX: Input	AXR(Outputs)/CLKX/FSX	MCASP7_VIRTUAL2_SYNC_RX	See <a href="#">Figure 5-66</a>
			AXR(Inputs)/CLKX/FSX	MCASP7_VIRTUAL2_SYNC_RX	
8	CO-FI-	CLKX: Output FSX: Input	AXR(Outputs)/CLKX/FSX	Default (No Virtual Mode)	See <a href="#">Figure 5-67</a>
			AXR(Inputs)/CLKX/FSX	Default (No Virtual Mode)	

**Table 5-93. Virtual Mode Case Details for McASP8**

No.	CASE	CASE Description	Virtual Mode Settings		Notes
			Signals	Virtual Mode Value	
<b>IP Mode : ASYNC</b>					
1	COIFOI	CLKX / FSX: Output CLKR / FSR: Input	AXR(Outputs)/CLKX/FSX	Default (No Virtual Mode)	See <a href="#">Figure 5-60</a>
			AXR(Inputs)/CLKR/FSR	MCASP8_VIRTUAL1_SYNC_RX	
2	COIFIO	CLKX / FSR: Output CLKR / FSX: Input	AXR(Outputs)/CLKX/FSX	Default (No Virtual Mode)	See <a href="#">Figure 5-61</a>
			AXR(Inputs)/CLKR/FSR	MCASP8_VIRTUAL1_SYNC_RX	
3	CIOFIO	CLKR / FSR: Output CLKX / FSX: Input	AXR(Outputs)/CLKX/FSX	MCASP8_VIRTUAL1_SYNC_RX	See <a href="#">Figure 5-62</a>
			AXR(Inputs)/CLKR/FSR	MCASP8_VIRTUAL1_SYNC_RX	
4	CIOFOI	CLKR / FSX: Output CLKX / FSR: Input	AXR(Outputs)/CLKX/FSX	MCASP8_VIRTUAL1_SYNC_RX	See <a href="#">Figure 5-63</a>
			AXR(Inputs)/CLKR/FSR	MCASP8_VIRTUAL1_SYNC_RX	
<b>IP Mode : SYNC (CLKR / FSR internally generated from CLKX / FSX)</b>					
5	CO-FO-	CLKX / FSX: Output	AXR(Outputs)/CLKX/FSX	Default (No Virtual Mode)	See <a href="#">Figure 5-64</a>
			AXR(Inputs)/CLKX/FSX	Default (No Virtual Mode)	
6	CI-FO-	FSX: Output CLKX: Input	AXR(Outputs)/CLKX/FSX	MCASP8_VIRTUAL1_SYNC_RX	See <a href="#">Figure 5-65</a>
			AXR(Inputs)/CLKX/FSX	MCASP8_VIRTUAL1_SYNC_RX	
7	CI-FI-	CLKX / FSX: Input	AXR(Outputs)/CLKX/FSX	MCASP8_VIRTUAL1_SYNC_RX	See <a href="#">Figure 5-66</a>
			AXR(Inputs)/CLKX/FSX	MCASP8_VIRTUAL1_SYNC_RX	
8	CO-FI-	CLKX: Output FSX: Input	AXR(Outputs)/CLKX/FSX	Default (No Virtual Mode)	See <a href="#">Figure 5-67</a>
			AXR(Inputs)/CLKX/FSX	Default (No Virtual Mode)	

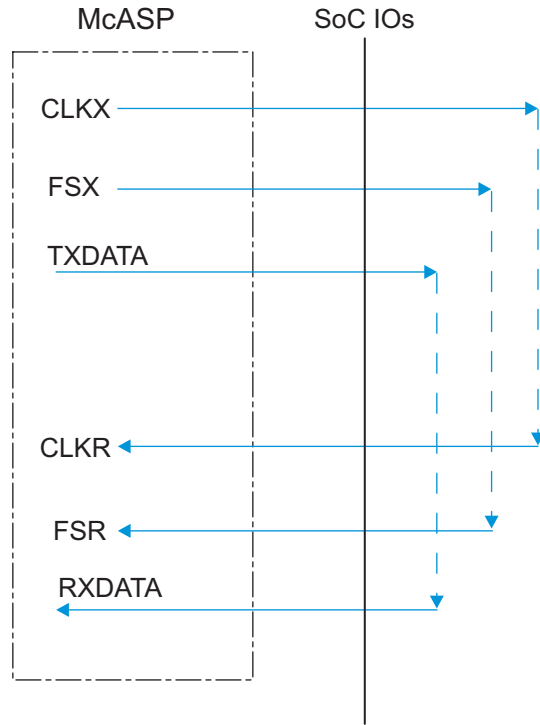

Figure 5-60. McASP1-8 COIFOI – ASYNC Mode

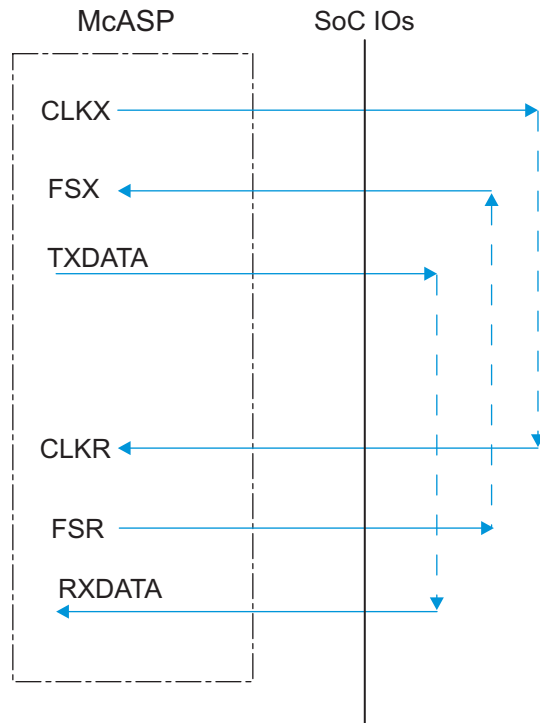

Figure 5-61. McASP1-8 COIFIO – ASYNC Mode

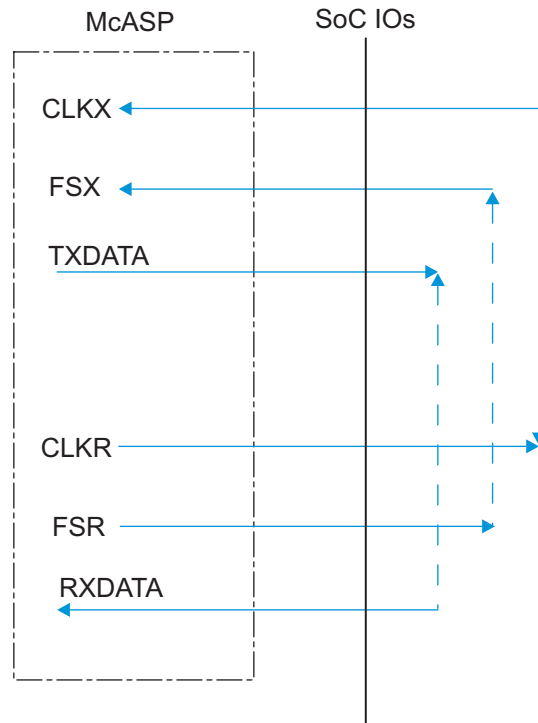

Figure 5-62. McASP1-8 CIOFIO – ASYNC Mode

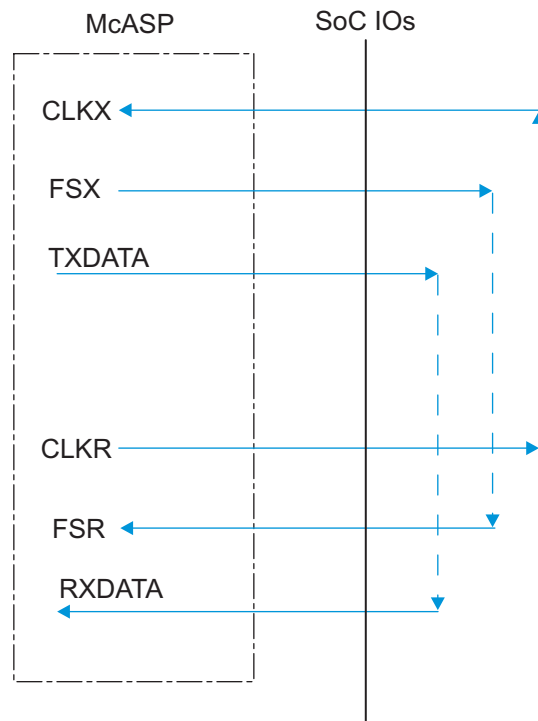

Figure 5-63. McASP1-8 CIOFOI – ASYNC Mode

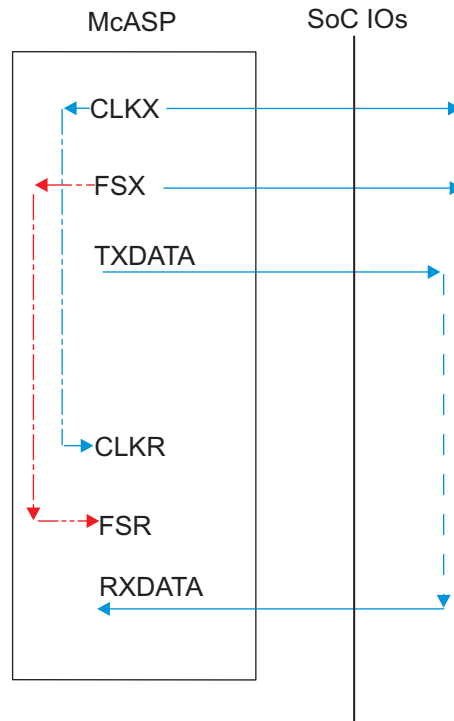

Figure 5-64. McASP1-8 CO-FO- – SYNC Mode

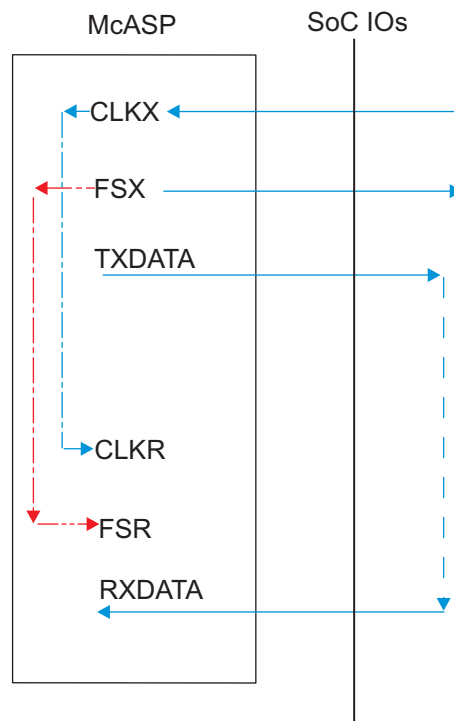

Figure 5-65. McASP1-8 CI-FO- – SYNC Mode

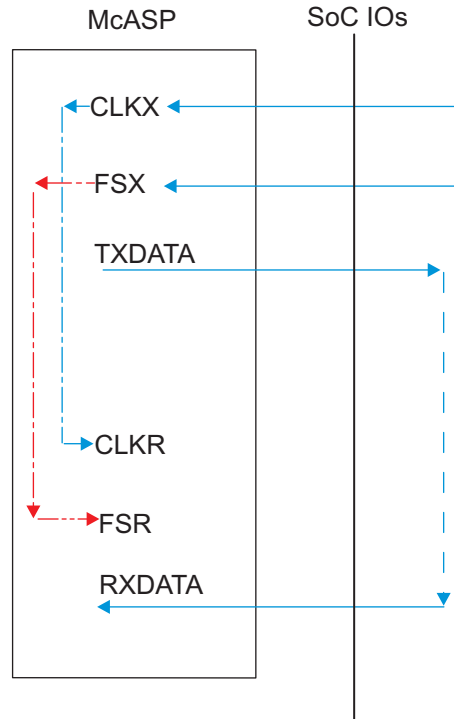

Figure 5-66. McASP1-8 CI-FI – SYNC Mode

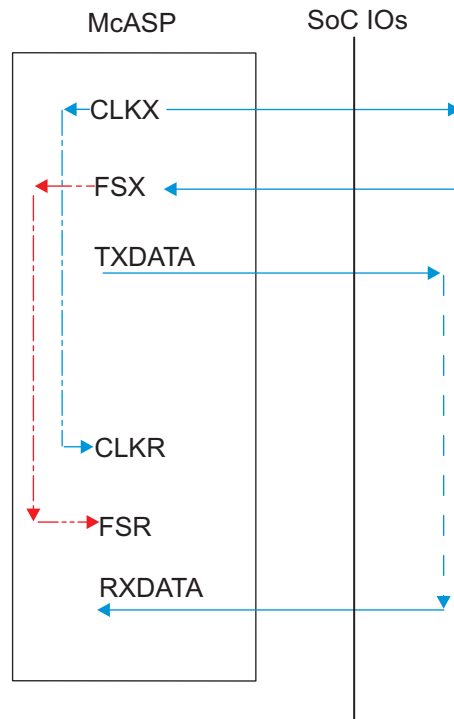

Figure 5-67. McASP1-8 CO-FI – SYNC Mode

Virtual IO Timings Modes must be used to ensure some IO timings for McASP1. See [Table 5-33, Modes Summary](#) for a list of IO timings requiring the use of Virtual IO Timings Modes. See [Table 5-94, Virtual Functions Mapping for McASP1](#) for a definition of the Virtual modes.

[Table 5-94](#) presents the values for DELAYMODE bit field.

Table 5-94. Virtual Functions Mapping for McASP1<sup>(1)</sup>

BALL	BALL NAME	Delay Mode Value			MUXMODE[15:0]		
		MCASP1_VIRTUAL1_ASYNC_TX	MCASP1_VIRTUAL2_SYNC_RX	MCASP1_VIRTUAL3_ASYNC_RX	0	1	2
E21	gpio6_14	11	15	14		mcasp1_axr8	
F20	gpio6_15	11	15	14		mcasp1_axr9	
F21	gpio6_16	11	15	14		mcasp1_axr10	
D18	xref_clk0	0	15	14			mcasp1_axr4
E17	xref_clk1	0	15	14			mcasp1_axr5
B26	xref_clk2	5	15	14			mcasp1_axr6
C23	xref_clk3	5	15	14			mcasp1_axr7
C14	mcasp1_aclkx	8	15	14	mcasp1_aclkx		
D14	mcasp1_fsx	12	15	14	mcasp1_fsx		
B14	mcasp1_aclkr	11	N/A	15	mcasp1_aclkr		
J14	mcasp1_fsr	11	N/A	15	mcasp1_fsr		
G12	mcasp1_axr0	8	15	14	mcasp1_axr0		
F12	mcasp1_axr1	8	15	14	mcasp1_axr1		
G13	mcasp1_axr2	10	15	14	mcasp1_axr2		
J11	mcasp1_axr3	10	15	14	mcasp1_axr3		
E12	mcasp1_axr4	10	15	14	mcasp1_axr4		
F13	mcasp1_axr5	10	15	14	mcasp1_axr5		
C12	mcasp1_axr6	10	15	14	mcasp1_axr6		
D12	mcasp1_axr7	10	15	14	mcasp1_axr7		
B12	mcasp1_axr8	6	15	14	mcasp1_axr8		
A11	mcasp1_axr9	6	15	14	mcasp1_axr9		
B13	mcasp1_axr10	6	15	14	mcasp1_axr10		
A12	mcasp1_axr11	6	15	14	mcasp1_axr11		
E14	mcasp1_axr12	6	15	14	mcasp1_axr12		
A13	mcasp1_axr13	6	15	14	mcasp1_axr13		
G14	mcasp1_axr14	6	15	14	mcasp1_axr14		
F14	mcasp1_axr15	6	15	14	mcasp1_axr15		

(1) NA stands for Not Applicable

Virtual IO Timings Modes must be used to ensure some IO timings for McASP2. See [Table 5-33, Modes Summary](#) for a list of IO timings requiring the use of Virtual IO Timings Modes. See [Table 5-95, Virtual Functions Mapping for McASP2](#) for a definition of the Virtual modes.

[Table 5-95](#) presents the values for DELAYMODE bit field.

**Table 5-95. Virtual Functions Mapping for McASP2<sup>(1)</sup>**

BALL	BALL NAME	Delay Mode Value					MUXMODE[15:0]		
		MCASP2_VIRTUAL1_ASYNC_RX_80M	MCASP2_VIRTUAL2_ASYNC_RX	MCASP2_VIRTUAL3_ASYNC_TX	MCASP2_VIRTUAL4_SYNC_RX	MCASP2_VIRTUAL5_SYNC_RX_80M	0	1	2
D18	xref_clk0	10	9	4	8	6		mcasp2_axr8	
E17	xref_clk1	10	9	4	8	6		mcasp2_axr9	
B26	xref_clk2	13	12	0	11	10		mcasp2_axr10	
C23	xref_clk3	13	12	0	11	10		mcasp2_axr11	
A19	mcasp2_aclkx	15	14	5	10	9	mcasp2_aclkx		
A18	mcasp2_fsx	15	14	5	10	9	mcasp2_fsx		
E15	mcasp2_aclkr	15	14	10	N/A	N/A	mcasp2_aclkr		
A20	mcasp2_fsr	15	14	10	N/A	N/A	mcasp2_fsr		
B15	mcasp2_axr0	15	14	9	13	12	mcasp2_axr0		
A15	mcasp2_axr1	15	14	9	13	12	mcasp2_axr1		
C15	mcasp2_axr2	15	14	4	10	9	mcasp2_axr2		
A16	mcasp2_axr3	15	14	4	10	9	mcasp2_axr3		
D15	mcasp2_axr4	15	14	7	13	12	mcasp2_axr4		
B16	mcasp2_axr5	15	14	7	13	12	mcasp2_axr5		
B17	mcasp2_axr6	15	14	7	13	12	mcasp2_axr6		
A17	mcasp2_axr7	15	14	7	13	12	mcasp2_axr7		
B18	mcasp3_aclkx	15	14	5	10	9			mcasp2_axr12
F15	mcasp3_fsx	15	14	4	10	9			mcasp2_axr13
B19	mcasp3_axr0	15	14	4	10	9			mcasp2_axr14
C17	mcasp3_axr1	15	14	3	10	8			mcasp2_axr15

(1) NA stands for Not Applicable.

Virtual IO Timings Modes must be used to ensure some IO timings for McASP3/4/5/6/7/8. See [Table 5-33, Modes Summary](#) for a list of IO timings requiring the use of Virtual IO Timings Modes. See [Table 5-96, Virtual Functions Mapping for McASP3/4/5/6/7/8](#) for a definition of the Virtual modes.

[Table 5-96](#) presents the values for DELAYMODE bit field.

**Table 5-96. Virtual Functions Mapping for McASP3/4/5/6/7/8**

BALL	BALL NAME	Delay Mode Value	MUXMODE[15:0]		
			0	1	2
		MCASP3_VIRTUAL2_SYNC_RX			

**Table 5-96. Virtual Functions Mapping for McASP3/4/5/6/7/8 (continued)**

BALL	BALL NAME	Delay Mode Value	MUXMODE[15:0]		
			0	1	2
C15	mcasp2_axr2	8		mcasp3_axr2	
A16	mcasp2_axr3	8		mcasp3_axr3	
B18	mcasp3_aclkx	8	mcasp3_aclkx	mcasp3_aclkr	
F15	mcasp3_fsx	8	mcasp3_fsx	mcasp3_fsr	
B19	mcasp3_axr0	8	mcasp3_axr0		
C17	mcasp3_axr1	6	mcasp3_axr1		
<b>MCASP4_VIRTUAL1_SYNC_RX</b>					
E12	mcasp1_axr4	13		mcasp4_axr2	
F13	mcasp1_axr5	13		mcasp4_axr3	
C18	mcasp4_aclkx	15	mcasp4_aclkx	mcasp4_aclkr	
A21	mcasp4_fsx	15	mcasp4_fsx	mcasp4_fsr	
G16	mcasp4_axr0	15	mcasp4_axr0		
D17	mcasp4_axr1	15	mcasp4_axr1		
<b>MCASP5_VIRTUAL1_SYNC_RX</b>					
C12	mcasp1_axr6	13		mcasp5_axr2	
D12	mcasp1_axr7	13		mcasp5_axr3	
AA3	mcasp5_aclkx	15	mcasp5_aclkx	mcasp5_aclkr	
AB9	mcasp5_fsx	15	mcasp5_fsx	mcasp5_fsr	
AB3	mcasp5_axr0	15	mcasp5_axr0		
AA4	mcasp5_axr1	15	mcasp5_axr1		
<b>MCASP6_VIRTUAL1_SYNC_RX</b>					
G13	mcasp1_axr2	13		mcasp6_axr2	
J11	mcasp1_axr3	13		mcasp6_axr3	
B12	mcasp1_axr8	10		mcasp6_axr0	
A11	mcasp1_axr9	10		mcasp6_axr1	
B13	mcasp1_axr10	10		mcasp6_aclkx	mcasp6_aclkr
A12	mcasp1_axr11	10		mcasp6_fsx	mcasp6_fsr
<b>MCASP7_VIRTUAL2_SYNC_RX</b>					
B14	mcasp1_aclkr	14		mcasp7_axr2	
J14	mcasp1_fsr	14		mcasp7_axr3	
E14	mcasp1_axr12	10		mcasp7_axr0	
A13	mcasp1_axr13	10		mcasp7_axr1	



**Table 5-96. Virtual Functions Mapping for McASP3/4/5/6/7/8 (continued)**

BALL	BALL NAME	Delay Mode Value	MUXMODE[15:0]		
			0	1	2
G14	mcasp1_axr14	10		mcasp7_aclkx	mcasp7_aclkr
F14	mcasp1_axr15	10		mcasp7_fsx	mcasp7_fsr
<b>MCASP8_VIRTUAL1_SYNC_RX</b>					
E15	mcasp2_aclkr	13		mcasp8_axr2	
A20	mcasp2_fsr	13		mcasp8_axr3	
D15	mcasp2_axr4	11		mcasp8_axr0	
B16	mcasp2_axr5	11		mcasp8_axr1	
B17	mcasp2_axr6	11		mcasp8_aclkx	mcasp8_aclkr
A17	mcasp2_axr7	11		mcasp8_fsx	mcasp8_fsr

### 5.10.6.14 USB

SuperSpeed USB DRD Subsystem has two instances in the device providing the following functions:

- USB1: SuperSpeed (SS) USB 3.0 Dual-Role-Device (DRD) subsystem with integrated SS (USB3.0) PHY and HS/FS (USB2.0) PHY.
- USB2: High Speed (HS) USB 2.0 Dual-Role-Device (DRD) subsystem with integrated HS/FS PHY.

---

#### NOTE

For more information, see *SuperSpeed USB DRD* section in the device TRM.

---

#### 5.10.6.14.1 USB1 DRD PHY

The USB1 DRD interface supports the following applications:

- USB2.0 High Speed PHY port (1.8 V and 3.3 V): this asynchronous high speed interface is compliant with the USB2.0 PHY standard with an internal transceiver (USB2.0 Standard v2.0), for a maximum data rate of 480 Mbps.
- USB3.0 SuperSpeed PHY port (1.8 V): this asynchronous differential super speed interface is compliant with the USB3.0 RX/TX PHY standard (USB3.0 Standard v1.0) for a maximum data bit rate of 5 Gbps.

#### 5.10.6.14.2 USB2 PHY

The USB2 interface supports the following applications:

- USB2.0 High Speed PHY port (1.8 V and 3.3 V): this asynchronous high speed interface is compliant with the USB2.0 PHY standard with an internal transceiver (USB2.0 Standard v2.0), for a maximum data rate of 480 Mbps.

### 5.10.6.15 SATA

The SATA RX/TX PHY interface is compliant with the SATA Standard v2.6 for a maximum data rate:

- Gen2i, Gen2m, Gen2x: 3 Gbps.
- Gen1i, Gen1m, Gen1x: 1.5 Gbps.

---

#### NOTE

For more information, see *SATA Controller* section in the device TRM.

---

### 5.10.6.16 PCIe

The device supports connections to PCIe-compliant devices via the integrated PCIe master/slave bus interface. The PCIe module is comprised of a dual-mode PCIe core and a SerDes PHY. Each PCIe subsystem controller has support for PCIe Gen-II mode (5 Gbps per lane) and Gen-I mode (2.5 Gbps per lane) (Single Lane and Flexible dual lane configuration).

The device PCIe supports the following features:

- 16-bit operation @250 MHz on PIPE interface (per 16-bit lane)
- Supports 2 ports x 1 lane or 1 port x 2 lanes configuration
- Single virtual channel (VC0), single traffic class (TC0)
- Single function in end-point mode
- Automatic width and speed negotiation
- Max payload: 128 byte outbound, 256 byte inbound
- Automatic credit management
- ECRC generation and checking

- Configurable BAR filtering
- Legacy interrupt reception (RC) and generation (EP)
- MSI generation and reception
- PCI-Express Active State Power Management (ASPM) state L0s and L1 (with exceptions)
- All PCI Device Power Management D-states with the exception of D3<sub>cold</sub> / L2 state

The PCIe controller on this device conforms to the PCI-Express Base 3.0 Specification, revision 1.0 and the PCI Local Bus Specification, revision 3.0.

---

#### **NOTE**

For more information, see *PCIe Controller* section in the device TRM.

---

### **5.10.6.17 CAN**

#### **5.10.6.17.1 DCAN**

The device provides one DCAN interface for supporting distributed realtime control with a high level of security.

The DCAN interface implements the following features:

- Supports CAN protocol version 2.0 part A, B
- Bit rates up to 1 MBit/s
- 64 message objects
- Individual identifier mask for each message object
- Programmable FIFO mode for message objects
- Programmable loop-back modes for self-test operation
- Suspend mode for debug support
- Automatic bus on after Bus-Off state by a programmable 32-bit timer
- Message RAM single error correction and double error detection (SECDED) mechanism
- Direct access to Message RAM during test mode
- Support for two interrupt lines: Level 0 and Level 1, plus separate ECC interrupt line
- Local power down and wakeup support
- Automatic message RAM initialization
- Support for DMA access

#### **5.10.6.17.2 MCAN-FD**

The device supports one MCAN-FD module connecting to the CAN network through external (for the device) transceiver for connection to the physical layer. The MCAN-FD module supports up to 5 Mbit/s data rate and is compliant to ISO 11898-1:2015.

The MCAN-FD module implements the following features:

- Conforms with ISO 11898-1:2015
- Full CAN FD support (up to 64 data bytes)
- SAE J1939 support
- Up to 32 dedicated Transmit Buffers
- Configurable Transmit FIFO, up to 32 elements
- Configurable Transmit Queue, up to 32 elements
- Configurable Transmit Event FIFO, up to 32 elements
- Up to 64 dedicated Receive Buffers
- Two configurable Receive FIFOs, up to 64 elements each

- Up to 128 filter elements
- Internal Loopback mode for self-test
- Maskable interrupts, two interrupt lines
- Two clock domains (CAN clock/Host clock)
- Parity/ECC support - Message RAM single error correction and double error detection (SECEDED) mechanism
- Local power-down and wakeup support
- Timestamp Counter

**NOTE**

For more information, see *Serial Communication Interfaces / DCAN and MCAN* sections in the device TRM.

**NOTE**

The Controller Area Network Interface x (x = 1 to 2) is also referred to as CANx.

**NOTE**

Refer to the CAN Specification for calculations necessary to validate timing compliance. Jitter tolerance calculations must be performed to validate the implementation.

Table 5-97 and Table 5-98 present timing and switching characteristics for CANx Interface.

**Table 5-97. Timing Requirements for CANx Receive**

NO.	PARAMETER	DESCRIPTION	MIN	MAX	UNIT
-	f(baud)	Maximum programmable baud rate		1	Mbps
-	t <sub>d</sub> (CANnRX)	Delay time, CANnRX pin to receive shift register		12	ns

**Table 5-98. Switching Characteristics Over Recommended Operating Conditions for CANx Transmit**

NO.	PARAMETER	DESCRIPTION	MIN	MAX	UNIT
-	f(baud)	Maximum programmable baud rate		1	Mbps
-	t <sub>d</sub> (CANnTX)	Delay time, Transmit shift register to CANnTX pin <sup>(1)</sup>		12	ns

(1) These values do not include rise/fall times of the output buffer.

### 5.10.6.18 GMAC\_SW

The three-port gigabit ethernet switch subsystem (GMAC\_SW) provides ethernet packet communication and can be configured as an ethernet switch. It provides the Gigabit Media Independent Interface (G/MII) in MII mode, Reduced Gigabit Media Independent Interface (RGMII), Reduced Media Independent Interface (RMII), and the Management Data Input/Output (MDIO) for physical layer device (PHY) management.

**NOTE**

For more information, see *Gigabit Ethernet Switch (GMAC\_SW)* section in the device TRM.

**NOTE**

The Gigabit, Reduced and Media Independent Interface n (n = 0 to 1) are also referred to as MII<sub>n</sub>, RMIIn and RGMII<sub>n</sub>.

**CAUTION**

The IO timings provided in this section are only valid if signals within a single IOSET are used. The IOSETs are defined in the [Table 5-103](#), [Table 5-106](#), [Table 5-111](#), and [Table 5-118](#).

**CAUTION**

The IO Timings provided in this section are only valid for some GMAC usage modes when the corresponding Virtual IO Timings or Manual IO Timings are configured as described in the tables found in this section.

[Table 5-99](#) and [Figure 5-68](#) present timing requirements for MII in receive operation.

**5.10.6.18.1 GMAC MII Timings**

**Table 5-99. Timing Requirements for miin\_rxclk - MII Operation**

NO.	PARAMETER	DESCRIPTION	SPEED	MIN	MAX	UNIT
MII1	$t_{c(RX\_CLK)}$	Cycle time, miin_rxclk	10 Mbps	400		ns
			100 Mbps	40		ns
MII2	$t_{w(RX\_CLKH)}$	Pulse duration, miin_rxclk high	10 Mbps	140	260	ns
			100 Mbps	14	26	ns
MII3	$t_{w(RX\_CLKL)}$	Pulse duration, miin_rxclk low	10 Mbps	140	260	ns
			100 Mbps	14	26	ns
MII4	$t_t(RX\_CLK)$	Transition time, miin_rxclk	10 Mbps		3	ns
			100 Mbps		3	ns

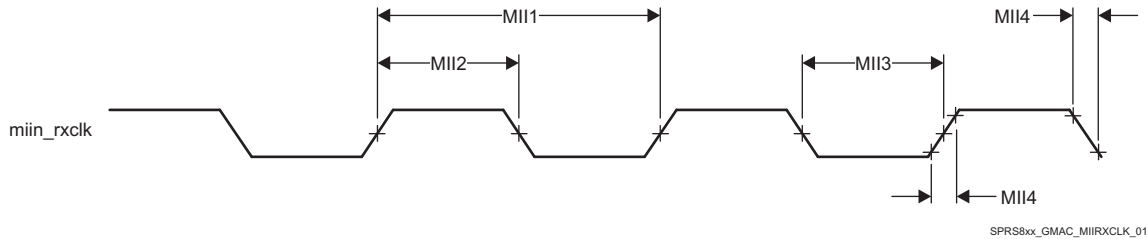

**Figure 5-68. Clock Timing (GMAC Receive) - MII in operation**

[Table 5-100](#) and [Figure 5-69](#) present timing requirements for MII in transmit operation.

**Table 5-100. Timing Requirements for miin\_txclk - MII Operation**

NO.	PARAMETER	DESCRIPTION	SPEED	MIN	MAX	UNIT
MII1	$t_{c(TX\_CLK)}$	Cycle time, miin_txclk	10 Mbps	400		ns
			100 Mbps	40		ns
MII2	$t_{w(TX\_CLKH)}$	Pulse duration, miin_txclk high	10 Mbps	140	260	ns
			100 Mbps	14	26	ns
MII3	$t_{w(TX\_CLKL)}$	Pulse duration, miin_txclk low	10 Mbps	140	260	ns
			100 Mbps	14	26	ns
MII4	$t_t(TX\_CLK)$	Transition time, miin_txclk	10 Mbps		3	ns
			100 Mbps		3	ns

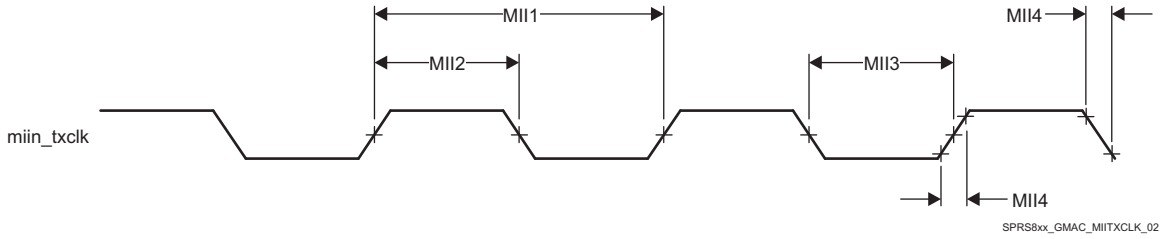

Figure 5-69. Clock Timing (GMAC Transmit) - MII<sub>n</sub> operation

Table 5-101 and Figure 5-70 present timing requirements for GMAC MII<sub>n</sub> Receive 10/100Mbit/s.

Table 5-101. Timing Requirements for GMAC MII<sub>n</sub> Receive 10/100 Mbit/s

NO.	PARAMETER	DESCRIPTION	MIN	MAX	UNIT
MII1	$t_{su}(RXD-RX\_CLK)$	Setup time, receive selected signals valid before miin_rxclk	8		ns
	$t_{su}(RX\_DV-RX\_CLK)$				
	$t_{su}(RX\_ER-RX\_CLK)$				
MII2	$t_h(RX\_CLK-RXD)$	Hold time, receive selected signals valid after miin_rxclk	8		ns
	$t_h(RX\_CLK-RX\_DV)$				
	$t_h(RX\_CLK-RX\_ER)$				

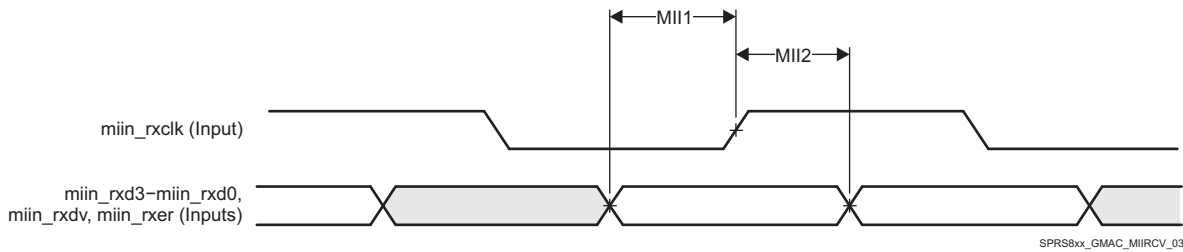

Figure 5-70. GMAC Receive Interface Timing MII<sub>n</sub> operation

Table 5-102 and Figure 5-71 present timing requirements for GMAC MII<sub>n</sub> transmit 10/100 Mbit/s.

Table 5-102. Switching Characteristics Over Recommended Operating Conditions for GMAC MII<sub>n</sub> Transmit 10/100 Mbits/s

NO.	PARAMETER	DESCRIPTION	MIN	MAX	UNIT
MII1	$t_d(TX\_CLK-TXD)$	Delay time, miin_txclk to transmit selected signals valid	0	25	ns
	$t_d(TX\_CLK-TX\_EN)$				
	$t_d(TX\_CLK-TX\_ER)$				

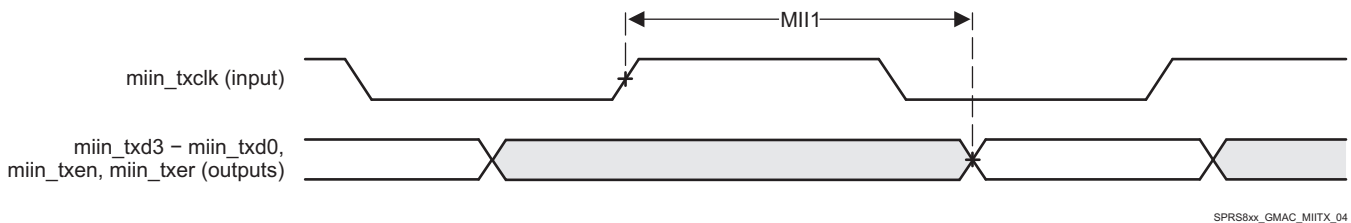

Figure 5-71. GMAC Transmit Interface Timing MII<sub>n</sub> operation

In Table 5-103 are presented the specific groupings of signals (IOSET) for use with GMAC MII signals.

**Table 5-103. GMAC MII IOSETs**

SIGNALS	IOSET5		IOSET6	
	BALL	MUX	BALL	MUX
<b>GMAC MII1</b>				
mii1_txd3	C5	8		
mii1_txd2	D6	8		
mii1_txd1	B2	8		
mii1_txd0	C4	8		
mii1_rxd3	F5	8		
mii1_rxd2	E4	8		
mii1_rxd1	C1	8		
mii1_rxd0	E6	8		
mii1_col	B4	8		
mii1_rxer	B3	8		
mii1_txer	A3	8		
mii1_txen	A4	8		
mii1_crs	B5	8		
mii1_rxclk	D5	8		
mii1_txclk	C3	8		
mii1_rxdv	C2	8		
<b>GMAC MII0</b>				
mii0_txd3			V5	3
mii0_txd2			V4	3
mii0_txd1			Y2	3
mii0_txd0			W2	3
mii0_rxd3			W9	3
mii0_rxd2			V9	3
mii0_rxd1			V6	3
mii0_rxd0			U6	3
mii0_txclk			U5	3
mii0_txer			U4	3
mii0_rxer			U7	3
mii0_rxdv			V2	3
mii0_crs			V7	3
mii0_col			V1	3
mii0_rxclk			Y1	3
mii0_txen			V3	3

### 5.10.6.18.2 GMAC MDIO Interface Timings

#### CAUTION

The IO timings provided in this section are only valid for some GMAC usage modes when the corresponding Virtual IO Timings or Manual IO Timings are configured as described in the tables found in this section.

Table 5-104, Table 5-104, and Figure 5-72 present timing requirements for MDIO.

**Table 5-104. Timing Requirements for MDIO Input**

No	PARAMETER	DESCRIPTION	MIN	MAX	UNIT
MDIO1	$t_{c(MDC)}$	Cycle time, MDC	400		ns
MDIO2	$t_{w(MDCH)}$	Pulse Duration, MDC High	160		ns
MDIO3	$t_{w(MDCL)}$	Pulse Duration, MDC Low	160		ns
MDIO4	$t_{su(MDIO-MDC)}$	Setup time, MDIO valid before MDC High	90		ns
MDIO5	$t_{h(MDIO\_MDC)}$	Hold time, MDIO valid from MDC High	0		ns

**Table 5-105. Switching Characteristics Over Recommended Operating Conditions for MDIO Output**

NO	PARAMETER	DESCRIPTION	MIN	MAX	UNIT
MDIO6	$t_{t(MDC)}$	Transition time, MDC		5	ns
MDIO7	$t_{d(MDC-MDIO)}$	Delay time, MDC low to MDIO valid	-150	150	ns

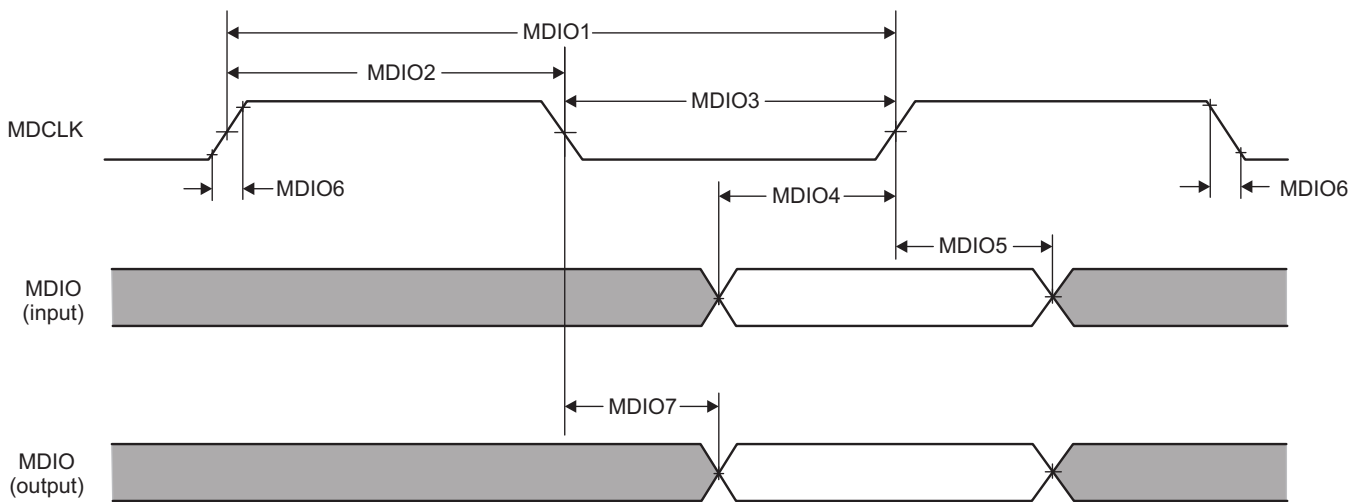

**Figure 5-72. GMAC MDIO Diagrams**

In [Table 5-106](#) are presented the specific groupings of signals (IOSET) for use with GMAC MDIO signals.

**Table 5-106. GMAC MDIO IOSETs**

SIGNALS	IOSET7		IOSET8		IOSET9		IOSET10	
	BALL	MUX	BALL	MUX	BALL	MUX	BALL	MUX
mdio_d	F6	3	U4	0	AB4	1	B20	5
mdio_mclk	D3	3	V1	0	AC5	1	B21	5

**5.10.6.18.3 GMAC RMII Timings**

The main reference clock REF\_CLK (RMII\_50MHZ\_CLK) of RMII interface is internally supplied from PRCM. The source of this clock could be either externally sourced from the RMII\_MHZ\_50\_CLK pin of the device or internally generated from DPLL\_GMAC output clock GMAC\_RMII\_HS\_CLK. See the PRCM chapter of the Device TRM for full details about RMII reference clock.

**CAUTION**

The IO Timings provided in this section are only valid for some GMAC usage modes when the corresponding Virtual IO Timings or Manual IO Timings are configured as described in the tables found in this section.



Table 5-107, Table 5-108 and Figure 5-73 present timing requirements for GMAC RMIIn receive.

**Table 5-107. Timing Requirements for GMAC REF\_CLK - RMIIn Operation**

NO.	PARAMETER	DESCRIPTION	MIN	MAX	UNIT
RMII1	$t_{c(REF\_CLK)}$	Cycle time, REF_CLK	20		ns
RMII2	$t_{w(REF\_CLKH)}$	Pulse duration, REF_CLK high	7	13	ns
RMII3	$t_{w(REF\_CLKL)}$	Pulse duration, REF_CLK low	7	13	ns
RMII4	$t_{t(REF\_CLK)}$	Transistion time, REF_CLK		3	ns

**Table 5-108. Timing Requirements for GMAC RMIIn Receive**

NO.	PARAMETER	DESCRIPTION	MIN	MAX	UNIT
RMII5	$t_{su}(RXD-REF\_CLK)$	Setup time, receive selected signals valid before REF_CLK	4		ns
	$t_{su}(CRS\_DV-REF\_CLK)$				
	$t_{su}(RX\_ER-REF\_CLK)$				
RMII6	$t_h(REF\_CLK-RXD)$	Hold time, receive selected signals valid after REF_CLK	2		ns
	$t_h(REF\_CLK-CRS\_DV)$				
	$t_h(REF\_CLK-RX\_ER)$				

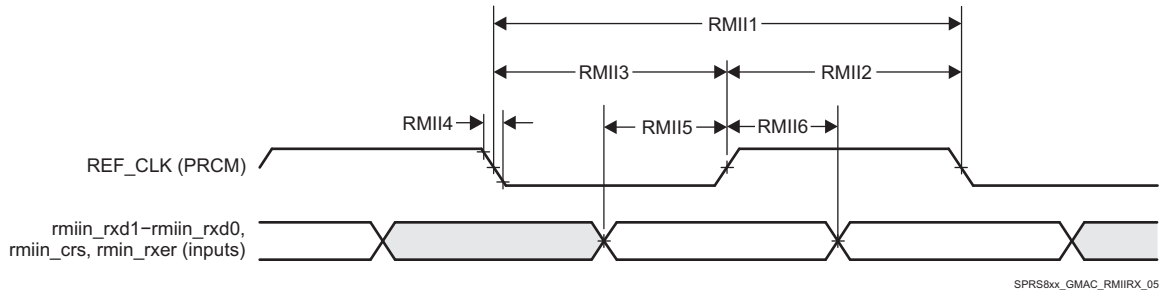

**Figure 5-73. GMAC Receive Interface Timing RMIIn Operation**

Table 5-109, Table 5-109 and Figure 5-74 present switching characteristics for GMAC RMIIn transmit 10/100 Mbit/s.

**Table 5-109. Switching Characteristics Over Recommended Operating Conditions for GMAC REF\_CLK - RMIIn Operation**

NO.	PARAMETER	DESCRIPTION	MIN	MAX	UNIT
RMII7	$t_{c(REF\_CLK)}$	Cycle time, REF_CLK	20		ns
RMII8	$t_{w(REF\_CLKH)}$	Pulse duration, REF_CLK high	7	13	ns
RMII9	$t_{w(REF\_CLKL)}$	Pulse duration, REF_CLK low	7	13	ns
RMII10	$t_{t(REF\_CLK)}$	Transistion time, REF_CLK		3	ns

**Table 5-110. Switching Characteristics Over Recommended Operating Conditions for GMAC RMIIn Transmit 10/100 Mb/s**

NO.	PARAMETER	DESCRIPTION	RMIIn	MIN	MAX	UNIT
RMII11	$t_{d(REF\_CLK-TXD)}$	Delay time, REF_CLK high to selected transmit signals valid	RMII0	2	13.5	ns
	$t_{dd(REF\_CLK-TXEN)}$					
	$t_{d(REF\_CLK-TXD)}$		RMII1	2	13.8	ns
	$t_{dd(REF\_CLK-TXEN)}$					

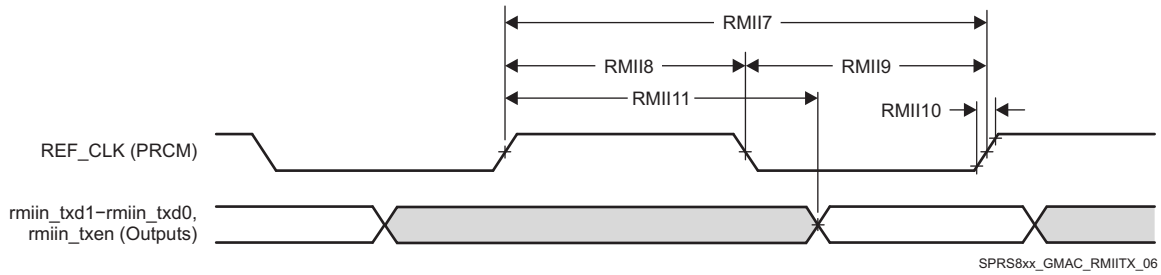

Figure 5-74. GMAC Transmit Interface Timing RMIIn Operation

In Table 5-111 are presented the specific groupings of signals (IOSET) for use with GMAC RMII signals.

Table 5-111. GMAC RMII IOSETs

SIGNALS	IOSET1		IOSET2	
	BALL	MUX	BALL	MUX
<b>GMAC RMII1</b>				
RMII_MHZ_50_CLK	U3	0		
rmi1_txd1	V5	2		
rmi1_txd0	V4	2		
rmi1_rxd1	W9	2		
rmi1_rxd0	V9	2		
rmi1_rxer	Y1	2		
rmi1_txen	U5	2		
rmi1_crs	V2	2		
<b>GMAC RMII0</b>				
RMII_MHZ_50_CLK			U3	0
rmi0_txd1			Y2	1
rmi0_txd0			W2	1
rmi0_rxd1			V6	1
rmi0_rxd0			U6	1
rmi0_txen			V3	1
rmi0_rxer			U7	1
rmi0_crs			V7	1

Manual IO Timings Modes must be used to ensure some IO timings for GMAC. See Table 5-33, Modes Summary for a list of IO timings requiring the use of Manual IO Timings Modes. See Table 5-112, Manual Functions Mapping for GMAC RMII0 for a definition of the Manual modes.

Table 5-112 lists the A\_DELAY and G\_DELAY values needed to calculate the correct values to be set in the CFG\_x registers.

Table 5-112. Manual Functions Mapping for GMAC RMII0

BALL	BALL NAME	GMAC_RMII0_MANUAL1		CFG REGISTER	MUXMODE	
		A_DELAY (ps)	G_DELAY (ps)		0	1
U3	RMII_MHZ_50_CLK	0	0	CFG_RMII_MHZ_50_CLK_IN	RMII_MHZ_50_CLK	
U6	rgmii0_txd0	500	500	CFG_RGMII0_TXD0_IN		rmi0_rxd0
V6	rgmii0_txd1	840	1000	CFG_RGMII0_TXD1_IN		rmi0_rxd1
U7	rgmii0_txd2	360	840	CFG_RGMII0_TXD2_IN		rmi0_rxer
V7	rgmii0_txd3	600	1000	CFG_RGMII0_TXD3_IN		rmi0_crs

Manual IO Timings Modes must be used to ensure some IO timings for GMAC. See [Table 5-33, Modes Summary](#) for a list of IO timings requiring the use of Manual IO Timings Modes. See [Table 5-113, Manual Functions Mapping for GMAC RMII1](#) for a definition of the Manual modes.

[Table 5-113](#) list the A\_DELAY and G\_DELAY values needed to calculate the correct values to be set in the CFG\_x registers.

**Table 5-113. Manual Functions Mapping for GMAC RMII1**

BALL	BALL NAME	GMAC_RMII1_MANUAL1		CFG REGISTER	MUXMODE	
		A_DELAY (ps)	G_DELAY (ps)		0	2
U3	RMII_MHZ_50_CLK	0	0	CFG_RMII_MHZ_50_CLK_IN	RMII_MHZ_50_CLK	
W9	rgmii0_txc	300	1200	CFG_RGMII0_TXC_IN		rmii1_rxd1
V9	rgmii0_txctl	300	1000	CFG_RGMII0_TXCTL_IN		rmii1_rxd0
V2	uart3_rxd	400	700	CFG_UART3_RXD_IN		rmii1_crs
Y1	uart3_txd	300	500	CFG_UART3_TXD_IN		rmii1_rxer

**5.10.6.18.4 GMAC RGMII Timings**

**CAUTION**

The IO Timings provided in this section are only valid for some GMAC usage modes when the corresponding Virtual IO Timings or Manual IO Timings are configured as described in the tables found in this section.

[Table 5-114](#), [Table 5-115](#), and [Figure 5-75](#) present timing requirements for receive RGMII operation.

**Table 5-114. Timing Requirements for rgmiin\_rxc - RGMII Operation**

NO.	PARAMETER	DESCRIPTION	SPEED	MIN	MAX	UNIT
RGMII1	t <sub>c</sub> (RXC)	Cycle time, rgmiin_rxc	10 Mbps	360	440	ns
			100 Mbps	36	44	ns
			1000 Mbps	7.2	8.8	ns
RGMII2	t <sub>w</sub> (RXCH)	Pulse duration, rgmiin_rxc high	10 Mbps	160	240	ns
			100 Mbps	16	24	ns
			1000 Mbps	3.6	4.4	ns
RGMII3	t <sub>w</sub> (RXCL)	Pulse duration, rgmiin_rxc low	10 Mbps	160	240	ns
			100 Mbps	16	24	ns
			1000 Mbps	3.6	4.4	ns
RGMII4	t <sub>t</sub> (RXC)	Transition time, rgmiin_rxc	10 Mbps		0.75	ns
			100 Mbps		0.75	ns
			1000 Mbps		0.75	ns

**Table 5-115. Timing Requirements for GMAC RGMII Input Receive for 10/100/1000 Mbps <sup>(1)</sup>**

NO.	PARAMETER	DESCRIPTION	MIN	MAX	UNIT
RGMII5	t <sub>su</sub> (RXD-RXCH)	Setup time, receive selected signals valid before rgmiin_rxc high/low	1		ns
RGMII6	t <sub>h</sub> (RXCH-RXD)	Hold time, receive selected signals valid after rgmiin_rxc high/low	1		ns

(1) For RGMII, receive selected signals include: rgmiin\_rxd[3:0] and rgmiin\_rxctl.

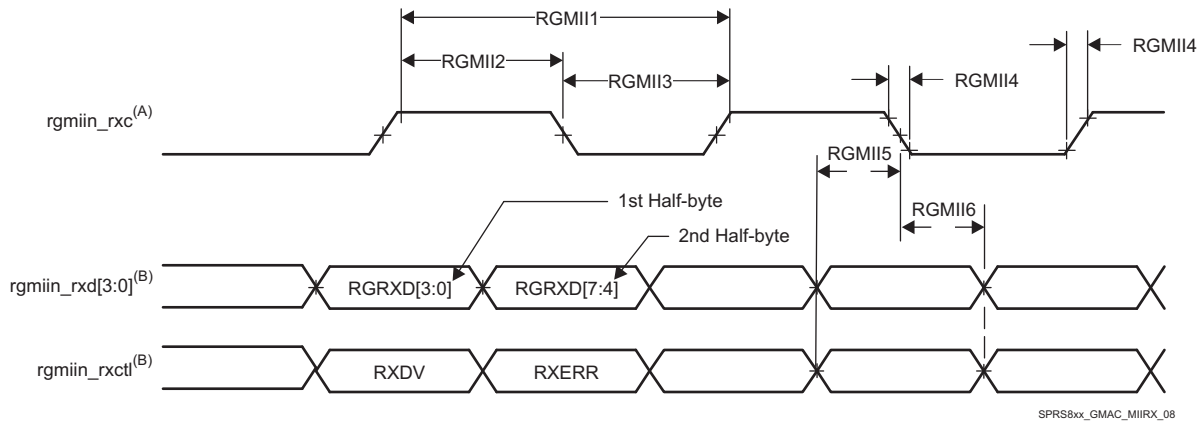

- A. rgmiin\_rxc must be externally delayed relative to the data and control pins.
- B. Data and control information is received using both edges of the clocks. rgmiin\_rxd[3:0] carries data bits 3-0 on the rising edge of rgmiin\_rxc and data bits 7-4 on the falling edge of rgmiin\_rxc. Similarly, rgmiin\_rxctl carries RXDV on rising edge of rgmiin\_rxc and RXERR on falling edge of rgmiin\_rxc.

**Figure 5-75. GMAC Receive Interface Timing, RGMII In Operation**

Table 5-116, Table 5-117, and Figure 5-76 present switching characteristics for transmit - RGMII In for 10/100/1000 Mbit/s.

**Table 5-116. Switching Characteristics Over Recommended Operating Conditions for rgmiin\_txctl - RGMII In Operation for 10/100/1000 Mbit/s**

NO.	PARAMETER	DESCRIPTION	SPEED	MIN	MAX	UNIT
RGMII1	$t_{c(TXC)}$	Cycle time, rgmiin_txc	10 Mbps	360	440	ns
			100 Mbps	36	44	ns
			1000 Mbps	7.2	8.8	ns
RGMII2	$t_{w(TXCH)}$	Pulse duration, rgmiin_txc high	10 Mbps	160	240	ns
			100 Mbps	16	24	ns
			1000 Mbps	3.6	4.4	ns
RGMII3	$t_{w(TXCL)}$	Pulse duration, rgmiin_txc low	10 Mbps	160	240	ns
			100 Mbps	16	24	ns
			1000 Mbps	3.6	4.4	ns
RGMII4	$t_{t(TXC)}$	Transition time, rgmiin_txc	10 Mbps		0.75	ns
			100 Mbps		0.75	ns
			1000 Mbps		0.75	ns

**Table 5-117. Switching Characteristics for GMAC RGMII In Output Transmit for 10/100/1000 Mbps (1)**

NO.	PARAMETER	DESCRIPTION	MODE	MIN	MAX	UNIT
RGMII5	$t_{osu(TXD-TXC)}$	Output Setup time, transmit selected signals valid to rgmiin_txc high/low	RGMII0, Internal Delay Enabled, 1000 Mbps	1.05 <sup>(2)</sup>		ns
			RGMII0, Internal Delay Enabled, 10/100 Mbps	1.2		ns
			RGMII1, Internal Delay Enabled, 1000 Mbps	1.05 <sup>(3)</sup>		ns
			RGMII1, Internal Delay Enabled, 10/100 Mbps	1.2		ns

**Table 5-117. Switching Characteristics for GMAC RGMII<sub>n</sub> Output Transmit for 10/100/1000 Mbps (1) (continued)**

NO.	PARAMETER	DESCRIPTION	MODE	MIN	MAX	UNIT
RGMII6	t <sub>oh(TXC-TXD)</sub>	Output Hold time, transmit selected signals valid after rgmiin_txc high/low	RGMII0, Internal Delay Enabled, 1000 Mbps	1.05 <sup>(2)</sup>		ns
			RGMII0, Internal Delay Enabled, 10/100 Mbps	1.2		ns
			RGMII1, Internal Delay Enabled, 1000 Mbps	1.05 <sup>(3)</sup>		ns
			RGMII1, Internal Delay Enabled, 10/100 Mbps	1.2		ns

- (1) For RGMII, transmit selected signals include: rgmiin\_txd[3:0] and rgmiin\_txctl.
- (2) RGMII0 1000 Mbps operation requires that the 4 data pins rgmii0\_txd[3:0] and rgmii0\_txctl have their board propagation delays matched within 50 pS of rgmii0\_txc.
- (3) RGMII1 1000 Mbps operation requires that the 4 data pins rgmii1\_txd[3:0] and rgmii1\_txctl have their board propagation delays matched within 50 pS of rgmii1\_txc.

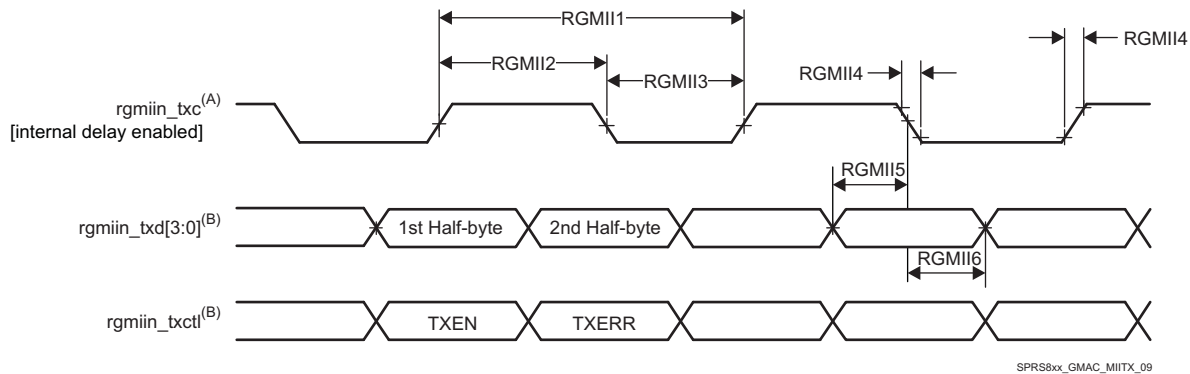

- A. TXC is delayed internally before being driven to the rgmiin\_txc pin. This internal delay is always enabled.
- B. Data and control information is transmitted using both edges of the clocks. rgmiin\_txd[3:0] carries data bits 3-0 on the rising edge of rgmiin\_txc and data bits 7-4 on the falling edge of rgmiin\_txc. Similarly, rgmiin\_txctl carries TXEN on rising edge of rgmiin\_txc and TXERR of falling edge of rgmiin\_txc.

**Figure 5-76. GMAC Transmit Interface Timing RGMII<sub>n</sub> Operation**

In [Table 5-118](#) are presented the specific groupings of signals (IOSET) for use with GMAC RGMII signals.

**Table 5-118. GMAC RGMII IOSETs**

SIGNALS	IOSET3		IOSET4	
	BALL	MUX	BALL	MUX
<b>GMAC RGMII1</b>				
rgmii1_txd3	C3	3		
rgmii1_txd2	C4	3		
rgmii1_txd1	B2	3		
rgmii1_txd0	D6	3		
rgmii1_rxd3	B3	3		
rgmii1_rxd2	B4	3		
rgmii1_rxd1	B5	3		
rgmii1_rxd0	A4	3		
rgmii1_rxctl	A3	3		
rgmii1_txc	D5	3		
rgmii1_txctl	C2	3		
rgmii1_rxc	C5	3		
<b>GMAC RGMII0</b>				

**Table 5-118. GMAC RGMII IOSETs (continued)**

SIGNALS	IOSET3		IOSET4	
	BALL	MUX	BALL	MUX
rgmii0_txd3			V7	0
rgmii0_txd2			U7	0
rgmii0_txd1			V6	0
rgmii0_txd0			U6	0
rgmii0_rxd3			V4	0
rgmii0_rxd2			V3	0
rgmii0_rxd1			Y2	0
rgmii0_rxd0			W2	0
rgmii0_txc			W9	0
rgmii0_rxctl			V5	0
rgmii0_rxc			U5	0
rgmii0_txctl			V9	0

**NOTE**

To configure the desired manual IO timing mode the user must follow the steps described in *Manual IO Timing Modes* section in the device TRM.

The associated registers to configure are listed in the **CFG REGISTER** column. For more information, see *Control Module* chapter in the device TRM.

Manual IO Timings Modes must be used to ensure some IO timings for GMAC. See [Table 5-33, Modes Summary](#) for a list of IO timings requiring the use of Manual IO Timings Modes. See [Table 5-119, Manual Functions Mapping for GMAC RGMII0](#) for a definition of the Manual modes.

[Table 5-120](#) lists the A\_DELAY and G\_DELAY values needed to calculate the correct values to be set in the CFG\_x registers.

**Table 5-119. Manual Functions Mapping for GMAC RGMII0**

BALL	BALL NAME	GMAC_RGMII0_MANUAL1		CFG REGISTER	MUXMODE
		A_DELAY (ps)	G_DELAY (ps)		0
U5	rgmii0_rxc	451	0	CFG_RGMII0_RXC_IN	rgmii0_rxc
V5	rgmii0_rxctl	127	1571	CFG_RGMII0_RXCTL_IN	rgmii0_rxctl
W2	rgmii0_rxd0	165	1178	CFG_RGMII0_RXD0_IN	rgmii0_rxd0
Y2	rgmii0_rxd1	136	1302	CFG_RGMII0_RXD1_IN	rgmii0_rxd1
V3	rgmii0_rxd2	0	1520	CFG_RGMII0_RXD2_IN	rgmii0_rxd2
V4	rgmii0_rxd3	28	1690	CFG_RGMII0_RXD3_IN	rgmii0_rxd3
W9	rgmii0_txc	121	0	CFG_RGMII0_TXC_OUT	rgmii0_txc
V9	rgmii0_txctl	410	0	CFG_RGMII0_TXCTL_OUT	rgmii0_txctl
U6	rgmii0_txd0	483	0	CFG_RGMII0_TXD0_OUT	rgmii0_txd0
V6	rgmii0_txd1	335	0	CFG_RGMII0_TXD1_OUT	rgmii0_txd1
U7	rgmii0_txd2	330	0	CFG_RGMII0_TXD2_OUT	rgmii0_txd2
V7	rgmii0_txd3	522	0	CFG_RGMII0_TXD3_OUT	rgmii0_txd3

Manual IO Timings Modes must be used to ensure some IO timings for GMAC. See [Table 5-33, Modes Summary](#) for a list of IO timings requiring the use of Manual IO Timings Modes. See [Table 5-120, Manual Functions Mapping for GMAC RGMII1](#) for a definition of the Manual modes.

[Table 5-120](#) lists the A\_DELAY and G\_DELAY values needed to calculate the correct values to be set in the CFG\_x registers.

**Table 5-120. Manual Functions Mapping for GMAC RGMII1**

BALL	BALL NAME	GMAC_RGMII1_MANUAL1		CFG REGISTER	MUXMODE
		A_DELAY (ps)	G_DELAY (ps)		3
C5	vin2a_d18	417	0	CFG_VIN2A_D18_IN	rgmii1_rxc
A3	vin2a_d19	156	843	CFG_VIN2A_D19_IN	rgmii1_rxctl
B3	vin2a_d20	223	1413	CFG_VIN2A_D20_IN	rgmii1_rxd3
B4	vin2a_d21	169	1415	CFG_VIN2A_D21_IN	rgmii1_rxd2
B5	vin2a_d22	43	1150	CFG_VIN2A_D22_IN	rgmii1_rxd1
A4	vin2a_d23	0	1210	CFG_VIN2A_D23_IN	rgmii1_rxd0
D5	vin2a_d12	147	0	CFG_VIN2A_D12_OUT	rgmii1_txc
C2	vin2a_d13	480	0	CFG_VIN2A_D13_OUT	rgmii1_txctl
C3	vin2a_d14	378	0	CFG_VIN2A_D14_OUT	rgmii1_txd3
C4	vin2a_d15	562	0	CFG_VIN2A_D15_OUT	rgmii1_txd2
B2	vin2a_d16	483	0	CFG_VIN2A_D16_OUT	rgmii1_txd1
D6	vin2a_d17	380	0	CFG_VIN2A_D17_OUT	rgmii1_txd0

### 5.10.6.19 eMMC/SD/SDIO

The Device includes the following external memory interfaces 4 MultiMedia Card/Secure Digital/Secure Digital Input Output Interface (MMC/SD/SDIO).

#### NOTE

The eMMC/SD/SDIO<sub>i</sub> (i = 1 to 4) controller is also referred to as MMC<sub>i</sub>.

#### 5.10.6.19.1 MMC1—SD Card Interface

MMC1 interface is compliant with the SD Standard v3.01 and it supports the following SD Card applications:

- Default speed, 4-bit data, SDR, half-cycle
- High speed, 4-bit data, SDR, half-cycle
- SDR12, 4-bit data, half-cycle
- SDR25, 4-bit data, half-cycle
- UHS-I SDR50, 4-bit data, half-cycle
- UHS-I SDR104, 4-bit data, half-cycle
- UHS-I DDR50, 4-bit data

#### NOTE

For more information, see eMMC/SD/SDIO chapter in the device TRM.

#### 5.10.6.19.1.1 Default speed, 4-bit data, SDR, half-cycle

Table 5-121 and Table 5-122 present timing requirements and switching characteristics for MMC1 - default speed in receiver and transmitter mode (see Figure 5-77 and Figure 5-78)

**Table 5-121. Timing Requirements for MMC1 - SD Card Default Speed Mode**

NO.	PARAMETER	DESCRIPTION	MIN	MAX	UNIT
DSSD5	$t_{su(cmdV-clkH)}$	Setup time, mmc1_cmd valid before mmc1_clk rising clock edge	5.11		ns
DSSD6	$t_h(clkH-cmdV)$	Hold time, mmc1_cmd valid after mmc1_clk rising clock edge	20.46		ns
DSSD7	$t_{su(dV-clkH)}$	Setup time, mmc1_dat[3:0] valid before mmc1_clk rising clock edge	5.11		ns

**Table 5-121. Timing Requirements for MMC1 - SD Card Default Speed Mode (continued)**

NO.	PARAMETER	DESCRIPTION	MIN	MAX	UNIT
DSSD8	$t_{h(\text{clkH-dV})}$	Hold time, mmc1_dat[3:0] valid after mmc1_clk rising clock edge	20.46		ns

**Table 5-122. Switching Characteristics for MMC1 - SD Card Default Speed Mode**

NO.	PARAMETER	DESCRIPTION	MIN	MAX	UNIT
DSSD0	fop(clk)	Operating frequency, mmc1_clk		24	MHz
DSSD1	$t_{w(\text{clkH})}$	Pulse duration, mmc1_clk high	0.5P-0.185 <sup>(1)</sup>		ns
DSSD2	$t_{w(\text{clkL})}$	Pulse duration, mmc1_clk low	0.5P-0.185 <sup>(1)</sup>		ns
DSSD3	$t_{d(\text{clkL-cmdV})}$	Delay time, mmc1_clk falling clock edge to mmc1_cmd transition	-14.93	14.93	ns
DSSD4	$t_{d(\text{clkL-dV})}$	Delay time, mmc1_clk falling clock edge to mmc1_dat[3:0] transition	-14.93	14.93	ns

(1) P = output mmc1\_clk period in ns

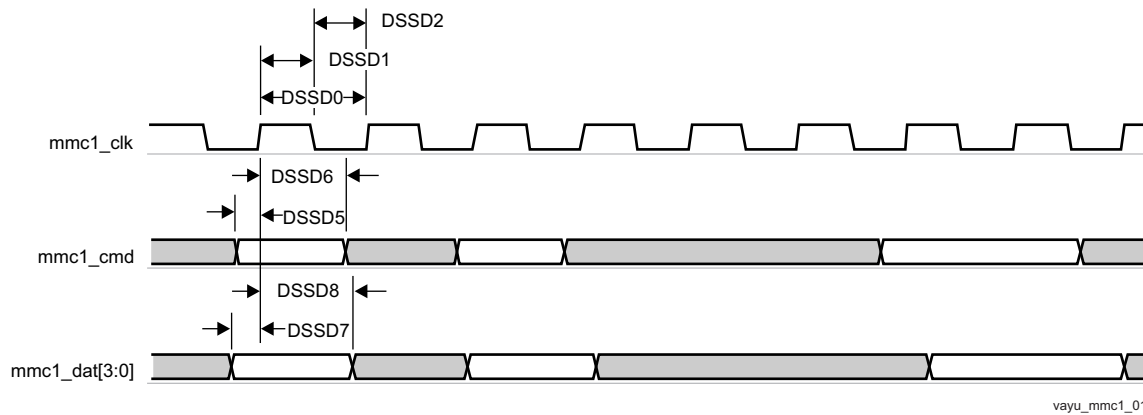

**Figure 5-77. MMC/SD/SDIO in - Default Speed - Receiver Mode**

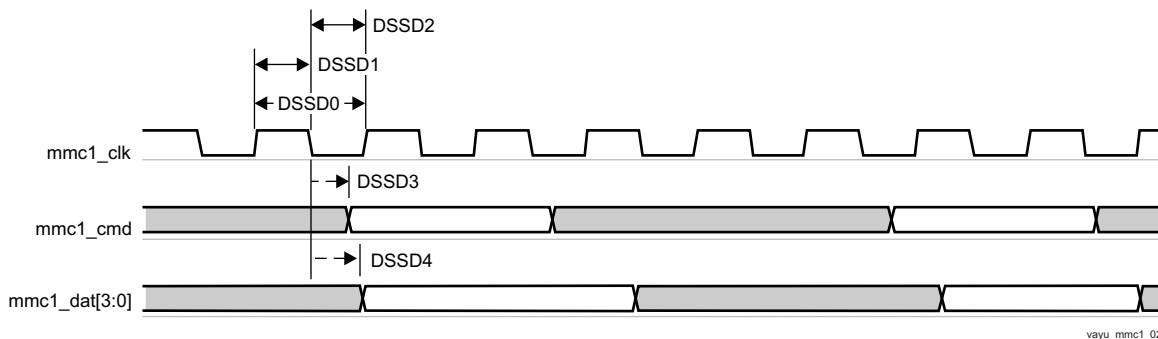

**Figure 5-78. MMC/SD/SDIO in - Default Speed - Transmitter Mode**

**5.10.6.19.1.2 High speed, 4-bit data, SDR, half-cycle**

Table 5-123 and Table 5-124 present timing requirements and switching characteristics for MMC1 - high speed in receiver and transmitter mode (see Figure 5-79 and Figure 5-80)

**Table 5-123. Timing Requirements for MMC1 - SD Card High Speed Mode**

NO.	PARAMETER	DESCRIPTION	MIN	MAX	UNIT
HSSD3	$t_{su(\text{cmdV-clkH})}$	Setup time, mmc1_cmd valid before mmc1_clk rising clock edge	5.3		ns
HSSD4	$t_{h(\text{clkH-cmdV})}$	Hold time, mmc1_cmd valid after mmc1_clk rising clock edge	2.6		ns
HSSD7	$t_{su(\text{dV-clkH})}$	Setup time, mmc1_dat[3:0] valid before mmc1_clk rising clock edge	5.3		ns



**Table 5-123. Timing Requirements for MMC1 - SD Card High Speed Mode (continued)**

NO.	PARAMETER	DESCRIPTION	MIN	MAX	UNIT
HSSD8	$t_{h(\text{clkH-dV})}$	Hold time, mmc1_dat[3:0] valid after mmc1_clk rising clock edge	2.6		ns

**Table 5-124. Switching Characteristics for MMC1 - SD Card High Speed Mode**

NO.	PARAMETER	DESCRIPTION	MIN	MAX	UNIT
HSSD1	$f_{\text{op}(\text{clk})}$	Operating frequency, mmc1_clk		48	MHz
HSSD2H	$t_{w(\text{clkH})}$	Pulse duration, mmc1_clk high	0.5P-0.185 <sup>(1)</sup>		ns
HSSD2L	$t_{w(\text{clkL})}$	Pulse duration, mmc1_clk low	0.5P-0.185 <sup>(1)</sup>		ns
HSSD5	$t_{d(\text{clkL-cmdV})}$	Delay time, mmc1_clk falling clock edge to mmc1_cmd transition	-7.6	3.6	ns
HSSD6	$t_{d(\text{clkL-dV})}$	Delay time, mmc1_clk falling clock edge to mmc1_dat[3:0] transition	-7.6	3.6	ns

(1) P = output mmc1\_clk period in ns

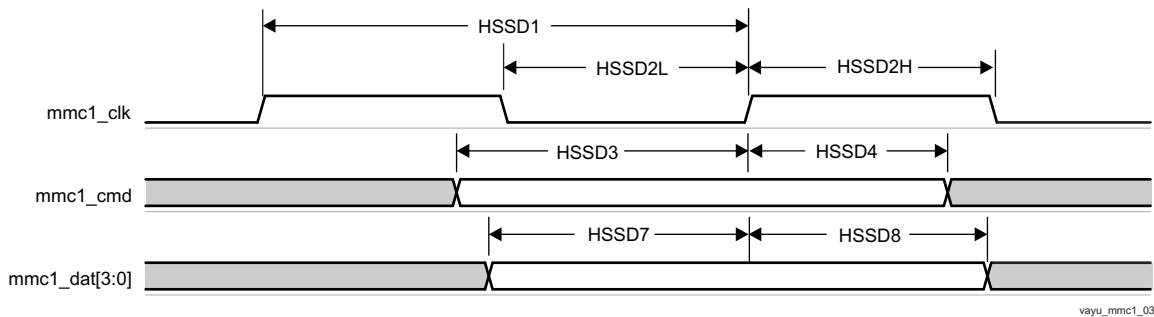

**Figure 5-79. MMC/SD/SDIO in - High Speed - Receiver Mode**

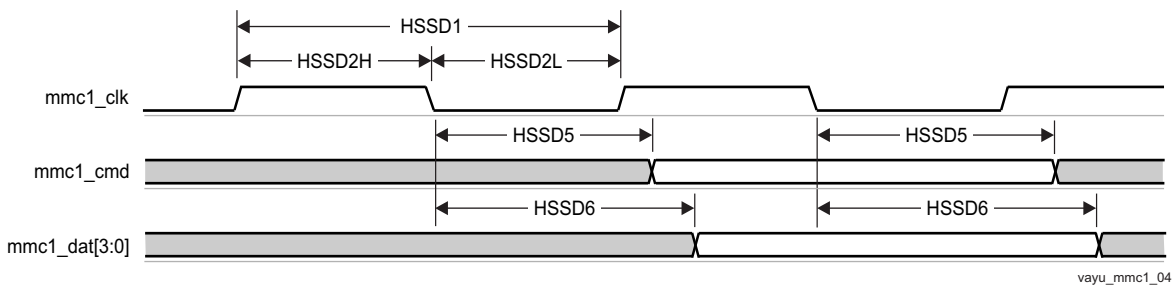

**Figure 5-80. MMC/SD/SDIO in - High Speed - Transmitter Mode**

**5.10.6.19.1.3 SDR12, 4-bit data, half-cycle**

Table 5-125 and Table 5-126 present timing requirements and switching characteristics for MMC1 - SDR12 in receiver and transmitter mode (see Figure 5-81 and Figure 5-82).

**Table 5-125. Timing Requirements for MMC1 - SD Card SDR12 Mode**

NO.	PARAMETER	DESCRIPTION	MODE	MIN	MAX	UNIT
SDR125	$t_{\text{su}(\text{cmdV-clkH})}$	Setup time, mmc1_cmd valid before mmc1_clk rising clock edge		25.99		ns
SDR126	$t_{h(\text{clkH-cmdV})}$	Hold time, mmc1_cmd valid after mmc1_clk rising clock edge		1.6		ns
SDR127	$t_{\text{su}(\text{dV-clkH})}$	Setup time, mmc1_dat[3:0] valid before mmc1_clk rising clock edge		25.99		ns
SDR128	$t_{h(\text{clkH-dV})}$	Hold time, mmc1_dat[3:0] valid after mmc1_clk rising clock edge		1.6		ns

**Table 5-126. Switching Characteristics for MMC1 - SD Card SDR12 Mode**

NO.	PARAMETER	DESCRIPTION	MIN	MAX	UNIT
SDR120	$f_{op}(clk)$	Operating frequency, mmc1_clk		24	MHz
SDR121	$t_w(clkH)$	Pulse duration, mmc1_clk high	0.5P-0.185 (1)		ns
SDR122	$t_w(clkL)$	Pulse duration, mmc1_clk low	0.5P-0.185 (1)		ns
SDR123	$t_d(clkL-cmdV)$	Delay time, mmc1_clk falling clock edge to mmc1_cmd transition	-19.13	16.93	ns
SDR124	$t_d(clkL-dV)$	Delay time, mmc1_clk falling clock edge to mmc1_dat[3:0] transition	-19.13	16.93	ns

(1) P = output mmc1\_clk period in ns

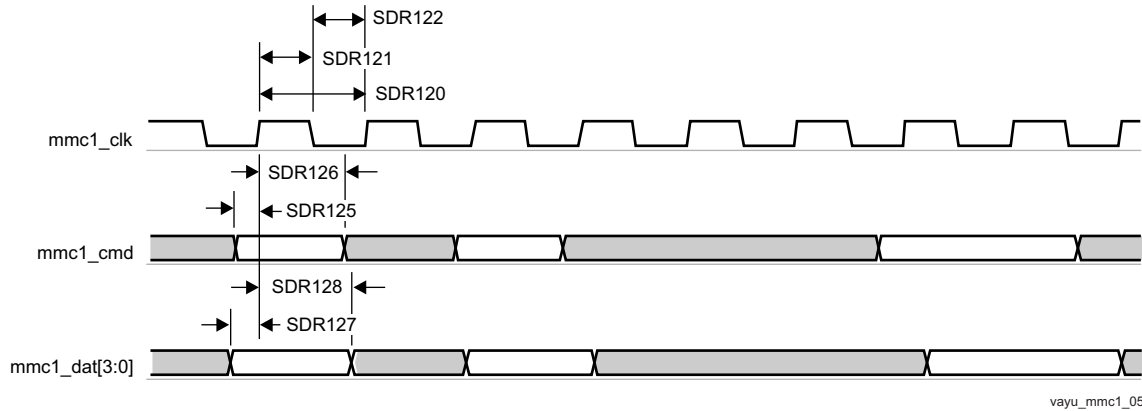

**Figure 5-81. MMC/SD/SDIO in - High Speed SDR12 - Receiver Mode**

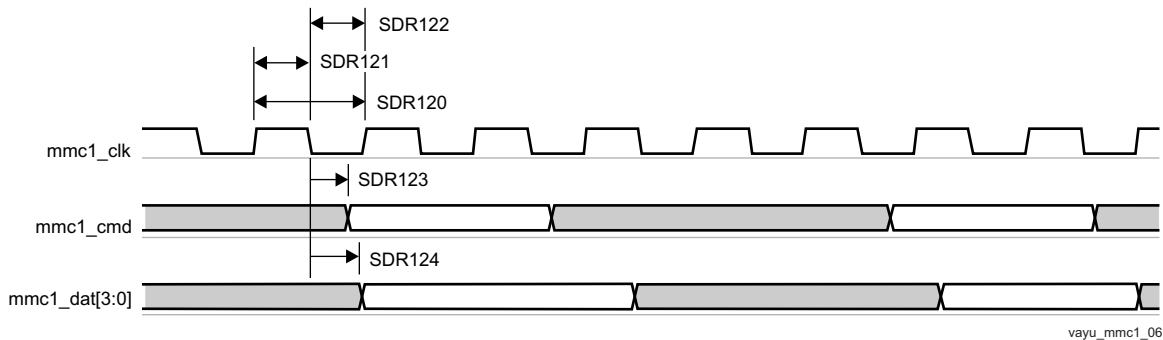

**Figure 5-82. MMC/SD/SDIO in - High Speed SDR12 - Transmitter Mode**

**5.10.6.19.1.4 SDR25, 4-bit data, half-cycle**

Table 5-127 and Table 5-128 present timing requirements and switching characteristics for MMC1 - SDR25 in receiver and transmitter mode (see Figure 5-83 and Figure 5-84).

**Table 5-127. Timing Requirements for MMC1 - SD Card SDR25 Mode**

NO.	PARAMETER	DESCRIPTION	MODE	MIN	MAX	UNIT
SDR253	$t_{su}(cmdV-clkH)$	Setup time, mmc1_cmd valid before mmc1_clk rising clock edge		5.3		ns
SDR254	$t_h(clkH-cmdV)$	Hold time, mmc1_cmd valid after mmc1_clk rising clock edge		1.6		ns
SDR257	$t_{su}(dV-clkH)$	Setup time, mmc1_dat[3:0] valid before mmc1_clk rising clock edge		5.3		ns
SDR258	$t_h(clkH-dV)$	Hold time, mmc1_dat[3:0] valid after mmc1_clk rising clock edge		1.6		ns

**Table 5-128. Switching Characteristics for MMC1 - SD Card SDR25 Mode**

NO.	PARAMETER	DESCRIPTION	MIN	MAX	UNIT
SDR251	$f_{op}(clk)$	Operating frequency, mmc1_clk		48	MHz
SDR252 H	$t_w(clkH)$	Pulse duration, mmc1_clk high	0.5P-0.185 <sup>(1)</sup>		ns
SDR252L	$t_w(clkL)$	Pulse duration, mmc1_clk low	0.5P-0.185 <sup>(1)</sup>		ns
SDR255	$t_d(clkL-cmdV)$	Delay time, mmc1_clk falling clock edge to mmc1_cmd transition	-8.8	6.6	ns
SDR256	$t_d(clkL-dV)$	Delay time, mmc1_clk falling clock edge to mmc1_dat[3:0] transition	-8.8	6.6	ns

(1) P = output mmc1\_clk period in ns

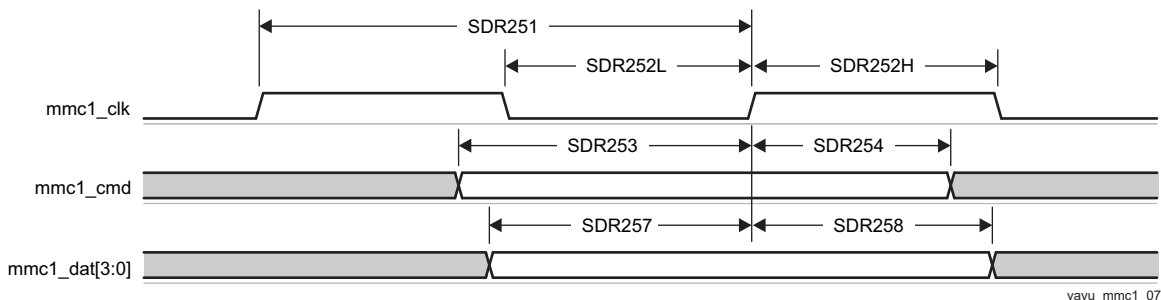

**Figure 5-83. MMC/SD/SDIO in - High Speed SDR25 - Receiver Mode**

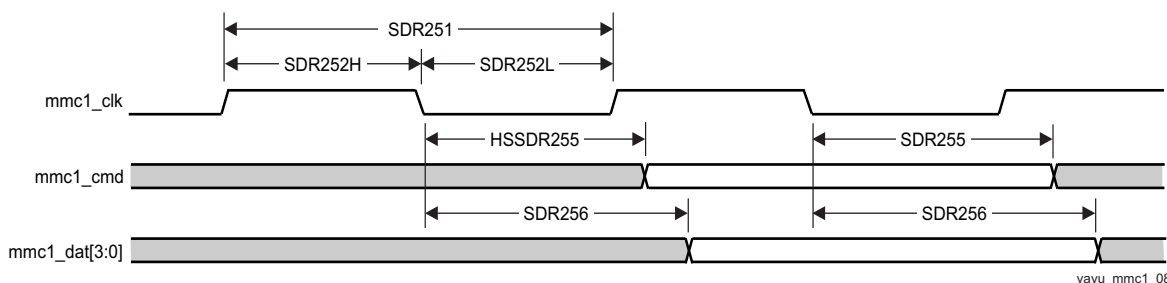

**Figure 5-84. MMC/SD/SDIO in - High Speed SDR25 - Transmitter Mode**

**5.10.6.19.1.5 UHS-I SDR50, 4-bit data, half-cycle**

Table 5-129 and Table 5-130 present timing requirements and switching characteristics for MMC1 - SDR50 in receiver and transmitter mode (see Figure 5-85 and Figure 5-86).

**Table 5-129. Timing Requirements for MMC1 - SD Card SDR50 Mode**

NO.	PARAMETER	DESCRIPTION	MODE	MIN	MAX	UNIT
SDR503	$t_{su}(cmdV-clkH)$	Setup time, mmc1_cmd valid before mmc1_clk rising clock edge		1.48		ns
SDR504	$t_h(clkH-cmdV)$	Hold time, mmc1_cmd valid after mmc1_clk rising clock edge		1.6		ns
SDR507	$t_{su}(dV-clkH)$	Setup time, mmc1_dat[3:0] valid before mmc1_clk rising clock edge		1.48		ns
SDR508	$t_h(clkH-dV)$	Hold time, mmc1_dat[3:0] valid after mmc1_clk rising clock edge		1.6		ns

**Table 5-130. Switching Characteristics for MMC1 - SD Card SDR50 Mode**

NO.	PARAMETER	DESCRIPTION	MIN	MAX	UNIT
SDR501	$f_{op}(clk)$	Operating frequency, mmc1_clk		96	MHz
SDR502 H	$t_w(clkH)$	Pulse duration, mmc1_clk high	0.5P-0.185 <sup>(1)</sup>		ns

**Table 5-130. Switching Characteristics for MMC1 - SD Card SDR50 Mode (continued)**

NO.	PARAMETER	DESCRIPTION	MIN	MAX	UNIT
SDR502L	$t_{w(\text{clkL})}$	Pulse duration, mmc1_clk low	0.5P-0.185 <sup>(1)</sup>		ns
SDR505	$t_{d(\text{clkL-cmdV})}$	Delay time, mmc1_clk falling clock edge to mmc1_cmd transition	-3.66	1.46	ns
SDR506	$t_{d(\text{clkL-dV})}$	Delay time, mmc1_clk falling clock edge to mmc1_dat[3:0] transition	-3.66	1.46	ns

(1) P = output mmc1\_clk period in ns

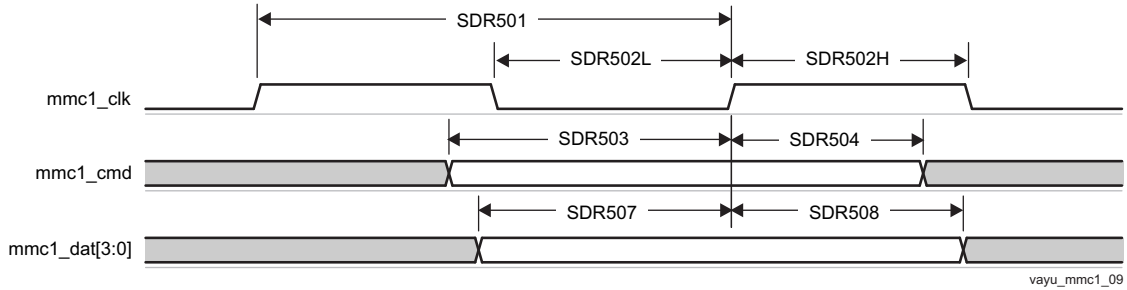

**Figure 5-85. MMC/SD/SDIO in - High Speed SDR50 - Receiver Mode**

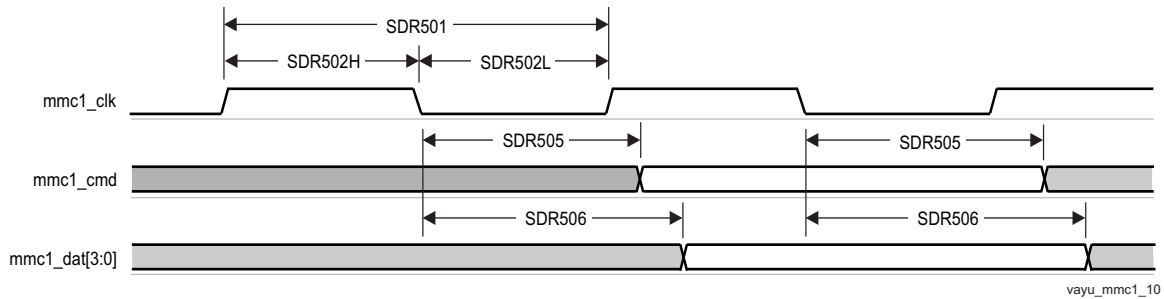

**Figure 5-86. MMC/SD/SDIO in - High Speed SDR50 - Transmitter Mode**

**5.10.6.19.16 UHS-I SDR104, 4-bit data, half-cycle**

Table 5-131 presents timing requirements and switching characteristics for MMC1 - SDR104 in receiver and transmitter mode (see Figure 5-87 and Figure 5-88).

**Table 5-131. Switching Characteristics for MMC1 - SD Card SDR104 Mode**

NO.	PARAMETER	DESCRIPTION	MIN	MAX	UNIT
SDR1041	$f_{op(\text{clk})}$	Operating frequency, mmc1_clk		192	MHz
SDR1042H	$t_{w(\text{clkH})}$	Pulse duration, mmc1_clk high	0.5P-0.185 <sup>(1)</sup>		ns
SDR1042L	$t_{w(\text{clkL})}$	Pulse duration, mmc1_clk low	0.5P-0.185 <sup>(1)</sup>		ns
SDR1045	$t_{d(\text{clkL-cmdV})}$	Delay time, mmc1_clk falling clock edge to mmc1_cmd transition	-1.09	0.49	ns
SDR1046	$t_{d(\text{clkL-dV})}$	Delay time, mmc1_clk falling clock edge to mmc1_dat[3:0] transition	-1.09	0.49	ns

(1) P = output mmc1\_clk period in ns

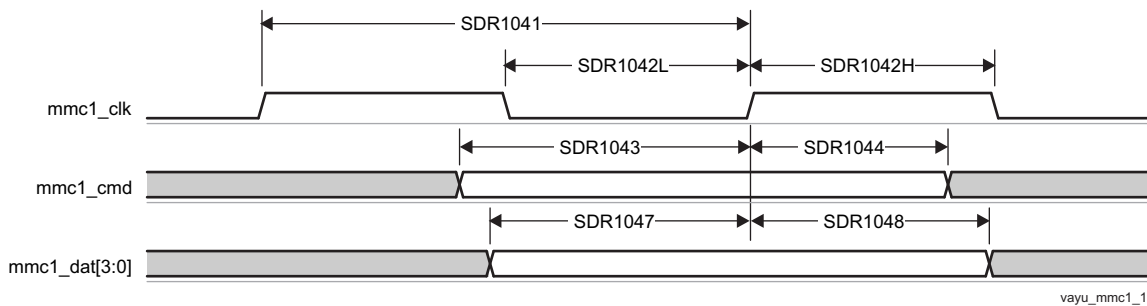

Figure 5-87. MMC/SD/SDIO in - High Speed SDR104 - Receiver Mode

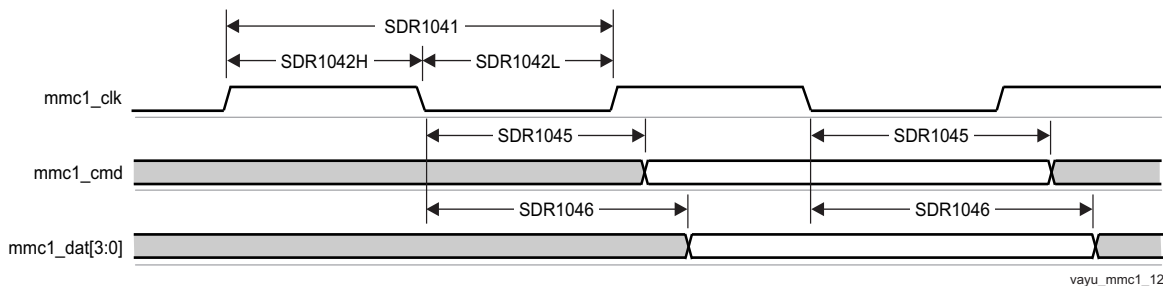

Figure 5-88. MMC/SD/SDIO in - High Speed SDR104 - Transmitter Mode

5.10.6.19.1.7 UHS-I DDR50, 4-bit data

Table 5-132 and Table 5-133 present timing requirements and switching characteristics for MMC1 - DDR50 in receiver and transmitter mode (see Figure 5-89 and Figure 5-90).

Table 5-132. Timing Requirements for MMC1 - SD Card DDR50 Mode

NO.	PARAMETER	DESCRIPTION	MODE	MIN	MAX	UNIT
DDR505	$t_{su(cmdV-clk)}$	Setup time, mmc1_cmd valid before mmc1_clk transition		1.79		ns
DDR506	$t_{h(clk-cmdV)}$	Hold time, mmc1_cmd valid after mmc1_clk transition		1.6		ns
DDR507	$t_{su(dV-clk)}$	Setup time, mmc1_dat[3:0] valid before mmc1_clk transition		1.79		ns
DDR508	$t_{h(clk-dV)}$	Hold time, mmc1_dat[3:0] valid after mmc1_clk transition		1.6		ns

Table 5-133. Switching Characteristics for MMC1 - SD Card DDR50 Mode

NO.	PARAMETER	DESCRIPTION	MIN	MAX	UNIT
DDR500	$f_{op(clk)}$	Operating frequency, mmc1_clk		48	MHz
DDR501	$t_{w(clkH)}$	Pulse duration, mmc1_clk high	0.5P-0.185 <sup>(1)</sup>		ns
DDR502	$t_{w(clkL)}$	Pulse duration, mmc1_clk low	0.5P-0.185 <sup>(1)</sup>		ns
DDR503	$t_{d(clk-cmdV)}$	Delay time, mmc1_clk transition to mmc1_cmd transition	1.225	6.6	ns
DDR504	$t_{d(clk-dV)}$	Delay time, mmc1_clk transition to mmc1_dat[3:0] transition	1.225	6.6	ns

(1) P = output mmc1\_clk period in ns

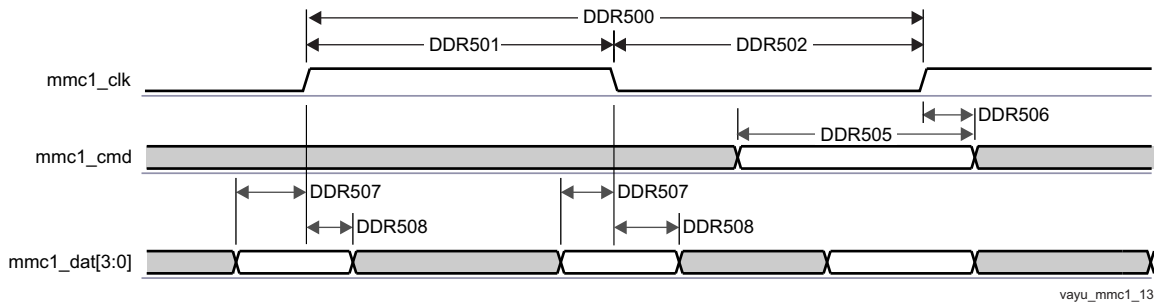

Figure 5-89. SDMMC - High Speed SD - DDR - Data/Command Receive

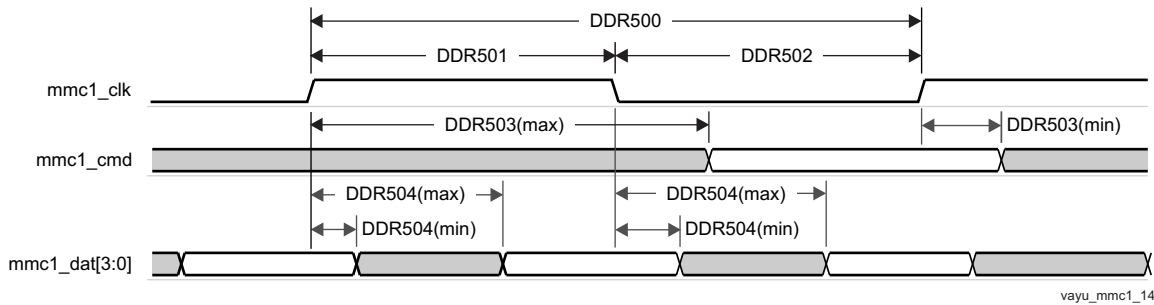

Figure 5-90. SDMMC - High Speed SD - DDR - Data/Command Transmit

**NOTE**

To configure the desired virtual mode the user must set MODESELECT bit and DELAYMODE bit field for each corresponding pad control register.

The pad control registers are presented in [Table 4-33](#) and described in chapter Control Module Chapter in the device TRM.

Virtual IO Timings Modes must be used to ensure some IO timings for MMC1. See [Table 5-33, Modes Summary](#) for a list of IO timings requiring the use of Virtual IO Timings Modes. See [Table 5-134, Virtual Functions Mapping for MMC1](#) for a definition of the Virtual modes.

[Table 5-134](#) presents the values for DELAYMODE bit field.

**Table 5-134. Virtual Functions Mapping for MMC1**

BALL	BALL NAME	Delay Mode Value					MUXMODE[15:0]
		MMC1_VIRTUAL1	MMC1_VIRTUAL2	MMC1_VIRTUAL5	MMC1_VIRTUAL6	MMC1_VIRTUAL7	0
W6	mmc1_clk	11	10	7	6	5	mmc1_clk
W5	mmc1_cmd	11	10	7	6	5	mmc1_cmd
V5	mmc1_dat0	11	10	7	6	5	mmc1_dat0
Y4	mmc1_dat1	11	10	7	6	5	mmc1_dat1
AA5	mmc1_dat2	11	10	7	6	5	mmc1_dat2
Y3	mmc1_dat3	11	10	7	6	5	mmc1_dat3

**NOTE**

To configure the desired manual IO timing mode the user must follow the steps described in *Manual IO Timing Modes* section in the device TRM.

The associated registers to configure are listed in the **CFG REGISTER** column. For more information, see *Control Module* chapter in the device TRM.

---

Manual IO Timings Modes must be used to ensure some IO timings for MMC1. See [Table 5-33, Modes Summary](#) for a list of IO timings requiring the use of Manual IO Timings Modes. See [Table 5-135, Manual Functions Mapping for MMC1](#) for a definition of the Manual modes.

[Table 5-135](#) lists the A\_DELAY and G\_DELAY values needed to calculate the correct values to be set in the CFG\_x registers.

Table 5-135. Manual Functions Mapping for MMC1

BALL	BALL NAME	MMC1_DDR_MANUAL1		MMC1_SDR104_MANUAL1		CFG REGISTER	MUXMODE
		A_DELAY (ps)	G_DELAY (ps)	A_DELAY (ps)	G_DELAY (ps)		0
W6	mmc1_clk	489	0	-	-	CFG_MMC1_CLK_IN	mmc1_clk
W5	mmc1_cmd	0	0	-	-	CFG_MMC1_CMD_IN	mmc1_cmd
V5	mmc1_dat0	374	0	-	-	CFG_MMC1_DAT0_IN	mmc1_dat0
Y4	mmc1_dat1	31	0	-	-	CFG_MMC1_DAT1_IN	mmc1_dat1
AA5	mmc1_dat2	56	0	-	-	CFG_MMC1_DAT2_IN	mmc1_dat2
Y3	mmc1_dat3	0	0	-	-	CFG_MMC1_DAT3_IN	mmc1_dat3
W6	mmc1_clk	1355	0	892	0	CFG_MMC1_CLK_OUT	mmc1_clk
W5	mmc1_cmd	0	0	0	0	CFG_MMC1_CMD_OEN	mmc1_cmd
W5	mmc1_cmd	0	0	0	0	CFG_MMC1_CMD_OUT	mmc1_cmd
V5	mmc1_dat0	0	0	0	0	CFG_MMC1_DAT0_OEN	mmc1_dat0
V5	mmc1_dat0	0	4	0	0	CFG_MMC1_DAT0_OUT	mmc1_dat0
Y4	mmc1_dat1	0	0	0	0	CFG_MMC1_DAT1_OEN	mmc1_dat1
Y4	mmc1_dat1	0	0	0	0	CFG_MMC1_DAT1_OUT	mmc1_dat1
AA5	mmc1_dat2	0	0	0	0	CFG_MMC1_DAT2_OEN	mmc1_dat2
AA5	mmc1_dat2	0	0	0	0	CFG_MMC1_DAT2_OUT	mmc1_dat2
Y3	mmc1_dat3	0	0	0	0	CFG_MMC1_DAT3_OEN	mmc1_dat3
Y3	mmc1_dat3	0	0	0	0	CFG_MMC1_DAT3_OUT	mmc1_dat3

### 5.10.6.19.2 MMC2 — eMMC

MMC2 interface is compliant with the JC64 eMMC Standard v4.5 and it supports the following eMMC applications:

- Standard JC64 SDR, 8-bit data, half cycle
- High Speed JC64 SDR, 8-bit data, half cycle
- High Speed JC64 DDR, 8-bit data
- High Speed HS200 JC64 SDR, 8-bit data, half cycle

#### NOTE

For more information, see *eMMC/SD/SDIO* chapter in the device TRM.

#### 5.10.6.19.2.1 Standard JC64 SDR, 8-bit data, half cycle

Table 5-136 and Table 5-137 present timing requirements and switching characteristics for MMC2 - Standard SDR in receiver and transmitter mode (see Figure 5-91 and Figure 5-92).



**Table 5-136. Timing Requirements for MMC2 - JC64 Standard SDR Mode**

NO.	PARAMETER	DESCRIPTION	MIN	MAX	UNIT
SSDR5	$t_{su(cmdV-clkH)}$	Setup time, mmc2_cmd valid before mmc2_clk rising clock edge	13.19		ns
SSDR6	$t_{h(clkH-cmdV)}$	Hold time, mmc2_cmd valid after mmc2_clk rising clock edge	8.4		ns
SSDR7	$t_{su(dV-clkH)}$	Setup time, mmc2_dat[7:0] valid before mmc2_clk rising clock edge	13.19		ns
SSDR8	$t_{h(clkH-dV)}$	Hold time, mmc2_dat[7:0] valid after mmc2_clk rising clock edge	8.4		ns

**Table 5-137. Switching Characteristics for MMC2 - JC64 Standard SDR Mode**

NO.	PARAMETER	DESCRIPTION	MIN	MAX	UNIT
SSDR1	$f_{op}(clk)$	Operating frequency, mmc2_clk		24	MHz
SSDR2H	$t_w(clkH)$	Pulse duration, mmc2_clk high	0.5P-0.172 <sup>(1)</sup>		ns
SSDR2L	$t_w(clkL)$	Pulse duration, mmc2_clk low	0.5P-0.172 <sup>(1)</sup>		ns
SSDR3	$t_d(clkL-cmdV)$	Delay time, mmc2_clk falling clock edge to mmc2_cmd transition	-16.96	16.96	ns
SSDR4	$t_d(clkL-dV)$	Delay time, mmc2_clk falling clock edge to mmc2_dat[7:0] transition	-16.96	16.96	ns

(1) P = output mmc2\_clk period in ns

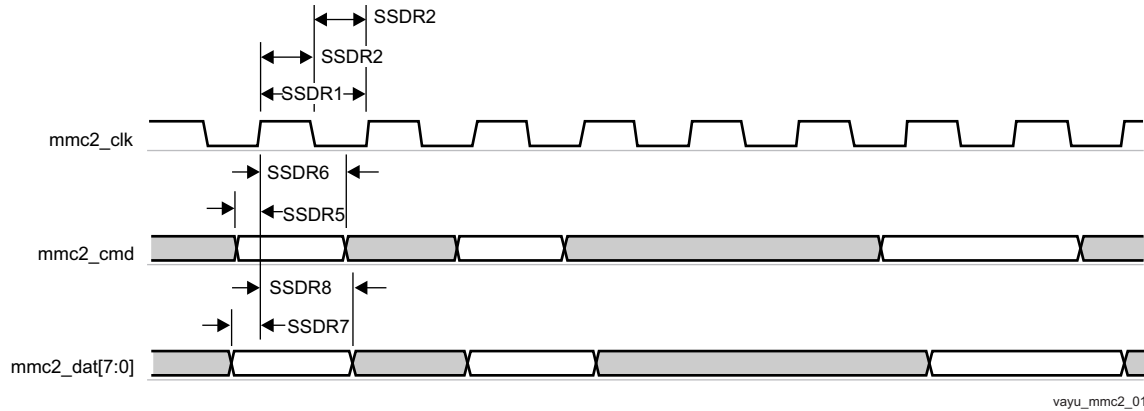

**Figure 5-91. MMC/SD/SDIO in - Standard JC64 - Receiver Mode**

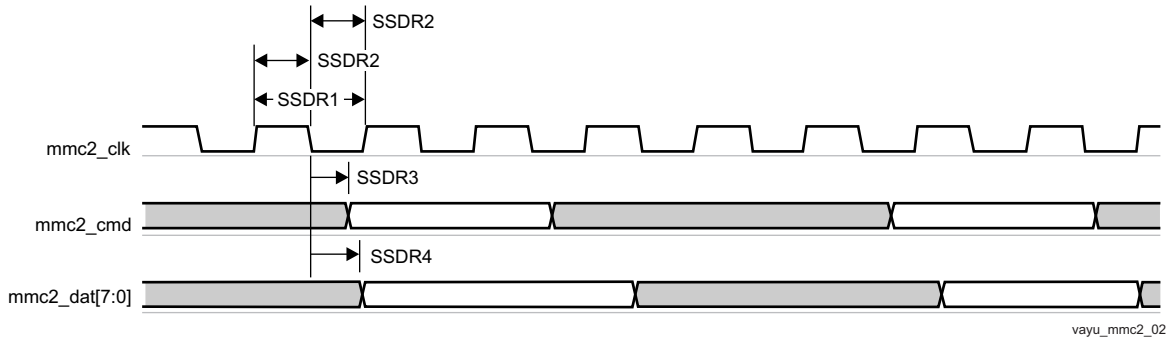

**Figure 5-92. MMC/SD/SDIO in - Standard JC64 - Transmitter Mode**

**5.10.6.19.2.2 High Speed JC64 SDR, 8-bit data, half cycle**

Table 5-138 and Table 5-139 present timing requirements and switching characteristics for MMC2 - High speed SDR in receiver and transmitter mode (see Figure 5-93 and Figure 5-94).

**Table 5-138. Timing Requirements for MMC2 - JC64 High Speed SDR Mode**

NO.	PARAMETER	DESCRIPTION	MIN	MAX	UNIT
JC643	$t_{su}(cmdV-clkH)$	Setup time, mmc2_cmd valid before mmc2_clk rising clock edge	5.6		ns
JC644	$t_h(clkH-cmdV)$	Hold time, mmc2_cmd valid after mmc2_clk rising clock edge	2.6		ns
JC647	$t_{su}(dV-clkH)$	Setup time, mmc2_dat[7:0] valid before mmc2_clk rising clock edge	5.6		ns
JC648	$t_h(clkH-dV)$	Hold time, mmc2_dat[7:0] valid after mmc2_clk rising clock edge	2.6		ns

**Table 5-139. Switching Characteristics for MMC2 - JC64 High Speed SDR Mode**

NO.	PARAMETER	DESCRIPTION	MIN	MAX	UNIT
JC641	$f_{op}(clk)$	Operating frequency, mmc2_clk		48	MHz
JC642H	$t_w(clkH)$	Pulse duration, mmc2_clk high	0.5P-0.172 <sup>(1)</sup>		ns
JC642L	$t_w(clkL)$	Pulse duration, mmc2_clk low	0.5P-0.172 <sup>(1)</sup>		ns
JC645	$t_d(clkL-cmdV)$	Delay time, mmc2_clk falling clock edge to mmc2_cmd transition	-6.64	6.64	ns
JC646	$t_d(clkL-dV)$	Delay time, mmc2_clk falling clock edge to mmc2_dat[7:0] transition	-6.64	6.64	ns

(1) P = output mmc2\_clk period in ns

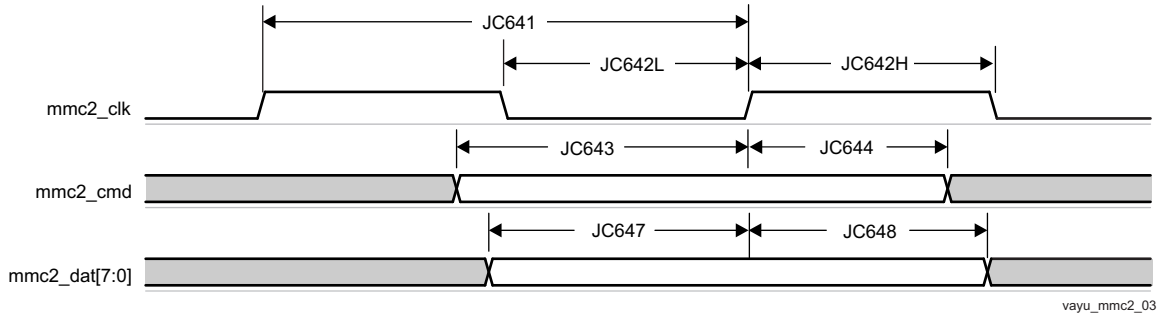

**Figure 5-93. MMC/SD/SDIO in - High Speed JC64 - Receiver Mode**

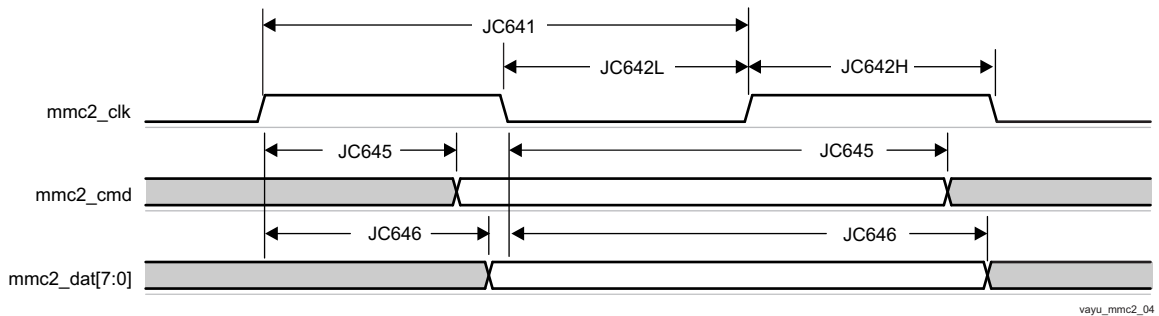

**Figure 5-94. MMC/SD/SDIO in - High Speed JC64 - Transmitter Mode**

**5.10.6.19.2.3 High Speed HS200 JC64 SDR, 8-bit data, half cycle**

Table 5-140 presents timing requirements and switching characteristics for MMC2 - HS200 in receiver and transmitter mode (see Figure 5-95).

**Table 5-140. Switching Characteristics for MMC2 - JEDS84 HS200 Mode**

NO.	PARAMETER	DESCRIPTION	MIN	MAX	UNIT
HS2001	$f_{op}(clk)$	Operating frequency, mmc2_clk		192	MHz
HS2002H	$t_w(clkH)$	Pulse duration, mmc2_clk high	0.5P-0.172 <sup>(1)</sup>		ns
HS2002L	$t_w(clkL)$	Pulse duration, mmc2_clk low	0.5P-0.172 <sup>(1)</sup>		ns
HS2005	$t_d(clkL-cmdV)$	Delay time, mmc2_clk falling clock edge to mmc2_cmd transition	-1.136	0.536	ns
HS2006	$t_d(clkL-dV)$	Delay time, mmc2_clk falling clock edge to mmc2_dat[7:0] transition	-1.136	0.536	ns

(1) P = output mmc2\_clk period in ns

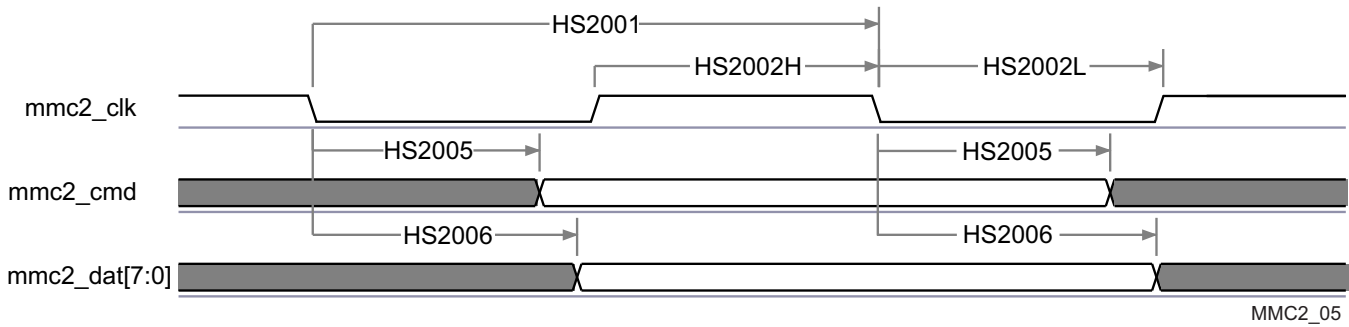

Figure 5-95. eMMC in - HS200 SDR - Transmitter Mode

5.10.6.19.2.4 High Speed JC64 DDR, 8-bit data

Table 5-141 and Table 5-142 present timing requirements and switching characteristics for MMC2 - High speed DDR in receiver and transmitter mode (see Figure 5-96 and Figure 5-97).

Table 5-141. Timing Requirements for MMC2 - JC64 High Speed DDR Mode

NO.	PARAMETER	DESCRIPTION	MODE	MIN	MAX	UNIT
DDR3	$t_{su(cmdV-clk)}$	Setup time, mmc2_cmd valid before mmc2_clk transition		1.8		ns
DDR4	$t_h(clk-cmdV)$	Hold time, mmc2_cmd valid after mmc2_clk transition		1.6		ns
DDR7	$t_{su(dV-clk)}$	Setup time, mmc2_dat[7:0] valid before mmc2_clk transition		1.8		ns
DDR8	$t_h(clk-dV)$	Hold time, mmc2_dat[7:0] valid after mmc2_clk transition		1.6		ns

Table 5-142. Switching Characteristics for MMC2 - JC64 High Speed DDR Mode

NO.	PARAMETER	DESCRIPTION	MIN	MAX	UNIT
DDR1	$f_{op(clk)}$	Operating frequency, mmc2_clk		48	MHz
DDR2H	$t_w(clkH)$	Pulse duration, mmc2_clk high	0.5P-0.172 <sup>(1)</sup>		ns
DDR2L	$t_w(clkL)$	Pulse duration, mmc2_clk low	0.5P-0.172 <sup>(1)</sup>		ns
DDR5	$t_d(clk-cmdV)$	Delay time, mmc2_clk transition to mmc2_cmd transition	2.9	7.14	ns
DDR6	$t_d(clk-dV)$	Delay time, mmc2_clk transition to mmc2_dat[7:0] transition	2.9	7.14	ns

(1) P = output mmc2\_clk period in ns

Table 5-143 and Table 5-144 present timing requirements and switching characteristics for MMC2 - High speed DDR in receiver and transmitter mode During Boot (see Figure 5-96 and Figure 5-97).

Table 5-143. Timing Requirements for MMC2 - JC64 High Speed DDR Mode During Boot

NO.	PARAMETER	DESCRIPTION	MODE	MIN	MAX	UNIT
DDR3	$t_{su(cmdV-clk)}$	Setup time, mmc2_cmd valid before mmc2_clk transition	Boot	1.8		ns
DDR4	$t_h(clk-cmdV)$	Hold time, mmc2_cmd valid after mmc2_clk transition	Boot	1.8 <sup>(1)</sup>		ns
DDR7	$t_{su(dV-clk)}$	Setup time, mmc2_dat[7:0] valid before mmc2_clk transition	Boot	1.8		ns
DDR8	$t_h(clk-dV)$	Hold time, mmc2_dat[7:0] valid after mmc2_clk transition	Boot	1.8 <sup>(1)</sup>		ns

(1) This Hold time requirement is larger than the Hold time provided by a typical eMMC component. Therefore, the trace length between the Device and eMMC component must be sufficiently long enough to ensure that the Hold time is met at the Device.

Table 5-144. Switching Characteristics for MMC2 - JC64 High Speed DDR Mode During Boot

NO.	PARAMETER	DESCRIPTION	MODE	MIN	MAX	UNIT
DDR1	$f_{op(clk)}$	Operating frequency, mmc2_clk	Boot		48	MHz

**Table 5-144. Switching Characteristics for MMC2 - JC64 High Speed DDR Mode During Boot (continued)**

NO.	PARAMETER	DESCRIPTION	MODE	MIN	MAX	UNIT
DDR2H	$t_{w(\text{clkH})}$	Pulse duration, mmc2_clk high	Boot	0.5P-0.172 <sup>(1)</sup>		ns
DDR2L	$t_{w(\text{clkL})}$	Pulse duration, mmc2_clk low	Boot	0.5P-0.172 <sup>(1)</sup>		ns
DDR5	$t_{d(\text{clk-cmdV})}$	Delay time, mmc2_clk transition to mmc2_cmd transition	Boot	2.9	7.14	ns
DDR6	$t_{d(\text{clk-dV})}$	Delay time, mmc2_clk transition to mmc2_dat[7:0] transition	Boot	2.9	7.14	ns

(1) P = output mmc2\_clk period in ns

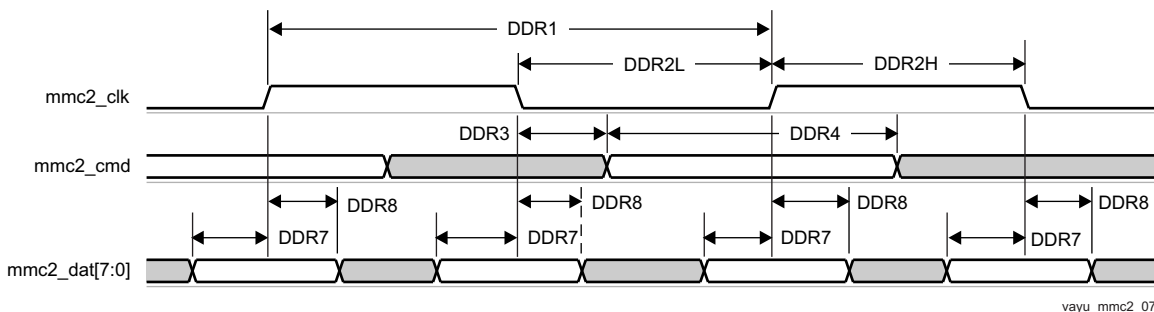

**Figure 5-96. MMC/SD/SDIO in - High Speed DDR JC64 - Receiver Mode**

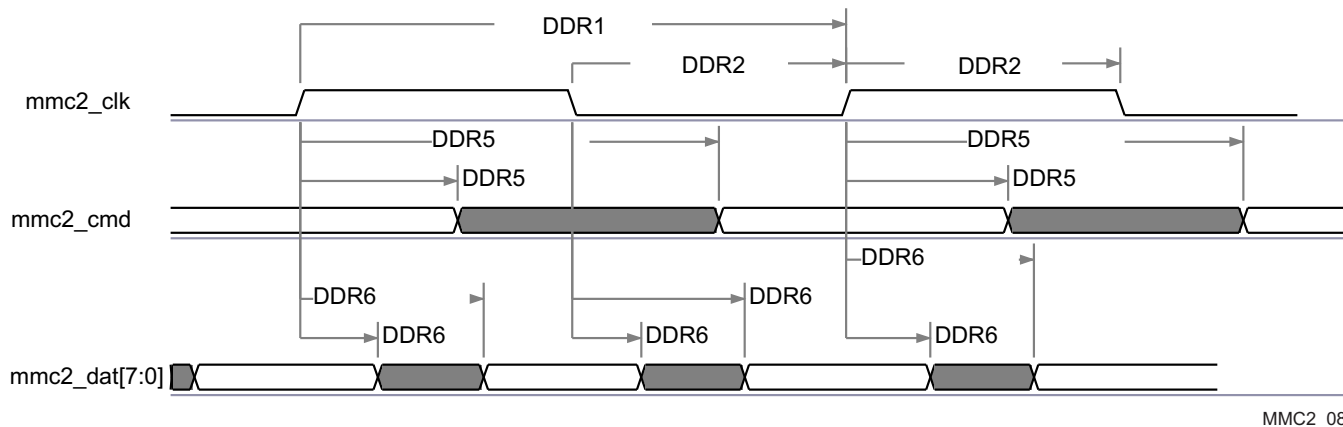

**Figure 5-97. MMC/SD/SDIO in - High Speed DDR JC64 - Transmitter Mode**

**NOTE**

To configure the desired manual IO timing mode the user must follow the steps described in *Manual IO Timing Modes* section in the device TRM.

The associated registers to configure are listed in the **CFG REGISTER** column. For more information, see *Control Module* chapter in the device TRM.

Manual IO Timings Modes must be used to ensure some IO timings for MMC2. See [Table 5-33, Modes Summary](#) for a list of IO timings requiring the use of Manual IO Timings Modes. See [Table 5-145, Manual Functions Mapping for MMC2 with Internal Loopback Clock and for HS200](#) for a definition of the Manual modes.

[Table 5-145](#) lists the A\_DELAY and G\_DELAY values needed to calculate the correct values to be set in the CFG\_x registers.

**Table 5-145. Manual Functions Mapping for MMC2 With Internal Loopback Clock and for HS200**

BALL	BALL NAME	MMC2_DDR_LB_MANUAL1		MMC2_STD_HS_LB_MANUAL1		MMC2_HS200_MANUAL1		CFG REGISTER	MUXMODE 1
		A_DELAY (ps)	G_DELAY (ps)	A_DELAY (ps)	G_DELAY (ps)	A_DELAY (ps)	G_DELAY (ps)		
K7	gpmc_a19	124	0	850	0	-	-	CFG_GPMC_A19_IN	mmc2_dat4
M7	gpmc_a20	62	0	1264	0	-	-	CFG_GPMC_A20_IN	mmc2_dat5
J5	gpmc_a21	0	0	786	0	-	-	CFG_GPMC_A21_IN	mmc2_dat6
K6	gpmc_a22	0	0	902	0	-	-	CFG_GPMC_A22_IN	mmc2_dat7
J7	gpmc_a23	645	3054	0	2764	-	-	CFG_GPMC_A23_IN	mmc2_clk
J4	gpmc_a24	48	0	1185	0	-	-	CFG_GPMC_A24_IN	mmc2_dat0
J6	gpmc_a25	0	0	670	0	-	-	CFG_GPMC_A25_IN	mmc2_dat1
H4	gpmc_a26	0	0	972	0	-	-	CFG_GPMC_A26_IN	mmc2_dat2
H5	gpmc_a27	0	0	1116	0	-	-	CFG_GPMC_A27_IN	mmc2_dat3
H6	gpmc_cs1	0	0	250	0	-	-	CFG_GPMC_CS1_IN	mmc2_cmd
K7	gpmc_a19	0	0	0	0	384	0	CFG_GPMC_A19_OEN	mmc2_dat4
K7	gpmc_a19	135	0	0	0	350	174	CFG_GPMC_A19_OUT	mmc2_dat4
M7	gpmc_a20	0	0	0	0	410	0	CFG_GPMC_A20_OEN	mmc2_dat5
M7	gpmc_a20	47	0	0	0	335	0	CFG_GPMC_A20_OUT	mmc2_dat5
J5	gpmc_a21	0	0	0	0	468	0	CFG_GPMC_A21_OEN	mmc2_dat6
J5	gpmc_a21	101	0	0	0	339	0	CFG_GPMC_A21_OUT	mmc2_dat6
K6	gpmc_a22	0	0	0	0	676	0	CFG_GPMC_A22_OEN	mmc2_dat7
K6	gpmc_a22	30	0	0	0	219	0	CFG_GPMC_A22_OUT	mmc2_dat7
J7	gpmc_a23	423	0	0	0	1062	154	CFG_GPMC_A23_OUT	mmc2_clk
J4	gpmc_a24	0	0	0	0	640	0	CFG_GPMC_A24_OEN	mmc2_dat0
J4	gpmc_a24	0	0	0	0	150	0	CFG_GPMC_A24_OUT	mmc2_dat0
J6	gpmc_a25	0	0	0	0	356	0	CFG_GPMC_A25_OEN	mmc2_dat1
J6	gpmc_a25	0	0	0	0	150	0	CFG_GPMC_A25_OUT	mmc2_dat1
H4	gpmc_a26	0	0	0	0	579	0	CFG_GPMC_A26_OEN	mmc2_dat2
H4	gpmc_a26	0	0	0	0	200	0	CFG_GPMC_A26_OUT	mmc2_dat2
H5	gpmc_a27	0	0	0	0	435	0	CFG_GPMC_A27_OEN	mmc2_dat3
H5	gpmc_a27	0	0	0	0	236	0	CFG_GPMC_A27_OUT	mmc2_dat3
H6	gpmc_cs1	0	0	0	0	759	0	CFG_GPMC_CS1_OEN	mmc2_cmd
H6	gpmc_cs1	0	0	0	0	372	0	CFG_GPMC_CS1_OUT	mmc2_cmd



### 5.10.6.19.3 MMC3 and MMC4—SDIO/SD

MMC3 and MMC4 interfaces are compliant with the SDIO3.0 Standard v1.0, SD Part E1 and for generic SDIO devices, it supports the following applications:

- MMC3 8-bit data and MMC4 4-bit data, SD Default speed, SDR
- MMC3 8-bit data and MMC4 4-bit data, SD High speed, SDR
- MMC3 8-bit data and MMC4 4-bit data, UHS-1 SDR12 (SD Standard v3.01), 4-bit data, SDR, half cycle
- MMC3 8-bit data and MMC4 4-bit data, UHS-I SDR25 (SD Standard v3.01), 4-bit data, SDR, half cycle
- MMC3 8-bit data, UHS-I SDR50

---

#### NOTE

The eMMC/SD/SDIOj (j = 3 to 4) controller is also referred to as MMCj.

---



---

#### NOTE

For more information, see *eMMC/SD/SDIO* chapter in the device TRM.

---

#### 5.10.6.19.3.1 MMC3 and MMC4, SD Default Speed

Figure 5-98, Figure 5-99, and Table 5-146 through Table 5-149 present timing requirements and switching characteristics for MMC3 and MMC4 - SD Default speed in receiver and transmitter mode.

**Table 5-146. Timing Requirements for MMC3 - Default Speed Mode <sup>(1)</sup>**

NO.	PARAMETER	DESCRIPTION	MIN	MAX	UNIT
DS5	$t_{su(cmdV-clkH)}$	Setup time, mmc3_cmd valid before mmc3_clk rising clock edge	5.11		ns
DS6	$t_h(clkH-cmdV)$	Hold time, mmc3_cmd valid after mmc3_clk rising clock edge	20.46		ns
DS7	$t_{su(dV-clkH)}$	Setup time, mmc3_dat[i:0] valid before mmc3_clk rising clock edge	5.11		ns
DS8	$t_h(clkH-dV)$	Hold time, mmc3_dat[i:0] valid after mmc3_clk rising clock edge	20.46		ns

(1) i in [i:0] = 7

**Table 5-147. Switching Characteristics for MMC3 - SD/SDIO Default Speed Mode <sup>(2)</sup>**

NO.	PARAMETER	DESCRIPTION	MIN	MAX	UNIT
DS0	$f_{op(clk)}$	Operating frequency, mmc3_clk		24	MHz
DS1	$t_w(clkH)$	Pulse duration, mmc3_clk high	0.5P- 0.270 <sup>(2)</sup>		ns
DS2	$t_w(clkL)$	Pulse duration, mmc3_clk low	0.5P- 0.270 <sup>(2)</sup>		ns
DS3	$t_d(clkL-cmdV)$	Delay time, mmc3_clk falling clock edge to mmc3_cmd transition	-14.93	14.93	ns
DS4	$t_d(clkL-dV)$	Delay time, mmc3_clk falling clock edge to mmc3_dat[i:0] transition	-14.93	14.93	ns

(1) P = output mmc3\_clk period in ns

(2) i in [i:0] = 7

**Table 5-148. Timing Requirements for MMC4 - Default Speed Mode <sup>(1)</sup>**

NO.	PARAMETER	DESCRIPTION	MIN	MAX	UNIT
DS5	$t_{su(cmdV-clkH)}$	Setup time, mmc4_cmd valid before mmc4_clk rising clock edge	5.11		ns
DS6	$t_h(clkH-cmdV)$	Hold time, mmc4_cmd valid after mmc4_clk rising clock edge	20.46		ns
DS7	$t_{su(dV-clkH)}$	Setup time, mmc4_dat[i:0] valid before mmc4_clk rising clock edge	5.11		ns
DS8	$t_h(clkH-dV)$	Hold time, mmc4_dat[i:0] valid after mmc4_clk rising clock edge	20.46		ns



(1)  $i$  in  $[i:0] = 3$

**Table 5-149. Switching Characteristics for MMC4 - Default Speed Mode <sup>(2)</sup>**

NO.	PARAMETER	DESCRIPTION	MIN	MAX	UNIT
DS0	$f_{op}(clk)$	Operating frequency, mmc4_clk		24	MHz
DS1	$t_w(clkH)$	Pulse duration, mmc4_clk high	0.5P-0.270 <sup>(1)</sup>		ns
DS2	$t_w(clkL)$	Pulse duration, mmc4_clk low	0.5P-0.270 <sup>(1)</sup>		ns
DS3	$t_d(clkL-cmdV)$	Delay time, mmc4_clk falling clock edge to mmc4_cmd transition	-14.93	14.93	ns
DS4	$t_d(clkL-dV)$	Delay time, mmc4_clk falling clock edge to mmc4_dat[i:0] transition	-14.93	14.93	ns

(1) P = output mmc4\_clk period in ns

(2)  $i$  in  $[i:0] = 3$

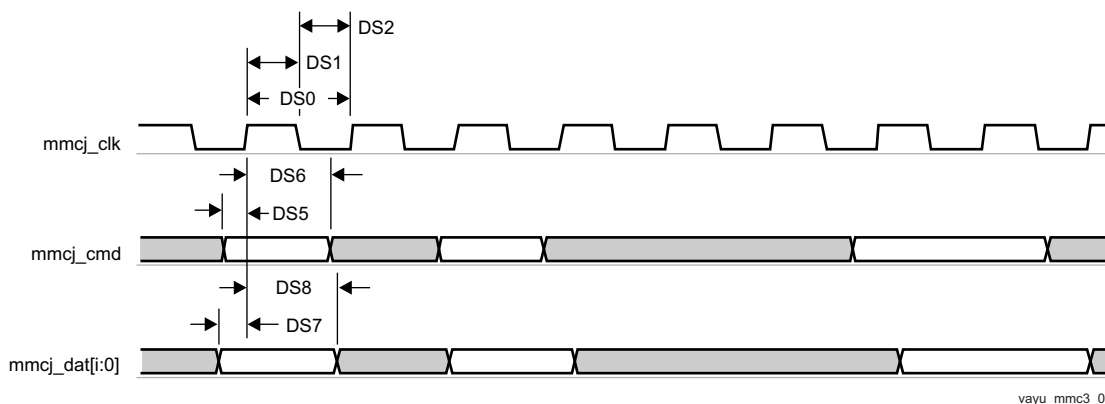

**Figure 5-98. MMC/SD/SDIOj in - Default Speed - Receiver Mode**

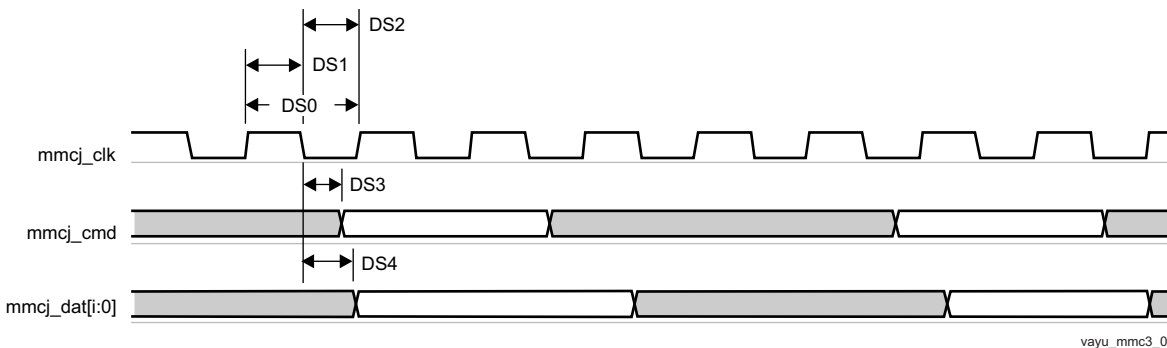

**Figure 5-99. MMC/SD/SDIOj in - Default Speed - Transmitter Mode**

**5.10.6.19.3.2 MMC3 and MMC4, SD High Speed**

Figure 5-100, Figure 5-101, and Table 5-150 through Table 5-153 present timing requirements and switching characteristics for MMC3 and MMC4 - SD and SDIO High speed in receiver and transmitter mode.

**Table 5-150. Timing Requirements for MMC3 - SD/SDIO High Speed Mode <sup>(1)</sup>**

NO.	PARAMETER	DESCRIPTION	MIN	MAX	UNIT
HS3	$t_{su}(cmdV-clkH)$	Setup time, mmc3_cmd valid before mmc3_clk rising clock edge	5.3		ns
HS4	$t_h(clkH-cmdV)$	Hold time, mmc3_cmd valid after mmc3_clk rising clock edge	2.6		ns
HS7	$t_{su}(dV-clkH)$	Setup time, mmc3_dat[i:0] valid before mmc3_clk rising clock edge	5.3		ns

**Table 5-150. Timing Requirements for MMC3 - SD/SDIO High Speed Mode <sup>(1)</sup> (continued)**

NO.	PARAMETER	DESCRIPTION	MIN	MAX	UNIT
HS8	$t_{h(\text{clkH-dV})}$	Hold time, mmc3_dat[i:0] valid after mmc3_clk rising clock edge	2.6		ns

(1) i in [i:0] = 7

**Table 5-151. Switching Characteristics for MMC3 - SD/SDIO High Speed Mode <sup>(2)</sup>**

NO.	PARAMETER	DESCRIPTION	MIN	MAX	UNIT
HS1	$f_{op(\text{clk})}$	Operating frequency, mmc3_clk		48	MHz
HS2H	$t_{w(\text{clkH})}$	Pulse duration, mmc3_clk high	0.5P-0.270 <sup>(1)</sup>		ns
HS2L	$t_{w(\text{clkL})}$	Pulse duration, mmc3_clk low	0.5P-0.270 <sup>(1)</sup>		ns
HS5	$t_{d(\text{clkL-cmdV})}$	Delay time, mmc3_clk falling clock edge to mmc3_cmd transition	-7.6	3.6	ns
HS6	$t_{d(\text{clkL-dV})}$	Delay time, mmc3_clk falling clock edge to mmc3_dat[i:0] transition	-7.6	3.6	ns

(1) P = output mmc3\_clk period in ns

(2) i in [i:0] = 7

**Table 5-152. Timing Requirements for MMC4 - High Speed Mode <sup>(1)</sup>**

NO.	PARAMETER	DESCRIPTION	MIN	MAX	UNIT
HS3	$t_{su(\text{cmdV-clkH})}$	Setup time, mmc4_cmd valid before mmc4_clk rising clock edge	5.3		ns
HS4	$t_{h(\text{clkH-cmdV})}$	Hold time, mmc4_cmd valid after mmc4_clk rising clock edge	1.6		ns
HS7	$t_{su(\text{dV-clkH})}$	Setup time, mmc4_dat[i:0] valid before mmc4_clk rising clock edge	5.3		ns
HS8	$t_{h(\text{clkH-dV})}$	Hold time, mmc4_dat[i:0] valid after mmc4_clk rising clock edge	1.6		ns

(1) i in [i:0] = 3

**Table 5-153. Switching Characteristics for MMC4 - High Speed Mode <sup>(2)</sup>**

NO.	PARAMETER	DESCRIPTION	MIN	MAX	UNIT
HS1	$f_{op(\text{clk})}$	Operating frequency, mmc4_clk		48	MHz
HS2H	$t_{w(\text{clkH})}$	Pulse duration, mmc4_clk high	0.5P-0.270 <sup>(1)</sup>		ns
HS2L	$t_{w(\text{clkL})}$	Pulse duration, mmc4_clk low	0.5P-0.270 <sup>(1)</sup>		ns
HS5	$t_{d(\text{clkL-cmdV})}$	Delay time, mmc4_clk falling clock edge to mmc4_cmd transition	-8.8	6.6	ns
HS6	$t_{d(\text{clkL-dV})}$	Delay time, mmc4_clk falling clock edge to mmc4_dat[i:0] transition	-8.8	6.6	ns

(1) P = output mmc4\_clk period in ns

(2) i in [i:0] = 3

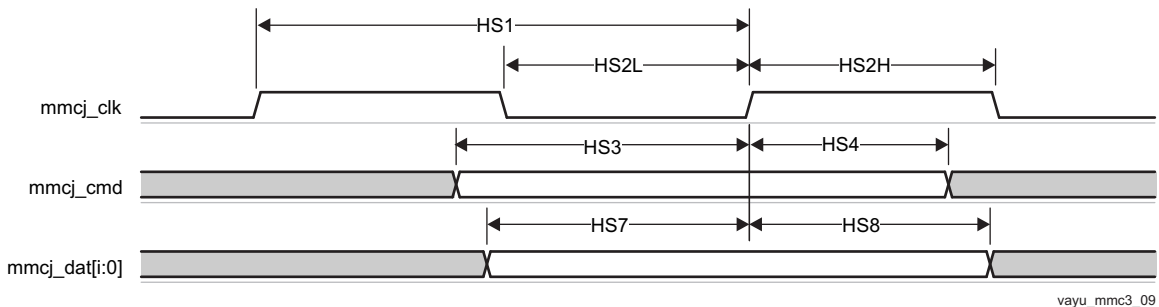

**Figure 5-100. MMC/SD/SDIOj in - High Speed - Receiver Mode**

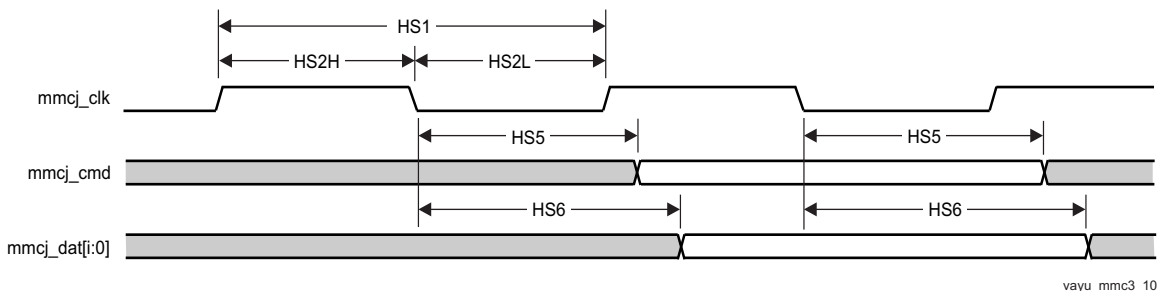

Figure 5-101. MMC/SD/SDIOj in - High Speed - Transmitter Mode

5.10.6.19.3.3 MMC3 and MMC4, SD and SDIO SDR12 Mode

Figure 5-102, Figure 5-103, and Table 5-154 through Table 5-157 present timing requirements and switching characteristics for MMC3 and MMC4 - SD and SDIO SDR12 in receiver and transmitter mode.

Table 5-154. Timing Requirements for MMC3 - SDR12 Mode <sup>(1)</sup>

NO.	PARAMETER	DESCRIPTION	MIN	MAX	UNIT
SDR125	$t_{su(cmdV-clkH)}$	Setup time, mmc3_cmd valid before mmc3_clk rising clock edge	25.99		ns
SDR126	$t_{h(clkH-cmdV)}$	Hold time, mmc3_cmd valid after mmc3_clk rising clock edge	1.6		ns
SDR127	$t_{su(dV-clkH)}$	Setup time, mmc3_dat[i:0] valid before mmc3_clk rising clock edge	25.99		ns
SDR128	$t_{h(clkH-dV)}$	Hold time, mmc3_dat[i:0] valid after mmc3_clk rising clock edge	1.6		ns

(1) i in [i:0] = 7

Table 5-155. Switching Characteristics for MMC3 - SDR12 Mode <sup>(2)</sup>

NO.	PARAMETER	DESCRIPTION	MIN	MAX	UNIT
SDR120	$f_{op(clk)}$	Operating frequency, mmc3_clk		24	MHz
SDR121	$t_{w(clkH)}$	Pulse duration, mmc3_clk high	0.5P-0.270 <sup>(1)</sup>		ns
SDR122	$t_{w(clkL)}$	Pulse duration, mmc3_clk low	0.5P-0.270 <sup>(1)</sup>		ns
SDR123	$t_{d(clkL-cmdV)}$	Delay time, mmc3_clk falling clock edge to mmc3_cmd transition	-19.13	16.93	ns
SDR124	$t_{d(clkL-dV)}$	Delay time, mmc3_clk falling clock edge to mmc3_dat[i:0] transition	-19.13	16.93	ns

(1) P = output mmc3\_clk period in ns

(2) i in [i:0] = 7

Table 5-156. Timing Requirements for MMC4 - SDR12 Mode <sup>(1)</sup>

NO.	PARAMETER	DESCRIPTION	MIN	MAX	UNIT
SDR125	$t_{su(cmdV-clkH)}$	Setup time, mmc4_cmd valid before mmc4_clk rising clock edge	25.99		ns
SDR126	$t_{h(clkH-cmdV)}$	Hold time, mmc4_cmd valid after mmc4_clk rising clock edge	1.6		ns
SDR127	$t_{su(dV-clkH)}$	Setup time, mmc4_dat[i:0] valid before mmc4_clk rising clock edge	25.99		ns
SDR128	$t_{h(clkH-dV)}$	Hold time, mmc4_dat[i:0] valid after mmc4_clk rising clock edge	1.6		ns

(1) j in [i:0] = 3

Table 5-157. Switching Characteristics for MMC4 - SDR12 Mode <sup>(2)</sup>

NO.	PARAMETER	DESCRIPTION	MIN	MAX	UNIT
SDR120	$f_{op(clk)}$	Operating frequency, mmc4_clk		24	MHz
SDR121	$t_{w(clkH)}$	Pulse duration, mmc4_clk high	0.5P-0.270 <sup>(1)</sup>		ns
SDR122	$t_{w(clkL)}$	Pulse duration, mmc4_clk low	0.5P-0.270 <sup>(1)</sup>		ns
SDR125	$t_{d(clkL-cmdV)}$	Delay time, mmc4_clk falling clock edge to mmc4_cmd transition	-19.13	16.93	ns

**Table 5-157. Switching Characteristics for MMC4 - SDR12 Mode <sup>(2)</sup> (continued)**

NO.	PARAMETER	DESCRIPTION	MIN	MAX	UNIT
SDR126	$t_{d(\text{clkL-dv})}$	Delay time, mmc4_clk falling clock edge to mmc4_dat[i:0] transition	-19.13	16.93	ns

(1) P = output mmc4\_clk period in ns

(2) j in [i:0] = 3

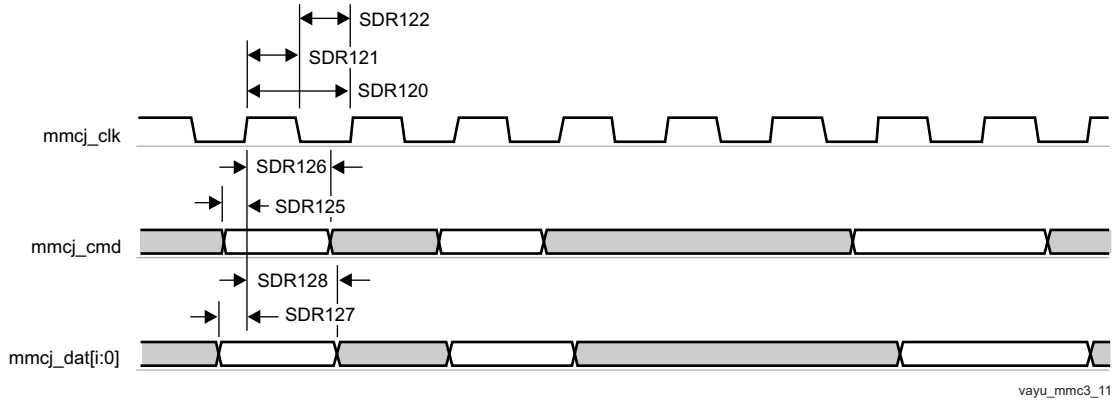

**Figure 5-102. MMC/SD/SDIOj in - SDR12 - Receiver Mode**

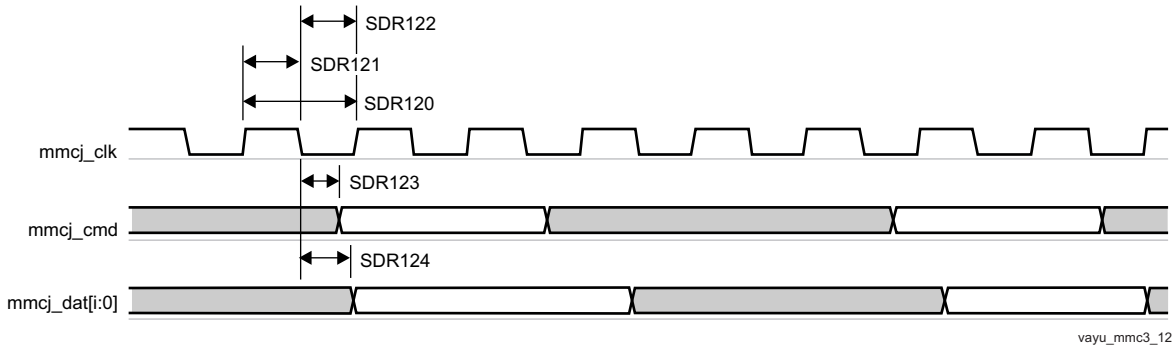

**Figure 5-103. MMC/SD/SDIOj in - SDR12 - Transmitter Mode**

**5.10.6.19.3.4 MMC3 and MMC4, SD SDR25 Mode**

Figure 5-104, Figure 5-105, and Table 5-158 through Table 5-161 present timing requirements and switching characteristics for MMC3 and MMC4 - SD and SDIO SDR25 in receiver and transmitter mode.

**Table 5-158. Timing Requirements for MMC3 - SDR25 Mode <sup>(1)</sup>**

NO.	PARAMETER	DESCRIPTION	MIN	MAX	UNIT
SDR253	$t_{su(\text{cmdV-clkH})}$	Setup time, mmc3_cmd valid before mmc3_clk rising clock edge	5.3		ns
SDR254	$t_{h(\text{clkH-cmdV})}$	Hold time, mmc3_cmd valid after mmc3_clk rising clock edge	1.6		ns
SDR257	$t_{su(\text{dV-clkH})}$	Setup time, mmc3_dat[i:0] valid before mmc3_clk rising clock edge	5.3		ns
SDR258	$t_{h(\text{clkH-dV})}$	Hold time, mmc3_dat[i:0] valid after mmc3_clk rising clock edge	1.6		ns

(1) i in [i:0] = 7

**Table 5-159. Switching Characteristics for MMC3 - SDR25 Mode <sup>(2)</sup>**

NO.	PARAMETER	DESCRIPTION	MIN	MAX	UNIT
SDR251	$f_{op(\text{clk})}$	Operating frequency, mmc3_clk		48	MHz
SDR252 H	$t_{w(\text{clkH})}$	Pulse duration, mmc3_clk high	0.5P <sup>(1)</sup> - 0.270		ns

**Table 5-159. Switching Characteristics for MMC3 - SDR25 Mode <sup>(2)</sup> (continued)**

NO.	PARAMETER	DESCRIPTION	MIN	MAX	UNIT
SDR252L	$t_{w(\text{clkL})}$	Pulse duration, mmc3_clk low	0.5P <sup>(1)</sup> - 0.270		ns
SDR255	$t_{d(\text{clkL-cmdV})}$	Delay time, mmc3_clk falling clock edge to mmc3_cmd transition	-8.8	6.6	ns
SDR256	$t_{d(\text{clkL-dV})}$	Delay time, mmc3_clk falling clock edge to mmc3_dat[i:0] transition	-8.8	6.6	ns

(1) P = output mmc3\_clk period in ns

(2) i in [i:0] = 7

**Table 5-160. Timing Requirements for MMC4 - SDR25 Mode <sup>(1)</sup>**

NO.	PARAMETER	DESCRIPTION	MIN	MAX	UNIT
SDR255	$t_{su(\text{cmdV-clkH})}$	Setup time, mmc4_cmd valid before mmc4_clk rising clock edge	5.3		ns
SDR256	$t_{h(\text{clkH-cmdV})}$	Hold time, mmc4_cmd valid after mmc4_clk rising clock edge	1.6		ns
SDR257	$t_{su(\text{dV-clkH})}$	Setup time, mmc4_dat[i:0] valid before mmc4_clk rising clock edge	5.3		ns
SDR258	$t_{h(\text{clkH-dV})}$	Hold time, mmc4_dat[i:0] valid after mmc4_clk rising clock edge	1.6		ns

(1) i in [i:0] = 3

**Table 5-161. Switching Characteristics for MMC4 - SDR25 Mode <sup>(2)</sup>**

NO.	PARAMETER	DESCRIPTION	MIN	MAX	UNIT
SDR251	$f_{op(\text{clk})}$	Operating frequency, mmc4_clk		48	MHz
SDR252 H	$t_{w(\text{clkH})}$	Pulse duration, mmc4_clk high	0.5P- 0.270 <sup>(1)</sup>		ns
SDR252L	$t_{w(\text{clkL})}$	Pulse duration, mmc4_clk low	0.5P- 0.270 <sup>(1)</sup>		ns
SDR255	$t_{d(\text{clkL-cmdV})}$	Delay time, mmc4_clk falling clock edge to mmc4_cmd transition	-8.8	6.6	ns
SDR256	$t_{d(\text{clkL-dV})}$	Delay time, mmc4_clk falling clock edge to mmc4_dat[i:0] transition	-8.8	6.6	ns

(1) P = output mmc4\_clk period in ns

(2) i in [i:0] = 3

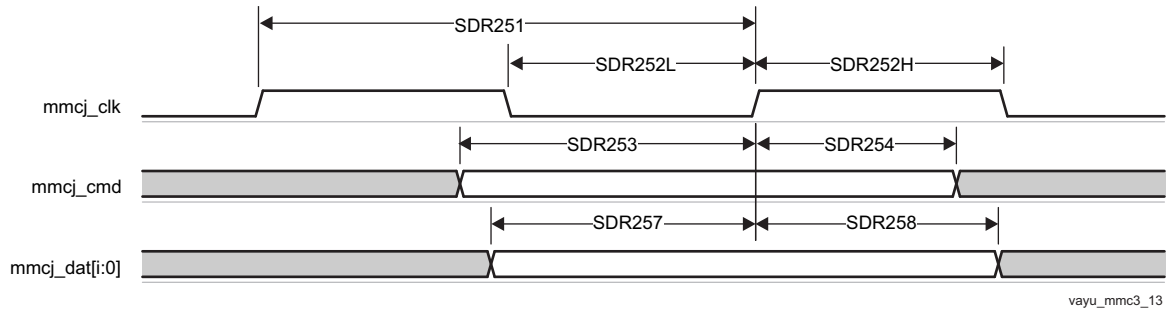

vayu\_mmc3\_13

**Figure 5-104. MMC/SD/SDIOj in - SDR25 - Receiver Mode**

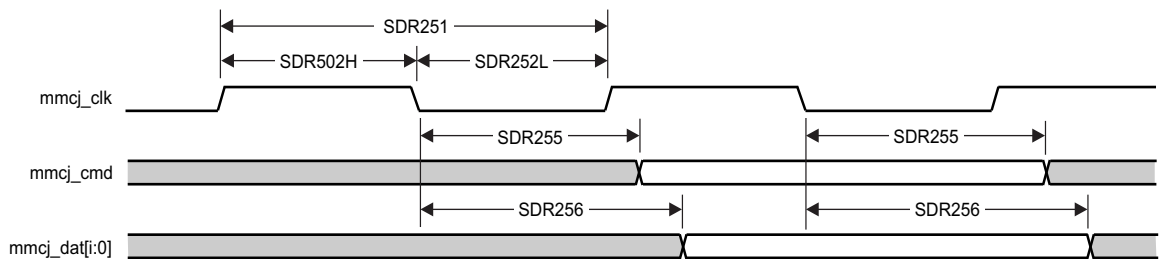

vayu\_mmc3\_14

**Figure 5-105. MMC/SD/SDIOj in - SDR25 - Transmitter Mode**

5.10.6.19.3.5 MMC3 SDIO High Speed UHS-I SDR50 Mode, Half Cycle

Figure 5-106, Figure 5-107, Table 5-162, and Table 5-163 present timing requirements and switching characteristics for MMC3 - SDIO High speed SDR50 in receiver and transmitter mode.

Table 5-162. Timing Requirements for MMC3 - SDR50 Mode <sup>(1)</sup>

NO.	PARAMETER	DESCRIPTION	MIN	MAX	UNIT
SDR503	$t_{su}(cmdV-clkH)$	Setup time, mmc3_cmd valid before mmc3_clk rising clock edge	1.48		ns
SDR504	$t_h(clkH-cmdV)$	Hold time, mmc3_cmd valid after mmc3_clk rising clock edge	1.6		ns
SDR507	$t_{su}(dV-clkH)$	Setup time, mmc3_dat[i:0] valid before mmc3_clk rising clock edge	1.48		ns
SDR508	$t_h(clkH-dV)$	Hold time, mmc3_dat[i:0] valid after mmc3_clk rising clock edge	1.6		ns

(1) i in [i:0] = 7

Table 5-163. Switching Characteristics for MMC3 - SDR50 Mode <sup>(2)</sup>

NO.	PARAMETER	DESCRIPTION	MIN	MAX	UNIT
SDR501	$f_{op}(clk)$	Operating frequency, mmc3_clk		96	MHz
SDR502H	$t_w(clkH)$	Pulse duration, mmc3_clk high	0.5P-0.270 <sup>(1)</sup>		ns
SDR502L	$t_w(clkL)$	Pulse duration, mmc3_clk low	0.5P-0.270 <sup>(1)</sup>		ns
SDR505	$t_d(clkL-cmdV)$	Delay time, mmc3_clk falling clock edge to mmc3_cmd transition	-3.66	1.46	ns
SDR506	$t_d(clkL-dV)$	Delay time, mmc3_clk falling clock edge to mmc3_dat[i:0] transition	-3.66	1.46	ns

(1) P = output mmc3\_clk period in ns

(2) i in [i:0] = 7

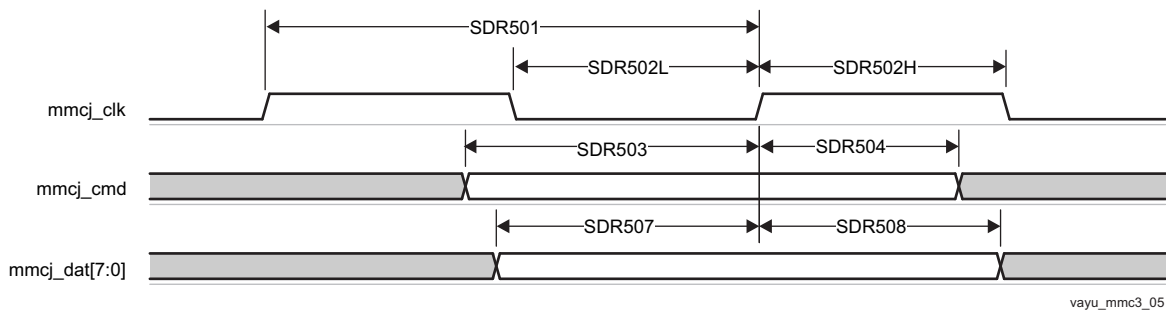

Figure 5-106. MMC/SD/SDIOj in - High Speed SDR50 - Receiver Mode

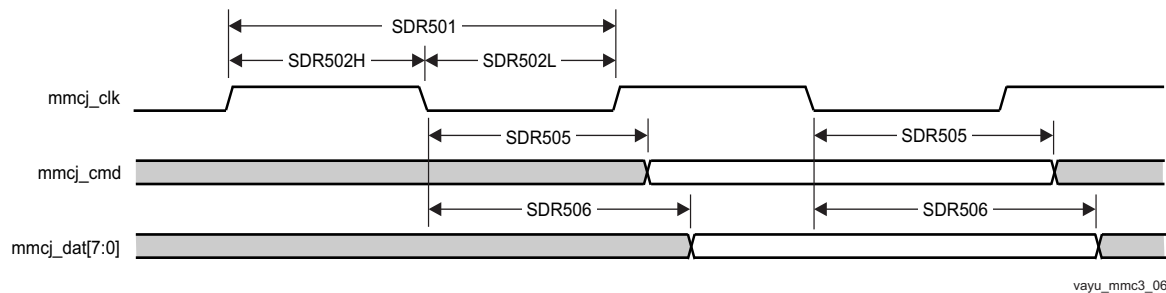

Figure 5-107. MMC/SD/SDIOj in - High Speed SDR50 - Transmitter Mode

### NOTE

To configure the desired manual IO timing mode the user must follow the steps described in *Manual IO Timing Modes* section in the device TRM.

The associated registers to configure are listed in the **CFG REGISTER** column. For more information, see *Control Module* chapter in the device TRM.

Manual IO Timings Modes must be used to ensure some IO timings for MMC3. See [Table 5-33, Modes Summary](#) for a list of IO timings requiring the use of Manual IO Timings Modes. See [Table 5-164, Manual Functions Mapping for MMC3](#) for a definition of the Manual modes.

[Table 5-164](#) lists the A\_DELAY and G\_DELAY values needed to calculate the correct values to be set in the CFG\_x registers.

**Table 5-164. Manual Functions Mapping for MMC3**

BALL	BALL NAME	MMC3_MANUAL1		MMC3_MANUAL2		CFG REGISTER	MUXMODE
		A_DELAY (ps)	G_DELAY (ps)	A_DELAY (ps)	G_DELAY (ps)		0
AD4	mmc3_clk	0	386	852	0	CFG_MMC3_CLK_IN	mmc3_clk
AD4	mmc3_clk	605	0	94	0	CFG_MMC3_CLK_OUT	mmc3_clk
AC4	mmc3_cmd	0	0	122	0	CFG_MMC3_CMD_IN	mmc3_cmd
AC4	mmc3_cmd	0	0	0	0	CFG_MMC3_CMD_OEN	mmc3_cmd
AC4	mmc3_cmd	0	0	0	0	CFG_MMC3_CMD_OUT	mmc3_cmd
AC7	mmc3_dat0	171	0	91	0	CFG_MMC3_DAT0_IN	mmc3_dat0
AC7	mmc3_dat0	0	0	0	0	CFG_MMC3_DAT0_OEN	mmc3_dat0
AC7	mmc3_dat0	0	0	0	0	CFG_MMC3_DAT0_OUT	mmc3_dat0
AC6	mmc3_dat1	221	0	57	0	CFG_MMC3_DAT1_IN	mmc3_dat1
AC6	mmc3_dat1	0	0	0	0	CFG_MMC3_DAT1_OEN	mmc3_dat1
AC6	mmc3_dat1	0	0	0	0	CFG_MMC3_DAT1_OUT	mmc3_dat1
AC9	mmc3_dat2	0	0	0	0	CFG_MMC3_DAT2_IN	mmc3_dat2
AC9	mmc3_dat2	0	0	0	0	CFG_MMC3_DAT2_OEN	mmc3_dat2
AC9	mmc3_dat2	0	0	0	0	CFG_MMC3_DAT2_OUT	mmc3_dat2
AC3	mmc3_dat3	474	0	375	0	CFG_MMC3_DAT3_IN	mmc3_dat3
AC3	mmc3_dat3	0	0	0	0	CFG_MMC3_DAT3_OEN	mmc3_dat3
AC3	mmc3_dat3	0	0	0	0	CFG_MMC3_DAT3_OUT	mmc3_dat3
AC8	mmc3_dat4	792	0	213	0	CFG_MMC3_DAT4_IN	mmc3_dat4
AC8	mmc3_dat4	0	0	0	0	CFG_MMC3_DAT4_OEN	mmc3_dat4
AC8	mmc3_dat4	0	0	0	0	CFG_MMC3_DAT4_OUT	mmc3_dat4
AD6	mmc3_dat5	782	0	355	0	CFG_MMC3_DAT5_IN	mmc3_dat5
AD6	mmc3_dat5	0	0	0	0	CFG_MMC3_DAT5_OEN	mmc3_dat5
AD6	mmc3_dat5	0	0	0	0	CFG_MMC3_DAT5_OUT	mmc3_dat5
AB8	mmc3_dat6	942	0	437	0	CFG_MMC3_DAT6_IN	mmc3_dat6
AB8	mmc3_dat6	0	0	0	0	CFG_MMC3_DAT6_OEN	mmc3_dat6
AB8	mmc3_dat6	0	0	0	0	CFG_MMC3_DAT6_OUT	mmc3_dat6
AB5	mmc3_dat7	636	0	224	0	CFG_MMC3_DAT7_IN	mmc3_dat7
AB5	mmc3_dat7	0	0	0	0	CFG_MMC3_DAT7_OEN	mmc3_dat7
AB5	mmc3_dat7	0	0	0	0	CFG_MMC3_DAT7_OUT	mmc3_dat7

Manual IO Timings Modes must be used to ensure some IO timings for MMC4. See [Table 5-33, Modes Summary](#) for a list of IO timings requiring the use of Manual IO Timings Modes. See [Table 5-165, Manual Functions Mapping for MMC4](#) for a definition of the Manual modes.

[Table 5-165](#) lists the A\_DELAY and G\_DELAY values needed to calculate the correct values to be set in the CFG\_x registers.

**Table 5-165. Manual Functions Mapping for MMC4**

BALL	BALL NAME	MMC4_MANUAL1		MMC4_DS_MANUAL1		CFG REGISTER	MUXMODE
		A_DELAY (ps)	G_DELAY (ps)	A_DELAY (ps)	G_DELAY (ps)		3
E25	uart1_ctsn	0	0	0	0	CFG_UART1_CTSN_IN	mmc4_clk
E25	uart1_ctsn	1147	0	0	0	CFG_UART1_CTSN_OUT	mmc4_clk
C27	uart1_rtsn	1834	0	307	0	CFG_UART1_RTSN_IN	mmc4_cmd
C27	uart1_rtsn	0	0	0	0	CFG_UART1_RTSN_OEN	mmc4_cmd
C27	uart1_rtsn	0	0	0	0	CFG_UART1_RTSN_OUT	mmc4_cmd
D27	uart2_ctsn	2165	0	785	0	CFG_UART2_CTSN_IN	mmc4_dat2
D27	uart2_ctsn	0	0	0	0	CFG_UART2_CTSN_OEN	mmc4_dat2
D27	uart2_ctsn	0	0	0	0	CFG_UART2_CTSN_OUT	mmc4_dat2
C28	uart2_rtsn	1929	64	613	0	CFG_UART2_RTSN_IN	mmc4_dat3
C28	uart2_rtsn	0	0	0	0	CFG_UART2_RTSN_OEN	mmc4_dat3
C28	uart2_rtsn	0	0	0	0	CFG_UART2_RTSN_OUT	mmc4_dat3
D28	uart2_rxd	1935	128	683	0	CFG_UART2_RXD_IN	mmc4_dat0
D28	uart2_rxd	0	0	0	0	CFG_UART2_RXD_OEN	mmc4_dat0
D28	uart2_rxd	0	0	0	0	CFG_UART2_RXD_OUT	mmc4_dat0
D26	uart2_txd	2172	44	835	0	CFG_UART2_TXD_IN	mmc4_dat1
D26	uart2_txd	0	0	0	0	CFG_UART2_TXD_OEN	mmc4_dat1
D26	uart2_txd	0	0	0	0	CFG_UART2_TXD_OUT	mmc4_dat1

### 5.10.6.20 PRU-ICSS

The device Programmable Real-Time Unit and Industrial Communication Subsystem (PRU-ICSS) consists of dual 32-bit Load / Store RISC CPU cores - Programmable Real-Time Units (PRU0 and PRU1), shared, data, and instruction memories, internal peripheral modules, and an interrupt controller (PRU-ICSS\_INTC). The programmable nature of the PRUs, along with their access to pins, events and all SoC resources, provides flexibility in implementing fast real-time responses, specialized data handling operations, customer peripheral interfaces, and in off-loading tasks from the other processor cores of the system-on-chip (SoC).

The each PRU-ICSS includes the following main features:

- 21x Enhanced GPIs (EGPIs) and 21x Enhanced GPOs (EGPOs) with asynchronous capture and serial support per each PRU CPU core
- One Ethernet MII\_RT module (PRU-ICSS\_MII\_RT) with two MII ports and configurable connections to PRUs
- 1 MDIO Port (PRU-ICSS\_MII\_MDIO)
- One Industrial Ethernet Peripheral (IEP) to manage/generate Industrial Ethernet functions
- 1 x 16550-compatible UART with a dedicated 192 MHz clock to support 12 Mbps Profibus
- 1 Industrial Ethernet timer with 7/9 capture and 8 compare events
- 1 Enhanced Capture Module (ECAP)
- 1 Interrupt Controller (PRU-ICSS\_INTC)
- A flexible power management support
- Integrated switched central resource with programmable priority



- Parity control supported by all memories

**CAUTION**

The IO timings provided in this section are only valid if signals within a single IOSET are used. The IOSETs are defined in the [Table 5-188](#) and [Table 5-189](#).

**NOTE**

For more information, see *PRU-ICSS* section in the Device TRM.

**NOTE**

To configure the desired virtual mode the user must set MODESELECT bit and DELAYMODE bit field for each corresponding pad control register.

The pad control registers are presented in [Table 4-33](#) and described in chapter Control Module in the device TRM.

**5.10.6.20.1 Programmable Real-Time Unit (PRU-ICSS PRU)**

**5.10.6.20.1.1 PRU-ICSS PRU Direct Input/Output Mode Electrical Data and Timing**

**Table 5-166. PRU-ICSS PRU Timing Requirements - Direct Input Mode**

NO.	PARAMETER	DESCRIPTION	MIN	MAX	UNIT
PRDI1	$t_w(\text{GPI})$	Pulse width, GPI	2P <sup>(1)</sup>		ns
PRDI2	$t_{sk}(\text{GPI})$	Skew between GPI[20:0] signals		4.5	ns

(1) PRUSS\_GICLK clock period

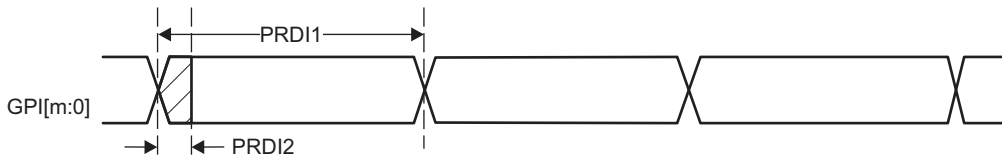

SPRS91x\_TIMING\_PRU\_01

**Figure 5-108. PRU-ICSS PRU Direct Input Timing**

(1) m in GPI[m:0] = 20

**Table 5-167. PRU-ICSS PRU Switching Requirements – Direct Output Mode**

NO.	PARAMETER	DESCRIPTION	MIN	MAX	UNIT
PRDO1	$t_w(\text{GPO})$	Pulse width, GPO	2P <sup>(1)</sup>		ns
PRDO2	$t_{sk}(\text{GPO})$	Skew between GPO[20:0] signals		4.5	ns

(1) PRUSS\_GICLK clock period

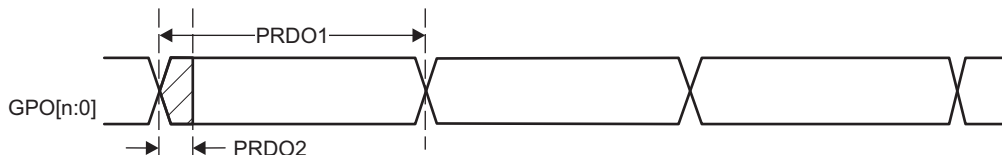

SPRS91x\_TIMING\_PRU\_02

**Figure 5-109. PRU-ICSS PRU Direct Output Timing**

(1) n in GPO[n:0] = 20

5.10.6.20.1.2 PRU-ICSS PRU Parallel Capture Mode Electrical Data and Timing

Table 5-168. PRU-ICSS PRU Timing Requirements - Parallel Capture Mode

NO.	PARAMETER	DESCRIPTION	MIN	MAX	UNIT
PRPC1	$t_w(\text{CLOCKIN})$	Cyle time, CLOCKIN	20		ns
PRPC2	$t_w(\text{CLOCKIN\_L})$	Pulse duration, CLOCKIN low	9	11	ns
PRPC3	$t_w(\text{CLOCKIN\_H})$	Pulse duration, CLOCKIN high	9	11	ns
PRPC4	$t_{su}(\text{DATAIN-CLOCKIN})$	Setup time, DATAIN valid before CLOCKIN	4.5		ns
PRPC5	$t_h(\text{CLOCKIN-DATAIN})$	Hold time, DATAIN valid after CLOCKIN	0		ns

(1) PRUSS\_GICLK clock period

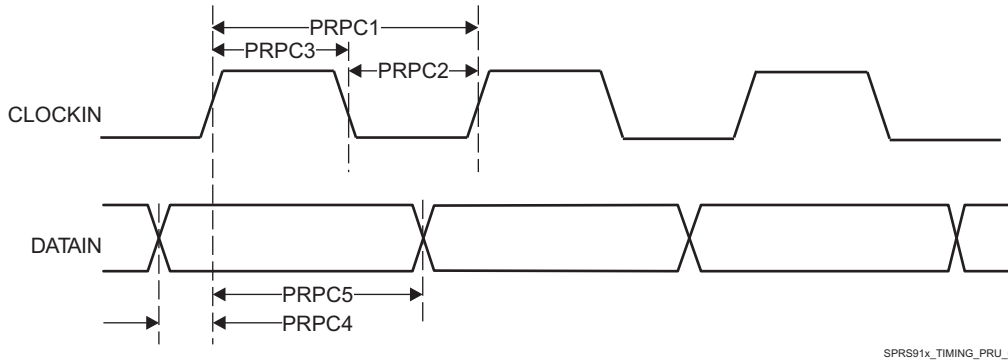

SPRS91x\_TIMING\_PRU\_03

Figure 5-110. PRU-ICSS PRU Parallel Capture Timing - Rising Edge Mode

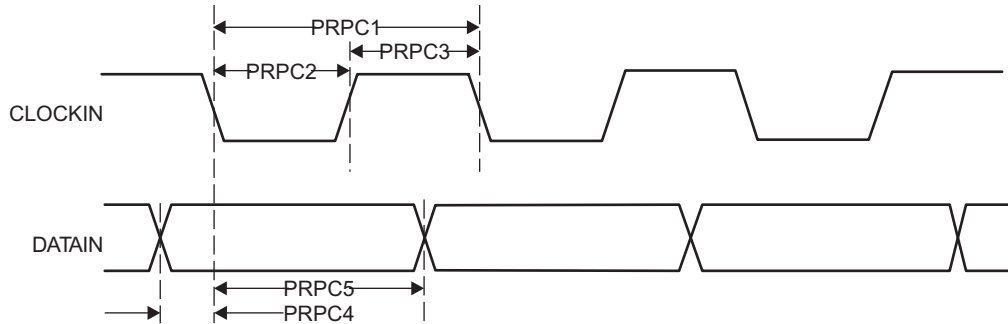

SPRS91x\_TIMING\_PRU\_04

Figure 5-111. PRU-ICSS PRU Parallel Capture Timing - Falling Edge Mode

5.10.6.20.1.3 PRU-ICSS PRU Shift Mode Electrical Data and Timing

Table 5-169. PRU-ICSS PRU Timing Requirements – Shift In Mode

NO.	PARAMETER	DESCRIPTION	MIN	MAX	UNIT
PRSI1	$t_c(\text{DATAIN})$	Cycle time, DATAIN	10.00		ns
PRSI2	$t_w(\text{DATAIN})$	Pulse width, DATAIN	0.45P <sup>(1)</sup>	0.55P <sup>(1)</sup>	ns

(1) P = 10.00 ns

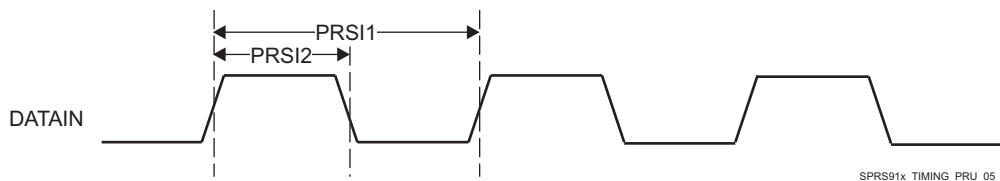

SPRS91x\_TIMING\_PRU\_05

Figure 5-112. PRU-ICSS PRU Shift In Timing

**Table 5-170. PRU-ICSS PRU Switching Requirements - Shift Out Mode**

NO.	PARAMETER	DESCRIPTION	MIN	MAX	UNIT
PRSO1	$t_{c(CLOCKOUT)}$	Cycle time, CLOCKOUT	10.00		ns
PRSO2	$t_{w(CLOCKOUT)}$	Pulse width, CLOCKOUT	0.45P <sup>(1)</sup>	0.55P <sup>(1)</sup>	ns
PRSO3	$t_{d(CLOCKOUT-DATAOUT)}$	Delay time, CLOCKOUT to DATAOUT Valid	-3.00	3.60	ns

(1) P = 10.00 ns

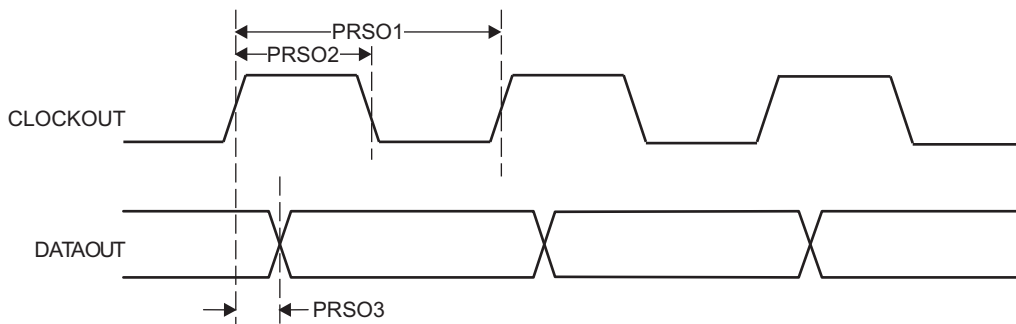

SPRS91x\_TIMING\_PRU\_06

**Figure 5-113. PRU-ICSS PRU Shift Out Timing**

**5.10.6.20.1.4 PRU-ICSS PRU Sigma Delta and EnDAT<sup>®</sup> Modes**

**Table 5-171. PRU-ICSS PRU Timing Requirements - Sigma Delta Mode**

NO.	PARAMETER	DESCRIPTION	MIN	MAX	UNIT
1	$t_w(SDx\_CLK)$	Pulse width, SDx_CLK	20		ns
2	$t_{su}(SDx\_D-SDx\_CLK)$	Setup time, SDx_D valid before SDx_CLK active edge	10		ns
3	$t_h(SDx\_CLK-SDx\_D)$	Hold time, SDx_D valid before SDx_CLK active edge	5		ns

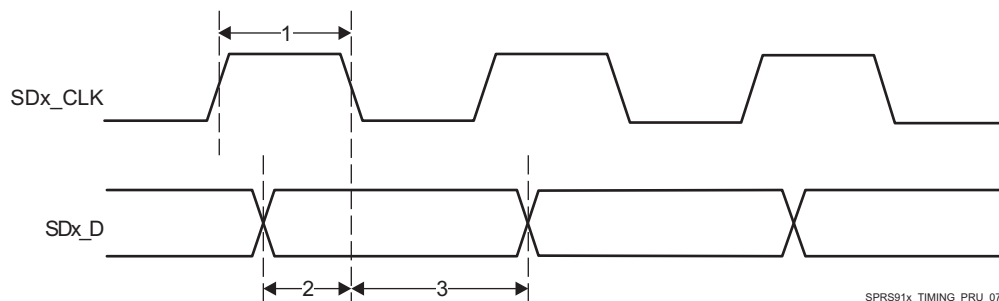

SPRS91x\_TIMING\_PRU\_07

**Figure 5-114. PRU-ICSS PRU SD\_CLK Falling Active Edge**

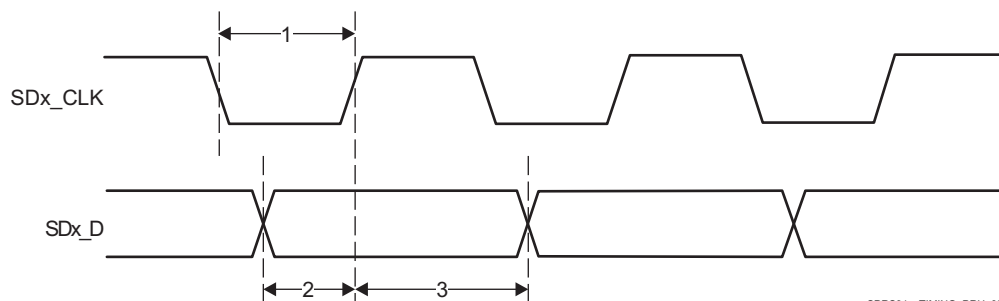

SPRS91x\_TIMING\_PRU\_08

**Figure 5-115. PRU-ICSS PRU SD\_CLK Rising Active Edge**

**Table 5-172. PRU-ICSS PRU Timing Requirements - EnDAT Mode**

NO.	PARAMETER	DESCRIPTION	MIN	MAX	UNIT
1	tw(ENDATx_IN)	Pulse width, ENDATx_IN	40		ns

**Table 5-173. PRU-ICSS PRU Switching Requirements - EnDAT Mode**

NO.	PARAMETER	DESCRIPTION	MIN	MAX	UNIT
2	tw(ENDATx_CLK)	Pulse width, ENDATx_CLK	20		ns
3	td(ENDATx_OUT- ENDATx_CLK)	Delay time, ENDATx_CLK fall to ENDATx_OUT	-10	10	ns
4	td(ENDATx_OUT_EN- ENDATx_CLK)	Delay time, ENDATx_CLK Fall to ENDATx_OUT_EN	-10	10	ns

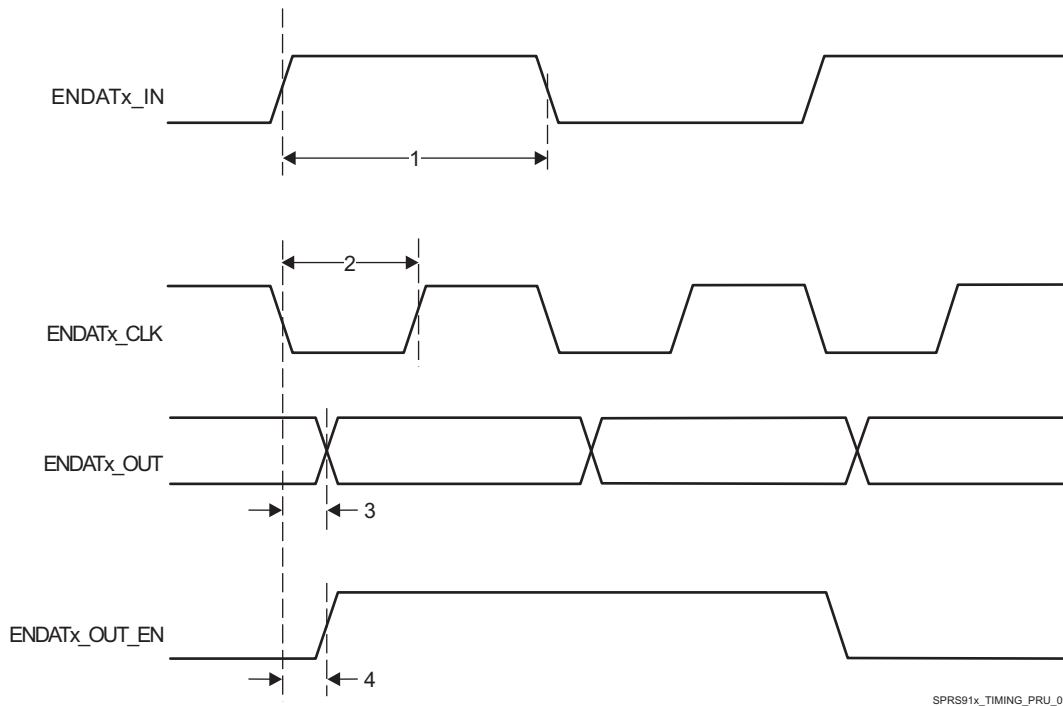

SPRS91x\_TIMING\_PRU\_09

**Figure 5-116. PRU-ICSS PRU EnDAT Timing**

**5.10.6.20.2 PRU-ICSS EtherCAT (PRU-ICSS ECAT)**

**5.10.6.20.2.1 PRU-ICSS ECAT Electrical Data and Timing**

**Table 5-174. PRU-ICSS ECAT Timing Requirements – Input Validated With LATCH\_IN**

NO.	PARAMETER	DESCRIPTION	MIN	MAX	UNIT
EDIOL1	t <sub>w</sub> (EDIO_LATCH_IN)	Pulse width, EDIO_LATCH_IN	100.00		ns
EDIOL2	t <sub>su</sub> (EDIO_DATA_IN- EDIO_LATCH_IN)	Setup time, EDIO_DATA_IN valid before EDIO_LATCH_IN active edge	20.00		ns
EDIOL3	t <sub>h</sub> (EDIO_LATCH_IN- EDIO_DATA_IN)	Hold time, EDIO_DATA_IN valid after EDIO_LATCH_IN active edge	20.00		ns

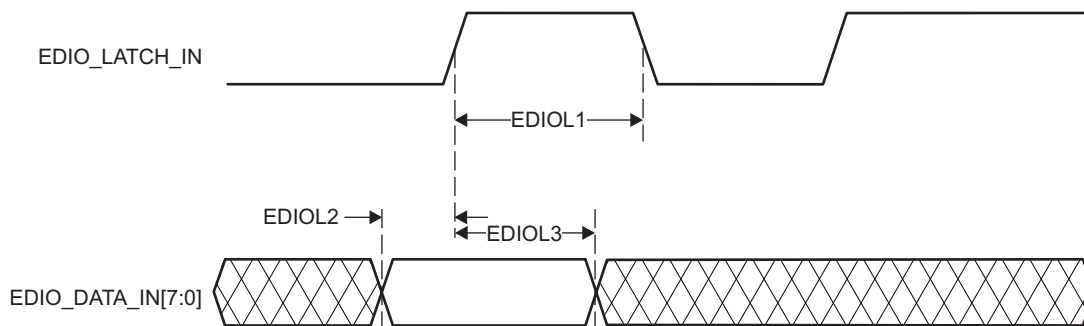

SPRS91x\_TIMING\_PRU\_ECATCH\_01

Figure 5-117. PRU-ICSS ECAT Input Validated with LATCH\_IN Timing

Table 5-175. PRU-ICSS ECAT Timing Requirements – Input Validated With SYNCx

NO.	PARAMETER	DESCRIPTION	MIN	MAX	UNIT
EDCS1	$t_w(\text{EDC\_SYNCx\_OUT})$	Pulse width, EDC_SYNCx_OUT	100.00		ns
EDCS2	$t_{su}(\text{EDIO\_DATA\_IN-EDC\_SYNCx\_OUT})$	Setup time, EDIO_DATA_IN valid before EDC_SYNCx_OUT active edge	20.00		ns
EDCS3	$t_h(\text{EDC\_SYNCx\_OUT-EDIO\_DATA\_IN})$	Hold time, EDIO_DATA_IN valid after EDC_SYNCx_OUT active edge	20.00		ns

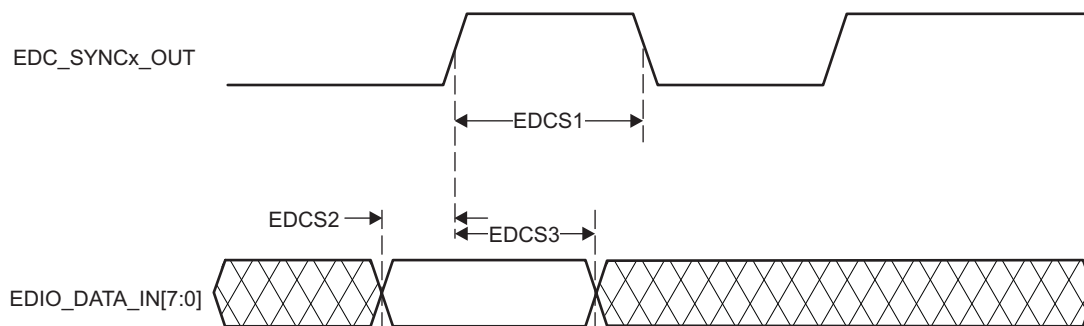

SPRS91x\_TIMING\_PRU\_ECATCH\_02

Figure 5-118. PRU-ICSS ECAT Input Validated With SYNCx Timing

Table 5-176. PRU-ICSS ECAT Timing Requirements – Input Validated With Start of Frame (SOF)

NO.	PARAMETER	DESCRIPTION	MIN	MAX	UNIT
EDIOS1	$t_w(\text{EDIO\_SOF})$	Pulse duration, EDIO_SOF	4P <sup>(1)</sup>	5P <sup>(1)</sup>	ns
EDIOS2	$t_{su}(\text{EDIO\_DATA\_IN-EDIO\_SOF})$	Setup time, EDIO_DATA_IN valid before EDIO_SOF active edge	20.00		ns
EDIOS3	$t_h(\text{EDIO\_SOF-EDIO\_DATA\_IN})$	Hold time, EDIO_DATA_IN valid after EDIO_SOF active edge	20.00		ns

(1) PRUSS\_IEP\_CLK clock period

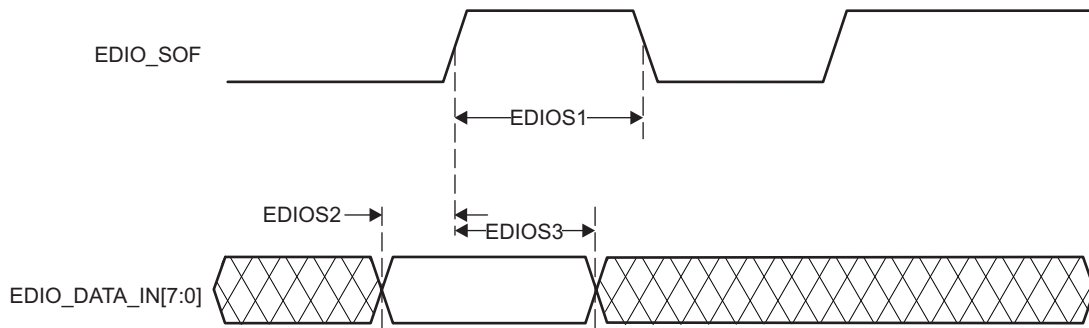

SPRS91x\_TIMING\_PRU\_ECAC\_03

Figure 5-119. PRU-ICSS ECAT Input Validated With SOF

Table 5-177. PRU-ICSS ECAT Timing Requirements - LATCHx\_IN

NO.	PARAMETER	DESCRIPTION	MIN	MAX	UNIT
EDCL1	$t_w(\text{EDC\_LATCHx\_IN})$	Pulse duration, EDC_LATCHx_IN	3P <sup>(1)</sup>		ns

(1) PRUSS\_IEP\_CLK clock period



SPRS91x\_TIMING\_PRU\_ECAC\_04

Figure 5-120. PRU-ICSS ECAT LATCHx\_IN Timing

Table 5-178. PRU-ICSS ECAT Switching Requirements - Digital IOs

NO.	PARAMETER	DESCRIPTION	MIN	MAX	UNIT
EDIOD1	$t_{sk}(\text{EDIO\_DATA\_OUT})$	EDIO_DATA_OUT skew		8	ns

### 5.10.6.20.3 PRU-ICSS MII\_RT and Switch

#### 5.10.6.20.3.1 PRU-ICSS MDIO Electrical Data and Timing

Table 5-179. PRU-ICSS MDIO Timing Requirements – MDIO\_DATA

NO.	PARAMETER	DESCRIPTION	MIN	MAX	UNIT
PRMDI1	$t_{su}(\text{MDIO-MDC})$	Setup time, MDIO valid before MDC high	90		ns
PRMDI2	$t_h(\text{MDIO-MDC})$	Hold time, MDIO valid from MDC high	0		ns

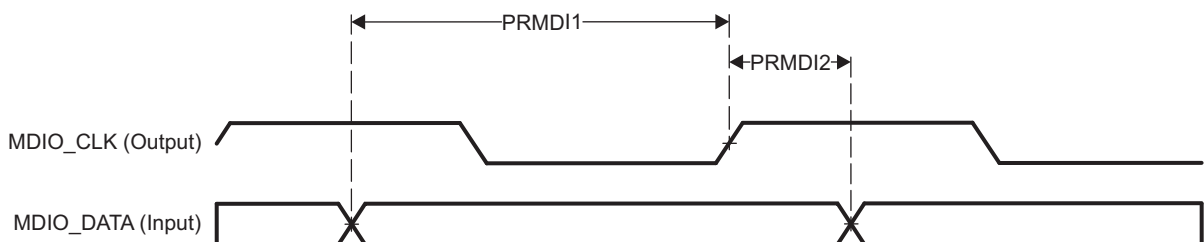

SPRS91x\_TIMING\_PRU\_MII\_RT\_01

Figure 5-121. PRU-ICSS MDIO\_DATA Timing - Input Mode

**Table 5-180. PRU-ICSS MDIO Switching Characteristics - MDIO\_CLK**

NO.	PARAMETER	DESCRIPTION	MIN	MAX	UNIT
PRMC1	$t_c(\text{MDC})$	Cycle time, MDC	400		ns
PRMC2	$t_w(\text{MDCH})$	Pulse duration, MDC high	160		ns
PRMC3	$t_w(\text{MDCL})$	Pulse duration, MDC low	160		ns
PRMC4	$t_t(\text{MDC})$	Transition time, MDC		5	ns

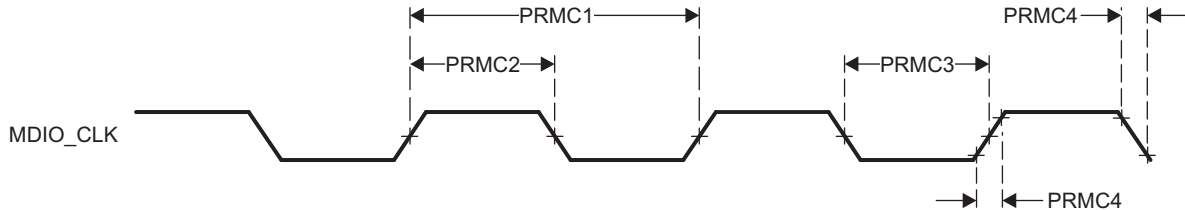

SPRS91x\_TIMING\_PRU\_MII\_RT\_02

**Figure 5-122. PRU-ICSS MDIO\_CLK Timing**

**Table 5-181. PRU-ICSS MDIO Switching Characteristics – MDIO\_DATA**

NO.	PARAMETER	DESCRIPTION	MIN	MAX	UNIT
PRMDO1	$t_d(\text{MDC-MDIO})$	Delay time, MDC high to MDIO valid	0	390	ns

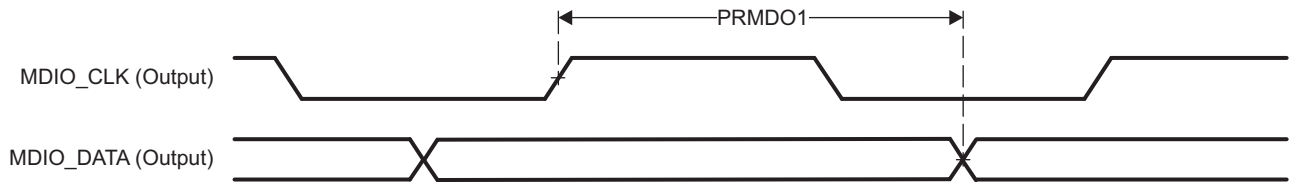

SPRS91x\_TIMING\_PRU\_MII\_RT\_03

**Figure 5-123. PRU-ICSS MDIO\_DATA Timing – Output Mode**

**5.10.6.20.3.2 PRU-ICSS MII\_RT Electrical Data and Timing**

**NOTE**

In order to ensure the MII\_RT IO timing values published in the device Data Manual, the PRUSS\_GICLK clock must be configured for 200 MHz (default value) and the TX\_CLK\_DELAY bit field in the PRUSS\_MII\_RT\_TXCFG0/1 register must be set to 6h (non-default value).

**Table 5-182. PRU-ICSS MII\_RT Timing Requirements – MII[x]\_RXCLK**

NO.	PARAMETER	DESCRIPTION	SPEED	MIN	MAX	UNIT
PMIR1	$t_c(\text{RX\_CLK})$	Cycle time, RX_CLK	10 Mbps	399.96	400.04	ns
			100 Mbps	39.996	40.004	ns
PMIR2	$t_w(\text{RX\_CLKH})$	Pulse duration, RX_CLK high	10 Mbps	140	260	ns
			100 Mbps	14	26	ns
PMIR3	$t_w(\text{RX\_CLKL})$	Pulse duration, RX_CLK low	10 Mbps	140	260	ns
			100 Mbps	14	26	ns

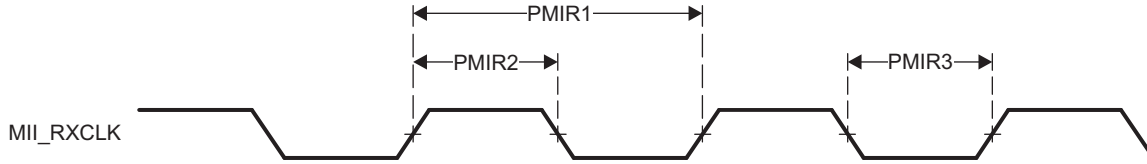

SPRS91x\_TIMING\_PRU\_MII\_RT\_04

Figure 5-124. PRU-ICSS MII[x]\_RXCLK Timing

Table 5-183. PRU-ICSS MII\_RT Timing Requirements - MII[x]\_TXCLK

NO.	PARAMETER	DESCRIPTION	SPEED	MIN	MAX	UNIT
PMIT1	$t_{c(TX\_CLK)}$	Cycle time, TX_CLK	10 Mbps	399.96	400.04	ns
			100 Mbps	39.996	40.004	ns
PMIT2	$t_{w(TX\_CLKH)}$	Pulse duration, TX_CLK high	10 Mbps	140	260	ns
			100 Mbps	14	26	ns
PMIT3	$t_{w(TX\_CLKL)}$	Pulse duration, TX_CLK low	10 Mbps	140	260	ns
			100 Mbps	14	26	ns
PMIT4	$t_{t(TX\_CLK)}$	Transition time, TX_CLK	10 Mbps		3	ns
			100 Mbps		3	ns

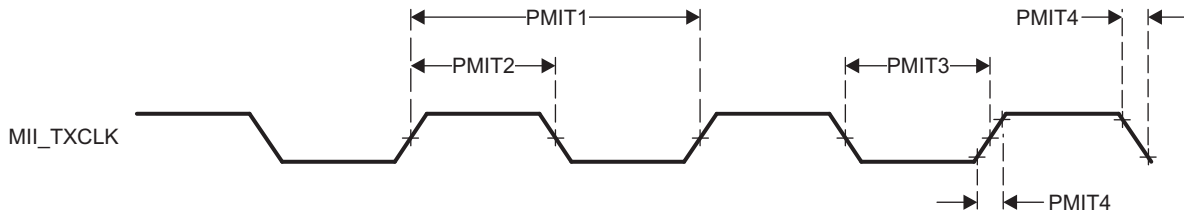

SPRS91x\_TIMING\_PRU\_MII\_RT\_05

Figure 5-125. PRU-ICSS MII[x]\_TXCLK Timing

Table 5-184. PRU-ICSS MII\_RT Timing Requirements - MII\_RXD[3:0], MII\_RXDV, and MII\_RXER

NO.	PARAMETER	DESCRIPTION	SPEED	MIN	MAX	UNIT	
PMIR4	$t_{su(RXD-RX\_CLK)}$	Setup time, RXD[3:0] valid before RX_CLK	10 Mbps	8		ns	
	$t_{su(RX\_DV-RX\_CLK)}$	Setup time, RX_DV valid before RX_CLK					
	$t_{su(RX\_ER-RX\_CLK)}$	Setup time, RX_ER valid before RX_CLK					
	PMIR5	$t_{su(RXD-RX\_CLK)}$	Setup time, RXD[3:0] valid before RX_CLK	100 Mbps	8		ns
		$t_{su(RX\_DV-RX\_CLK)}$	Setup time, RX_DV valid before RX_CLK				
		$t_{su(RX\_ER-RX\_CLK)}$	Setup time, RX_ER valid before RX_CLK				
PMIR5	$t_{h(RX\_CLK-RXD)}$	Hold time RXD[3:0] valid after RX_CLK	10 Mbps	8		ns	
	$t_{h(RX\_CLK-RX\_DV)}$	Hold time RX_DV valid after RX_CLK					
	$t_{h(RX\_CLK-RX\_ER)}$	Hold time RX_ER valid after RX_CLK					
	PMIR5	$t_{h(RX\_CLK-RXD)}$	Hold time RXD[3:0] valid after RX_CLK	100 Mbps	8		ns
		$t_{h(RX\_CLK-RX\_DV)}$	Hold time RX_DV valid after RX_CLK				
		$t_{h(RX\_CLK-RX\_ER)}$	Hold time RX_ER valid after RX_CLK				



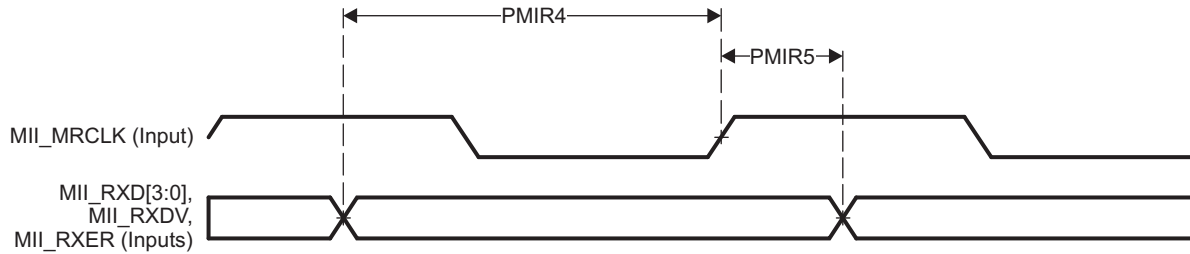

SPRS91x\_TIMING\_PRU\_MII\_RT\_06

Figure 5-126. PRU-ICSS MII\_RXD[3:0], MII\_RXDV, and MII\_RXER Timing

Table 5-185. PRU-ICSS MII\_RT Switching Characteristics - MII\_TXD[3:0] and MII\_TXEN

NO.	PARAMETER	DESCRIPTION	SPEED	MIN	MAX	UNIT
PMIT5	$t_d(TX\_CLK-TXD)$	Delay time, TX_CLK high to TXD[3:0] valid	10 Mbps	0	35	ns
	$t_d(TX\_CLK-TX\_EN)$	Delay time, TX_CLK to TX_EN valid				
	$t_d(TX\_CLK-TXD)$	Delay time, TX_CLK high to TXD[3:0] valid	100 Mbps	0	25	ns
	$t_d(TX\_CLK-TX\_EN)$	Delay time, TX_CLK to TX_EN valid				

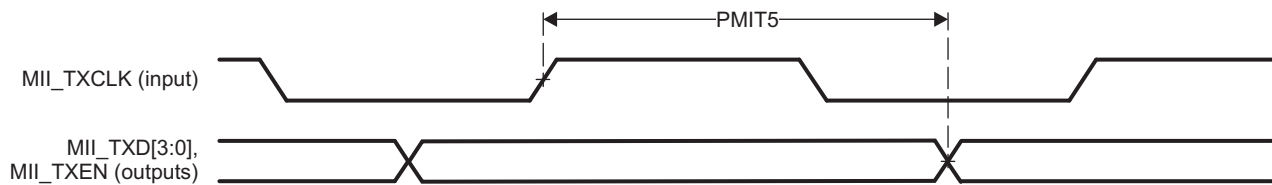

SPRS91x\_TIMING\_PRU\_MII\_RT\_07

Figure 5-127. PRU-ICSS MII\_TXD[3:0], MII\_TXEN Timing

5.10.6.20.4 PRU-ICSS Universal Asynchronous Receiver Transmitter (PRU-ICSS UART)

Table 5-186. Timing Requirements for PRU-ICSS UART Receive

NO.	PARAMETER	DESCRIPTION	MIN	MAX	UNIT
PRUR1	$t_w(RX)$	Pulse duration, receive start, stop, data bit	0.96U <sup>(1)</sup>	1.05U <sup>(1)</sup>	ns

(1) U = UART baud time = 1 / programmed baud rate.

Table 5-187. Switching Characteristics Over Recommended Operating Conditions for PRU-ICSS UART Transmit

NO.	PARAMETER	DESCRIPTION	MIN	MAX	UNIT
PRUT1	$f_{baud(baud)}$	Maximum programmable baud rate	0	12	MHz
PRUT2	$t_w(TX)$	Pulse duration, transmit start, stop, data bit	U <sup>(1)</sup> - 2	U <sup>(1)</sup> + 2	ns

(1) U = UART baud time = 1 / programmed baud rate.

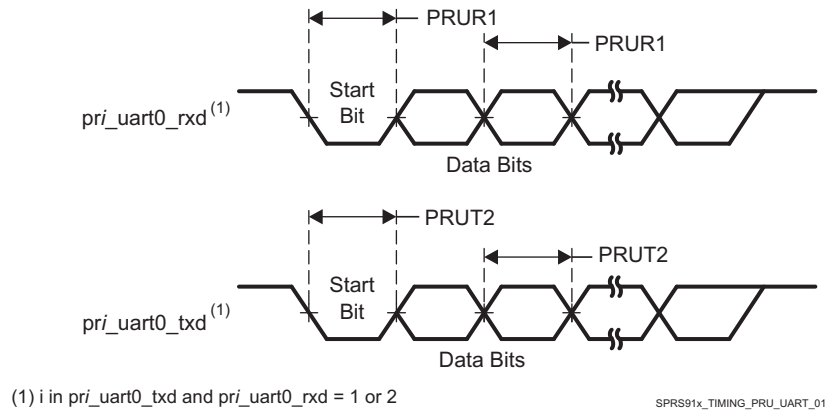

Figure 5-128. PRU-ICSS UART Timing

5.10.6.20.5 PRU-ICSS IOSETs

In Table 5-188 and Table 5-189 are presented the specific groupings of signals (IOSET) for use with PRU-ICSS1 and PRU-ICSS2.

Table 5-188. PRU-ICSS1 IOSETs

SIGNALS	IOSET1		IOSET2		IOSET3 <sup>(1) (2)</sup>		IOSET4 <sup>(1) (2)</sup>	
	BALL	MUX	BALL	MUX	BALL	MUX	BALL	MUX
<b>PRU-ICSS1</b>								
pr1_pru1_gpi20	A4	12						
pr1_pru1_gpi19	B5	12						
pr1_pru1_gpi18	B4	12						
pr1_pru1_gpi17	B3	12						
pr1_pru1_gpi16	A3	12						
pr1_pru1_gpi15	C5	12						
pr1_pru1_gpi14	D6	12						
pr1_pru1_gpi13	B2	12						
pr1_pru1_gpi12	C4	12						
pr1_pru1_gpi11	C3	12						
pr1_pru1_gpi10	C2	12						
pr1_pru1_gpo20	A4	13						
pr1_pru1_gpo19	B5	13						
pr1_pru1_gpo18	B4	13						
pr1_pru1_gpo17	B3	13						
pr1_pru1_gpo16	A3	13						
pr1_pru1_gpo15	C5	13						
pr1_pru1_gpo14	D6	13						
pr1_pru1_gpo13	B2	13						
pr1_pru1_gpo12	C4	13						
pr1_pru1_gpo11	C3	13						
pr1_pru1_gpo10	C2	13						
pr1_pru1_gpi9	D5	12						
pr1_pru1_gpi8	F6	12						
pr1_pru1_gpi7	D3	12						

**Table 5-188. PRU-ICSS1 IOSETs (continued)**

SIGNALS	IOSET1		IOSET2		IOSET3 <sup>(1) (2)</sup>		IOSET4 <sup>(1) (2)</sup>	
	BALL	MUX	BALL	MUX	BALL	MUX	BALL	MUX
pr1_pru1_gpi6	E6	12						
pr1_pru1_gpi5	F5	12						
pr1_pru1_gpi4	E4	12						
pr1_pru1_gpi3	C1	12						
pr1_pru1_gpi2	F4	12						
pr1_pru1_gpi1	D2	12						
pr1_pru1_gpi0	E2	12						
pr1_pru1_gpo9	D5	13						
pr1_pru1_gpo8	F6	13						
pr1_pru1_gpo7	D3	13						
pr1_pru1_gpo6	E6	13						
pr1_pru1_gpo5	F5	13						
pr1_pru1_gpo4	E4	13						
pr1_pru1_gpo3	C1	13						
pr1_pru1_gpo2	F4	13						
pr1_pru1_gpo1	D2	13						
pr1_pru1_gpo0	E2	13						
pr1_pru0_gpi20	AD3	12						
pr1_pru0_gpi19	AD2	12						
pr1_pru0_gpi18	AE6	12						
pr1_pru0_gpi17	AE2	12						
pr1_pru0_gpi16	AE1	12						
pr1_pru0_gpi15	AE5	12						
pr1_pru0_gpi14	AE3	12						
pr1_pru0_gpi13	AF1	12						
pr1_pru0_gpi12	AF4	12						
pr1_pru0_gpi11	AF3	12						
pr1_pru0_gpi10	AF6	12						
pr1_pru0_gpo20	AD3	13						
pr1_pru0_gpo19	AD2	13						
pr1_pru0_gpo18	AE6	13						
pr1_pru0_gpo17	AE2	13						
pr1_pru0_gpo16	AE1	13						
pr1_pru0_gpo15	AE5	13						
pr1_pru0_gpo14	AE3	13						
pr1_pru0_gpo13	AF1	13						
pr1_pru0_gpo12	AF4	13						
pr1_pru0_gpo11	AF3	13						
pr1_pru0_gpo10	AF6	13						
pr1_pru0_gpi9	AF2	12						
pr1_pru0_gpi8	AG5	12						
pr1_pru0_gpi7	AG3	12						
pr1_pru0_gpi6	AG2	12						
pr1_pru0_gpi5	AG4	12						
pr1_pru0_gpi4	AH4	12						
pr1_pru0_gpi3	AG6	12						

Table 5-188. PRU-ICSS1 IOSETs (continued)

SIGNALS	IOSET1		IOSET2		IOSET3 <sup>(1) (2)</sup>		IOSET4 <sup>(1) (2)</sup>	
	BALL	MUX	BALL	MUX	BALL	MUX	BALL	MUX
pr1_pru0_gpi2	AH5	12						
pr1_pru0_gpi1	AH3	12						
pr1_pru0_gpi0	AH6	12						
pr1_pru0_gpo9	AF2	13						
pr1_pru0_gpo8	AG5	13						
pr1_pru0_gpo7	AG3	13						
pr1_pru0_gpo6	AG2	13						
pr1_pru0_gpo5	AG4	13						
pr1_pru0_gpo4	AH4	13						
pr1_pru0_gpo3	AG6	13						
pr1_pru0_gpo2	AH5	13						
pr1_pru0_gpo1	AH3	13						
pr1_pru0_gpo0	AH6	13						
pr1_edio_data_out7	AD3	11	D1	13				
pr1_edio_data_out6	AD2	11	F3	13				
pr1_edio_data_out5	AE6	11	F2	13				
pr1_edio_data_out4	AE2	11	G6	13				
pr1_edio_data_out3	AE1	11	G1	13				
pr1_edio_data_out2	AE5	11	H7	13				
pr1_edio_data_out1	AE3	11	G2	13				
pr1_edio_data_out0	AF1	11	E1	13				
pr1_edio_data_in7	AD3	10	D1	12				
pr1_edio_data_in6	AD2	10	F3	12				
pr1_edio_data_in5	AE6	10	F2	12				
pr1_edio_data_in4	AE2	10	G6	12				
pr1_edio_data_in3	AE1	10	G1	12				
pr1_edio_data_in2	AE5	10	H7	12				
pr1_edio_data_in1	AE3	10	G2	12				
pr1_edio_data_in0	AF1	10	E1	12				
pr1_edio_sof	AF4	10	F4	11				
pr1_edc_latch0_in	AG3	10	E2	11	D18	12		
pr1_edc_latch1_in	AG5	10						
pr1_edc_sync1_out	AF6	10						
pr1_edc_sync0_out	AF2	10	D2	11	B18	13		
pr1_edio_latch_in	AF3	10						
pr1_uart0_cts_n	G1	11	F11	10				
pr1_uart0_rts_n	G6	11	G10	10				
pr1_uart0_txd	F3	11	G11	10				
pr1_uart0_rxd	F2	11	F10	10				
pr1_ecap0_ecap_capin_apwm_o	D1	11	E9	10				
<b>PRU-ICSS1 MII</b>								
pr1_mii1_txd3	F5	11					F5	11
pr1_mii1_txd2	E6	11					E6	11
pr1_mii1_txd1	D5	11					D2	13
pr1_mii1_txd0	C2	11					F4	13
pr1_mii1_rxd3	B2	11					E9	12

**Table 5-188. PRU-ICSS1 IOSETs (continued)**

SIGNALS	IOSET1		IOSET2		IOSET3 <sup>(1) (2)</sup>		IOSET4 <sup>(1) (2)</sup>	
	BALL	MUX	BALL	MUX	BALL	MUX	BALL	MUX
pr1_mii1_rxd2	D6	11					F9	12
pr1_mii1_rxd1	C5	11					F8	12
pr1_mii1_rxd0	A3	11					E7	12
pr1_mii1_rxdv	C4	11					G11	12
pr1_mii1_txen	E4	11					E4	11
pr1_mii1_rxer	B3	11					E11	12
pr1_mii_mr1_clk	C3	11					F10	12
pr1_mii_mt1_clk	C1	11					C1	11
pr1_mii0_txd3	V5	11			D9	13		
pr1_mii0_txd2	V4	11			D7	13		
pr1_mii0_txd1	Y2	11			A5	13		
pr1_mii0_txd0	W2	11			C6	13		
pr1_mii0_rxd3	W9	11			B7	12		
pr1_mii0_rxd2	V9	11			B8	12		
pr1_mii0_rxd1	V6	11			A7	12		
pr1_mii0_rxd0	U6	11			A8	12		
pr1_mii0_rxdv	V2	11			C7	12		
pr1_mii0_txen	V3	11			D8	13		
pr1_mii0_rxer	U7	11			C9	12		
pr1_mii_mt0_clk	U5	11			E8	12		
pr1_mii_mr0_clk	Y1	11			C8	12		
pr1_mdio_mdclk	D3	11						
pr1_mdio_data	F6	11						
pr1_mii1_crs	A4	11					G10	12
pr1_mii1_rxlink	B4	11					F11	12
pr1_mii1_col	B5	11					E2	12
pr1_mii0_col	V1	11			B9	12		
pr1_mii0_rxlink	U4	11			A9	12		
pr1_mii0_crs	V7	11			A10	12		

(1) These signals are internally muxed with the PRU GPI/GPO signals. When PRUSS1\_MII pins are selected from IOSET3, the PRUSS internal wrapper multiplexing must be configured for PRUSS\_MII functionality (or MII2 mode). In this configuration, the PRU pins listed below are not available for any other I/O functionality and cannot be selected. Refer to the PRU chapter in the device TRM for more details about the PRU-ICSS internal wrapper multiplexing.

- PRUSS1\_MII0 pins selected from IOSET3:
  - pr2\_pru1\_\* cannot be used.
- PRUSS1\_MII1 pins selected from IOSET4:
  - pr1\_pru1\_\*, pr2\_pru0\_\*, pr2\_pru1\_\* cannot be used.

(2) These IOSETS (PRU-ICSS1 IOSET3 and IOSET4) are combined in the TI PinMux Tool and renamed PRUSS1\_MII\_IOSET\_3.

**Table 5-189. PRU-ICSS2 IOSETs**

SIGNALS	IOSET1		IOSET2	
	BALL	MUX	BALL	MUX
<b>PRU-ICSS2</b>				
pr2_pru1_gpi20	F10	12	F10	12
pr2_pru1_gpi19	G10	12	G10	12
pr2_pru1_gpi18	F11	12	F11	12
pr2_pru1_gpi17	E11	12	E11	12
pr2_pru1_gpi16	W2	12	G14	12

Table 5-189. PRU-ICSS2 IOSETs (continued)

SIGNALS	IOSET1		IOSET2	
	BALL	MUX	BALL	MUX
pr2_pru1_gpi15	Y2	12	A13	12
pr2_pru1_gpi14	V3	12	E14	12
pr2_pru1_gpi13	V4	12	A12	12
pr2_pru1_gpi12	V5	12	B13	12
pr2_pru1_gpi11	U5	12	A11	12
pr2_pru1_gpi10	U6	12	B12	12
pr2_pru1_gpi9	V6	12	F12	12
pr2_pru1_gpi8	U7	12	G12	12
pr2_pru1_gpi7	V7	12	C14	12
pr2_pru1_gpi6	V9	12	E17	12
pr2_pru1_gpi5	W9	12	D18	12
pr2_pru1_gpi4	Y1	12	AA4	12
pr2_pru1_gpi3	V2	12	AB3	12
pr2_pru1_gpi2	U3	12	AB9	12
pr2_pru1_gpi1	U4	12	AA3	12
pr2_pru1_gpi0	V1	12	D17	12
pr2_pru1_gpo20	F10	13	F10	13
pr2_pru1_gpo19	G10	13	G10	13
pr2_pru1_gpo18	F11	13	F11	13
pr2_pru1_gpo17	E11	13	E11	13
pr2_pru1_gpo16	W2	13	G14	13
pr2_pru1_gpo15	Y2	13	A13	13
pr2_pru1_gpo14	V3	13	E14	13
pr2_pru1_gpo13	V4	13	A12	13
pr2_pru1_gpo12	V5	13	B13	13
pr2_pru1_gpo11	U5	13	A11	13
pr2_pru1_gpo10	U6	13	B12	13
pr2_pru1_gpo9	V6	13	F12	13
pr2_pru1_gpo8	U7	13	G12	13
pr2_pru1_gpo7	V7	13	C14	13
pr2_pru1_gpo6	V9	13	E17	13
pr2_pru1_gpo5	W9	13	D18	13
pr2_pru1_gpo4	Y1	13	AA4	13
pr2_pru1_gpo3	V2	13	AB3	13
pr2_pru1_gpo2	U3	13	AB9	13
pr2_pru1_gpo1	U4	13	AA3	13
pr2_pru1_gpo0	V1	13	D17	13
pr2_pru0_gpi20	A10	12	F14	12
pr2_pru0_gpi19	B9	12	A18	12
pr2_pru0_gpi18	A9	12	A19	12
pr2_pru0_gpi17	C9	12	A16	12
pr2_pru0_gpi16	A8	12	C15	12
pr2_pru0_gpi15	A7	12	C17	12
pr2_pru0_gpi14	B8	12	B19	12
pr2_pru0_gpi13	B7	12	F15	12
pr2_pru0_gpi12	C7	12	B18	12

**Table 5-189. PRU-ICSS2 IOSETs (continued)**

SIGNALS	IOSET1		IOSET2	
	BALL	MUX	BALL	MUX
pr2_pru0_gpi11	C8	12	AB5	12
pr2_pru0_gpi10	C6	12	AB8	12
pr2_pru0_gpi9	A5	12	AD6	12
pr2_pru0_gpi8	D8	12	AC8	12
pr2_pru0_gpi7	D7	12	AC3	12
pr2_pru0_gpi6	D9	12	AC9	12
pr2_pru0_gpi5	E8	12	AC6	12
pr2_pru0_gpi4	E7	12	AC7	12
pr2_pru0_gpi3	F8	12	AC4	12
pr2_pru0_gpi2	F9	12	AD4	12
pr2_pru0_gpi1	E9	12	AB4	12
pr2_pru0_gpi0	G11	12	AC5	12
pr2_pru0_gpo20	A10	13	F14	13
pr2_pru0_gpo19	B9	13	A18	13
pr2_pru0_gpo18	A9	13	A19	13
pr2_pru0_gpo17	C9	13	A16	13
pr2_pru0_gpo16	A8	13	C15	13
pr2_pru0_gpo15	A7	13	C17	13
pr2_pru0_gpo14	B8	13	B19	13
pr2_pru0_gpo13	B7	13	F15	13
pr2_pru0_gpo12	C7	13	B18	13
pr2_pru0_gpo11	C8	13	AB5	13
pr2_pru0_gpo10	C6	13	AB8	13
pr2_pru0_gpo9	A5	13	AD6	13
pr2_pru0_gpo8	D8	13	AC8	13
pr2_pru0_gpo7	D7	13	AC3	13
pr2_pru0_gpo6	D9	13	AC9	13
pr2_pru0_gpo5	E8	13	AC6	13
pr2_pru0_gpo4	E7	13	AC7	13
pr2_pru0_gpo3	F8	13	AC4	13
pr2_pru0_gpo2	F9	13	AD4	13
pr2_pru0_gpo1	E9	13	AB4	13
pr2_pru0_gpo0	G11	13	AC5	13
pr2_edio_data_out7	A10	11		
pr2_edio_data_out6	B9	11		
pr2_edio_data_out5	A9	11		
pr2_edio_data_out4	C9	11		
pr2_edio_data_out3	A8	11		
pr2_edio_data_out2	A7	11		
pr2_edio_data_out1	B8	11		
pr2_edio_data_out0	B7	11		
pr2_edio_data_in7	A10	10		
pr2_edio_data_in6	B9	10		
pr2_edio_data_in5	A9	10		
pr2_edio_data_in4	C9	10		
pr2_edio_data_in3	A8	10		

Table 5-189. PRU-ICSS2 IOSETs (continued)

SIGNALS	IOSET1		IOSET2	
	BALL	MUX	BALL	MUX
pr2_edio_data_in2	A7	10		
pr2_edio_data_in1	B8	10		
pr2_edio_data_in0	B7	10		
pr2_edio_latch_in	D9	10		
pr2_edio_sof	D7	10		
pr2_edc_sync0_out	E7	10	F15	13
pr2_edc_sync1_out	E8	10		
pr2_edc_latch0_in	F9	10	E17	12
pr2_edc_latch1_in	F8	10		
pr2_uart0_rxd	C6	10		
pr2_uart0_txd	C8	10		
pr2_uart0_cts_n	D8	10		
pr2_uart0_rts_n	A5	10		
pr2_ecap0_ecap_capin_apwm_o	C7	10		
<b>PRU-ICSS2 MII</b>				
pr2_mii1_txd3	AD4	11		
pr2_mii1_txd2	AC4	11		
pr2_mii1_txd1	AC7	11		
pr2_mii1_txd0	AC6	11		
pr2_mii1_rxd3	AC8	11		
pr2_mii1_rxd2	AD6	11		
pr2_mii1_rxd1	AB8	11		
pr2_mii1_rxd0	AB5	11		
pr2_mii_mr1_clk	AC9	11		
pr2_mii1_rxer	B19	11		
pr2_mii_mt1_clk	AC5	11		
pr2_mii1_rxdv	AC3	11		
pr2_mii1_txen	AB4	11		
pr2_mii0_txd3	A11	11		
pr2_mii0_txd2	B13	11		
pr2_mii0_txd1	A12	11		
pr2_mii0_txd0	E14	11		
pr2_mii0_rxd3	F14	11		
pr2_mii0_rxd2	A19	11		
pr2_mii0_rxd1	A18	11		
pr2_mii0_rxd0	C15	11		
pr2_mii_mr0_clk	A13	11		
pr2_mii0_rxer	G12	11		
pr2_mii_mt0_clk	F12	11		
pr2_mii0_rxdv	G14	11		
pr2_mii0_txen	B12	11		
pr2_mdio_mdclk	C14	11	AB3	11
pr2_mdio_data	D14	11	AA4	11
pr2_mii1_crs	E17	11		
pr2_mii1_rxlink	C17	11		
pr2_mii0_crs	B18	11		



**Table 5-189. PRU-ICSS2 IOSETs (continued)**

SIGNALS	IOSET1		IOSET2	
	BALL	MUX	BALL	MUX
pr2_mii0_rxlink	A16	11		
pr2_mii0_col	F15	11		
pr2_mii1_col	D18	11		

**Table 5-190. PRU-ICSS2 IOSETs (EnDAT)**

SIGNALS	IOSET1		IOSET3	
	BALL	MUX	BALL	MUX
pr2_pru1_endat0_clk	V1	13	D17	13
pr2_pru1_endat0_out	U4	13	AA3	13
pr2_pru1_endat0_out_en	U3	13	AB9	13
pr2_pru1_endat1_clk	V2	13	AB3	13
pr2_pru1_endat1_out	Y1	13	AA4	13
pr2_pru1_endat1_out_en	W9	13	D18	13
pr2_pru1_endat2_clk	V9	13	E17	13
pr2_pru1_endat2_out	V7	13	C14	13
pr2_pru1_endat2_out_en	U7	13	G12	13
pr2_pru1_endat0_in	V6	12	F12	12
pr2_pru1_endat1_in	U6	12	B12	12
pr2_pru1_endat2_in	U5	12	A11	12
pr2_pru0_endat0_clk	AC5	13	G11	13
pr2_pru0_endat0_out	AB4	13	E9	13
pr2_pru0_endat0_out_en	AD4	13	F9	13
pr2_pru0_endat1_clk	AC4	13	F8	13
pr2_pru0_endat1_out	AC7	13	E7	13
pr2_pru0_endat1_out_en	AC6	13	E8	13
pr2_pru0_endat2_clk	AC9	13	D9	13
pr2_pru0_endat2_out	AC3	13	D7	13
pr2_pru0_endat2_out_en	AC8	13	D8	13
pr2_pru0_endat0_in	AD6	12	A5	12
pr2_pru0_endat1_in	AB8	12	C6	12
pr2_pru0_endat2_in	AB5	12	C8	12

**Table 5-191. PRU-ICSS2 IOSETs (Sigma Delta)**

SIGNALS	IOSET1		IOSET3	
	BALL	MUX	BALL	MUX
pr2_pru1_sd0_clk	V1	12	D17	12
pr2_pru1_sd0_d	U4	12	AA3	12
pr2_pru1_sd1_clk	U3	12	AB9	12
pr2_pru1_sd1_d	V2	12	AB3	12
pr2_pru1_sd2_clk	Y1	12	AA4	12
pr2_pru1_sd2_d	W9	12	D18	12
pr2_pru1_sd3_clk	V9	12	E17	12
pr2_pru1_sd3_d	V7	12	C14	12
pr2_pru1_sd4_clk	U7	12	G12	12

Table 5-191. PRU-ICSS2 IOSETs (Sigma Delta) (continued)

SIGNALS	IOSET1		IOSET3	
	BALL	MUX	BALL	MUX
pr2_pru1_sd4_d	V6	12	F12	12
pr2_pru1_sd5_clk	U6	12	B12	12
pr2_pru1_sd5_d	U5	12	A11	12
pr2_pru1_sd6_clk	V5	12	B13	12
pr2_pru1_sd6_d	V4	12	A12	12
pr2_pru1_sd7_clk	V3	12	E14	12
pr2_pru1_sd7_d	Y2	12	A13	12
pr2_pru1_sd8_clk	W2	12	G14	12
pr2_pru1_sd8_d	E11	12	E11	12
pr2_pru0_sd0_clk	G11	12	AC5	12
pr2_pru0_sd0_d	E9	12	AB4	12
pr2_pru0_sd1_clk	F9	12	AD4	12
pr2_pru0_sd1_d	F8	12	AC4	12
pr2_pru0_sd2_clk	E7	12	AC7	12
pr2_pru0_sd2_d	E8	12	AC6	12
pr2_pru0_sd3_clk	D9	12	AC9	12
pr2_pru0_sd3_d	D7	12	AC3	12
pr2_pru0_sd4_clk	D8	12	AC8	12
pr2_pru0_sd4_d	A5	12	AD6	12
pr2_pru0_sd5_clk	C6	12	AB8	12
pr2_pru0_sd5_d	C8	12	AB5	12
pr2_pru0_sd6_clk	C7	12	B18	12
pr2_pru0_sd6_d	B7	12	F15	12
pr2_pru0_sd7_clk	B8	12	B19	12
pr2_pru0_sd7_d	A7	12	C17	12
pr2_pru0_sd8_clk	A8	12	C15	12
pr2_pru0_sd8_d	C9	12	A16	12

#### 5.10.6.20.6 PRU-ICSS Manual Functional Mapping

#### NOTE

To configure the desired manual IO timing mode the user must follow the steps described in *Manual IO Timing Modes* section in the device TRM.

The associated registers to configure are listed in the **CFG REGISTER** column. For more information, see *Control Module* chapter in the device TRM.

Manual IO Timings Modes must be used to ensure some IO timings for PRU-ICSS1 PRU0 Direct Output mode. See [Table 5-33, Modes Summary](#) for a list of IO timings requiring the use of Manual IO Timings Modes. See [Table 5-192, Manual Functions Mapping for PRU-ICSS1 PRU0 Direct Output mode](#) for a definition of the Manual modes.

[Table 5-192](#) lists the A\_DELAY and G\_DELAY values needed to calculate the correct values to be set in the CFG\_x registers.

**Table 5-192. Manual Functions Mapping for PRU-ICSS1 PRU0 Direct Output mode**

BALL	BALL NAME	PR1_PRU0_DIR_OUT_MANUAL		CFG REGISTER	MUXMODE
		A_DELAY (ps)	G_DELAY (ps)		13
AG3	vin1a_d10	0	600	CFG_VIN1A_D10_OUT	pr1_pru0_gpo7
AG5	vin1a_d11	0	0	CFG_VIN1A_D11_OUT	pr1_pru0_gpo8
AF2	vin1a_d12	0	2400	CFG_VIN1A_D12_OUT	pr1_pru0_gpo9
AF6	vin1a_d13	0	200	CFG_VIN1A_D13_OUT	pr1_pru0_gpo10
AF3	vin1a_d14	0	900	CFG_VIN1A_D14_OUT	pr1_pru0_gpo11
AF4	vin1a_d15	0	0	CFG_VIN1A_D15_OUT	pr1_pru0_gpo12
AF1	vin1a_d16	0	100	CFG_VIN1A_D16_OUT	pr1_pru0_gpo13
AE3	vin1a_d17	0	300	CFG_VIN1A_D17_OUT	pr1_pru0_gpo14
AE5	vin1a_d18	0	0	CFG_VIN1A_D18_OUT	pr1_pru0_gpo15
AE1	vin1a_d19	0	400	CFG_VIN1A_D19_OUT	pr1_pru0_gpo16
AE2	vin1a_d20	0	300	CFG_VIN1A_D20_OUT	pr1_pru0_gpo17
AE6	vin1a_d21	0	500	CFG_VIN1A_D21_OUT	pr1_pru0_gpo18
AD2	vin1a_d22	0	0	CFG_VIN1A_D22_OUT	pr1_pru0_gpo19
AD3	vin1a_d23	0	500	CFG_VIN1A_D23_OUT	pr1_pru0_gpo20
AH6	vin1a_d3	0	1400	CFG_VIN1A_D3_OUT	pr1_pru0_gpo0
AH3	vin1a_d4	0	2600	CFG_VIN1A_D4_OUT	pr1_pru0_gpo1
AH5	vin1a_d5	0	0	CFG_VIN1A_D5_OUT	pr1_pru0_gpo2
AG6	vin1a_d6	0	0	CFG_VIN1A_D6_OUT	pr1_pru0_gpo3
AH4	vin1a_d7	0	0	CFG_VIN1A_D7_OUT	pr1_pru0_gpo4
AG4	vin1a_d8	0	0	CFG_VIN1A_D8_OUT	pr1_pru0_gpo5
AG2	vin1a_d9	0	300	CFG_VIN1A_D9_OUT	pr1_pru0_gpo6

Manual IO Timings Modes must be used to ensure some IO timings for PRU-ICSS1 PRU1 Direct Output mode. See [Table 5-33, Modes Summary](#) for a list of IO timings requiring the use of Manual IO Timings Modes. See [Table 5-193, Manual Functions Mapping for PRU-ICSS1 PRU1 Direct Output mode](#) for a definition of the Manual modes.

[Table 5-193](#) lists the A\_DELAY and G\_DELAY values needed to calculate the correct values to be set in the CFG\_x registers.

**Table 5-193. Manual Functions Mapping for PRU-ICSS1 PRU1 Direct Output mode**

BALL	BALL NAME	PR1_PRU1_DIR_OUT_MANUAL		CFG REGISTER	MUXMODE
		A_DELAY (ps)	G_DELAY (ps)		13
D3	vin2a_d10	0	300	CFG_VIN2A_D10_OUT	pr1_pru1_gpo7
F6	vin2a_d11	0	800	CFG_VIN2A_D11_OUT	pr1_pru1_gpo8
D5	vin2a_d12	0	1800	CFG_VIN2A_D12_OUT	pr1_pru1_gpo9
C2	vin2a_d13	0	1600	CFG_VIN2A_D13_OUT	pr1_pru1_gpo10
C3	vin2a_d14	0	1400	CFG_VIN2A_D14_OUT	pr1_pru1_gpo11
C4	vin2a_d15	0	1300	CFG_VIN2A_D15_OUT	pr1_pru1_gpo12
B2	vin2a_d16	0	1100	CFG_VIN2A_D16_OUT	pr1_pru1_gpo13
D6	vin2a_d17	0	1400	CFG_VIN2A_D17_OUT	pr1_pru1_gpo14
C5	vin2a_d18	0	200	CFG_VIN2A_D18_OUT	pr1_pru1_gpo15
A3	vin2a_d19	0	600	CFG_VIN2A_D19_OUT	pr1_pru1_gpo16
B3	vin2a_d20	0	200	CFG_VIN2A_D20_OUT	pr1_pru1_gpo17
B4	vin2a_d21	0	0	CFG_VIN2A_D21_OUT	pr1_pru1_gpo18
B5	vin2a_d22	0	0	CFG_VIN2A_D22_OUT	pr1_pru1_gpo19
A4	vin2a_d23	0	0	CFG_VIN2A_D23_OUT	pr1_pru1_gpo20

**Table 5-193. Manual Functions Mapping for PRU-ICSS1 PRU1 Direct Output mode (continued)**

BALL	BALL NAME	PR1_PRU1_DIR_OUT_MANUAL		CFG REGISTER	MUXMODE
		A_DELAY (ps)	G_DELAY (ps)		13
E2	vin2a_d3	0	1700	CFG_VIN2A_D3_OUT	pr1_pru1_gpo0
D2	vin2a_d4	0	2800	CFG_VIN2A_D4_OUT	pr1_pru1_gpo1
F4	vin2a_d5	0	200	CFG_VIN2A_D5_OUT	pr1_pru1_gpo2
C1	vin2a_d6	0	1100	CFG_VIN2A_D6_OUT	pr1_pru1_gpo3
E4	vin2a_d7	0	1200	CFG_VIN2A_D7_OUT	pr1_pru1_gpo4
F5	vin2a_d8	0	1100	CFG_VIN2A_D8_OUT	pr1_pru1_gpo5
E6	vin2a_d9	0	700	CFG_VIN2A_D9_OUT	pr1_pru1_gpo6

Manual IO Timings Modes must be used to ensure some IO timings for PRU-ICSS1 PRU0 Direct Input mode. See [Table 5-33, Modes Summary](#) for a list of IO timings requiring the use of Manual IO Timings Modes. See [Table 5-194, Manual Functions Mapping for PRU-ICSS1 PRU0 Direct Input mode](#) for a definition of the Manual modes.

[Table 5-194](#) lists the A\_DELAY and G\_DELAY values needed to calculate the correct values to be set in the CFG\_x registers.

**Table 5-194. Manual Functions Mapping for PRU-ICSS1 PRU0 Direct Input mode**

BALL	BALL NAME	PR1_PRU0_DIR_IN_MANUAL		CFG REGISTER	MUXMODE
		A_DELAY (ps)	G_DELAY (ps)		12
AG3	vin1a_d10	0	500	CFG_VIN1A_D10_IN	pr1_pru0_gpi7
AG5	vin1a_d11	0	0	CFG_VIN1A_D11_IN	pr1_pru0_gpi8
AF2	vin1a_d12	0	800	CFG_VIN1A_D12_IN	pr1_pru0_gpi9
AF6	vin1a_d13	0	300	CFG_VIN1A_D13_IN	pr1_pru0_gpi10
AF3	vin1a_d14	0	600	CFG_VIN1A_D14_IN	pr1_pru0_gpi11
AF4	vin1a_d15	0	1100	CFG_VIN1A_D15_IN	pr1_pru0_gpi12
AF1	vin1a_d16	0	800	CFG_VIN1A_D16_IN	pr1_pru0_gpi13
AE3	vin1a_d17	0	1000	CFG_VIN1A_D17_IN	pr1_pru0_gpi14
AE5	vin1a_d18	0	1100	CFG_VIN1A_D18_IN	pr1_pru0_gpi15
AE1	vin1a_d19	0	2500	CFG_VIN1A_D19_IN	pr1_pru0_gpi16
AE2	vin1a_d20	0	900	CFG_VIN1A_D20_IN	pr1_pru0_gpi17
AE6	vin1a_d21	0	800	CFG_VIN1A_D21_IN	pr1_pru0_gpi18
AD2	vin1a_d22	0	900	CFG_VIN1A_D22_IN	pr1_pru0_gpi19
AD3	vin1a_d23	0	500	CFG_VIN1A_D23_IN	pr1_pru0_gpi20
AH6	vin1a_d3	0	500	CFG_VIN1A_D3_IN	pr1_pru0_gpi0
AH3	vin1a_d4	0	0	CFG_VIN1A_D4_IN	pr1_pru0_gpi1
AH5	vin1a_d5	0	900	CFG_VIN1A_D5_IN	pr1_pru0_gpi2
AG6	vin1a_d6	0	400	CFG_VIN1A_D6_IN	pr1_pru0_gpi3
AH4	vin1a_d7	0	500	CFG_VIN1A_D7_IN	pr1_pru0_gpi4
AG4	vin1a_d8	0	0	CFG_VIN1A_D8_IN	pr1_pru0_gpi5
AG2	vin1a_d9	0	600	CFG_VIN1A_D9_IN	pr1_pru0_gpi6

Manual IO Timings Modes must be used to ensure some IO timings for PRU-ICSS1 PRU1 Direct Input mode. See [Table 5-33, Modes Summary](#) for a list of IO timings requiring the use of Manual IO Timings Modes. See [Table 5-195, Manual Functions Mapping for PRU-ICSS1 PRU1 Direct Input mode](#) for a definition of the Manual modes.

[Table 5-195](#) lists the A\_DELAY and G\_DELAY values needed to calculate the correct values to be set in the CFG\_x registers.

**Table 5-195. Manual Functions Mapping for PRU-ICSS1 PRU1 Direct Input mode**

BALL	BALL NAME	PR1_PRU1_DIR_IN_MANUAL		CFG REGISTER	MUXMODE
		A_DELAY (ps)	G_DELAY (ps)		12
D3	vin2a_d10	0	1600	CFG_VIN2A_D10_IN	pr1_pru1_gpi7
F6	vin2a_d11	0	1000	CFG_VIN2A_D11_IN	pr1_pru1_gpi8
D5	vin2a_d12	0	1400	CFG_VIN2A_D12_IN	pr1_pru1_gpi9
C2	vin2a_d13	0	1000	CFG_VIN2A_D13_IN	pr1_pru1_gpi10
C3	vin2a_d14	0	0	CFG_VIN2A_D14_IN	pr1_pru1_gpi11
C4	vin2a_d15	0	1000	CFG_VIN2A_D15_IN	pr1_pru1_gpi12
B2	vin2a_d16	0	1200	CFG_VIN2A_D16_IN	pr1_pru1_gpi13
D6	vin2a_d17	0	1300	CFG_VIN2A_D17_IN	pr1_pru1_gpi14
C5	vin2a_d18	0	2000	CFG_VIN2A_D18_IN	pr1_pru1_gpi15
A3	vin2a_d19	0	1100	CFG_VIN2A_D19_IN	pr1_pru1_gpi16
B3	vin2a_d20	0	1700	CFG_VIN2A_D20_IN	pr1_pru1_gpi17
B4	vin2a_d21	0	1300	CFG_VIN2A_D21_IN	pr1_pru1_gpi18
B5	vin2a_d22	0	1200	CFG_VIN2A_D22_IN	pr1_pru1_gpi19
A4	vin2a_d23	0	1300	CFG_VIN2A_D23_IN	pr1_pru1_gpi20
E2	vin2a_d3	0	2100	CFG_VIN2A_D3_IN	pr1_pru1_gpi0
D2	vin2a_d4	0	1000	CFG_VIN2A_D4_IN	pr1_pru1_gpi1
F4	vin2a_d5	0	1700	CFG_VIN2A_D5_IN	pr1_pru1_gpi2
C1	vin2a_d6	0	700	CFG_VIN2A_D6_IN	pr1_pru1_gpi3
E4	vin2a_d7	0	1300	CFG_VIN2A_D7_IN	pr1_pru1_gpi4
F5	vin2a_d8	0	1700	CFG_VIN2A_D8_IN	pr1_pru1_gpi5
E6	vin2a_d9	0	1600	CFG_VIN2A_D9_IN	pr1_pru1_gpi6

Manual IO Timings Modes must be used to ensure some IO timings for PRU-ICSS1 PRU0 Parallel Capture mode. See [Table 5-33, Modes Summary](#) for a list of IO timings requiring the use of Manual IO Timings Modes. See [Table 5-196, Manual Functions Mapping for PRU-ICSS1 PRU0 Parallel Capture mode](#) for a definition of the Manual modes.

[Table 5-196](#) lists the A\_DELAY and G\_DELAY values needed to calculate the correct values to be set in the CFG\_x registers.

**Table 5-196. Manual Functions Mapping for PRU-ICSS1 PRU0 Parallel Capture mode**

BALL	BALL NAME	PR1_PRU0_PAR_CAP_MANUAL		CFG REGISTER	MUXMODE
		A_DELAY (ps)	G_DELAY (ps)		12
AG3	vin1a_d10	1116	0	CFG_VIN1A_D10_IN	pr1_pru0_gpi7
AG5	vin1a_d11	834	0	CFG_VIN1A_D11_IN	pr1_pru0_gpi8
AF2	vin1a_d12	1186	0	CFG_VIN1A_D12_IN	pr1_pru0_gpi9
AF6	vin1a_d13	1095	0	CFG_VIN1A_D13_IN	pr1_pru0_gpi10
AF3	vin1a_d14	1243	0	CFG_VIN1A_D14_IN	pr1_pru0_gpi11
AF4	vin1a_d15	1315	0	CFG_VIN1A_D15_IN	pr1_pru0_gpi12
AF1	vin1a_d16	1190	0	CFG_VIN1A_D16_IN	pr1_pru0_gpi13
AE3	vin1a_d17	1313	0	CFG_VIN1A_D17_IN	pr1_pru0_gpi14
AE5	vin1a_d18	1269	0	CFG_VIN1A_D18_IN	pr1_pru0_gpi15
AE1	vin1a_d19	0	0	CFG_VIN1A_D19_IN	pr1_pru0_gpi16
AH6	vin1a_d3	963	0	CFG_VIN1A_D3_IN	pr1_pru0_gpi0
AH3	vin1a_d4	991	0	CFG_VIN1A_D4_IN	pr1_pru0_gpi1
AH5	vin1a_d5	1071	0	CFG_VIN1A_D5_IN	pr1_pru0_gpi2
AG6	vin1a_d6	986	0	CFG_VIN1A_D6_IN	pr1_pru0_gpi3

**Table 5-196. Manual Functions Mapping for PRU-ICSS1 PRU0 Parallel Capture mode (continued)**

BALL	BALL NAME	PR1_PRU0_PAR_CAP_MANUAL		CFG REGISTER	MUXMODE
		A_DELAY (ps)	G_DELAY (ps)		12
AH4	vin1a_d7	951	0	CFG_VIN1A_D7_IN	pr1_pru0_gpi4
AG4	vin1a_d8	960	0	CFG_VIN1A_D8_IN	pr1_pru0_gpi5
AG2	vin1a_d9	1269	0	CFG_VIN1A_D9_IN	pr1_pru0_gpi6

Manual IO Timings Modes must be used to ensure some IO timings for PRU-ICSS1 PRU1 Parallel Capture mode. See [Table 5-33, Modes Summary](#) for a list of IO timings requiring the use of Manual IO Timings Modes. See [Table 5-197, Manual Functions Mapping for PRU-ICSS1 PRU1 Parallel Capture mode](#) for a definition of the Manual modes.

[Table 5-197](#) lists the A\_DELAY and G\_DELAY values needed to calculate the correct values to be set in the CFG\_x registers.

**Table 5-197. Manual Functions Mapping for PRU-ICSS1 PRU1 Parallel Capture mode**

BALL	BALL NAME	PR1_PRU1_PAR_CAP_MANUAL		CFG REGISTER	MUXMODE
		A_DELAY (ps)	G_DELAY (ps)		12
D3	vin2a_d10	2410	799	CFG_VIN2A_D10_IN	pr1_pru1_gpi7
F6	vin2a_d11	2305	173	CFG_VIN2A_D11_IN	pr1_pru1_gpi8
D5	vin2a_d12	2261	513	CFG_VIN2A_D12_IN	pr1_pru1_gpi9
C2	vin2a_d13	2507	244	CFG_VIN2A_D13_IN	pr1_pru1_gpi10
C3	vin2a_d14	1992	0	CFG_VIN2A_D14_IN	pr1_pru1_gpi11
C4	vin2a_d15	2379	209	CFG_VIN2A_D15_IN	pr1_pru1_gpi12
B2	vin2a_d16	2278	339	CFG_VIN2A_D16_IN	pr1_pru1_gpi13
D6	vin2a_d17	2290	448	CFG_VIN2A_D17_IN	pr1_pru1_gpi14
C5	vin2a_d18	2546	1185	CFG_VIN2A_D18_IN	pr1_pru1_gpi15
A3	vin2a_d19	0	0	CFG_VIN2A_D19_IN	pr1_pru1_gpi16
E2	vin2a_d3	2651	685	CFG_VIN2A_D3_IN	pr1_pru1_gpi0
D2	vin2a_d4	2379	0	CFG_VIN2A_D4_IN	pr1_pru1_gpi1
F4	vin2a_d5	2607	747	CFG_VIN2A_D5_IN	pr1_pru1_gpi2
C1	vin2a_d6	2141	0	CFG_VIN2A_D6_IN	pr1_pru1_gpi3
E4	vin2a_d7	2339	441	CFG_VIN2A_D7_IN	pr1_pru1_gpi4
F5	vin2a_d8	2396	663	CFG_VIN2A_D8_IN	pr1_pru1_gpi5
E6	vin2a_d9	2384	443	CFG_VIN2A_D9_IN	pr1_pru1_gpi6

Manual IO Timings Modes must be used to ensure some IO timings for PRU-ICSS2 PRU0 IOSET1 Direct Input mode. See [Table 5-33, Modes Summary](#) for a list of IO timings requiring the use of Manual IO Timings Modes. See [Table 5-198, Manual Functions Mapping for PRU-ICSS2 PRU0 IOSET1 Direct Input mode](#) for a definition of the Manual modes.

[Table 5-198](#) lists the A\_DELAY and G\_DELAY values needed to calculate the correct values to be set in the CFG\_x registers.

**Table 5-198. Manual Functions Mapping for PRU-ICSS2 PRU0 IOSET1 Direct Input mode**

BALL	BALL NAME	PR2_PRU0_DIR_IN_MANUAL1		CFG REGISTER	MUXMODE
		A_DELAY (ps)	G_DELAY (ps)		12
D7	vout1_d10	0	100	CFG_VOUT1_D10_IN	pr2_pru0_gpi7
D8	vout1_d11	0	756	CFG_VOUT1_D11_IN	pr2_pru0_gpi8
A5	vout1_d12	0	531	CFG_VOUT1_D12_IN	pr2_pru0_gpi9
C6	vout1_d13	0	180	CFG_VOUT1_D13_IN	pr2_pru0_gpi10
C8	vout1_d14	0	334	CFG_VOUT1_D14_IN	pr2_pru0_gpi11

**Table 5-198. Manual Functions Mapping for PRU-ICSS2 PRU0 IOSET1 Direct Input mode (continued)**

BALL	BALL NAME	PR2_PRU0_DIR_IN_MANUAL1		CFG REGISTER	MUXMODE 12
		A_DELAY (ps)	G_DELAY (ps)		
C7	vout1_d15	0	1060	CFG_VOUT1_D15_IN	pr2_pru0_gpi12
B7	vout1_d16	0	488	CFG_VOUT1_D16_IN	pr2_pru0_gpi13
B8	vout1_d17	0	400	CFG_VOUT1_D17_IN	pr2_pru0_gpi14
A7	vout1_d18	0	254	CFG_VOUT1_D18_IN	pr2_pru0_gpi15
A8	vout1_d19	0	500	CFG_VOUT1_D19_IN	pr2_pru0_gpi16
C9	vout1_d20	0	716	CFG_VOUT1_D20_IN	pr2_pru0_gpi17
A9	vout1_d21	0	400	CFG_VOUT1_D21_IN	pr2_pru0_gpi18
B9	vout1_d22	0	404	CFG_VOUT1_D22_IN	pr2_pru0_gpi19
A10	vout1_d23	0	290	CFG_VOUT1_D23_IN	pr2_pru0_gpi20
G11	vout1_d3	0	226	CFG_VOUT1_D3_IN	pr2_pru0_gpi0
E9	vout1_d4	0	0	CFG_VOUT1_D4_IN	pr2_pru0_gpi1
F9	vout1_d5	0	365	CFG_VOUT1_D5_IN	pr2_pru0_gpi2
F8	vout1_d6	0	0	CFG_VOUT1_D6_IN	pr2_pru0_gpi3
E7	vout1_d7	0	218	CFG_VOUT1_D7_IN	pr2_pru0_gpi4
E8	vout1_d8	0	400	CFG_VOUT1_D8_IN	pr2_pru0_gpi5
D9	vout1_d9	0	500	CFG_VOUT1_D9_IN	pr2_pru0_gpi6

Manual IO Timings Modes must be used to ensure some IO timings for PRU-ICSS2 PRU0 IOSET2 Direct Input mode. See [Table 5-33, Modes Summary](#) for a list of IO timings requiring the use of Manual IO Timings Modes. See [Table 5-199, Manual Functions Mapping for PRU-ICSS2 PRU0 IOSET2 Direct Input mode](#) for a definition of the Manual modes.

[Table 5-199](#) lists the A\_DELAY and G\_DELAY values needed to calculate the correct values to be set in the CFG\_x registers.

**Table 5-199. Manual Functions Mapping for PRU-ICSS2 PRU0 IOSET2 Direct Input mode**

BALL	BALL NAME	PR2_PRU0_DIR_IN_MANUAL2		CFG REGISTER	MUXMODE 12
		A_DELAY (ps)	G_DELAY (ps)		
AC5	gpio6_10	1000	4200	CFG_GPIO6_10_IN	pr2_pru0_gpi0
AB4	gpio6_11	1000	4400	CFG_GPIO6_11_IN	pr2_pru0_gpi1
F14	mcasp1_axr15	0	1300	CFG_MCASP1_AXR15_IN	pr2_pru0_gpi20
A19	mcasp2_aclkx	0	700	CFG_MCASP2_ACLKX_IN	pr2_pru0_gpi18
C15	mcasp2_axr2	0	1800	CFG_MCASP2_AXR2_IN	pr2_pru0_gpi16
A16	mcasp2_axr3	0	1400	CFG_MCASP2_AXR3_IN	pr2_pru0_gpi17
A18	mcasp2_fsx	0	900	CFG_MCASP2_FSX_IN	pr2_pru0_gpi19
B18	mcasp3_aclkx	0	0	CFG_MCASP3_ACLKX_IN	pr2_pru0_gpi12
B19	mcasp3_axr0	0	1200	CFG_MCASP3_AXR0_IN	pr2_pru0_gpi14
C17	mcasp3_axr1	0	1200	CFG_MCASP3_AXR1_IN	pr2_pru0_gpi15
F15	mcasp3_fsx	0	1400	CFG_MCASP3_FSX_IN	pr2_pru0_gpi13
AD4	mmc3_clk	1000	4400	CFG_MMC3_CLK_IN	pr2_pru0_gpi2
AC4	mmc3_cmd	1000	4100	CFG_MMC3_CMD_IN	pr2_pru0_gpi3
AC7	mmc3_dat0	1000	4200	CFG_MMC3_DAT0_IN	pr2_pru0_gpi4
AC6	mmc3_dat1	1000	4500	CFG_MMC3_DAT1_IN	pr2_pru0_gpi5
AC9	mmc3_dat2	1000	4200	CFG_MMC3_DAT2_IN	pr2_pru0_gpi6
AC3	mmc3_dat3	1000	4500	CFG_MMC3_DAT3_IN	pr2_pru0_gpi7
AC8	mmc3_dat4	1000	3800	CFG_MMC3_DAT4_IN	pr2_pru0_gpi8
AD6	mmc3_dat5	1000	4300	CFG_MMC3_DAT5_IN	pr2_pru0_gpi9
AB8	mmc3_dat6	1000	4200	CFG_MMC3_DAT6_IN	pr2_pru0_gpi10

**Table 5-199. Manual Functions Mapping for PRU-ICSS2 PRU0 IOSET2 Direct Input mode (continued)**

BALL	BALL NAME	PR2_PRU0_DIR_IN_MANUAL2		CFG REGISTER	MUXMODE
		A_DELAY (ps)	G_DELAY (ps)		12
AB5	mmc3_dat7	1000	3700	CFG_MMC3_DAT7_IN	pr2_pru0_gpi11

Manual IO Timings Modes must be used to ensure some IO timings for PRU-ICSS2 PRU0 IOSET1 Direct Output mode. See [Table 5-33, Modes Summary](#) for a list of IO timings requiring the use of Manual IO Timings Modes. See [Table 5-200, Manual Functions Mapping for PRU-ICSS2 PRU0 IOSET1 Direct Output mode](#) for a definition of the Manual modes.

[Table 5-200](#) lists the A\_DELAY and G\_DELAY values needed to calculate the correct values to be set in the CFG\_x registers.

**Table 5-200. Manual Functions Mapping for PRU-ICSS2 PRU0 IOSET1 Direct Output mode**

BALL	BALL NAME	PR2_PRU0_DIR_OUT_MANUAL1		CFG REGISTER	MUXMODE
		A_DELAY (ps)	G_DELAY (ps)		13
D7	vout1_d10	0	0	CFG_VOUT1_D10_OUT	pr2_pru0_gpo7
D8	vout1_d11	0	500	CFG_VOUT1_D11_OUT	pr2_pru0_gpo8
A5	vout1_d12	0	1600	CFG_VOUT1_D12_OUT	pr2_pru0_gpo9
C6	vout1_d13	0	250	CFG_VOUT1_D13_OUT	pr2_pru0_gpo10
C8	vout1_d14	0	300	CFG_VOUT1_D14_OUT	pr2_pru0_gpo11
C7	vout1_d15	0	300	CFG_VOUT1_D15_OUT	pr2_pru0_gpo12
B7	vout1_d16	0	0	CFG_VOUT1_D16_OUT	pr2_pru0_gpo13
B8	vout1_d17	0	100	CFG_VOUT1_D17_OUT	pr2_pru0_gpo14
A7	vout1_d18	0	500	CFG_VOUT1_D18_OUT	pr2_pru0_gpo15
A8	vout1_d19	0	500	CFG_VOUT1_D19_OUT	pr2_pru0_gpo16
C9	vout1_d20	0	700	CFG_VOUT1_D20_OUT	pr2_pru0_gpo17
A9	vout1_d21	0	500	CFG_VOUT1_D21_OUT	pr2_pru0_gpo18
B9	vout1_d22	0	100	CFG_VOUT1_D22_OUT	pr2_pru0_gpo19
A10	vout1_d23	0	100	CFG_VOUT1_D23_OUT	pr2_pru0_gpo20
G11	vout1_d3	0	800	CFG_VOUT1_D3_OUT	pr2_pru0_gpo0
E9	vout1_d4	0	2000	CFG_VOUT1_D4_OUT	pr2_pru0_gpo1
F9	vout1_d5	0	550	CFG_VOUT1_D5_OUT	pr2_pru0_gpo2
F8	vout1_d6	0	600	CFG_VOUT1_D6_OUT	pr2_pru0_gpo3
E7	vout1_d7	0	400	CFG_VOUT1_D7_OUT	pr2_pru0_gpo4
E8	vout1_d8	0	100	CFG_VOUT1_D8_OUT	pr2_pru0_gpo5
D9	vout1_d9	0	500	CFG_VOUT1_D9_OUT	pr2_pru0_gpo6

Manual IO Timings Modes must be used to ensure some IO timings for PRU-ICSS2 PRU0 IOSET2 Direct Output mode. See [Table 5-33, Modes Summary](#) for a list of IO timings requiring the use of Manual IO Timings Modes. See [Table 5-201, Manual Functions Mapping for PRU-ICSS2 PRU0 IOSET2 Direct Output mode](#) for a definition of the Manual modes.

[Table 5-201](#) lists the A\_DELAY and G\_DELAY values needed to calculate the correct values to be set in the CFG\_x registers.

**Table 5-201. Manual Functions Mapping for PRU-ICSS2 PRU0 IOSET2 Direct Output mode**

BALL	BALL NAME	PR2_PRU0_DIR_OUT_MANUAL2		CFG REGISTER	MUXMODE
		A_DELAY (ps)	G_DELAY (ps)		13
AC5	gpio6_10	1000	3800	CFG_GPIO6_10_OUT	pr2_pru0_gpo0
AB4	gpio6_11	1000	4400	CFG_GPIO6_11_OUT	pr2_pru0_gpo1
F14	mcasp1_axr15	0	1300	CFG_MCASP1_AXR15_OUT	pr2_pru0_gpo20



**Table 5-201. Manual Functions Mapping for PRU-ICSS2 PRU0 IOSET2 Direct Output mode (continued)**

BALL	BALL NAME	PR2_PRU0_DIR_OUT_MANUAL2		CFG REGISTER	MUXMODE
		A_DELAY (ps)	G_DELAY (ps)		13
A19	mcasp2_aclkx	0	2500	CFG_MCASP2_ACLKX_OUT	pr2_pru0_gpo18
C15	mcasp2_axr2	0	1800	CFG_MCASP2_AXR2_OUT	pr2_pru0_gpo16
A16	mcasp2_axr3	0	1200	CFG_MCASP2_AXR3_OUT	pr2_pru0_gpo17
A18	mcasp2_fsx	0	0	CFG_MCASP2_FSX_OUT	pr2_pru0_gpo19
B18	mcasp3_aclkx	0	2300	CFG_MCASP3_ACLKX_OUT	pr2_pru0_gpo12
B19	mcasp3_axr0	0	300	CFG_MCASP3_AXR0_OUT	pr2_pru0_gpo14
C17	mcasp3_axr1	0	400	CFG_MCASP3_AXR1_OUT	pr2_pru0_gpo15
F15	mcasp3_fsx	0	400	CFG_MCASP3_FSX_OUT	pr2_pru0_gpo13
AD4	mmc3_clk	1000	4100	CFG_MMC3_CLK_OUT	pr2_pru0_gpo2
AC4	mmc3_cmd	1000	4200	CFG_MMC3_CMD_OUT	pr2_pru0_gpo3
AC7	mmc3_dat0	1000	3400	CFG_MMC3_DAT0_OUT	pr2_pru0_gpo4
AC6	mmc3_dat1	1000	3600	CFG_MMC3_DAT1_OUT	pr2_pru0_gpo5
AC9	mmc3_dat2	1000	3900	CFG_MMC3_DAT2_OUT	pr2_pru0_gpo6
AC3	mmc3_dat3	1000	3700	CFG_MMC3_DAT3_OUT	pr2_pru0_gpo7
AC8	mmc3_dat4	1000	4400	CFG_MMC3_DAT4_OUT	pr2_pru0_gpo8
AD6	mmc3_dat5	1000	4600	CFG_MMC3_DAT5_OUT	pr2_pru0_gpo9
AB8	mmc3_dat6	1000	4200	CFG_MMC3_DAT6_OUT	pr2_pru0_gpo10
AB5	mmc3_dat7	1000	4000	CFG_MMC3_DAT7_OUT	pr2_pru0_gpo11

Manual IO Timings Modes must be used to ensure some IO timings for PRU-ICSS2 PRU1 IOSET1 Direct Input mode. See [Table 5-33, Modes Summary](#) for a list of IO timings requiring the use of Manual IO Timings Modes. See [Table 5-202, Manual Functions Mapping for PRU-ICSS2 PRU1 IOSET1 Direct Input mode](#) for a definition of the Manual modes.

[Table 5-202](#) lists the A\_DELAY and G\_DELAY values needed to calculate the correct values to be set in the CFG\_x registers.

**Table 5-202. Manual Functions Mapping for PRU-ICSS2 PRU1 IOSET1 Direct Input mode**

BALL	BALL NAME	PR2_PRU1_DIR_IN_MANUAL1		CFG REGISTER	MUXMODE
		A_DELAY (ps)	G_DELAY (ps)		12
U3	RMII_MHZ_50_CLK	0	2500	CFG_RMII_MHZ_50_CLK_IN	pr2_pru1_gpi2
U4	mdio_d	0	3000	CFG_MDIO_D_IN	pr2_pru1_gpi1
V1	mdio_mclk	0	2422	CFG_MDIO_MCLK_IN	pr2_pru1_gpi0
U5	rgmii0_rxc	0	1904	CFG_RGMII0_RXC_IN	pr2_pru1_gpi11
V5	rgmii0_rxctl	0	3000	CFG_RGMII0_RXCTL_IN	pr2_pru1_gpi12
W2	rgmii0_rxd0	0	2800	CFG_RGMII0_RXD0_IN	pr2_pru1_gpi16
Y2	rgmii0_rxd1	0	3100	CFG_RGMII0_RXD1_IN	pr2_pru1_gpi15
V3	rgmii0_rxd2	0	2800	CFG_RGMII0_RXD2_IN	pr2_pru1_gpi14
V4	rgmii0_rxd3	0	3100	CFG_RGMII0_RXD3_IN	pr2_pru1_gpi13
W9	rgmii0_txc	0	2488	CFG_RGMII0_TXC_IN	pr2_pru1_gpi5
V9	rgmii0_txctl	0	2263	CFG_RGMII0_TXCTL_IN	pr2_pru1_gpi6
U6	rgmii0_txd0	0	2292	CFG_RGMII0_TXD0_IN	pr2_pru1_gpi10
V6	rgmii0_txd1	0	2900	CFG_RGMII0_TXD1_IN	pr2_pru1_gpi9
U7	rgmii0_txd2	0	2600	CFG_RGMII0_TXD2_IN	pr2_pru1_gpi8
V7	rgmii0_txd3	0	2600	CFG_RGMII0_TXD3_IN	pr2_pru1_gpi7
V2	uart3_rxd	0	1900	CFG_UART3_RXD_IN	pr2_pru1_gpi3
Y1	uart3_txd	0	1900	CFG_UART3_TXD_IN	pr2_pru1_gpi4
F11	vout1_d0	0	1300	CFG_VOUT1_D0_IN	pr2_pru1_gpi18

**Table 5-202. Manual Functions Mapping for PRU-ICSS2 PRU1 IOSET1 Direct Input mode (continued)**

BALL	BALL NAME	PR2_PRU1_DIR_IN_MANUAL1		CFG REGISTER	MUXMODE
		A_DELAY (ps)	G_DELAY (ps)		12
G10	vout1_d1	0	1300	CFG_VOUT1_D1_IN	pr2_pru1_gpi19
F10	vout1_d2	0	1100	CFG_VOUT1_D2_IN	pr2_pru1_gpi20
E11	vout1_vsync	0	0	CFG_VOUT1_VSYNC_IN	pr2_pru1_gpi17

Manual IO Timings Modes must be used to ensure some IO timings for PRU-ICSS2 PRU1 IOSET2 Direct Input mode. See [Table 5-33, Modes Summary](#) for a list of IO timings requiring the use of Manual IO Timings Modes. See [Table 5-203, Manual Functions Mapping for PRU-ICSS2 PRU1 IOSET2 Direct Input mode](#) for a definition of the Manual modes.

[Table 5-203](#) lists the A\_DELAY and G\_DELAY values needed to calculate the correct values to be set in the CFG\_x registers.

**Table 5-203. Manual Functions Mapping for PRU-ICSS2 PRU1 IOSET2 Direct Input mode**

BALL	BALL NAME	PR2_PRU1_DIR_IN_MANUAL2		CFG REGISTER	MUXMODE
		A_DELAY (ps)	G_DELAY (ps)		12
C14	mcasp1_aclkx	0	900	CFG_MCASP1_ACLKX_IN	pr2_pru1_gpi7
G12	mcasp1_axr0	0	1900	CFG_MCASP1_AXR0_IN	pr2_pru1_gpi8
F12	mcasp1_axr1	0	1250	CFG_MCASP1_AXR1_IN	pr2_pru1_gpi9
B13	mcasp1_axr10	0	1600	CFG_MCASP1_AXR10_IN	pr2_pru1_gpi12
A12	mcasp1_axr11	0	1700	CFG_MCASP1_AXR11_IN	pr2_pru1_gpi13
E14	mcasp1_axr12	0	1000	CFG_MCASP1_AXR12_IN	pr2_pru1_gpi14
A13	mcasp1_axr13	0	1300	CFG_MCASP1_AXR13_IN	pr2_pru1_gpi15
G14	mcasp1_axr14	0	1200	CFG_MCASP1_AXR14_IN	pr2_pru1_gpi16
B12	mcasp1_axr8	0	1450	CFG_MCASP1_AXR8_IN	pr2_pru1_gpi10
A11	mcasp1_axr9	0	1600	CFG_MCASP1_AXR9_IN	pr2_pru1_gpi11
D17	mcasp4_axr1	0	1600	CFG_MCASP4_AXR1_IN	pr2_pru1_gpi0
AA3	mcasp5_aclkx	800	3900	CFG_MCASP5_ACLKX_IN	pr2_pru1_gpi1
AB3	mcasp5_axr0	1100	4200	CFG_MCASP5_AXR0_IN	pr2_pru1_gpi3
AA4	mcasp5_axr1	1200	4200	CFG_MCASP5_AXR1_IN	pr2_pru1_gpi4
AB9	mcasp5_fsx	1000	3800	CFG_MCASP5_FSX_IN	pr2_pru1_gpi2
F11	vout1_d0	0	0	CFG_VOUT1_D0_IN	pr2_pru1_gpi18
G10	vout1_d1	0	0	CFG_VOUT1_D1_IN	pr2_pru1_gpi19
F10	vout1_d2	0	0	CFG_VOUT1_D2_IN	pr2_pru1_gpi20
E11	vout1_vsync	0	0	CFG_VOUT1_VSYNC_IN	pr2_pru1_gpi17
D18	xref_clk0	0	0	CFG_XREF_CLK0_IN	pr2_pru1_gpi5
E17	xref_clk1	0	750	CFG_XREF_CLK1_IN	pr2_pru1_gpi6

Manual IO Timings Modes must be used to ensure some IO timings for PRU-ICSS2 PRU1 IOSET1 Direct Output mode. See [Table 5-33, Modes Summary](#) for a list of IO timings requiring the use of Manual IO Timings Modes. See [Table 5-204, Manual Functions Mapping for PRU-ICSS2 PRU1 IOSET1 Direct Output mode](#) for a definition of the Manual modes.

[Table 5-204](#) lists the A\_DELAY and G\_DELAY values needed to calculate the correct values to be set in the CFG\_x registers.

**Table 5-204. Manual Functions Mapping for PRU-ICSS2 PRU1 IOSET1 Direct Output mode**

BALL	BALL NAME	PR2_PRU1_DIR_OUT_MANUAL1		CFG REGISTER	MUXMODE
		A_DELAY (ps)	G_DELAY (ps)		13
U3	RMII_MHZ_50_CLK	0	2600	CFG_RMII_MHZ_50_CLK_OUT	pr2_pru1_gpo2

**Table 5-204. Manual Functions Mapping for PRU-ICSS2 PRU1 IOSET1 Direct Output mode (continued)**

BALL	BALL NAME	PR2_PRU1_DIR_OUT_MANUAL1		CFG REGISTER	MUXMODE
		A_DELAY (ps)	G_DELAY (ps)		13
U4	mdio_d	0	3600	CFG_MDIO_D_OUT	pr2_pru1_gpo1
V1	mdio_mclk	0	3000	CFG_MDIO_MCLK_OUT	pr2_pru1_gpo0
U5	rgmii0_rxc	0	2700	CFG_RGMII0_RXC_OUT	pr2_pru1_gpo11
V5	rgmii0_rxctl	0	2800	CFG_RGMII0_RXCTL_OUT	pr2_pru1_gpo12
W2	rgmii0_rxd0	0	2800	CFG_RGMII0_RXD0_OUT	pr2_pru1_gpo16
Y2	rgmii0_rxd1	0	2600	CFG_RGMII0_RXD1_OUT	pr2_pru1_gpo15
V3	rgmii0_rxd2	0	2800	CFG_RGMII0_RXD2_OUT	pr2_pru1_gpo14
V4	rgmii0_rxd3	0	2700	CFG_RGMII0_RXD3_OUT	pr2_pru1_gpo13
W9	rgmii0_txc	0	3500	CFG_RGMII0_TXC_OUT	pr2_pru1_gpo5
V9	rgmii0_txctl	0	2700	CFG_RGMII0_TXCTL_OUT	pr2_pru1_gpo6
U6	rgmii0_txd0	0	3200	CFG_RGMII0_TXD0_OUT	pr2_pru1_gpo10
V6	rgmii0_txd1	0	2700	CFG_RGMII0_TXD1_OUT	pr2_pru1_gpo9
U7	rgmii0_txd2	0	3100	CFG_RGMII0_TXD2_OUT	pr2_pru1_gpo8
V7	rgmii0_txd3	0	3200	CFG_RGMII0_TXD3_OUT	pr2_pru1_gpo7
V2	uart3_rxd	0	3400	CFG_UART3_RXD_OUT	pr2_pru1_gpo3
Y1	uart3_txd	0	2700	CFG_UART3_TXD_OUT	pr2_pru1_gpo4
F11	vout1_d0	0	600	CFG_VOUT1_D0_OUT	pr2_pru1_gpo18
G10	vout1_d1	0	0	CFG_VOUT1_D1_OUT	pr2_pru1_gpo19
F10	vout1_d2	0	200	CFG_VOUT1_D2_OUT	pr2_pru1_gpo20
E11	vout1_vsync	0	1200	CFG_VOUT1_VSYNC_OUT	pr2_pru1_gpo17

Manual IO Timings Modes must be used to ensure some IO timings for PRU-ICSS2 PRU1 IOSET2 Direct Output mode. See [Table 5-33, Modes Summary](#) for a list of IO timings requiring the use of Manual IO Timings Modes. See [Table 5-205, Manual Functions Mapping for PRU-ICSS2 PRU1 IOSET2 Direct Output mode](#) for a definition of the Manual modes.

[Table 5-205](#) lists the A\_DELAY and G\_DELAY values needed to calculate the correct values to be set in the CFG\_x registers.

**Table 5-205. Manual Functions Mapping for PRU-ICSS2 PRU1 IOSET2 Direct Output mode**

BALL	BALL NAME	PR2_PRU1_DIR_OUT_MANUAL2		CFG REGISTER	MUXMODE
		A_DELAY (ps)	G_DELAY (ps)		13
C14	mcasp1_aclkx	0	1800	CFG_MCASP1_ACLKX_OUT	pr2_pru1_gpo7
G12	mcasp1_axr0	0	1000	CFG_MCASP1_AXR0_OUT	pr2_pru1_gpo8
F12	mcasp1_axr1	0	1400	CFG_MCASP1_AXR1_OUT	pr2_pru1_gpo9
B13	mcasp1_axr10	0	2300	CFG_MCASP1_AXR10_OUT	pr2_pru1_gpo12
A12	mcasp1_axr11	0	900	CFG_MCASP1_AXR11_OUT	pr2_pru1_gpo13
E14	mcasp1_axr12	0	1000	CFG_MCASP1_AXR12_OUT	pr2_pru1_gpo14
A13	mcasp1_axr13	0	1500	CFG_MCASP1_AXR13_OUT	pr2_pru1_gpo15
G14	mcasp1_axr14	0	2000	CFG_MCASP1_AXR14_OUT	pr2_pru1_gpo16
B12	mcasp1_axr8	0	2000	CFG_MCASP1_AXR8_OUT	pr2_pru1_gpo10
A11	mcasp1_axr9	0	800	CFG_MCASP1_AXR9_OUT	pr2_pru1_gpo11
D17	mcasp4_axr1	0	0	CFG_MCASP4_AXR1_OUT	pr2_pru1_gpo0
AA3	mcasp5_aclkx	1000	3900	CFG_MCASP5_ACLKX_OUT	pr2_pru1_gpo1
AB3	mcasp5_axr0	1000	3500	CFG_MCASP5_AXR0_OUT	pr2_pru1_gpo3
AA4	mcasp5_axr1	1000	2600	CFG_MCASP5_AXR1_OUT	pr2_pru1_gpo4
AB9	mcasp5_fsx	1000	2800	CFG_MCASP5_FSX_OUT	pr2_pru1_gpo2
F11	vout1_d0	0	0	CFG_VOUT1_D0_OUT	pr2_pru1_gpo18

**Table 5-205. Manual Functions Mapping for PRU-ICSS2 PRU1 IOSET2 Direct Output mode (continued)**

BALL	BALL NAME	PR2_PRU1_DIR_OUT_MANUAL2		CFG REGISTER	MUXMODE
		A_DELAY (ps)	G_DELAY (ps)		13
G10	vout1_d1	0	0	CFG_VOUT1_D1_OUT	pr2_pru1_gpo19
F10	vout1_d2	0	0	CFG_VOUT1_D2_OUT	pr2_pru1_gpo20
E11	vout1_vsync	0	0	CFG_VOUT1_VSYNC_OUT	pr2_pru1_gpo17
D18	xref_clk0	0	1600	CFG_XREF_CLK0_OUT	pr2_pru1_gpo5
E17	xref_clk1	0	1200	CFG_XREF_CLK1_OUT	pr2_pru1_gpo6

Manual IO Timings Modes must be used to ensure some IO timings for PRU-ICSS2 PRU0 IOSET1 Parallel Capture mode. See [Table 5-33, Modes Summary](#) for a list of IO timings requiring the use of Manual IO Timings Modes. See [Table 5-206, Manual Functions Mapping for PRU-ICSS2 PRU0 IOSET1 Parallel Capture mode](#) for a definition of the Manual modes.

[Table 5-206](#) lists the A\_DELAY and G\_DELAY values needed to calculate the correct values to be set in the CFG\_x registers.

**Table 5-206. Manual Functions Mapping for PRU-ICSS2 PRU0 IOSET1 Parallel Capture mode**

BALL	BALL NAME	PR2_PRU0_PAR_CAP_MANUAL1		CFG REGISTER	MUXMODE
		A_DELAY (ps)	G_DELAY (ps)		12
D7	vout1_d10	2072	0	CFG_VOUT1_D10_IN	pr2_pru0_gpi7
D8	vout1_d11	2201	0	CFG_VOUT1_D11_IN	pr2_pru0_gpi8
A5	vout1_d12	2088	0	CFG_VOUT1_D12_IN	pr2_pru0_gpi9
C6	vout1_d13	2047	0	CFG_VOUT1_D13_IN	pr2_pru0_gpi10
C8	vout1_d14	1865	0	CFG_VOUT1_D14_IN	pr2_pru0_gpi11
C7	vout1_d15	2338	0	CFG_VOUT1_D15_IN	pr2_pru0_gpi12
B7	vout1_d16	2011	0	CFG_VOUT1_D16_IN	pr2_pru0_gpi13
B8	vout1_d17	2353	0	CFG_VOUT1_D17_IN	pr2_pru0_gpi14
A7	vout1_d18	1814	0	CFG_VOUT1_D18_IN	pr2_pru0_gpi15
A8	vout1_d19	0	0	CFG_VOUT1_D19_IN	pr2_pru0_gpi16
G11	vout1_d3	2181	0	CFG_VOUT1_D3_IN	pr2_pru0_gpi0
E9	vout1_d4	1842	0	CFG_VOUT1_D4_IN	pr2_pru0_gpi1
F9	vout1_d5	1850	0	CFG_VOUT1_D5_IN	pr2_pru0_gpi2
F8	vout1_d6	1873	0	CFG_VOUT1_D6_IN	pr2_pru0_gpi3
E7	vout1_d7	1878	0	CFG_VOUT1_D7_IN	pr2_pru0_gpi4
E8	vout1_d8	2342	0	CFG_VOUT1_D8_IN	pr2_pru0_gpi5
D9	vout1_d9	2423	0	CFG_VOUT1_D9_IN	pr2_pru0_gpi6

Manual IO Timings Modes must be used to ensure some IO timings for PRU-ICSS2 PRU0 IOSET2 Parallel Capture mode. See [Table 5-33, Modes Summary](#) for a list of IO timings requiring the use of Manual IO Timings Modes. See [Table 5-207, Manual Functions Mapping for PRU-ICSS2 PRU0 IOSET2 Parallel Capture mode](#) for a definition of the Manual modes.

[Table 5-207](#) lists the A\_DELAY and G\_DELAY values needed to calculate the correct values to be set in the CFG\_x registers.

**Table 5-207. Manual Functions Mapping for PRU-ICSS2 PRU0 IOSET2 Parallel Capture mode**

BALL	BALL NAME	PR2_PRU0_PAR_CAP_MANUAL2		CFG REGISTER	MUXMODE
		A_DELAY (ps)	G_DELAY (ps)		12
AC5	gpio6_10	4358	1843	CFG_GPIO6_10_IN	pr2_pru0_gpi0
AB4	gpio6_11	4322	1888	CFG_GPIO6_11_IN	pr2_pru0_gpi1
C15	mcasp2_axr2	0	0	CFG_MCASP2_AXR2_IN	pr2_pru0_gpi16

**Table 5-207. Manual Functions Mapping for PRU-ICSS2 PRU0 IOSET2 Parallel Capture mode (continued)**

BALL	BALL NAME	PR2_PRU0_PAR_CAP_MANUAL2		CFG REGISTER	MUXMODE
		A_DELAY (ps)	G_DELAY (ps)		12
B18	mcasp3_aclkx	973	0	CFG_MCASP3_ACLKX_IN	pr2_pru0_gpi12
B19	mcasp3_axr0	1996	0	CFG_MCASP3_AXR0_IN	pr2_pru0_gpi14
C17	mcasp3_axr1	2352	0	CFG_MCASP3_AXR1_IN	pr2_pru0_gpi15
F15	mcasp3_fsx	2251	0	CFG_MCASP3_FSX_IN	pr2_pru0_gpi13
AD4	mmc3_clk	4401	1940	CFG_MMC3_CLK_IN	pr2_pru0_gpi2
AC4	mmc3_cmd	4360	1772	CFG_MMC3_CMD_IN	pr2_pru0_gpi3
AC7	mmc3_dat0	4307	1751	CFG_MMC3_DAT0_IN	pr2_pru0_gpi4
AC6	mmc3_dat1	4204	2185	CFG_MMC3_DAT1_IN	pr2_pru0_gpi5
AC9	mmc3_dat2	4311	1810	CFG_MMC3_DAT2_IN	pr2_pru0_gpi6
AC3	mmc3_dat3	4298	2167	CFG_MMC3_DAT3_IN	pr2_pru0_gpi7
AC8	mmc3_dat4	4374	1487	CFG_MMC3_DAT4_IN	pr2_pru0_gpi8
AD6	mmc3_dat5	4295	1926	CFG_MMC3_DAT5_IN	pr2_pru0_gpi9
AB8	mmc3_dat6	4339	1802	CFG_MMC3_DAT6_IN	pr2_pru0_gpi10
AB5	mmc3_dat7	4361	1278	CFG_MMC3_DAT7_IN	pr2_pru0_gpi11

Manual IO Timings Modes must be used to ensure some IO timings for PRU-ICSS2 PRU1 IOSET1 Parallel Capture mode. See [Table 5-33, Modes Summary](#) for a list of IO timings requiring the use of Manual IO Timings Modes. See [Table 5-208, Manual Functions Mapping for PRU-ICSS2 PRU1 IOSET1 Parallel Capture mode](#) for a definition of the Manual modes.

[Table 5-207](#) lists the A\_DELAY and G\_DELAY values needed to calculate the correct values to be set in the CFG\_x registers.

**Table 5-208. Manual Functions Mapping for PRU-ICSS2 PRU1 IOSET1 Parallel Capture mode**

BALL	BALL NAME	PR2_PRU1_PAR_CAP_MANUAL1		CFG REGISTER	MUXMODE
		A_DELAY (ps)	G_DELAY (ps)		12
U3	RMII_MHZ_50_CLK	1814	0	CFG_RMII_MHZ_50_CLK_IN	pr2_pru1_gpi2
U5	rgmii0_rxc	1387	0	CFG_RGMII0_RXC_IN	pr2_pru1_gpi11
V5	rgmii0_rxctl	2154	0	CFG_RGMII0_RXCTL_IN	pr2_pru1_gpi12
W2	rgmii0_rxd0	0	0	CFG_RGMII0_RXD0_IN	pr2_pru1_gpi16
Y2	rgmii0_rxd1	1812	0	CFG_RGMII0_RXD1_IN	pr2_pru1_gpi15
V3	rgmii0_rxd2	1745	0	CFG_RGMII0_RXD2_IN	pr2_pru1_gpi14
V4	rgmii0_rxd3	2092	0	CFG_RGMII0_RXD3_IN	pr2_pru1_gpi13
W9	rgmii0_txc	1423	0	CFG_RGMII0_TXC_IN	pr2_pru1_gpi5
V9	rgmii0_txctl	1433	0	CFG_RGMII0_TXCTL_IN	pr2_pru1_gpi6
U6	rgmii0_txd0	1486	0	CFG_RGMII0_TXD0_IN	pr2_pru1_gpi10
V6	rgmii0_txd1	1950	0	CFG_RGMII0_TXD1_IN	pr2_pru1_gpi9
U7	rgmii0_txd2	1626	0	CFG_RGMII0_TXD2_IN	pr2_pru1_gpi8
V7	rgmii0_txd3	1966	0	CFG_RGMII0_TXD3_IN	pr2_pru1_gpi7
V2	uart3_rxd	1522	0	CFG_UART3_RXD_IN	pr2_pru1_gpi3
Y1	uart3_txd	1204	0	CFG_UART3_TXD_IN	pr2_pru1_gpi4
U4	mdio_d	1792	0	CFG_MDIO_D_IN	pr2_pru1_gpi1
V1	mdio_mclk	1619	0	CFG_MDIO_MCLK_IN	pr2_pru1_gpi0

Manual IO Timings Modes must be used to ensure some IO timings for PRU-ICSS2 PRU1 IOSET2 Parallel Capture mode. See [Table 5-33, Modes Summary](#) for a list of IO timings requiring the use of Manual IO Timings Modes. See [Table 5-209, Manual Functions Mapping for PRU-ICSS2 PRU1 IOSET2 Parallel Capture mode](#) for a definition of the Manual modes.

[Table 5-209](#) lists the A\_DELAY and G\_DELAY values needed to calculate the correct values to be set in the CFG\_x registers.

**Table 5-209. Manual Functions Mapping for PRU-ICSS2 PRU1 IOSET2 Parallel Capture mode**

BALL	BALL NAME	PR2_PRU1_PAR_CAP_MANUAL2		CFG REGISTER	MUXMODE 12
		A_DELAY (ps)	G_DELAY (ps)		
C14	mcasp1_aclkx	2260	0	CFG_MCASP1_ACLKX_IN	pr2_pru1_gpi7
G12	mcasp1_axr0	3213	0	CFG_MCASP1_AXR0_IN	pr2_pru1_gpi8
F12	mcasp1_axr1	2365	0	CFG_MCASP1_AXR1_IN	pr2_pru1_gpi9
B13	mcasp1_axr10	2590	0	CFG_MCASP1_AXR10_IN	pr2_pru1_gpi12
A12	mcasp1_axr11	2933	0	CFG_MCASP1_AXR11_IN	pr2_pru1_gpi13
E14	mcasp1_axr12	2280	0	CFG_MCASP1_AXR12_IN	pr2_pru1_gpi14
A13	mcasp1_axr13	2281	0	CFG_MCASP1_AXR13_IN	pr2_pru1_gpi15
G14	mcasp1_axr14	0	0	CFG_MCASP1_AXR14_IN	pr2_pru1_gpi16
B12	mcasp1_axr8	2663	0	CFG_MCASP1_AXR8_IN	pr2_pru1_gpi10
A11	mcasp1_axr9	2579	0	CFG_MCASP1_AXR9_IN	pr2_pru1_gpi11
D17	mcasp4_axr1	2903	0	CFG_MCASP4_AXR1_IN	pr2_pru1_gpi0
AA3	mcasp5_aclkx	3935	1700	CFG_MCASP5_ACLKX_IN	pr2_pru1_gpi1
AB3	mcasp5_axr0	3929	2308	CFG_MCASP5_AXR0_IN	pr2_pru1_gpi3
AA4	mcasp5_axr1	3931	2345	CFG_MCASP5_AXR1_IN	pr2_pru1_gpi4
AB9	mcasp5_fsx	3900	1877	CFG_MCASP5_FSX_IN	pr2_pru1_gpi2
D18	xref_clk0	930	0	CFG_XREF_CLK0_IN	pr2_pru1_gpi5
E17	xref_clk1	2152	0	CFG_XREF_CLK1_IN	pr2_pru1_gpi6

#### 5.10.6.21 System and Miscellaneous interfaces

The Device includes the following system and miscellaneous interfaces:

- Sysboot Interface
- System DMA Interface
- Interrupt Controllers (INTC) Interface
- Observability Signal (OBS) Interface

#### 5.10.7 Emulation and Debug Subsystem

The Device includes the following test interfaces:

- IEEE 1149.1 Standard-Test-Access Port (JTAG)
- Trace Port Interface Unit (TPIU)
- Advanced Event Triggering Interface (AET)

### 5.10.7.1 JTAG

The JTAG (IEEE Standard 1149.1-1990 Standard-Test-Access Port and Boundary Scan Architecture) interface is used for BSDL testing and emulation of the device. The `trstn` pin only needs to be released when it is necessary to use a JTAG controller to debug the device or exercise the device's boundary scan functionality. For maximum reliability, the device includes an Internal Pulldown (IPD) on the `trstn` pin to ensure that `trstn` is always asserted upon power up and the device's internal emulation logic is always properly initialized. JTAG controllers from Texas Instruments actively drive `trstn` high. However, some third-party JTAG controllers may not drive `trstn` high but expect the use of a pullup resistor on `trstn`. When using this type of JTAG controller, assert `trstn` to initialize the device after powerup and externally drive `trstn` high before attempting any emulation or boundary-scan operations.

The main JTAG features include:

- 32KB Embedded Trace Buffer™ (ETB)
- 5-pin system trace interface for debug
- Supports Advanced Event Triggering (AET)
- All processors can be emulated via JTAG ports
- All functions on EMU pins of the device:
  - EMU[1:0] - cross-triggering, boot mode (WIR), STM trace
  - EMU[4:2] - STM trace only (single direction)

#### 5.10.7.1.1 JTAG Electrical Data/Timing

Table 5-210, Table 5-211, and Figure 5-129 assume testing over the recommended operating conditions and electrical characteristic conditions below.

**Table 5-210. Timing Requirements for IEEE 1149.1 JTAG**

NO.	PARAMETER	DESCRIPTION	MIN	MAX	UNIT
J1	$t_c(\text{TCK})$	Cycle time, TCK	62.29		ns
J1H	$t_w(\text{TCKH})$	Pulse duration, TCK high (40% of $t_c$ )	24.92		ns
J1L	$t_w(\text{TCKL})$	Pulse duration, TCK low (40% of $t_c$ )	24.92		ns
J3	$t_{su}(\text{TDI-TCK})$	Input setup time, TDI valid to TCK high	6.23		ns
	$t_{su}(\text{TMS-TCK})$	Input setup time, TMS valid to TCK high	6.23		ns
J4	$t_h(\text{TCK-TDI})$	Input hold time, TDI valid from TCK high	31.15		ns
	$t_h(\text{TCK-TMS})$	Input hold time, TMS valid from TCK high	31.15		ns

**Table 5-211. Switching Characteristics Over Recommended Operating Conditions for IEEE 1149.1 JTAG**

NO.	PARAMETER	DESCRIPTION	MIN	MAX	UNIT
J2	$t_d(\text{TCKL-TDOV})$	Delay time, TCK low to TDO valid	0	30.5	ns

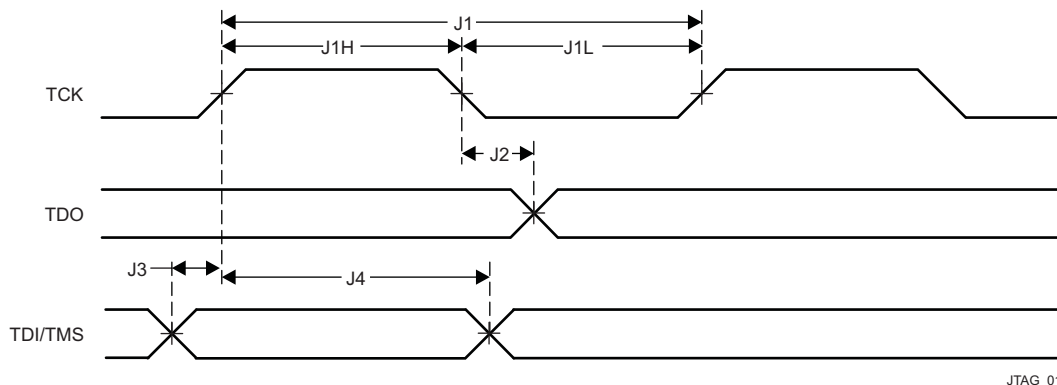

**Figure 5-129. JTAG Timing**

Table 5-212, Table 5-213, and Figure 5-130 assume testing over the recommended operating conditions and electrical characteristic conditions below.

**Table 5-212. Timing Requirements for IEEE 1149.1 JTAG With RTCK**

NO.	PARAMETER	DESCRIPTION	MIN	MAX	UNIT
JR1	$t_c(\text{TCK})$	Cycle time, TCK	62.29		ns
JR1H	$t_w(\text{TCKH})$	Pulse duration, TCK high (40% of $t_c$ )	24.92		ns
JR1L	$t_w(\text{TCKL})$	Pulse duration, TCK low (40% of $t_c$ )	24.92		ns
JR3	$t_{su}(\text{TDI-TCK})$	Input setup time, TDI valid to TCK high	6.23		ns
	$t_{su}(\text{TMS-TCK})$	Input setup time, TMS valid to TCK high	6.23		ns
JR4	$t_h(\text{TCK-TDI})$	Input hold time, TDI valid from TCK high	31.15		ns
	$t_h(\text{TCK-TMS})$	Input hold time, TMS valid from TCK high	31.15		ns

**Table 5-213. Switching Characteristics Over Recommended Operating Conditions for IEEE 1149.1 JTAG With RTCK**

NO.	PARAMETER	DESCRIPTION	MIN	MAX	UNIT
JR5	$t_d(\text{TCK-RTCK})$	Delay time, TCK to RTCK with no selected subpaths (that is, ICEPick is the only tap selected - when the Arm is in the scan chain, the delay time is a function of the Arm functional clock).	0	27	ns
JR6	$t_c(\text{RTCK})$	Cycle time, RTCK	62.29		ns
JR7	$t_w(\text{RTCKH})$	Pulse duration, RTCK high (40% of $t_c$ )	24.92		ns
JR8	$t_w(\text{RTCKL})$	Pulse duration, RTCK low (40% of $t_c$ )	24.92		ns

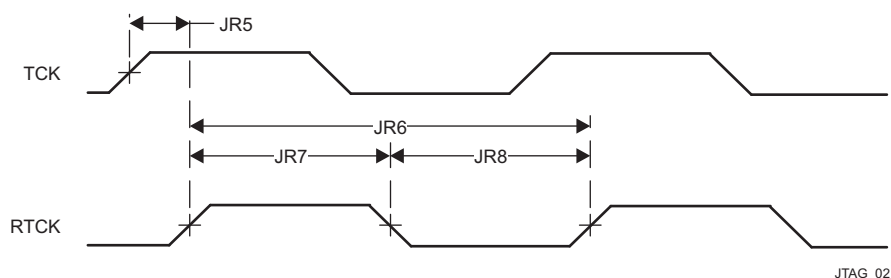

**Figure 5-130. JTAG With RTCK Timing**

### 5.10.7.2 TPIU

#### CAUTION

The I/O timings provided in this section are valid only if signals within a single IOSET are used. The IOSETs are defined in Table 5-215.

#### 5.10.7.2.1 TPIU PLL DDR Mode

Table 5-214 and Figure 5-131 assume testing over the recommended operating conditions and electrical characteristic conditions below.

**Table 5-214. Switching Characteristics for TPIU**

NO.	PARAMETER	DESCRIPTION	MIN	MAX	UNIT
TPIU1	$t_c(\text{clk})$	Cycle time, TRACECLK period	5.56		ns
TPIU4	$t_d(\text{clk-cltV})$	Skew time, TRACECLK transition to TRACECTL transition	-0.96	0.96	ns
TPIU5	$t_d(\text{clk-dataV})$	Skew time, TRACECLK transition to TRACEDATA[17:0]	-0.96	0.96	ns



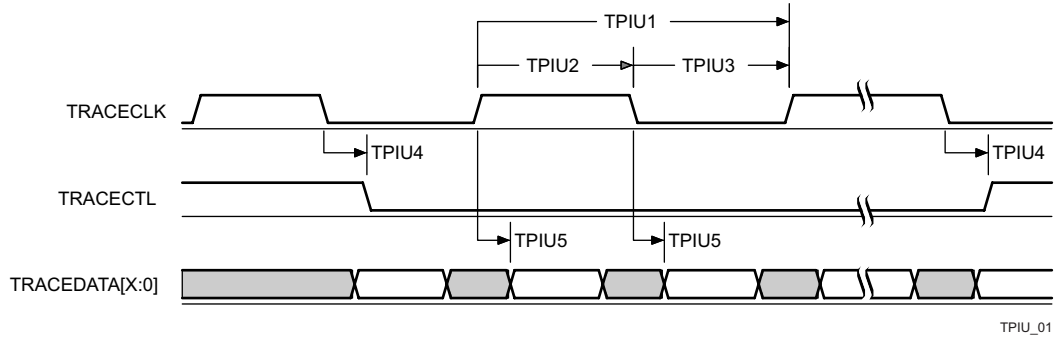

Figure 5-131. TPIU—PLL DDR Transmit Mode<sup>(1)</sup>

(1) In d[X:0], X is equal to 15 or 17.

In Table 5-215 are presented the specific groupings of signals (IOSET) for use with TPIU signals.

Table 5-215. TPIU IOSETs

SIGNALS	IOSET1		IOSET2	
	BALL	MUX	BALL	MUX
emu0	G21	0	G21	0
emu1	D24	0	D24	0
emu2	F10	2	F10	2
emu3	D7	2	D7	2
emu4	A7	2	A7	2
emu5	E1	5	G11	2
emu6	G2	5	E9	2
emu7	H7	5	F9	2
emu8	G1	5	F8	2
emu9	G6	5	E7	2
emu10	F2	5	D8	2
emu11	F3	5	A5	2
emu12	D1	5	C6	2
emu13	E2	5	C8	2
emu14	D2	5	C7	2
emu15	F4	5	A8	2
emu16	C1	5	C9	2
emu17	E4	5	A9	2
emu18	F5	5	B9	2
emu19	E6	5	A10	2

## 6 Detailed Description

### 6.1 Overview

AM574x Sitara Arm applications processors are built to meet the intense processing needs of modern embedded products.

AM574x devices bring high processing performance through the maximum flexibility of a fully integrated mixed processor solution. The devices also combine programmable video processing with a highly integrated peripheral set. Cryptographic acceleration is available in every AM574x device.

Programmability is provided by dual-core Arm Cortex-A15 RISC CPUs with Arm® Neon™ extension, and two TI C66x VLIW floating-point DSP cores. The Arm allows developers to keep control functions separate from other algorithms programmed on the DSPs and coprocessors, thus reducing the complexity of the system software.

Additionally, TI provides a complete set of development tools for the Arm and C66x DSP, including C compilers, a DSP assembly optimizer to simplify programming and scheduling, and a debugging interface for visibility into source code execution.

Cryptographic acceleration is available in all devices. All other supported security features, including support for secure boot, debug security and support for trusted execution environment are available on High-Security (HS) devices. For more information about HS devices, contact your TI representative.

### 6.2 Processor Subsystems

#### 6.2.1 MPU

The dual Cortex®-A15 microprocessor unit (MPU) subsystem serves the applications processing role by running the high-level operating system (HLOS) and application code.

The MPU subsystem incorporates two Cortex-A15 MPU cores (MPU\_C0 and MPU\_C1), individual level 1 (L1) caches, level 2 (L2) cache (MPU\_L2CACHE) shared between them, and various other shared peripherals. To aid software development, the processor cores can be kept cache-coherent with each other and with the L2 cache.

The MPU subsystem provides a high-performance computing platform with high peak-computing performance and low memory latency.

The MPU subsystem integrates the following:

- Arm Cortex-A15 MP Core (MPU\_CLUSTER)
  - Two Cortex-A15 MPU cores (revision r2p2, SMP architecture), each of them having the following features:
    - Superscalar, dynamic multi-issue technology
      - Out-of-order (OoO) instruction dispatch and completion
      - Dynamic branch prediction with branch target buffer (BTB), global history buffer (GHB), and 48-entry return stack
      - Continuous fetch and decoding of three instructions per clock cycle
      - Dispatch of up to four instructions and completion of eight instructions per clock cycle
      - Provides optimal performance from binaries compiled for previous Arm processors
      - Five execution units handle simple instructions, branch instructions, Arm® Neon™ and floating point instructions, multiply instructions, and load and store instructions.
      - Simple instructions take two cycles from dispatch, while complex instructions take up to 11 cycles.
      - Can issue two simple instructions in a cycle
      - Can issue a load and a store instruction in the same cycle
    - Integrated Arm® Neon™ processing engine to include the Arm® Neon™ Advanced SIMD (single instruction, multiple data) support for accelerated media and signal processing computation
    - Includes VFPv4-compatible hardware to support single- and double-precision add, subtract, divide, multiply and accumulate, and square root operations
    - Extensive support to accelerate virtualization using a hypervisor
    - 32-KiB L1 instruction (L1I) and 32-KiB L1 data (L1D) cache:
      - 64-byte line size
      - 2-way set associative
    - Memory management unit (MMU):
      - Two-level translation lookaside buffer (TLB) organization
        - First level is an 32-entry, fully associative micro-TLB implemented for each of instruction fetch, load, and store.
        - Second level is a unified, 4-way associative, 512-entry main TLB
      - Supports hardware TLB table-walk for backward-compatible and new 64-bit entry page table formats
      - New page table format can produce 40-bit physical addresses
      - Two-stage translation where first stage is HLOS-controlled and the second level may be controlled by a hypervisor. Second stage always uses the new page table format
  - Integrated L2 cache (MPU\_L2CACHE) and snoop control unit (SCU):
    - 2-MiB of unified (instructions and data) cache organized as 16 ways of 2048 sets of 64-byte lines
    - Redundant L1 data (cache) tags to perform snoop filtering (L1 instruction cache tags are not duplicated)
    - Operates at Cortex-A15 MPU core clock rate
    - Integrated L2 cache controller (MPU\_L2CACHE\_CTRL):
      - Sixteen 64-byte line buffers that handle evictions, line fills and snoop transfers
      - One 128-bit AMBA4 Coherent Bus (AXI4-ACE) port
      - Auto-prefetch buffer for up to 16 streams per core and detecting forward and backward strides
  - Generalized interrupt controller (GIC, also referred to as MPU\_INTC): An interrupt controller supplied by Arm. The single GIC in the MPU\_CLUSTER routes interrupts to each of the MPU cores. The GIC supports:

- Number of shared peripheral interrupts (SPI): 160
- Number of software generated interrupts (SGI): 16
- Number of CPU interfaces: 2
- Virtual CPU interface for virtualization support. This allows the majority of guest operating system (OS) interactions with the GIC to be handled in hardware, but with physical interrupts still requiring hypervisor intervention to assign them to the appropriate virtual machine.
- Integrated timer counter and one timer block per MPU core
- Arm® CoreSight™ debug and trace modules. For more information, see *On-Chip Debug Support* chapter in the device TRM.
- MPU\_AXI2OCP bridge (local interconnect):
  - Connected to Memory Adapter (MPU\_MA), which routes the non-EMIF address space transactions to MPU\_AXI2OCP
  - Single request multiple data (SRMD) protocol on L3\_MAIN port
  - Multiple targets:
    - 64-bit port to the L3\_MAIN interconnect. Interface frequency is 1/4 or 1/8 of core frequency
    - MPU\_ROM
    - Internal MPU subsystem peripheral targets, including Memory Adapter LISA Section Manager (MA\_LSM), wake-up generator (MPU\_WUGEN), watchdog timer (MPU\_WD\_TIMER), and local PRCM module (MPU\_PRCM) configuration
    - Internal AXI target, Arm® CoreSight™ System Trace Module (CS\_STM)
- Memory adapter (MPU\_MA): Helps decrease the latency of accesses between the MPU\_L2CACHE and the two EMIFs (EMIF0 and EMIF1) by providing a direct path between the MPU subsystem and the EMIFs:
  - Connected to 128-bit AMBA4 interface of MPU\_CLUSTER
  - Direct 128-bit interface to each of EMIF0 and EMIF1
  - Interface speed between MPU\_CLUSTER and MPU\_MA is at half-speed of MPU\_CLUSTER internal core frequency
  - Quarter-speed interface to EMIF
  - Uses firewall logic to check access rights of incoming addresses
- Local PRCM (MPU\_PRCM):
  - Handles MPU\_C0 and MPU\_C1 power domains
  - Supports SR3-APG (SmartReflex3 Automatic Power Gating) power management technology inside the MPU\_CLUSTER
  - MPU subsystem has six power domains
- Wake-up generator (MPU\_WUGEN)
  - Responsible for waking up the MPU cores
- Standby controller: Handles the power transitions inside the MPU subsystem
- Realtime (master) counter (COUNTER\_REALTIME): Produces the count used by the private timer peripherals in the MPU\_CLUSTER
- Watchdog timer (MPU\_WD\_TIMER): Used to generate a chip-level watchdog reset request to global PRCM
- On-chip boot ROM (MPU\_ROM): The MPU\_ROM size is 48-KiB, and the address range is from 0x4003 8000 to 0x4004 3FFF. For more information about booting from this memory, see *Initialization* chapter in the device TRM.

- Interfaces:
  - 128-bit interface to each of EMIF0 and EMIF1
  - 64-bit master port to the L3\_MAIN interconnect
  - 32-bit slave port from the L4\_CFG\_EMU interconnect (debug subsystem) for configuration of the MPU subsystem debug modules
  - 32-bit slave port from the L4\_CFG interconnect for memory adapter firewall (MPU\_MA\_NTTP\_FW) configuration
  - 32-bit ATB output for transmitting debug and trace data
  - 160 peripheral interrupt inputs

For more information, see *Dual Cortex-A15 MPU Subsystem* chapter in the device TRM.

## 6.2.2 DSP Subsystem

The device includes two identical instances (DSP1 and DSP2) of a digital signal processor (DSP) subsystem, based on the TI's standard TMS320C66x DSP CorePac core.

The TMS320C66x DSP core enhances the TMS320C674x core, which merges the C674x floating point and the C64x+ fixed-point instruction set architectures. The C66x DSP is object-code compatible with the C64x+/C674x DSPs.

For more information on the TMS320C66x core CPU, see the [TMS320C66x DSP CPU and Instruction Set Reference Guide](#).

The DSP subsystem integrated in the device includes the following components:

- A TMS320C66x CorePac DSP core that encompasses:
  - L1 program-dedicated (L1P) cacheable memory
  - L1 data-dedicated (L1D) cacheable memory
  - L2 (program and data) cacheable memory
  - Extended Memory Controller (XMC)
  - External Memory Controller (EMC)
  - DSP CorePac located interrupt controller (INTC)
  - DSP CorePac located power-down controller (PDC)
- Dedicated enhanced data memory access engine - EDMA, to transfer data from/to memories and peripherals external to the DSP subsystems and to local DSP memory (most commonly L2 SRAM). The external DMA requests are passed through DSP system level (SYS) wakeup logic, and collected from the DSP1 / DSP2 dedicated outputs of the device DMA Events Crossbar for each of the two subsystems.
- A level 2 (L2) interconnect network (DSP NoC) to allow connectivity between different modules of the subsystem or the remainder of the device via the device L3\_MAIN interconnect.
- Two memory management units (on EDMA L2 interconnect and DSP MDMA paths) for accessing the device L3\_MAIN interconnect address space
- Dedicated system control logic (DSP\_SYSTEM) responsible for power management, clock generation, and connection to the device power, reset, and clock management (PRCM) module

The TMS320C66x Instruction Set Architecture (ISA) is the latest for the C6000 family. As with its predecessors (C64x, C64x+ and C674x), the C66x is an advanced VLIW architecture with 8 functional units (two multiplier units and six arithmetic logic units) that operate in parallel. The C66x CPU has a total of 64 general-purpose 32-bit registers.

Some features of the DSP C6000 family devices are:

- Advanced VLIW CPU with eight functional units (two multipliers and six ALUs) which:
  - Executes up to eight instructions per cycle for up to ten times the performance of typical DSPs
  - Allows designers to develop highly effective RISC-like code for fast development time

- Instruction packing
  - Gives code size equivalence for eight instructions executed serially or in parallel
  - Reduces code size, program fetches, and power consumption
- Conditional execution of most instructions
  - Reduces costly branching
  - Increases parallelism for higher sustained performance
- Efficient code execution on independent functional units
  - Industry's most efficient C compiler on DSP benchmark suite
  - Industry's first assembly optimizer for fast development and improved parallelization
- 8-/16-/32-/64-bit data support, providing efficient memory support for a variety of applications
- 40-bit arithmetic options which add extra precision for vocoders and other computationally intensive applications
- Saturation and normalization to provide support for key arithmetic operations
- Field manipulation and instruction extract, set, clear, and bit counting support common operation found in control and data manipulation applications.

The C66x CPU has the following additional features:

- Each multiplier can perform two  $16 \times 16$ -bit or four  $8 \times 8$  bit multiplies every clock cycle.
- Quad 8-bit and dual 16-bit instruction set extensions with data flow support
- Support for non-aligned 32-bit (word) and 64-bit (double word) memory accesses
- Special communication-specific instructions have been added to address common operations in error-correcting codes.
- Bit count and rotate hardware extends support for bit-level algorithms.
- Compact instructions: Common instructions (AND, ADD, LD, MPY) have 16-bit versions to reduce code size.
- Protected mode operation: A two-level system of privileged program execution to support higher-capability operating systems and system features such as memory protection.
- Exceptions support for error detection and program redirection to provide robust code execution
- Hardware support for modulo loop operation to reduce code size and allow interrupts during fully-pipelined code
- Each multiplier can perform  $32 \times 32$  bit multiplies
- Additional instructions to support complex multiplies allowing up to eight 16-bit multiply/add/subtracts per clock cycle

The TMS320C66x has the following key improvements to the ISA:

- 4x Multiply Accumulate improvement for both fixed and floating point
- Improvement of the floating point arithmetic
- Enhancement of the vector processing capability for fixed and floating point
- Addition of domain-specific instructions for complex arithmetic and matrix operations

**On the C66x ISA, the vector processing capability is improved by extending the width of the SIMD instructions.** The C674x DSP supports 2-way SIMD operations for 16-bit data and 4-way SIMD operations for 8-bit data. C66x enhances this capabilities with the addition of SIMD instructions for 32-bit data allowing operation on 128-bit vectors. For example the QMPY32 instruction is able to perform the element to element multiplication between two vectors of four 32-bit data each.

C66x ISA includes a set of specific instructions to handle complex arithmetic and matrix operations.

- **TMS320C66x DSP CorePac memory components:**
  - A 32-KiB L1 program memory (L1P) configurable as cache and/or SRAM:
    - When configured as a cache, the L1P is a 1-way set-associative cache with a 32-byte cache line
    - The DSP CorePac L1P memory controller provides bandwidth management, memory protection, and power-down functions
    - The L1P is capable of cache block and global coherence operations
    - The L1P controller has an Error Detection (ED) mechanism, including necessary SRAM
    - The L1P memory can be fully configured as a cache or SRAM
    - Page size for L1P memory is 2KB
  - A 32-KiB L1 data memory (L1D) with ECC, configurable as cache and / or SRAM:
    - When configured as a cache, the L1D is a 2-way set-associative cache with a 64-byte cache line
    - The DSP CorePac L1D memory controller provides bandwidth management, memory protection, and power-down functions
    - The L1D memory can be fully configured as a cache or SRAM
    - No support for error correction or detection
    - Page size for L1D memory is 2KB
  - A 288-KiB (program and data) L2 memory, only part of which is cacheable:
    - When configured as a cache, the L2 memory is a 4-way set associative cache with a 128-byte cache line
    - Only 256 KiB of L2 memory can be configured as cache or SRAM
    - 32 KiB of the L2 memory is always mapped as SRAM
    - The L2 memory controller has an Error Correction Code (ECC) and ED mechanism, including necessary SRAM
    - The L2 memory controller supports hardware prefetching and also provides bandwidth management, memory protection, and power-down functions.
    - Page size for L2 memory is 16KB
- The **External Memory Controller (EMC)** is a bridge from the C66x CorePac to the rest of the DSP subsystem and device. It has:
  - a 32-bit Configuration port (CFG) providing access to local subsystem resources (like DSP\_EDMA, DSP\_SYSTEM, and so forth) or to L3\_MAIN resources accessible via the CFG address range.
  - a 128-bit slave DMA port which provides accesses of system masters outside the DSP subsystem to resources inside the DSP subsystem or C66x DSP CorePac memories, that is, when the DSP subsystem is the slave in a transaction.
- The **Extended Memory Controller (XMC)** processes requests from the L2 Cache Controller (which are a result of CPU instruction fetches, load/store commands, cache operations) to device resources via the C66x DSP CorePac 128-bit Master DMA (MDMA) port:
  - Memory protection for addresses outside C66x DSP CorePac generated over device L3\_MAIN on the MDMA port
  - Prefetch, multi-in-flight requests
- A DSP local **Interrupt Controller (INTC)** in the DSP C66x CorePac, interfaces the system events to the DSP C66x core CPU interrupt and exceptions inputs. Each DSP subsystem C66x CorePac interrupt controller supports up to 128 system events of which 64 interrupts are external to DSP subsystems, collected from the DSP1 /DSP2 dedicated outputs of the device Interrupt Crossbar.

- **Local Enhanced Direct Memory Access (EDMA) controller features:**
  - Channel controller (CC): 64-channel, 128 PaRAM, 2 Queues
  - 2 x Third-party Transfer Controllers (TPTC0 and TPTC1):
    - Each TC has a 128-bit read port and a 128-bit write port
    - 2KiB FIFOs on each TPTC
  - 1-dimensional/2-dimensional (1D/2D) addressing
  - Chaining capability
- **DSP subsystem integrated MMUs:**
  - Two MMUs are integrated:
    - The MMU0 is located between DSP MDMA master port and the device L3\_MAIN interconnect and can be optionally bypassed
    - The MMU1 is located between the EDMA master port and the device L3\_MAIN interconnect
- A DSP local **Power-Down Controller (PDC)** is responsible to power-down various parts of the DSP C66x CorePac, or the entire DSP C66x CorePac.
- The DSP subsystem **System Control logic** provides:
  - Slave idle and master standby protocols with device PRCM for powerdown
  - OCP Disconnect handshake for init and target busses
  - Asynchronous reset
  - Power-down modes:
    - "Clockstop" mode featuring wake-up on interrupt event. The DMA event wake-up is managed in software.
- The device DSP subsystems are supplied by a PRCM DPLL, but each DSP1/2 **has integrated its own PLL module** outside the C66x CorePac for clock gating and division.
- **The device DSP subsystem has following port instances** to connect to remaining part of the device. See also:
  - A 128-bit initiator (DSP MDMA master) port for MDMA/Cache requests
  - A 128-bit initiator (DSP EDMA master) port for EDMA requests
  - A 32-bit initiator (DSP CFG master) port for configuration requests
  - A 128-bit target (DSP slave) port for requests to DSP memories and various peripherals
- **C66x DSP subsystem (DSPSS) safety aspects:**
  - Above mentioned memory ECC/ED mechanisms
  - MMUs enable mapping of only the necessary application space to the processor
  - Memory Protection Units internal to the DSPSS (in L1P, L1D and L2 memory controllers) and external to DSPSS (firewalls) to help define legal accesses and raise exceptions on illegal accesses
  - Exceptions: Memory errors, various DSP errors, MMU errors and some system errors are detected and cause exceptions. The exceptions could be handled by the DSP or by a designated safety processor at the chip level. Note that it may not be possible for the safety processor to completely handle some exceptions

#### Unsupported features on the C66x DSP core for the device are:

- The Extended Memory Controller MPAX (memory protection and address extension) 36-bit addressing is NOT supported

#### Known DSP subsystem powermode restrictions for the device are:

- "Full logic / RAM retention" mode featuring wake-up on both interrupt or DMA event (logic in "always on" domain). Only OFF mode is supported by DSP subsystem, **requiring full boot.**

For more information about C66x debug/trace support, see *On-Chip Debug Support* chapter in the device TRM.



### 6.2.3 IPU

Each IPU subsystem contains two Arm® Cortex-M4 processors (IPUx\_C0 and IPUx\_C1) that share a common level 1 (L1) cache (called unicache [IPUx\_UNICACHE]). The two Cortex-M4 cores are completely homogeneous to one another. Any task possible using one Cortex-M4 core is also possible using the other Cortex-M4 core. It is software responsibility to distribute the various tasks between each Cortex-M4 core for optimal performance.

The key features of the IPU subsystem are:

- Two Arm Cortex-M4 microprocessors (IPUx\_C0 and IPUx\_C1):
  - Armv7-M and Thumb®-2 instruction set architecture (ISA)
  - Armv6 SIMD and digital signal processor (DSP) extensions
  - Single-cycle MAC
  - Integrated nested vector interrupt controller (NVIC) (also called IPUx\_Cx\_INTC, where x = 0, 1)
  - Integrated bus matrix
  - Registers:
    - Thirteen general-purpose 32-bit registers
    - Link register (LR)
    - Program counter (PC)
    - Program status register, xPSR
    - Two banked SP registers
  - Integrated power management
  - Extensive debug capabilities
- Unicache interface:
  - Instruction and data interface
  - Supports paralleled accesses
- Level 2 (L2) master interface (MIF) splitter for access to memory or configuration port
- Configuration port: Used for unicache maintenance and unicache memory management unit (IPUx\_UNICACHE\_MMU) configuration
- Unicache:
  - 32 KiB divided into 16 banks
  - 4-way
  - Cache configuration lock/freeze/preload
  - Internal MMU:
    - 16-entry region-based address translation
    - Read/write control and access type control
    - Execute Never (XN) MMU protection policy
    - Little-endian format
- Subsystem counter timer module (IPUx\_UNICACHE\_SCTM, or just SCTM)
- On-chip ROM (IPUx\_ROM) and banked RAM (IPUx\_RAM) memory
- Emulation/debug: Emulation feature embedded in Cortex-M4
- L2 MMU (IPUx\_MMU): 32 entries with table walking logic
- Wake-up generator (IPUx\_WUGEN): Generates wake-up request from external interrupts
- Power management:
  - Local power-management control: Configurable through the IPUx\_WUGEN registers.
  - Three sleep modes supported, controlled by the local power-management module.
  - IPUx is clock-gated in all sleep modes.
  - IPUx\_Cx\_INTC interrupt interface stays awake.

For more information, see *Dual Cortex-M4 IPU Subsystem* chapter in the device TRM.

## 6.2.4 Interrupt Controller

The device has a large number of interrupts to service the needs of its many peripherals and subsystems. The MPU, DSP (x2), IPU (x2), and PRU-ICSS (x2) subsystems are capable of servicing these interrupts via their integrated interrupt controllers. In addition, each processor's interrupt controller is preceded by an Interrupt Controller Crossbar (IRQ\_CROSSBAR) that provides flexibility in mapping the device interrupts to processor interrupt inputs. For more information about IRQ crossbar, see *Control Module* chapter in the device TRM.

### Dual Cortex®-A15 MPU Subsystem Interrupt Controller (MPU\_INTC)

The MPU\_INTC module (also called Generalized Interrupt Controller [GIC]) is a single functional unit that is integrated in the Arm® Cortex-A15 multiprocessor core (MPCore) alongside Cortex-A15 processors. It provides:

- 160 hardware interrupt inputs
- Generation of interrupts by software
- Prioritization of interrupts
- Masking of any interrupts
- Distribution of the interrupts to the target Cortex-A15 processor(s)
- Tracking the status of interrupts

Each Cortex-A15 processor supports three main groups of interrupt sources, with each interrupt source having a unique ID:

- *Software Generated Interrupts (SGIs)*: SGIs are generated by writing to the Cortex-A15 Software Generated Interrupt Register (GICD\_SGIR). A maximum of 16 SGIs (ID0–ID15) can be generated for each CPU interface. An SGI has edge-triggered properties. The software triggering of the interrupt is equivalent to the edge transition of the interrupt signal on a peripheral input.
- *Private Peripheral Interrupts (PPIs)*: A PPI is an interrupt generated by a peripheral that is specific to a single processor. Although interrupts ID16–ID31 are dedicated to PPIs in general, only seven PPIs are actually used for each CPU interface (ID25–ID31). Interrupts ID16–ID24 are reserved (not used).
- *Shared Peripheral Interrupts (SPIs)*: SPIs are triggered by events generated on associated interrupt input lines. In this device, the GIC is configured to support 160 SPIs corresponding to its external IRQS[159:0] signals.

For detailed information about this module and description of SGIs and PPIs, see the Arm *Cortex-A15 MP Core Technical Reference Manual* (available at [infocenter.arm.com/help/index.jsp](http://infocenter.arm.com/help/index.jsp)).

### C66x DSP Subsystem Interrupt Controller (DSPx\_INTC, where x = 1, 2)

There are two Digital Signal Processing (DSP) subsystems in the device - DSP1, and DSP2. Each DSP subsystem integrates an interrupt controller - DSPx\_INTC, which interfaces the system events to the C66x core interrupt and exceptions inputs. It combines up to 128 interrupts into 12 prioritized interrupts presented to the C66x CPU.

For detailed information about this module, see chapter *DSP Subsystems* in the device TRM.

### Dual Cortex-M4 IPU Subsystem Interrupt Controller (IPUx\_Cx\_INTC, where x = 1, 2)

There are two Image Processing Unit (IPU) subsystems in the device - IPU1, and IPU2. Each IPU subsystem integrates two Arm Cortex-M4 cores.

A Nested Vectored Interrupt Controller (NVIC) is integrated within each Cortex-M4. The interrupt mapping is the same (per IPU) for the two cores to facilitate parallel processing. The NVIC supports:

- 64 external interrupts (in addition to 16 Cortex-M4 internal interrupts), which are dynamically prioritized with 16 levels of priority defined for each core
- Low-latency exception and interrupt handling
- Prioritization and handling of exceptions

- Control of the local power management
- Debug accesses to the processor core

For detailed information about this module, refer to Arm *Cortex-M4 Technical Reference Manual* (available at [infocenter.arm.com/help/index.jsp](http://infocenter.arm.com/help/index.jsp)).

### 6.2.5 VPE

VPE Features:

- Supports memory to memory operations only.
- VPE consist of a single memory to memory path which can perform the following operations:
  - Read of raster or tiled YUV420 coplanar, YUV422 coplanar or YUV422 interleaved video
  - Deinterlacing of the input video using a 4 field motion based algorithm
  - Scaling of the input video up to 1080p (1920x1080) resolution
  - Write of the resulting video in YUV420 coplanar (raster or tiled), YUV422 coplanar (raster or tiled), YUV422 interleaved (raster or tiled), YUV444 single plane (raster only) or RGB888 (raster only)
  - Deinterlacing up to two 1080i video sources.
  - The single data path performs operations in the following order
    - Chroma Upsampling from 420 to 422 (if needed)
    - Deinterlacing of 422 video from interlaced to progressive (if needed)
    - Scaling of 422 video after deinterlace
    - Conversion of 422 video to 420, 444 or RGB (if needed)
  - VC-1 Range Mapping and Range Reduction support on input video before Chroma Upsampling (if needed)
- Chroma Upsampling Features
  - 4 line Catmull-Rom based implementation
  - Programmable coefficients for interlaced or progressive conversion. Separate coefficients can be provided for top and bottom fields

- Deinterlacer Features
  - 8-bit, YCbCr 4:2:2
  - Motion-adaptive deinterlacing (MDT)
    - Motion detection is based on Luma only
    - 4-field data is used
    - Motion values adaptive to the frequency of luma texture
  - Edge-Directed Interpolation (EDI)
    - Edge detection using luma pixels in a 2x7 window
    - Seven edge vectors: -1.5, -1, -0.5, 0, 0.5, 1, 1.5
    - Edge-directed chroma interpolation
    - Soft-switch between edge directed interpolation and vertical interpolation depending on the confidence factor
  - Film Mode Detection (FMD)
    - 3-2 pull down detection
    - 2-2 pull down detection
    - Hysteresis controls how fast FMD can enter/exit film mode (software function)
    - Bad Edit Detection (BED)
  - Progressive Input
    - For Progressive Input, the module passes input to output. No internal processing is performed. This is essentially a bypass mode
  - Interlace Bypass
    - For Interlace Input, the module can pass the inputs data directly to the outputs in a bypass configuration. No internal processing is performed
- Scaler Features
  - Vertical and horizontal up/down scaling
    - Polyphase filter upscaling
  - Running average vertical down scaling for memory optimization
  - Decimation and polyphase filtering for horizontal scaling
  - Non-linear scaling for stretched/compressed left and right sides
  - Input image trimmer for pan/scan support
  - Pre-scaling peaking filter for enhanced sharpness
  - Scale field as frame
  - Interlacing of scaled output
  - Full 1080p input and output support
  - YCbCr422 input and output
  - Minimum horizontal scaling ratio = 1/8x
  - Maximum horizontal scaling ratio – limited by output line buffer (2014 pixels)
  - Scaling filter Coefficient memory download
- Chroma Downsampler Features
  - Simple two-line averager capable of converting from YUV422 to YUV420 space
- 422 to 444 Features
  - Catmull-Rom based filter
  - 4 pixel, fixed coefficient
- Color Space Converter Features
  - Fully programmable 3x3 matrix multiplier with offset control

For more information, see *Video Processing Engine* chapter in the device TRM.

## 6.3 Accelerators and Coprocessors

### 6.3.1 IVA

The IVA supports resolutions up to 1080 p/i with full performance of 60 fps (or 120 fields), achievable for encode or decode only (not for simultaneous encode and decode).

The IVA subsystem is composed of:

- A primary sequencer, including its memories and an imaging controller: ICONT1
- A video direct memory access (VDMA) processor, which can be used as a secondary sequencer: ICONT2
- A VDMA engine: DMA\_IVA
- An entropy codec: ECD3
- A motion compensation engine: MC3
- A transform and quantization calculation engine: CALC3
- A loop filter acceleration engine: ILF3
- A motion estimation acceleration engine: IME3
- An intraprediction estimation engine: IPE3
- Shared level 2 (L2) interface and memory
- Local interconnect (L4\_IVA)
- A message interface for communication between SYNCBOXes
- Mailbox
- A debug module for trace event and software instrumentation: SMSET

For more information, see *IVA Subsystem* chapter in the device TRM.

### 6.3.2 GPU

The 3D graphics processing unit (GPU) accelerates 2-dimensional (2D) and 3-dimensional (3D) graphics and compute applications. It is based on the POWERVR® SGX544-MP2 core from Imagination Technologies. The SGX544-MP2 core is a multicore (dual-core) evolution of the POWERVR SGX544 GPU.

SGX is a new generation of programmable POWERVR graphics and video IP cores. The POWERVR SGX is a scalable architecture which efficiently processes a number of differing multimedia data types concurrently:

- Pixel Data
- Vertex Data
- General Purpose Processing

The dual core GPU splits geometry and pixel rendering among the cores to improve performance proportional to the number of cores.

GPU Features:

- Multicore GPU architecture:
  - 2 × SGX544 cores
  - Shared system level cache of 128 KiB (64 KiB per SGX-544 core)
- Tile-based deferred rendering architecture:
  - Reduces external bandwidth to SDRAM
- Universal Scalable Shader Engine ( USSE™ ):
  - Multithreaded engine incorporating vertex and pixel shader functionality
  - Automatic load balancing of vertex and pixel processing tasks

- Present and texture load accelerator (PTLA):
  - Enables to move, rotate, twiddle, and scale texture surfaces
  - Supports RGB, ARGB, YUV4:2:2, and YUV4:2:0 surface formats
  - Supports bilinear upscale
  - Supports source color key
- Fully virtualized memory addressing for operating system (OS) in a unified memory architecture:
  - Memory management unit (MMU)
  - Up to 4-GiB virtual address space

For more information, see *3D Graphics Accelerator* chapter in the device TRM.

### 6.3.3 PRU-ICSS

The device Programmable Real-Time Unit and Industrial Communication Subsystem (PRU-ICSS) consists of dual 32-bit Load / Store RISC CPU cores - Programmable Real-Time Units (PRU0 and PRU1), shared, data, and instruction memories, internal peripheral modules, and an interrupt controller (PRU-ICSS\_INTC). The programmable nature of the PRUs, along with their access to pins, events and all SoC resources, provides flexibility in implementing fast real-time responses, specialized data handling operations, customer peripheral interfaces, and in off-loading tasks from the other processor cores of the system-on-chip (SoC).

The each PRU-ICSS includes the following main features:

- 21x Enhanced GPIs (EGPIs) and 21x Enhanced GPOs (EGPOs) with asynchronous capture and serial support per each PRU CPU core
- One Ethernet MII\_RT module (PRU-ICSS\_MII\_RT) with two MII ports and configurable connections to PRUs
- 1 MDIO Port (PRU-ICSS\_MII\_MDIO)
- One Industrial Ethernet Peripheral (IEP) to manage/generate Industrial Ethernet functions
- 1 x 16550-compatible UART with a dedicated 192 MHz clock to support 12Mbps Profibus
- 1 Industrial Ethernet timer with 7/9 capture and 8 compare events
- 1 Enhanced Capture Module (ECAP)
- 1 Interrupt Controller (PRU-ICSS\_INTC)
- A flexible power management support
- Integrated switched central resource with programmable priority
- Parity control supported by all memories

For more information, see *Programmable Real-Time Unit Subsystem and Industrial Communication Subsystem* chapter in the device TRM.

### 6.3.4 EVE

The Embedded Vision Engine (EVE) module is a programmable imaging and vision processing engine. Software support for the EVE module is available through OpenCL Custom Device model with fixed set of functions.

## 6.4 Other Subsystems

### 6.4.1 Memory Subsystem

#### 6.4.1.1 EMIF

The EMIF module provides connectivity between DDR memory types and manages data bus read/write accesses between external memory and device subsystems which have master access to the L3\_MAIN interconnect and DMA capability.

The EMIF module has the following capabilities:

- Supports JEDEC standard-compliant DDR3/DDR3L-SDRAM memory types
- 2-GiB SDRAM address range over one chip-select. This range is configurable through the dynamic memory manager (DMM) module
- Supports SDRAM devices with one, two, four or eight internal banks
- Supports SDRAM devices with single or dual die packages
- Data bus widths:
  - 128-bit L3\_MAIN (system) interconnect data bus width
  - 128-bit port for direct connection with MPU subsystem
  - 32-bit SDRAM data bus width
  - 16-bit SDRAM data bus width used in narrow mode
- Supported CAS latencies:
  - DDR3: 5, 6, 7, 8, 9, 10 and 11
- Supports 256-, 512-, 1024-, and 2048-word page sizes
- Supported burst length: 8
- Supports sequential burst type
- SDRAM auto initialization from reset or configuration change
- Supports self refresh and power-down modes for low power
- Partial array self-refresh mode for low power.
- Output impedance (ZQ) calibration for DDR3
- Supports on-die termination (ODT) DDR3
- Supports prioritized refresh
- Programmable SDRAM refresh rate and backlog counter
- Programmable SDRAM timing parameters
- Write and read leveling/calibration and data eye training for DDR3

The EMIF module does not support:

- Burst chop for DDR3
- Interleave burst type
- Auto precharge because of better Bank Interleaving performance
- DLL disabling from EMIF side
- SDRAM devices with more than one die, or topologies which require more than one chip select on a single EMIF channel

For more information, see *EMIF Controller* section in the device TRM.

#### 6.4.1.2 GPMC

The General-Purpose Memory Controller (GPMC) is an external memory controller of the device. Its data access engine provides a flexible programming model for communication with all standard memories.

The GPMC supports the following various access types:

- Asynchronous read/write access
- Asynchronous read page access (4, 8, and 16 Word16)
- Synchronous read/write access
- Synchronous read/write burst access without wrap capability (4, 8 and 16 Word16)
- Synchronous read/write burst access with wrap capability (4, 8 and 16 Word16)
- Address-data-multiplexed (AD) access
- Address-address-data (AAD) multiplexed access
- Little- and big-endian access

The GPMC can communicate with a wide range of external devices:

- External asynchronous or synchronous 8-bit wide memory or device (non burst device)
- External asynchronous or synchronous 16-bit wide memory or device
- External 16-bit non-multiplexed NOR flash device
- External 16-bit address and data multiplexed NOR Flash device
- External 8-bit and 16-bit NAND flash device
- External 16-bit pseudo-SRAM (pSRAM) device

The main features of the GPMC are:

- 8- or 16-bit-wide data path to external memory device
- Supports up to eight CS regions of programmable size and programmable base addresses in a total address space of 1 GiB
- Supports transactions controlled by a firewall
- On-the-fly error code detection using the Bose-Chaudhuri-Hocquenghem (BCH) ( $t = 4, 8, \text{ or } 16$ ) or Hamming code to improve the reliability of NAND with a minimum effect on software (NAND flash with 512-byte page size or greater)
- Fully pipelined operation for optimal memory bandwidth use
- The clock to the external memory is provided from GPMC functional clock divided by 1, 2, 3, or 4
- Supports programmable autoclock gating when no access is detected
- Independent and programmable control signal timing parameters for setup and hold time on a per-chip basis. Parameters are set according to the memory device timing parameters, with a timing granularity of one GPMC functional clock cycle.
- Flexible internal access time control (WAIT state) and flexible handshake mode using external WAIT pin monitoring
- Support bus keeping
- Support bus turnaround
- Prefetch and write posting engine associated with to achieve full performance from the NAND device with minimum effect on NOR/SRAM concurrent access

For more information, see *General-Purpose Memory Controller* section in the device TRM.

### 6.4.1.3 ELM

In the case of NAND modules with no internal correction capability, sometimes referred to as bare NAND, the correction process can be delegated to the error location module (ELM) used in conjunction with the GPMC.

The ELM supports the following features:

- 4, 8, and 16 bits per 512-byte block error location based on BCH algorithm
- Eight simultaneous processing contexts
- Page-based and continuous modes



- Interrupt generation when error location process completes:
  - When the full page has been processed in page mode
  - For each syndrome polynomial (checksum-like information) in continuous mode

For more information, see *Error Location Module* section in the device TRM.

#### 6.4.1.4 OCMC

There is one on-chip memory controller (OCMC) in the device.

The OCM Controller supports the following features:

- L3\_MAIN data interface:
  - Used for maximum throughput performance
  - 128-bit data bus width
  - Burst supported
- L4 interface (OCMC\_RAM only):
  - Used for access to configuration registers
  - 32-bit data bus width
  - Only single accesses supported
  - The L4 associated OCMC clock is two times lower than the L3 associated OCMC clock
- Error correction and detection:
  - Single error correction and dual error detection
  - 9-bit Hamming error correction code (ECC) calculated on 128-bit data word which is concatenated with memory address bits
  - Hamming distance of 4
  - Enable/Disable mode control through a dedicated register
  - Single bit error correction on a read transaction
  - Exclusion of repeated addresses from correctable error address trace history
  - ECC valid for all write transactions to an enabled region
  - Sub-128-bit writes supported via read modify write
- ECC Error Status Reporting:
  - Trace history buffer (FIFO) with depth of 4 for corrected error address
  - Trace history buffer with depth of 4 for non correctable error address and also including double error detection
  - Interrupt generation for correctable and uncorrectable detected errors
- ECC Diagnostics Configuration:
  - Counters for single error correction (SEC), double error detection (DED) and address error events (AEE)
  - Programmable threshold registers for exceptions associated with SEC, DED and AEE counters
  - Register control for enabling and disabling of diagnostics
  - Configuration registers and ECC status accessible through L4 interconnect
- Circular buffer for sliced based VIP frame transfers:
  - Up to 12 programmable circular buffers mapped with unique virtual frame addresses
  - On the fly (with no additional latency) address translation from virtual to OCMC circular buffer memory space
  - Virtual frame size up to 8 MiB and circular buffer size up to 1 MiB
  - Error handling and reporting of illegal CBUF addressing
  - Underflow and Overflow status reporting and error handling
  - Last access read/write address history
- Two Interrupt outputs configured independently to service either ECC or CBUF interrupt events

The OCM controller does not have a memory protection logic and does not support endianism conversion. For more information, see *On-Chip Memory (OCM) Subsystem* section in the device TRM.

### 6.4.1.5 Interprocessor Communication

#### 6.4.1.5.1 Mailbox

Communication between the on-chip processors of the device uses a queued mailbox-interrupt mechanism.

The queued mailbox-interrupt mechanism allows the software to establish a communication channel between two processors through a set of registers and associated interrupt signals by sending and receiving messages (mailboxes).

The device implements the following mailbox types:

- System mailbox:
  - Number of instances: 13
  - Used for communication between: MPU, DSP1, IPU1, and IPU2 subsystems
  - Reference name: MAILBOX(1..13)
- IVA mailbox:
  - Number of instances: 1
  - Used for communication between: IVA local user (ICONT1, or ICONT2) and three external users (selected among MPU, DSP1, IPU1, and IPU2 subsystems)
  - Reference name: IVA\_MBOX

Each mailbox module supports the following features:

- Parameters configurable at design time
  - Number of users
  - Number of mailbox message queues
  - Number of messages (FIFO depth) for each message queue
- 32-bit message width
- Message reception and queue-not-full notification using interrupts
- Support of 16-/32-bit addressing scheme
- Power management support

For more information, see *Mailbox* chapter in the device TRM.

#### 6.4.1.5.2 Spinlock

The Spinlock module provides hardware assistance for synchronizing the processes running on multiple processors in the device:

- Dual Cortex®-A15 microprocessor unit (MPU) subsystem
- Digital signal processor (DSP) subsystems – DSP1 and DSP2
- Dual Cortex-M4 image processing unit (IPU) subsystems – IPU1 and IPU2

The Spinlock module implements 256 spinlocks (or hardware semaphores), which provide an efficient way to perform a lock operation of a device resource using a single read-access, avoiding the need of a readmodify- write bus transfer that the programmable cores are not capable of.

For more information, see *Spinlock* chapter in the device TRM.

### 6.4.2 EDMA

The primary purpose of the Enhanced Direct Memory Access (EDMA) controller is to service user-programmed data transfers between two memory-mapped slave endpoints on the device.

Typical usage of the EDMA controller includes:

- Servicing software-driven paging transfers (for example, data movement between external memory [such as SDRAM] and internal memory [such as DSP L2 SRAM])
- Servicing event-driven peripherals, such as a serial port
- Performing sorting or sub-frame extraction of various data structures
- Offloading data transfers from the main device CPUs, such as the C66x DSP CorePac or the Arm CorePac

The EDMA controller consists of two major principle blocks:

- EDMA Channel Controller
- EDMA Transfer Controller(s)

The EDMA Channel Controller (EDMACC) serves as the user interface for the EDMA controller. The EDMACC includes parameter RAM (PaRAM), channel control registers, and interrupt control registers. The EDMACC serves to prioritize incoming software requests or events from peripherals and submits transfer requests (TR) to the EDMA transfer controller.

The EDMA Transfer Controller (EDMATC) is responsible for data movement. The transfer request packets (TRP) submitted by the EDMACC contain the transfer context, based on which the transfer controller issues read/write commands to the source and destination addresses programmed for a given transfer.

There are two EDMA controllers present on this device:

- EDMA\_0, integrating:
  - 1 Channel Controller, referenced as: EDMACC\_0
  - 2 Transfer Controllers, referenced as: EDMACC\_0\_TC\_0 (or EDMATC\_0) and EDMACC\_0\_TC\_1 (or EDMATC\_1)
- EDMA\_1, integrating:
  - 1 Channel Controller, referenced as: EDMACC\_1
  - 2 Transfer Controllers, referenced as: EDMACC\_1\_TC\_0 (or EDMATC\_2) and EDMACC\_1\_TC\_1 (or EDMATC\_3)

The two EDMA channel controllers (EDMACC\_0 and EDMACC\_1) are functionally identical. For simplification, the unified name EDMACC shall be regularly used throughout this chapter when referring to EDMA Channel Controllers functionality and features.

The four EDMA transfer controllers (EDMACC\_0\_TC\_0, EDMACC\_0\_TC\_1, EDMACC\_1\_TC\_0 and EDMACC\_1\_TC\_1) are functionally identical. For simplification, the unified name EDMATC shall be regularly used throughout this chapter when referring to EDMA Transfer Controllers functionality and features.

Each EDMACC has the following features:

- Fully orthogonal transfer description
  - 3 transfer dimensions:
    - Array (multiple bytes)
    - Frame (multiple arrays)
    - Block (multiple frames)
  - Single event can trigger transfer of array, frame, or entire block
  - Independent indexes on source and destination
- Flexible transfer definition
  - Increment or constant addressing modes
  - Linking mechanism allows automatic PaRAM set update
  - Chaining allows multiple transfers to execute with one event

- 64 DMA channels
  - Channels triggered by either:
    - Event synchronization
    - Manual synchronization (CPU write to event set register)
    - Chain synchronization (completion of one transfer triggers another transfer)
  - Support for programmable DMA Channel to PaRAM mapping
- 8 Quick DMA (QDMA) channels
  - QDMA channels are triggered automatically upon writing to PaRAM set entry
  - Support for programmable QDMA channel to PaRAM mapping
- 512 PaRAM sets
  - Each PaRAM set can be used for a DMA channel, QDMA channel, or link set
- 2 transfer controllers/event queues
  - 16 event entries per event queue
- Interrupt generation based on:
  - Transfer completion
  - Error conditions
- Debug visibility
  - Queue water marking/threshold
  - Error and status recording to facilitate debug
- Memory protection support
  - Proxied memory protection for TR submission
  - Active memory protection for accesses to PaRAM and registers

Each EDMATC has the following features:

- Supports 2-dimensional (2D) transfers with independent indexes on source and destination (EDMACC manages the 3rd dimension)
- Up to 4 in-flight transfer requests (TR)
- Programmable priority levels
- Support for increment or constant addressing mode transfers
- Interrupt and error support
- Supports only little-endian operation in this device
- Memory mapped register (MMR) bit fields are fixed position in 32-bit MMR

For more information, see *Enhanced DMA* section in the device TRM.

### 6.4.3 Peripherals

#### 6.4.3.1 VIP

The VIP module provides video capture functions for the device. VIP incorporates a multi-channel raw video parser, various video processing blocks, and a flexible Video Port Direct Memory Access (VPDMA) engine to store incoming video in various formats. The device uses three instantiations of the VIP module giving the ability of capturing up to six video streams.

A VIP module includes the following main features:

- Two independently configurable external video input capture slices (Slice 0 and Slice 1) each of which has two video input ports, Port A and Port B, where Port A can be configured as a 24/16/8-bit port, and Port B is a fixed 8-bit port.
- Each video Port A can be operated as a port with clock independent input channels (with interleaved or separated Y/C data input). Embedded sync and external sync modes are supported for all input configurations.

- Support for a single external asynchronous pixel clock, up to 165 MHz per port.
- Pixel Clock Input Domain Port A supports up to one 24-bit input data bus, including BT.1120 style embedded sync for 16-bit and 24-bit data.
- Embedded Sync data interface mode supports single or multiplexed sources
- Discrete Sync data interface mode supports only single source input
- 24-bit data input plus discrete syncs can be configured to include:
  - 8-bit YUV422 (Y and U/V time interleaved)
  - 16-bit YUV422 (CbY and CrY time interleaved)
  - 24-bit YUV444
  - 16-bit RGB565
  - 24-bit RGB888
  - 12/16-bit RAW Capture
  - 24-bit RAW capture
- Discrete sync modes include:
  - VSYNC + HSYNC (FID determined by FID signal pin or HSYNC/VSYNC skew)
  - VSYNC + ACTVID + FID
  - VBLANK + ACTVID (ACTVID toggles in VBLANK) + FID
  - VBLANK + ACTVID (no ACTVID toggles in VBLANK) + FID
- VBLANK + ACTVID (no ACTVID toggles in VBLANK) + FID
  - Embedded syncs only
  - Pixel (2x or 4x) or Line multiplexed modes supported
  - Performs demultiplexing and basic error checking
  - Supports maximum of 9 channels in Line Mux (8 normal + 1 split line)
- Ancillary data capture support
  - For 16-bit or 24-bit input, ancillary data may be extracted from any single channel
  - For 8-bit time interleaved input, ancillary data can be chosen from the Luma channel, the Chroma channel, or both channels
  - Horizontal blanking interval data capture only supported when using discrete syncs (VSYNC + HSYNC or VSYNC + HBLANK)
  - Ancillary data extraction supported on multichannel capture as well as single source streams
- Format conversion and scaling
  - Programmable color space conversion
  - YUV422 to YUV444 conversion
  - YUV444 to YUV422 conversion
  - YUV422 to YUV420 conversion
  - YUV444 Source: YUV444 to YUV444, YUV444 to RGB888, YUV444 to YUV422, YUV444 to YUV420
  - RGB888 Source: RGB888 to RGB888, RGB888 to YUV444, RGB888 to YUV422, RGB888 to YUV420
  - YUV422 Source: YUV422 to YUV422, YUV422 to YUV420, YUV422 to YUV444, YUV422 to RGB888
  - Supports RAW to RAW (no processing)
  - Scaling and format conversions do not work for multiplexed input
- Supports up to 2047 pixels wide input - when scaling is engaged
- Supports up to 3840 pixels wide input - when only chroma up/down sampling is engaged, without scaling
- Supports up to 4095 pixels wide input - without scaling and chroma up/down sampling

- The maximum supported input resolution is further limited by:
  - Pixel clock and feature-dependent constraints
  - For RGB24-bit format (RAW data), the maximum frame width is limited to 2730 pixels

A VPDMA module includes the following main features:

- VPDMA output buffer size restriction feature, which ensures that writes do not exceed allocated memory buffer size
- Support for Tiled (2D) and raster addressing without bandwidth penalty
- Dual clients per channel allows for capture of scaled and nonscaled versions of the data stream (nonmultiplexed mode only)
- Start on new frame capability
- Interrupt every X number of frames
- Interrupt every X lines (synced to frame start)

For more information, see *Video Input Port* section in the device TRM.

#### 6.4.3.2 DSS

Display Port Interfaces (DPI) is available in DSS named DPI Video Output (VOUT).

VOUT interface consists of:

- 24-bit data bus (data[23:0])
- Horizontal synchronization signal (HSYNC)
- Vertical synchronization signal (VSYNC)
- Data enable (DE)
- Field ID (FID)
- Pixel clock (CLK)

For more information, see *Display Subsystem* chapter in the device TRM.

#### 6.4.3.3 Timers

The device has 16 general-purpose (GP) timers (TIMER1 - TIMER16), two watchdog timers, and a 32-kHz synchronized timer (COUNTER\_32K) that have the following features:

- Dedicated input trigger for capture mode and dedicated output trigger/pulse width modulation (PWM) signal
- Interrupts generated on overflow, compare, and capture
- Free-running 32-bit upward counter
- Supported modes:
  - Compare and capture modes
  - Auto-reload mode
  - Start-stop mode
- On-the-fly read/write register (while counting)

The device has two system watchdog timer (WD\_TIMER1 and WD\_TIMER2) that have the following features:

- Free-running 32-bit upward counter
- On-the-fly read/write register (while counting)
- Reset upon occurrence of a timer overflow condition

WD\_TIMER2 is available in all devices as a system watchdog timer. WD\_TIMER1 is only supported in security enabled devices.

The watchdog timer is used to provide a recovery mechanism for the device in the event of a fault condition, such as a non-exiting code loop.

For more information, see *General-Purpose Timers* section in the device TRM.

#### 6.4.3.4 I2C

The device contains five multimaster high speed (HS) inter-integrated circuit (I2C) controllers (I2C<sub>i</sub> modules, where  $i = 1, 2, 3, 4, 5$ ) each of which provides an interface between a local host (LH), such as a digital signal processor (DSP), and any I2C-bus-compatible device that connects through the I2C serial bus. External components attached to the I2C bus can serially transmit and receive up to 8 bits of data to and from the LH device through the 2-wire I2C interface.

Each multimaster HS I2C controller can be configured to act like a slave or master I2C-compatible device.

I2C1 and I2C2 controllers have dedicated I2C compliant open drain buffers, and support Fast mode (up to 400Kbps). I2C3, I2C4 and I2C5 controllers are multiplexed with standard LVCMOS IO and connected to emulate open drain. I2C emulation is achieved by configuring the LVCMOS buffers to output Hi-Z instead of driving high when transmitting logic 1. These controllers support HS mode (up to 3.4Mbps).

For more information, see *Multimaster High Speed I2C Controller (I2C)* section in the device TRM.

#### 6.4.3.5 HDQ1W

The HDQ1W module implements the hardware protocol of the master functions of the TI/Benchmark HDQ and the Dallas Semiconductor 1-Wire® protocols. These protocols use a single wire for communication between the master (HDQ1W controller) and the slaves (HDQ/1-Wire external compliant devices).

The HDQ1W has a generic L4 interface and is intended to be used in an interrupt-driven fashion. The 1-pin interface is implemented as an open-drain output at the device level.

The main features supported by the HDQ1W are the following:

- Benchmark HDQ protocol
- Dallas Semiconductor 1-Wire protocol
- Power-down mode

The HDQ1W provides a communication rate of 5 Kbps over an address space of 128 bytes.

A typical application of the HDQ1W is the communication with battery monitor (gas gauge) integrated circuits.

For more information, see *HDQ/1-Wire in chapter Serial Communication Interfaces* section in the device TRM.

#### 6.4.3.6 UART

The UART is a simple L4 slave peripheral that utilizes the DMA\_SYSTEM or EDMA for data transfer or IRQ polling via CPU. There are 10 UART modules in the device. Only one UART supports IrDA features. Each UART can be used for configuration and data exchange with a number of external peripheral devices or interprocessor communication between devices.

##### 6.4.3.6.1 UART Features

The UART<sub>i</sub> (where  $i = 1$  to 10) include the following features:

- 16C750 compatibility
- 64-byte FIFO buffer for receiver and 64-byte FIFO for transmitter
- Programmable interrupt trigger levels for FIFOs
- Baud generation based on programmable divisors N (where  $N = 1 \dots 16,384$ ) operating from a fixed functional clock of 48 MHz or 192 MHz

Oversampling is programmed by software as 16 or 13. Thus, the baud rate computation is one of two options:

- Baud rate = (functional clock / 16) / N

- Baud rate = (functional clock / 13) / N
- This software programming mode enables higher baud rates with the same error amount without changing the clock source
- Break character detection and generation
- Configurable data format:
  - Data bit: 5, 6, 7, or 8 bits
  - Parity bit: Even, odd, none
  - Stop-bit: 1, 1.5, 2 bit(s)
- Flow control: Hardware (RTS/CTS) or software (XON/XOFF)
- The 48 MHz functional clock option allows baud rates up to 3.6 Mbps
- The 192 MHz functional clock option allows baud rates up to 12 Mbps
- UART1 module has extended modem control signals (DCD, RI, DTR, DSR)
- UART3 supports IrDA

#### 6.4.3.6.2 IrDA Features

UART3 supports the following IrDA key features:

- Support of IrDA 1.4 slow infrared (SIR), medium infrared (MIR), and fast infrared (FIR) communications:
  - Frame formatting: Addition of variable beginning-of-frame (xBOF) characters and end-of-frame (EOF) characters
  - Uplink/downlink cyclic redundancy check (CRC) generation/detection
  - Asynchronous transparency (automatic insertion of break character)
  - Eight-entry status FIFO (with selectable trigger levels) to monitor frame length and frame errors
  - Framing error, CRC error, illegal symbol (FIR), and abort pattern (SIR, MIR) detection

#### 6.4.3.6.3 CIR Features

The CIR mode uses a variable pulse-width modulation (PWM) technique (based on multiples of a programmable  $t$  period) to encompass the various formats of infrared encoding for remote-control applications. The CIR logic transmits data packets based on a user-definable frame structure and packet content.

The CIR (UART3 only) includes the following features to provide CIR support for remote-control applications:

- Transmit mode only (receive mode is not supported)
- Free data format (supports any remote-control private standards)
- Selectable bit rate
- Configurable carrier frequency
- 1/2, 5/12, 1/3, or 1/4 carrier duty cycle

For more information, see *UART/IrDA/CIR* section in the device TRM.

#### 6.4.3.7 McSPI

The McSPI is a master/slave synchronous serial bus. There are four separate McSPI modules (McSPI1, McSPI2, McSPI3, and McSPI4) in the device. All these four modules support up to four external devices (four chip selects) and are able to work as both master and slave.

The McSPI modules include the following main features:

- Serial clock with programmable frequency, polarity, and phase for each channel
- Wide selection of McSPI word lengths, ranging from 4 to 32 bits
- Up to four master channels, or single channel in slave mode



- Master multichannel mode:
  - Full duplex/half duplex
  - Transmit-only/receive-only/transmit-and-receive modes
  - Flexible input/output (I/O) port controls per channel
  - Programmable clock granularity
  - McSPI configuration per channel. This means, clock definition, polarity enabling and word width
- Single interrupt line for multiple interrupt source events
- Power management through wake-up capabilities
- Enable the addition of a programmable start-bit for McSPI transfer per channel (start-bit mode)
- Supports start-bit write command
- Supports start-bit pause and break sequence
- Programmable timing control between chip select and external clock generation
- Built-in FIFO available for a single channel

For more information, see *Multichannel Serial Peripheral Interface* section in the device TRM.

#### 6.4.3.8 QSPI

The quad serial peripheral interface (QSPI) module is a kind of SPI module that allows single, dual, or quad read access to external SPI devices. This module has a memory mapped register interface, which provides a direct interface for accessing data from external SPI devices and thus simplifying software requirements. The QSPI works as a master only.

The QSPI supports the following features:

- General SPI features:
  - Programmable clock divider
  - Six pin interface
  - Programmable length (from 1 to 128 bits) of the words transferred
  - Programmable number (from 1 to 4096) of the words transferred
  - 4 external chip-select signals
  - Support for 3-, 4-, or 6-pin SPI interface
  - Optional interrupt generation on word or frame (number of words) completion
  - Programmable delay between chip select activation and output data from 0 to 3 QSPI clock cycles
  - Programmable signal polarities
  - Programmable active clock edge
  - Software-controllable interface allowing for any type of SPI transfer
  - Control through L3\_MAIN configuration port
- Serial flash interface (SFI) features:
  - Serial flash read/write interface
  - Additional registers for defining read and write commands to the external serial flash device
  - 1 to 4 address bytes
  - Fast read support, where fast read requires dummy bytes after address bytes; 0 to 3 dummy bytes can be configured.
  - Dual read support
  - Quad read support
  - Little-endian support only
  - Linear increment addressing mode only

The QSPI supports only dual and quad reads. Dual or quad writes are not supported. In addition, there is no "pass through" mode supported where the data present on the QSPI input is sent to its output.

For more information, see *Quad Serial Peripheral Interface* section in the device TRM.

### 6.4.3.9 McASP

The McASP functions as a general-purpose audio serial port optimized to the requirements of various audio applications. The McASP module can operate in both transmit and receive modes. The McASP is useful for time-division multiplexed (TDM) stream, Inter-IC Sound (I2S) protocols reception and transmission as well as for an intercomponent digital audio interface transmission (DIT). The McASP has the flexibility to gluelessly connect to a Sony/Philips digital interface (S/PDIF) transmit physical layer component.

Although intercomponent digital audio interface reception (DIR) mode (that is, S/PDIF stream receiving) is not natively supported by the McASP module, a specific TDM mode implementation for the McASP receivers allows an easy connection to external DIR components (for example, S/PDIF to I2S format converters).

The device have integrated 8 McASP modules (McASP1-McASP8) with:

- McASP1 and McASP2 supporting 16 channels with independent TX/RX clock/sync domain
- McASP3 through McASP8 modules supporting 4 channels with independent TX/RX clock/sync domain

For more information, see *Multichannel Audio Serial Port* section in the device TRM.

### 6.4.3.10 USB

SuperSpeed USB DRD Subsystem has three instances in the device providing the following functions:

- USB1: SuperSpeed (SS) USB 3.0 Dual-Role-Device (DRD) subsystem with integrated SS (USB3.0) PHY and HS/FS (USB2.0) PHY
- USB2: High Speed (HS) USB 2.0 Dual-Role-Device (DRD) subsystem with integrated HS/FS PHY

SuperSpeed USB DRD Subsystem has the following features:

- Dual-role-device (DRD) capability:
  - Supports USB Peripheral (or Device) mode at speeds SS (5 Gbps) (USB1 only), HS (480 Mbps), and FS (12 Mbps)
  - Supports USB Host mode at speeds SS (5 Gbps) (USB1 only), HS (480 Mbps), FS (12 Mbps), and LS (1.5 Mbps)
  - USB static peripheral operation
  - USB static host operation
  - Flexible stream allocation
  - Stream priority
  - External Buffer Control
- Each instance contains single xHCI controller with the following features:
  - Internal DMA controller
  - Descriptor caching and data prefetching
  - Interrupt moderation and blocking
  - Power management USB3.0 states for U0, U1, U2, and U3
  - Dynamic FIFO memory allocation for all endpoints
  - Supports all modes of transfers (control, bulk, interrupt, and isochronous)
  - Supports high bandwidth ISO mode
- Connects to an external charge pump for VBUS 5 V generation
- USB-HS PHY (USB2PHY1 and USB2PHY2 for USB1 and USB2, respectively): contain the USB functions, drivers, receivers, and pads for correct D+/D– signalling

For more information, see *SuperSpeed USB DRD* section in the device TRM.

#### 6.4.3.11 SATA

The SATA host controller handles data interactions between a local host system memory and a SATA mass storage device with minimal local host (LH) intervention.

In contrast to the parallel 16-bit - ATA (PATA) interface, the SATA interface takes advantage of serial data transmission/reception over a differential pair of conductors. SATA uses the command set from the ATA/ATAPI-6 standard augmented with native command queuing (NCQ) commands optimized for the serialized interface.

The device has one embedded SATA host bus adapter (HBA) controller with a single port.

For more information, see *SATA Controller* section in the device TRM.

#### 6.4.3.12 PCIe

The Peripheral Component Interconnect Express (PCIe) module is a multi-lane I/O interconnect that provides low pin-count, high reliability, and high speed data transfer at rates of up to 5.0 Gbps per lane, per direction, for serial links on backplanes and printed wiring boards. It is a 3-rd Generation I/O Interconnect technology succeeding PCI and ISA bus that is designed to be used as a general-purpose serial I/O interconnect. It is also used as a bridge to other interconnects like USB2/3.0, GbE MAC, and so forth.

The PCI-Express standard predecessor - PCI, is a parallel bus architecture that is increasingly difficult to scale-up in bandwidth, which is usually performed by increasing the number of data signal lines. The PCIe architecture was developed to help minimize I/O bus bottlenecks within systems and to provide the necessary bandwidth for high speed, chip-to-chip, and board-to-board communications within a system. It is designed to replace the PCI-based shared, parallel bus signaling technology that is approaching its practical performance limits while simplifying the interface design.

The device instantiates two PCIe subsystems (PCIe\_SS1 and PCIe\_SS2). The PCIe controller is capable to operate either in Root Complex (RC) or in End Point (EP) PCIe mode. The device PCIe\_SS1 controller supports up to two 16-bit data lanes on its PIPE port. The device PCIe\_SS2 controller supports only one 16-bit data lane on its PIPE port.

When the PCIe\_SS1 controller PIPE port is configured to operate in a single-lane mode, it operates on a single pair of PCIe PHY serializer and deserializer - PCIe1\_PHY\_TX/PCIe1\_PHY\_RX. When PCIe\_SS1 PIPE is configured to operate in dual-lane mode, it operates on two pairs of PCIe PHY serializer and deserializer - PCIe1\_PHY\_TX/PCIe1\_PHY\_RX and PCIe2\_PHY\_TX/PCIe2\_PHY\_RX, respectively. The single-lane PCIe\_SS2 controller PIPE port (if enabled) can operate only on the PCIe2\_PHY\_TX/PCIe2\_PHY\_RX pair. Hereby, if PCIe\_SS2 controller is used, the PCIe\_SS1 can operate only in a single-lane mode on the PCIe1\_PHY\_TX/PCIe1\_PHY\_RX. In addition, PCIe PHY subsystem encompasses a PCIe PCS (physical coding sublayer), a PCIe power management logic, APLL, a DPLL reference clock generator and an APLL clock low-jitter buffer.

- The PCIe Controller implements the transport and link layers of the PCIe interface protocol.
- PCIe PCS (a physical coding sublayer component) converts a 8-bit portion of parallel data over a PCIe lane to a 10-bit parallel data to adapt the process of serialization and deserialization in the TX/RX PHYs to various requirements. At the same time it transforms the transmission rate to maintain the PCIe Gen2 bandwidth (5 Gbps) on both sides (PCIe controller and PHY).
- A multiplexer logic which adds flexibility to connect a PCIe controller hardware mapped PCS logic output to a single (for the single-lane PCIe\_SS2 controller) or to a couple (for the 2-lane PCIe\_SS1 controller) of PHY ports at a time
- Physical layer (PHY) serializer/deserializer components with associated power control logic, building the so called PMA (physical media attachment) part of the PCIe\_PHY transceiver, as follows:
  - PCIe physical port 0 associated serializer (TX) - PCIe1\_PHY\_TX and deserializer (RX) - PCIe1\_PHY\_RX
  - PCIe physical port 1 associated serializer (TX) - PCIe2\_PHY\_TX and deserializer (RX) - PCIe2\_PHY\_RX

- DPLL\_PCIE\_REF is a DPLL clock source, controlled from the device PRCM, that provides a 100-MHz clock to the PCIe PHY serializer/deserializer components reference clock inputs.
- Both the PCIe\_SS1 and PCIe\_SS2 share the same APLL (APLLPCIE) which by default multiplies the DPLL\_PCIE\_REF (typically 100 MHz or 20 MHz) clock to 2.5 GHz.
- The APLLPCIE low-jitter buffer (ACSPCIE) and additional logic takes care to provide the PCIe APLL reference input clock.

PCIe module supports the following features:

- PCI Local Bus Specification revision 3.0
- PCI-Express Base 3.0 Specification, revision 1.0.

**At system level the device supports PCI-Express interface in the following configurations:**

- Each PCIe subsystem controller has support for PCIe Gen2 mode (5.0 Gbps per lane) and Gen1 mode (2.5 Gbps per lane).
- One PCIe (PCIe\_SS1) operates as Gen2 2-lanes supporting in either root-complex (RC) or end-point EP.
- Two PCIe (PCIe\_SS1 and PCIe\_SS2) operates Gen2 1-lane supporting either RC or EP with the possibility of one operating in Gen1 and one in Gen2.
- PCIe\_SS1 can be configured to operate in either 2-Lane (dual lane) or 1-Lane (single lane) mode, as follows:
  - Single Lane - lane 0 mapped to the PCIe port 0 of the device
  - Flexible dual lane configuration - lanes 0 and 1 can be swapped on the two PCIe ports
- PCIe\_SS2 can only operate in 1-Lane mode, as follows:
  - Single Lane - lane 0 mapped to the device PCIe port 1
 When PCIe\_SS1 is configured to operate in dual-lane mode, PCIe\_SS2 is in-operable as both PCIe1\_PHY\_RX/TX and PCIe2\_PHY\_RX/TX are assigned to PCIe\_SS1, and thereby NOT available to PCIe\_SS2.

**The main features of a device PCIe controller are:**

- 16-bit operation at 250 MHz on PIPE interface (per 16-bit lane)
- One master port on the L3\_MAIN supporting 32-bit address and 64-bit data bus.
- PCIe\_SS1 master port dedicated MMU (device MMU2) on L3\_MAIN path, to which PCIe traffic can be optionally mapped.
- One slave port on the L3\_MAIN supporting 29-bit address and 64-bit data bus.
- Maximum outbound payload size of 64 Bytes (the L3 Interconnect PCIe1/2 target ports split bursts of size > 64 Bytes to the into multiple 64 Byte bursts)
- Maximum inbound payload size of 256 Bytes (internally converted to 128 Byte - bursts)
- No remote read request size limit: implicit support for 4 KiB-size and greater
- Support of EP legacy mode
- Support of inbound I/O accesses in EP legacy mode
- PIPE interface features fixed-width (16-bit data per lane) and dynamic frequency to switch between PCIe Gen1 and Gen2.
- Ultra-low transmit and receive latency
- Automatic Lane reversal as specified in the PCI-Express Base 3.0 Specification, revision 1.0 (transmit and receive)
- Polarity inversion on receive
- Single Virtual Channel (VC0) and Single Traffic Class (TC0)
- Single Function in End point mode
- Automatic credit management
- ECRC generation and checking

- All PCI Device Power Management D-states with the exception of D3<sub>cold</sub>/L2 state
- PCI-Express Active State Power Management (ASPM) state L0s and L1 (with exceptions)
- PCI-Express Link Power Management states except for L2 state
- PCI-Express Advanced Error Reporting (AER)
- PCI-Express messages for both transmit and receive
- Filtering for Posted, Non-Posted, and Completion traffic
- Configurable BAR filtering, I/O filtering, configuration filtering and completion lookup/timeout
- Access to configuration space registers and external application memory mapped registers through ECAM mechanism.
- Legacy PCI Interrupts reception (RC) and generation (EP)
- 2 x hardware interrupts per PCIe\_SS1 and PCIe\_SS2 controller mapped via the device Interrupt Crossbar (IRQ\_CROSSBAR) to multiple device host (MPU, DSP, and so forth) interrupt controllers in the device
- MSIs generation and reception
- PCIe\_PHY Loopback in RC mode

For more information, see *PCIe Controller* section in the device TRM.

### 6.4.3.13 CAN

#### 6.4.3.13.1 DCAN

The device provides one DCAN interface for supporting distributed realtime control with a high level of security.

The DCAN interface implements the following features:

- Supports CAN protocol version 2.0 part A, B
- Bit rates up to 1 MBit/s
- 64 message objects
- Individual identifier mask for each message object
- Programmable FIFO mode for message objects
- Programmable loop-back modes for self-test operation
- Suspend mode for debug support
- Automatic bus on after Bus-Off state by a programmable 32-bit timer
- Message RAM single error correction and double error detection (SECDED) mechanism
- Direct access to Message RAM during test mode
- Support for two interrupt lines: Level 0 and Level 1, plus separate ECC interrupt line
- Local power down and wakeup support
- Automatic message RAM initialization
- Support for DMA access

For more information, see *DCAN* section in the device TRM.

#### 6.4.3.13.2 MCAN-FD

The device supports one MCAN-FD module connecting to the CAN network through external (for the device) transceiver for connection to the physical layer. The MCAN-FD module supports up to 5 Mbit/s data rate and is compliant to ISO 11898-1:2015.

The MCAN-FD module implements the following features:

- Conforms with ISO 11898-1:2015
- Full CAN FD support (up to 64 data bytes)

- SAE J1939 support
- Up to 32 dedicated Transmit Buffers
- Configurable Transmit FIFO, up to 32 elements
- Configurable Transmit Queue, up to 32 elements
- Configurable Transmit Event FIFO, up to 32 elements
- Up to 64 dedicated Receive Buffers
- Two configurable Receive FIFOs, up to 64 elements each
- Up to 128 filter elements
- Internal Loopback mode for self-test
- Maskable interrupts, two interrupt lines
- Two clock domains (CAN clock/Host clock)
- Parity/ECC support - Message RAM single error correction and double error detection (SECDED) mechanism
- Local power-down and wakeup support
- Timestamp Counter

For more information, see *MCAN* section in the device TRM.

#### 6.4.3.14 GMAC\_SW

The three-port gigabit ethernet switch subsystem (GMAC\_SW) provides ethernet packet communication and can be configured as an ethernet switch. It provides the gigabit media independent interface (G/MII) in MII mode, reduced gigabit media independent interface (RGMI), reduced media independent interface (RMII), and the management data input output (MDIO) for physical layer device (PHY) management.

The GMAC\_SW subsystem provides the following features:

- Two Ethernet ports (port 1 and port 2) with selectable RGMII, RMII, and G/MII (in MII mode only) interfaces plus internal Communications Port Programming Interface (CPPI 3.1) on port 0
- Synchronous 10/100/1000 Mbit operation
- Wire rate switching (802.1d)
- Non-blocking switch fabric
- Flexible logical FIFO-based packet buffer structure
- Four priority level Quality Of Service (QOS) support (802.1p)
- CPPI 3.1 compliant DMA controllers
- Support for Audio/Video Bridging (P802.1Qav/D6.0)
- Support for IEEE 1588 Clock Synchronization (2008 Annex D and Annex F)
  - Timing FIFO and time stamping logic embedded in the subsystem
- Device Level Ring (DLR) Support
- Energy Efficient Ethernet (EEE) support (802.3az)
- Flow Control Support (802.3x)

- Address Lookup Engine (ALE)
  - 1024 total address entries plus VLANs
  - Wire rate lookup
  - Host controlled time-based aging
  - Multiple spanning tree support (spanning tree per VLAN)
  - L2 address lock and L2 filtering support
  - MAC authentication (802.1x)
  - Receive-based or destination-based multicast and broadcast rate limits
  - MAC address blocking
  - Source port locking
  - OUI (Vendor ID) host accept/deny feature
  - Remapping of priority level of VLAN or ports
- VLAN support
  - 802.1Q compliant
    - Auto add port VLAN for untagged frames on ingress
    - Auto VLAN removal on egress and auto pad to minimum frame size
- Ethernet Statistics:
  - EtherStats and 802.3Stats Remote network Monitoring (RMON) statistics gathering (shared)
  - Programmable statistics interrupt mask when a statistic is above one half its 32-bit value
- Flow Control Support (802.3x)
- Digital loopback and FIFO loopback modes supported
- Maximum frame size 2016 bytes (2020 with VLAN)
- 8k (2048 × 32) internal CPPI buffer descriptor memory
- Management Data Input/Output (MDIO) module for PHY Management
- Programmable interrupt control with selected interrupt pacing
- Emulation support
- Programmable Transmit Inter Packet Gap (IPG)
- Reset isolation (switch function remains active even in case of all device resets except for POR pin reset and ICEPICK cold reset)
- Full duplex mode supported in 10/100/1000 Mbps. Half-duplex mode supported only in 10/100 Mbps.
- IEEE 802.3 gigabit Ethernet conformant

For more information, see *Gigabit Ethernet Switch (GMAC\_SW)* section in the device TRM.

#### 6.4.3.15 eMMC/SD/SDIO

The eMMC™/SD/SDIO host controller provides an interface between a local host (LH) such as a microprocessor unit (MPU) or digital signal processor (DSP) and either eMMC, SD memory cards, or SDIO cards and handles eMMC/SD/SDIO transactions with minimal LH intervention.

Optionally, the controller is connected to the L3\_MAIN interconnect to have a direct access to system memory. It also supports two direct memory access (DMA) slave channels or a DMA master access (in this case, slave DMA channels are deactivated) depending on its integration.

The eMMC/SD/SDIO host controller deals with eMMC/SD/SDIO protocol at transmission level, data packing, adding cyclic redundancy checks (CRCs), start/end bit, and checking for syntactical correctness.

The application interface can send every eMMC/SD/SDIO command and poll for the status of the adapter or wait for an interrupt request, which is sent back in case of exceptions or to warn of end of operation.

The application interface can read card responses or flag registers. It can also mask individual interrupt sources. All these operations can be performed by reading and writing control registers. The eMMC/SD/SDIO host controller also supports two DMA channels.

There are four eMMC/SD/SDIO host controllers inside the device. gives an overview of the eMMC/SD/SDIOi (i = 1 to 4) controllers.

Each controller has the following data width:

- eMMC/SD/SDIO1 - 4-bit wide data bus
- eMMC/SD/SDIO2 - 8-bit wide data bus
- eMMC/SD/SDIO3 - 8-bit wide data bus
- eMMC/SD/SDIO4 - 4-bit wide data bus

The eMMC/SD/SDIOi controller is also referred to as MMCi.

Compliance with standards:

- Full compliance with MMC/eMMC command/response sets as defined in the JC64 MMC/eMMC Standard Specification, v4.5.
- Full compliance with SD command/response sets as defined in the SD Physical Layer Specification v3.01
- Full compliance with SDIO command/response sets and interrupt/read-wait suspend-resume operations as defined in the SD part E1 Specification v3.00
- Full compliance with SD Host Controller Standard Specification sets as defined in the SD card Specification Part A2 v3.00

Main features of the eMMC/SD/SDIO host controllers:

- Flexible architecture allowing support for new command structure
- 32-bit wide access bus to maximize bus throughput
- Designed for low power
- Programmable clock generation
- Dedicated DLL to support SDR104 mode (MMC1 only)
- Dedicated DLL to support HS200 mode (MMC2 only)
- Card insertion/removal detection and write protect detection
- L4 slave interface supports:
  - 32-bit data bus width
  - 8/16/32 bit access supported
  - 9-bit address bus width
  - Streaming burst supported only with burst length up to 7
  - WNP supported
- L3 initiator interface Supports:
  - 32-bit data bus width
  - 8/16/32 bit access supported
  - 32-bit address bus width
  - Burst supported
- Built-in 1024-byte buffer for read or write
- Two DMA channels, one interrupt line
- Support JC 64 v4.4.1 boot mode operations
- Support SDA 3.00 Part A2 programming model
- Support SDA 3.00 Part A2 DMA feature (ADMA2)



- Supported data transfer rates:
  - MMCi supports the following SD v3.0 data transfer rates:
    - DS mode (3.3 V IOs): up to 12 MBps (24 MHz clock)
    - HS mode (3.3 V IOs): up to 24 MBps (48 MHz clock)
    - SDR12 (1.8 V IOs): up to 12 MBps (24 MHz clock)
    - SDR25 (1.8 V IOs): up to 24 MBps (48 MHz clock)
    - SDR50 (1.8 V IOs): up to 48 MBps (96 MHz clock) - MMC1 and MMC3 only
    - DDR50 (1.8 V IOs): up to 48 MBps (48 MHz clock) - MMC1 only
    - SDR104 (1.8 V IOs) cards can be supported up to 192 MHz clock (96 MBps max) - MMC1 only
  - MMCi supports the Default SD mode 1-bit data transfer up to 24 Mbps (3 MBps)
  - Only MMC2 supports also the following JC64 v4.5 data transfer rates:
    - Up to 192 MBps in eMMC mode, 8-bit SDR mode (192 MHz clock frequency)
    - Up to 96 MBps in eMMC mode, 8-bit DDR mode (48 MHz clock frequency)
- All eMMC/SD/SDIO controllers are connected to 1.8V/3.3V compatible I/Os to support 1.8V/3.3V signaling

---

#### NOTE

eMMC functionality is supported fully by MMC2 only. The other MMC modules are capable of eMMC functionality, but are not timing-optimized for eMMC.

---

The differences between the eMMC/SD/SDIO host controllers and a standard SD host controller defined by the *SD Card Specification, Part A2, SD Host Controller Standard Specification, v3.0* are:

- The clock divider in the eMMC/SD/SDIO host controller supports a wider range of frequency than specified in the *SD Memory Card Specifications, v3.0*. The eMMC/SD/SDIO host controller supports odd and even clock ratio.
- The eMMC/SD/SDIO host controller supports configurable busy time-out.
- ADMA2 64-bit mode is not supported.
- There is no external LED control.

---

#### NOTE

Only even ratios are supported in DDR mode.

---

For more information, see *eMMC/SD/SDIO* chapter in the device TRM.

### 6.4.3.16 GPIO

The general-purpose interface combines eight general-purpose input/output (GPIO) banks.

Each GPIO module provides 32 dedicated general-purpose pins with input and output capabilities; thus, the general-purpose interface supports up to 247 pins.

These pins can be configured for the following applications:

- Data input (capture)/output (drive)
- Keyboard interface with a debounce cell
- Interrupt generation in active mode upon the detection of external events. Detected events are processed by two parallel independent interrupt-generation submodules to support biprocessor operations
- Wake-up request generation in idle mode upon the detection of external events

---

**NOTE**

The general-purpose input/output  $i$  ( $i = 1$  to 8) bank is also referred to as GPIO $i$ .

---

For more information, see *General-Purpose Interface* chapter in the device TRM.

**6.4.3.17 ePWM**

An effective PWM peripheral must be able to generate complex pulse width waveforms with minimal CPU overhead or intervention. It needs to be highly programmable and very flexible while being easy to understand and use. The ePWM unit described here addresses these requirements by allocating all needed timing and control resources on a per PWM channel basis. Cross coupling or sharing of resources has been avoided; instead, the ePWM is built up from smaller single channel modules with separate resources and that can operate together as required to form a system. This modular approach results in an orthogonal architecture and provides a more transparent view of the peripheral structure, helping users to understand its operation quickly.

Each ePWM module supports the following features:

- Dedicated 16-bit time-base counter with period and frequency control
- Two PWM outputs (EPWMxA and EPWMxB) that can be used in the following configurations:
  - Two independent PWM outputs with single-edge operation
  - Two independent PWM outputs with dual-edge symmetric operation
  - One independent PWM output with dual-edge asymmetric operation
- Asynchronous override control of PWM signals through software.
- Programmable phase-control support for lag or lead operation relative to other ePWM modules.
- Hardware-locked (synchronized) phase relationship on a cycle-by-cycle basis.
- Dead-band generation with independent rising and falling edge delay control.
- Programmable trip zone allocation of both cycle-by-cycle trip and one-shot trip on fault conditions.
- A trip condition can force either high, low, or high-impedance state logic levels at PWM outputs.
- Programmable event prescaling minimizes CPU overhead on interrupts.
- PWM chopping by high-frequency carrier signal, useful for pulse transformer gate drives.

For more information, see *Enhanced PWM (ePWM) Module* chapter in the device TRM.

**6.4.3.18 eCAP**

Uses for eCAP include:

- Sample rate measurements of audio inputs
- Speed measurements of rotating machinery (for example, toothed sprockets sensed via Hall sensors)
- Elapsed time measurements between position sensor pulses
- 4 stage sequencer (Mod4 counter) which is synchronized to external events (ECAPx pin edges)
- Period and duty cycle measurements of pulse train signals
- Decoding current or voltage amplitude derived from duty cycle encoded current/voltage sensors

The eCAP module includes the following features:

- 32-bit time base counter
- 4-event time-stamp registers (each 32 bits)
- Edge polarity selection for up to four sequenced time-stamp capture events
- Interrupt on either of the four events
- Single shot capture of up to four event time-stamps
- Continuous mode capture of time-stamps in a four-deep circular buffer
- Absolute time-stamp capture

- Difference (Delta) mode time-stamp capture
- All above resources dedicated to a single input pin
- When not used in capture mode, the ECAP module can be configured as a single channel PWM output

For more information, see *Enhanced Capture (eCAP) Module* section in the device TRM.

#### 6.4.3.19 eQEP

A single track of slots patterns the periphery of an incremental encoder disk. These slots create an alternating pattern of dark and light lines. The disk count is defined as the number of dark/light line pairs that occur per revolution (lines per revolution). As a rule, a second track is added to generate a signal that occurs once per revolution (index signal: QEPI), which can be used to indicate an absolute position. Encoder manufacturers identify the index pulse using different terms such as index, marker, home position, and zero reference.

To derive direction information, the lines on the disk are read out by two different photo-elements that "look" at the disk pattern with a mechanical shift of 1/4 the pitch of a line pair between them. This shift is realized with a reticle or mask that restricts the view of the photo-element to the desired part of the disk lines. As the disk rotates, the two photo-elements generate signals that are shifted 90 degrees out of phase from each other. These are commonly called the quadrature QEPA and QEPB signals. The clockwise direction for most encoders is defined as the QEPA channel going positive before the QEPB channel.

The encoder wheel typically makes one revolution for every revolution of the motor or the wheel may be at a geared rotation ratio with respect to the motor. Therefore, the frequency of the digital signal coming from the QEPA and QEPB outputs varies proportionally with the velocity of the motor. For example, a 2000-line encoder directly coupled to a motor running at 5000 revolutions per minute (rpm) results in a frequency of 166.6 kHz, so by measuring the frequency of either the QEPA or QEPB output, the processor can determine the velocity of the motor.

For more information, see *Enhanced Quadrature Encoder Pulse (eQEP) Module* section in the device TRM.

#### 6.4.4 On-Chip Debug

Debugging a system that contains an embedded processor involves an environment that connects high-level debugging software running on a host computer to a low-level debug interface supported by the target device. Between these levels, a debug and trace controller (DTC) facilitates communication between the host debugger and the debug support logic on the target chip.

The DTC is a combination of hardware and software that connects the host debugger to the target system. The DTC uses one or more hardware interfaces and/or protocols to convert actions dictated by the debugger user to JTAG<sup>®</sup> commands and scans that execute the core hardware.

The debug software and hardware components let the user control multiple central processing unit (CPU) cores embedded in the device in a global or local manner. This environment provides:

- Synchronized global starting and stopping of multiple processors
- Starting and stopping of an individual processor
- Each processor can generate triggers that can be used to alter the execution flow of other processors

System topics include but are not limited to:

- System clocking and power-down issues
- Interconnection of multiple devices
- Trigger channels

For more information, see *On-chip Debug* chapter in the device TRM.

The device deploys Texas Instrument's CTools debug technology for on-chip debug and trace support. It provides the following features:

- External debug interfaces:
  - Primary debug interface - IEEE1149.1 (JTAG) or IEEE1149.7 (complementary superset of JTAG)
    - Used for debugger connection
    - Default mode is IEEE1149.1 but debugger can switch to IEEE1149.7 via an IEEE1149.7 adapter module
    - Controls ICEPick (generic test access port [TAP] for dynamic TAP insertion) to allow the debugger to access several debug resources through its secondary (output) JTAG ports (for more information, see *ICEPick Secondary TAPs* section in the device TRM).
  - Debug (trace) port
    - Can be used to export processor or system trace off-chip (to an external trace receiver)
    - Can be used for cross-triggering with an external device
    - Configured through debug resources manager (DRM) module instantiated in the debug subsystem
    - For more information about debug (trace) port, see *Debug (Trace) Port and Concurrent Debug Modes* section in the device TRM.
- JTAG based processor debug on:
  - Cortex-A15 in MPU
  - C66x in DSP1
  - Cortex-M4 (x2) in IPU1, IPU2
  - Arm968 (x2) in IVA
- Dynamic TAP insertion
  - Controlled by ICEPick
  - For more information, see *Dynamic TAP Insertion* section in the device TRM.
- Power and clock management
  - Debugger can get the status of the power domain associated to each TAP.
  - Debugger may prevent the application software switching off the power domain.
  - Application power management behavior can be preserved during debug across power transitions.
  - For more information, see *Power and Clock Management* section in the device TRM.
- Reset management
  - Debugger can configure ICEPick to assert, block, or extend the reset of a given subsystem.
  - For more information, see *Reset Management* section in the device TRM.
- Cross-triggering
  - Provides a way to propagate debug (trigger) events from one processor, subsystem, or module to another:
    - Subsystem A can be programmed to generate a debug event, which can then be exported as a global trigger across the device.
    - Subsystem B can be programmed to be sensitive to the trigger line input and to generate an action on trigger detection.
  - Two global trigger lines are implemented
  - Device-level cross-triggering is handled by the XTRIG (TI cross-trigger) module implemented in the debug subsystem
  - Various Arm® CoreSight™ cross-trigger modules implemented to provide support for Arm® CoreSight™ triggers distribution
    - Arm® CoreSight™ Cross-Trigger Interface (CS\_CTI) modules
    - Arm® CoreSight™ Cross-Trigger Matrix (CS\_CTM) modules
  - For more information about cross-triggering, see *Cross-Triggering* section in the device TRM.

- Suspend
  - Provides a way to stop a closely coupled hardware process running on a peripheral module when the host processor enters debug state
  - For more information about suspend, see *Suspend* section in the device TRM.
- MPU watchpoint
  - Embedded in MPU subsystem
  - Provides visibility on MPU to EMIF direct paths
  - For more information, see *MPU Memory Adaptor (MPU\_MA) Watchpoint* section in the device TRM.
- Processor trace
  - Cortex-A15 (MPU) and C66x (DSP) processor trace is supported
  - Program trace only for MPU (no data trace)
  - MPU trace supported by a Arm® CoreSight™ Program Trace Macrocell (CS\_PTM) module
  - Three exclusive trace sinks:
    - Arm® CoreSight™ Trace Port Interface Unit (CS\_TPIU) – trace export to an external trace receiver
    - CTools Trace Buffer Router (CT\_TBR) in system bridge mode – trace export through USB
    - CT\_TBR in buffer mode – trace history store into on-chip trace buffer
  - For more information, see *Processor Trace* section in the device TRM.

- System instrumentation (trace)
  - Supported by a CTools System Trace Module (CT\_STM), implementing MIPI System Trace Protocol (STP) (rev 2.0)
  - Real-time software trace
    - MPU software instrumentation through Arm® CoreSight™ STM (CS\_STM) (STP2.0)
    - System-on-chip (SoC) software instrumentation through CT\_STM (STP2.0)
  - OCP watchpoint (OCP\_WP\_NOC)
    - OCP target traffic monitoring: OCP\_WP\_NOC can be configured to generate a trigger upon watchpoint match (that is, when target transaction attributes match the user-defined attributes).
    - SoC events trace
    - DMA transfer profiling
  - Statistics collector (performance probes)
    - Computes traffic statistics within a user-defined window and periodically reports to the user through the CT\_STM interface
    - Embedded in the L3\_MAIN interconnect
    - 10 instances:
      - 1 instance dedicated to target (SDRAM) load monitoring
      - 9 instances dedicated to master latency monitoring
  - IVA instrumentation (hardware accelerator [HWA] profiling)
    - Supported through a software message and system trace event (SMSET) module embedded in the IVA subsystem
  - Power-management events profiling (PM instrumentation [PMI])
    - Monitoring major power-management events. The PM state changes are handled as generic events and encapsulated in STP messages.
  - Clock-management events profiling (CM instrumentation [CMI])
    - Monitoring major clock management events. The CM state changes are handled as generic events and encapsulated in STP messages.
    - Two instances, one per CM
      - CM1 Instrumentation (CMI1) module mapped in the PD\_CORE\_AON power domain
      - CM2 Instrumentation (CMI2) module mapped in the PD\_CORE power domain
  - For more information, see *System Instrumentation* section in the device TRM.
- Performance monitoring
  - Supported by subsystem counter timer module (SCTM) for IPU
  - Supported by performance monitoring unit (PMU) for MPU subsystem

For more information, see *On-Chip Debug Support* chapter in the device TRM.

## 6.5 Identification

### 6.5.1 Revision Identification

For more information about Revision Identification, see [Section 8.1](#), *Device Nomenclature*.

### 6.5.2 Die Identification

The device part number identification data can be read in the [31:0] STD\_FUSE\_DIE\_ID\_2 bit-field of the CTRL\_WKUP\_STD\_FUSE\_DIE\_ID\_2 register.

For more information about Die Identification, see *AM574x Device Identification* section in the device TRM.

### 6.5.3 JTAG Identification

For more information about JTAG Identification, see *AM574x Device Identification* section in the device TRM.

### 6.5.4 ROM Code Identification

For more information about ROM Code Identification, see *Device Initialization by ROM Code* section in the device TRM.

## 6.6 Boot Modes

### 6.6.1 Boot Mode List

Table 6-1 and Table 6-2 describe the 16 sampled-on-reset sysboot pads used for selecting the boot peripherals, their boot sequence and all required configuration.

**Table 6-1. Sysboot Pads Description<sup>(1)</sup>**

PAD	DESCRIPTION
sysboot[15]	Used to permanently disable the internal PU/PD resistors on pads gpmc_a[27:24, 22:19].
sysboot[14]	Must be pulled to vss for proper device operation.
sysboot[13:10]	Used to configure the GPMC interface when booting from XIP/NAND memory connected to GPMC.
sysboot[9:8]	Selects the SYS_CLK1 clock speed. Must be set correctly according to the speed of the connected crystal.
sysboot[7:6]	Sector offset for the location of the redundant SBL images in QSPI.
sysboot[5:0]	Select interfaces or devices for the booting list

(1) Boards should be implemented with a mechanism to easily modify the pull-up/down state to enable any future modifications.

**Table 6-2. MMC2 Configuration<sup>(1)</sup>**

sysboot[15]	mmc2_dat[7:0] PULL-DOWN RESISTORS
0b0	Software re-configuration of pull resistors is allowed. Internal pull-downs on gpmc_a[n:19] are enabled by default to allow GPMC boot. Pulling low gpmc_a[n:19] is required in order to access the low-order address locations in the flash memory during boot (n = [27:24, 22:19] and depends on the memory volume).
0b1	Internal pull-down resistors permanently disabled to avoid contention with the recommended per eMMC standard pull-ups that should be present on PCB. Software re-configuration of internal pull resistors is disabled.

(1) When internal pull-downs are permanently disabled (sysboot[15] = 1), gpmc\_a[n:19] pads (where n = [27:24, 22:19]) require external pull-downs to enable GPMC boot.

All sysboot pads are sampled and latched onto the CTRL\_CORE\_BOOTSTRAP register (in control module) after POR. After booting, these pads can be used for other functions such as GPIOs, and the associated register bit field is not updated by the new functionality.

#### NOTE

If used as GPIOs, the sysboot[15:0] pads must be used only in output mode to ensure that the input values always match a certain hardware predefined boot pattern, interpreted after each POR.

For more information about Boot Mode List, see *Sysboot Configuration* section in the device TRM.

## 6.6.2 Boot Mode Pin Usage

### 6.6.2.1 GPMC Configuration for XIP/NAND

Table 6-3 describes the GPMC interface configuration used in XIP, fast XIP and NAND modes controlled by sysboot[13:10].

**Table 6-3. GPMC for XIP/NAND Configuration**

sysboot[13]	BUS WIDTH
0b0	8-bit
0b1	16-bit
sysboot[12:11]	A/D-MUXED/NON-MUXED DEVICE ON CS0
0b00	Non-muxed device
0b01	A/D-muxed device
sysboot[10]	WAIT-PIN MONITORING FOR READ ACCESSES
0b0	Disabled
0b1	Enabled

### 6.6.2.2 System Clock Speed Selection

There are three crystal speeds available to be selected by means of sysboot[9:8], as described in Table 6-4. User is responsible to set the correct value depending on the actual clock supplied to the device.

**Table 6-4. System Clock (SYS\_CLK1) Speed Selection**

sysboot[9:8]	SYS_CLK1 SPEED
0b00	Reserved
0b01	20 MHz
0b10	27 MHz
0b11	19.2 MHz

### 6.6.2.3 QSPI Redundant SBL Images Offset

Four options are available to set the offset between the redundant SBL images as described in Table 6-5. If not using the redundant SBL feature, there is no change required to sysboot pins as only the primary image is used and the sector offset is a don't care.

**Table 6-5. Offset Between Redundant Images**

sysboot[7:6]	OFFSET
0b00	64 KiB
0b01	128 KiB
0b10	256 KiB
0b11	512 KiB



For more information about Boot Mode Pin Usage, see *Sysboot Configuration* section in the device TRM.

### 6.6.3 Boot Mode Selection

#### 6.6.3.1 Booting Device Order Selection

The ROM code creates the device list (order) based on information gathered from the sysboot[5:0] external configuration pins sensed in the device CTRL\_CORE\_BOOTSTRAP register. The sysboot[5:0] configuration pads have two main purposes: configure ROM code software in terms of interfaces and devices used for booting and configuring hardware after a POR or cold reset.

The SYSBOOT pins are used to index a booting device list from a table with possible booting scenarios. The order of examined booting devices is from the first to the third devices.

The following names are used in the tables:

- Memory types:
  - Execute in place (XIP): NOR (CFI) flash memory or other XIP device
  - NAND: NAND flash memories (non-XIP)
  - SD: Removable SD card device
  - eMMC: eMMC™ memory device
  - QSPI\_1: 1-bit SPI flash memories
  - QSPI\_4: 4-bit (Quad) SPI flash memories
  - SATA: SATA-compatible devices such as solid state drives (SSDs) or hard-disk drives (HDDs)
- Peripheral interfaces:
  - USB: HS USB 2.0 interface
  - UART: UART interface
- [Table 6-6](#) lists the permanent booting devices in bold typeface.

#### NOTE

After a warm reset, the ROM code builds a device list featuring only the permanent booting devices (in **bold**)

[Table 6-6](#) lists the booting device order selected by ROM code depending on sysboot[5:0] pins.

**Table 6-6. Booting Devices Order**

sysboot[5:4]	sysboot[3:0]	FIRST DEVICE	SECOND DEVICE	THIRD DEVICE
<b>Peripheral Preferred Booting</b>				
0b00	0b0000	USB	<b>eMMC</b>	
0b00	0b0001	USB	<b>NAND</b>	
0b00	0b0010	USB	<b>SD</b>	<b>eMMC</b>
0b00	0b0011	USB	<b>SATA</b>	<b>SD</b>
0b00	0b0100	USB	UART	<b>XIP</b>
0b00	0b0101	SD	<b>XIP</b>	
0b00	0b0110	SD	<b>QSPI_1</b>	
0b00	0b0111	SD	<b>QSPI_4</b>	
0b00	0b1010	SD	<b>Fast XIP</b>	
<b>Recovery/Upgrade or Development Booting <sup>(1)</sup></b>				
0b01	0b0000	<b>USB</b>		
0b01	0b0011	<b>UART</b>		
0b01	0b0100	<b>SD</b>	USB	
0b01	0b0101	<b>SD</b>	USB	
0b01	0b0110	<b>SD</b>	USB	

**Table 6-6. Booting Devices Order (continued)**

sysboot[5:4]	sysboot[3:0]	FIRST DEVICE	SECOND DEVICE	THIRD DEVICE
0b01	0b0111	SD	USB	
0b01	0b1000	SD	USB	
0b01	0b1001	SD	USB	
0b01	0b1010	SD	USB	
0b01	0b1011	SD	USB	
<b>Memory Preferred Booting</b>				
0b10	0b0000	eMMC	USB	
0b10	0b0001	NAND	USB	
0b10	0b0010	SD	eMMC	USB
0b10	0b0011	SATA	SD	USB
0b10	0b0100	XIP	USB	UART
0b10	0b0101	XIP	SD	USB
0b10	0b0110	QSPI_1	SD	USB
0b10	0b0111	QSPI_4	SD	USB
<b>Production Booting<sup>(1)</sup></b>				
0b11	0b0000	SD		
0b11	0b0100	SATA		
0b11	0b0101	XIP		
0b11	0b0110	QSPI_1		
0b11	0b0111	QSPI_4		
0b11	0b1000	eMMC		
0b11	0b1001	NAND		
0b11	0b1010	Fast XIP		
0b11	0b1011	eMMC (boot part.) <sup>(2)</sup>		

(1) After 10 failed loops through the device list, ROM code initiates immediate global warm reset.

(2) The ROM code boots from eMMC boot partition. If the ROM code fails to retrieve the booting image, it does not try boot from the user area contrary to other eMMC options.

For more information about Boot Mode Selection, see *Sysboot Configuration* section in the device TRM.

## 7 Applications, Implementation, and Layout

### NOTE

Information in the following applications sections is not part of the TI component specification, and TI does not warrant its accuracy or completeness. TI's customers are responsible for determining suitability of components for their purposes. Customers should validate and test design implementation to confirm system functionality.

### 7.1 Power Supply Mapping

TPS659037 is the Power Management IC (PMIC) that should be used for the device designs. TI requires use of this PMIC for the following reasons:

- TI has validated its use with the device
- Board level margins including transient response and output accuracy are analyzed and optimized for the entire system
- Support for power sequencing requirements (refer to [Section 5.10.3, Power Supply Sequences](#))
- Support for Adaptive Voltage Scaling (AVS) Class 0 requirements, including TI provided software

Whenever we allow for combining of rails mapped on any of the SMPS outputs, the PDN guidelines that are the most stringent of the rails combined should be implemented for the particular supply rail.

It is possible that some voltage domains on the device are unused in some systems. In such cases, to ensure device reliability, it is still required that the supply pins for the specific voltage domains are connected to some core power supply output.

These unused supplies though can be combined with any of the core supplies that are used (active) in the system. For example, if IVA and GPU domains are not used, they can be combined with the CORE domain, thereby having a single power supply driving the combined CORE, IVA and GPU domains.

For the combined rail, the following relaxations do apply:

- The AVS voltage of active rail in the combined rail needs to be used to set the power supply
- The decoupling capacitance should be set according to the active rail in the combined rail

[Table 7-1](#) illustrates the approved and validated power supply connections to the device for the PMIC outputs of the TPS659037 PMIC.

**Table 7-1. TPS659037 Power Supply Connections<sup>(1)</sup>**

TPS659037 POWER SUPPLY	VALID COMBINATION 1	VALID COMBINATION 2
SMPS1/2 <sup>(2)</sup>	vdd_mpu	vdd_mpu
SMPS3	vdds_dds1, vdds_dds2	vdds_dds1, vdds_dds2
SMPS4/5	vdd_dspeve, vdd_gpu, vdd_iva	vdd_dspeve
SMPS6	vdd	vdd_gpu
SMPS7	SW configuration after boot	vdd
SMPS8	vdds18v	vdd_iva
SMPS9	SW configuration after boot 3.3V	vddshvx
LDO1	vddshv8	vddshv8
LDO2	vddshv5	vdds18v
LDO3	vdda_usb1, vdda_usb2, vdda_usb3, vdda_sata	vdda_usb1, vdda_usb2, vdda_usb3, vdda_sata
LDO4	vdda_hdmi, vdda_pcie, vdda_pcie0, vdda_pcie1	vdda_hdmi, vdda_pcie, vdda_pcie0, vdda_pcie1
LDO9	vdd_rtc	vdd_rtc
LDOLN	1.8V PLLs	1.8V PLLs
LDOUSB	vdda_usb3v3	vdda_usb3v3

- (1) Power consumption is highly application-specific. Separate analysis must be performed to ensure output current ratings (average and peak) is within the limits of the PMIC for all rails of the device.
- (2) Refer to the PMIC data manual for the latest [TPS659037](#) Specifications.
- (3) For more information on connectivity with the TPS659037 PMIC, see the [TPS659037 User's Guide to Power AM574x, AM572x, and AM571x](#).
- (4) A product's maximum ambient temperature, thermal system design and heat spreading performance could limit the maximum power dissipation below the full PMIC capacity in order to not exceed recommended SoC max T<sub>j</sub>.

## 7.2 DDR3 Board Design and Layout Guidelines

### 7.2.1 DDR3 General Board Layout Guidelines

To help ensure good signaling performance, consider the following board design guidelines:

- Avoid crossing splits in the power plane.
- Minimize Vref noise.
- Use the widest trace that is practical between decoupling capacitors and memory module.
- Maintain a single reference.
- Minimize ISI by keeping impedances matched.
- Minimize crosstalk by isolating sensitive bits, such as strobes, and avoiding return path discontinuities.
- Use proper low-pass filtering on the Vref pins.
- Keep the stub length as short as possible.
- Add additional spacing for on-clock and strobe nets to eliminate crosstalk.
- Maintain a common ground reference for all bypass and decoupling capacitors.
- Take into account the differences in propagation delays between microstrip and stripline nets when evaluating timing constraints.

### 7.2.2 DDR3 Board Design and Layout Guidelines

#### 7.2.2.1 Board Designs

TI only supports board designs using DDR3 memory that follow the guidelines in this document. The switching characteristics and timing diagram for the DDR3 memory controller are shown in [Table 7-2](#) and [Figure 7-1](#).

**Table 7-2. Switching Characteristics Over Recommended Operating Conditions for DDR3 Memory Controller**

NO.	PARAMETER		MIN	MAX	UNIT
RAM1	$t_{c(DDR\_CLK)}$	Cycle time, DDR_CLK	1.5	2.5 <sup>(1)</sup>	ns

(1) This is the absolute maximum the clock period can be. Actual maximum clock period may be limited by DDR3 speed grade and operating frequency (see the DDR3 memory device data sheet).

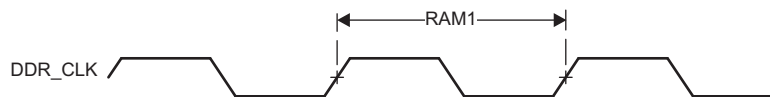

**Figure 7-1. DDR3 Memory Controller Clock Timing**

#### 7.2.2.2 DDR3 EMIFs

The processor contains two separate DDR3 EMIFs. This specification covers one of these EMIFs (ddr1\_\*) and, thus, needs to be implemented twice, once for each EMIF. The PCB layout generally turns out to be a semi-mirror with ddr2\_\* being a flipped version of ddr1\_\*; the only exception being the DDR3 devices themselves are not flipped unless mounted on opposite sides of the PCB. Requirements are identical between the two EMIFs.

### 7.2.2.3 DDR3 Device Combinations

Because there are several possible combinations of device counts and single- or dual-side mounting, [Table 7-3](#) summarizes the supported device configurations.

**Table 7-3. Supported DDR3 Device Combinations<sup>(1)</sup>**

NUMBER OF DDR3 DEVICES	DDR3 DATA DEVICE WIDTH (BITS)	MIRRORED?	DDR3 EMIF WIDTH (BITS)
1	16	N	16
2	8	Y <sup>(2)</sup>	16
2	16	N	32
2	16	Y <sup>(2)</sup>	32
3	16	N <sup>(4)</sup>	32
4	8	N	32
4	8	Y <sup>(3)</sup>	32
5	8	N <sup>(4)</sup>	32

(1) This table is per EMIF.

(2) Two DDR3 devices are mirrored when one device is placed on the top of the board and the second device is placed on the bottom of the board.

(3) This is two mirrored pairs of DDR3 devices.

(4) The DDR memory connected to the DDR ECC bus does NOT need to be the same part number as the DDR memories connected to the DDR data bus. However, some constraints do apply. When selecting a memory for the DDR ECC bus, the following restrictions must be adhered to as compared to the DDR memories on the data bus:

- Match the same DDR3 speed grade
- Have an equal number of internal banks
- Have an equal number of columns
- Have a greater or equal number of rows

### 7.2.2.4 DDR3 Interface Schematic

#### 7.2.2.4.1 32-Bit DDR3 Interface

The DDR3 interface schematic varies, depending upon the width of the DDR3 devices used and the width of the bus used (16 or 32 bits). General connectivity is straightforward and very similar. 16-bit DDR devices look like two 8-bit devices. [Figure 7-2](#) and [Figure 7-3](#) show the schematic connections for 32-bit interfaces using x16 devices.

#### 7.2.2.4.2 16-Bit DDR3 Interface

Note that the 16-bit wide interface schematic is practically identical to the 32-bit interface (see [Figure 7-2](#) and [Figure 7-3](#)); only the high-word DDR memories are removed and the unused DQS inputs are tied off.

When not using all or part of a DDR interface, the proper method of handling the unused pins is to tie off the `ddrx_dqsi` pins to ground via a 1-k $\Omega$  resistor and to tie off the `ddrx_dqsn` pins to the corresponding `vdds_ddrx` supply via a 1-k $\Omega$  resistor. This needs to be done for each byte not used. Although these signals have internal pullups and pulldowns, external pullups and pulldowns provide additional protection against external electrical noise causing activity on the signals.

The `vdds_ddrx` and `ddrx_vref0` power supply pins need to be connected to their respective power supplies even if `ddrx` is not being used. All other DDR interface pins can be left unconnected. Note that the supported modes for use of the DDR EMIF are 32-bits wide, 16-bits wide, or not used.

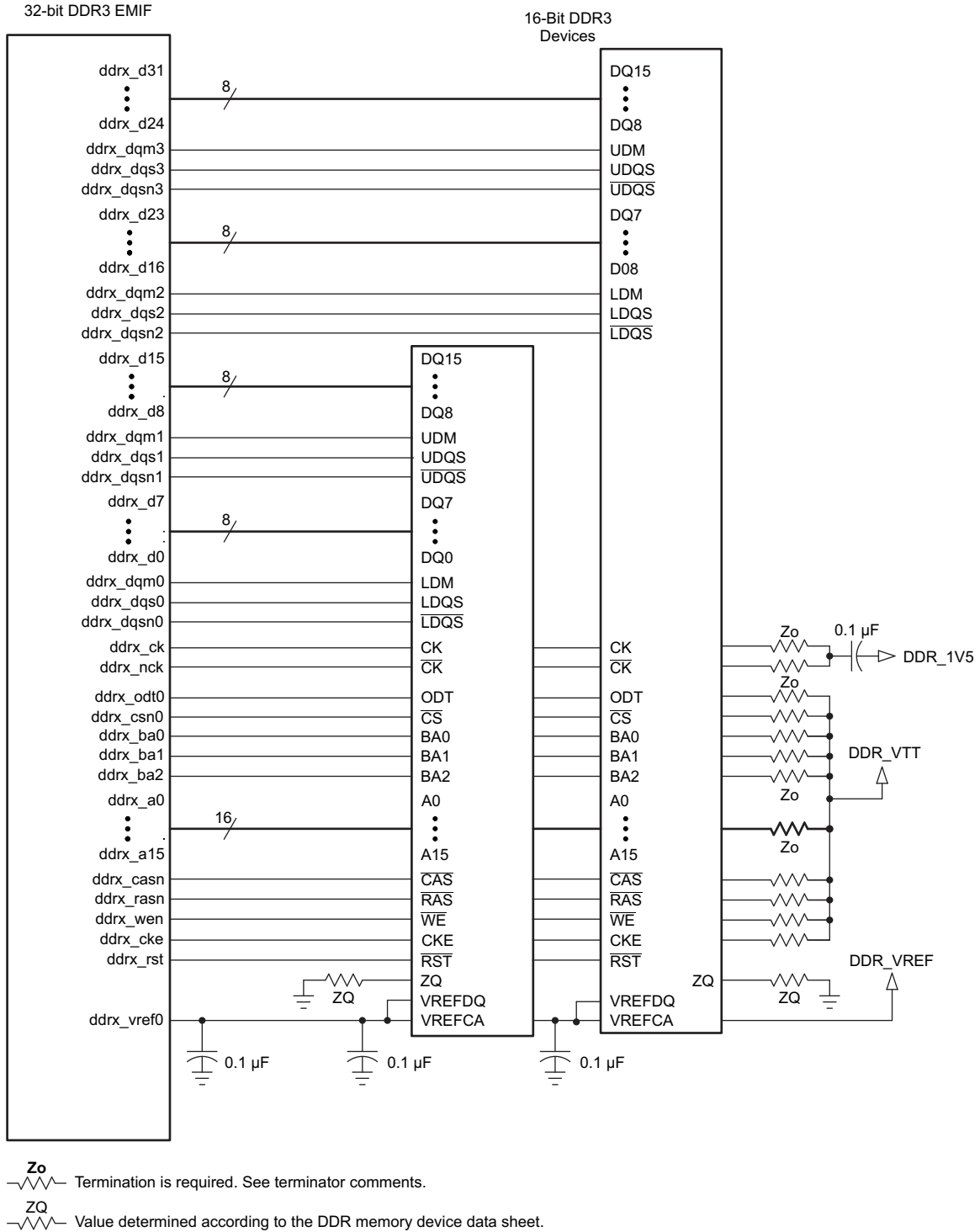

**Figure 7-2. 32-Bit, One-Bank DDR3 Interface Schematic Using Two 16-Bit DDR3 Devices**

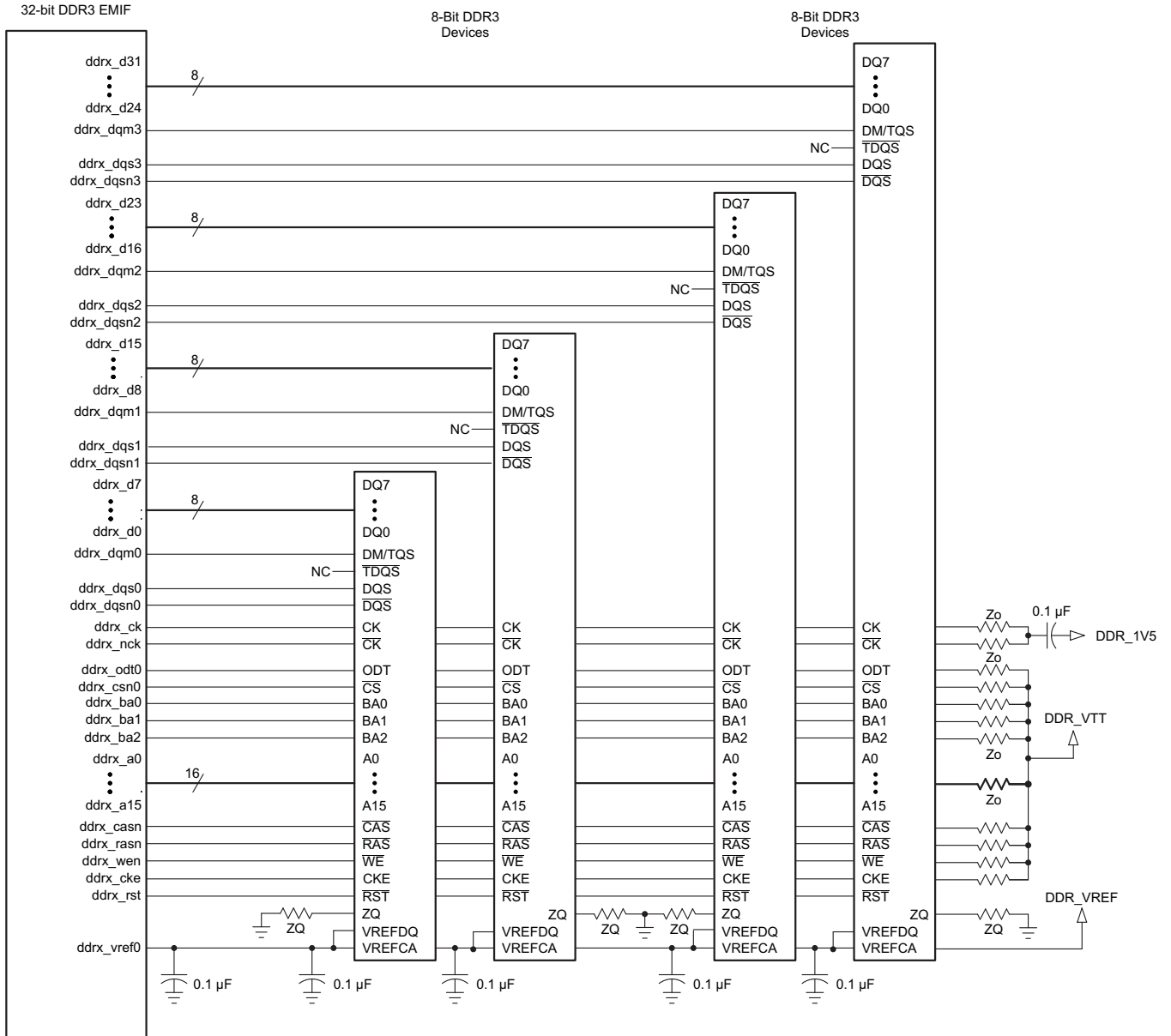

$Z_o$  Termination is required. See terminator comments.  
 $Z_Q$  Value determined according to the DDR memory device data sheet.

Figure 7-3. 32-Bit, One-Bank DDR3 Interface Schematic Using Four 8-Bit DDR3 Devices

### 7.2.2.5 Compatible JEDEC DDR3 Devices

Table 7-4 shows the parameters of the JEDEC DDR3 devices that are compatible with this interface. Generally, the DDR3 interface is compatible with DDR3-1333 devices in the x8 or x16 widths.

**Table 7-4. Compatible JEDEC DDR3 Devices (Per Interface)**

NO	PARAMETER	CONDITION	MIN	MAX	UNIT
1	JEDEC DDR3 device speed grade <sup>(1)</sup>	DDR clock rate = 400 MHz	DDR3-800	DDR3-1600	
		400 MHz < DDR clock rate ≤ 533 MHz	DDR3-1066	DDR3-1600	
		533 MHz < DDR clock rate ≤ 667 MHz	DDR3-1333	DDR3-1600	
2	JEDEC DDR3 device bit width		x8	x16	Bits
3	JEDEC DDR3 device count <sup>(2)</sup>		2	4	Devices

(1) Refer to Table 7-2, Switching Characteristics Over Recommended Operating Conditions for DDR3 Memory Controller for the range of supported DDR clock rates.

(2) For valid DDR3 device configurations and device counts, see Section 7.2.2.4, Figure 7-2, and Figure 7-3.

### 7.2.2.6 PCB Stackup

The minimum stackup for routing the DDR3 interface is a six-layer stack up as shown in Table 7-5. Additional layers may be added to the PCB stackup to accommodate other circuitry, enhance SI/EMI performance, or to reduce the size of the PCB footprint. Complete stackup specifications are provided in Table 7-6.

**Table 7-5. Six-Layer PCB Stackup Suggestion**

LAYER	TYPE	DESCRIPTION
1	Signal	Top routing mostly vertical
2	Plane	Ground
3	Plane	Split power plane
4	Plane	Split power plane or Internal routing
5	Plane	Ground
6	Signal	Bottom routing mostly horizontal



**Table 7-6. PCB Stackup Specifications**

NO.	PARAMETER	MIN	TYP	MAX	UNIT
PS1	PCB routing/plane layers	6			
PS2	Signal routing layers	3			
PS3	Full ground reference layers under DDR3 routing region <sup>(1)</sup>	1			
PS4	Full 1.5-V power reference layers under the DDR3 routing region <sup>(1)</sup>	1			
PS5	Number of reference plane cuts allowed within DDR routing region <sup>(2)</sup>			0	
PS6	Number of layers between DDR3 routing layer and reference plane <sup>(3)</sup>			0	
PS7	PCB routing feature size		4		Mils
PS8	PCB trace width, w		4		Mils
PS9	Single-ended impedance, $Z_0$	50		75	$\Omega$
PS10	Impedance control <sup>(5)</sup>	Z - 5	Z	Z + 5	$\Omega$

- (1) Ground reference layers are preferred over power reference layers. Be sure to include bypass caps to accommodate reference layer return current as the trace routes switch routing layers.
- (2) No traces should cross reference plane cuts within the DDR routing region. High speed signal traces crossing reference plane cuts create large return current paths which can lead to excessive crosstalk and EMI radiation.
- (3) Reference planes are to be directly adjacent to the signal plane to minimize the size of the return current loop.
- (4) An 18-mil pad assumes Via Channel is the most economical BGA escape. A 20-mil pad may be used if additional layers are available for power routing. An 18-mil pad is required for minimum layer count escape.
- (5) Z is the nominal singled-ended impedance selected for the PCB specified by PS9.

### 7.2.2.7 Placement

Figure 7-4 shows the required placement for the processor as well as the DDR3 devices. The dimensions for this figure are defined in Table 7-7. The placement does not restrict the side of the PCB on which the devices are mounted. The ultimate purpose of the placement is to limit the maximum trace lengths and allow for proper routing space. For a 16-bit DDR memory system, the high-word DDR3 devices are omitted from the placement.

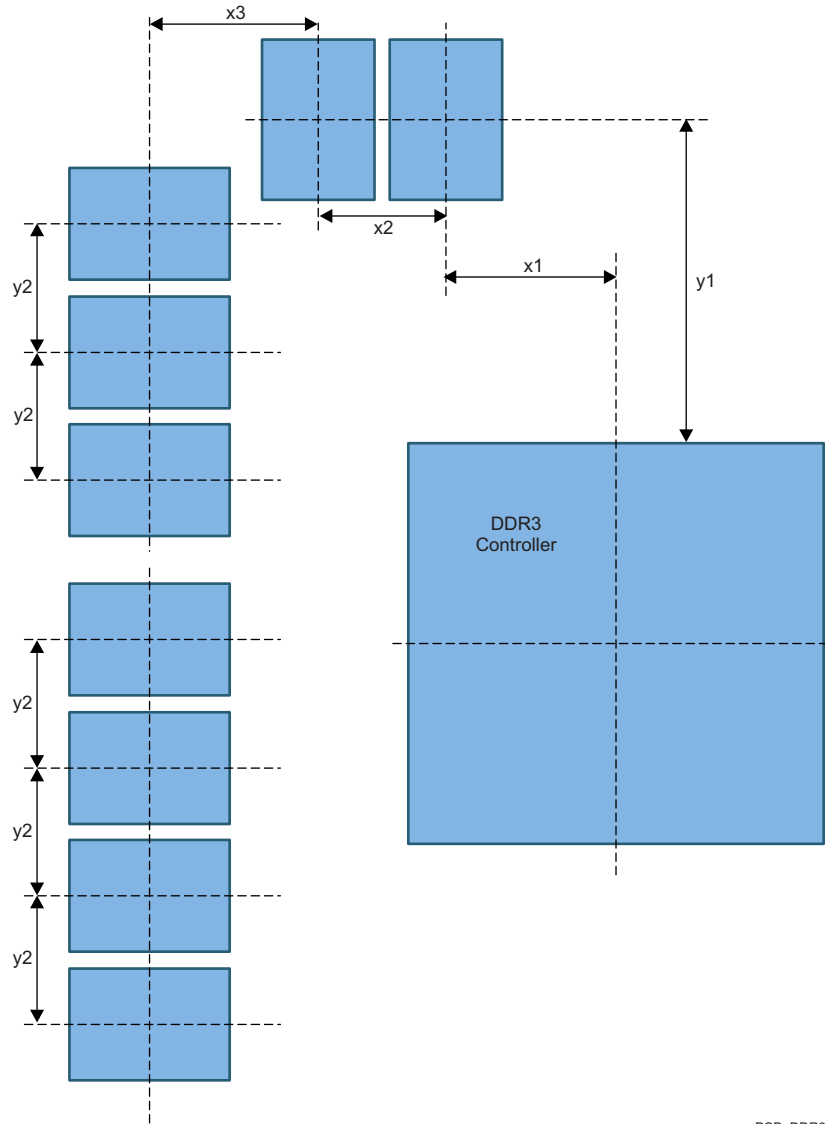

**Figure 7-4. Placement Specifications**

**Table 7-7. Placement Specifications DDR3**

NO.	PARAMETER	MIN	MAX	UNIT
KOD31	X1		500	Mils
KOD32	X2		600	Mils
KOD33	X3		600	Mils
KOD34	Y1		1800	Mils
KOD35	Y2		600	Mils
KOD36	DDR3 keepout region <sup>(1)</sup>			
KOD37	Clearance from non-DDR3 signal to DDR3 keepout region <sup>(2) (3)</sup>	4		W

- (1) DDR3 keepout region to encompass entire DDR3 routing area.
- (2) Non-DDR3 signals allowed within DDR3 keepout region provided they are separated from DDR3 routing layers by a ground plane.
- (3) If a device has more than one DDR controller, the signals from the other controller(s) are considered non-DDR3 and should be separated by this specification.

### 7.2.2.8 DDR3 Keepout Region

The region of the PCB used for DDR3 circuitry must be isolated from other signals. The DDR3 keepout region is defined for this purpose and is shown in [Figure 7-5](#). The size of this region varies with the placement and DDR routing. Additional clearances required for the keepout region are shown in [Table 7-7](#). Non-DDR3 signals should not be routed on the DDR signal layers within the DDR3 keepout region. Non-DDR3 signals may be routed in the region, provided they are routed on layers separated from the DDR signal layers by a ground layer. No breaks should be allowed in the reference ground layers in this region. In addition, the 1.5-V DDR3 power plane should cover the entire keepout region. Also note that the two signals from the DDR3 controller should be separated from each other by the specification in [Table 7-7](#) (see [KOD37](#)).

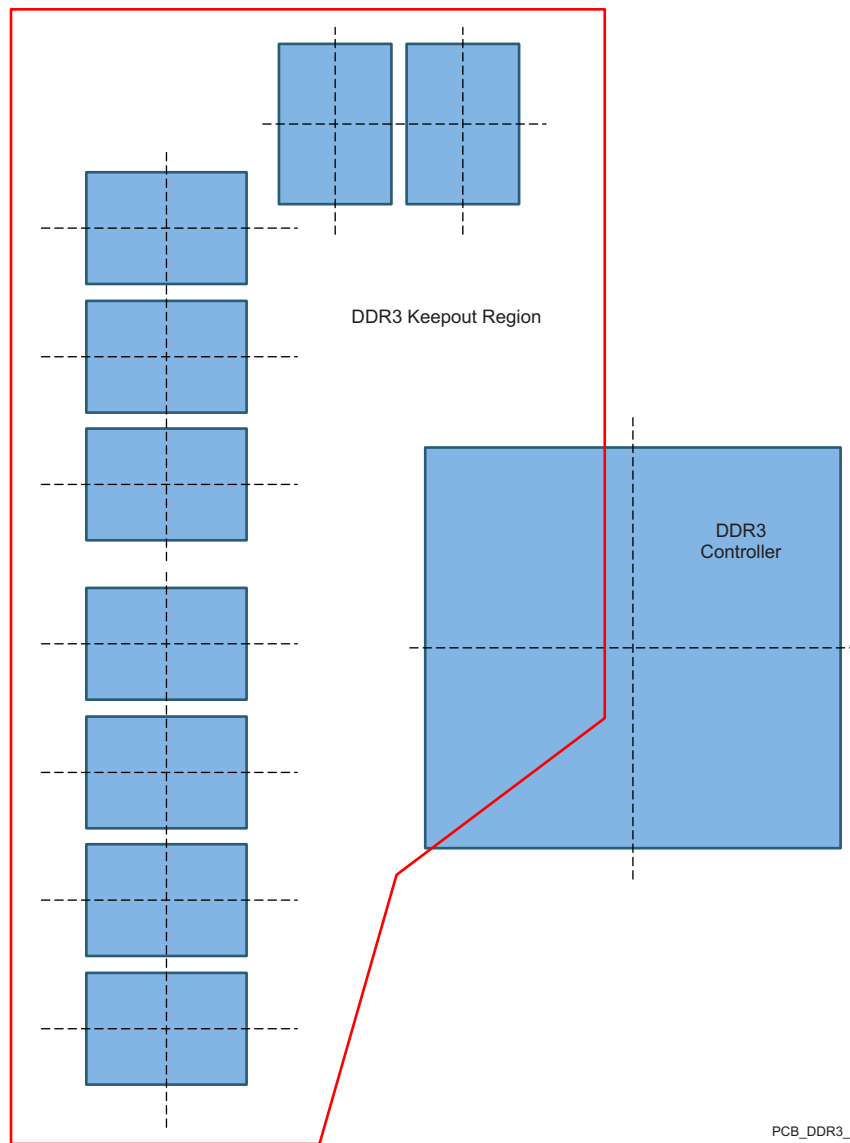

Figure 7-5. DDR3 Keepout Region

### 7.2.2.9 Bulk Bypass Capacitors

Bulk bypass capacitors are required for moderate speed bypassing of the DDR3 and other circuitry. [Table 7-8](#) contains the minimum numbers and capacitance required for the bulk bypass capacitors. Note that this table only covers the bypass needs of the DDR3 controllers and DDR3 devices. Additional bulk bypass capacitance may be needed for other circuitry.

**Table 7-8. Bulk Bypass Capacitors**

NO.	PARAMETER	MIN	MAX	UNIT
1	vdds_ddrx bulk bypass capacitor count <sup>(1)</sup>	1		Devices
2	vdds_ddrx bulk bypass total capacitance	22		μF

(1) These devices should be placed near the devices they are bypassing, but preference should be given to the placement of the High Speed (HS) bypass capacitors and DDR3 signal routing.

### 7.2.2.10 High Speed Bypass Capacitors

High Speed (HS) bypass capacitors are critical for proper DDR3 interface operation. It is particularly important to minimize the parasitic series inductance of the HS bypass capacitors, processor/DDR power, and processor/DDR ground connections. [Table 7-9](#) contains the specification for the HS bypass capacitors as well as for the power connections on the PCB. Generally speaking, it is good to:

1. Fit as many HS bypass capacitors as possible.
2. Minimize the distance from the bypass cap to the pins/balls being bypassed.
3. Use the smallest physical sized capacitors possible with the highest capacitance readily available.
4. Connect the bypass capacitor pads to their vias using the widest traces possible and using the largest hole size via possible.
5. Minimize via sharing. Note the limites on via sharing shown in [Table 7-9](#).

**Table 7-9. High Speed Bypass Capacitors**

NO.	PARAMETER	MIN	TYP	MAX	UNIT
1	HS bypass capacitor package size <sup>(1)</sup>		0201	0402	10 Mils
2	Distance, HS bypass capacitor to processor being bypassed <sup>(2)(3)(4)</sup>			400	Mils
3	Processor HS bypass capacitor count per vdds_ddrx rail		See <a href="#">Section 7.4</a> and <sup>(11)</sup>		Devices
4	Processor HS bypass capacitor total capacitance per vdds_ddrx rail		See <a href="#">Section 7.4</a> and <sup>(11)</sup>		μF
5	Number of connection vias for each device power/ground ball <sup>(5)</sup>				Vias
6	Trace length from device power/ground ball to connection via <sup>(2)</sup>		35	70	Mils
7	Distance, HS bypass capacitor to DDR device being bypassed <sup>(6)</sup>			150	Mils
8	DDR3 device HS bypass capacitor count <sup>(7)</sup>	12			Devices
9	DDR3 device HS bypass capacitor total capacitance <sup>(7)</sup>	0.85			μF
10	Number of connection vias for each HS capacitor <sup>(8)(9)</sup>	2			Vias
11	Trace length from bypass capacitor connect to connection via <sup>(2)(9)</sup>		35	100	Mils
12	Number of connection vias for each DDR3 device power/ground ball <sup>(10)</sup>	1			Vias
13	Trace length from DDR3 device power/ground ball to connection via <sup>(2)(8)</sup>		35	60	Mils

(1) LxW, 10-mil units, that is, a 0402 is a 40x20-mil surface-mount capacitor.

(2) Closer/shorter is better.

(3) Measured from the nearest processor power/ground ball to the center of the capacitor package.

(4) Three of these capacitors should be located underneath the processor, between the cluster of DDR\_1V5 balls and ground balls, between the DDR interfaces on the package.

(5) See the Via Channel™ escape for the processor package.

(6) Measured from the DDR3 device power/ground ball to the center of the capacitor package.

(7) Per DDR3 device.

(8) An additional HS bypass capacitor can share the connection vias only if it is mounted on the opposite side of the board. No sharing of vias is permitted on the same side of the board.

- (9) An HS bypass capacitor may share a via with a DDR device mounted on the same side of the PCB. A wide trace should be used for the connection and the length from the capacitor pad to the DDR device pad should be less than 150 mils.
- (10) Up to a total of two pairs of DDR power/ground balls may share a via.
- (11) The capacitor recommendations in this Data Manual reflect only the needs of this processor. Please see the memory vendor's guidelines for determining the appropriate decoupling capacitor arrangement for the memory device itself.

### 7.2.2.10.1 Return Current Bypass Capacitors

Use additional bypass capacitors if the return current reference plane changes due to DDR3 signals hopping from one signal layer to another. The bypass capacitor here provides a path for the return current to hop planes along with the signal. As many of these return current bypass capacitors should be used as possible. Because these are returns for signal current, the signal via size may be used for these capacitors.

### 7.2.2.11 Net Classes

[Table 7-10](#) lists the clock net classes for the DDR3 interface. [Table 7-11](#) lists the signal net classes, and associated clock net classes, for signals in the DDR3 interface. These net classes are used for the termination and routing rules that follow.

**Table 7-10. Clock Net Class Definitions**

CLOCK NET CLASS	PROCESSOR PIN NAMES
CK	ddrx_ck / ddrx_nck
DQS0	ddrx_dqs0 / ddrx_dqsn0
DQS1	ddrx_dqs1 / ddrx_dqsn1
DQS2 <sup>(1)</sup>	ddrx_dqs2 / ddrx_dqsn2
DQS3 <sup>(1)</sup>	ddrx_dqs3 / ddrx_dqsn3

(1) Only used on 32-bit wide DDR3 memory systems.

**Table 7-11. Signal Net Class Definitions**

SIGNAL NET CLASS	ASSOCIATED CLOCK NET CLASS	PROCESSOR PIN NAMES
ADDR_CTRL	CK	ddrx_ba[2:0], ddrx_a[14:0], ddrx_csnj, ddrx_casn, ddrx_rasn, ddrx_wen, ddrx_cke, ddrx_odti
DQ0	DQS0	ddrx_d[7:0], ddrx_dqm0
DQ1	DQS1	ddrx_d[15:8], ddrx_dqm1
DQ2 <sup>(1)</sup>	DQS2	ddrx_d[23:16], ddrx_dqm2
DQ3 <sup>(1)</sup>	DQS3	ddrx_d[31:24], ddrx_dqm3

(1) Only used on 32-bit wide DDR3 memory systems.

### 7.2.2.12 DDR3 Signal Termination

Signal terminators are required for the CK and ADDR\_CTRL net classes. The data lines are terminated by ODT and, thus, the PCB traces should be unterminated. Detailed termination specifications are covered in the routing rules in the following sections.

### 7.2.2.13 VREF\_DDR Routing

ddrx\_vref0 (VREF) is used as a reference by the input buffers of the DDR3 memories as well as the processor. VREF is intended to be half the DDR3 power supply voltage and is typically generated with the DDR3 VDD5 and VTT power supply. It should be routed as a nominal 20-mil wide trace with 0.1  $\mu$ F bypass capacitors near each device connection. Narrowing of VREF is allowed to accommodate routing congestion.

### 7.2.2.14 VTT

Like VREF, the nominal value of the VTT supply is half the DDR3 supply voltage. Unlike VREF, VTT is expected to source and sink current, specifically the termination current for the ADDR\_CTRL net class Thevenin terminators. VTT is needed at the end of the address bus and it should be routed as a power sub-plane. VTT should be bypassed near the terminator resistors.

### 7.2.2.15 CK and ADDR\_CTRL Topologies and Routing Definition

The CK and ADDR\_CTRL net classes are routed in a fly-by topology. They are routed in a similar manner and are length matched to minimize skew between them. CK is a bit more complicated because it runs at a higher transition rate and is differential. The following subsections show the topology and routing for various DDR3 configurations for CK and ADDR\_CTRL. The figures in the following subsections define the terms for the routing specification detailed in [Table 7-12](#). Balanced-T routing is not recommended.

#### 7.2.2.15.1 Four DDR3 Devices

Four DDR3 devices are supported on the DDR EMIF consisting of four x8 DDR3 devices arranged as one bank (CS). These four devices may be mounted on a single side of the PCB, or may be mirrored in two pairs to save board space at a cost of increased routing complexity and parts on the backside of the PCB.

##### 7.2.2.15.1.1 CK and ADDR\_CTRL Topologies, Four DDR3 Devices

[Figure 7-6](#) shows the topology of the CK net classes and [Figure 7-7](#) shows the topology for the corresponding ADDR\_CTRL net classes.

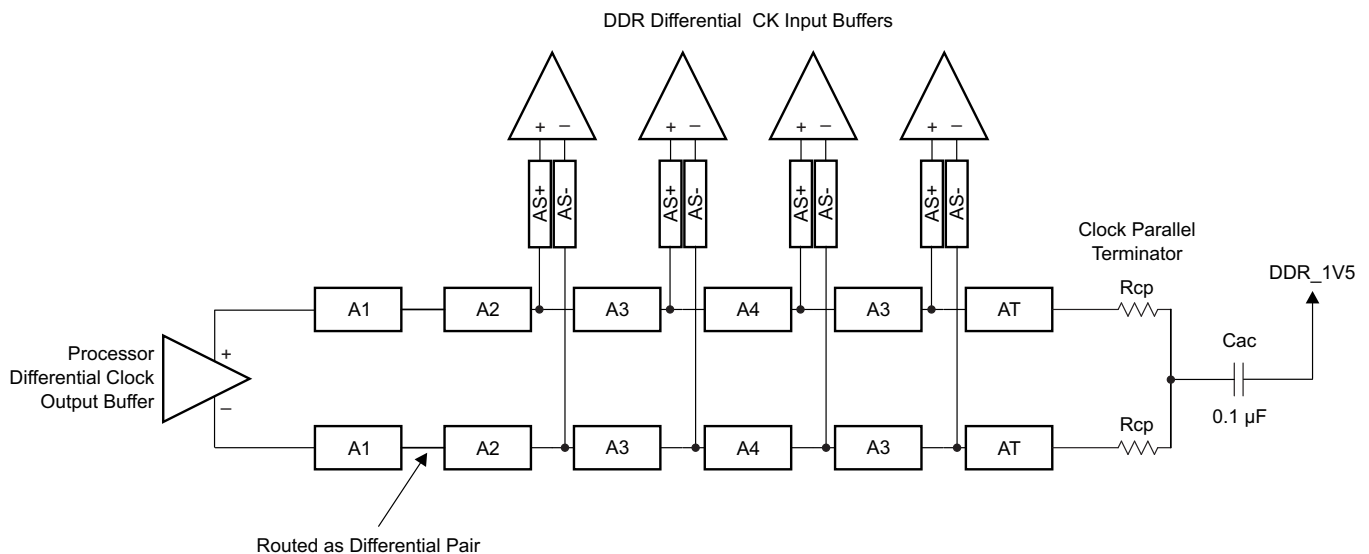

**Figure 7-6. CK Topology for Four x8 DDR3 Devices**

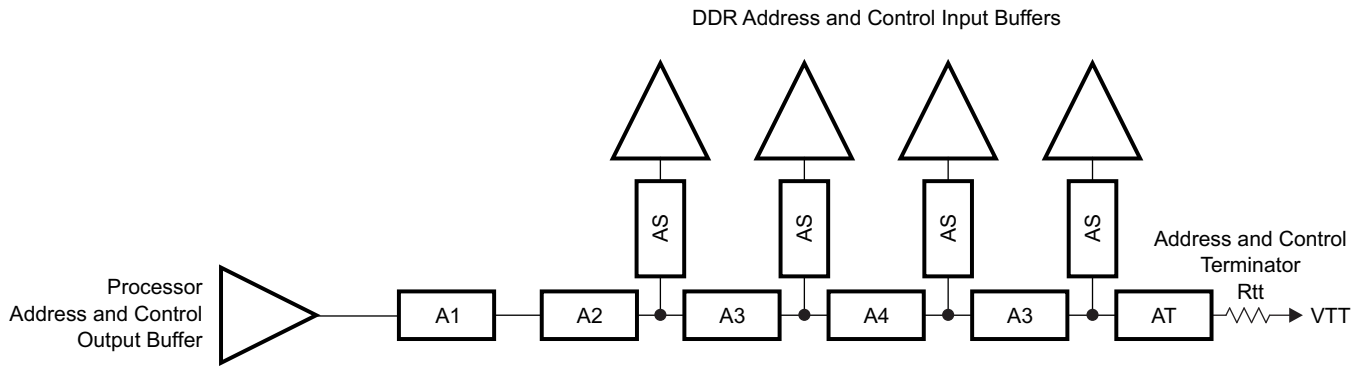

Figure 7-7. ADDR\_CTRL Topology for Four x8 DDR3 Devices

7.2.2.15.1.2 CK and ADDR\_CTRL Routing, Four DDR3 Devices

Figure 7-8 shows the CK routing for four DDR3 devices placed on the same side of the PCB. Figure 7-9 shows the corresponding ADDR\_CTRL routing.

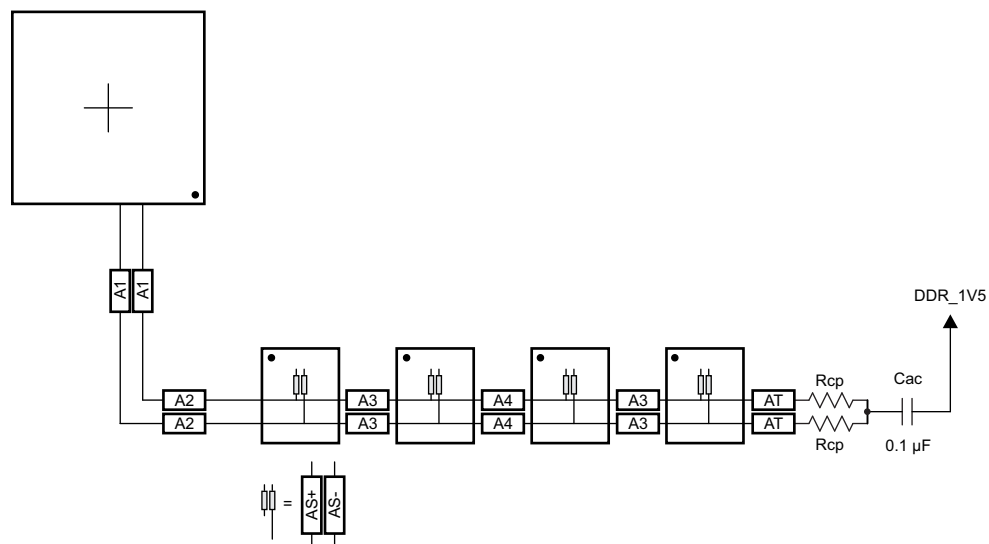
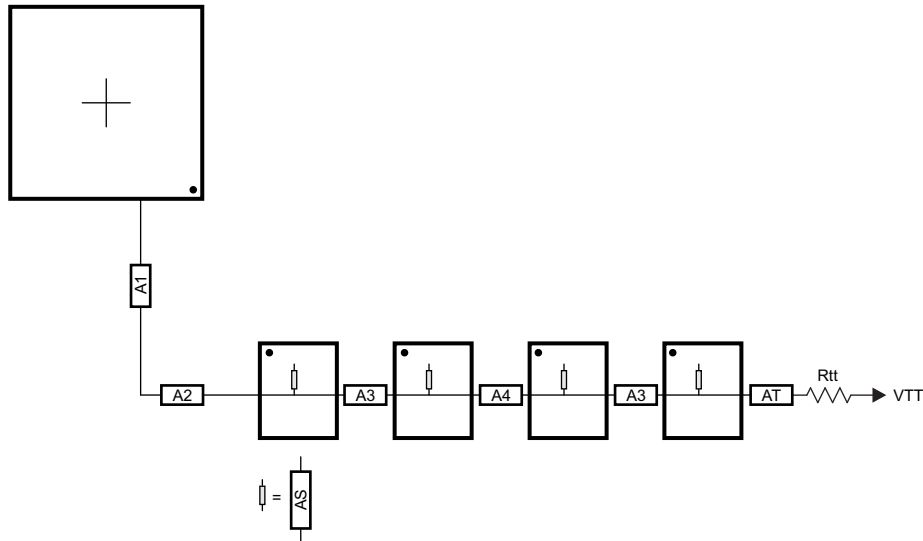
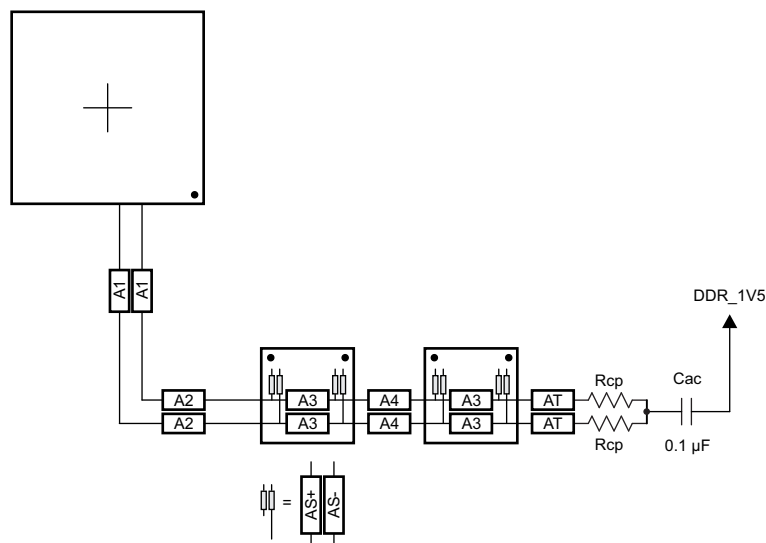

Figure 7-8. CK Routing for Four Single-Side DDR3 Devices



**Figure 7-9. ADDR\_CTRL Routing for Four Single-Side DDR3 Devices**

To save PCB space, the four DDR3 memories may be mounted as two mirrored pairs at a cost of increased routing and assembly complexity. [Figure 7-10](#) and [Figure 7-11](#) show the routing for CK and ADDR\_CTRL, respectively, for four DDR3 devices mirrored in a two-pair configuration.



**Figure 7-10. CK Routing for Four Mirrored DDR3 Devices**



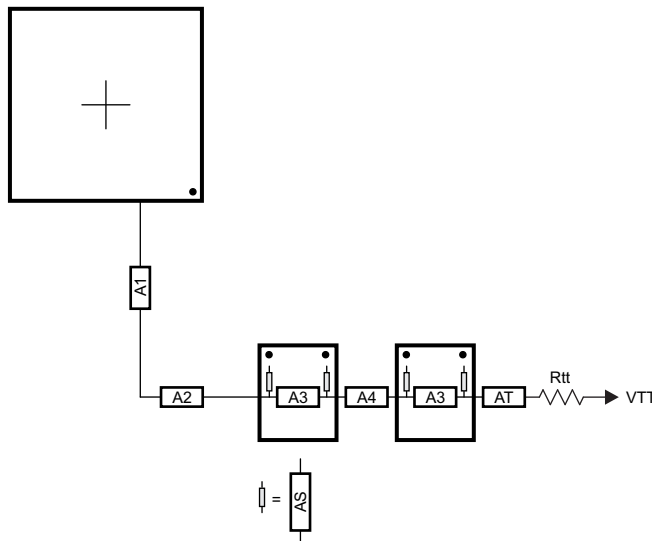

Figure 7-11. ADDR\_CTRL Routing for Four Mirrored DDR3 Devices

7.2.2.15.2 Two DDR3 Devices

Two DDR3 devices are supported on the DDR EMIF consisting of two x8 DDR3 devices arranged as one bank (CS), 16 bits wide, or two x16 DDR3 devices arranged as one bank (CS), 32 bits wide. These two devices may be mounted on a single side of the PCB, or may be mirrored in a pair to save board space at a cost of increased routing complexity and parts on the backside of the PCB.

7.2.2.15.2.1 CK and ADDR\_CTRL Topologies, Two DDR3 Devices

Figure 7-12 shows the topology of the CK net classes and Figure 7-13 shows the topology for the corresponding ADDR\_CTRL net classes.

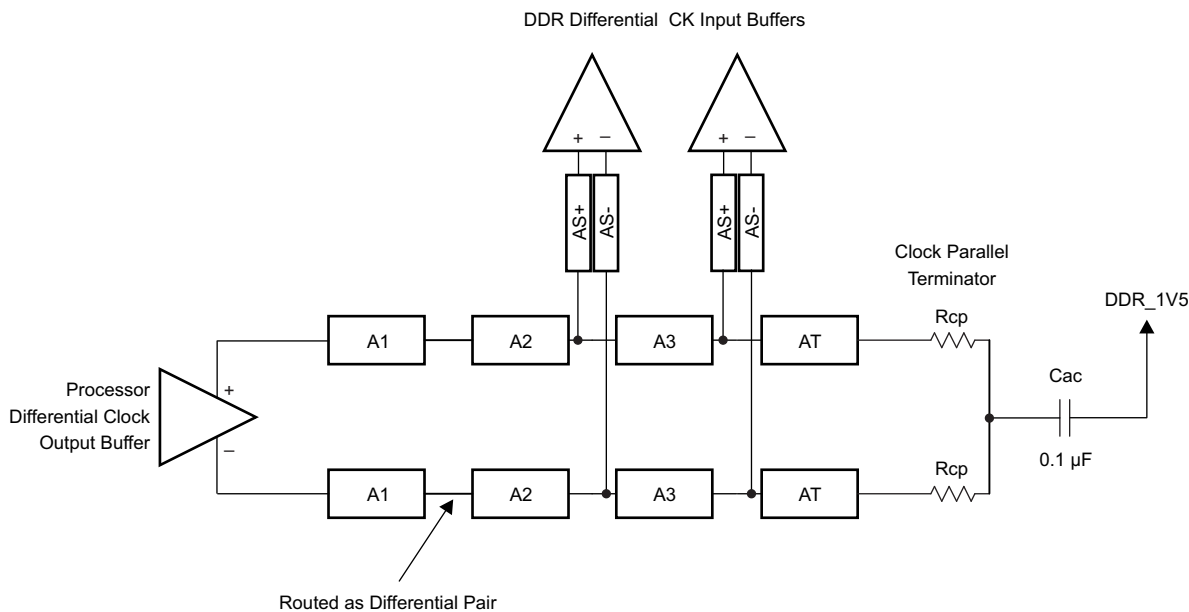

Figure 7-12. CK Topology for Two DDR3 Devices

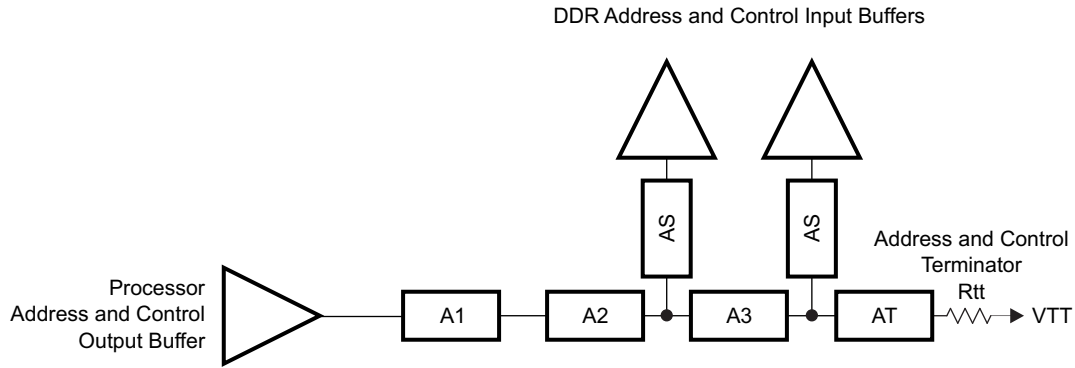

Figure 7-13. ADDR\_CTRL Topology for Two DDR3 Devices

7.2.2.15.2.2 CK and ADDR\_CTRL Routing, Two DDR3 Devices

Figure 7-14 shows the CK routing for two DDR3 devices placed on the same side of the PCB. Figure 7-15 shows the corresponding ADDR\_CTRL routing.

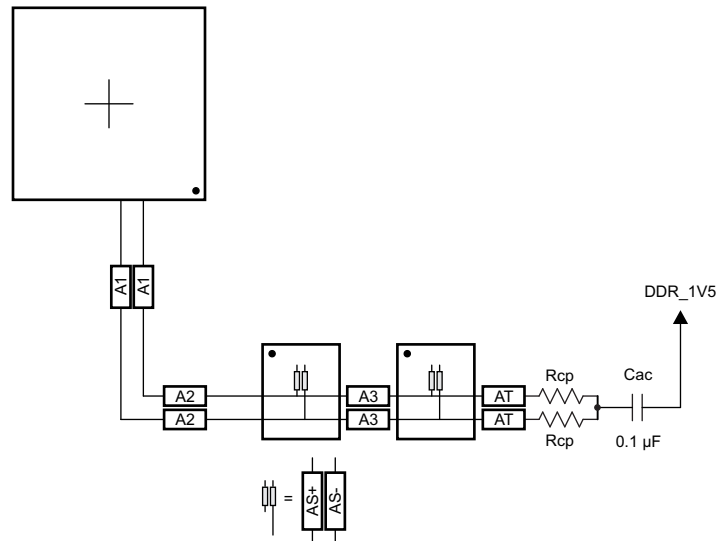
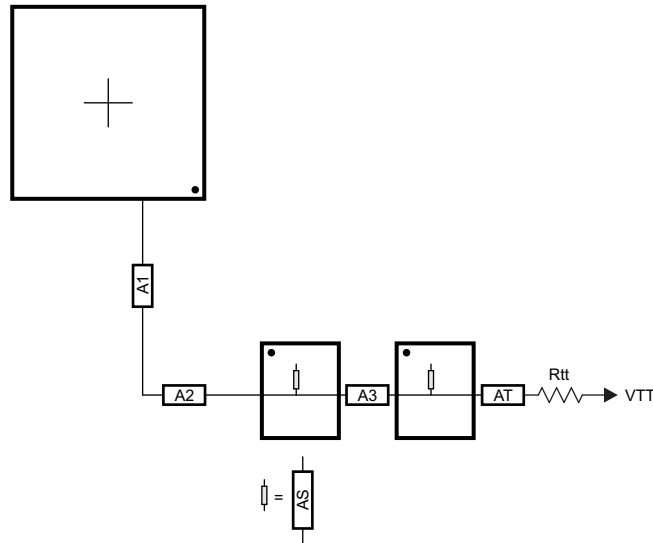
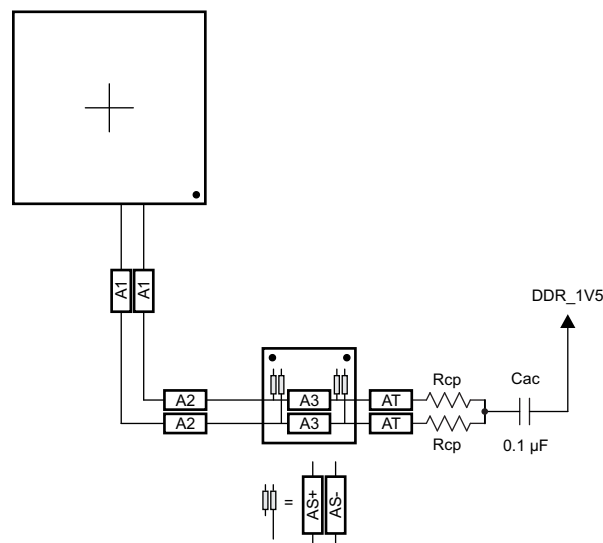

Figure 7-14. CK Routing for Two Single-Side DDR3 Devices



**Figure 7-15. ADDR\_CTRL Routing for Two Single-Side DDR3 Devices**

To save PCB space, the two DDR3 memories may be mounted as a mirrored pair at a cost of increased routing and assembly complexity. Figure 7-16 and Figure 7-17 show the routing for CK and ADDR\_CTRL, respectively, for two DDR3 devices mirrored in a single-pair configuration.



**Figure 7-16. CK Routing for Two Mirrored DDR3 Devices**

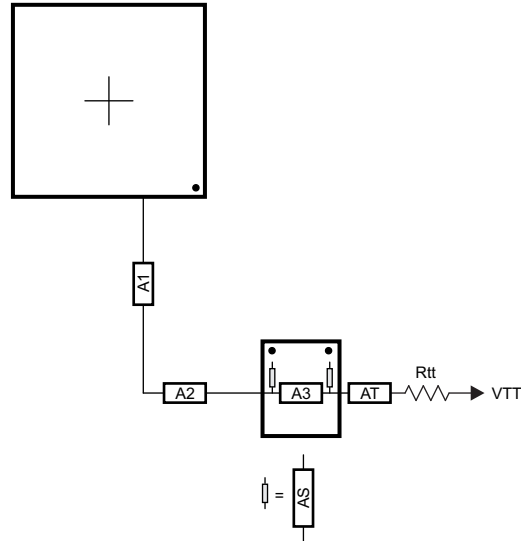

Figure 7-17. ADDR\_CTRL Routing for Two Mirrored DDR3 Devices

7.2.2.15.3 One DDR3 Device

A single DDR3 device is supported on the DDR EMIF consisting of one x16 DDR3 device arranged as one bank (CS), 16 bits wide.

7.2.2.15.3.1 CK and ADDR\_CTRL Topologies, One DDR3 Device

Figure 7-18 shows the topology of the CK net classes and Figure 7-19 shows the topology for the corresponding ADDR\_CTRL net classes.

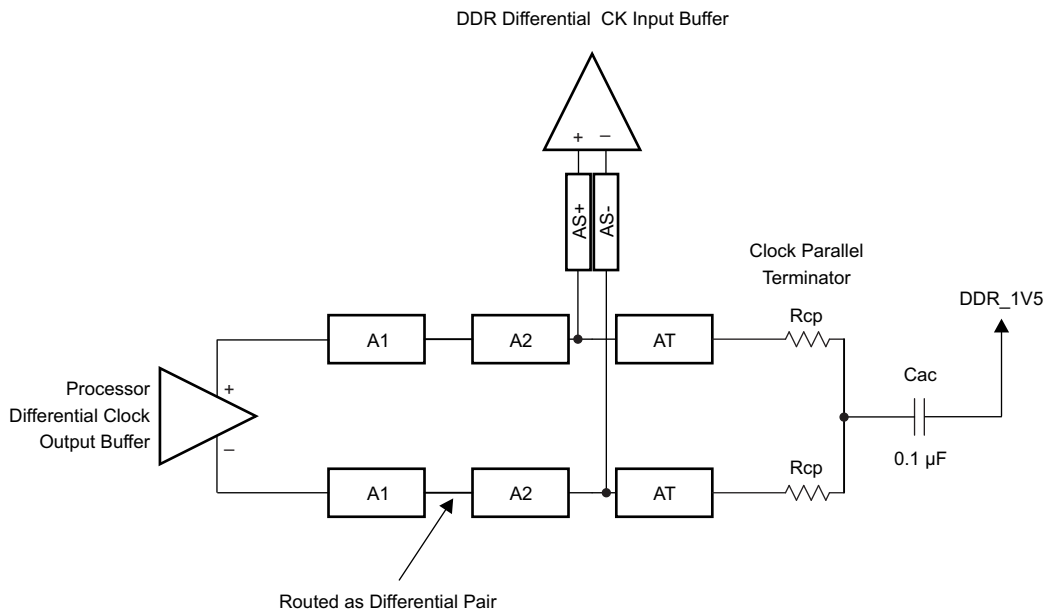

Figure 7-18. CK Topology for One DDR3 Device

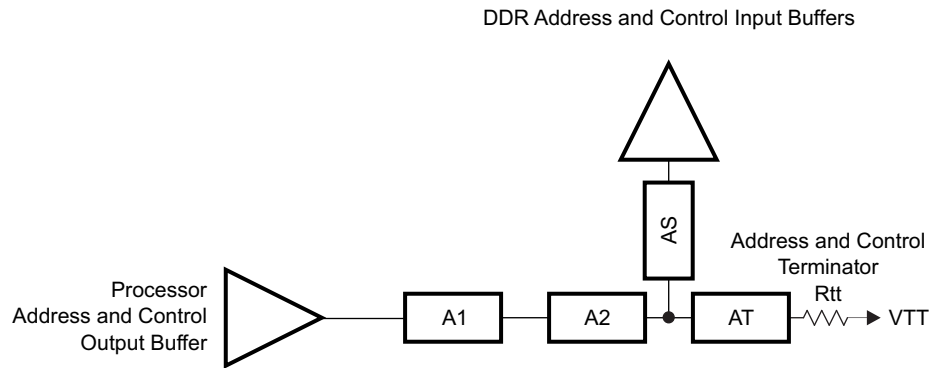

Figure 7-19. ADDR\_CTRL Topology for One DDR3 Device

### 7.2.2.15.3.2 CK and ADDR/CTRL Routing, One DDR3 Device

Figure 7-20 shows the CK routing for one DDR3 device placed on the same side of the PCB. Figure 7-21 shows the corresponding ADDR\_CTRL routing.

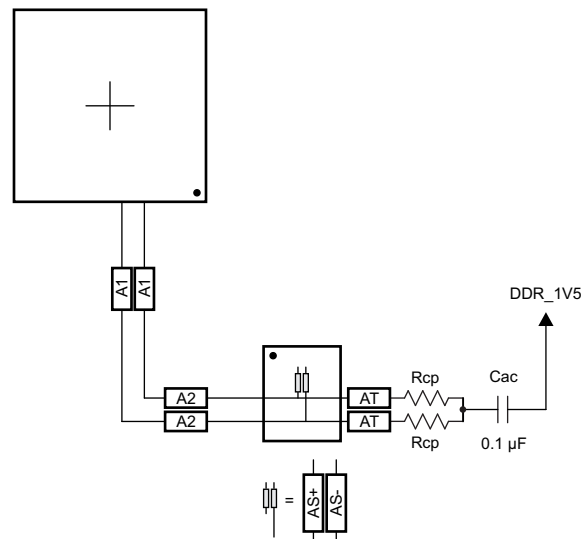

Figure 7-20. CK Routing for One DDR3 Device

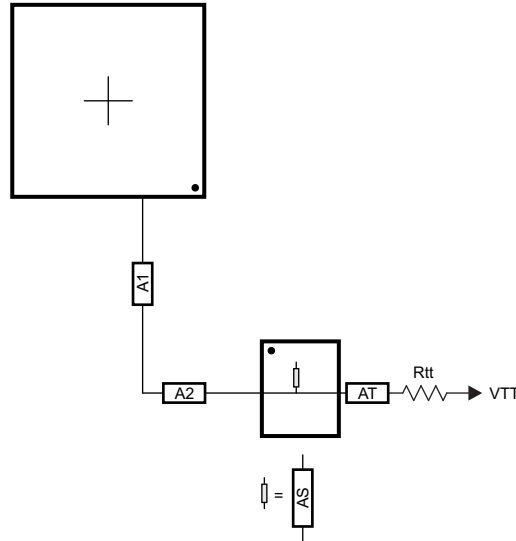

Figure 7-21. ADDR\_CTRL Routing for One DDR3 Device

7.2.2.16 Data Topologies and Routing Definition

No matter the number of DDR3 devices used, the data line topology is always point to point, so its definition is simple.

Care should be taken to minimize layer transitions during routing. If a layer transition is necessary, it is better to transition to a layer using the same reference plane. If this cannot be accommodated, ensure there are nearby ground vias to allow the return currents to transition between reference planes if both reference planes are ground or vdds\_ddr. Ensure there are nearby bypass capacitors to allow the return currents to transition between reference planes if one of the reference planes is ground. The goal is to minimize the size of the return current loops.

7.2.2.16.1 DQS and DQ/DM Topologies, Any Number of Allowed DDR3 Devices

DQS lines are point-to-point differential, and DQ/DM lines are point-to-point singled ended. Figure 7-22 and Figure 7-23 show these topologies.

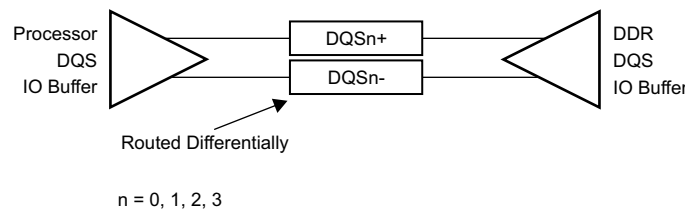

Figure 7-22. DQS Topology

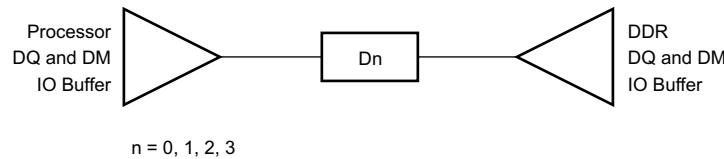

Figure 7-23. DQ/DM Topology

7.2.2.16.2 DQS and DQ/DM Routing, Any Number of Allowed DDR3 Devices

Figure 7-24 and Figure 7-25 show the DQS and DQ/DM routing.

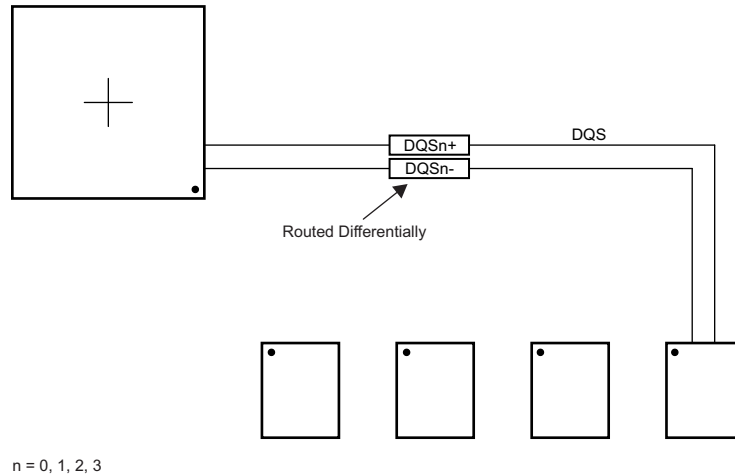

Figure 7-24. DQS Routing With Any Number of Allowed DDR3 Devices

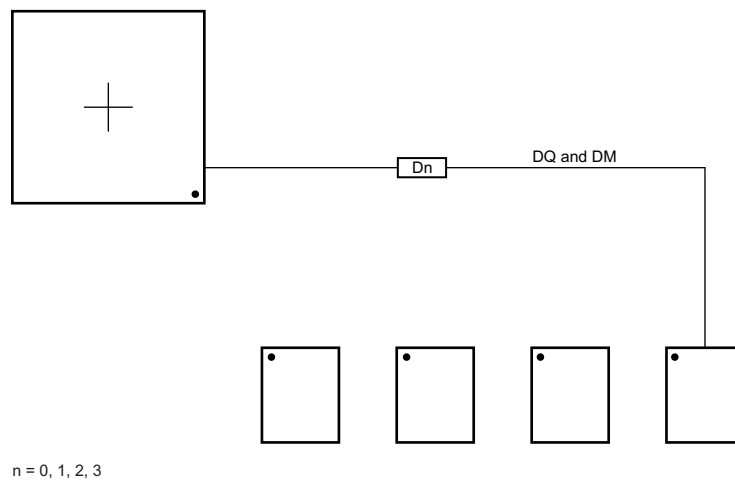

Figure 7-25. DQ/DM Routing With Any Number of Allowed DDR3 Devices

### 7.2.2.17 Routing Specification

#### 7.2.2.17.1 CK and ADDR\_CTRL Routing Specification

Skew within the CK and ADDR\_CTRL net classes directly reduces setup and hold margin and, thus, this skew must be controlled. The only way to practically match lengths on a PCB is to lengthen the shorter traces up to the length of the longest net in the net class and its associated clock. A metric to establish this maximum length is Manhattan distance. The Manhattan distance between two points on a PCB is the length between the points when connecting them only with horizontal or vertical segments. A reasonable trace route length is to within a percentage of its Manhattan distance. CACLM is defined as Clock Address Control Longest Manhattan distance.

Given the clock and address pin locations on the processor and the DDR3 memories, the maximum possible Manhattan distance can be determined given the placement. Figure 7-26 and Figure 7-27 show this distance for four loads and two loads, respectively. It is from this distance that the specifications on the lengths of the transmission lines for the address bus are determined. CACLM is determined similarly for other address bus configurations; that is, it is based on the longest net of the CK/ADDR\_CTRL net class. For CK and ADDR\_CTRL routing, these specifications are contained in Table 7-12.

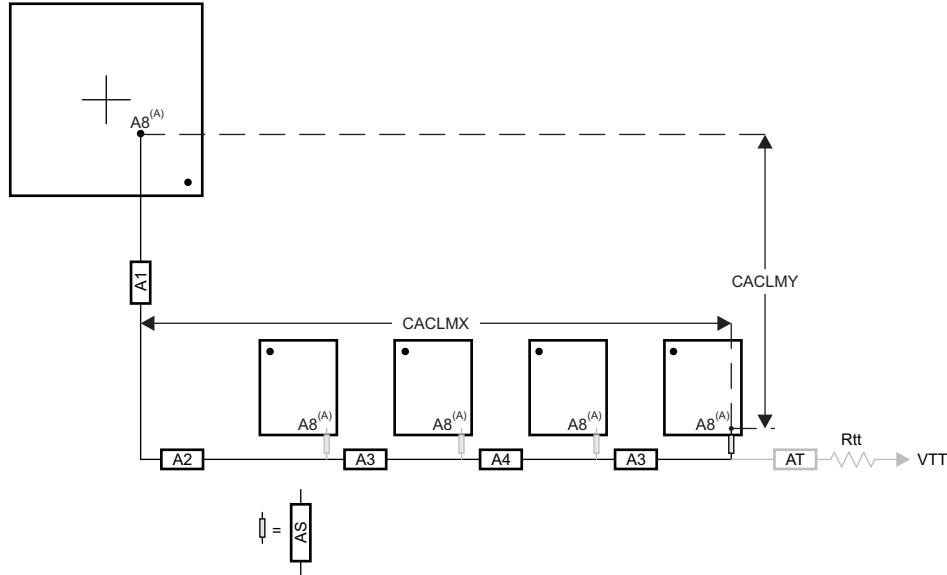

- A. It is very likely that the longest CK/ADDR\_CTRL Manhattan distance will be for Address Input 8 (A8) on the DDR3 memories. CACLML is based on the longest Manhattan distance due to the device placement. Verify the net class that satisfies this criteria and use as the baseline for CK/ADDR\_CTRL skew matching and length control.

The length of shorter CK/ADDR\_CTRL stubs as well as the length of the terminator stub are not included in this length calculation. Nonincluded lengths are grayed out in the figure.

Assuming A8 is the longest, CACLML = CACLMY + CACLMX + 300 mils.  
The extra 300 mils allows for routing down lower than the DDR3 memories and returning up to reach A8.

**Figure 7-26. CACLML for Four Address Loads on One Side of PCB**

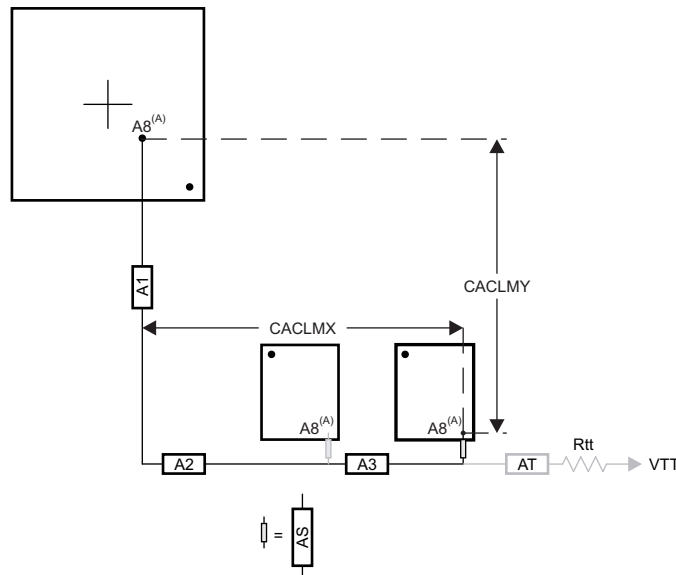

- A. It is very likely that the longest CK/ADDR\_CTRL Manhattan distance will be for Address Input 8 (A8) on the DDR3 memories. CACLML is based on the longest Manhattan distance due to the device placement. Verify the net class that satisfies this criteria and use as the baseline for CK/ADDR\_CTRL skew matching and length control.

The length of shorter CK/ADDR\_CTRL stubs as well as the length of the terminator stub are not included in this length calculation. Nonincluded lengths are grayed out in the figure.

Assuming A8 is the longest, CACLML = CACLMY + CACLMX + 300 mils.  
The extra 300 mils allows for routing down lower than the DDR3 memories and returning up to reach A8.

**Figure 7-27. CACLML for Two Address Loads on One Side of PCB**



**Table 7-12. CK and ADDR\_CTRL Routing Specification<sup>(2)(3)</sup>**

NO.	PARAMETER	MIN	TYP	MAX	UNIT
CARS31	A1+A2 length			500 <sup>(1)</sup>	ps
CARS32	A1+A2 skew			29	ps
CARS33	A3 length			125	ps
CARS34	A3 skew <sup>(4)</sup>			6	ps
CARS35	A3 skew <sup>(5)</sup>			6	ps
CARS36	A4 length			125	ps
CARS37	A4 skew			6	ps
CARS38	AS length		5	17 <sup>(1)</sup>	ps
CARS39	AS skew		1.3	14 <sup>(1)</sup>	ps
CARS310	AS+/AS- length		5	12	ps
CARS311	AS+/AS- skew			1	ps
CARS312	AT length <sup>(6)</sup>		75		ps
CARS313	AT skew <sup>(7)</sup>		14		ps
CARS314	AT skew <sup>(8)</sup>			1	ps
CARS315	CK/ADDR_CTRL trace length			1020	ps
CARS316	Vias per trace			3 <sup>(1)</sup>	vias
CARS317	Via count difference			1 <sup>(15)</sup>	vias
CARS318	Center-to-center CK to other DDR3 trace spacing <sup>(9)</sup>	4w			
CARS319	Center-to-center ADDR_CTRL to other DDR3 trace spacing <sup>(9)(10)</sup>	4w			
CARS320	Center-to-center ADDR_CTRL to other ADDR_CTRL trace spacing <sup>(9)</sup>	3w			
CARS321	CK center-to-center spacing <sup>(11)(12)</sup>				
CARS322	CK spacing to other net <sup>(9)</sup>	4w			
CARS323	Rcp <sup>(13)</sup>	Zo - 1	Zo	Zo + 1	Ω
CARS324	Rtt <sup>(13)(14)</sup>	Zo - 5	Zo	Zo + 5	Ω

(1) Max value is based upon conservative signal integrity approach. This value could be extended only if detailed signal integrity analysis of rise time and fall time confirms desired operation.

(2) The use of vias should be minimized.

(3) Additional bypass capacitors are required when using the DDR\_1V5 plane as the reference plane to allow the return current to jump between the DDR\_1V5 plane and the ground plane when the net class switches layers at a via.

(4) Non-mirrored configuration (all DDR3 memories on same side of PCB).

(5) Mirrored configuration (one DDR3 device on top of the board and one DDR3 device on the bottom).

(6) While this length can be increased for convenience, its length should be minimized.

(7) ADDR\_CTRL net class only (not CK net class). Minimizing this skew is recommended, but not required.

(8) CK net class only.

(9) Center-to-center spacing is allowed to fall to minimum 2w for up to 1250 mils of routed length.

(10) The ADDR\_CTRL net class of the other DDR EMIF is considered *other DDR3 trace spacing*.

(11) CK spacing set to ensure proper differential impedance.

(12) The most important thing to do is control the impedance so inadvertent impedance mismatches are not created. Generally speaking, center-to-center spacing should be either 2w or slightly larger than 2w to achieve a differential impedance equal to twice the singleended impedance, Zo.

(13) Source termination (series resistor at driver) is specifically not allowed.

(14) Termination values should be uniform across the net class.

(15) Via count difference may increase by 1 only if accurate 3-D modeling of the signal flight times – including accurately modeled signal propagation through vias – has been applied to ensure all segment skew maximums are not exceeded.

**7.2.2.17.2 DQS and DQ Routing Specification**

Skew within the DQS and DQ/DM net classes directly reduces setup and hold margin and thus this skew must be controlled. The only way to practically match lengths on a PCB is to lengthen the shorter traces up to the length of the longest net in the net class and its associated clock. As with CK and ADDR\_CTRL, a reasonable trace route length is to within a percentage of its Manhattan distance. DQLMn is defined as DQ Longest Manhattan distance n, where n is the byte number. For a 32-bit interface, there are four DQLMs, DQLM0-DQLM3. Likewise, for a 16-bit interface, there are two DQLMs, DQLM0-DQLM1.

**NOTE**

It is not required, nor is it recommended, to match the lengths across all bytes. Length matching is only required within each byte.

Given the DQS and DQ/DM pin locations on the processor and the DDR3 memories, the maximum possible Manhattan distance can be determined given the placement. Figure 7-28 shows this distance for four loads. It is from this distance that the specifications on the lengths of the transmission lines for the data bus are determined. For DQS and DQ/DM routing, these specifications are contained in Table 7-13.

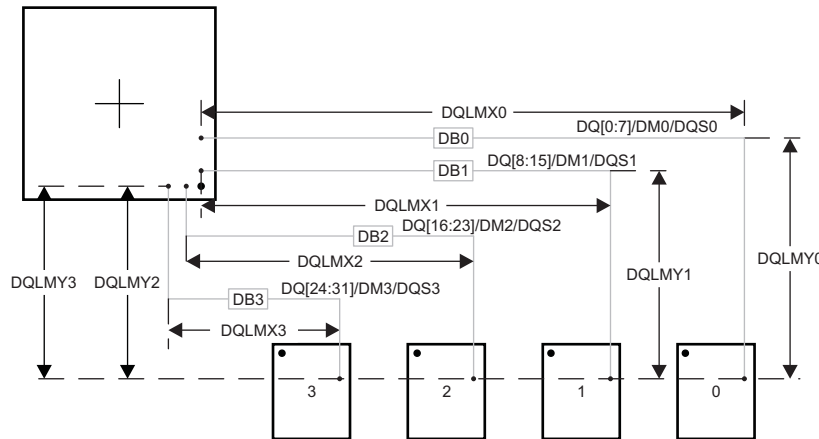

DB0 - DB3 represent data bytes 0 - 3.

There are four DQLMs, one for each byte (32-bit interface). Each DQLM is the longest Manhattan distance of the byte; therefore:

$$\begin{aligned}
 DQLM0 &= DQLMX0 + DQLMY0 \\
 DQLM1 &= DQLMX1 + DQLMY1 \\
 DQLM2 &= DQLMX2 + DQLMY2 \\
 DQLM3 &= DQLMX3 + DQLMY3
 \end{aligned}$$

**Figure 7-28. DQLM for Any Number of Allowed DDR3 Devices**

**Table 7-13. Data Routing Specification<sup>(2)</sup>**

NO.	PARAMETER	MIN	TYP	MAX	UNIT
DRS31	DB0 length			340	ps
DRS32	DB1 length			340	ps
DRS33	DB2 length			340	ps
DRS34	DB3 length			340	ps
DRS35	DBn skew <sup>(3)</sup>			5	ps
DRS36	DQSn+ to DQSn- skew			1	ps
DRS37	DQSn to DBn skew <sup>(3)(4)</sup>			5 <sup>(10)</sup>	ps
DRS38	Vias per trace			2 <sup>(1)</sup>	vias
DRS39	Via count difference			0 <sup>(10)</sup>	vias
DRS310	Center-to-center DBn to other DDR3 trace spacing <sup>(6)</sup>	4			w <sup>(5)</sup>
DRS311	Center-to-center DBn to other DBn trace spacing <sup>(7)</sup>	3			w <sup>(5)</sup>

**Table 7-13. Data Routing Specification<sup>(2)</sup> (continued)**

NO.	PARAMETER	MIN	TYP	MAX	UNIT
DRS312	DQSn center-to-center spacing <sup>(8)</sup> <sup>(9)</sup>				
DRS313	DQSn center-to-center spacing to other net	4			w <sup>(5)</sup>

- (1) Max value is based upon conservative signal integrity approach. This value could be extended only if detailed signal integrity analysis of rise time and fall time confirms desired operation.
- (2) External termination disallowed. Data termination should use built-in ODT functionality.
- (3) Length matching is only done within a byte. Length matching across bytes is neither required nor recommended.
- (4) Each DQS pair is length matched to its associated byte.
- (5) Center-to-center spacing is allowed to fall to minimum 2w for up to 1250 mils of routed length.
- (6) Other DDR3 trace spacing means other DDR3 net classes not within the byte.
- (7) This applies to spacing within the net classes of a byte.
- (8) DQS pair spacing is set to ensure proper differential impedance.
- (9) The most important thing to do is control the impedance so inadvertent impedance mismatches are not created. Generally speaking, center-to-center spacing should be either 2w or slightly larger than 2w to achieve a differential impedance equal to twice the singleended impedance, Zo.
- (10) Via count difference may increase by 1 only if accurate 3-D modeling of the signal flight times – including accurately modeled signal propagation through vias – has been applied to ensure DBn skew and DQSn to DBn skew maximums are not exceeded.

### 7.3 High Speed Differential Signal Routing Guidance

The [High Speed Interface Layout Guidelines Application Report](#) provides guidance for successful routing of the high speed differential signals. This includes PCB stackup and materials guidance as well as routing skew, length and spacing limits. TI supports *only* designs that follow the board design guidelines contained in the application report.

### 7.4 Power Distribution Network Implementation Guidance

The [Sitara Processor Power Distribution Networks: Implementation and Analysis](#) provides guidance for successful implementation of the power distribution network. This includes PCB stackup guidance as well as guidance for optimizing the selection and placement of the decoupling capacitors. TI supports *only* designs that follow the board design guidelines contained in the application report.

### 7.5 Thermal Solution Guidance

The [Thermal Design Guide for DSP and Arm Application Processors Application Report](#) and the [AM572x Thermal Considerations Application Report](#) provide guidance for successful implementation of a thermal solution for system designs that contain an AM57xx application processor. They provide background information on common terms and methods related to thermal solutions. Test data and thermal calculations are also provided for a sample design. TI supports *only* designs that follow the system design guidelines contained in the application reports. Devices must be operated within their rated temperature ranges at all times to maintain proper function and rated Power On Hours.

### 7.6 Single-Ended Interfaces

#### 7.6.1 General Routing Guidelines

The following paragraphs detail the routing guidelines that must be observed when routing the various functional LVCMOS interfaces.

- Line spacing:
  - For a line width equal to  $W$ , the spacing between two lines must be  $2W$ , at least. This minimizes the crosstalk between switching signals between the different lines. On the PCB, this is not achievable everywhere (for example, when breaking signals out from the device package), but it is recommended to follow this rule as much as possible. When violating this guideline, minimize the length of the traces running parallel to each other (see [Figure 7-29](#)).

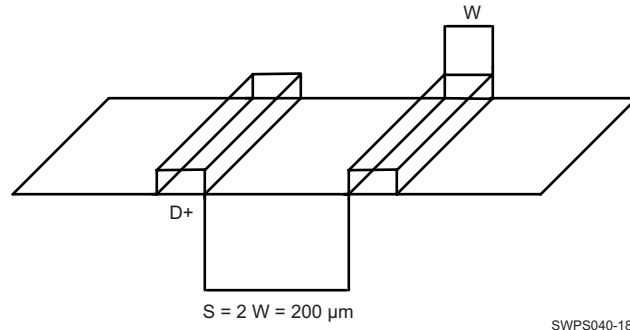

**Figure 7-29. Ground Guard Illustration**

- Length matching (unless otherwise specified):
  - For bus or traces at frequencies less than 10 MHz, the trace length matching (maximum length difference between the longest and the shortest lines) must be less than 25 mm.
  - For bus or traces at frequencies greater than 10 MHz, the trace length matching (maximum length difference between the longest and the shortest lines) must be less than 2.5 mm.
- Characteristic impedance
  - Unless otherwise specified, the characteristic impedance for single-ended interfaces is recommended to be between 35- $\Omega$  and 65- $\Omega$ .
- Multiple peripheral support
  - For interfaces where multiple peripherals have to be supported in the star topology, the length of each branch has to be balanced. Before closing the PCB design, it is highly recommended to verify signal integrity based on simulations including actual PCB extraction.

## 7.6.2 QSPI Board Design and Layout Guidelines

The following section details the routing guidelines that must be observed when routing the QSPI interfaces.

- The `qspi1_sclk` output signal must be looped back into the `qspi1_rtclk` input.
- The signal propagation delay from the `qspi1_sclk` ball to the QSPI device CLK input pin (A to C) must be approximately equal to the signal propagation delay from the QSPI device CLK pin to the `qspi1_rtclk` ball (C to D).
- The signal propagation delay from the QSPI device CLK pin to the `qspi1_rtclk` ball (C to D) must be approximately equal to the signal propagation delay of the control and data signals between the QSPI device and the SoC device (E to F, or F to E).
- The signal propagation delay from the `qspi1_sclk` signal to the series terminators ( $R2 = 10 \Omega$ ) near the QSPI device must be  $< 450 \text{ pS}$  ( $\sim 7 \text{ cm}$  as stripline or  $\sim 8 \text{ cm}$  as microstrip)
- 50  $\Omega$  PCB routing is recommended along with series terminations, as shown in [Figure 7-30](#).
- Propagation delays and matching:
  - A to C = C to D = E to F.
  - Matching skew:  $< 60 \text{ pS}$
  - A to B  $< 450 \text{ pS}$
  - B to C = as small as possible ( $< 60 \text{ pS}$ )

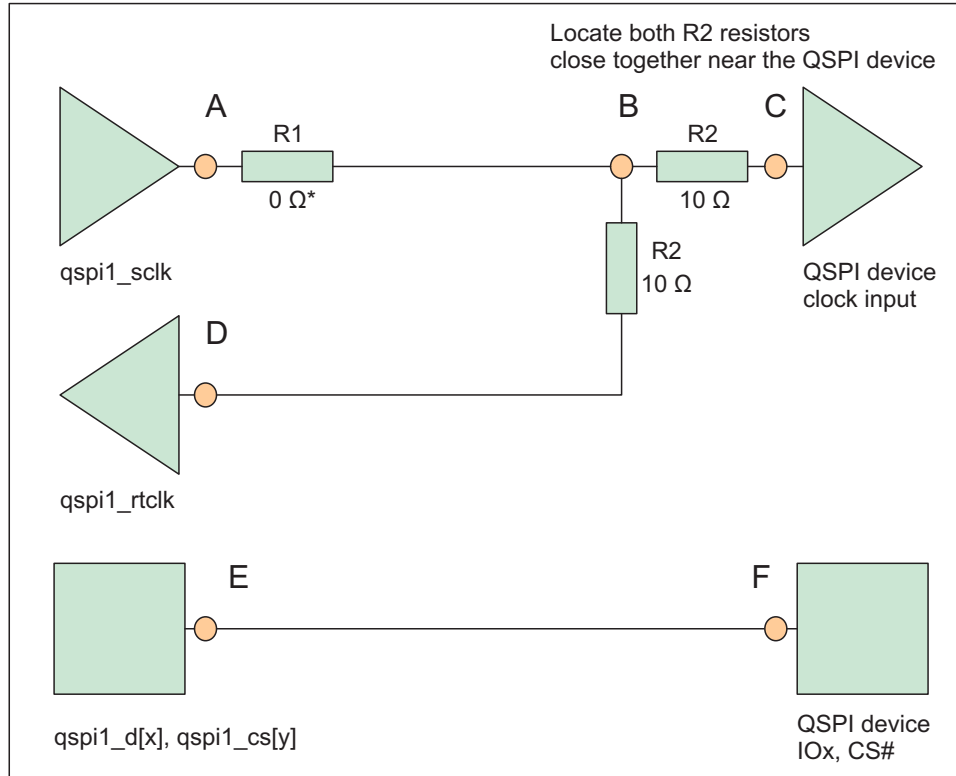

SPRS906\_PCB\_QSPI\_01

- (1) \*0 Ω resistor (R1), located as close as possible to the qspi1\_sclk pin, is placeholder for fine-tuning if needed.

Figure 7-30. QSPI Interface High Level Schematic

### 7.7 LJCB\_REFN/P Connections

A Common Refclk Rx Architecture is required to be used for the device PCIe interface. Specifically, two modes of Common Refclk Rx Architecture are supported:

- **External REFCLK Mode:** An common external 100 MHz clock source is distributed to both the Device and the link partner
- **Output REFCLK Mode:** A 100 MHz HCSL clock source is output by the device and used by the link partner

In **External REFCLK Mode**, a high-quality, low-jitter, differential HCSL 100 MHz clock source compliant to the PCIe REFCLK AC Specifications should be provided on the Device's ljcb\_clkn / ljcb\_clkp inputs.

Alternatively, an LVDS clock source can be used with the following additional requirements:

- External AC coupling capacitors described in Table 7-14 should be populated at the ljcb\_clkn / ljcb\_clkp inputs.
- All termination requirements (ex. parallel 100 Ω termination) from the clock source manufacturer should be followed.

In **Output REFCLK Mode**, the 100 MHz clock from the Device's DPLL\_PCIE\_REF should be output on the Device's ljcb\_clkn / ljcb\_clkp pins and used as the HCSL REFCLK by the link partner. External near-side termination to ground described in Table 7-15 is required on both of the ljcb\_clkn / ljcb\_clkp outputs in this mode.

Table 7-14. LJCB\_REFN/P Requirements in External LVDS REFCLK Mode

PARAMETER	MIN	TYP	MAX	UNIT
ljcb_clkn / ljcb_clkp AC coupling capacitor value		100		nF

**Table 7-14. LJCB\_REFN/P Requirements in External LVDS REFCLK Mode (continued)**

PARAMETER	MIN	TYP	MAX	UNIT
ljcb_clkn / ljcb_clkp AC coupling capacitor package size		0402	0603	EIA <sup>(1)(2)</sup>

(1) EIA LxW units, that is, a 0402 is a 40x20 mils surface mount capacitor.

(2) The physical size of the capacitor should be as small as practical. Use the same size on both lines in each pair placed side by side.

**Table 7-15. LJCB\_REFN/P Requirements in Output REFCLK Mode**

PARAMETER	MIN	TYP	MAX	UNIT
ljcb_clkn / ljcb_clkp near-side termination to ground value	47.5	50	52.5	$\Omega$

## 7.8 Clock Routing Guidelines

### 7.8.1 32-kHz Oscillator Routing

When designing the printed-circuit board:

- Keep the crystal as close as possible to the crystal pins X1 and X2.
- Keep the trace lengths short and small to reduce capacitor loading and prevent unwanted noise pickup.
- Place a guard ring around the crystal and tie the ring to ground to help isolate the crystal from unwanted noise pickup.
- Keep all signals out from beneath the crystal and the X1 and X2 pins to prevent noise coupling.
- Finally, an additional local ground plane on an adjacent PCB layer can be added under the crystal to shield it from unwanted pickup from traces on other layers of the board. This plane must be isolated from the regular PCB ground plane and tied to the GND pin of the RTC. The plane must not be any larger than the perimeter of the guard ring. Make sure that this ground plane does not contribute to significant capacitance (a few pF) between the signal line and ground on the connections that run from X1 and X2 to the crystal.

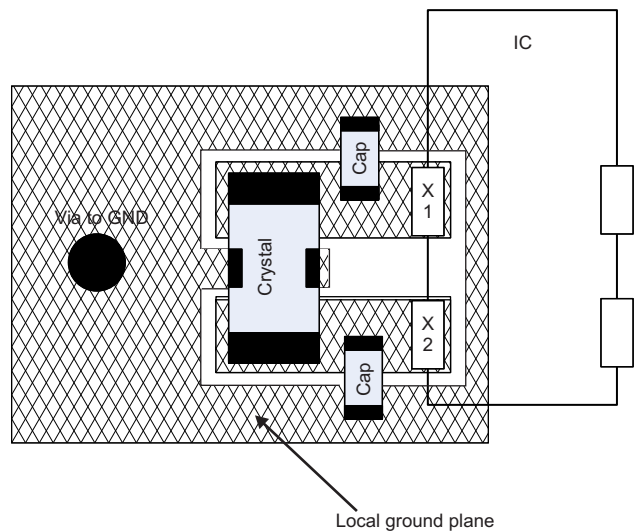

**Figure 7-31. Slow Clock PCB Requirements**

### 7.8.2 Oscillator Ground Connection

Although the impedance of a ground plane is low it is, of course, not zero. Therefore, any noise current in the ground plane causes a voltage drop in the ground. Figure 7-32 shows the grounding scheme for slow (low frequency) clock generated from the internal oscillator.

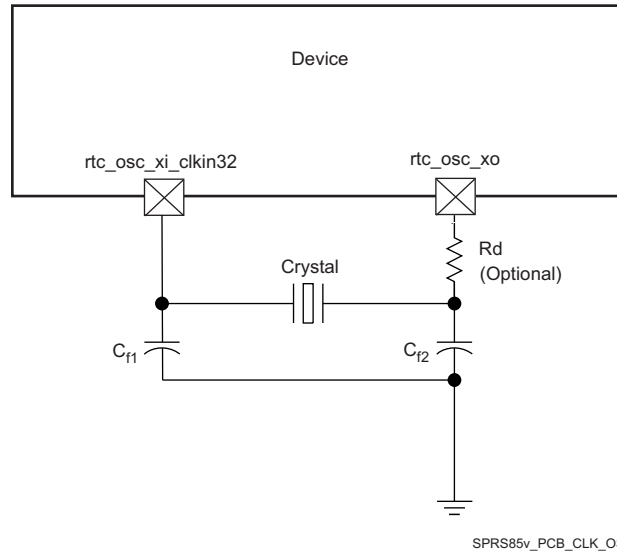

**Figure 7-32. Grounding Scheme for Low-Frequency Clock**

Figure 7-33 shows the grounding scheme for high-frequency clock.

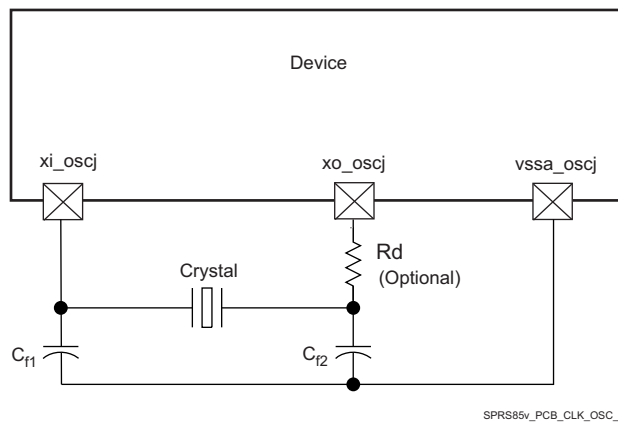

(1) j in \*\_osc = 0 or 1

**Figure 7-33. Grounding Scheme for High-Frequency Clock**

## 8 Device and Documentation Support

TI offers an extensive line of development tools, including methods to evaluate the performance of the processors, generate code, develop algorithm implementations, and fully integrate and debug software and hardware modules as listed below.

### 8.1 Device Nomenclature

To designate the stages in the product development cycle, TI assigns prefixes to the part numbers of all microprocessors (MPUs) and support tools. Each device has one of three prefixes: X, P, or null (no prefix) (for example, AM574x). Texas Instruments recommends two of three possible prefix designators for its support tools: TMDX and TMDS. These prefixes represent evolutionary stages of product development from engineering prototypes (TMDX) through fully qualified production devices and tools (TMDS).

Device development evolutionary flow:

- X** Experimental device that is not necessarily representative of the final device's electrical specifications and may not use production assembly flow.
- P** Prototype device that is not necessarily the final silicon die and may not necessarily meet final electrical specifications.
- null** Production version of the silicon die that is fully qualified.

Support tool development evolutionary flow:

- TMDX** Development-support product that has not yet completed Texas Instruments internal qualification testing.
- TMDS** Fully-qualified development-support product.

X and P devices and TMDX development-support tools are shipped against the following disclaimer:

"Developmental product is intended for internal evaluation purposes."

Production devices and TMDS development-support tools have been characterized fully, and the quality and reliability of the device have been demonstrated fully. TI's standard warranty applies.

Predictions show that prototype devices (X or P) have a greater failure rate than the standard production devices. Texas Instruments recommends that these devices not be used in any production system because their expected end-use failure rate still is undefined. Only qualified production devices are to be used.

For orderable part numbers of AM574x devices in the ABZ package type, see the Package Option Addendum of this document, the TI website ([ti.com](http://ti.com)), or contact your TI sales representative.

#### 8.1.1 Standard Package Symbolization

---

#### NOTE

Some devices may have a cosmetic circular marking visible on the top of the device package which results from the production test process. In addition, some devices may also show a color variation in the package substrate which results from the substrate manufacturer. These differences are cosmetic only with no reliability impact.

---



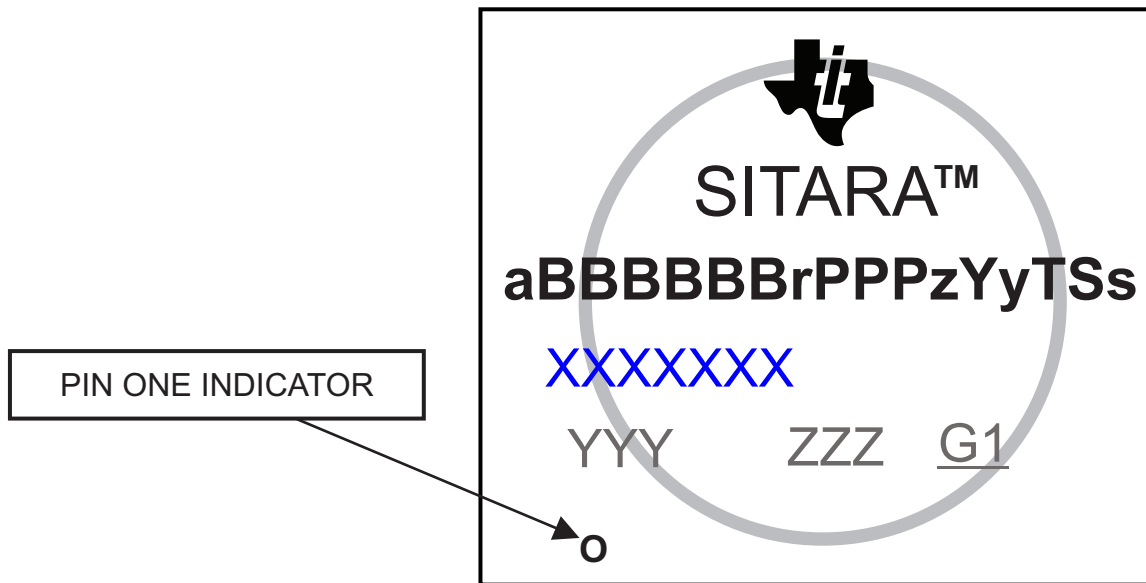

SPRS906\_PACK\_01

Figure 8-1. Printed Device Reference

8.1.2 Device Naming Convention

Table 8-1. Nomenclature Description

FIELD PARAMETER	FIELD DESCRIPTION	VALUE	DESCRIPTION
a	Device evolution stage	X	Prototype
		P	Preproduction (production test flow, no reliability data)
		BLANK	Production
BBBBBB	Base production part number	AM5749	See Table 3-1, Device Comparison
		AM5748	
		AM5746	
r	Device revision	BLANK	SR 1.0
PPP	Package Designator	ABZ	ABZ S-PBGA-N760 (23 mm x 23 mm) Package
z	Device Speed	X	High speed grade (See Table 5-2, Speed Grade Maximum Frequency)
		OTHER	Alternate speed grade
Yy	Device type	E	All industrial protocols enabled (basic protocols plus EtherCAT slave and POWERLINK slave)
		BLANK	Basic Industrial protocols enabled
T	Temperature <sup>(2)</sup>	A	Extended (See Section 5.4, Recommended Operating Conditions)
		BLANK	Commercial (See Section 5.4, Recommended Operating Conditions)
Ss	Security Identifier	S	High-Security device, Secure Boot Supported
		Ss	Dummy key High-Security device, Secure Boot Supported
		BLANK	General purpose device
XXXXXXX	Lot Trace Code (LTC)		
YYY	Production Code; For TI use only		
ZZZ	Production Code; For TI use only		
O	Pin one designator		
G1	ECAT—Green package designator		

- (1) To designate the stages in the product development cycle, TI assigns prefixes to the part numbers. These prefixes represent evolutionary stages of product development from engineering prototypes through fully qualified production devices. Prototype devices are shipped against the following disclaimer:  
 "This product is still in development and is intended for internal evaluation purposes."  
 Notwithstanding any provision to the contrary, TI makes no warranty expressed, implied, or statutory, including any implied warranty of merchantability of fitness for a specific purpose, of this device.
- (2) Applies to device max junction temperature.

---

**NOTE**

BLANK in the symbol or part number is collapsed so there are no gaps between characters.

---

## 8.2 Tools and Software

The following products support development for AM574x platforms:

### Design Kits and Evaluation Modules

**AM574x Industrial Development Kit (IDK)** Key Document AM574x Industrial Development Kit (IDK) Evaluation Module (EVM) (PDF 1688 KB) 07 Mar 2018 View All Technical Documents (9) Description The AM574x Industrial Development Kit (IDK) is a development platform for evaluating the industrial communication and control capabilities of Sitara AM574x/2x processors for applications in factory automation, drives, robotics, grid infrastructure, and more. AM574x/2x processors include dual PRU-ICSS (Programmable Real-time Unit for Industrial Communications) sub-systems which can be used for industrial Ethernet protocols such as Profinet, EtherCAT, Ethernet/IP, and others. The TMDXIDK574 breaks out six ports of Ethernet, four of which can be used concurrently: 2x Gb Ethernet ports and 2x 10/100 Ethernet ports from the PRU-ICSS subsystems.

### Development tools

**Clock Tree Tool for Sitara, Automotive, Vision Analytics, and Digital Signal Processors** The Clock Tree Tool (CTT) for Sitara™ Arm®, Automotive, and Digital Signal Processors is an interactive clock tree configuration software that provides information about the clocks and modules in these TI devices. It allows the user to:

- Visualize the device clock tree
- Interact with clock tree elements and view the effect on PRCM registers
- Interact with the PRCM registers and view the effect on the device clock tree
- View a trace of all the device registers affected by the user interaction with clock tree

**Code Composer Studio™ Integrated Development Environment** Code Composer Studio (CCS) Integrated Development Environment (IDE) is a development environment that supports TI's Microcontroller and Embedded Processors portfolio. Code Composer Studio comprises a suite of tools used to develop and debug embedded applications. It includes an optimizing C/C++ compiler, source code editor, project build environment, debugger, profiler, and many other features. The intuitive IDE provides a single user interface taking you through each step of the application development flow. Familiar tools and interfaces allow users to get started faster than ever before. Code Composer Studio combines the advantages of the Eclipse software framework with advanced embedded debug capabilities from TI resulting in a compelling feature-rich development environment for embedded developers.

**Pin mux tool** The Pin MUX Utility is a software tool which provides a Graphical User Interface for configuring pin multiplexing settings, resolving conflicts and specifying I/O cell characteristics for TI MPUs. Results are output as C header/code files that can be imported into software development kits (SDKs) or used to configure customer's custom software. Version 4 of the Pin Mux utility adds the capability of automatically selecting a mux configuration that satisfies the entered requirements.

**Power Estimation Tool (PET)** Power Estimation Tool (PET) provides users the ability to gain insight in to the power consumption of select TI processors. The tool includes the ability for the user to choose multiple application scenarios and understand the power consumption as well as how advanced power saving techniques can be applied to further reduce overall power consumption.

## Models

[AM574x BSDL Model](#) BSDL Model

[AM574x IBIS Model](#) IBIS Model

[AM574x Thermal Model](#) Thermal Model

[AM57x SerDes IBIS-AMI Models](#) IBIS-AMI Model

For a complete listing of development-support tools for the processor platform, visit the Texas Instruments website at [ti.com](http://ti.com). For information on pricing and availability, contact the nearest TI field sales office or authorized distributor.

## 8.3 Documentation Support

To receive notification of documentation updates, navigate to the device product folder on [ti.com](http://ti.com). Click on *Alert me* to register and receive a weekly digest of any product information that has changed. For change details, review the revision history included in any revised document.

The following documents describe the AM574x devices.

### Technical Reference Manual

[AM574x, AM576x Sitara™ Processors Silicon Revision 1.0 Technical Reference Manual](#) Details the integration, the environment, the functional description, and the programming models for each peripheral and subsystem in the AM574x and AM576x family of devices.

### Errata

[AM574x, AM576x Sitara™ Processors Silicon Revision 1.0 Silicon Errata](#) Describes the known exceptions to the functional specifications for the device.

## 8.4 Related Links

[Table 8-2](#) lists quick access links. Categories include technical documents, support and community resources, tools and software, and quick access to order now.

**Table 8-2. Related Links**

PARTS	PRODUCT FOLDER	ORDER NOW	TECHNICAL DOCUMENTS	TOOLS & SOFTWARE	SUPPORT & COMMUNITY
AM5749	<a href="#">Click here</a>	<a href="#">Click here</a>	<a href="#">Click here</a>	<a href="#">Click here</a>	<a href="#">Click here</a>
AM5748	<a href="#">Click here</a>	<a href="#">Click here</a>	<a href="#">Click here</a>	<a href="#">Click here</a>	<a href="#">Click here</a>
AM5746	<a href="#">Click here</a>	<a href="#">Click here</a>	<a href="#">Click here</a>	<a href="#">Click here</a>	<a href="#">Click here</a>

## 8.5 Support Resources

[TI E2E™ support forums](#) are an engineer's go-to source for fast, verified answers and design help — straight from the experts. Search existing answers or ask your own question to get the quick design help you need.

Linked content is provided "AS IS" by the respective contributors. They do not constitute TI specifications and do not necessarily reflect TI's views; see TI's [Terms of Use](#).

## 8.6 Trademarks

Sitara, Code Composer Studio, E2E are trademarks of Texas Instruments.

Neon, CoreSight are trademarks of Arm Limited (or its subsidiaries) in the US and/or elsewhere.

Arm, Cortex, TrustZone, Thumb are registered trademarks of Arm Limited (or its subsidiaries) in the US and/or elsewhere.

EtherCAT is a registered trademark of Beckhoff Automation GmbH.

EnDAT is a registered trademark of Dr. Johannes Heidenhain GmbH.

HDMI is a trademark of HDMI Licensing, LLC.

USSE is a trademark of Imagination Technologies Limited.  
PowerVR is a registered trademark of Imagination Technologies Limited.  
JTAG is a registered trademark of JTAG Technologies, Inc.  
1-Wire is a registered trademark of Maxim Integrated Products, Inc.  
MMC, eMMC are trademarks of MultiMediaCard Association.  
I<sup>2</sup>C is a trademark of NXP Semiconductors.  
PCI-Express, PCIe are registered trademarks of PCI-SIG.  
Secure Digital, SD are registered trademarks of SD Card Association.  
Vivante is a registered trademark of Vivante Corporation.  
All other trademarks are the property of their respective owners.

## 8.7 Electrostatic Discharge Caution



This integrated circuit can be damaged by ESD. Texas Instruments recommends that all integrated circuits be handled with appropriate precautions. Failure to observe proper handling and installation procedures can cause damage.

ESD damage can range from subtle performance degradation to complete device failure. Precision integrated circuits may be more susceptible to damage because very small parametric changes could cause the device not to meet its published specifications.

## 8.8 Glossary

[TI Glossary](#) This glossary lists and explains terms, acronyms, and definitions.

## 9 Mechanical, Packaging, and Orderable Information

### 9.1 Packaging Information

The following pages include mechanical, packaging, and orderable information. This information is the most current data available for the designated devices. This data is subject to change without notice and revision of this document. For browser-based versions of this data sheet, refer to the left-hand navigation.

**PACKAGING INFORMATION**

Orderable Device	Status (1)	Package Type	Package Drawing	Pins	Package Qty	Eco Plan (2)	Lead/Ball Finish (6)	MSL Peak Temp (3)	Op Temp (°C)	Device Marking (4/5)	Samples
AM5746ABZX	ACTIVE	FCBGA	ABZ	760	60	Green (RoHS & no Sb/Br)	SNAGCU	Level-3-250C-168 HR	0 to 90	AM5746ABZX 941 941 ABZ	<a href="#">Samples</a>
AM5746ABZXA	ACTIVE	FCBGA	ABZ	760	60	Green (RoHS & no Sb/Br)	SNAGCU	Level-3-250C-168 HR	-40 to 105	AM5746ABZXA 941 941 ABZ	<a href="#">Samples</a>
AM5746ABZXEA	ACTIVE	FCBGA	ABZ	760	1	Green (RoHS & no Sb/Br)	SNAGCU	Level-3-250C-168 HR	-40 to 105	AM5746ABZXEA 941 941 ABZ	<a href="#">Samples</a>
AM5748ABZX	ACTIVE	FCBGA	ABZ	760	60	Green (RoHS & no Sb/Br)	SNAGCU	Level-3-250C-168 HR	0 to 90	AM5748ABZX 941 941 ABZ	<a href="#">Samples</a>
AM5748ABZXA	ACTIVE	FCBGA	ABZ	760	1	Green (RoHS & no Sb/Br)	SNAGCU	Level-3-250C-168 HR	-40 to 105	AM5748ABZXA 941 941 ABZ	<a href="#">Samples</a>
AM5748ABZXEA	ACTIVE	FCBGA	ABZ	760	60	Green (RoHS & no Sb/Br)	SNAGCU	Level-3-250C-168 HR	-40 to 105	AM5748ABZXEA 941 941 ABZ	<a href="#">Samples</a>
AM5749ABZX	ACTIVE	FCBGA	ABZ	760	60	Green (RoHS & no Sb/Br)	SNAGCU	Level-3-250C-168 HR	0 to 90	AM5749ABZX 941 941 ABZ	<a href="#">Samples</a>
AM5749ABZXA	ACTIVE	FCBGA	ABZ	760	60	Green (RoHS & no Sb/Br)	SNAGCU	Level-3-250C-168 HR	-40 to 105	AM5749ABZXA 941 941 ABZ	<a href="#">Samples</a>
AM5749ABZXEA	ACTIVE	FCBGA	ABZ	760	1	Green (RoHS & no Sb/Br)	SNAGCU	Level-3-250C-168 HR	-40 to 105	AM5749ABZXEA 941 941 ABZ	<a href="#">Samples</a>
XAM5748ABZXEA	ACTIVE	FCBGA	ABZ	760	1	TBD	Call TI	Call TI	-40 to 105		<a href="#">Samples</a>

(1) The marketing status values are defined as follows:

**ACTIVE:** Product device recommended for new designs.

**LIFEBUY:** TI has announced that the device will be discontinued, and a lifetime-buy period is in effect.

**NRND:** Not recommended for new designs. Device is in production to support existing customers, but TI does not recommend using this part in a new design.

**PREVIEW:** Device has been announced but is not in production. Samples may or may not be available.

**OBSOLETE:** TI has discontinued the production of the device.

---

(2) **RoHS:** TI defines "RoHS" to mean semiconductor products that are compliant with the current EU RoHS requirements for all 10 RoHS substances, including the requirement that RoHS substance do not exceed 0.1% by weight in homogeneous materials. Where designed to be soldered at high temperatures, "RoHS" products are suitable for use in specified lead-free processes. TI may reference these types of products as "Pb-Free".

**RoHS Exempt:** TI defines "RoHS Exempt" to mean products that contain lead but are compliant with EU RoHS pursuant to a specific EU RoHS exemption.

**Green:** TI defines "Green" to mean the content of Chlorine (Cl) and Bromine (Br) based flame retardants meet JS709B low halogen requirements of  $\leq 1000$ ppm threshold. Antimony trioxide based flame retardants must also meet the  $\leq 1000$ ppm threshold requirement.

(3) MSL, Peak Temp. - The Moisture Sensitivity Level rating according to the JEDEC industry standard classifications, and peak solder temperature.

(4) There may be additional marking, which relates to the logo, the lot trace code information, or the environmental category on the device.

(5) Multiple Device Markings will be inside parentheses. Only one Device Marking contained in parentheses and separated by a "~" will appear on a device. If a line is indented then it is a continuation of the previous line and the two combined represent the entire Device Marking for that device.

(6) Lead/Ball Finish - Orderable Devices may have multiple material finish options. Finish options are separated by a vertical ruled line. Lead/Ball Finish values may wrap to two lines if the finish value exceeds the maximum column width.

**Important Information and Disclaimer:** The information provided on this page represents TI's knowledge and belief as of the date that it is provided. TI bases its knowledge and belief on information provided by third parties, and makes no representation or warranty as to the accuracy of such information. Efforts are underway to better integrate information from third parties. TI has taken and continues to take reasonable steps to provide representative and accurate information but may not have conducted destructive testing or chemical analysis on incoming materials and chemicals. TI and TI suppliers consider certain information to be proprietary, and thus CAS numbers and other limited information may not be available for release.

In no event shall TI's liability arising out of such information exceed the total purchase price of the TI part(s) at issue in this document sold by TI to Customer on an annual basis.

# ABZ0760A

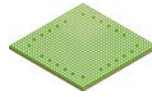

# PACKAGE OUTLINE

## FCBGA - 1.63 mm max height

BALL GRID ARRAY

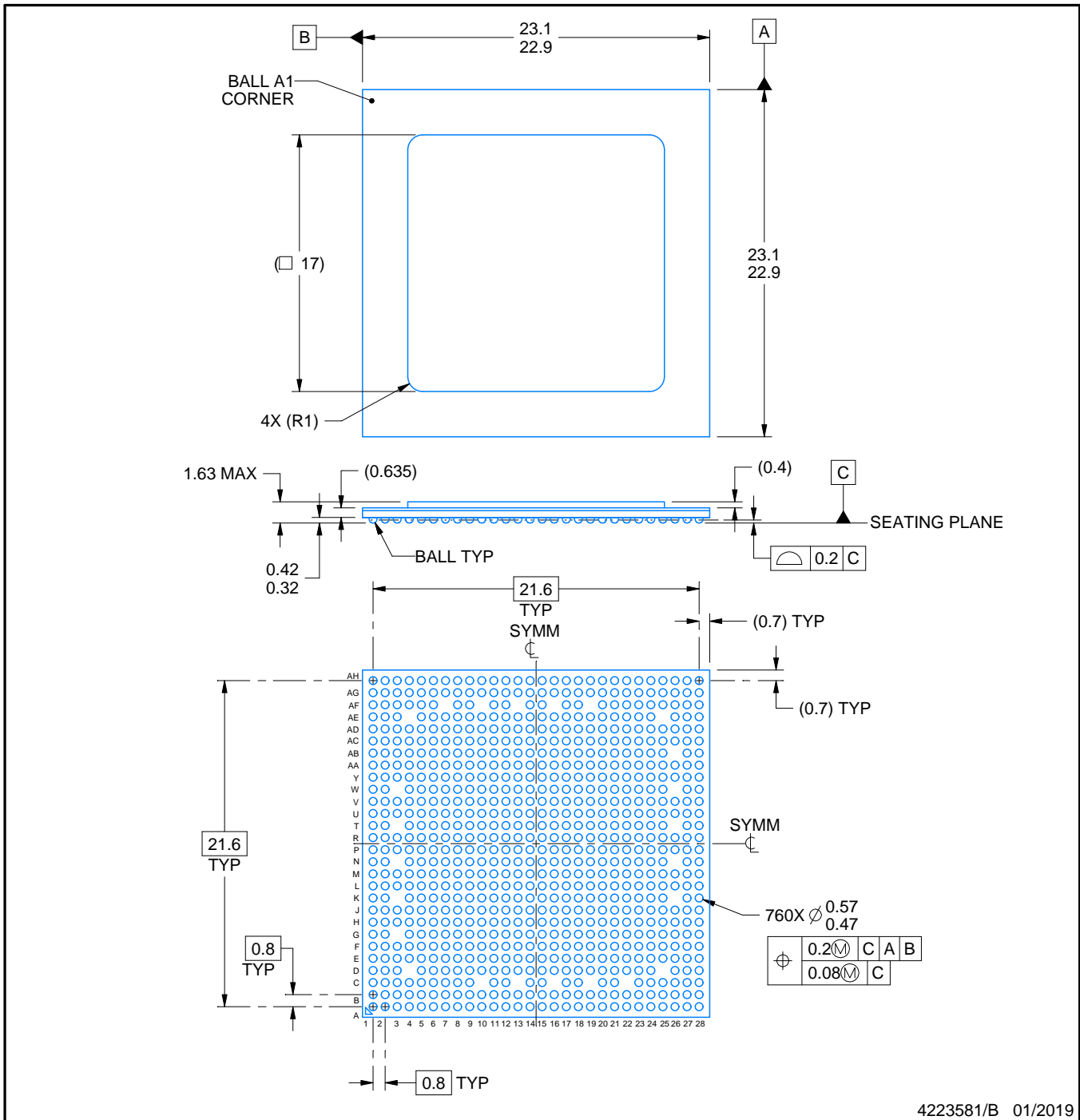

4223581/B 01/2019

### NOTES:

1. All linear dimensions are in millimeters. Any dimensions in parenthesis are for reference only. Dimensioning and tolerancing per ASME Y14.5M.
2. This drawing is subject to change without notice.



# EXAMPLE BOARD LAYOUT

**ABZ0760A**

**FCBGA - 1.63 mm max height**

BALL GRID ARRAY

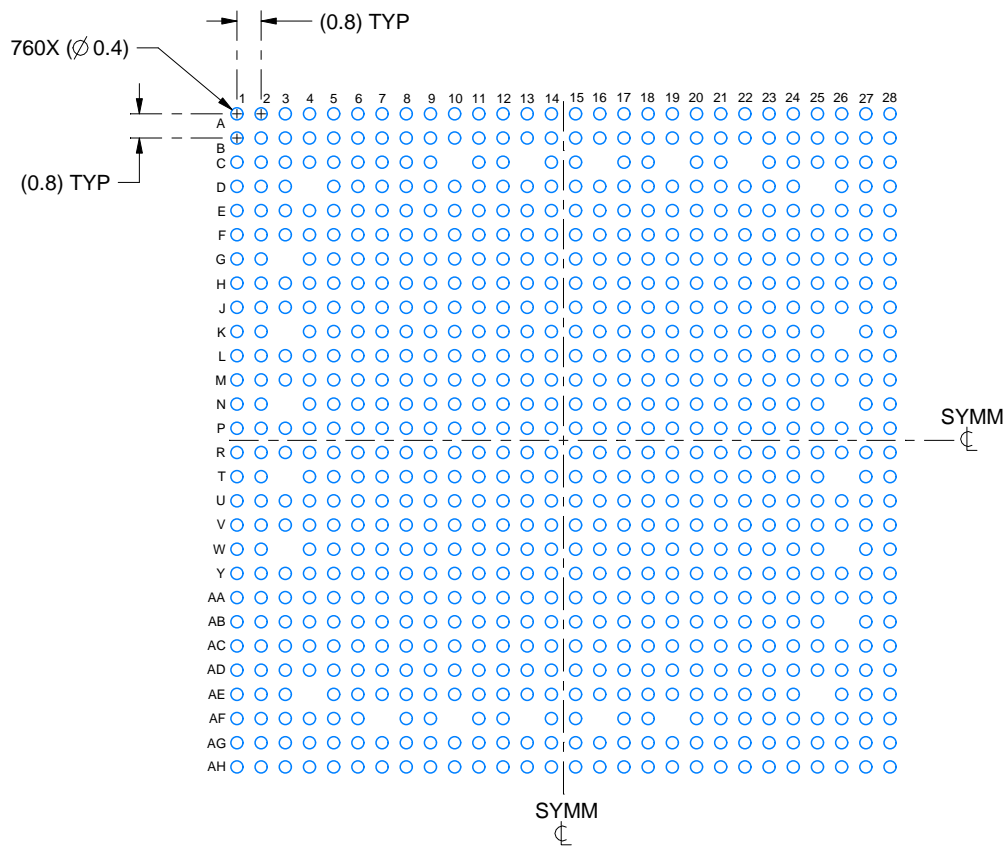

LAND PATTERN EXAMPLE  
EXPOSED METAL SHOWN  
SCALE: 4X

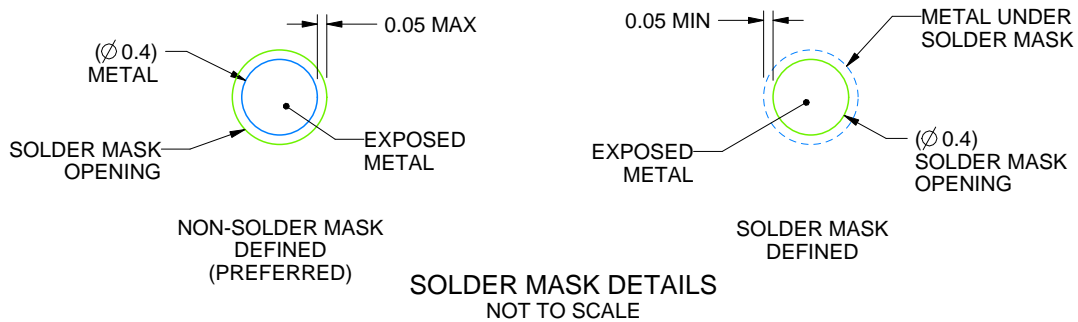

4223581/B 01/2019

NOTES: (continued)

- Final dimensions may vary due to manufacturing tolerance considerations and also routing constraints. See Texas Instruments Literature No. SPRU811 ([www.ti.com/lit/spru811](http://www.ti.com/lit/spru811)).

# EXAMPLE STENCIL DESIGN

## ABZ0760A

## FCBGA - 1.63 mm max height

BALL GRID ARRAY

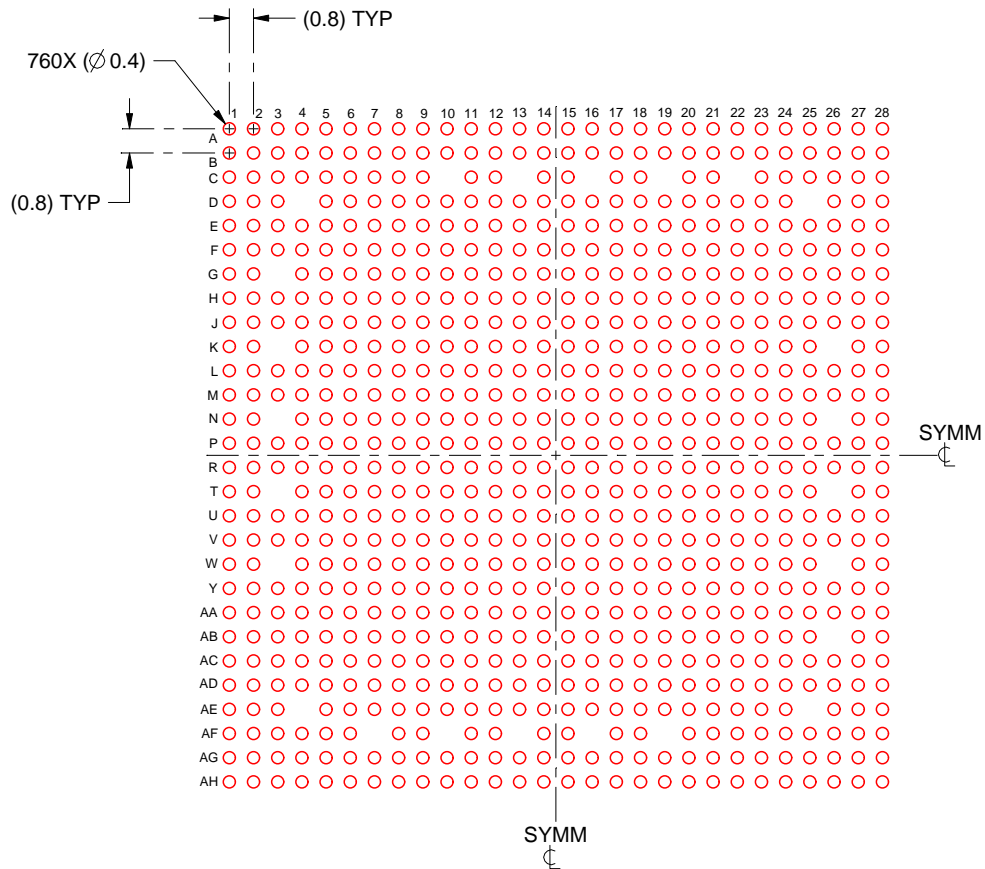

SOLDER PASTE EXAMPLE  
BASED ON 0.15 mm THICK STENCIL  
SCALE: 4X

4223581/B 01/2019

NOTES: (continued)

4. Laser cutting apertures with trapezoidal walls and rounded corners may offer better paste release.

## IMPORTANT NOTICE AND DISCLAIMER

TI PROVIDES TECHNICAL AND RELIABILITY DATA (INCLUDING DATASHEETS), DESIGN RESOURCES (INCLUDING REFERENCE DESIGNS), APPLICATION OR OTHER DESIGN ADVICE, WEB TOOLS, SAFETY INFORMATION, AND OTHER RESOURCES "AS IS" AND WITH ALL FAULTS, AND DISCLAIMS ALL WARRANTIES, EXPRESS AND IMPLIED, INCLUDING WITHOUT LIMITATION ANY IMPLIED WARRANTIES OF MERCHANTABILITY, FITNESS FOR A PARTICULAR PURPOSE OR NON-INFRINGEMENT OF THIRD PARTY INTELLECTUAL PROPERTY RIGHTS.

These resources are intended for skilled developers designing with TI products. You are solely responsible for (1) selecting the appropriate TI products for your application, (2) designing, validating and testing your application, and (3) ensuring your application meets applicable standards, and any other safety, security, or other requirements. These resources are subject to change without notice. TI grants you permission to use these resources only for development of an application that uses the TI products described in the resource. Other reproduction and display of these resources is prohibited. No license is granted to any other TI intellectual property right or to any third party intellectual property right. TI disclaims responsibility for, and you will fully indemnify TI and its representatives against, any claims, damages, costs, losses, and liabilities arising out of your use of these resources.

TI's products are provided subject to TI's Terms of Sale ([www.ti.com/legal/termsofsale.html](http://www.ti.com/legal/termsofsale.html)) or other applicable terms available either on [ti.com](http://ti.com) or provided in conjunction with such TI products. TI's provision of these resources does not expand or otherwise alter TI's applicable warranties or warranty disclaimers for TI products.

Mailing Address: Texas Instruments, Post Office Box 655303, Dallas, Texas 75265  
Copyright © 2020, Texas Instruments Incorporated