

AMC Doc. #: AMC2951_A
November 2001



AMC2950/2951

100mA LOW DROPOUT VOLTAGE REGULATOR

DESCRIPTION	FEATURES
<p>The AMC2950/2951 series is a low power voltage regulator. This device is an excellent choice for use in battery powered applications such as notebook computers, radio control system and cordless telephone.</p> <p>The AMC2950/2951 features very low quiescent current (75μA typ.) and very low dropout voltage (typ. 40mV at light loads and 380mV at 100mA). This makes the AMC2950/2951 ideal as a precision voltage reference.</p> <p>The AMC2951 can be pin-strapped for a fixed output voltage of 3.3V or 5.0V, depending on the version, or programmed from 1.24V to 29V with an external pair of resistors. The Error Flag feature is used as power-on reset for warning of a low output voltage. Other feature is the logic-compatible shutdown input turns on and off the regulator output voltage.</p>	<ul style="list-style-type: none"> ■ Very low quiescent current ■ 5V and 3.3V output voltages available ■ Output programmable from 1.24V to 29V by external pair of resistors ■ High accuracy output voltage ■ Output current of 100mA □ Needs minimum capacitance for stability □ Low dropout voltage □ Extremely tight load and line regulation □ Error Flag warns of output dropout □ Logic-controlled shutdown □ Pin assignment identical to earlier LP2950/2951 series.

APPLICATIONS	PACKAGE PIN OUT
<ul style="list-style-type: none"> ■ Voltage Reference ■ Portable/ Notebook Computers ■ Battery Powered Systems ■ Radio Control System ■ Cordless Telephones ■ Portable Consumer Equipment 	<p>AMC2950 3-Pin Plastic TO-92 (Top View)</p> <p>AMC2951 8-Pin Plastic S.O.I.C. (Top View)</p>

AMC2950-3.3	3.3V fixed
AMC2950-5.0	5.0V fixed
AMC2951-3.3	3.3V fixed
AMC2951	5.0V fixed / Adj

All AMC2950 devices have the output voltage coded as X.X on the package. For AMC2951, 3.3V version is designated on the package, but the 5V version is denoted with no code.

PACKAGE ORDER INFORMATION			
T _A (°C)	LP	Plastic TO-92	DM Plastic SOIC
		3-pin	
0 to 70	AMC2950-X.XLP		AMC2951-3.3DM AMC2951DM
Note: All surface-mount packages are available in Tape & Reel. Append the letter "T" to part number (i.e. AMC2950-X.XLPT or AMC2951-X.XDMT).			

AMC Doc. #: AMC2951_A

November 2001

AMC2950/2951

100mA LOW DROPOUT VOLTAGE REGULATORS

BLOCK DIAGRAM

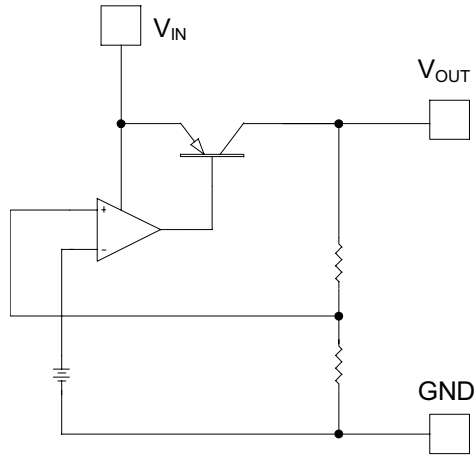

AMC2950

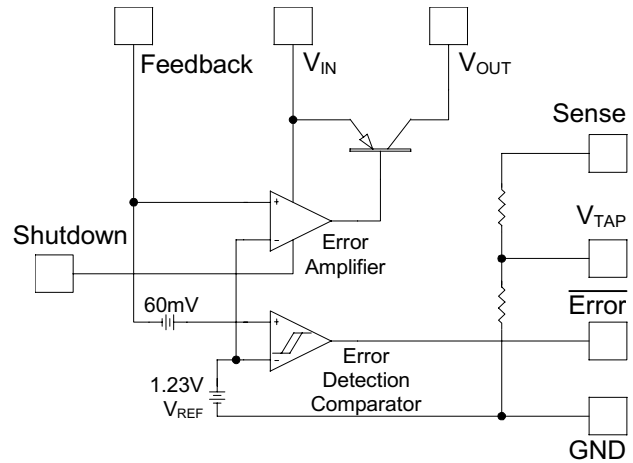

AMC2951

ABSOLUTE MAXIMUM RATINGS (Note 1)

Input Supply Voltage	-0.3V to 30V
Feedback Input Voltage	-0.3V to 30V
Error Flag Output	-0.3V to 30V
Operating Junction Temperature Range, T_J	0°C to 150°C
Storage Temperature Range	-65°C to 150°C
Lead Temperature (soldering, 10 seconds)	260°C
Note 1: Exceeding these ratings could cause damage to the device. All voltages are with respect to Ground. Currents are positive into, negative out of the specified terminal.	

AMC Doc. #: AMC2951_A

November 2001

AMC2950/2951

100mA LOW DROPOUT VOLTAGE REGULATORS

ELECTRICAL CHARACTERISTICS							
Unless otherwise specified, these specifications apply the operating ambient temperatures with $T_A = 25^\circ\text{C}$. $V_{IN} = V_{OUT} + 1\text{V}$, $I_L = 100\mu\text{A}$, and $C_L = 1\mu\text{F}$ for 5V version and $2.2\mu\text{F}$ for 3.3V version. Additional conditions for the 8-pin version are FEEDBACK connected to V TAP, OUTPUT connected to SENSE, and SHUTDOWN $\leq 0.8\text{V}$.							
Parameter	Symbol	Test Conditions	AMC2950/2951			Units	
			Min	Typ	Max		
Output Voltage	AMC2950-3.3	V_{OUT}	$0^\circ\text{C} \leq T_J \leq 85^\circ\text{C}$	3.251	3.300	3.350	mV
	AMC2951-3.3						
	AMC2950-5.0			4.925	5.000	5.075	
	AMC2951						
Output Voltage	AMC2950-3.3	V_{OUT}	$100\mu\text{A} \leq I_L \leq 100\text{mA}$ $0^\circ\text{C} \leq T_J \leq 85^\circ\text{C}$	3.221	3.300	3.379	mV
	AMC2951-3.3						
	AMC2950-5.0			4.880	5.000	5.120	
	AMC2951						
Output Voltage Temperature Coefficient		Note 2		50	150	ppm/ $^\circ\text{C}$	
Line Regulation (Note 3)	ΔV_{OI}	$V_{OUT} + 1\text{V} \leq V_{IN} \leq 30\text{V}$		0.04	0.4	%	
Load Regulation (Note 3)	ΔV_{OL}	$100\mu\text{A} \leq I_L \leq 100\text{mA}$		0.1	0.3	%	
Dropout Voltage (Note 4)	ΔV	$I_L = 100\mu\text{A}$		50	80	mV	
		$I_L = 100\text{mA}$		380	450		
Ground Current	I_Q	$I_L = 100\mu\text{A}$		75	120	μA	
		$I_L = 100\text{mA}$		8	12	mA	
Dropout Ground Current		$V_{IN} = V_{OUT} + 1\text{V}$, $I_L = 100\mu\text{A}$,		110	170	μA	
Current Limit	I_{CL}	$V_{OUT} = 0\text{V}$		160	200	mA	
Thermal Regulation (Note 5)		Note 6		0.05	0.2	%/W	
Output Noise (Note 5)		$C_L = 1\mu\text{F}$		430		μV_{rms}	
		$C_L = 200\mu\text{F}$		160			
		$C_L = 3.3\mu\text{F}$ (Bypass = $0.01\mu\text{F}$, pins 7 to 1)		100			

AMC2950/2951

100mA LOW DROPOUT VOLTAGE REGULATORS

ELECTRICAL CHARACTERISTICS (continued)						
Unless otherwise specified, these specifications apply the operating ambient temperatures with $T_A = 25^\circ\text{C}$. $V_{IN} = V_{OUT} + 1\text{V}$, $I_L = 100\mu\text{A}$, and $C_L = 1\mu\text{F}$ for 5V version and $2.2\mu\text{F}$ for 3.3V version. Additional conditions for the 8-pin version are FEEDBACK connected to V TAP, OUTPUT connected to SENSE, and SHUTDOWN $\leq 0.8\text{V}$.						
Parameter	Symbol	Test Conditions	AMC2950/2951			Units
			Min	Typ	Max	
8-pin Versions Only						
Reference Voltage	V_{REF}	$V_{REF} \leq V_{OUT} \leq V_{IN} - 1\text{V}$, $2.3\text{V} \leq V_{IN} \leq 30\text{V}$, $100\mu\text{A} \leq I_L \leq 100\text{mA}$, $T_J \leq 85^\circ\text{C}$	1.210	1.235	1.260	V
			1.185		1.285	
Feedback Pin Bias Current				20	40	nA
Reference Voltage Temperature Coefficient		Note 2		50		ppm/°C
Error Comparator						
Output Leakage Current		$V_{OH} = 30\text{V}$		0.01	1.0	μA
Output Low Voltage	V_{OL}	$V_{IN} = 4.5\text{V}$, $I_{OL} = 400\mu\text{A}$		150	250	mV
Upper Threshold Voltage	V_{THH}	Note 7	40	60		mV
Lower Threshold Voltage	V_{THL}	Note 7		75	95	mV
Hysteresis	Hys	Note 7		15		mV
Shutdown Input						
Input Logic Voltage	V_{SL}	Regulator ON		1.3	0.7	V
	V_{SH}	Regulator OFF	2			
Shutdown Pin Input Current		$V_{SHUTDOWN} = 2.4\text{V}$		30	50	μA
		$V_{SHUTDOWN} = 30\text{V}$		450	600	μA
Regulator Output Current in Shutdown		Note 8		3	10	μA

Note 2: Output or reference voltage temperature coefficients defined as the worst case voltage change divided by the total temperature range.

Note 3: Regulation is measured at constant junction temperature using pulse testing with a low duty cycle. Changes in output voltage due to heating effects are covered under the specification for thermal regulation.

Note 4: Dropout voltage is defined as the input to output differential at which the output voltage drops 100mV below its nominal value measured at 1V differential. At very low values of programmed output voltage, the minimum input supply voltage of 2V (2.3V over temperature) must be taken into account

Note 5: These parameters, although guaranteed, are not tested in production.

Note 6: Thermal regulation is defined as the change in output voltage at a time T after a change in power dissipation is applied, excluding load or line regulation effects. Specifications are for a 50mA load pulse at $V_{IN} = 30\text{V}$ (1.25W pulse) for $T = 10\text{ms}$.

Note 7: Comparator thresholds are expressed in terms of a voltage differential at the feedback terminal below the nominal reference voltage measured at $V_{IN} = V_{OUT} + 1\text{V}$. To express these thresholds in terms of output voltage change, multiply by the error amplifier gain = $V_{OUT}/V_{REF} = (R1 + R2)/R2$. For example, at a programmed output voltage of 5V, the Error output is guaranteed to go low when the output drops by $95\text{mV} \times 5\text{V}/1.235\text{V} = 384\text{mV}$. Thresholds remain constant as a percent of V_{OUT} as V_{OUT} is varied, with the dropout warning occurring at typically 5% below nominal, 7.5% guaranteed.

Note 8: $V_{SHUTDOWN} \geq 2\text{V}$, $V_{IN} = 30\text{V}$, $V_{OUT} = 0$, Feedback connected to V_{TAP}

AMC2950/2951

100mA LOW DROPOUT VOLTAGE REGULATORS

APPLICATION INFORMATION

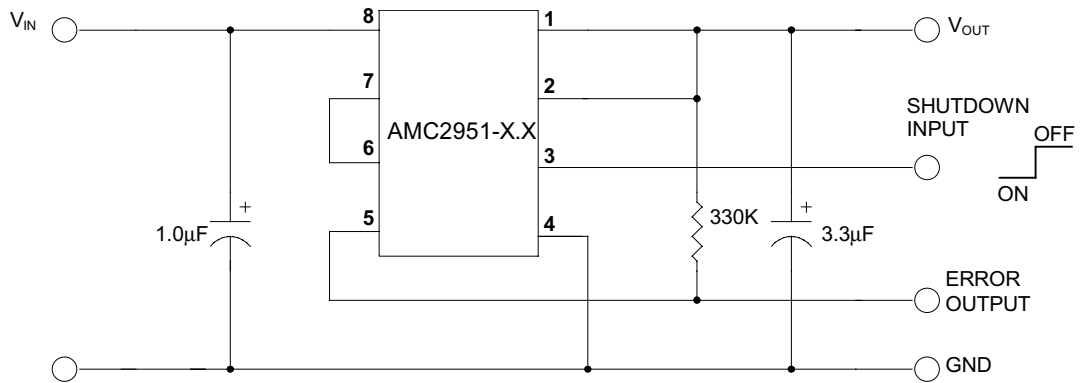

Figure 1. AMC2951-X.X for fixed output application

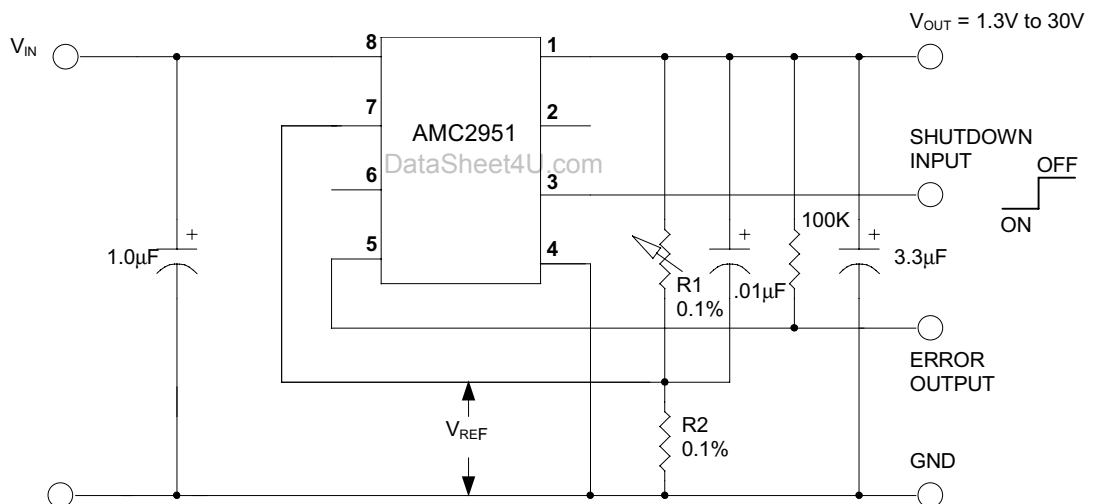

Figure 2. AMC2951 for adjustable output application

The AMC2951 may be pin-strapped for the nominal fixed output voltage with the internal voltage divider by connecting the OUTPUT and SENSE pins together, and also connecting the FEEDBACK and VTAP pins together.

For the adjustable output voltage applications, the AMC2951 can be programmed for any output voltage between 1.235V and 30V by two external resistors. The output voltage follows the equation below:

$$V_{OUT} = V_{REF} \times \left(1 + \frac{R_1}{R_2} \right) + I_{FB}R_1$$

Where V_{REF} is the reference voltage of 1.235V and I_{FB} is the feedback pin bias current, typically -20nA . The minimum recommended load current of $1\mu\text{A}$ forces an upper limit of $1.2\text{M}\Omega$ for R_2 , if the regulator must work with no load.

I_{FB} will introduce a 2% typical error in V_{OUT} , which can be eliminated by trimming R_1 at room temperature. For better accuracy, choosing $R_2 = 100\text{K}$ reduces this error to 0.17%.

AMC Doc. #: AMC2951_A

November 2001

AMC2950/2951

100mA LOW DROPOUT VOLTAGE REGULATORS

3-Pin Plastic TO-92

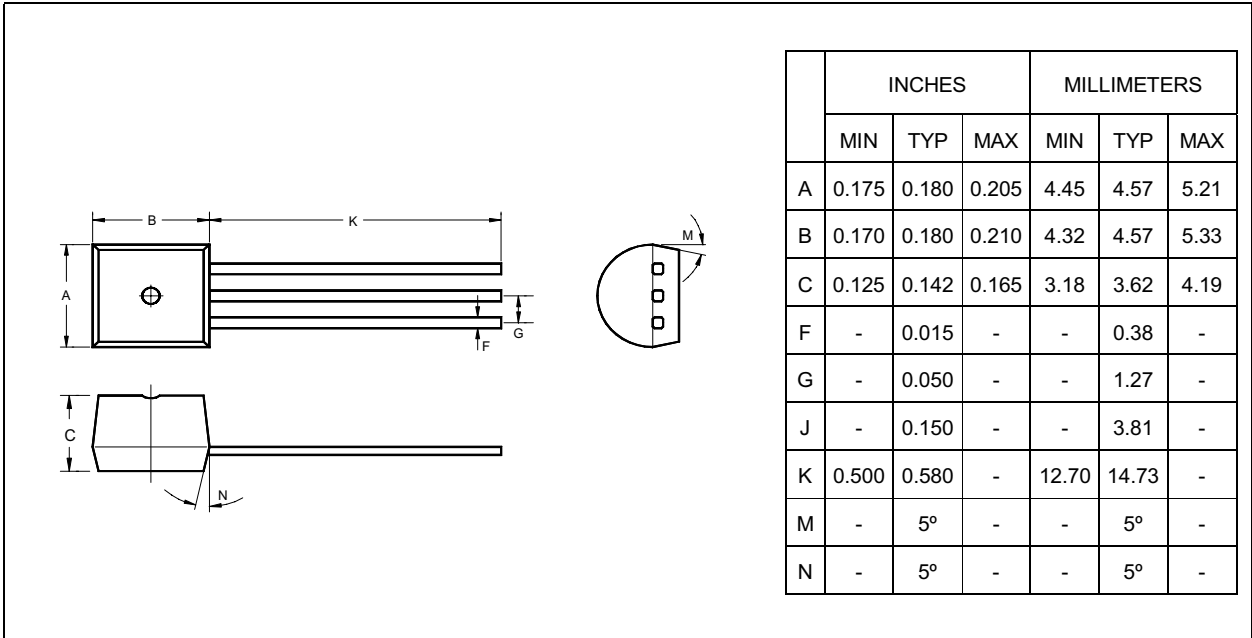

et4U.com

DataSheet4U.com

DataShe

3-Pin Plastic TO-92 Carrier Dimensions

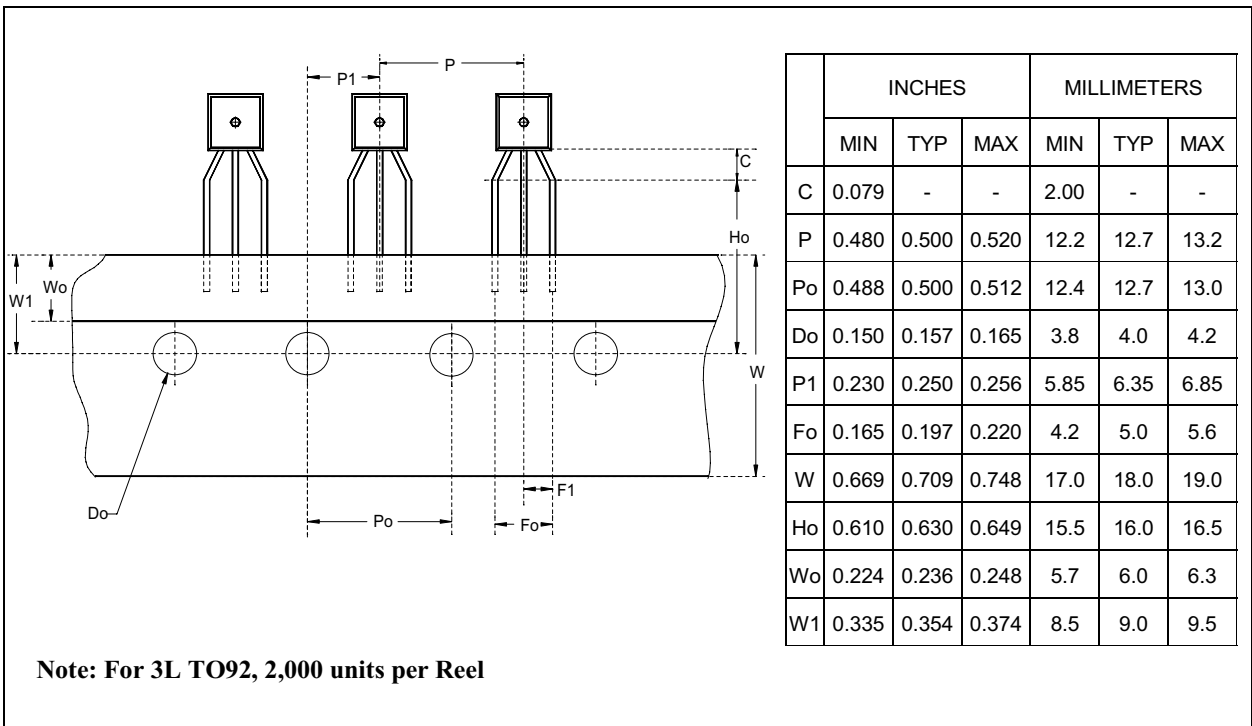

AMC Doc. #: AMC2951_A

November 2001

AMC2950/2951

100mA LOW DROPOUT

VOLTAGE REGULATORS

8-Pin Plastic S.O.I.C.

	INCHES			MILLIMETERS		
	MIN	TYP	MAX	MIN	TYP	MAX
A	0.183	-	0.202	4.65	-	5.13
B	0.144	-	0.163	3.66	-	4.14
C	0.068	-	0.074	1.73	-	1.88
D	0.010	-	0.020	0.25	-	0.51
F	0.015	-	0.035	0.38	-	0.89
G	0.050 BSC			1.27 BSC		
J	0.007	-	0.010	0.19	-	0.25
K	0.005	-	0.010	0.13	-	0.25
L	0.189	-	0.205	4.80	-	5.21
M	-	-	8°	-	-	8°
P	0.228	-	0.244	5.79	-	6.20

Note: for 8 pin S.O.I.C., 100 units per tube, 10,000 units per box

AMC Doc. #: AMC2951_A

November 2001

AMC2950/2951
100mA Low DROPOUT
VOLTAGE REGULATORS

IMPORTANT NOTICE

ADD Microtech (ADDM) reserves the right to make changes to its products or to discontinue any integrated circuit product or service without notice, and advises its customers to obtain the latest version of relevant information to verify, before placing orders, that the information being relied on is current.

A few applications using integrated circuit products may involve potential risks of death, personal injury, or severe property or environmental damage. ADDM integrated circuit products are not designed, intended, authorized, or warranted to be suitable for use in life-support applications, devices or systems or other critical applications. Use of ADDM products in such applications is understood to be fully at the risk of the customer. In order to minimize risks associated with the customer's applications, the customer should provide adequate design and operating safeguards.

ADDM assumes no liability to customer product design or application support. ADDM warrants the performance of its products to the specifications applicable at the time of sale.

et4U.com

DataSheet4U.com

U.S.**ADD Microtech Inc.**

492 Altamont Drive
 Milpitas, CA 95035

TEL: (408) 9410420

FAX: (408) 9410864

Asia Pacific region**ADD Microtech Corp**

3F, No.132, Sec. 4, Chung Hsiao E. Road,
 Taipei, Taiwan

TEL: 2-27760166

FAX: 2-27764208