

1.5A POWER LED DRIVER

DESCRIPTION

AMC7150 is a PWM power LED driver IC. The driving current from few milliamps up to 1.5A. It allows high brightness power LED operating at high efficiency from 4Vdc to 40Vdc. Up to 200KHz external controlled operation frequency. External resistor controlled the maximum output current to single LED or a LED string.

FEATURES

- Only 5 external components required.
- Output driving peak current up to 1.5A.
- 4V ~ 40V wide operation voltage range.
- ESD protection HBM 2KV
- TO-252 5-pin power package.

TYPICAL APPLICATION

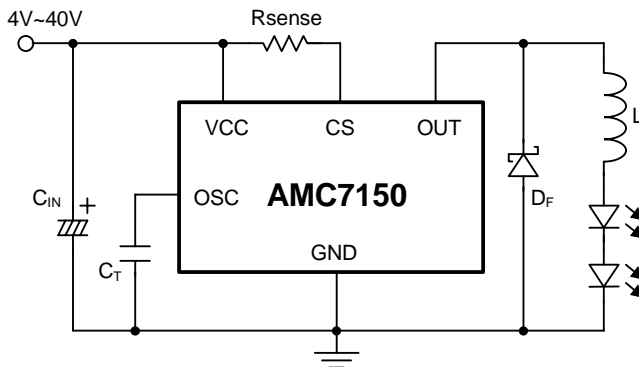

APPLICATIONS

- DC/DC LED driver
- Automotive Lighting
- Decorative Lighting
- MR16

PACKAGE PIN OUT

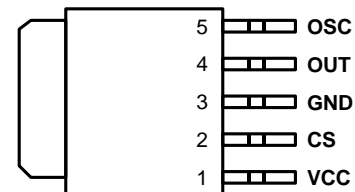

TO-252-5L (Top View)

ORDER INFORMATION

Current Sense Voltage ($V_{CC} - V_{CS}$)	DL	TO-252 5-pin
300 ~ 360mV		AMC7150DLF
300 ~ 320mV		AMC7150ADLF
320 ~ 340mV		AMC7150BDLF
340 ~ 360mV		AMC7150CDLF

Note: 1. All surface-mount packages are available in Tape & Reel. Append the letter "T" to part number (i.e. AMC7150DLFT).
 2. The letter "F" is marked for Lead Free process.

POWER DISSIPATION TABLE

Package	θ_{JA} ($^{\circ}\text{C W}$)	Derating factor (mW/ $^{\circ}\text{C}$) $T_A \geq 25^{\circ}\text{C}$	$T_A \leq 25^{\circ}\text{C}$ Power rating (mW)	$T_A = 70^{\circ}\text{C}$ Power rating (mW)	$T_A = 85^{\circ}\text{C}$ Power rating (mW)
DLF	80	12.5	1560	1000	812

Note :

Junction Temperature Calculation: $T_J = T_A + (P_D \times \theta_{JA})$.

P_D : Power Dissipation, T_A : Ambient temperature, θ_{JA} : Thermal Resistance-Junction to Ambient

The θ_{JA} numbers are guidelines for the thermal performance of the device/PC-board system.

All of the above assume no ambient airflow.

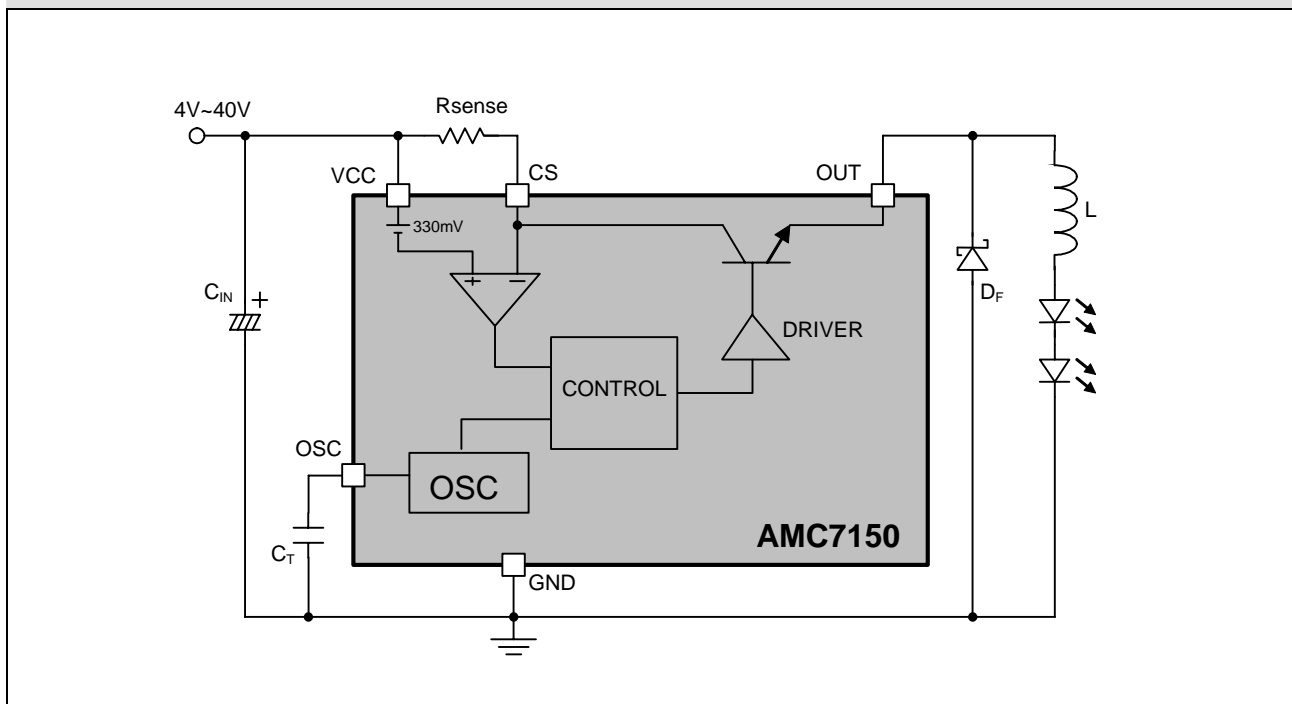
BLOCK DIAGRAM

PIN DESCRIPTION

Pin Number	Pin Name	Pin Function
1	VCC	Input Voltage 4V ~ 40V
2	CS	Peak current senses pin.
3	GND	Ground
4	OUT	Driver output pin.
5	OSC	Oscillator timing capacitor.

ABSOLUTE MAXIMUM RATINGS

Input Voltage, VCC	-0.3V to 40V
Output Voltage, OUT	-0.3V to 40V
Maximum Junction Temperature, T _J	150°C
Storage Temperature Range	-40°C to 150°C
Lead Temperature (soldering, 10 seconds)	260°C

Note:

Exceeding these ratings could cause damage to the device. All voltages are with respect to Ground.
Currents are positive into, negative out of the specified terminal.

RECOMMENDED OPERATING CONDITIONS

Parameter	Symbol	Min	Typ	Max	Unit
Supply Voltage	VCC	4		40	V
Output current	I _{OUT}			1.5	A
Operating free-air temperature range	T _a	-40		85	°C

ELECTRICAL CHARACTERISTICS

VCC=5V, T _A =25°C. (Unless otherwise noted)							
Parameter	Symbol	Condition	Min	Typ	Max	Unit	Apply Pin
Supply Current	I _{CC}	VCC=4~40V			4	mA	VCC
Output Drop-out Voltage	V _{DP}	I _{OUT} =1A, V _{CS} -V _{OUT}		1	1.31	V	OUT
Output Off Current	I _{OFF}	V _{CS} -V _{OUT} = 40V		200	300	μA	
Current Sense Voltage	V _{CC} -V _{CS}	AMC7150	300	330	360	mV	CS
		AMC7150A	300	310	320	mV	
		AMC7150B	320	330	340	mV	
		AMC7150C	340	350	360	mV	
Maximum duty cycle	T _{DC}	V _{CS} =VCC		85		%	OSC
OSC Charge Current	I _{CH}			35		uA	

APPLICATION INFORMATION
Low Voltage DC/DC Application

The AMC7150 was designed for power LED driving application. Only 5 external components were required for low voltage application. Fig.1 shows the typical application circuit for input voltage range from 4V to 40V. Buck power conversion topology was used and total forward voltage (at expecting current) of the LED string should lower than supply voltage by 1.6V at least.

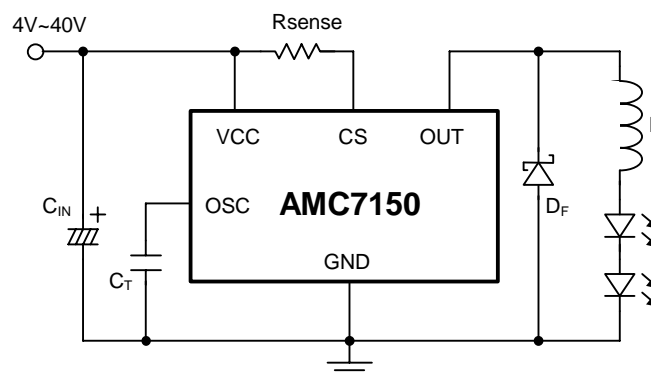
Input Bypass Capacitor

The input by-pass capacitor C_{IN} holds the input voltage and filters out the switching noise of AMC7150.

Flywheel Diode

The fast recovery diode was recommended for flywheel diode D_F . This is because the high reverse recovery current will cause the voltage drop across R_{sense} being higher than 330mV, and consequently the switch will be turned off which has just been turned on.

LED Driving Current

The peak current I_{PK} flow though LEDs was decided by:

$$I_{PK} = \frac{330mV}{R_{sense}}$$

The average current on LEDs was determined by the peak-to-peak ripple current that was decided by inductor L. Assume the target average current 550mA on LEDs and ripple current 100mA then the R_{sense} should be:

$$R_{sense} = \frac{330mV}{550mA + 0.5 \cdot 100mA} = 0.55\Omega$$

The R_{sense} value should higher than $200m\Omega$ so that driving current won't over the recommended maximum driving current 1.5A.

Inductor

The Inductor L stores energy during switch turn-on period and discharge driving current to LEDs via flywheel diode while switch turn-off. In order to reduce the current ripple on LEDs, the L value should high enough to keep the system working at continuous-conduction mode that inductor current won't fall to zero.

Since in steady-state operation the waveform must repeat from one time period to the next, the integral of the inductor voltage v_L over one time period must be zero:

$$\int_0^{T_s} v_L dt = \int_0^{t_{ON}} v_L dt + \int_{t_{ON}}^{T_s} v_L dt = 0 \quad \text{Where } T_s = t_{ON} + t_{OFF}$$

Therefore

$$\frac{t_{ON}}{t_{OFF}} = \frac{V_{LED} + V_F}{V_{CC} - V_{Rsense} - V_{SAT} - V_{LED}}$$

Where, V_{LED} is the total forward voltage (at expecting current) of the LED string, V_F is the forward voltage of the flywheel diode D_F , V_{Rsense} is the peak value of the voltage drop across R_{sense} which is 300mV, and V_{SAT} is the saturation voltage of the switch which has a typical value of 1V.

Since the operation frequency f is determined by choosing appropriate value for timing capacitor C_T , the switch turn-on time can also be known by

$$t_{ON} = D \cdot T_s = \frac{D}{f} \quad \text{Where } D(\text{Dutycycle}) = \frac{t_{ON}}{t_{ON} + t_{OFF}}$$

With knowledge of the peak switch current and switch on time, the value of inductance can be calculated.

$$L = \frac{V_{CC} - V_{Rsense} - V_{SAT} - V_{LED}}{I_{PK}} \cdot t_{ON}$$

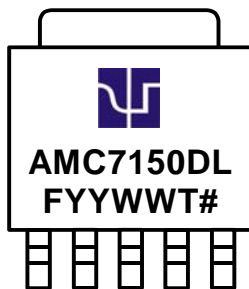
PACKAGE
Top Marking for TO-252-5L

F : Lead Free
YY : Year Code
WW : Week Code
T : Trace Code
: Rank of Current Sense Voltage

Blank = 300 ~ 360mV (No Rank);

A = 300 ~ 320mV (Rank A);

B = 320 ~ 340mV (Rank B);

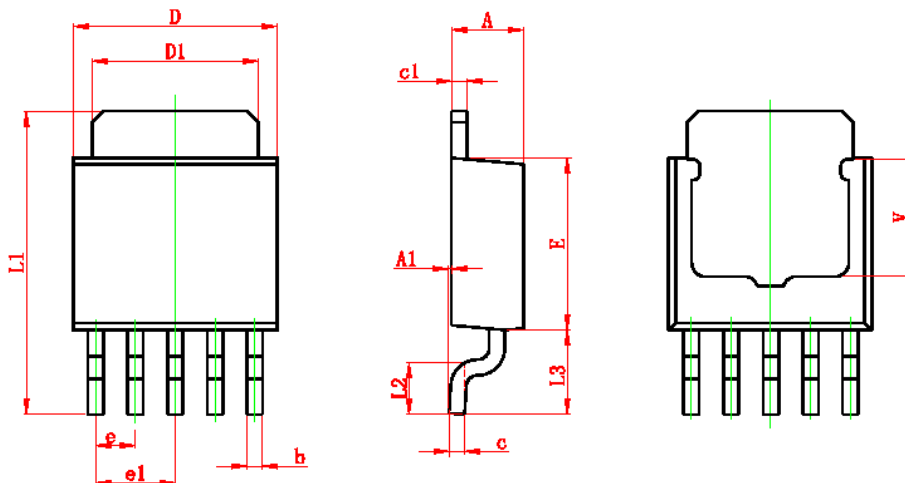
C = 340 ~ 360mV (Rank C);

5-Pin Surface Mount TO-252 (DL)

Symbol	Dimensions in Millimeters		Dimensions in Inches	
	MIN	MAX	MIN	MAX
A	2.200	2.400	0.087	0.094
A1	0.000	0.127	0.000	0.005
B	0.400	0.600	0.016	0.024
C	0.430	0.580	0.017	0.023
c1	0.430	0.580	0.017	0.023
D	6.350	6.650	0.250	0.262
D1	5.200	5.400	0.205	0.213
E	5.400	5.700	0.213	0.224
E	1.270 TYP		0.050 TYP	
e1	2.540 TYP		1.000 TYP	
L1	9.500	9.900	0.374	0.390
L2	1.400	1.780	0.055	0.070
L3	2.550	2.900	0.100	0.114
V	3.800 REF		0.150 REF	

IMPORTANT NOTICE

ADDtek reserves the right to make changes to its products or to discontinue any integrated circuit product or service without notice, and advises its customers to obtain the latest version of relevant information to verify, before placing orders, that the information being relied on is current.

A few applications using integrated circuit products may involve potential risks of death, personal injury, or severe property or environmental damage. ADDtek integrated circuit products are not designed, intended, authorized, or warranted to be suitable for use in life-support applications, devices or systems or other critical applications. Use of ADDtek products in such applications is understood to be fully at the risk of the customer. In order to minimize risks associated with the customer's applications, the customer should provide adequate design and operating safeguards.

ADDtek assumes no liability to customer product design or application support. ADDtek warrants the performance of its products to the specifications applicable at the time of sale.

ADDtek Corp.

9F, No. 20, Sec. 3, Bade Rd., Taipei, Taiwan, 105

TEL: 2-25700299

FAX: 2-25700196
