

AMC7635

300mA CMOS LOW DROP OUT REGULATOR

DESCRIPTION

The AMC7635 of positive, linear regulator features low noise and low dropout voltage, making it ideal for battery applications. The space-saving SOT-23-5 package is attractive for "Pocket" and "Hand Held" applications.

In applications requiring a low noise, regulated supply, place a 1000pF capacitor between Bypass and Ground.

The AMC7635 is stable with an output capacitance of 2.2 μ F or greater.

FEATURES

- **Guaranteed 300mA Output**
- **Accurate to within 1.5%**
- **Very Low Dropout Voltage**
- **Over-Temperature Shutdown**
- **Power-Saving Shutdown Mode**
- **Current Limiting**
- **Noise Reduction Bypass Capacitor**
- **Factory Pre-set Output Voltages**
- **Low Temperature Coefficient**
- **Available in SOT-23-5 packages**

TYPICAL APPLICATION CIRCUIT

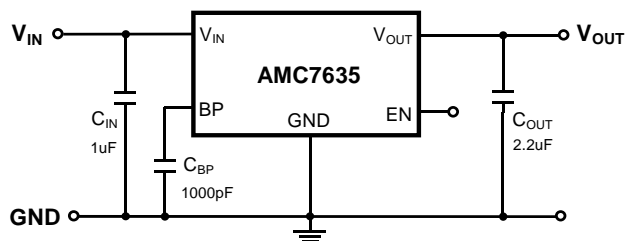

APPLICATIONS

- **Wireless Devices**
- **Portable Electronics**
- **Cordless Phones**
- **PC Peripherals**
- **Battery Powered Widgets**
- **Electronic Scales**
- **Instrumentation**

VOLTAGE OPTIONS

AMC7635-1.5	– 1.5V Fixed
AMC7635-1.8	– 1.8V Fixed
AMC7635-2.0	– 2.0V Fixed
AMC7635-2.5	– 2.5V Fixed
AMC7635-2.8	– 2.8V Fixed
AMC7635-3.0	– 3.0V Fixed
AMC7635-3.1	– 3.1V Fixed
AMC7635-3.3	– 3.3V Fixed
AMC7635	– Adjustable Output

PACKAGE PIN OUT

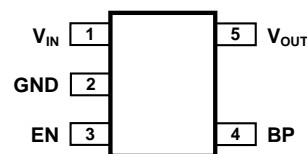

5-Pin Plastic SOT-23-5
Surface Mount
(Top View)

ORDER INFORMATION

T_A (°C)	DB	Plastic SOT-23-5
		5-pin
0 to 70	AMC7635-X.XDBFT (Lead Free)	
Note: 1. All surface-mount packages are available in Tape & Reel. Append the letter "T" to part number (i.e. AMC7635-X.XDBT). Note: 2. The letter "F" is marked for Lead Free process.		

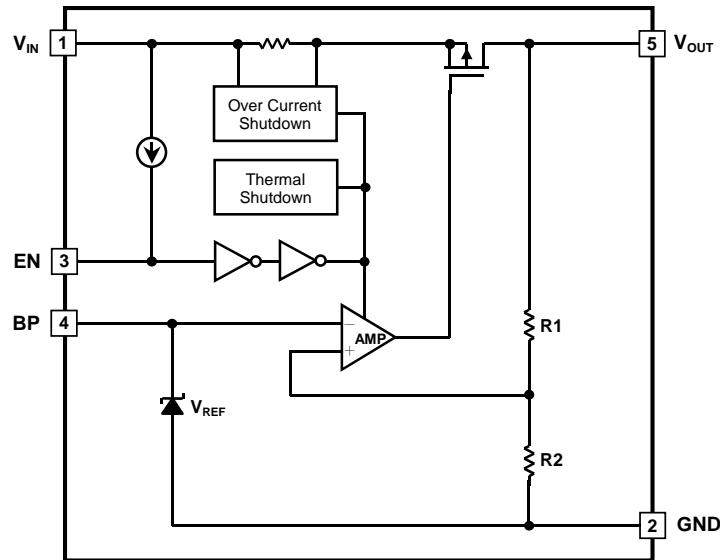
BLOCK DIAGRAM**ABSOLUTE MAXIMUM RATINGS** (Note)

Input Voltage, V_{IN}	7V
Operating Junction Temperature Range, T_J	0°C to 150°C
Storage Temperature Range, T_{STG}	-65°C to 150°C
Lead Temperature (soldering, 10 seconds)	260°C

Note: Exceeding these ratings could cause damage to the device. All voltages are with respect to Ground.
Currents are positive into, negative out of the specified terminal.

POWER DISSIPATION TABLE

DB PACKAGE:	
Thermal Resistance from Junction to Ambient, θ_{JA}	220°C/W
Junction Temperature Calculation: $T_J = T_A + (PD \times \theta_{JA})$.	
The θ_{JA} numbers are guidelines for the thermal performance of the device/pc-board system. Connect the ground pin to ground using a large pad or ground plane for better heat dissipation. All of the above assume no ambient airflow.	

RECOMMENDED OPERATING CONDITIONS

Parameter	Symbol	Min.	Typ.	Max.	Units
Input Voltage	V_{IN}	$V_{OUT} + \Delta V$		6	V
Load Current (with adequate heat-sinking)	I_O	5			mA
Junction temperature	T_J			125	°C

ELECTRICAL CHARACTERISTICS

$V_{IN} = V_{OUT(Nominal)} + 0.5V$, $V_{IN,MAX} = 6V$, $T_A = 25^\circ C$ (unless otherwise noted)							
Parameter	Symbol	Test Conditions	Min	Typ	Max	Units	
Output Voltage Accuracy	V_{OUT}	$I_O = 1mA$	-1.5		+1.5	%	
		$I_O = 1$ to $300mA$	-2.5		+2.5		
Line Regulation	$\frac{\Delta V_{OUT}}{\Delta V_I V_{OUT}}$	$I_O = 1mA$, $V_{OUT} + 0.5V < V_{IN} < 6V$		0.15	0.35	%/V	
Load Regulation	ΔV_{OUT}	$1mA \leq I_O \leq 300mA$		10	70	mV	
Dropout Voltage	ΔV	$I_O = 150mA$, $V_{OUT} = V_{OUT(NOM)} - 2.0\%$	$V_{OUT(NOM)} \leq 2.0V$		330	500	mV
			$2.0V < V_{OUT(NOM)} \leq 2.5V$		220	350	
			$V_{OUT(NOM)} > 2.5V$		165	250	
		$I_O = 300mA$, $V_{OUT} = V_{OUT(NOM)} - 2.0\%$	$V_{OUT} \leq 2.0V$			1300	
			$2.0V < V_{OUT} \leq 2.5V$			900	
			$V_{OUT} > 2.5V$			600	
Maximum Output Current	I_O	$V_{OUT} > 0.96 \times V_{RATING}$	300			mA	
Current Limit	I_{LIMIT}	$V_{OUT} > 1.2V$	300	400			
Ground Pin Current	I_Q	$I_O = 0mA \sim 10mA$		50	100	μA	
		$I_O = 10mA \sim 150mA$		100	150		
		$I_O = 150mA \sim 300mA$		120	180		
Output Shutdown Delay		$C_{BP} = 0\mu F$, $C_{OUT} = 1\mu F$, $I_O = 100mA$		600		μS	
EN "high" Bias Current	I_{IH}	$V_{EN} = V_{IN}$			0.1	μA	
EN "low" Bias Current	I_{IL}	$V_{EN} = 0V$			0.5		
Shutdown Supply Current		$V_{EN} = GND$		0.01	1	μA	
EN "low" Input Threshold	V_{IL}	$V_{IN} = 2.5$ to $5.5V$	0		0.4	V	
EN "high" Input Threshold	V_{IH}	$V_{IN} = 2.5$ to $5.5V$	2		V_{IN}		
Power Supply Rejection Ratio	PSRR	$I_O = 100mA$ $C_{BP} = 0.01\mu F$ $C_{OUT} = 2.2\mu F$	$f = 1kHz$		60	dB	
			$f = 10kHz$		50		
			$f = 100kHz$		40		
Thermal Protection Temperature				150		$^\circ C$	
Thermal Protection Temperature Hysteresis				30			

Note 1: For the adjustable device, the minimum load current is the minimum current required to maintain regulation. Normally the current in the resistor divider used to set the output voltage is selected to meet the minimum load current requirement.

Note 2: These parameters, although guaranteed, are not tested in production.

CHARACTERIZATION CURVES

Unless otherwise specified, $V_{IN} = 5V$, $C_{IN} = 1\mu F$, $C_{BP} = 0.01\mu F$, $C_{OUT} = 2.2\mu F$, $T_A = 25^\circ C$.

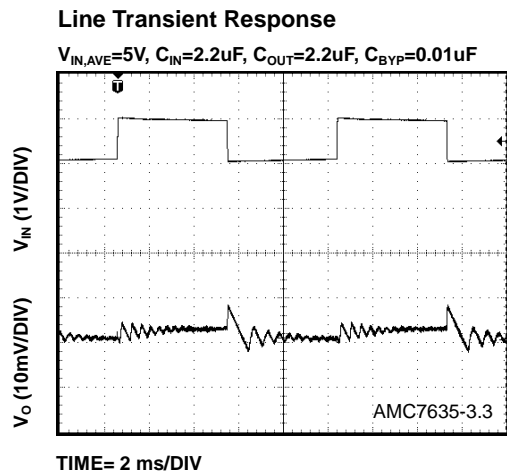
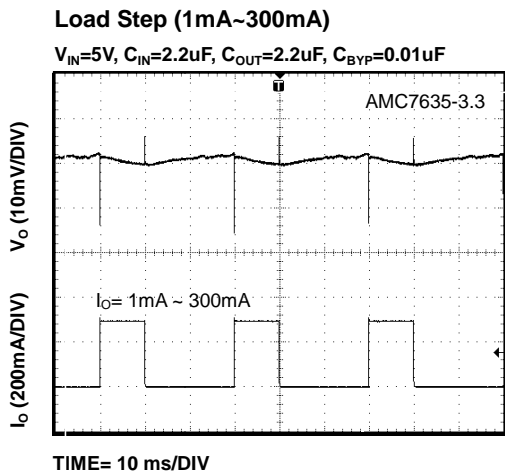
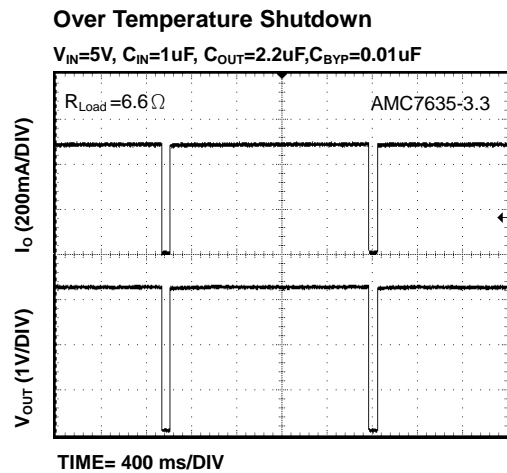
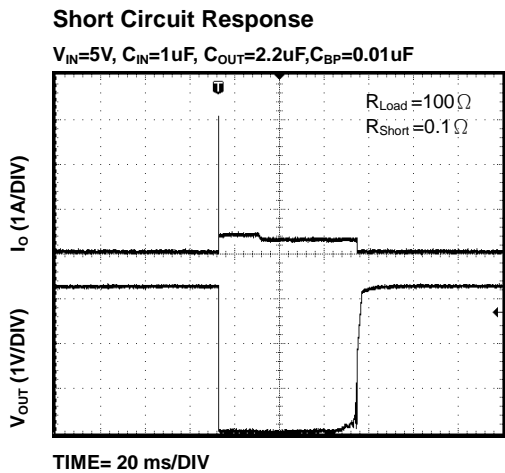
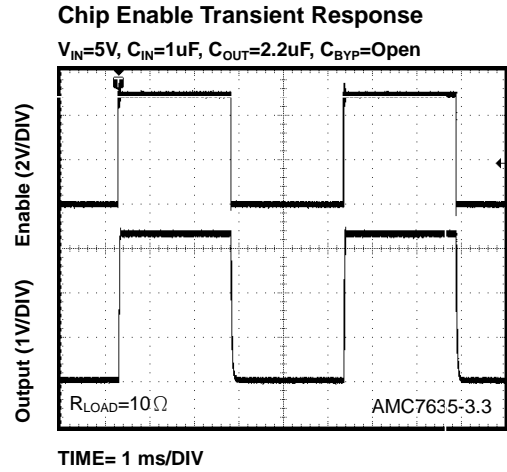
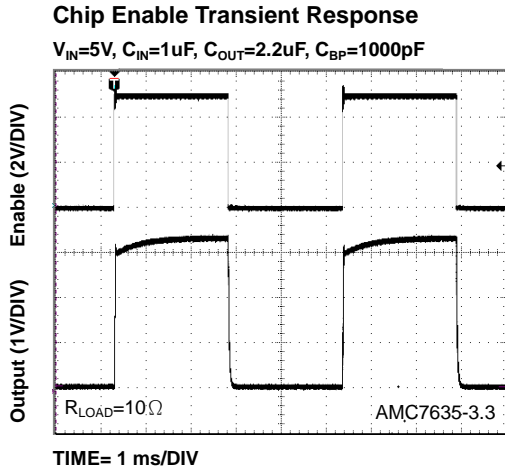

Ground Pin Current vs. Temperature

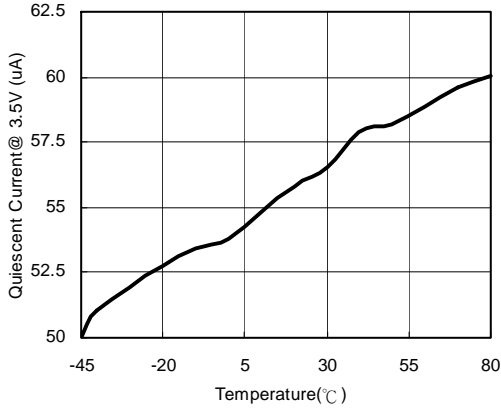

Ground Current vs. Input Voltage

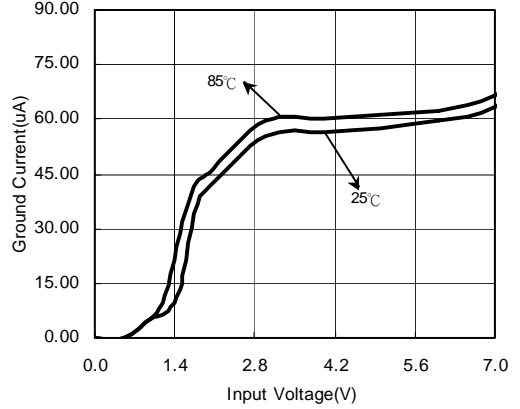

Drop Out Voltage vs. Load Current

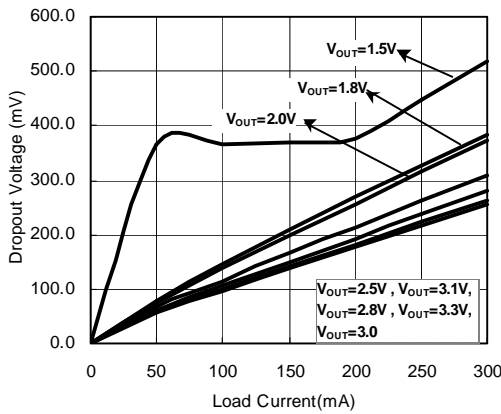

Safe Operating Area

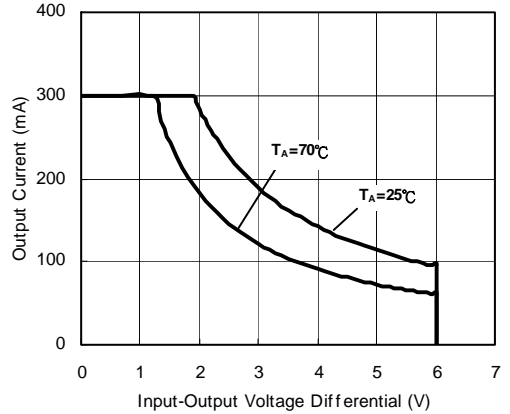

Dropout Voltage vs. Temperature

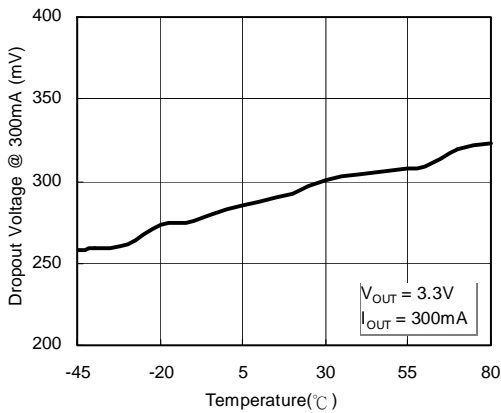

Drop Out Voltage vs. Output Voltage

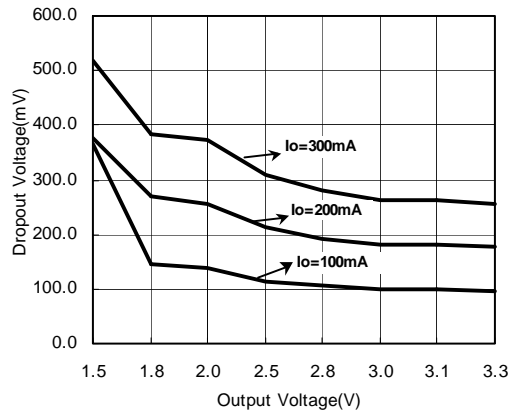

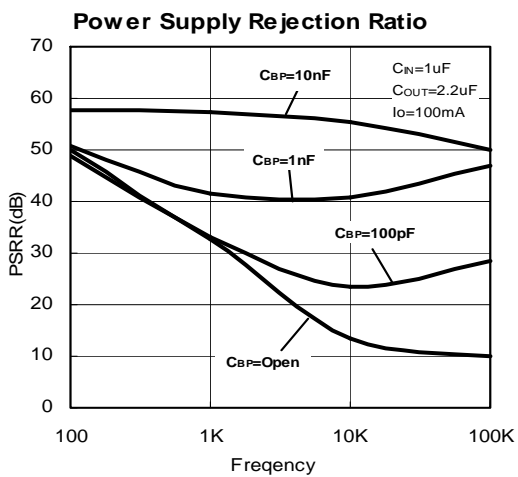
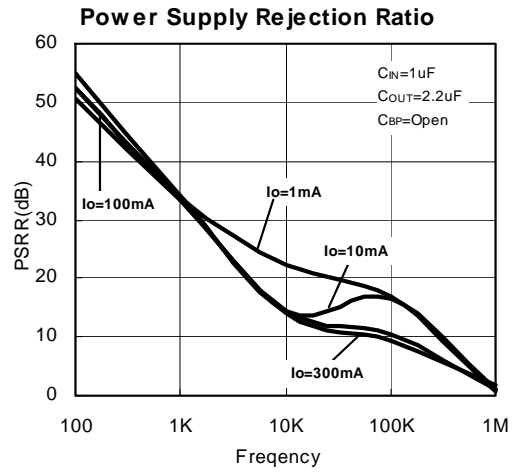
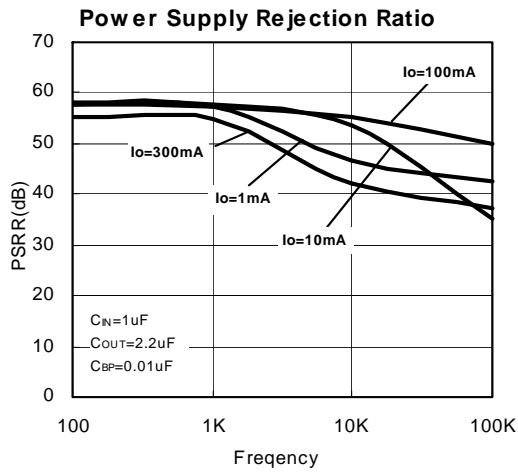

APPLICATION INFORMATION

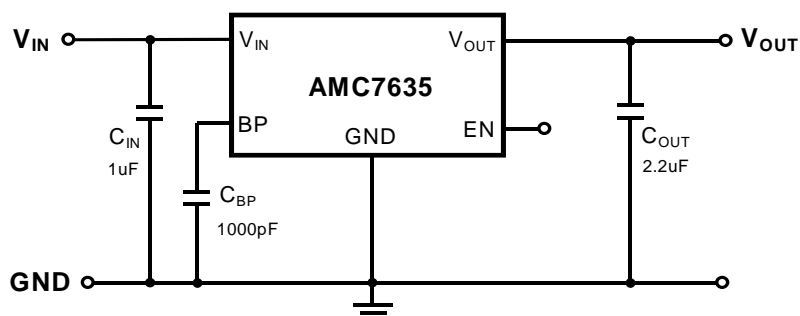

◆ Detailed Description

The AMC7635 CMOS low dropout regulator contains a PMOS pass transistor, a voltage reference, an error amplifier, over-current protection, and thermal shutdown circuit.

The P-channel pass transistor receives data from the error amplifier, over-current shutdown, and thermal protection circuits. During normal operation, the error amplifier compares the output voltage to a precision reference. Thermal shutdown and over-current circuits become active when the junction temperature exceeds 150°C, or the current exceeds 300mA. During thermal shutdown, the output voltage remains low. Normal operation is restored when the junction temperature drops below 120°C.

◆ External Capacitors

The AMC7635 is stable with an output capacitor to ground of 2.2µF or greater. Ceramic capacitors have the lowest ESR, and will offer the best AC performance. Conversely, Aluminum Electrolytic capacitors exhibit the highest ESR, resulting in the poorest AC response. Unfortunately, large value ceramic capacitors are comparatively expensive. One option is to parallel a 0.1µF ceramic capacitor with a 10µF Aluminum Electrolytic. The benefit is low ESR, high capacitance, and low over-all cost.

A second capacitor is recommended between the input and ground to stabilize V_{IN} . The input capacitor should be at least 0.1µF to have a beneficial effect.

A third capacitor can be connected between the BP pin and GND. This capacitor can be a low cost Polyester Film variety between the value of 0.001 ~ 0.01µF. A larger capacitor improves the AC ripple rejection, but also makes the output come up slowly. This "Soft" turn-on is desirable in some applications to limit turn-on surges.

All capacitors should be placed in close proximity to the pins. A "Quiet" ground termination is desirable. This can be achieved with a "Star" connection.

◆ EN

The EN pin is normally pulled to high. When shutdown, pulled low, the PMOS pass transistor shuts off, and all internal circuits are powered down. In this state, the quiescent current is less than 1µA. This pin behaves much like an electronic switch.

PACKAGE

5-Pin SOT-23-5

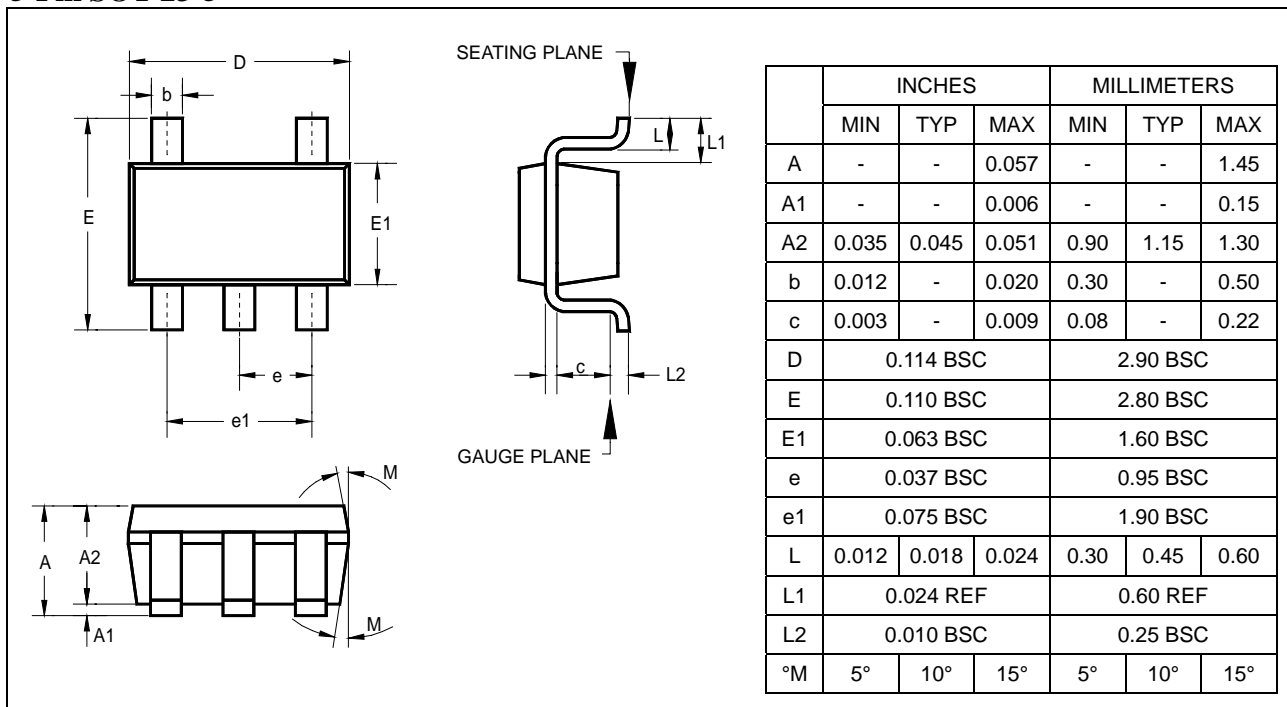



IMPORTANT NOTICE

ADDtek reserves the right to make changes to its products or to discontinue any integrated circuit product or service without notice, and advises its customers to obtain the latest version of relevant information to verify, before placing orders, that the information being relied on is current.

A few applications using integrated circuit products may involve potential risks of death, personal injury, or severe property or environmental damage. ADDtek integrated circuit products are not designed, intended, authorized, or warranted to be suitable for use in life-support applications, devices or systems or other critical applications. Use of ADDtek products in such applications is understood to be fully at the risk of the customer. In order to minimize risks associated with the customer's applications, the customer should provide adequate design and operating safeguards.

ADDtek assumes no liability to customer product design or application support. ADDtek warrants the performance of its products to the specifications applicable at the time of sale.

ADDtek Corp.
9F, No. 20, Sec. 3, Bade Rd., Taipei, Taiwan, 105
TEL: 2-25700299
FAX: 2-25700196
