

DESCRIPTION

The AMC7660 is designed for the applications which require DC - DC converters. It can be operated in a wide input range from 3.0V to 40V and has the controlled duty cycle oscillator, driver and high current output switch. Also, With the internal temperature compensation circuit, the AMC7660 provides an internally trimmed precision 1.5% reference voltage of 1.25V. These features make the AMC7660 suitable for step-up, step-down and voltage-inverting applications.

FEATURES

- Internally trimmed 1.5% 1.25V Reference Voltage
- Wide Input Operating Range: 3.0V to 40V
- Output Switch Current up to 1.5A
- Low Standby Current
- 100KHz operational Frequency
- Adjustable Output Voltage
- Available in 8 Pin Plastic DIP and 8 Pin S.O Packages

APPLICATIONS

- Automobile Chargers
- Adaptors
- Mother Board
- External Modem
- ISDN Modem
- Scanner
- Cellular Phones/Radios
- Laptop/Notebook

PACKAGE PIN OUT

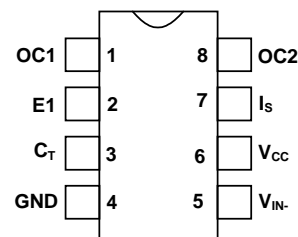

M PACKAGE

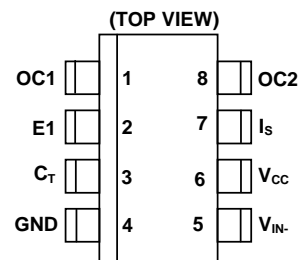

DM PACKAGE

(TOP VIEW)

ORDER INFORMATION

T_A (°C)	M	Plastic DIP 8-pin	DM	Plastic SO-8 8-pin
0 to 70		AMC7660M		AMC7660DM
0 to 70		AMC7660MF(Lead Free)		AMC7660DMF(Lead Free)
Note: 1.All surface-mount packages are available in Tape & Reel. Append the letter "T" to part number (i.e. AMC7660DMT). 2.The letter "F" is marked for Lead Free process.				



AMC7660

ABSOLUTE MAXIMUM RATINGS

Power Supply Voltage (V_{CC})	40V
Operating Junction temperature	
Plastic (M, DM Package)	150°C
Storage Temperature Range	-65°C to 150°C
Lead temperature (Soldering, 10 seconds)	300°C

Note 1: Exceeding these ratings could cause damage to the device. All voltages are with respect to Ground. Currents are positive into, negative out of the specified terminal.

THERMAL DATA

M PACKAGE:	
Thermal Resistance-Junction to Ambient, θ_{JA}	95°C/W
DM PACKAGE:	
Thermal Resistance-Junction to Ambient, θ_{JA}	165°C/W

BLOCK DIAGRAM

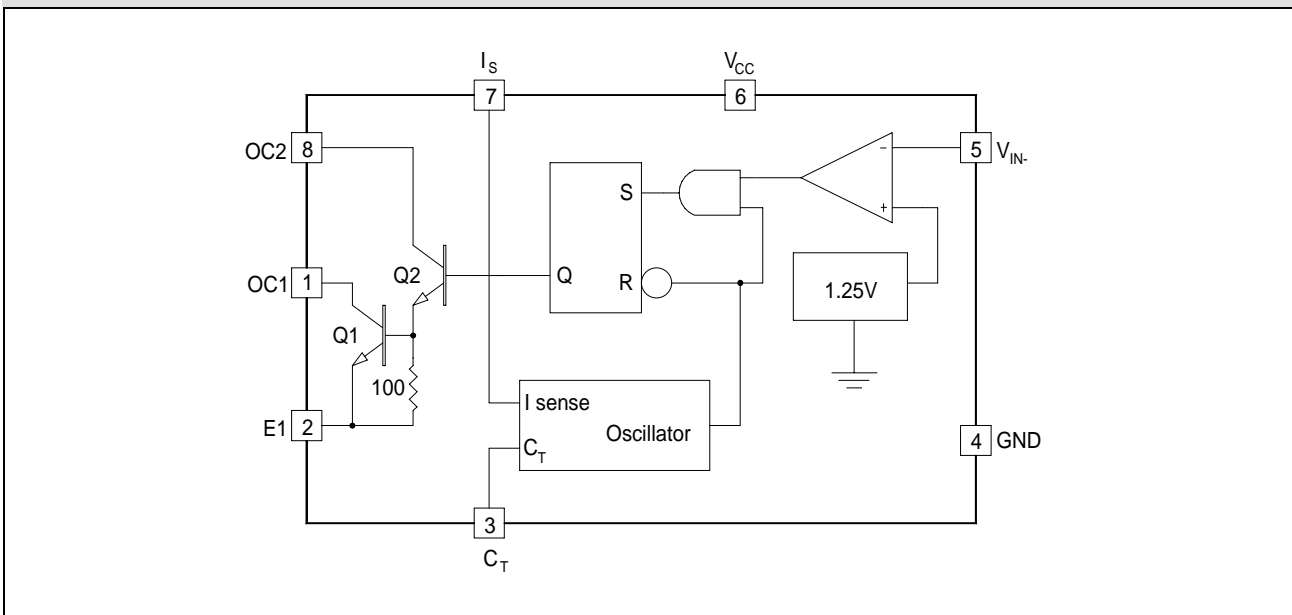



AMC7660

RECOMMENDED OPERATING CONDITIONS

Parameter	Symbol	Recommended Operating			Units
		Min.	Typ.	Max.	
Comparator Input Voltage	V_{IR}	-0.3 to +40			V
Switch Collector Voltage	V_{OC1}			40	V
Switch Emitter Voltage ($V_{Pin1}=40V$)	V_{E1}			40	V
Switch Collector to Emitter Voltage	V_{CE1}			40	V
Driver Collector Voltage	V_{C2}			40	V
Driver Collector Current (Note 1)	I_{C2}			100	mA
Switch Current	I_{SWITCH}			1.5	A
Oscillator Timing Capacitor (connected to C_T pin)	C_T		1.0		nF
Operating Ambient Temperature Range	T_A	0 to +70			°C

Note 1: Maximum package power dissipation limits must be observed.

ELECTRICAL CHARACTERISTICS

$V_{CC}=5.0$ V, $T_A=0^{\circ}\text{C}$ to 70°C , unless otherwise specified.

Parameter	Symbol	Test Conditions	AMC7660			Units
			Min.	Typ.	Max.	
OSCILLATOR						
Frequency	F_{osc}	$V_{IN-} = 0$ V, $C_T = 1.0$ nF, $T_A = 25^{\circ}\text{C}$	24	33	42	KHz
Charge Current	I_{chg}	$V_{CC} = 5.0$ V to 40 V, $T_A = 25^{\circ}\text{C}$	24	35	42	μA
Discharge Current	I_{dischg}	$V_{CC} = 5.0$ V to 40 V, $T_A = 25^{\circ}\text{C}$	140	220	260	μA
Discharge to Charge Current Ratio	I_{dischg}/I_{chg}	I_S to V_{CC} , $T_A = 25^{\circ}\text{C}$	5.2	6.5	7.5	-
Current Limit Sense Voltage	V_{IS}	$I_{chg} = I_{dischg}$, $T_A = 25^{\circ}\text{C}$	250	300	350	mV
OUTPUT SWITCH						
Saturation Voltage, Darlington Connection	$V_{CE1(sat)}$	$I_{SW} = 1.0$ A, OC1, OC2 connected	-	0.9	1.3	V
Saturation Voltage	$V_{CE1(sat)}$	$I_{SW} = 1.0$ A, 82 Ω connected from OC2 to V_{CC} , Forced $\beta = 20$	-	0.4	0.7	V
DC Current Gain	h_{FE}	$I_{SW} = 1.0$ A, $V_{CE} = 5.0$ V, $T_A = 25^{\circ}\text{C}$	50	75	-	-
Collector Off – State Current	$I_{C(off)}$	$V_{CE} = 40$ V	-	0.01	100	μA
COMPARATOR						
Threshold Voltage	V_{th}	$T_A = 25^{\circ}\text{C}$	1.23	1.25	1.27	V
		$T_A = 0^{\circ}\text{C}$ to 70°C	1.22	-	1.28	
Threshold Voltage Line Regulation	$V_{th(line)}$	$V_{CC} = 3.0$ V to 40 V	-	1.4	5.6	mV
Input Bias Current	I_{IB}	$V_{IN-} = 0$ V	-	-20	-400	nA
TOTAL DEVICE						
Supply current	I_{CC}	$V_{CC} = 5.0$ V to 40 V, $C_T = 1.0$ nF, Pin 7 = V_{CC} , $V_{IN-} > V_{th}$, Pin 2= Gnd, remaining pins open	-	3.0	3.9	mA



CHARACTERIZATION CURVES

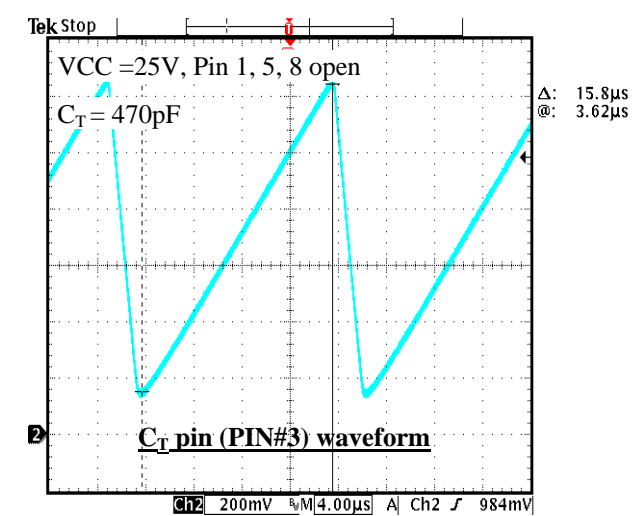
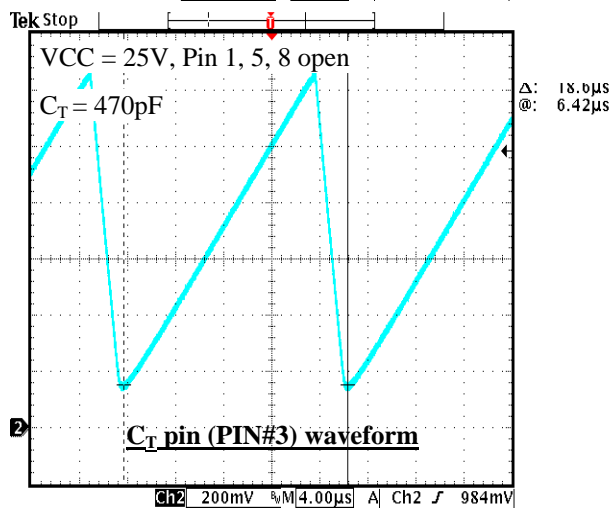
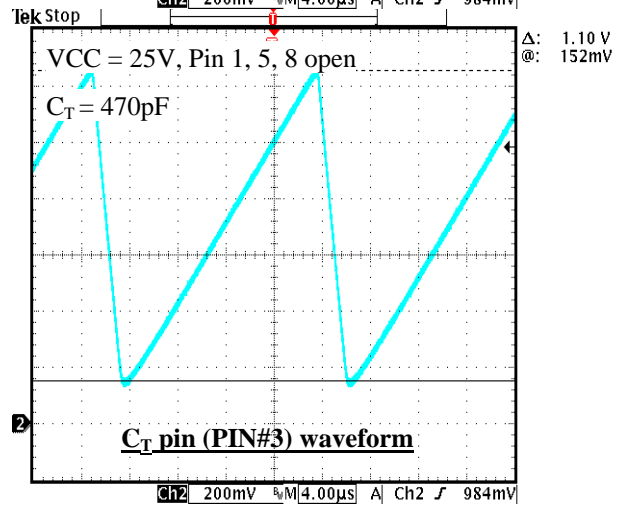
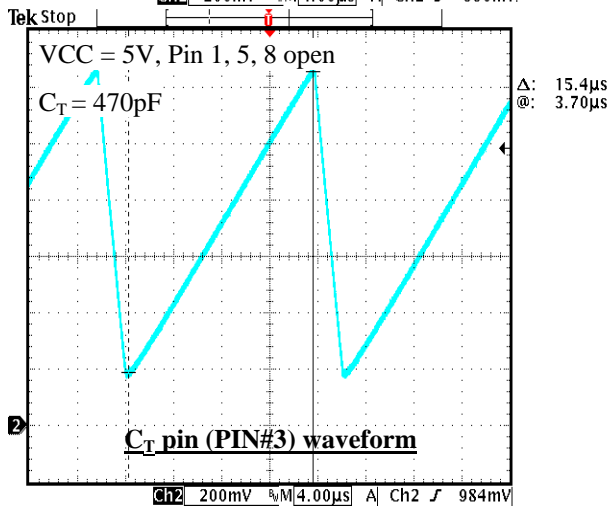
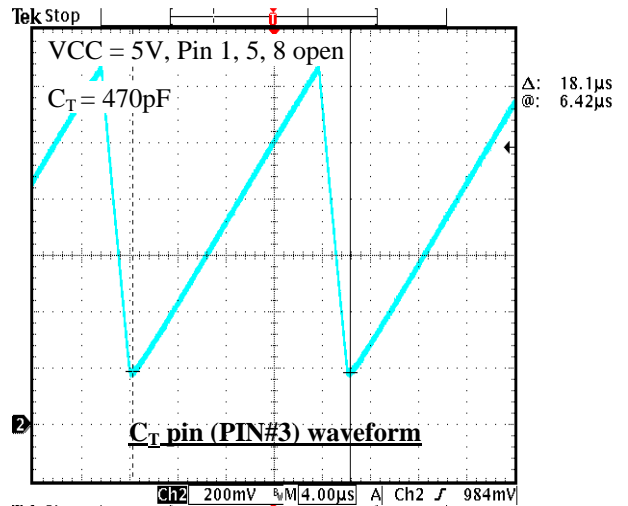
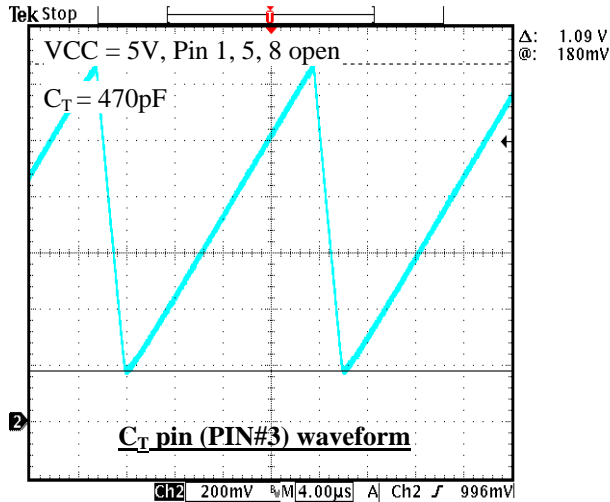



CHARACTERIZATION CURVES

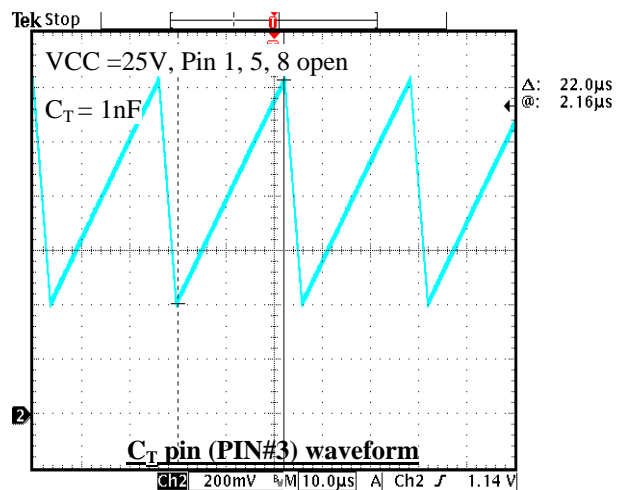
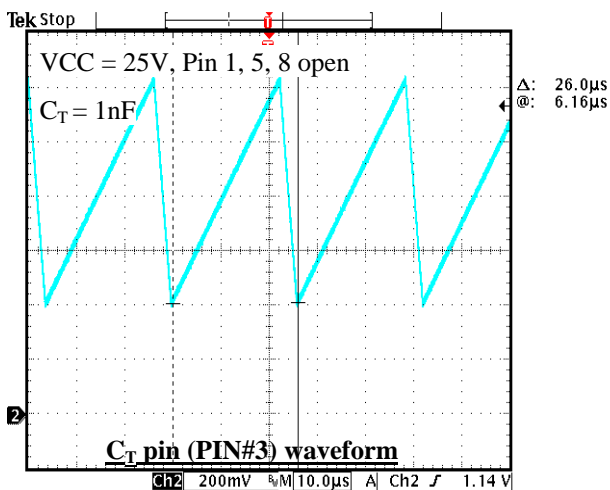
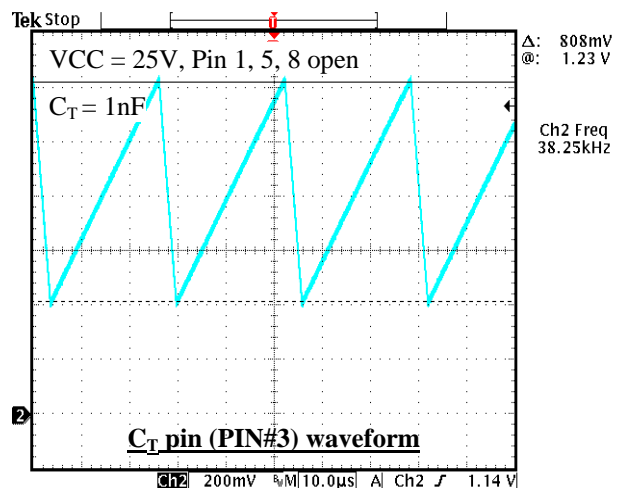
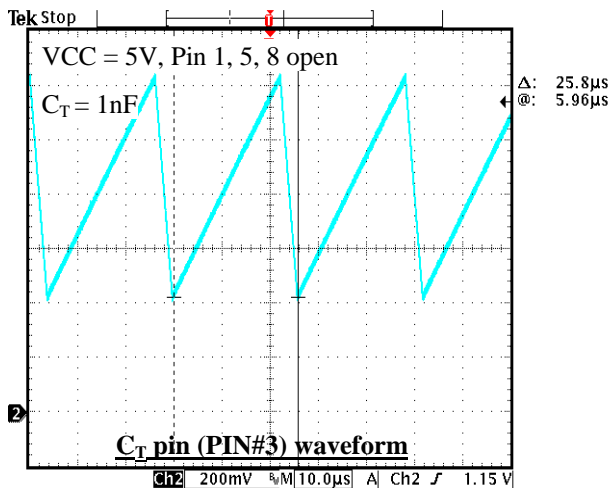
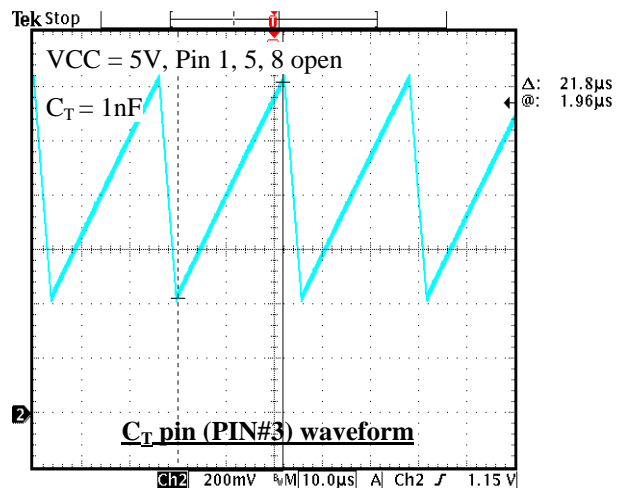
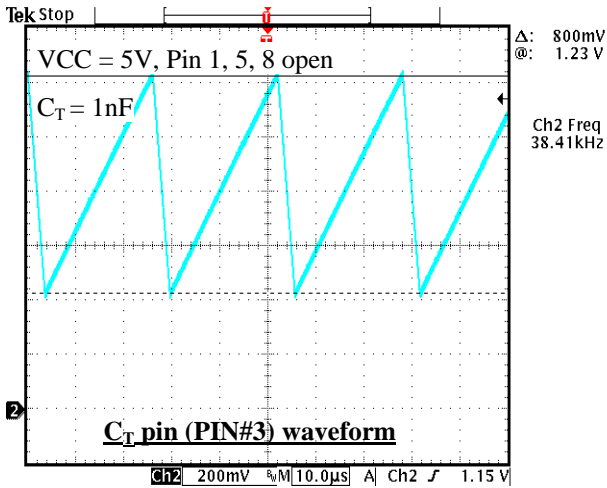



CHARACTERIZATION CURVES

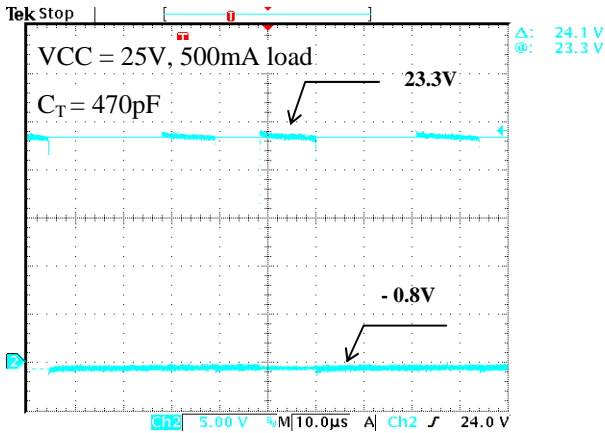

E1 pin (PIN#2) waveform
on 5V step down converter

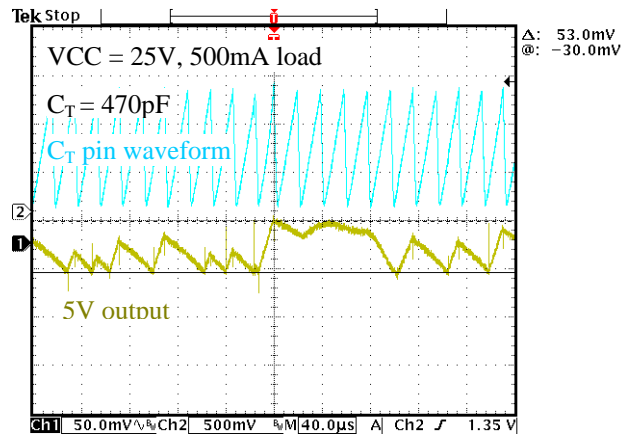

Step down 5V output performance

Figure 1 – Step-Up Converter Application Circuits

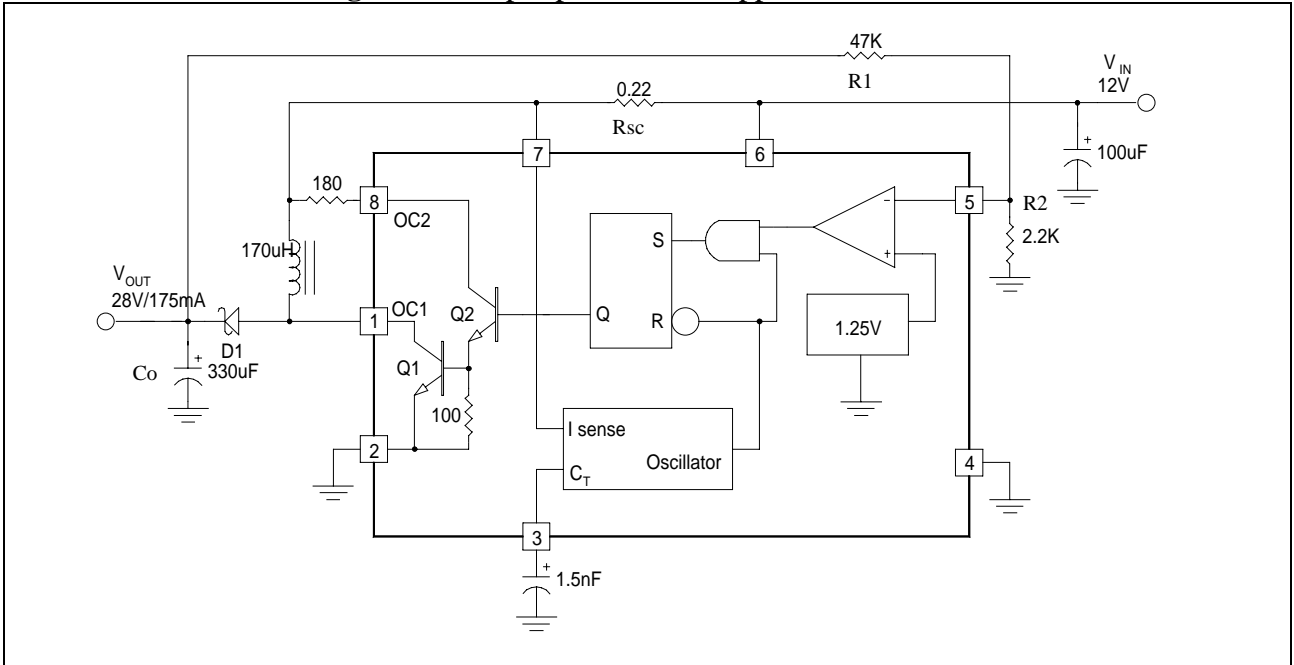

Figure 2 – Step-Down Converter Application Circuit

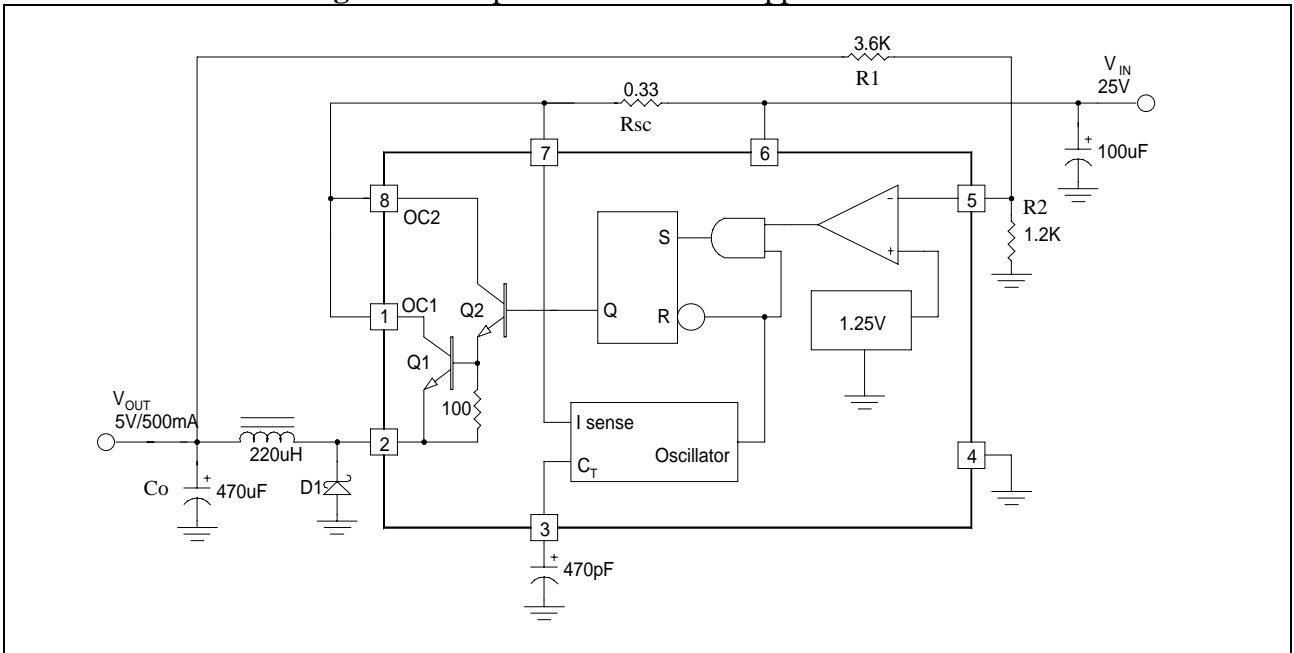
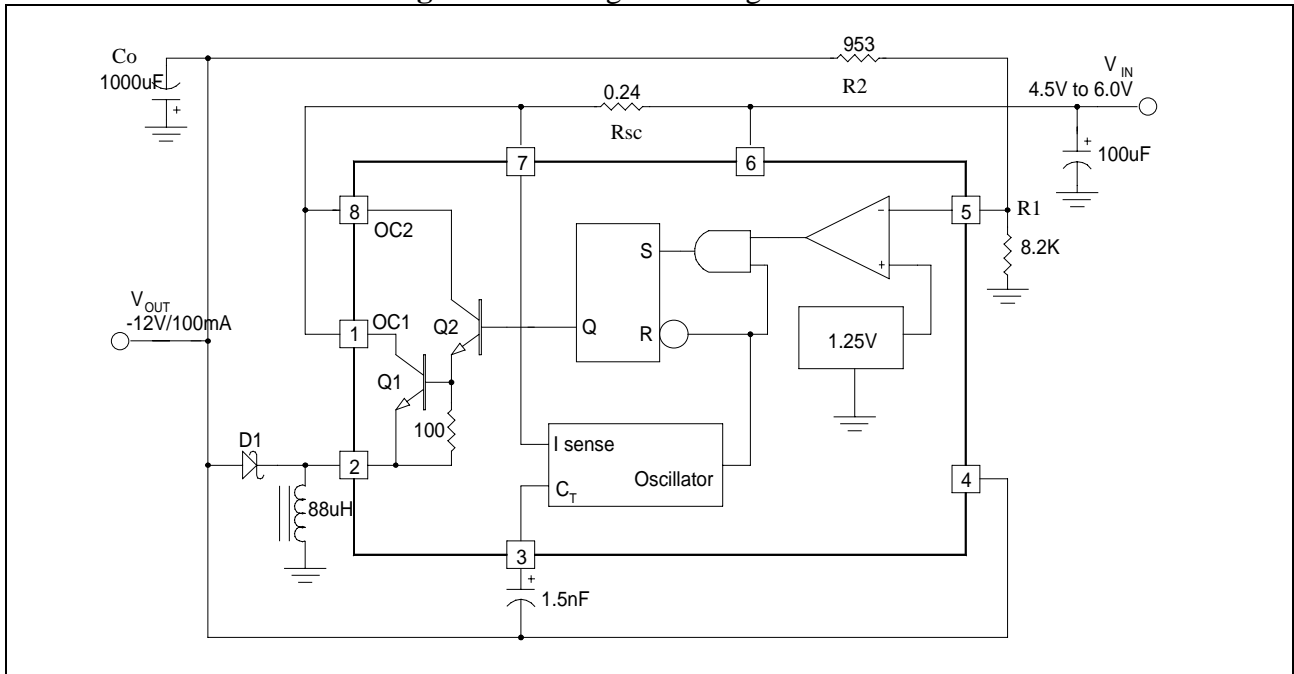

Figure 3 – Voltage Inverting Converters



Note: For step-up, step-down or voltage inverting applications requiring peak current greater than 1.5A, external boost current circuitry by NPN or PNP transistors can be used.

Typical Design Reference Table:

Calculation	Step-Down	Step-Up	Voltage-Inverting
t_{on}/t_{off}	$\frac{V_{out} + V_F}{V_{in(min)} - V_{sat} - V_{out}}$	$\frac{V_{out} + V_F - V_{in(min)}}{V_{in(min)} - V_{sat}}$	$\frac{?V_{out} + V_F}{V_{in} - V_{sat}}$
$t_{on} + t_{off}$	$\frac{1}{f}$	$\frac{1}{f}$	$\frac{1}{f}$
t_{off}	$\frac{t_{on} + t_{off}}{t_{on}/t_{off} + 1}$	$\frac{t_{on} + t_{off}}{t_{on}/t_{off} + 1}$	$\frac{t_{on} + t_{off}}{t_{on}/t_{off} + 1}$
t_{on}	$(t_{on} + t_{off}) - t_{off}$	$(t_{on} + t_{off}) - t_{off}$	$(t_{on} + t_{off}) - t_{off}$
C_T	$4.0 \times 10^{-5} t_{on}$	$4.0 \times 10^{-5} t_{on}$	$4.0 \times 10^{-5} t_{on}$
$I_{pk(switch)}$	$2I_{out(max)}$	$2I_{out(max)} (t_{on}/t_{off} + 1)$	$2I_{out(max)} (t_{on}/t_{off} + 1)$
R_{SC}	$0.3/I_{pk(switch)}$	$0.3/I_{pk(switch)}$	$0.3/I_{pk(switch)}$
$L_{(min)}$	$\left(\frac{V_{in(min)} - V_{sat} - V_{out}}{I_{pk(switch)}} \right) t_{on(max)}$	$\left(\frac{V_{in(min)} - V_{sat}}{I_{pk(switch)}} \right) t_{on(max)}$	$\left(\frac{V_{in(min)} - V_{sat}}{I_{pk(switch)}} \right) t_{on(max)}$
C_O	$\frac{I_{pk(switch)} (t_{on} + t_{off})}{8V_{ripple(pp)}}$	$9 \frac{I_{out} t_{on}}{V_{ripple(pp)}}$	$9 \frac{I_{out} t_{on}}{V_{ripple(pp)}}$

V_F : Forward Voltage drop of the output rectifier

V_{sat} : Saturation voltage of the output switch.

The following power supply characteristics must be chosen:

V_{in} - Nominal input voltage

V_{out} - Desired output voltage, $?V_{out} = 1.25(1 + R1/R2)$

I_{out} - Desired output current.

f_{min} - Minimum desired output switching frequency at the selected values of V_{in} and I_O

$V_{ripple(pp)}$ - Desired peak - to - peak output ripple voltage.

Application concerns:

To get the best regulation performance, Low ESR capacitors at V_{out} are suggested.

PACKAGE

8-Pin Plastic DIP

	INCHES			MILLIMETERS		
	MIN	TYP	MAX	MIN	TYP	MAX
A	0.355	0.365	0.400	9.02	9.27	10.16
B	0.240	0.250	0.280	6.10	6.35	7.11
C	-	-	0.210	-	-	5.33
D	-	0.018	-	-	0.46	-
F	-	0.060	-	-	1.52	-
G	-	0.100	-	-	2.54	-
H	0.050	-	0.090	1.27	-	2.29
J	0.008	-	0.015	0.20	-	0.38
K	0.115	0.130	0.150	2.92	3.30	3.81
L	0.300 BSC.			7.62 BSC.		
M	-	7°	15°	-	7°	15°

8-Pin Plastic S.O.I.C.

	INCHES			MILLIMETERS		
	MIN	TYP	MAX	MIN	TYP	MAX
A	0.183	-	0.202	4.65	-	5.13
B	0.144	-	0.163	3.66	-	4.14
C	0.068	-	0.074	1.73	-	1.88
D	0.010	-	0.020	0.25	-	0.51
F	0.015	-	0.035	0.38	-	0.89
G	0.050 BSC			1.27 BSC		
J	0.007	-	0.010	0.19	-	0.25
K	0.005	-	0.010	0.13	-	0.25
L	0.189	-	0.205	4.80	-	5.21
M	-	-	8°	-	-	8°
P	0.228	-	0.244	5.79	-	6.20



IMPORTANT NOTICE

ADDtek reserves the right to make changes to its products or to discontinue any integrated circuit product or service without notice, and advises its customers to obtain the latest version of relevant information to verify, before placing orders, that the information being relied on is current.

A few applications using integrated circuit products may involve potential risks of death, personal injury, or severe property or environmental damage. ADDtek integrated circuit products are not designed, intended, authorized, or warranted to be suitable for use in life-support applications, devices or systems or other critical applications. Use of ADDtek products in such applications is understood to be fully at the risk of the customer. In order to minimize risks associated with the customer's applications, the customer should provide adequate design and operating safeguards.

ADDtek assumes no liability to customer product design or application support. ADDtek warrants the performance of its products to the specifications applicable at the time of sale.

ADDtek Corp.
9F, No. 20, Sec. 3, Bade Rd., Taipei, Taiwan, 105
TEL: 2-25700299
FAX: 2-25700196
