

5-TAP AUTO-INSERT , SURFACE MOUNT DIPS .. AIMD, FAIDM, AMDM, FAMDM SERIES

5-TAP PART NUMBERS		OUTPUT DELAY (ns)	TAPS (ns)
14-PIN	8-PIN		
**FAIDM-7	**FAMDM-7	7 ± 1.00	1 ± 0.5
**AIMD-9	**AMDM-9	9 ± 1.00	1 ± 0.5
**FAIDM-11	**FAMDM-11	11 ± 1.00	2 ± 1.0
**AIMD-13	**AMDM-13	13 ± 2.00	2 ± 1.0
**FAIDM-15	**FAMDM-15	15 ± 1.00	3 ± 1.0
**AIMD-17	**AMDM-17	17 ± 2.00	3 ± 1.0
AIMD-25	AMDM-25	25 ± 2.00	5 ± 2.0
AIMD-30	AMDM-30	30 ± 2.00	6 ± 2.0
AIMD-35	AMDM-35	35 ± 2.00	7 ± 2.0
AIMD-40	AMDM-40	40 ± 2.00	8 ± 2.0
AIMD-45	AMDM-45	45 ± 2.25	9 ± 2.0
AIMD-50	AMDM-50	50 ± 2.50	10 ± 2.0
AIMD-60	AMDM-55	60 ± 3.00	12 ± 2.0
AIMD-70	AMDM-70	70 ± 3.50	14 ± 2.0
AIMD-75	AMDM-75	75 ± 3.75	15 ± 2.5
AIMD-80	AMDM-80	80 ± 4.00	16 ± 2.5
AIMD-90	AMDM-90	90 ± 4.50	18 ± 2.5
AIMD-100	AMDM-100	100 ± 5.00	20 ± 3.0
AIMD-110	AMDM-110	110 ± 5.50	22 ± 3.0
AIMD-120	AMDM-120	120 ± 6.00	24 ± 3.0
AIMD-125	AMDM-125	125 ± 6.25	25 ± 3.0
AIMD-130	AMDM-130	130 ± 6.50	26 ± 3.0
AIMD-140	AMDM-140	140 ± 7.00	28 ± 3.0
AIMD-150	AMDM-150	150 ± 7.50	30 ± 3.0
AIMD-160	AMDM-160	160 ± 8.00	32 ± 3.2
AIMD-170	AMDM-170	170 ± 8.50	34 ± 3.4
AIMD-175	AMDM-175	175 ± 8.75	35 ± 3.5
AIMD-180	AMDM-180	180 ± 9.00	36 ± 3.6
AIMD-190	AMDM-190	190 ± 9.50	38 ± 3.8
AIMD-200	AMDM-200	200 ± 10.00	40 ± 4.0
AIMD-220	AMDM-220	220 ± 11.00	44 ± 4.4
AIMD-225	AMDM-225	225 ± 11.25	45 ± 4.5
AIMD-240	AMDM-240	240 ± 12.00	48 ± 4.8
AIMD-250	AMDM-250	250 ± 12.50	50 ± 5.0
AIMD-260	AMDM-260	260 ± 13.00	52 ± 5.2
AIMD-270	AMDM-270	270 ± 13.50	54 ± 5.4
AIMD-275	AMDM-275	275 ± 13.75	55 ± 5.5
AIMD-300	AMDM-300	300 ± 15.00	60 ± 6.0
AIMD-350	AMDM-350	350 ± 17.50	70 ± 7.0
AIMD-375	AMDM-375	375 ± 18.75	75 ± 7.5
AIMD-400	AMDM-400	400 ± 20.00	80 ± 8.0
AIMD-450	AMDM-450	450 ± 22.50	90 ± 9.0
AIMD-500	AMDM-500	500 ± 25.00	100 ± 10

PHYSICAL DIMENSIONS All dimensions in inches (mm)
 AUTO-INSERTABLE (through hole) AIMD, FAIDM-XXX : AMDM, FAMDM-XXX

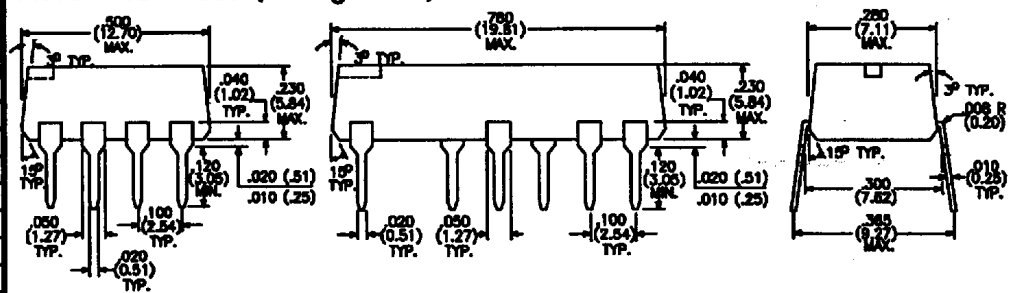

GULL WING SURFACE MOUNT AIMD, FAIDM-XXXG : AMDM, FAMDM-XXXG

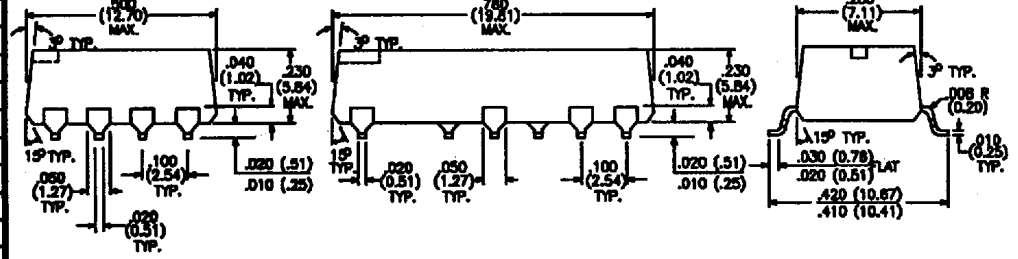

J STYLE SURFACE MOUNT AIMD, FAIDM-XXXJ : AMDM, FAMDM-XXXJ

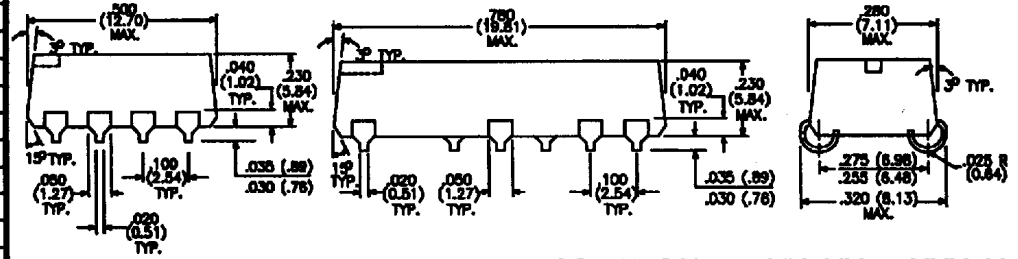

** INDICATES Delay Time measured with respect to TAP 1.

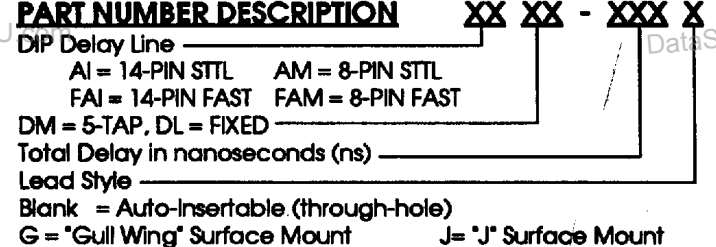

FAST TTL PART NUMBERS:
 FAIDM , FAMDM
 FAIDL , FAMDL
 See Page 10 for Pin-Outs and schematic diagrams.

5-TAP DUAL EDGE CONTROLLED DIPS DAIDM-XXX SERIES

PART NUMBER	OUTPUT DELAY (ns)	TAPS (ns)	PART NUMBER	OUTPUT DELAY (ns)	TAPS (ns)
DAIDM-25	25 ± 2.00	5 ± 2.0	DAIDM-110	110 ± 5.50	22 ± 3.0
DAIDM-30	30 ± 2.00	6 ± 2.0	DAIDM-115	115 ± 5.75	23 ± 3.0
DAIDM-35	35 ± 2.00	7 ± 2.0	DAIDM-120	120 ± 6.00	24 ± 3.0
DAIDM-40	40 ± 2.00	8 ± 2.0	DAIDM-125	125 ± 6.25	25 ± 3.0
DAIDM-45	45 ± 2.25	9 ± 2.0	DAIDM-130	130 ± 6.50	26 ± 3.0
DAIDM-50	50 ± 2.50	10 ± 2.0	DAIDM-135	135 ± 6.75	27 ± 3.0
DAIDM-55	55 ± 2.75	11 ± 2.0	DAIDM-140	140 ± 7.00	28 ± 3.0
DAIDM-60	60 ± 3.00	12 ± 2.0	DAIDM-145	145 ± 7.25	29 ± 3.0
DAIDM-65	65 ± 3.25	13 ± 2.0	DAIDM-150	150 ± 7.50	30 ± 3.0
DAIDM-70	70 ± 3.50	14 ± 2.0	DAIDM-175	175 ± 8.75	35 ± 3.5
DAIDM-75	75 ± 3.75	15 ± 2.5	DAIDM-200	200 ± 10.00	40 ± 4.0
DAIDM-80	80 ± 4.00	16 ± 2.5	DAIDM-225	225 ± 11.25	45 ± 4.5
DAIDM-85	85 ± 4.25	17 ± 2.5	DAIDM-250	250 ± 12.50	50 ± 5.0
DAIDM-90	90 ± 4.50	18 ± 2.5	DAIDM-300	300 ± 15.00	60 ± 6.0
DAIDM-95	95 ± 4.75	19 ± 2.5	DAIDM-325	325 ± 16.25	65 ± 6.5
DAIDM-100	100 ± 5.00	20 ± 3.0	DAIDM-350	350 ± 17.50	70 ± 7.0
DAIDM-105	105 ± 5.25	21 ± 3.0	DAIDM-400	400 ± 20.00	80 ± 8.0

PHYSICAL DIMENSIONS All dimensions in inches (mm)
 See above for *J* and *GULL WING* dimensions.

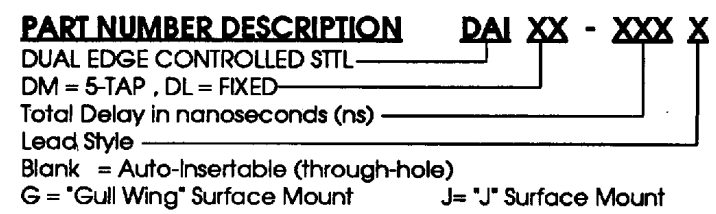
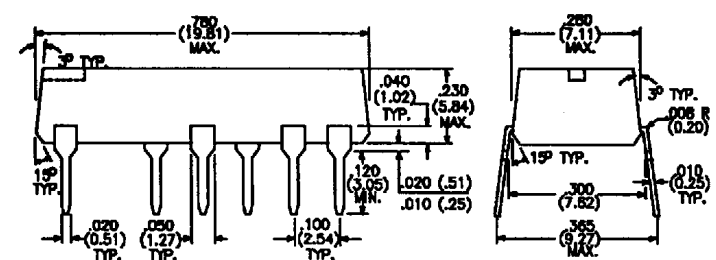

Specifications subject to change without notice



15801 Chemical Lane
 Huntington Beach, California 92649-1595
 Phone: (714) 898-0960
 FAX: (714) 896-0971

TECHNICAL APPLICATIONS MANUAL

SURFACE MOUNT APPLICATIONS

T-90-20

GENERAL OVERVIEW:

Surface mount technology has been used on hybrid circuits for many years. Its greatest recent advance has been its use on printed circuit board (PCB) assemblies. Components are attached to the PCB by soldering them directly to metalized solder pads (footprints) on its surface, rather than by insertion through plated holes drilled into the PCB. The benefits of this technology as applied to PCB's are substantial:

- Ease in automation results in higher production throughput and better yields.
- Closer spacing of components coupled with the ability to use both sides of the PCB for component mounting results in significant savings in board real estate.
- Closer spacing of components on the PCB surface significantly reduces the length of signal traces thereby reducing stray capacitance and inductance, and improving the overall performance characteristics of the circuit.
- Reduced board cost by elimination of plated through-holes, a major portion of PCB costs.
- Board rework costs and time are significantly reduced.

Many manufacturers have setup production lines that provide for both through-hole and surface mount components to be utilized on the same PCB. This has been a necessity in the past since many components have only recently been available in standard surface mount versions. It also provides for a relatively smooth and calculated transition into the technology of surface mounting.

Many OEMs have wanted to enter the surface mount arena but were reluctant, due to the large investments necessary for both equipment and personnel. To circumvent this large up-front investment, they have contracted to assembly houses which specialize in this technology. This route provides any OEM the ability to reap the many benefits of surface mount technology.

RHOMBUS SURFACE MOUNT PRODUCTS:

Through the use of our own in-house developed, and built automatic handling equipment, and inductive components designed and built specifically for use on our new product lines, Rhombus is able to offer cost effective, highly reliable product lines for through-hole as well as surface mount applications.

Rhombus has an extensive offering of surface mount delay lines and pulse transformers. All of our new style delay line products are offered in either GULL WING or J-STYLE surface mount configurations at no extra cost. Please refer to our Product Master List in the catalog index (section 1) for types and availability.

EVALUATION PROGRAM:

Rhombus has conducted extensive reliability and qualification testing both in-house and at the facilities of our major surface mount customers. The products have been designed for, and extensively used in both vapor-phase and infrared reflow systems. The evaluation/qualification program was conducted on the AIDM-XXX, AMDM-XXX, and the AITD-XXX series of products. These devices represent the span of component densities, and construction details that would be used in any and all surface mount applications including custom designs. All internal components used in our new product

TECHNICAL APPLICATIONS MANUAL

SURFACE MOUNT APPLICATIONS

lines are assembled to Alloy 42 lead frame utilizing 10Sn 90Pb solder. This reflects a solidus temperature of 268 degrees Centigrade ($268^{\circ}\text{C} = 514^{\circ}\text{F}$ Solidus) and a liquidus temperature of 298 degrees Centigrade ($290^{\circ}\text{C} = 554^{\circ}\text{F}$ Liquidus). The transfer molded package utilizes the highest Electrical Encapsulation Grade epoxy currently available and has been carefully checked for compatibility with all internal components and lead frame members. Rhombus has also incorporated all of the above qualities into our auto-insertable through-hole series.

RECOMMENDED SOLDER PADS (Delay Lines):

Rhombus developed its Gull Wing lead configuration to fit on STANDARD versions of industry accepted solder pads for SOL (small outline large .300 Wide) devices:

- Figure 26 represents the 14-pin GULL WING solder pad we recommend and is basically the equivalent of the industry standard SO-28 footprint utilizing every other pad (i.e. lead centers are .100" instead of .050").
- Figure 27 represents the 8-pin GULL WING solder pad we recommend and is basically the equivalent of the industry standard SO-16L wide footprint utilizing every other pad (i.e. lead centers are .100" instead of .050").

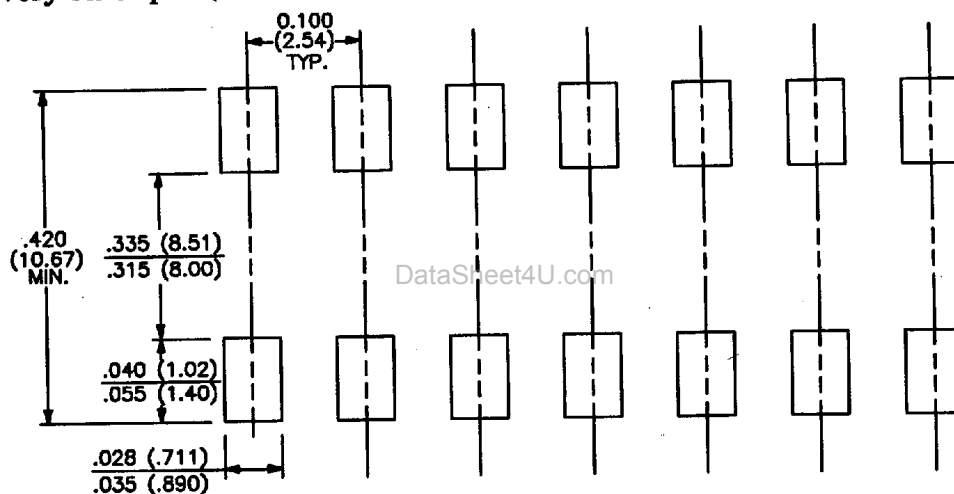

FIGURE 26: Recommended solder pad footprint, 14-pin Gull Wing configuration.

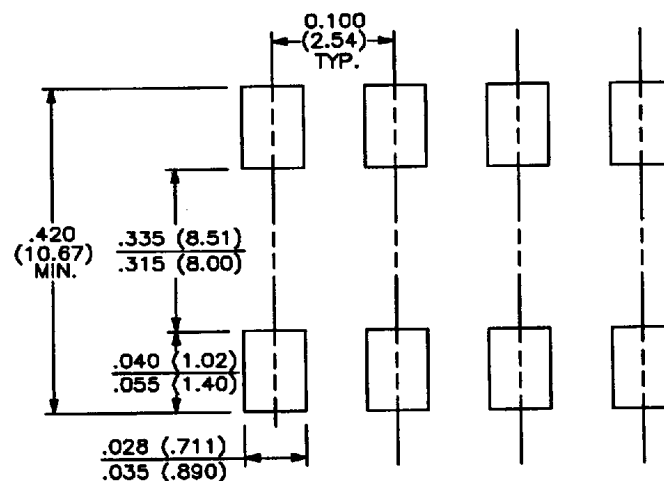

FIGURE 27: Recommended solder pad footprint, 8-pin Gull Wing configuration.

TECHNICAL APPLICATIONS MANUAL

SURFACE MOUNT APPLICATIONS

Rhombus has also developed a J-Style lead configuration for those customers that may prefer this style or simply need to save even more board space:

- Figure 28 represents the 14-pin J-STYLE solder pad we recommend.
- Figure 29 represents the 8-pin J-STYLE solder pad we recommend.

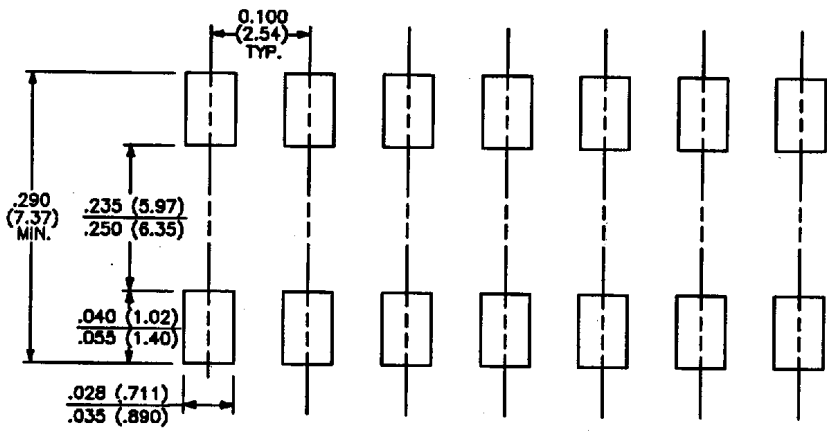

FIGURE 28: Recommended footprint, 14-pin J-Style.

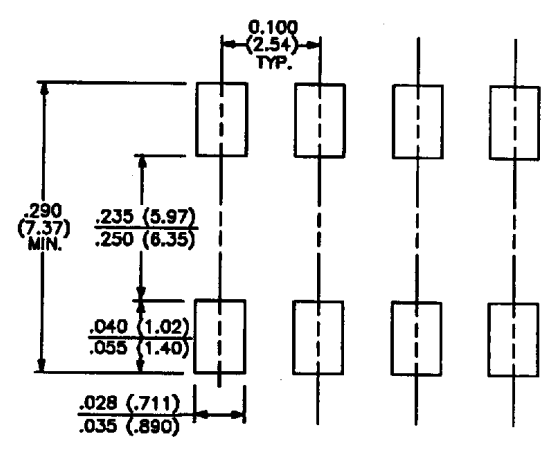

FIGURE 29: Recommended footprint, 8-pin J-Style.

REFLOW RECOMMENDATIONS:

Figure 30 represents the maximum recommended time temperature profiles that should be used with our surface mount delay line products. Careful evaluation of pulse transformers is recommended in any surface mount application due to the fact that ferrite materials are susceptible to changes when exposed to temperatures such as those required for surface mount applications.

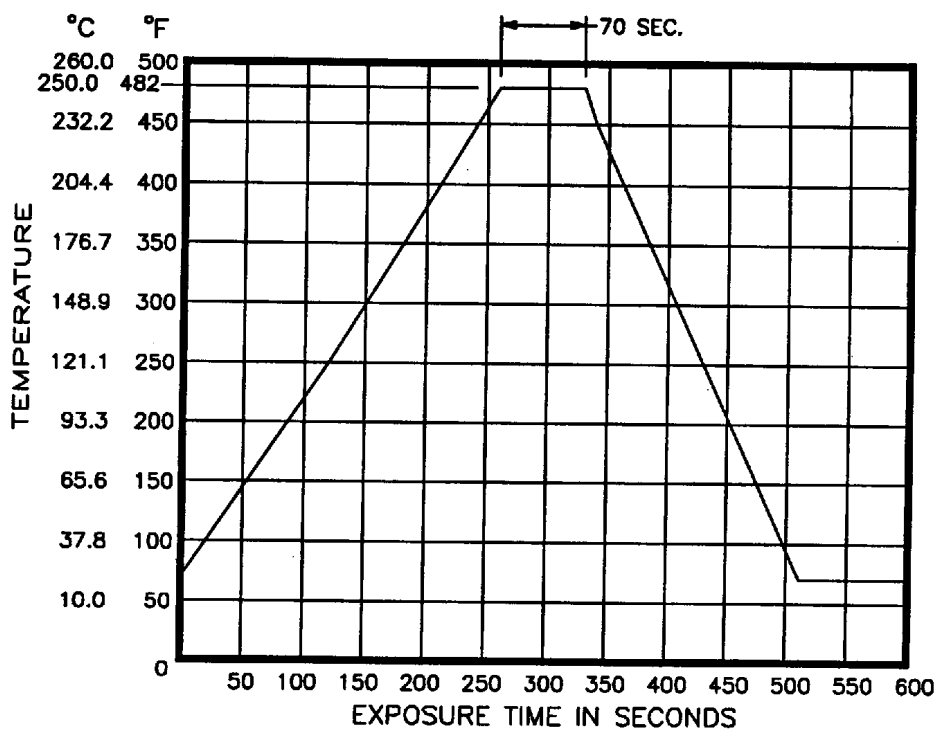

FIGURE 30: Maximum Recommended Re-Flow Profile