

■ General Description

The AME5283 is a Synchronous Rectified Step-Down Converter with internal power MOSFETs. It achieves 2A continuous output current over a wide switching frequency range with excellent load and line regulation.

Current mode operation provides fast transient response and eases of loop stabilization. The circuit protection includes cycle-by-cycle current limiting, output short circuit frequency protection and thermal shutdown. In shutdown mode, the regulator reduces the current less than 1 μ A of supply current.

This device is available in SOP-8/PP and DFN-8C package with exposed pad for low thermal resistance.

■ Features

- 2A Output Current
- External Soft Start
- Stable with Low ESR Output Ceramic Capacitors
- Up to 95% Efficiency
- Less than 1 μ A Shutdown Current
- Wide Switching Frequency Range from 300KHz~2MHz
- Thermal Shutdown
- Cycle by Cycle Over Current Protection
- Output Adjustable from 0.8V to V_{IN}
- Short Circuit Protection
- Available in SOP-8, DFN-8C Package
- RoHS Compliant and Halogen Free

■ Applications

- TV
- Distributed Power Systems
- Pre-Regulator for Linear Regulators

■ Typical Application

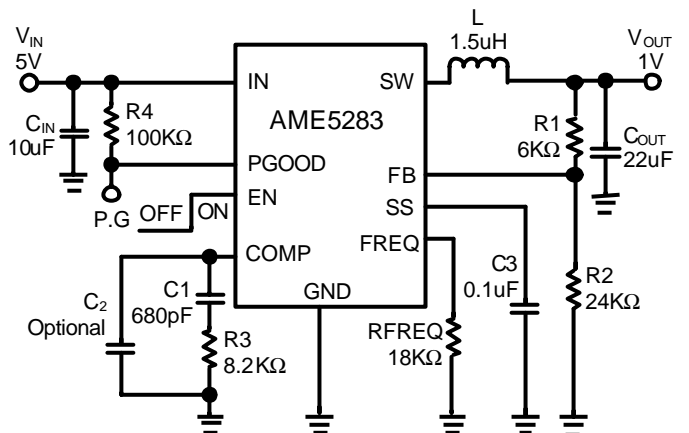
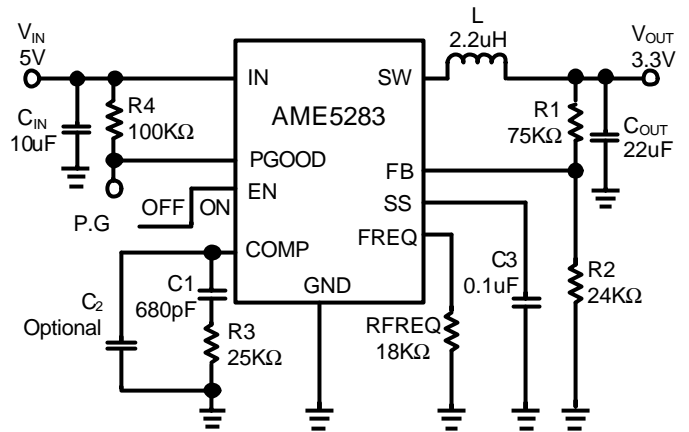

AME5283

Functional Block Diagram

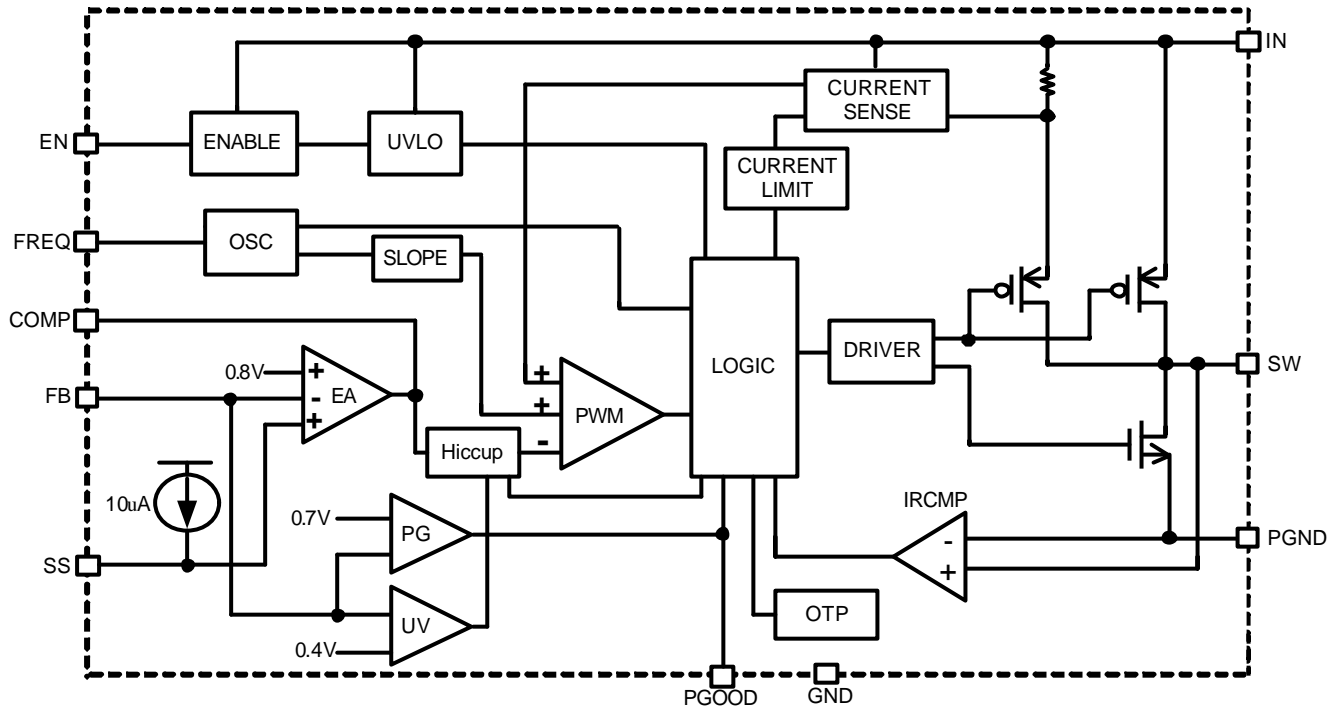

Pin Configuration

SOP-8/PP
Top View

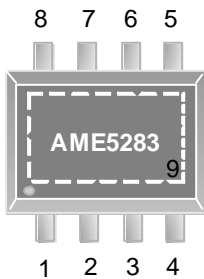

AME5283-AZAADJ

1. COMP
2. SS
3. EN
4. IN
5. SW
6. FREQ
7. FB
8. PG
9. GND (Exposed Pad)

* Die Attach:
Conductive Epoxy

DFN-8C
(3mmx3mmx0.75mm)
Top View

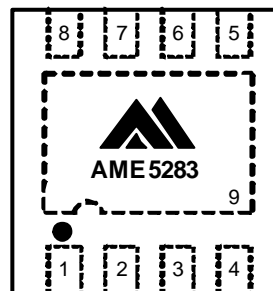

AME5283-AVAADJ

1. COMP
2. SS
3. EN
4. IN
5. SW
6. FREQ
7. FB
8. PG
9. GND (Exposed Pad)

* Die Attach:
Conductive Epoxy

Note. Connect exposed pad (heat sink on the back) to GND.

AME5283
■ Pin Description

Pin No.	Pin Name	Pin Description
1	COMP	Compensation Node. COMP is used to compensate the regulation control loop. Connect a series RC network from COMP to GND to compensate the regulation control loop. In some cases, an additional capacitor from COMP to GND is required.
2	SS	Soft-Start function. Connect a capacitor from SS to GND to set the soft-start period.
3	EN	Enable. Pull EN below 0.6V to shut down the regulator.
4	IN	Power Input. IN supplies the power to the IC, as well as the step-down converter switches. Bypass IN to GND with a suitable large capacitor to eliminate noise on the input to the IC.
5	SW	Power Switching Output. SW is the switching node that supplies power to the output. Connect the output LC filter from SW to the output load.
6	FREQ	Frequency Adjust Pin. Add a resistor from this pin to ground determines the switching frequency.
7	FB	Feedback Input. FB senses the output voltage to regulate that voltage. Drive FB with a resistive voltage divider from the output voltage. The feedback reference voltage is 0.8V.
8	PG	Power-Good output. This open-drain output is low when output is out of regulation.
9	GND	Ground. Connect the exposed pad to GND.

AME5283

■ Ordering Information

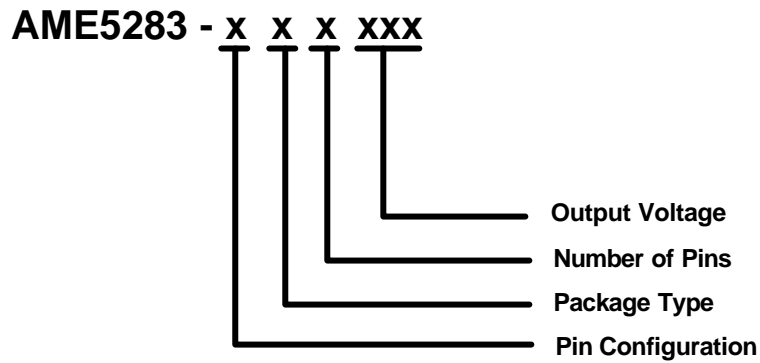

Pin Configuration	Package Type	Number of Pins	Output Voltage
<p>A (SOP-8/PP)</p> <p>1. COMP 2. SS 3. EN 4. IN 5. SW 6. FREQ 7. FB 8. PG 9. GND</p>	<p>V: DFN Z: SOP/PP</p>	<p>A: 8</p>	<p>ADJ: Adjustable</p>
<p>A (DFN-8C)</p> <p>1. COMP 2. SS 3. EN 4. IN 5. SW 6. FREQ 7. FB 8. PG 9. GND</p>			

AME5283
■ Absolute Maximum Ratings

Parameter	Symbol	Maximum	Unit
Supply Voltage	V_{IN}	-0.3V to +6V	V
Switch Voltage	V_{SW}	-1.5V to $V_{IN}+0.7V$	V
EN, FB, COMP, FREQ to GND		-0.3V to $V_{IN}+0.3V$	V
ESD Classification	HBM	2	kV
	MM	200	V

■ Recommended Operating Conditions

Parameter	Symbol	Rating	Unit
Ambient Temperature Range	T_A	-40 to +85	°C
Junction Temperature Range	T_J	-40 to +125	
Storage Temperature Range	T_{STG}	-65 to +150	

■ Thermal Information

Parameter	Package	Die Attach	Symbol	Maximum	Unit	
Thermal Resistance* (Junction to Case)	SOP-8/PP	Conductive Epoxy	θ_{JC}	15	°C / W	
	DFN-8C			8.2		
Thermal Resistance (Junction to Ambient)	SOP-8/PP		θ_{JA}	75		
	DFN-8C			70		
Internal Power Dissipation	SOP-8/PP		P_D	1.333		mW
	DFN-8C			1.429		
Maximum Junction Temperature				150	°C	
Lead Temperature (Soldering 10sec)**				260	°C	

* Measure θ_{JC} on backside center of molding compound if IC has no tab.

** MIL-STD-202G 210F

AME5283
■ Electrical Specifications
 $V_{IN}=5V$, $T_A=25^{\circ}C$, unless otherwise noted.

Parameter	Symbol	Test Condition	Min	Typ	Max	Units
Input Voltage Range	V_{IN}		2.5		5.5	V
Input UVLO	V_{UVLO}			2.3		V
Quiescent Current	I_Q	$V_{EN}=5V$, $V_{FB}=0.7V$ (No Switching)		600		μA
Shutdown Current	I_{SHDN}	$V_{EN}=0V$			1	μA
Feedback Voltage	V_{FB}		0.784	0.8	0.816	V
Feedback Current	I_{FB}		-50		50	nA
Load Regulation	REG_{LOAD}	$0A < I_{OUT} < 2A$		0.25		%/A
Line Regulation	REG_{LINE}	$2.7V < V_{IN} < 5.5V$		0.25		%/V
EN Voltage High	V_{EN}		1.4			V
EN Voltage Low					0.4	V
EN Leakage Current	I_{ENLK}	$V_{EN}=3V$		0.1	1	μA
Switching Frequency	F_{SW}	$R_{FREQ}=NC$	240	300	360	KHz
		$R_{FREQ}=120K\Omega$	480	600	720	KHz
		$R_{FREQ}=47K\Omega$	0.8	1	1.2	MHz
		$R_{FREQ}=18K\Omega$	1.6	2		MHz
High-side Switch Current Limit			3.3	3.7		A
Error Amp Transconductance	G_{EA}			400		$\mu A/V$
Switch Leakage Current	I_{SWLK}	$V_{SW}=0V$, $V_{EN}=0V$		0.1	20	μA
High-side Switch On Resistance	$R_{DSON,HI}$			130		$m\Omega$
Low-side Switch On Resistance	$R_{DSON,LO}$			90		$m\Omega$
Thermal Shutdown Protection	OTP	Rising		160		$^{\circ}C$
	OTH	Hysteresis		20		$^{\circ}C$

■ Detailed Description

Normal Operation

The AME5283 uses a user adjustable frequency, current mode step-down architecture with internal MOSFET switch. During normal operation, the internal high-side (PMOS) switch is turned on each cycle when the oscillator sets the SR latch, and turned off when the comparator resets the SR latch. The peak inductor current at which the comparator resets the SR latch is controlled by the output of error amplifier EA. While the high-side switch is off, the low-side switch turns on until either the inductor current starts to reverse or the beginning of the next switching cycle.

Dropout Operation

The output voltage is dropped from the input supply for the voltage which across the high-side switch. As the input supply voltage decreases to a value approaching the output voltage, the duty cycle increases toward the maximum on-time. Further reduction of the supply voltage forces the high-side switch to remain on for more than one cycle until it reaches 100% duty cycle.

Power Good Output

The AME5283 power good output is an open-drain output and requires a pull up resistor. When the output voltage is 12.5% above or 12.5% below its set voltage, PGOOD will be pulled low. It is held low until the output voltage returns to within the allowed tolerances once more. During soft-start, PGOOD is actively held low and is only allowed to transition high when soft-start is over and the output voltage reaches 87.5% of its set voltage.

Soft-Start

The AME5283 contains an external soft-start clamp that gradually raises the output voltage. The soft-start timing is programmed by the external capacitor between SS pin and GND. The chip provides an internal charge current for the external capacitor. If 10nF capacitor is used to set the soft-start, the period will be 800uS(typ.).

Hiccup Mode

During hiccup mode, the AME5283 disables the high-side MOSFET and begins a cool down period of 8000uS. At the conclusion of this cool down period, the regulator performs an external 800uS identical to the soft start at turn-on. (If 10nF capacitor is used to set the soft-start)

Under Voltage Protection

Under Voltage Protection will activate once the feedback voltage falls below 0.4V, the operating frequency is switched to 1/10 of normal switching frequency and after four-times hiccup mode counted, the internal high-side power switch will be turned off, and latched, Unless Restart the power supply.

Over Current Protection

The AME5283 cycle-by-cycle limits the peak inductor current to protect embedded switch from damage. Hence the maximum output current (the average of inductor current) is also limited. In case the load increases, the inductor current is also increase. Whenever the current limit level is reached, the output voltage can not be regulated and starting to drop.

Over Temperature Protection

The in most applications the AME5283 does not dissipate much heat due to high efficiency. But, in applications where the AME5283 is running at high ambient temperature with low supply voltage and high duty cycles, such as in dropout, the heat dissipated may exceed the maximum junction temperature of the part. If the junction temperature reaches approximately 160°C, the internal high-side power switch will be turned off and the SW switch will become high impedance.

Inductor Selection

For most applications, the value of the inductor will fall in the range of 2.2μH to 4.7μH. Its value is chosen based on the desired ripple current. Large value inductors lower ripple current and small value inductors result in higher ripple currents. Higher V_{IN} or V_{OUT} also increase the ripple current ΔI_L :

$$\Delta I_L = \frac{1}{f \times L} V_{OUT} \left(1 - \frac{V_{OUT}}{V_{IN}} \right)$$

A reasonable inductor current ripple is usually set as 1/3 to 1/5 of maximum out current. The DC current rating of the inductor should be at least equal to the maximum load current plus half the ripple current to prevent core saturation. For better efficiency, choose a low DCR inductor.

Capacitor Selection

In continuous mode, the source current of the top MOSFET is a square wave of duty cycle V_{OUT}/V_{IN} . To prevent large voltage transients, a low ESR input capacitor sized for maximum RMS current must be used. The maximum RMS capacitor current is given by:

$$C_{IN} \text{ requires } I_{RMS} \cong I_{OMAX} \frac{\sqrt{V_{OUT}(V_{IN} - V_{OUT})}}{V_{IN}}$$

This formula has a maximum at $V_{IN}=2V_{OUT}$, where $I_{RMS}=I_{OUT}/2$. For simplification, use an input capacitor with a RMS current rating greater than half of the maximum load current.

The selection of C_{OUT} is driven by the required effective series resistance (ESR). Typically, once the ESR requirement for C_{OUT} has been met, the RMS current rating generally far exceeds the $I_{RIPPLE(P-P)}$ requirement. The output ripple V_{OUT} is determined by:

$$\Delta V_{OUT} \cong \Delta I_L \left(ESR + \frac{1}{8fC_{OUT}} \right)$$

For a fixed output voltage, the output ripple is highest at maximum input voltage since ΔI_L increases with input voltage.

When choosing the input and output ceramic capacitors, choose the X5R or X7R dielectric formulations. These dielectrics have the best temperature and voltage characteristics of all the ceramics for given value and size

Output Voltage Programming

The AME5283 output voltage of the AME5283 is set by a resistive divider according to the following formula:

$$V_{OUT} = 0.8 \times \left[1 + \frac{R1}{R2} \right] \text{ Volt.}$$

Some standard value of R1, R2 for most commonly used output voltage values are listed in Table 1.

V _{out} (V)	R1(KW)	R2(KW)
1.1	7.5	20
1.2	10	20
1.5	17.4	20
1.8	30	24
2.5	51	24
3.3	75	24

Loop Compensation

The AME5283 employs peak current mode control for easy use and fast transient response. Peak current mode control eliminates the double pole effect of the output LC filter. It greatly simplifies the compensation loop design.

With peak current mode control, the buck power stage can be simplified to be a one-pole and one-zero system in frequency domain. The pole can be calculated by:

$$f_{p1} = \frac{1}{2p \times C_{OUT} \times R_L}$$

The zero is a ESR zero due to output capacitor and its ESR. It can be calculated by:

$$f_{z1} = \frac{1}{2p \times C_{OUT} \times ESR_{COUT}}$$

Where C_{OUT} is the output capacitor, R_L is load resistance;

ESR_{COUT} is the equivalent series resistance of output capacitor.

The compensation design is to shape the converter close loop transfer function to get desired gain and phase. For most cases, a series capacitor and resistor network connected to the COMP pin sets the pole-zero and is adequate for a stable high-bandwidth control loop.

In the AME5283, FB pin and COMP pin are the inverting input and the output of internal transconductance error amplifier (EA). A series RC and CC compensation network connected to COMP pin provides one pole and one zero: for $R_C \ll A_{EA}/G_{EA}$

$$f_{p2} = \frac{1}{2p \times C_C \times \left(R_C + \frac{A_{EA}}{G_{EA}} \right)} \approx \frac{G_{EA}}{2p \times C_C \times A_{EA}}$$

$$f_{z2} = \frac{1}{2p \times C_C \times R_C}$$

Where G_{EA} is the error amplifier transconductance

A_{EA} is the error amplifier voltage gain

R_C is the compensation resistor

C_C is the compensation capacitor

The desired crossover frequency f_c of the system is defined to be the frequency where the control loop has unity gain. It is also called the bandwidth of the converter. In general, a higher bandwidth means faster response to load transient. However, the bandwidth should not be too high because of system stability concern. When designing the compensation loop, converter stability under all line and load condition must be considered. Usually, it is recommended to set the bandwidth to be less than 1/10 of switching frequency. Using selected crossover frequency, f_c , to calculate R_C :

$$R_C = f_c \times \frac{V_{OUT}}{V_{FB}} \times \frac{2p \times C_{OUT}}{G_{EA} \times G_{CS}}$$

Where G_{CS} is the current sense circuit transconductance. The compensation capacitor C_C and resistor R_C together make zero. This zero is put somewhere close to the pole f_{p1} of selected frequency. C_C is selected by:

$$C_C = \frac{C_{OUT} \times R_L}{R_C}$$

Checking Transient Response

The regulator loop response can be checked by looking at the load transient response. Switching regulators take several cycles to respond to a step in load current. When a load step occurs, V_{OUT} immediately shifts by an amount equal to $(\Delta I_{LOAD} \times ESR)$, where ESR is the effective series resistance of C_{OUT} . ΔI_{LOAD} also begins to charge or discharge C_{OUT} , which generates a feedback error signal.

The regulator loop then acts to return V_{OUT} to its steady state value. During this recovery time V_{OUT} can be monitored for overshoot or ringing that would indicate a stability problem.

AME5283**Efficiency Considerations**

Although all dissipative elements in the circuit produce losses, one major source usually account for most of the losses in AME5283 circuits: I_2R losses. The I_2R loss dominates the efficiency loss at medium to high load currents.

The I_2R losses are calculated from the resistances of the internal switches, R_{SW} , and external inductor R_L . In continuous mode, the average output current flowing through inductor L is "chopped" between the main switch and the synchronous switch. Thus the series resistance looking into the SW pin is a function of both top and bottom MOSFET $R_{DS(ON)}$ and the duty cycle (D) as follows:

$$R_{SW} = (R_{DS(ON)TOP})(D) + (R_{DS(ON)BOTTOM})(1-D)$$

The $R_{DS(ON)}$ for both the top and bottom MOSFETs can be obtained from Electrical Characteristics table. Thus, to obtain I_2R losses, simply add R_{SW} to R_L and multiply the result by the square of the average output current.

Other losses including C_{IN} and C_{OUT} ESR dissipative losses and inductor core losses generally account for less than 2% total additional loss.

Thermal Considerations

In most application the AME5283 does not dissipate much heat due to its high efficiency. But, in applications where the AME5283 is running at high ambient temperature with low supply voltage and high duty cycles, such as in dropout, the heat dissipated may exceed the maximum junction temperature of the part. If the junction temperature reaches approximately 160°C, both power switches will be turned off and the SW switch will become high impedance.

AME5283

■ Typical Operating Circuit

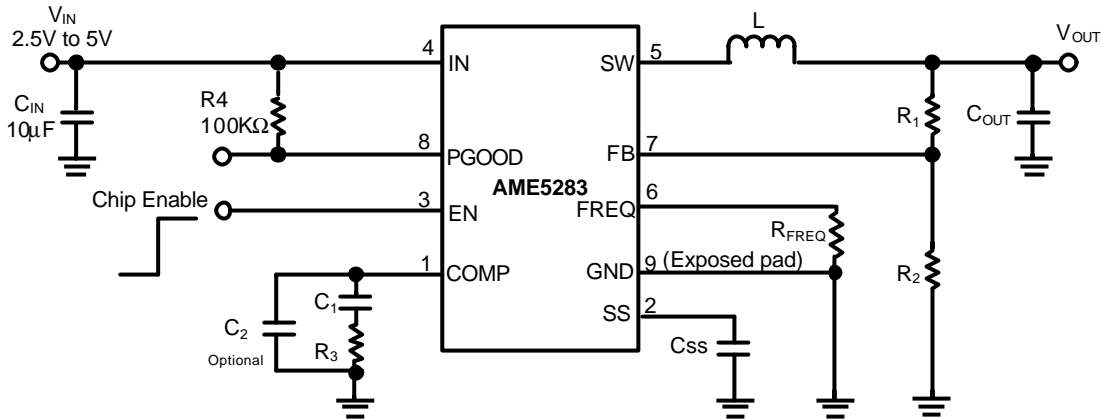

$V_{OUT}(V)$	$C_{IN}(\mu F)$	$R1(K\Omega)$	$R2(K\Omega)$	$R3(K\Omega)$	$C1(pF)$	$L(\mu H)$	$C_{OUT}(\mu F)$
3.3	10	75	24	25	680	2.2	22
2.5	10	51	24	20	680	2.2	22
1.8	10	30	24	15	680	1.5	22
1.5	10	21	24	13	680	1.5	22
1.2	10	12	24	11	680	1.5	22
1	10	6	24	8.2	680	1.5	22

Table 1. Recommended Components Selectin for fsw = 2MHz

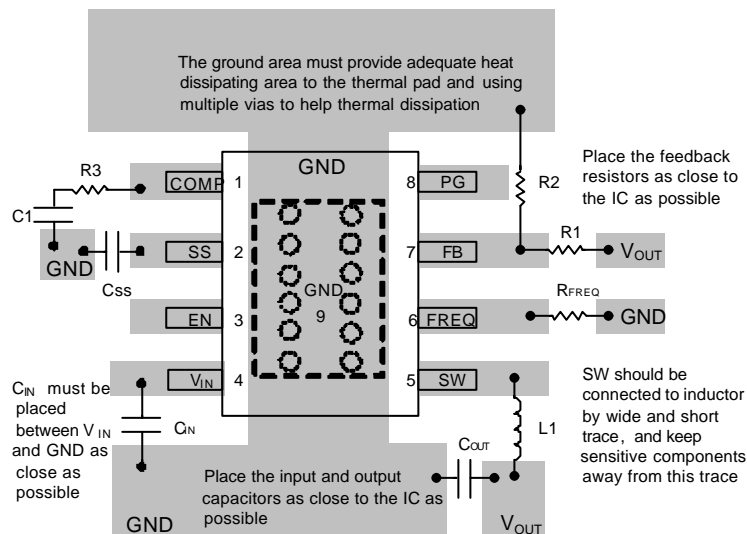
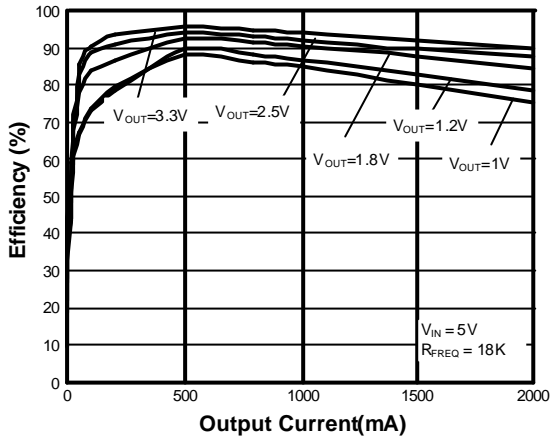
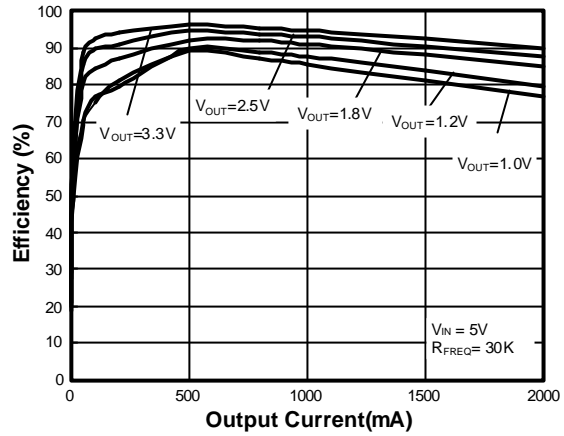
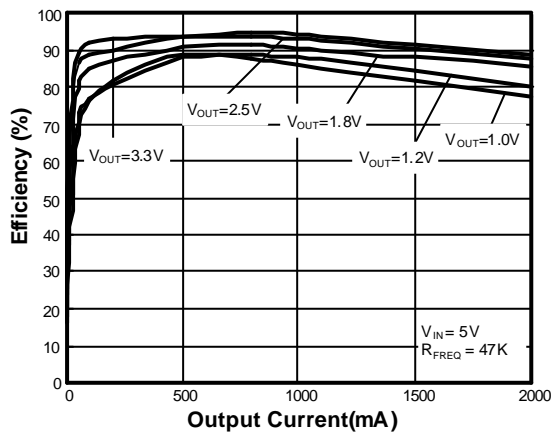
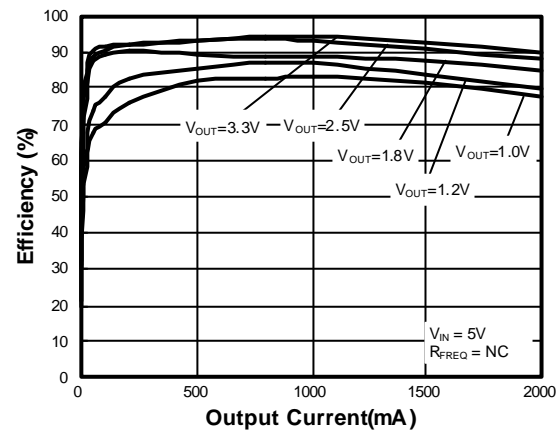
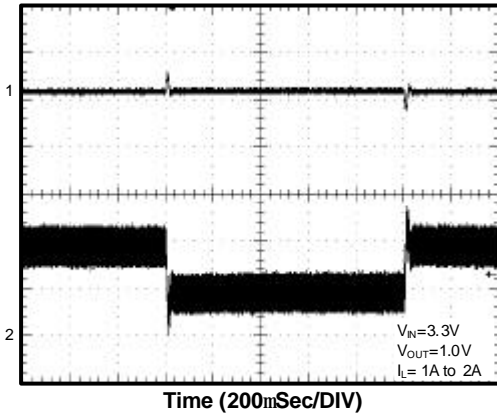
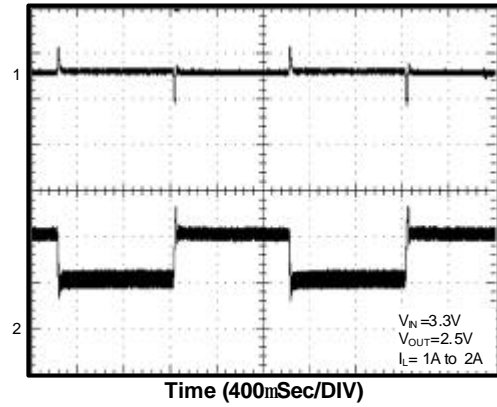

Figure 3. AME5283 Regulators Layout Diagram

■ Characterization Curve
Efficiency vs. Output Current

Efficiency vs. Output Current

Efficiency vs. Output Current

Efficiency vs. Output Current

■ Characterization Curve (Contd.)
Load Step

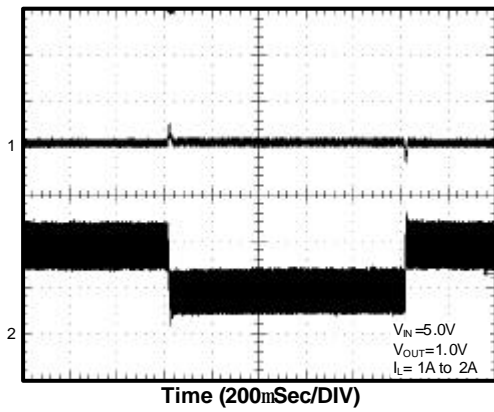
- 1) $V_{OUT}= 200mV/div$
- 2) $I_L= 1A/div$

Load Step

- 1) $V_{OUT}= 200mV/div$
- 2) $I_L= 1A/div$

Load Step

- 1) $V_{OUT}= 100mV/div$
- 2) $I_L= 1A/div$

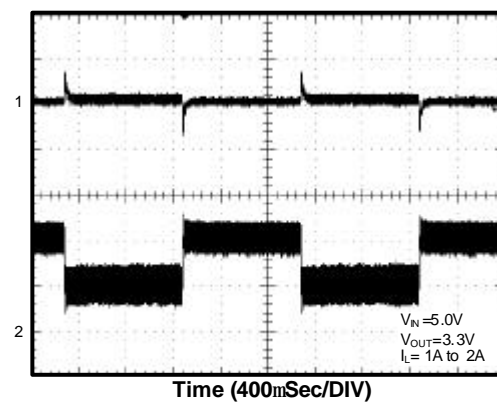
Load Step

- 1) $V_{OUT}= 100mV/div$
- 2) $I_L= 1A/div$

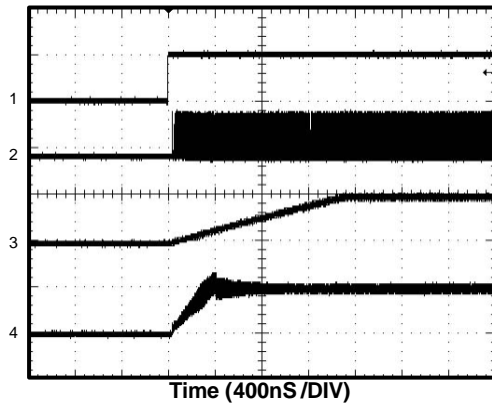
■ Characterization Curve (Contd.)
Power ON from EN

- 1) EN= 5V/div
- 2) V_{SW} = 5V/div
- 3) V_{OUT} = 1V/div
- 4) I_L = 1A/div

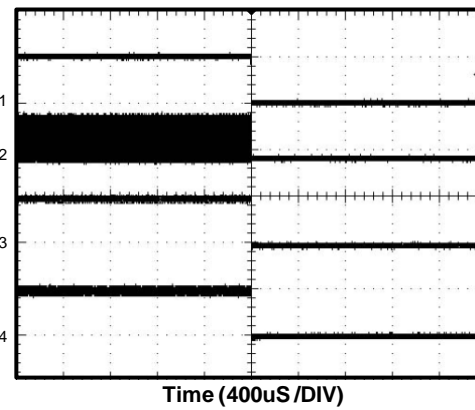
Power off from EN

- 1) EN= 5V/div
- 2) V_{SW} = 5V/div
- 3) V_{OUT} = 1V/div
- 4) I_L = 1A/div

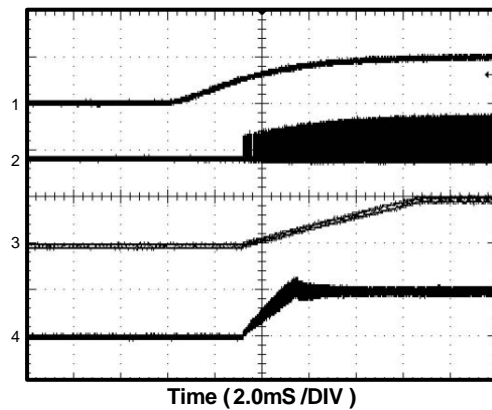
Power ON from V_{IN}

- 1) V_{IN} = 5V/div
- 2) V_{SW} = 5V/div
- 3) V_{OUT} = 1V/div
- 4) I_L = 1A/div

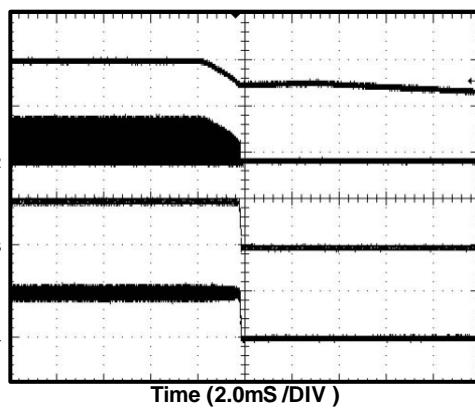
Power Off from V_{IN}

- 1) V_{IN} = 5V/div
- 2) V_{SW} = 5V/div
- 3) V_{OUT} = 1V/div
- 4) I_L = 1A/div

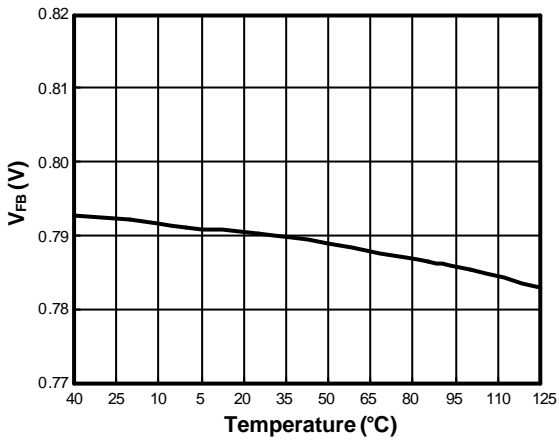
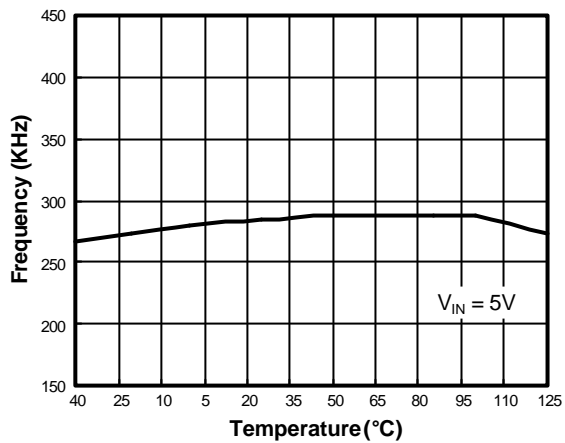
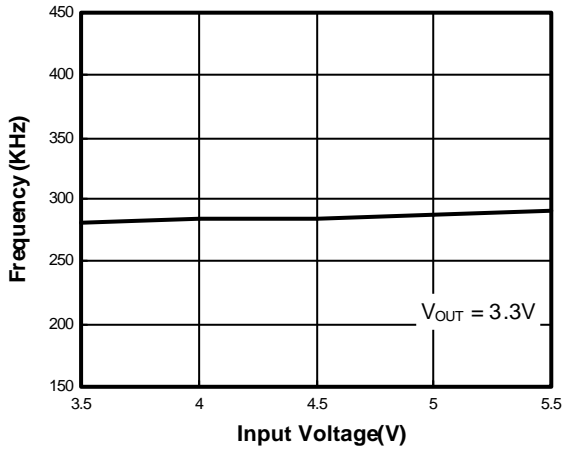
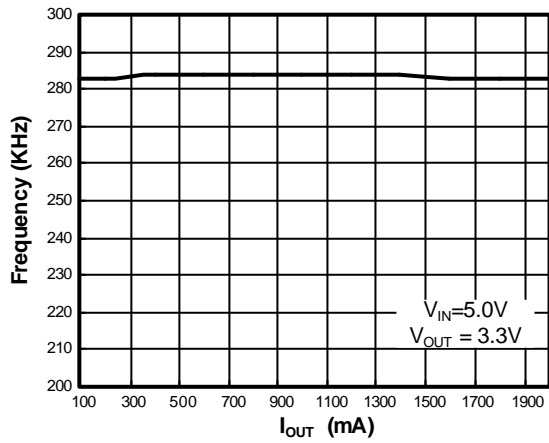
■ Characterization Curve (Contd.)
 V_{FB} vs. Temperature

Frequency vs. Temperature

Frequency vs. Supply Voltage

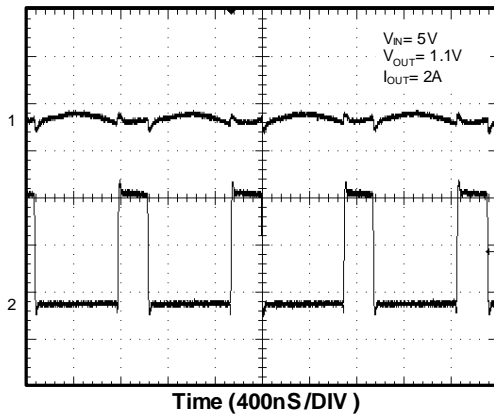
Frequency vs. Output Current

■ Characterization Curve (Contd.)

Steady State Test



- 1) $V_{OUT} = 10mV/div$
- 2) $V_{SW} = 2V/div$

Steady State Test

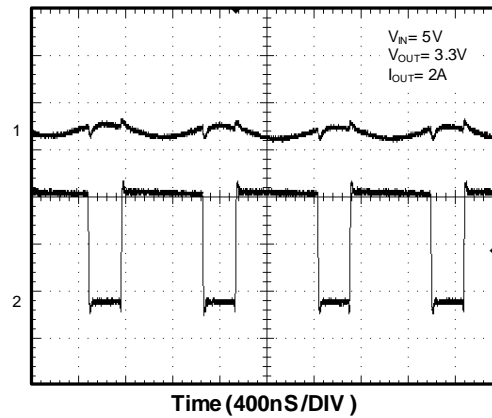

- 1) $V_{OUT} = 10mV/div$
- 2) $V_{SW} = 2V/div$

Power Good

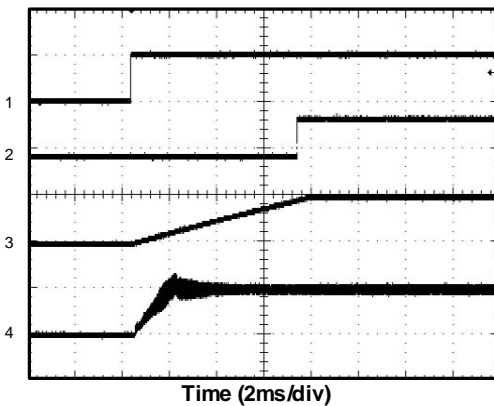

- 1) $EN = 5V/div$
- 2) $PG = 5V/div$
- 3) $V_{OUT} = 1V/div$
- 4) $I_L = 2A/div$

Short Circuit Test

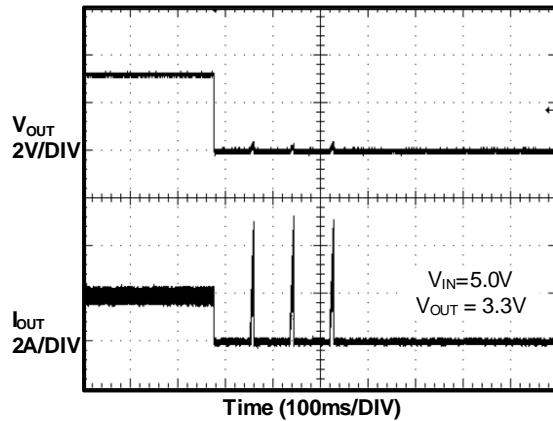

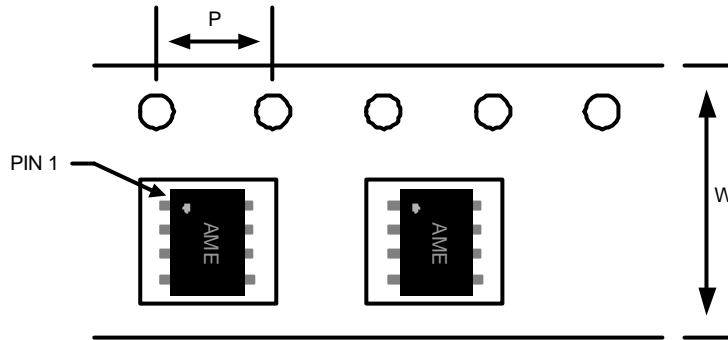
AME5283
■ Tape and Reel Dimension
SOP-8/PP

Carrier Tape, Number of Components Per Reel and Reel Size

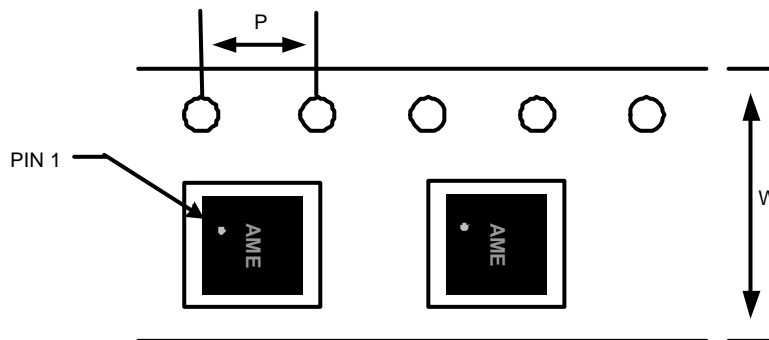
Package	Carrier Width (W)	Pitch (P)	Part Per Full Reel	Reel Size
SOP-8/PP	12.0±0.1 mm	4.0±0.1 mm	2500pcs	330±1 mm

**DFN-8C
(3mmx3mmx0.75mm)**

Carrier Tape, Number of Components Per Reel and Reel Size

Package	Carrier Width (W)	Pitch (P)	Part Per Full Reel	Reel Size
DFN-8C (3x3x0.75mm)	12.0±0.1 mm	4.0±0.1 mm	3000pcs	330±1 mm

AME5283

■ Package Dimension

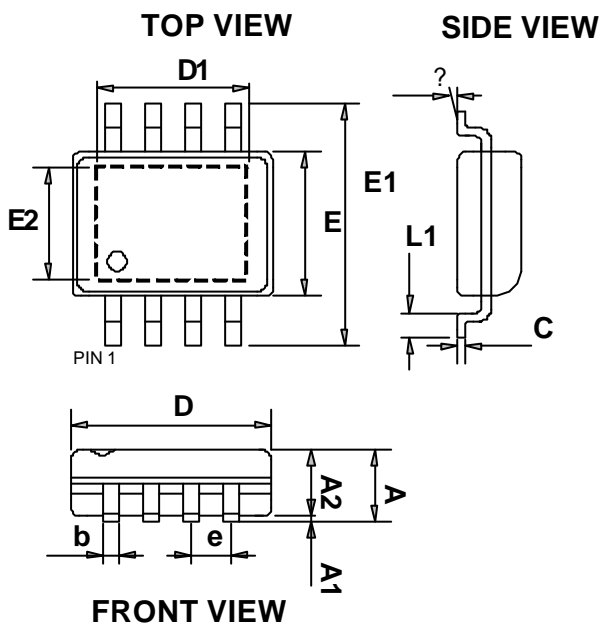
SOP-8/PP



SYMBOLS	MILLIMETERS		INCHES	
	MIN	MAX	MIN	MAX
A	1.350	1.750	0.053	0.069
A1	0.000	0.150	0.000	0.006
A2	1.350	1.600	0.053	0.063
C	0.100	0.250	0.004	0.010
E	3.750	4.150	0.148	0.163
E1	5.700	6.300	0.224	0.248
L1	0.300	1.270	0.012	0.050
b	0.310	0.510	0.012	0.020
D	4.720	5.120	0.186	0.202
e	1.270 BSC		0.050 BSC	
q	0°	8°	0°	8°
E2	2.150	2.513	0.085	0.099
D1	2.150	3.402	0.085	0.134

AME5283
■ Package Dimension (Contd.)

DFN-8C
(3mmx3mmx0.75mm)

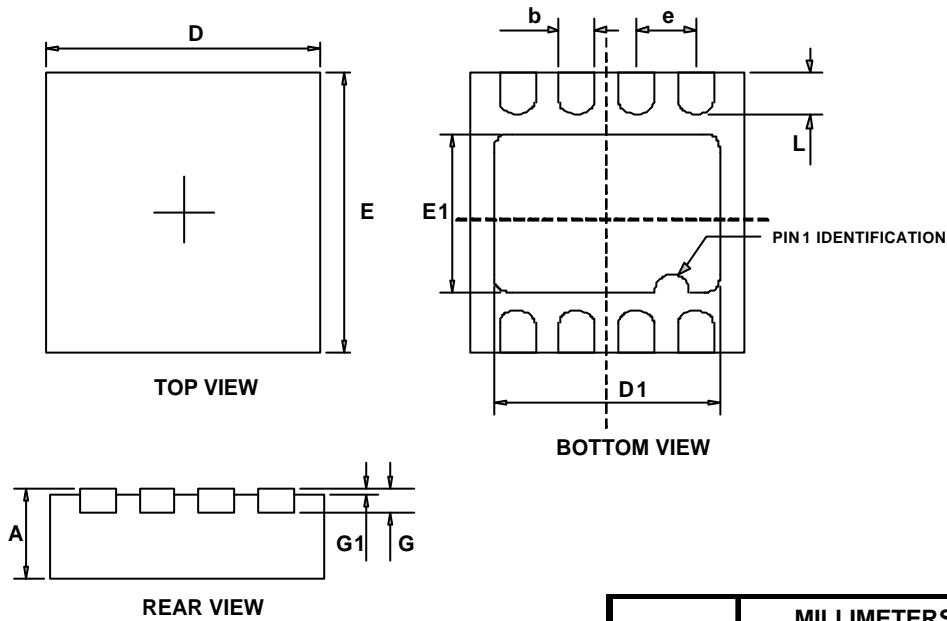

SYMBOLS	MILLIMETERS		INCHES	
	MIN	MAX	MIN	MAX
A	0.700	0.800	0.028	0.031
D	2.900	3.100	0.114	0.122
E	2.900	3.100	0.114	0.122
e	0.600	0.700	0.024	0.028
D1	2.200	2.400	0.087	0.094
E1	1.400	1.600	0.055	0.063
b	0.180	0.320	0.007	0.013
L	0.375	0.575	0.015	0.023
G	0.153	0.253	0.006	0.010
G1	0.000	0.050	0.000	0.002



www.ame.com.tw
E-Mail: sales@ame.com.tw

Life Support Policy:

These products of AME, Inc. are not authorized for use as critical components in life-support devices or systems, without the express written approval of the president of AME, Inc.

AME, Inc. reserves the right to make changes in the circuitry and specifications of its devices and advises its customers to obtain the latest version of relevant information.

© AME, Inc. , December 2012

Document: TU003-DS5283-A.03

Corporate Headquarter
AME, Inc.

8F, 12 WenHu St., Nei-Hu

Taipei 114, Taiwan .

Tel: 886 2 2627-8687

Fax: 886 2 2659-2989