

## ■ General Description

The AME8806/8809/8842 family of positive, linear regulators feature low quiescent current (30 $\mu$ A typ.) with low dropout voltage, making them ideal for battery applications. The space-saving SOP-8 package is attractive for "Pocket" and "Hand Held" applications.

These rugged devices have both Thermal Shutdown, and Current Fold-back to prevent device failure under the "Worst" of operating conditions.

In applications requiring a low noise, regulated supply, place a 1000 pF capacitor between Bypass and ground.

The AME8806/8809/8842 is stable with an output capacitance of 2.2 $\mu$ F or greater.

## ■ Features

- Very Low Dropout Voltage
- Guaranteed 600mA Output
- Accurate to within 1.5%
- 30 $\mu$ A Quiescent Current
- Over-Temperature Shutdown
- Current Limiting
- Short Circuit Current Fold-back
- Noise Reduction Bypass Capacitor
- Power-Saving Shutdown Mode
- Space-Saving SOP-8 Package
- Factory Pre-set Output Voltages
- Low Temperature Coefficient
- All AME's Lead Free Products Meet RoHS Standards

## ■ Applications

- Instrumentation
- Portable Electronics
- Wireless Devices
- Cordless Phones
- PC Peripherals
- Battery Powered Widgets
- Electronic Scales

## ■ Functional Block Diagram

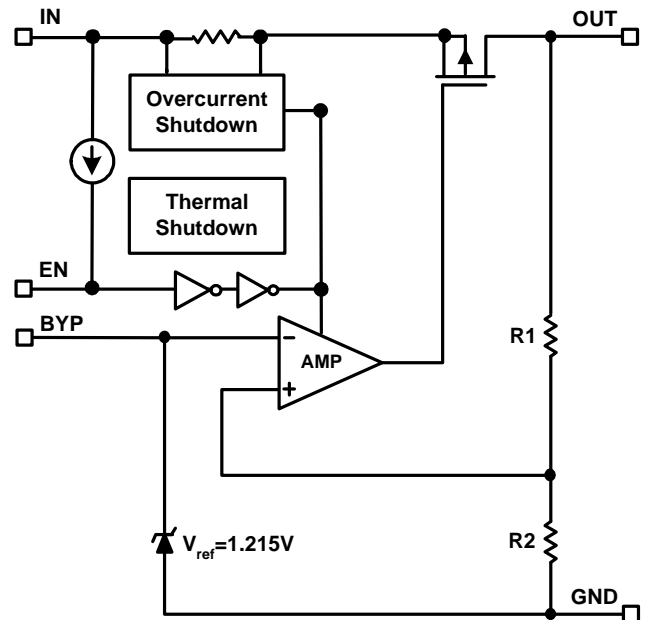

## ■ Typical Application

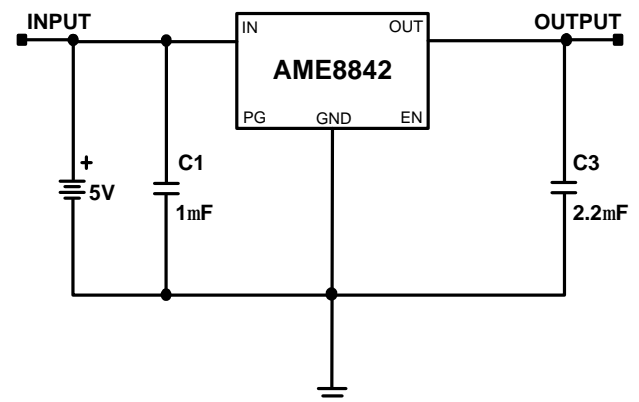
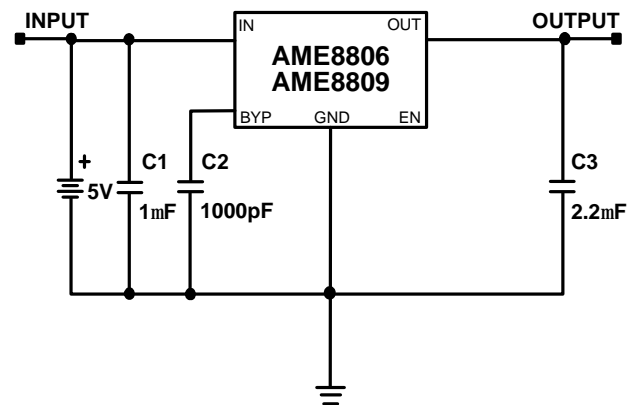

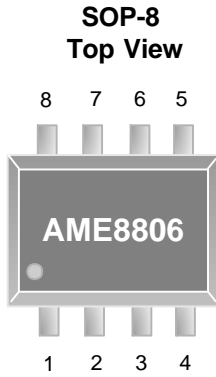
**■ Pin Configuration**

**AME8806**

1. IN
2. GND
3. GND
4. EN
5. BYP
6. GND
7. GND
8. OUT

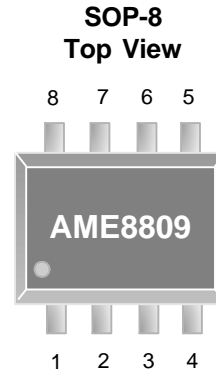
**\* Die Attach:  
Conductive Epoxy**

**AME8809**

1. EN
2. IN
3. OUT
4. BYP
5. GND
6. GND
7. GND
8. GND

**\* Die Attach:  
Conductive Epoxy**

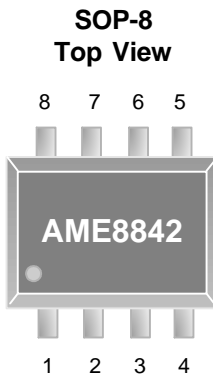
**AME8842**

1. PG
2. IN
3. OUT
4. EN
5. GND
6. GND
7. GND
8. GND

**\* Die Attach:  
Non-Conductive Epoxy**



# AME8806 / 8809 / 8842

# 600mA CMOS LDO

## ■ Ordering Information

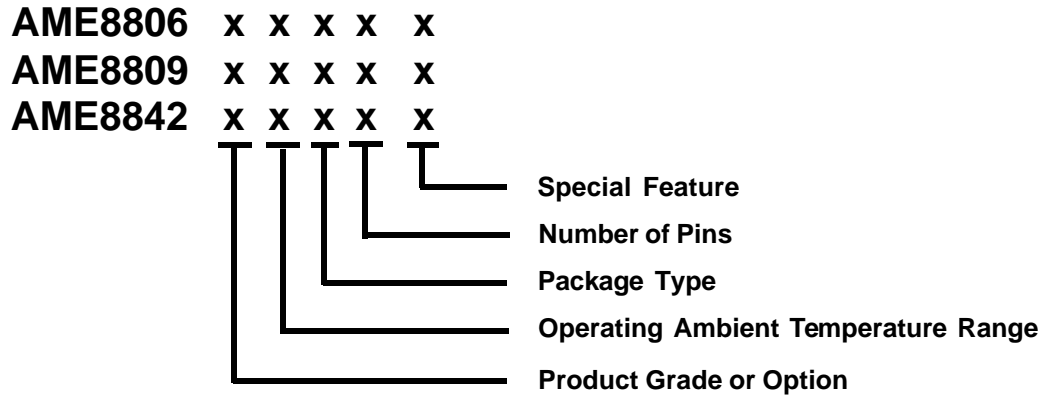

Product Grade or Option	Operating Ambient Temperature Range	Package Type	Number of Pins	Special Feature
A: 3.3V    1: 1.3V B: 3.0V    2: 2.0V C: 2.8V    3: 4.2V D: 2.5V    4: 4.0V E: 3.8V F: 3.6V G: 3.5V H: 2.7V I: 3.4V J: 2.85V K: 3.7V L: 1.5V M: 1.8V N: 2.9V O: 3.1V P: 4.1V Q: 4.75V R: 2.65V S: 5.0V U: 3.2V V: 3.15V W: 2.3V Y: 1.9V Z: 1.7V	E: -40°C to +85°C	H: SOP	A: 8	Z: Lead Free

**■ Ordering Information**

Part Number	Marking*	Output Voltage	Package	Operating Ambient Temperature Range
AME8806AEHA	8806 AEHA yyww	3.3V	SOP-8	- 40°C to +85°C
AME8806AEHAZ	8806 AEHA yyww	3.3V	SOP-8	- 40°C to +85°C
AME8806BEHA	8806 BEHA yyww	3.0V	SOP-8	- 40°C to +85°C
AME8806BEHAZ	8806 BEHA yyww	3.0V	SOP-8	- 40°C to +85°C
AME8806CEHA	8806 CEHA yyww	2.8V	SOP-8	- 40°C to +85°C
AME8806CEHAZ	8806 CEHA yyww	2.8V	SOP-8	- 40°C to +85°C
AME8806DEHA	8806 DEHA yyww	2.5V	SOP-8	- 40°C to +85°C
AME8806DEHAZ	8806 DEHA yyww	2.5V	SOP-8	- 40°C to +85°C
AME8806EEHA	8806 EEHA yyww	3.8V	SOP-8	- 40°C to +85°C
AME8806EEHAZ	8806 EEHA yyww	3.8V	SOP-8	- 40°C to +85°C
AME8806FEHA	8806 FEHA yyww	3.6V	SOP-8	- 40°C to +85°C
AME8806FEHAZ	8806 FEHA yyww	3.6V	SOP-8	- 40°C to +85°C

Note: yyww represents the date code

\* A line on top of the first letter represents lead free plating such as  $\overline{8806}$

Please consult AME sales office or authorized Rep./Distributor for output voltage and package type availability.

**■ Ordering Information (contd.)**

Part Number	Marking*	Output Voltage	Package	Operating Ambient Temperature Range
AME8806GEHA	8806 GEHA yyww	3.5V	SOP-8	- 40°C to +85°C
AME8806GEHAZ	8806 GEHA yyww	3.5V	SOP-8	- 40°C to +85°C
AME8806HEHA	8806 HEHA yyww	2.7V	SOP-8	- 40°C to +85°C
AME8806HEHAZ	8806 HEHA yyww	2.7V	SOP-8	- 40°C to +85°C
AME8806IEHA	8806 IEHA yyww	3.4V	SOP-8	- 40°C to +85°C
AME8806IEHAZ	8806 IEHA yyww	3.4V	SOP-8	- 40°C to +85°C
AME8806JEHA	8806 JEHA yyww	2.85V	SOP-8	- 40°C to +85°C
AME8806JEHAZ	8806 JEHA yyww	2.85V	SOP-8	- 40°C to +85°C
AME8806KEHA	8806 KEHA yyww	3.7V	SOP-8	- 40°C to +85°C
AME8806KEHAZ	8806 KEHA yyww	3.7V	SOP-8	- 40°C to +85°C
AME8806LEHA	8806 LEHA yyww	1.5V	SOP-8	- 40°C to +85°C
AME8806LEHAZ	8806 LEHA yyww	1.5V	SOP-8	- 40°C to +85°C
AME8806MEHA	8806 MEHA yyww	1.8V	SOP-8	- 40°C to +85°C
AME8806MEHAZ	8806 MEHA yyww	1.8V	SOP-8	- 40°C to +85°C

**■ Ordering Information (contd.)**

Part Number	Marking*	Output Voltage	Package	Operating Ambient Temperature Range
AME8806NEHA	8806 NEHA yyww	2.9V	SOP-8	- 40°C to +85°C
AME8806NEHAZ	8806 NEHA yyww	2.9V	SOP-8	- 40°C to +85°C
AME8806OEHA	8806 OEHA yyww	3.1V	SOP-8	- 40°C to +85°C
AME8806OEHAZ	8806 OEHA yyww	3.1V	SOP-8	- 40°C to +85°C
AME8809AEHA	8809 AEHA yyww	3.3V	SOP-8	- 40°C to +85°C
AME8809AEHAZ	8809 AEHA yyww	3.3V	SOP-8	- 40°C to +85°C
AME8809BEHA	8809 BEHA yyww	3.0V	SOP-8	- 40°C to +85°C
AME8809BEHAZ	8809 BEHA yyww	3.0V	SOP-8	- 40°C to +85°C
AME8809CEHA	8809 CEHA yyww	2.8V	SOP-8	- 40°C to +85°C
AME8809CEHAZ	8809 CEHA yyww	2.8V	SOP-8	- 40°C to +85°C
AME8809DEHA	8809 DEHA yyww	2.5V	SOP-8	- 40°C to +85°C
AME8809DEHAZ	8809 DEHA yyww	2.5V	SOP-8	- 40°C to +85°C
AME8809EEHA	8809 EEHA yyww	3.8V	SOP-8	- 40°C to +85°C
AME8809EEHAZ	8809 EEHA yyww	3.8V	SOP-8	- 40°C to +85°C

**■ Ordering Information (contd.)**

Part Number	Marking*	Output Voltage	Package	Operating Ambient Temperature Range
AME8809FEHA	8809 FEHA yyww	3.6V	SOP-8	- 40°C to +85°C
AME8809FEHAZ	8809 FEHA yyww	3.6V	SOP-8	- 40°C to +85°C
AME8809GEHA	8809 GEHA yyww	3.5V	SOP-8	- 40°C to +85°C
AME8809GEHAZ	8809 GEHA yyww	3.5V	SOP-8	- 40°C to +85°C
AME8809HEHA	8809 HEHA yyww	2.7V	SOP-8	- 40°C to +85°C
AME8809HEHAZ	8809 HEHA yyww	2.7V	SOP-8	- 40°C to +85°C
AME8809IEHA	8809 IEHA yyww	3.4V	SOP-8	- 40°C to +85°C
AME8809IEHAZ	8809 IEHA yyww	3.4V	SOP-8	- 40°C to +85°C
AME8809JEHA	8809 JEHA yyww	2.85V	SOP-8	- 40°C to +85°C
AME8809JEHAZ	8809 JEHA yyww	2.85V	SOP-8	- 40°C to +85°C
AME8809KEHA	8809 KEHA yyww	3.7V	SOP-8	- 40°C to +85°C
AME8809KEHAZ	8809 KEHA yyww	3.7V	SOP-8	- 40°C to +85°C
AME8809LEHA	8809 LEHA yyww	1.5V	SOP-8	- 40°C to +85°C
AME8809LEHAZ	8809 LEHA yyww	1.5V	SOP-8	- 40°C to +85°C

**■ Ordering Information (contd.)**

Part Number	Marking*	Output Voltage	Package	Operating Ambient Temperature Range
AME8809MEHA	8809 MEHA yyww	1.8V	SOP-8	- 40°C to +85°C
AME8809MEHAZ	8809 MEHA yyww	1.8V	SOP-8	- 40°C to +85°C
AME8809NEHA	8809 NEHA yyww	2.9V	SOP-8	- 40°C to +85°C
AME8809NEHAZ	8809 NEHA yyww	2.9V	SOP-8	- 40°C to +85°C
AME8809OEHA	8809 OEHA yyww	3.1V	SOP-8	- 40°C to +85°C
AME8809OEHAZ	8809 OEHA yyww	3.1V	SOP-8	- 40°C to +85°C
AME8842AEHA	8842 AEHA yyww	3.3V	SOP-8	- 40°C to +85°C
AME8842AEHAZ	8842 AEHA yyww	3.3V	SOP-8	- 40°C to +85°C
AME8842BEHA	8842 BEHA yyww	3.0V	SOP-8	- 40°C to +85°C
AME8842BEHAZ	8842 BEHA yyww	3.0V	SOP-8	- 40°C to +85°C
AME8842CEHA	8842 CEHA yyww	2.8V	SOP-8	- 40°C to +85°C
AME8842CEHAZ	8842 CEHA yyww	2.8V	SOP-8	- 40°C to +85°C
AME8842DEHA	8842 DEHA yyww	2.5V	SOP-8	- 40°C to +85°C
AME8842DEHAZ	8842 DEHA yyww	2.5V	SOP-8	- 40°C to +85°C



**■ Ordering Information (contd.)**

Part Number	Marking*	Output Voltage	Package	Operating Ambient Temperature Range
AME8842EEHA	8842 EEHA yyww	3.8V	SOP-8	- 40°C to +85°C
AME8842EEHAZ	8842 EEHA yyww	3.8V	SOP-8	- 40°C to +85°C
AME8842FEHA	8842 FEHA yyww	3.6V	SOP-8	- 40°C to +85°C
AME8842FEHAZ	8842 FEHA yyww	3.6V	SOP-8	- 40°C to +85°C
AME8842GEHA	8842 GEHA yyww	3.5V	SOP-8	- 40°C to +85°C
AME8842GEHAZ	8842 GEHA yyww	3.5V	SOP-8	- 40°C to +85°C
AME8842HEHA	8842 HEHA yyww	2.7V	SOP-8	- 40°C to +85°C
AME8842HEHAZ	8842 HEHA yyww	2.7V	SOP-8	- 40°C to +85°C
AME8842IEHA	8842 IEHA yyww	3.4V	SOP-8	- 40°C to +85°C
AME8842IEHAZ	8842 IEHA yyww	3.4V	SOP-8	- 40°C to +85°C
AME8842JEHA	8842 JEHA yyww	2.85V	SOP-8	- 40°C to +85°C
AME8842JEHAZ	8842 JEHA yyww	2.85V	SOP-8	- 40°C to +85°C
AME8842KEHA	8842 KEHA yyww	3.7V	SOP-8	- 40°C to +85°C
AME8842KEHAZ	8842 KEHA yyww	3.7V	SOP-8	- 40°C to +85°C

**■ Ordering Information (contd.)**

<b>Part Number</b>	<b>Marking*</b>	<b>Output Voltage</b>	<b>Package</b>	<b>Operating Ambient Temperature Range</b>
AME8842LEHA	8842 LEHA yyww	1.5V	SOP-8	- 40°C to +85°C
AME8842LEHAZ	8842 LEHA yyww	1.5V	SOP-8	- 40°C to +85°C
AME8842MEHA	8842 MEHA yyww	1.8V	SOP-8	- 40°C to +85°C
AME8842MEHAZ	8842 MEHA yyww	1.8V	SOP-8	- 40°C to +85°C
AME8842NEHA	8842 NEHA yyww	2.9V	SOP-8	- 40°C to +85°C
AME8842NEHAZ	8842 NEHA yyww	2.9V	SOP-8	- 40°C to +85°C
AME8842OEHA	8842 OEHA yyww	3.1V	SOP-8	- 40°C to +85°C
AME8842OEHAZ	8842 OEHA yyww	3.1V	SOP-8	- 40°C to +85°C

**■ Absolute Maximum Ratings**

Parameter	Maximum	Unit
Input Voltage	8	V
Output Current	$P_D / (V_{IN} - V_O)$	A
Input, Output Voltage	GND - 0.3 to $V_{IN} + 0.3$	V
ESD Classification	B*	

Caution: Stress above the listed absolute maximum rating may cause permanent damage to the device.

\*HBM B: 2000V~3999V

**■ Recommended Operating Conditions**

Parameter	Symbol	Rating	Unit
Ambient Temperature Range	$T_A$	- 40 to +85	°C
Junction Temperature Range	$T_J$	- 40 to +125	°C

**■ Thermal Information**

Parameter	Package	Die Attach	Symbol	Maximum	Unit
Thermal Resistance (Junction to Case)	*SOP-8	Conductive Epoxy	$\theta_{JA}$	60	°C / W
		Non-Conductive Epoxy		N/A	
Thermal Resistance (Junction to Ambient)	SOP-8	Conductive Epoxy	$\theta_{JC}$	150	°C / W
		Non-Conductive Epoxy		N/A	
Internal Power Dissipation	SOP-8	Conductive Epoxy	$P_D$	810	mW
		Non-Conductive Epoxy		N/A	
Maximum Junction Temperature				150	°C
Solder Iron(10 Sec)**				350	°C

\* Measure  $\theta_{JC}$  on center of molding compound if IC has no tab.

\*\* MIL-STD-202G 210F

**■ Electrical Specifications**

TA = 25°C unless otherwise noted

Parameter	Symbol	Test Condition	Min	Typ	Max	Units	
Input Voltage	$V_{IN}$		Note 1		7	V	
Output Voltage Accuracy	$V_O$	$I_O=1mA$	-1.5		1.5	%	
Dropout Voltage	$V_{DROPOUT}$	$I_O=600mA$ $V_O=V_{O(NOM)}-2.0\%$	$1.3V \leq V_{O(NOM)} \leq 1.4V$	See chart	1900	mV	
			$1.4V < V_{O(NOM)} \leq 2.0V$		1400		
			$2.0V < V_{O(NOM)} \leq 2.8V$		800		
			$2.8V < V_{O(NOM)}$		600		
Output Current	$I_O$	$V_O > 1.2V$	600			mA	
Current Limit	$I_{LIM}$	$V_O > 1.2V$	600	800		mA	
Short Circuit Current	$I_{SC}$	$V_O < 0.8V$		300	600	mA	
Quiescent Current	$I_Q$	$I_O=0mA$		30	50	$\mu A$	
Ground Pin Current	$I_{GND}$	$I_O=1mA$ to 600mA		35		$\mu A$	
Line Regulation	$REG_{LINE}$	$I_O=1mA$ $V_{IN}=V_O+1$ to $V_O+2$	$1.3V \leq V_O \leq 1.4V$	-0.2		0.2	%
			$1.4V < V_O \leq 2.0V$	-0.15		0.15	
			$2.0V \leq V_O < 4.0V$	-0.1	0.02	0.1	
			$V_O \geq 4.0V$	-0.4	0.2	0.4	
Load Regulation	$REG_{LOAD}$	$I_O=1mA$ to 600mA		0.2	1	%	
Over Temperature Shutdown	OTS			150		°C	
Over Temperature Hysteresis	OTH			30		°C	
$V_O$ Temperature Coefficient	TC			30		ppm/°C	
Power Supply Rejection	PSRR	$I_O=100mA$ $C_O=2.2\mu F$ ceramic $C_{BYP}=0.01\mu F$	$f=1kHz$		75	dB	
			$f=10kHz$		55		
			$f=100kHz$		30		
Output Voltage Noise	eN	$f=10Hz$ to 100kHz $I_O=10mA$ , $C_{BYP}=0.01\mu F$			30	$\mu V_{rms}$	
EN Input Threshold	$V_{EH}$	$V_{IN}=2.7V$ to 7V	2.0		$V_{in}$	V	
	$V_{EL}$	$V_{IN}=2.7V$ to 7V	0		0.4	V	
EN Input Bias Current	$I_{EH}$	$V_{EN}=V_{IN}$ , $V_{IN}=2.7V$ to 7V			0.1	$\mu A$	
	$I_{EL}$	$V_{EN}=0V$ , $V_{IN}=2.7V$ to 7V			0.5	$\mu A$	
Shutdown Supply Current	$I_{SD}$	$V_{IN}=5V$ , $V_O=0V$ , $V_{EN} < V_{EL}$		0.5	1	$\mu A$	
PG Leakage Current	$I_{LC}$	$V_{PG}=7V$			1	$\mu A$	
PG Voltage Rating	$V_{PG}$	$V_O$ in regulation			7	V	
PG Voltage Low	$V_{OL}$	$I_{SINK}=0.4mA$			0.4	V	

 Note1:  $V_{IN(min)} = V_{OUT} + V_{DROPOUT}$ 

Note2: To prevent the Short Circuit Current protection feature from being prematurely activated, the input voltage must be applied before a current source load is applied.

## ■ Detailed Description

The AME8806/8809/8842 family of CMOS regulators contain a PMOS pass transistor, voltage reference, error amplifier, over-current protection, and thermal shutdown.

The P-channel pass transistor receives data from the error amplifier, over-current shutdown, and thermal protection circuits. During normal operation, the error amplifier compares the output voltage to a precision reference. Over-current and Thermal shutdown circuits become active when the junction temperature exceeds 150°C, or the current exceeds 600mA. During thermal shutdown, the output voltage remains low. Normal operation is restored when the junction temperature drops below 120°C.

The AME8806/8809/8842 switches from voltage mode to current mode when the load exceeds the rated output current. This prevents over-stress. The AME8806/8809/8842 also incorporates current foldback to reduce power dissipation when the output is short circuited. This feature becomes active when the output drops below 0.8 volts, and reduces the current flow by 65%. Full current is restored when the voltage exceeds 0.8 volts.

## ■ External Capacitors

The AME8806/8809/8842 is stable with an output capacitor to ground of 2.2 $\mu$ F or greater. Ceramic capacitors have the lowest ESR, and will offer the best AC performance. Conversely, Aluminum Electrolytic capacitors exhibit the highest ESR, resulting in the poorest AC response. Unfortunately, large value ceramic capacitors are comparatively expensive. One option is to parallel a 0.1 $\mu$ F ceramic capacitor with a 10 $\mu$ F Aluminum Electrolytic. The benefit is low ESR, high capacitance, and low overall cost.

A second capacitor is recommended between the input and ground to stabilize  $V_{in}$ . The input capacitor should be at least 0.1 $\mu$ F to have a beneficial effect.

A third capacitor can be connected between the BY-PASS pin and GND. This capacitor can be a low cost Polyester Film variety between the value of 0.001 ~ 0.01 $\mu$ F. A larger capacitor improves the AC ripple rejection, but also makes the output come up slowly. This "Soft" turn-on is desirable in some applications to limit turn-on surges.

All capacitors should be placed in close proximity to the pins. A "Quiet" ground termination is desirable. This can be achieved with a "Star" connection.

## ■ Enable

The Enable pin normally floats high. When actively, pulled low, the PMOS pass transistor shuts off, and all internal circuits are powered down. In this state, the quiescent current is less than 1 $\mu$ A. This pin behaves much like an electronic switch.

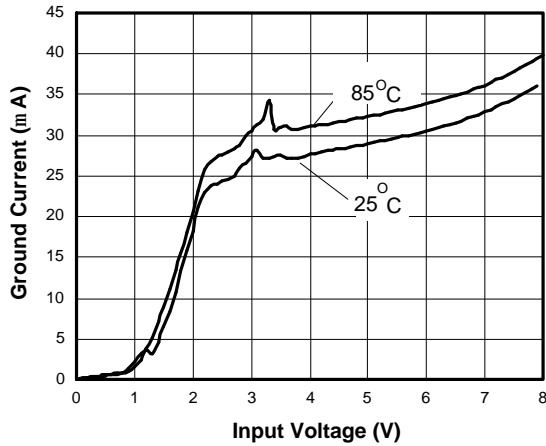
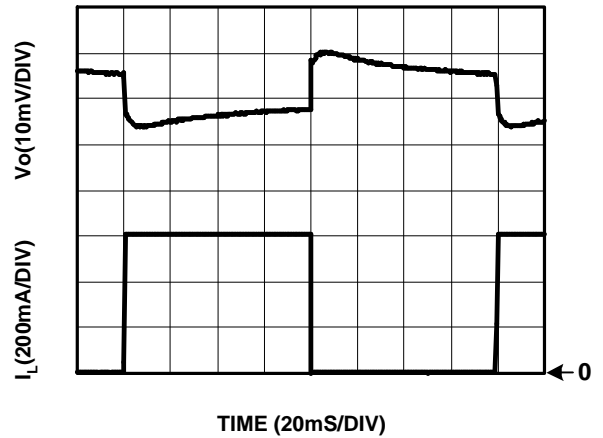
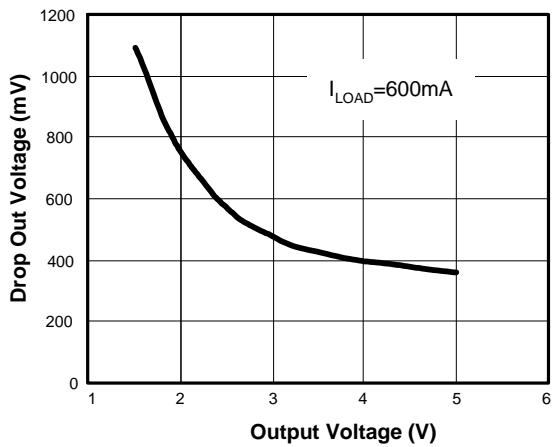
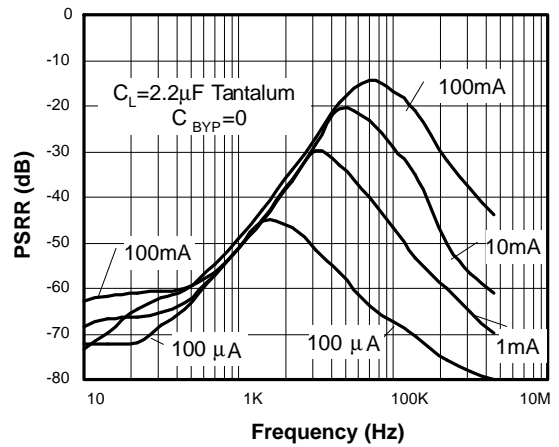
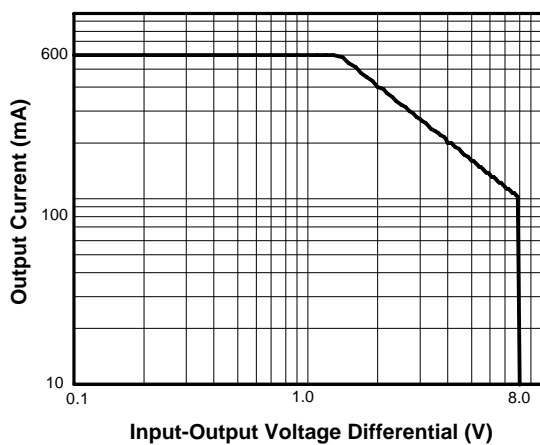
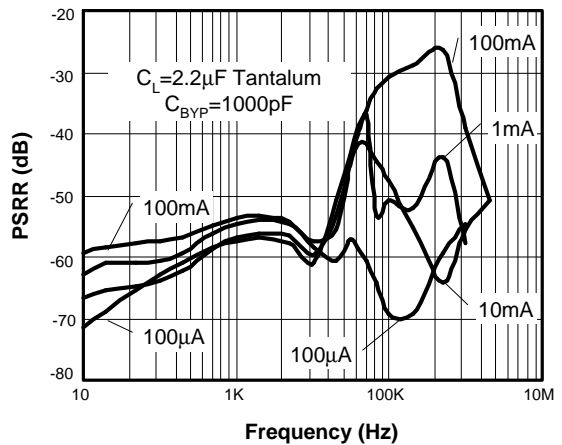
**Ground Current vs. Input Voltage**

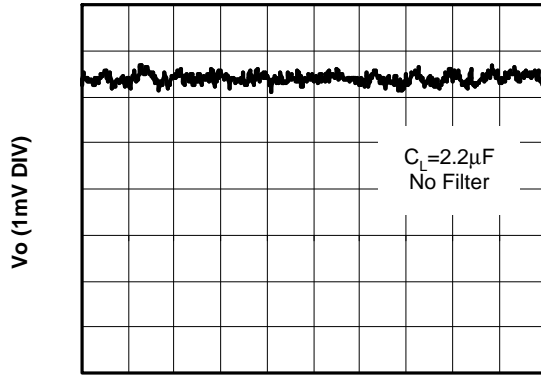
**Load Step (1mA-600mA)**

**Drop Out Voltage vs. Output Voltage**

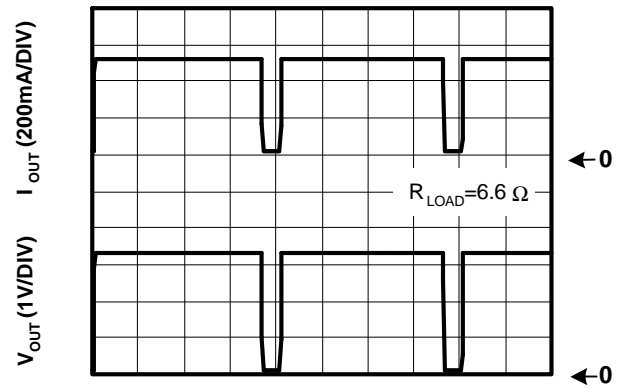
**Power Supply Rejection Ratio**

**Safe Operating Area**

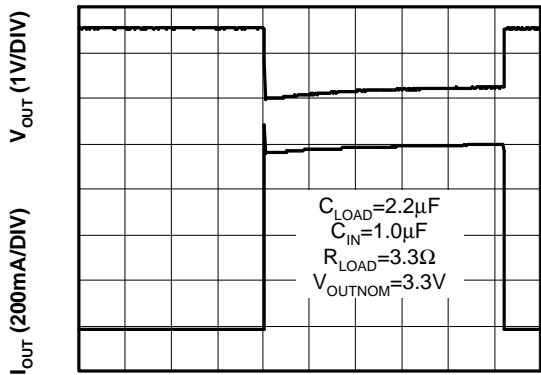
**Power Supply Rejection Ratio**

**Noise Measurement**

TIME (20ms/DIV)

**Overtemperature Shutdown**

TIME (0.5Sec/DIV)

**Current Limit Response**

TIME (2mS/DIV)

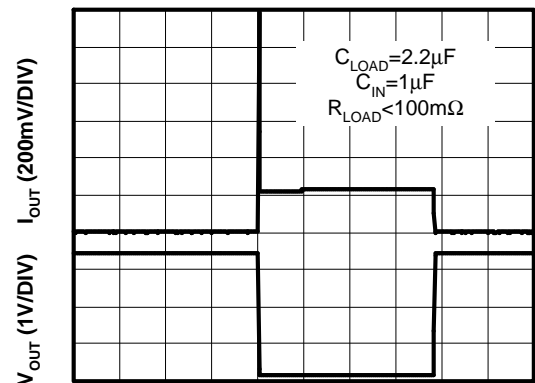
**Short Circuit Response**

TIME (2mS/DIV)

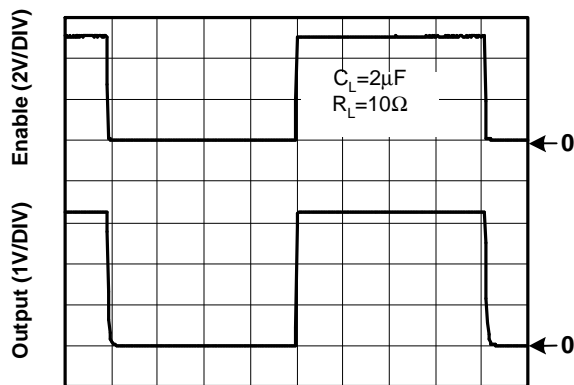
**Chip Enable Transient Response**

TIME (1mS/DIV)

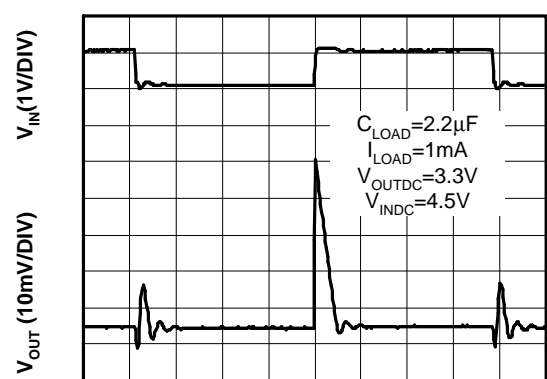
**Line Transient Response**

TIME (200mS/DIV)

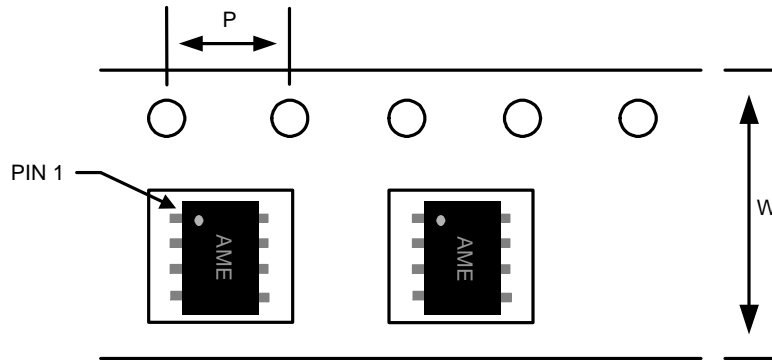
**■ Tape and Reel Dimension**
**SOP-8**

**Carrier Tape. Number of Components Per Reel and Reel Size**

Package	Carrier Width (W)	Pitch (P)	Part Per Full Reel	Reel Size
SOP-8	12.0±0.1 mm	4.0±0.1 mm	2500pcs	330±1 mm

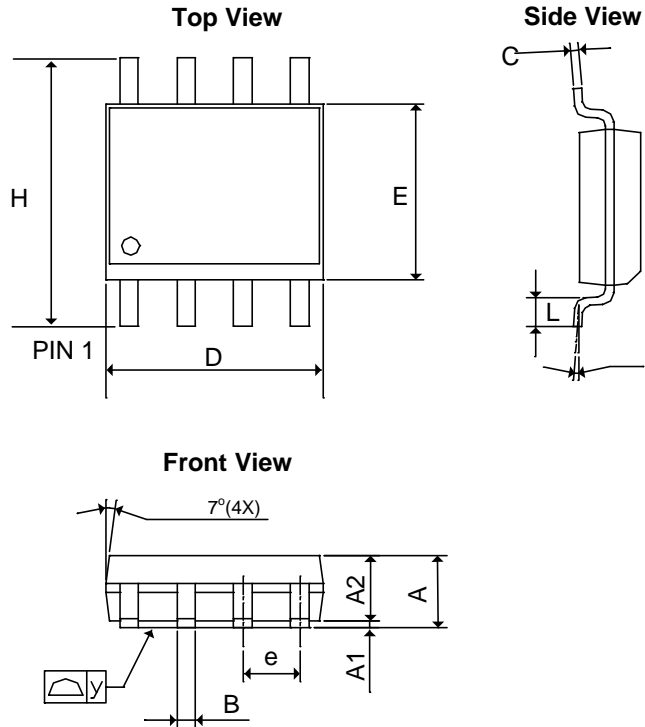

**■ Package Dimension**
**SOP-8**

SYMBOLS	MILLIMETERS		INCHES	
	MIN	MAX	MIN	MAX
A	1.35	1.75	0.05315	0.0689
A <sub>1</sub>	0.10	0.30	0.00394	0.01181
A <sub>2</sub>	1.473 REF		0.05799 REF	
B	0.33	0.51	0.01299	0.02008
C	0.19	0.25	0.00748	0.00984
D	4.80	5.33	0.18898	0.20984
E	3.80	4.00	0.14961	0.15748
e	1.27 BSC		0.05000 BSC	
L	0.40	1.27	0.01575	0.05000
H	5.80	6.30	0.22835	0.24803
y	-	0.10	-	0.00394
q	0°	8°	0°	8°



**www.ame.com.tw**  
**E-Mail: sales@ame.com.tw**

Life Support Policy:

These products of AME, Inc. are not authorized for use as critical components in life-support devices or systems, without the express written approval of the president of AME, Inc.

AME, Inc. reserves the right to make changes in the circuitry and specifications of its devices and advises its customers to obtain the latest version of relevant information.

© AME, Inc. , November 2008

Document: 2006/2095-DS8806/8809/8842-H.02

## **Corporate Headquarter**

### **AME, Inc.**

2F, 302 Rui-Guang Road, Nei-Hu District

Taipei 114, Taiwan.

Tel : 886 2 2627-8687

Fax: 886 2 2659-2989