



**SPECIFICATION
FOR
LCD MODULE**

**MODULE NO: AMC128128Q-G-W6NFDW
REVISION NO: 00**

Customer's Approval:

--

	SIGNATURE	DATE
PREPARED BY (RD ENGINEER)	JLT	2009-11-10
CHECKED BY	YHW	2009-11-10
APPROVED BY	HSH	2009-11-10

Table of Contents

1 General Specifications	3
2 Mechanical Diagram	4
3 I/O Terminal	6
3.1 Pin Description.....	6
3.2 Block Diagram	7
4. Electro-optical Specifications	8
4.1 Absolute Maximum Ratings.....	8
4.2 Optical Characteristics ⁽¹⁾	8
4.3 Electrical Characteristics	9
4.4 Timing Characteristics	10
5 Programming.....	15
5.1 Instruction Table:.....	15
Appendix.....	18
1 Packing Method (TBD)	18
2 Definitions of Optical Characteristic.....	19
2.1 Contrast Ratio Test	19
2.2 Response time.....	20
2.3 Viewing Angle	21
3 Quality Units	22
3.1 Visual and Technological Inspection	22
3.2 Sampling Plan.....	22
4 Inspection Criteria	23
5 Caution for using	26
6 Reliability-TEST.....	27
6.1. Standard Specifications for Reliability	27
6.2 Life Time.....	27

Revision History

Rev.	Comment	Date
A00	Original Version	2009-11-10

1 General Specifications

Item	<input checked="" type="checkbox"/> Standard Value	Unit	
Display Pattern	<input checked="" type="checkbox"/> Graphic <input type="checkbox"/> _____	<input type="checkbox"/> Character <input type="checkbox"/> with ICON	<input type="checkbox"/> Segment
Color	<input type="checkbox"/> Mono.	<input checked="" type="checkbox"/> Grayscale	<input type="checkbox"/> _____
Module Dimension (W x H x T)	71.3 (W) × 173.41(H)×6.635 (T)		mm
Viewing Area (W x H)	65.5×60.51		mm
Active Area (W x H)	56.3×56.3		mm
Character Size (W x H)	\		mm
Character Pitch (W x H)	\		mm
DOT Size (W x H)	0.42×0.42		mm
DOT Pitch (W x H)	0.44×0.44		mm
LCD Type	<input type="checkbox"/> TN, Positive <input type="checkbox"/> TN, Negative		
	<input type="checkbox"/> HTN, Positive <input type="checkbox"/> HTN, Negative		
	<input type="checkbox"/> S TN, Yellow-Green <input type="checkbox"/> STN, Gray <input type="checkbox"/> STN, Blue		
	<input checked="" type="checkbox"/> FSTN, Positive <input type="checkbox"/> FSTN, Negative		
	<input type="checkbox"/> _____ <input type="checkbox"/> FM LCD <input type="checkbox"/> Color STN		
Polarizer Type	<input checked="" type="checkbox"/> Transflective	<input type="checkbox"/> Transmissive	<input type="checkbox"/> Reflective
	<input checked="" type="checkbox"/> Anti-Glare		
View Direction	<input checked="" type="checkbox"/> 6H	<input type="checkbox"/> 12H	<input type="checkbox"/> _____
LCD Controller & Driver	NT7528		
LCD Driving Method	1/128duty, 1/12bias		
Interface Type	Serial <input checked="" type="checkbox"/> I ² C <input checked="" type="checkbox"/> 4-line SPI <input checked="" type="checkbox"/> 3-line SPI <input type="checkbox"/> _____		
	Parallel <input checked="" type="checkbox"/> 6800 <input checked="" type="checkbox"/> 8080 <input type="checkbox"/> 4-bit <input type="checkbox"/> _____		
Backlight Type	<input checked="" type="checkbox"/> LED <input type="checkbox"/> Bottom <input checked="" type="checkbox"/> Single Side <input type="checkbox"/> Dual Side		
	<input type="checkbox"/> _____ <input type="checkbox"/> EL <input type="checkbox"/> CCFL		
Backlight Color	<input type="checkbox"/> Yellow-Green <input checked="" type="checkbox"/> White <input type="checkbox"/> Amber		
	<input type="checkbox"/> Blue <input type="checkbox"/> Red <input type="checkbox"/> _____		
EL/CCFL Driver type	<input type="checkbox"/> Build-in <input type="checkbox"/> External		
DC-DC Converter	<input type="checkbox"/> Build-in <input type="checkbox"/> External		
Operation Temperature	T _{OPL} = -20 T _{OPH} = +70		°C
Storage Temperature	T _{STL} = -25 T _{STH} = +75		°C

2 Mechanical Diagram

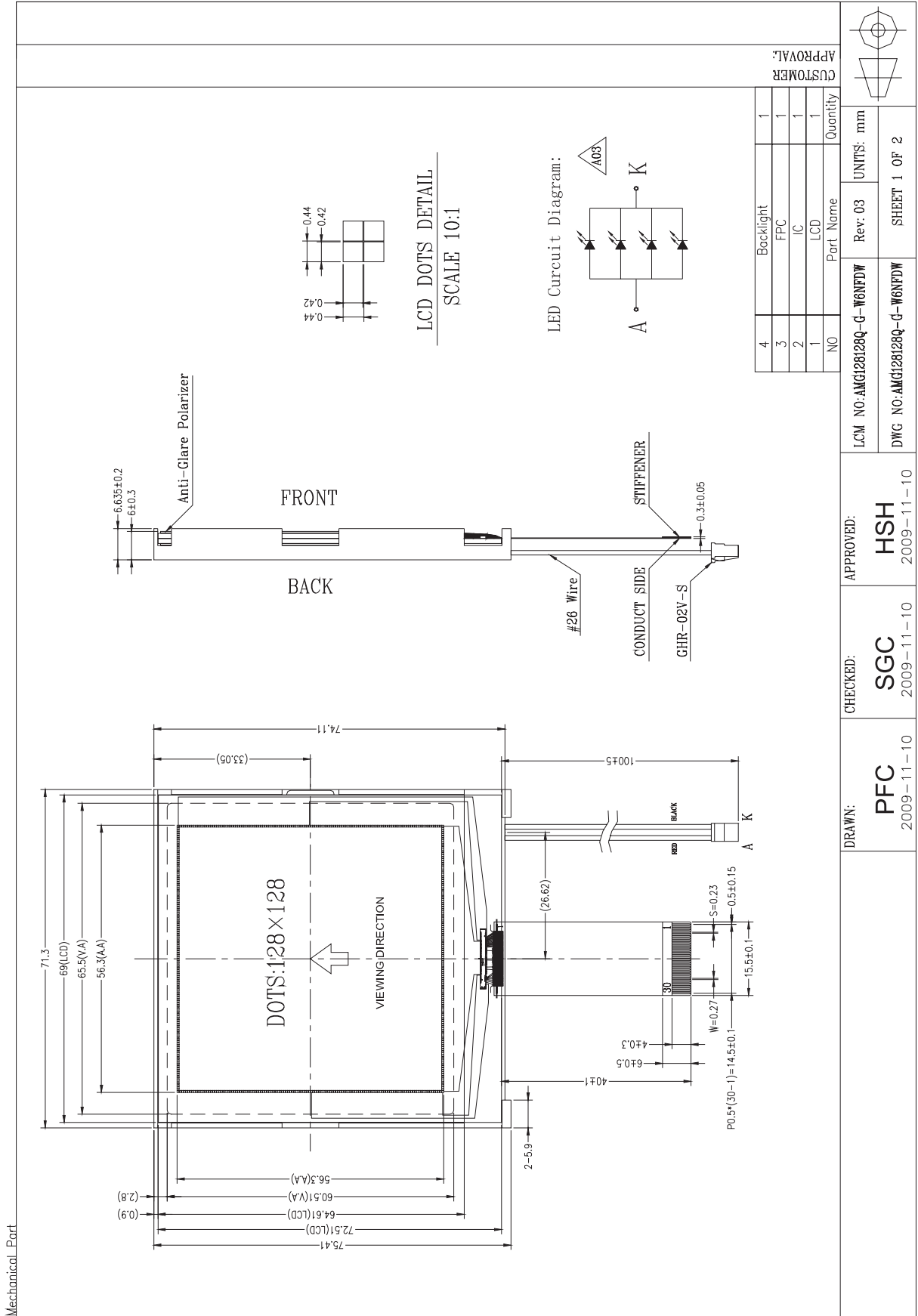

Electrical_Pard

Block_Diagram:

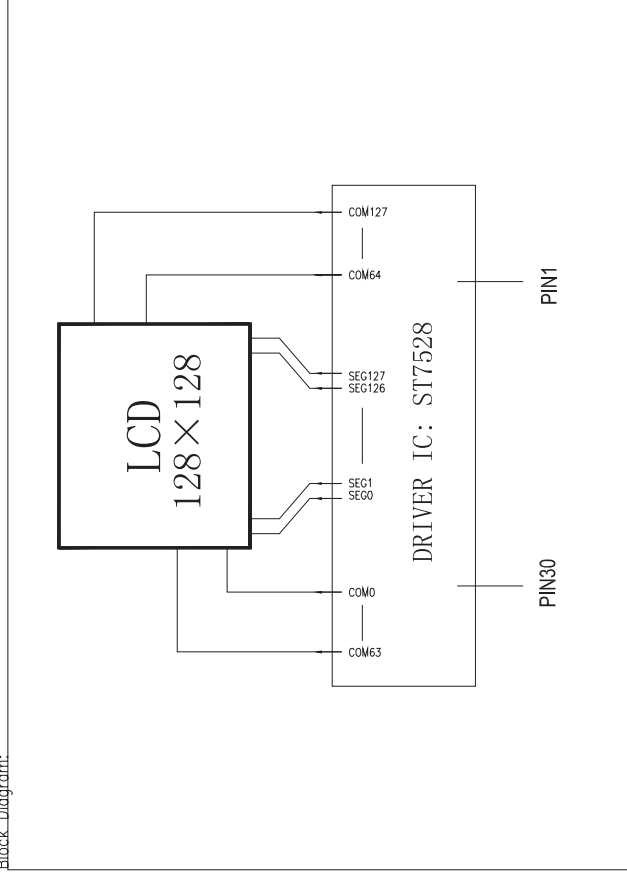

DISPLAY TYPE:FSTN,Transflective,Positive
 VIEWING DIRECTION: 6:00
 DRIVER IC: ST7528
 LOGIC VOLTAGE: 3.0±0.3V
 LCD DRIVE VOLTAGE(Vlcd): 13.5V
 DRIVING METHOD: 1/128 DUTY, 1/12 BIAS
 BACKLIGHT: 4-White LEDs
 VLED=3.2±0.2V
 ILED=45mA
 OPERATING TEMPERATURE: -20° ~ +70°C
 STORAGE TEMPERATURE: -25° ~ +75°C
 INTERFACE CONNECTOR: FPC
 ALL UNMARKED TOLERANCE: ±0.3mm



Pin_Description:

PIN	Symbol
1	PS0
2	PS1
3	PS2
4	CSB
5	RST
6	A0
7	RW-WR
8	E-RD
9	DB0
10	DB1
11	DB2
12	DB3
13	DB4
14	DB5
15	DB6
16	DB7
17	VDD
18	VDD
19	VSS
20	VSS
21	VOUT-OUT
22	VOUT-IN
23	V4
24	V3
25	V2
26	V1
27	V0
28	VR
29	INTRS
30	NC

- A03: Modify LED Circuit Diagram.
 - A02: Modify ITO Layout.
 - A01: Modify Backlight and FPC interface.
 - A00: Original Edition
- Revision History:

LCM NO: AMG128128Q-G-W6NFDW	Rev: 03	UNITS: mm
DWG NO: AMG128128Q-G-W6NFDW	SHEET 2 OF 2	

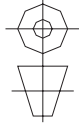

CUSTOMER APPROVAL:

DRAWN: PFC	CHECKED: YHW	APPROVED: HSH
2009-11-10	2009-11-10	2009-11-10

3 I/O Terminal

3.1 Pin Description

Pin NO.	Symbol	Function Description
1	PS0	Parallel / Serial data input select input
2	PS1	
3	PS2	
4	CSB	Chip select input pins
5	RST	Reset input pin
6	A0	Register select input pin
7	RW-WR	Read / Write execution control pin
8	E-RD	Read / Write execution control pin
9~16	D0~D7	8-bit bi-directional data bus
17~18	VDD	Power supply
19~20	VSS	Ground
21	VOUT-OUT	Supply Step-up output voltage
22	VOUT-IN	Voltage regulator Circuit Operating Voltage
23	V4	LCD driver supply voltages
24	V3	
25	V2	
26	V1	
27	V0	
28	VR	V0 voltage adjustment pin
29	INTRS	Internal resistor select pin
30	NC	Non connection

3.2 Block Diagram

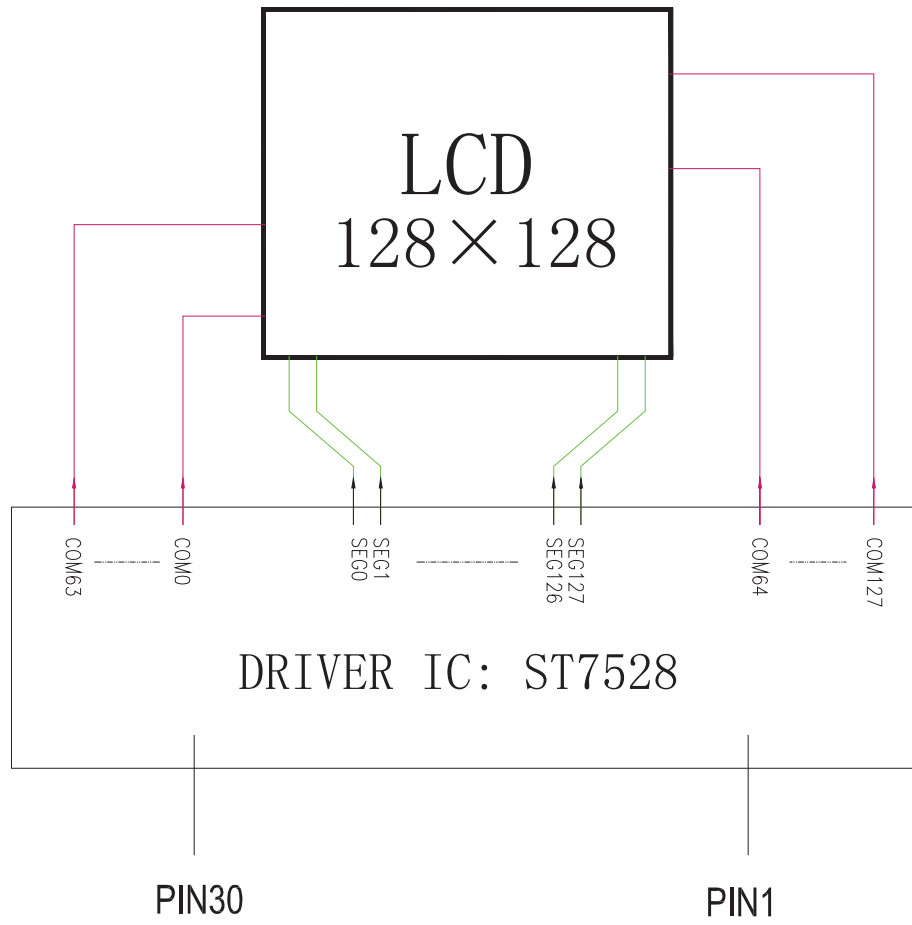

4. Electro-optical Specifications

4.1 Absolute Maximum Ratings

No	Item	Symbol	Min.	Max.	Unit
1	Supply Voltage For Logic	V_{DD}	-0.5	3.6	V
2	Supply Voltage For LCD Driver	V_{LCD}	3.5	15	V
3	Input Voltage range	V_I	-0.5	$V_{DD}+0.5$	V

Note: (1) V_{DD} and V_{LCD} are based on $V_{SS} = 0V$.

(2) Operating Temperature and Storage Temperature can be found in *1.General Specifications*.

4.2 Optical Characteristics⁽¹⁾

No	Item	Symbol	Condition	Min.	Typ.	Max.	Unit	
1	Contrast Ratio	Cr	$T_a=23\pm 3^{\circ}C$ $V_{LCD} = \text{Typ.}^{(2)}$	-	3.96	-	-	
2	Response time	Rise time	$T_a=23\pm 3^{\circ}C$	-	197	-	ms	
3		Fall time		-	213	-	ms	
4	Viewing Angle	3H	$\theta 3$	$Cr = 2$ $T_a=23\pm 3^{\circ}C$	-	23	-	Deg.
5		9H	$\theta 4$		-	24	-	Deg.
6		6H	$\theta 1$		-	31	-	Deg.
7		12H	$\theta 2$		-	29	-	Deg.
8	Brightness	Lv	$T_a=23\pm 3^{\circ}C$ $V_{LCD} = \text{Typ.}^{(2)}$	-	TBD	-	cd/m ²	
6	Luminance uniformity	Lu		75	-	-	%	

Note:

(1) See Appendix Definition of Optical Characteristics for detail.

(2) V_{LCD} can be found in 4.2 Electrical Characteristics *Supply Voltage for LCD Driver*

4.3 Electrical Characteristics

No	Item	Symbol	Condition	Min.	Typ.	Max.	Unit
1	Supply Voltage for Logic	$V_{DD}-V_{SS}$	-	2.7	3.0	3.3	V
2	Supply Voltage for LCD Driver	V_{LCD}	$T_a=23\pm 3^{\circ}C$	13.3	13.5	13.7	V
3	Supply Current for Logic	I_{DD}	-....	-	-	TBD	mA

5	Input High Voltage	V_{IH}	-	0.7VDD	-	VDD	V
6	Input Low Voltage	V_{IL}	-	0	-	0.3VDD	V
7	Output High Voltage	V_{OH}	-	0.7VDD	-	VDD	V
8	Output Low Voltage	V_{OL}	-	0	-	0.3VDD	V

9	Supply Current for LED Backlight	I_{LED}	$V_{LED} = \text{Typ.}$ $T_a=23\pm 3^{\circ}C$	-	45	-	mA
10	Supply Voltage for LED Backlight	V_{LED}	$I_{LED} = \text{Typ.}$ $T_a=23\pm 3^{\circ}C$	3.0	3.2	3.4	V

4.4 Timing Characteristics

4.4.1 System Bus Read/Write Characteristics 1 (For the 8080 Series MPU)

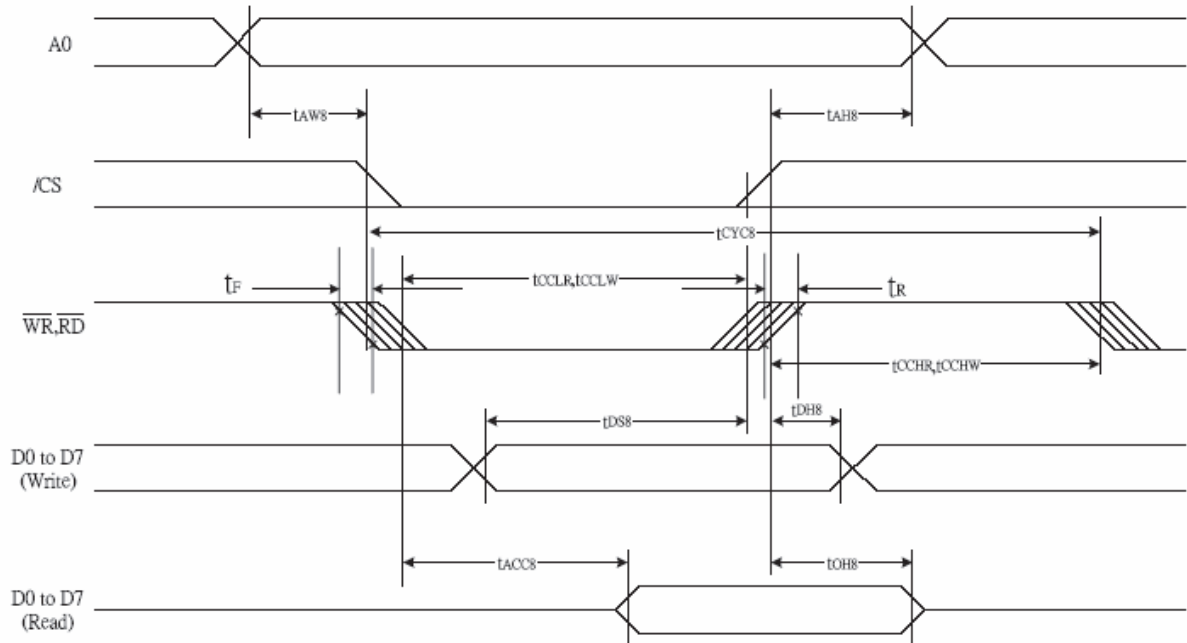

(VDD = 3.3V, Ta = -30~85°C)

Item	Signal	Symbol	Condition	Rating		Units
				Min.	Max.	
Address hold time	A0	tAH8		0	—	ns
Address setup time		tAW8		0	—	
System cycle time		tCYC8		240	—	
Enable L pulse width (WRITE)	WR	tCCLW		80	—	
Enable H pulse width (WRITE)		tCCHW		80	—	
Enable L pulse width (READ)	RD	tCCLR		140	—	
Enable H pulse width (READ)		tCCHR		80	—	
WRITE Data setup time	D0 to D7	tDS8		40	—	
WRITE Data hold time		tDH8		10	—	
READ access time		tACC8	CL = 100 pF	—	70	
READ Output disable time		tOH8	CL = 100 pF	5	50	
tF				—	10	
tR				—	10	

4.4.2 System Bus Read/Write Characteristics 1 (For the 6800 Series MPU)

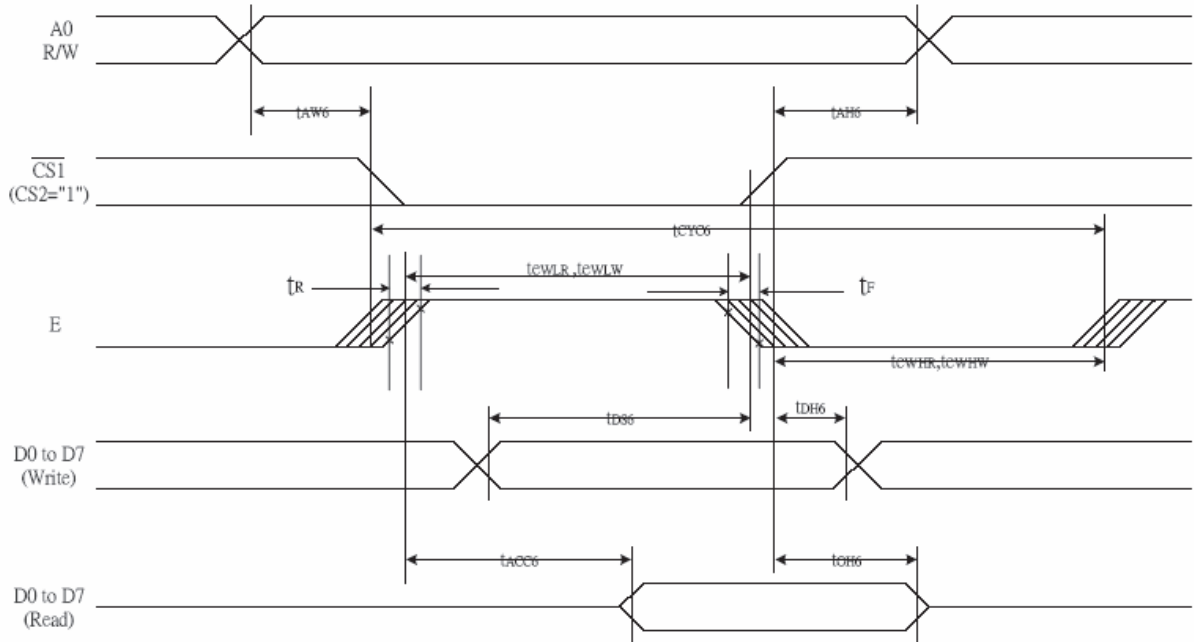

($V_{DD} = 3.3\text{ V}$, $T_a = -30\sim 85^\circ\text{C}$)

Item	Signal	Symbol	Condition	Rating		Units
				Min.	Max.	
Address hold time	A0	tAH6		0	—	ns
Address setup time		tAW6		0	—	
System cycle time		tCYC6		240	—	
Enable L pulse width (WRITE)	E_WR	tEWLW		80	—	
Enable H pulse width (WRITE)		tEWHW		80	—	
Enable L pulse width (READ)	E_RD	tEWLR		80	—	
Enable H pulse width (READ)		tEWHR		140	—	
WRITE Data setup time	D0 to D7	tDS6		40	—	
WRITE Data hold time		tDH6		10	—	
READ access time		tACC6	CL = 100 pF	—	70	
READ Output disable time		tOH6	CL = 100 pF	5	50	
tF				—	10	
tR				—	10	

4.4.3 SERIAL INTERFACE (4-Line Interface)

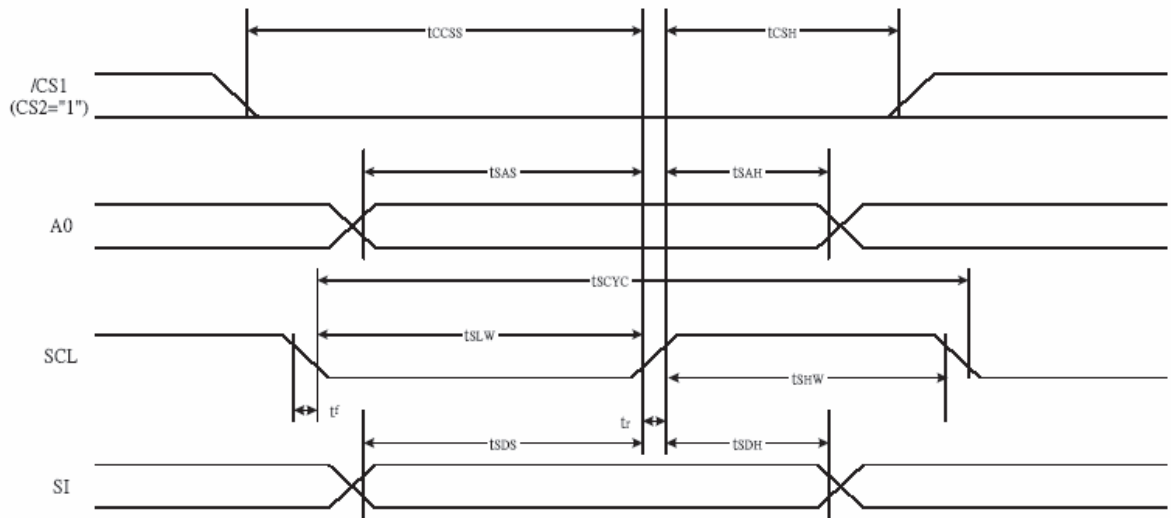

(V_{DD}=3.3V, Ta=-30~85°C)

Item	Signal	Symbol	Condition	Rating		Units
				Min.	Max.	
Serial Clock Period	SCL	tSCYC		50	—	ns
SCL "H" pulse width		tSHW		25	—	
SCL "L" pulse width		tSLW		25	—	
Address setup time	A0	tSAS		20	—	
Address hold time		tSAH		10	—	
Data setup time	SI	tSDS		20	—	
Data hold time		tSDH		10	—	
CS-SCL time	CSB	tCSS		20	—	
CS-SCL time		tCSH		40	—	

4.4.4 SERIAL INTERFACE(3-Line Interface)

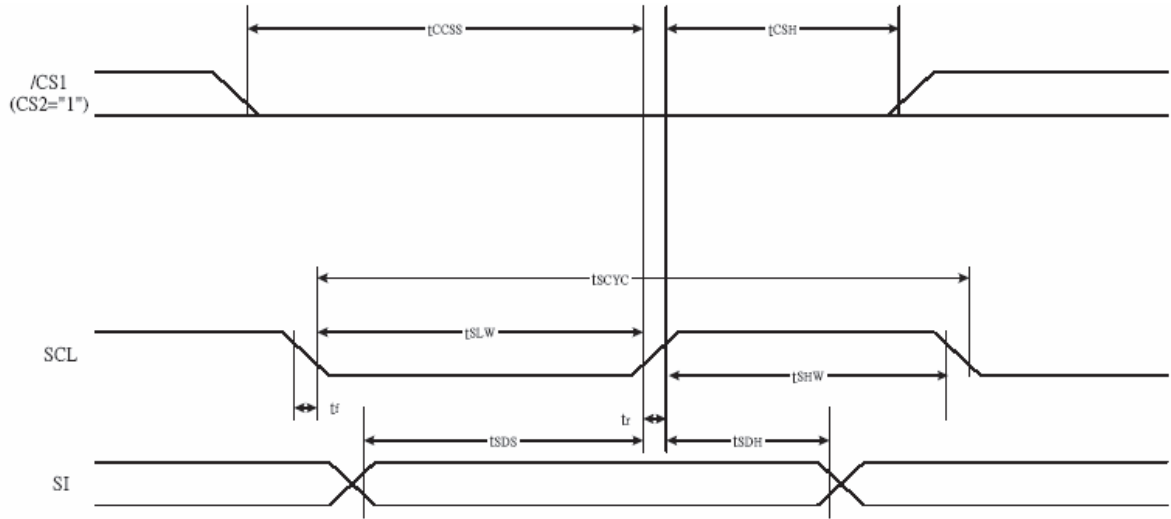

(V_{DD}=3.3V, Ta=-30~85°C)

Item	Signal	Symbol	Condition	Rating		Units
				Min.	Max.	
Serial Clock Period	SCL	tSCYC		50	—	ns
SCL "H" pulse width		tSHW		25	—	
SCL "L" pulse width		tSLW		25	—	
Data setup time	SI	tSDS		20	—	
Data hold time		tSDH		10	—	
CS-SCL time	CSB	tCSS		20	—	
CS-SCL time		tCSH		40	—	

4.4.5 SERIAL INTERFACE(IIC Interface)

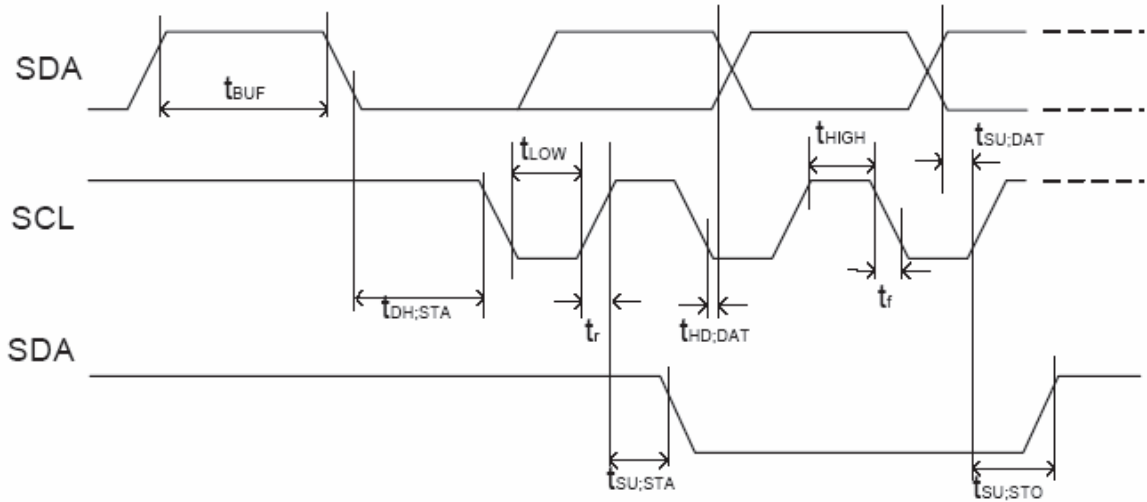

($V_{DD}=3.3V, T_a=-30\sim 85^{\circ}C$)

Item	Signal	Symbol	Condition	Rating		Units
				Min.	Max.	
SCL clock frequency	SCL	FSCLK		-	400	kHZ
SCL clock low period	SCL	TLOW		1.3	-	us
SCL clock high period	SCL	THIGH		0.6	-	us
Data set-up time	SI	TSU;Data		100	-	ns
Data hold time	SI	THD;Data		0	0.9	us
SCL,SDA rise time	SCL	TR		$20+0.1C_b$	300	ns
SCL,SDA fall time	SCL	TF		$20+0.1C_b$	300	ns
Capacitive load represented by each bus line		C_b		-	400	pF
Setup time for a repeated START condition	SI	TSU;SUA		0.6	-	us
Start condition hold time	SI	THD;STA		0.6	-	us
Setup time for STOP ondition		TSU;STO		0.6	-	us
Tolerable spike width on bus		TSW		-	50	ns
BUS free time between a STOP and START condition	SCL	TBUF		1.3		us

5 Programming

5.1 Instruction Table:

Instruction	A0	RW	DB7	DB6	DB5	DB4	DB3	DB2	DB1	DB0	Description
EXT=0 or 1											
Mode Set	0	0	0	0	1	1	1	0	0	0	2-byte instruction to set Mode and FR(Frame frequency control) BE(Booster efficiency control)
	0	0	FR3	FR2	FR1	FR0	0	BE	x'	EXT	
EXT=0											
Read display data	1	1	Read data							Read data into DDRAM	
Write display data	1	0	Write data							Write data into DDRAM	
Read status	0	1	BUSY	ON	RES	MF2	MF1	MF0	DS1	DS0	Read the internal status
ICON control register ON/OFF	0	0	1	0	1	0	0	0	1	ICON	ICON=0: ICON disable(default) ICON=1: ICON enable & set the page address to 16
Set page address	0	0	1	0	1	1	P3	P2	P1	P0	Set page address
Set column address MSB	0	0	0	0	0	1	Y9	Y8	Y7	Y6	Set column address MSB
Set column address LSB	0	0	0	0	0	0	Y5	Y4	Y3	Y2	Set column address LSB
Set modify-read	0	0	1	1	1	0	0	0	0	0	Set modify-read mode
Reset modify-read	0	0	1	1	1	0	1	1	1	0	release modify-read mode
Display ON/OFF	0	0	1	0	1	0	1	1	1	D	D=0: Display OFF D=1: Display ON
Set initial display line register	0	0	0	1	0	0	0	0	x'	x'	2-byte instruction to specify the initial display line to realize vertical scrolling
	0	0	x'	S6	S5	S4	S3	S2	S1	S0	
Set initial COM0 register	0	0	0	1	0	0	0	1	x'	x'	2-byte instruction to specify the initial COM0 to realize window scrolling
	0	0	x'	C6	C5	C4	C3	C2	C1	C0	
Select partial display line	0	0	0	1	0	0	1	0	x'	x'	2-byte instruction to set partial display duty ratio
	0	0	D7	D6	D5	D4	D3	D2	D1	D0	
Set N-line inversion	0	0	0	1	0	0	1	1	x'	x'	2-byte instruction to set N-line inversion register
	0	0	x'	x'	x'	N4	N3	N2	N1	N0	
Release N-line inversion	0	0	1	1	1	0	0	1	0	0	Release N-line inversion mode
Reverse display ON/OFF	0	0	1	0	1	0	0	1	1	REV	REV=0: normal display REV=1: reverse display
Entire display ON/OFF	0	0	1	0	1	0	0	1	0	EON	EON=0: normal display EON=1: entire display ON

Instruction	A0	RW	DB7	DB6	DB5	DB4	DB3	DB2	DB1	DB0	Description
Ext=0											
Power control	0	0	0	0	1	0	1	VC	VR	VF	Control power circuit operation
Select DC-DC step-up	0	0	0	1	1	0	0	1	DC1	DC0	Select the step-up of internal voltage converter
Select regulator register	0	0	0	0	1	0	0	R2	R1	R0	Select the internal resistance ratio of the regulator resistor
Select electronic volumn register	0	0	1	0	0	0	0	0	0	1	2-byte instruction to specify the reference voltage
	0	0	x'	x'	EV5	EV4	EV3	EV2	EV1	EV0	
Select LCD bias	0	0	0	1	0	1	0	B2	B1	B0	Select LCD bias
Set Bias Power Save Mode	0	0	1	1	1	1	0	0	1	1	Bias Power save Save the Bias current consumption
	0	0	0	0	0	0	0	0	0	0	
Release Bias Power Save Mode	0	0	1	1	1	1	0	0	1	1	Bias Power save release set the Bias power to normal
	0	0	0	0	0	0	0	1	0	0	
SHL select	0	0	1	1	0	0	SHL	x'	x'	x'	COM bi-direction selection SHL=0: normal direction SHL=1: reverse direction
ADC select	0	0	1	0	1	0	0	0	0	ADC	SEG bi-direction selection ADC=0: normal direction ADC=1: reverse direction
Oscillator on start	0	0	1	0	1	0	1	0	1	1	Start the built-in oscillator
Set power save mode	0	0	1	0	1	0	1	0	0	P	P=0: normal mode P=1: sleep mode
Release power save mode	0	0	1	1	1	0	0	0	0	1	release power save mode
Reset	0	0	1	1	1	0	0	0	1	0	initial the internal function
Set data direction & display data length(DDL)	x'	x'	1	1	1	0	1	0	0	0	2-byte instruction to specify the number of data bytes. (SPI mode)
	x'	x'	D7	D6	D5	D4	D3	D2	D1	D0	
Select FRC and PWM mode	0	0	1	0	0	1	0	FRC	PWM1	PWM0	FRC(1:3FRC, 0:4FRC) PWM1 PWM0 0 0 45PWM 0 1 45 PWM 1 0 60PWM 1 1 ---
NOP	0	0	1	1	1	0	0	0	1	1	<u>No operation</u>
Test Instruction	0	0	1	1	1	1	x'	x'	x'	x'	<u>Don't use this instruction</u>

Instruction	A0	RW	DB7	DB6	DB5	DB4	DB3	DB2	DB1	DB0	Description
EXT=1											
Set white mode and 1 st frame, set pulse width	0	0	1	0	0	0	0	0	0	0	Set white mode and 1st frame
	0	0	X'	X'	GA05	GA04	GA03	GA02	GA01	GA00	
Set white mode and 2 nd frame, set pulse width	0	0	1	0	0	0	0	0	0	1	Set white mode and 2nd frame
	0	0	X'	X'	GA05	GA04	GA03	GA02	GA01	GA00	
Set white mode and 3 rd frame, set pulse width	0	0	1	0	0	0	0	0	1	0	Set white mode and 3rd frame
	0	0	X'	X'	GA05	GA04	GA03	GA02	GA01	GA00	
Set white mode and 4 th frame, set pulse width	0	0	1	0	0	0	0	0	1	1	Set white mode and 4th frame
	0	0	X'	X'	GA05	GA04	GA03	GA02	GA01	GA00	
Set gray level 1 mode	0	0	84H~87H (4 bytes)								Set gray level1
Set gray level 2 mode	0	0	88H~8BH (4 bytes)								Set gray level2
Set gray level 3 mode	0	0	8CH~8FH (4bytes)								Set gray level3
Set gray level 4 mode	0	0	90H~93H (4bytes)								Set gray level4
Set gray level 5 mode	0	0	94H~97H (4bytes)								Set gray level5
Set gray level 6 mode	0	0	98H~9BH (4 bytes)								Set gray level6
Set gray level 7 mode	0	0	9CH~9FH (4 bytes)								Set gray level7
Set gray level 8 mode	0	0	A0H~A3H (4 bytes)								Set gray level8
Set gray level 9 mode	0	0	A4H~A7H (4 bytes)								Set gray level9
Set gray level 10 mode	0	0	A8H~ABH (4 bytes)								Set gray level10
Set gray level 11mode	0	0	ACH~AFH (4 bytes)								Set gray level11
Set gray level 12 mode	0	0	B0H~B3H (4 bytes)								Set gray level12
Set gray level 13 mode	0	0	B4H~B7H (4 bytes)								Set gray level13
Set gray level 14 mode	0	0	B8H~BBH (4 bytes)								Set gray level14
Set Dark mode and 1st frame, set pulse width	0	0	1	0	1	1	1	1	0	0	Set Dark mode and 1st frame, set pulse width
	0	0	X'	X'	GAF5	GAF4	GAF3	GAF2	GAF1	GAF0	
Set Dark mode and 2nd frame, set pulse width	0	0	1	0	1	1	1	1	0	1	Set Dark mode and 2nd frame, set pulse width
	0	0	X'	X'	GAF5	GAF4	GAF3	GAF2	GAF1	GAF0	
Set Dark mode and 3rd frame, set pulse width	0	0	1	0	1	1	1	1	1	0	Set Dark mode and 3rd frame, set pulse width
	0	0	X'	X'	GAF5	GAF4	GAF3	GAF2	GAF1	GAF0	
Set Dark mode and 4th frame, set pulse width	0	0	1	0	1	1	1	1	1	1	Set Dark mode and 4th frame, set pulse width
	0	0	X'	X'	GAF5	GAF4	GAF3	GAF2	GAF1	GAF0	

Appendix

1 Packing Method (TBD)

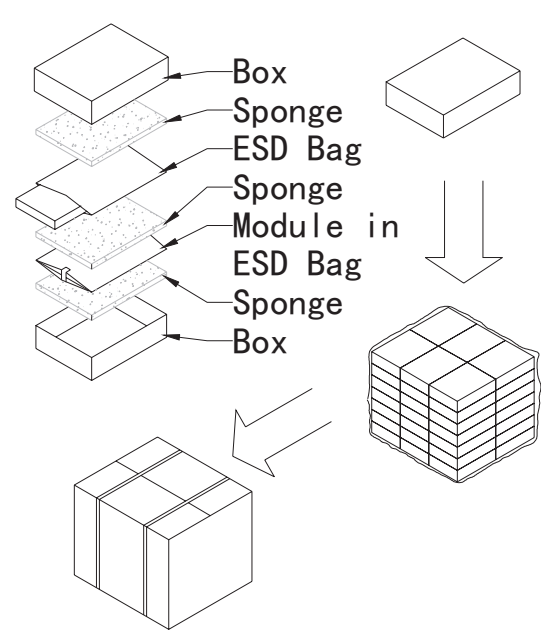
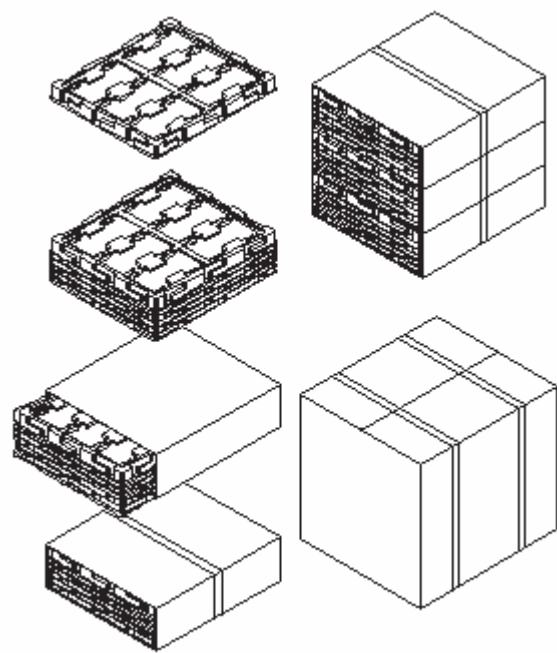
<p><input type="checkbox"/> Method 1</p> <p>ESD Bag + Product Box + Plastic Bag + Carton</p> <p>1. Quantity</p> <table border="1" style="width: 100%; border-collapse: collapse;"> <thead> <tr> <th style="width: 60%;">QUANTITY</th> <th>UNIT</th> </tr> </thead> <tbody> <tr> <td> </td> <td>PCS / ESD Bag</td> </tr> <tr> <td> </td> <td>PCS / Box</td> </tr> <tr> <td> </td> <td>Box / Carton</td> </tr> <tr> <td> </td> <td>PCS / Carton</td> </tr> </tbody> </table> <p>2. Material</p> <table border="1" style="width: 100%; border-collapse: collapse;"> <thead> <tr> <th style="width: 60%;">Material</th> <th>Size (LXWXH) mm</th> </tr> </thead> <tbody> <tr> <td>ESD Bag</td> <td> </td> </tr> <tr> <td>Product Box</td> <td> </td> </tr> <tr> <td>Carton</td> <td> </td> </tr> </tbody> </table> <p>3. Label</p> <div style="border: 1px solid black; padding: 5px; min-height: 80px;"> <p>PRODUCT ID: PART NO: QUANTITY: GROSS WEIGHT: MEASUREMENTS:</p> </div>	QUANTITY	UNIT		PCS / ESD Bag		PCS / Box		Box / Carton		PCS / Carton	Material	Size (LXWXH) mm	ESD Bag		Product Box		Carton		<p>4. Packing Method</p>  <p>Note: see table 1. Quantity for detail.</p>
QUANTITY	UNIT																		
	PCS / ESD Bag																		
	PCS / Box																		
	Box / Carton																		
	PCS / Carton																		
Material	Size (LXWXH) mm																		
ESD Bag																			
Product Box																			
Carton																			
<p><input checked="" type="checkbox"/> Method 2</p> <p>ESD Tray + Plastic Bag + Carton</p> <p>1. Quantity</p> <table border="1" style="width: 100%; border-collapse: collapse;"> <thead> <tr> <th style="width: 60%;">QUANTITY</th> <th>UNIT</th> </tr> </thead> <tbody> <tr> <td> </td> <td>PCS / Tray</td> </tr> <tr> <td> </td> <td>Tray / Carton</td> </tr> <tr> <td> </td> <td>PCS / Carton</td> </tr> </tbody> </table> <p>2. Material</p> <table border="1" style="width: 100%; border-collapse: collapse;"> <thead> <tr> <th style="width: 60%;">Material</th> <th>Size (LXWXH) mm</th> </tr> </thead> <tbody> <tr> <td>ESD Tray</td> <td> </td> </tr> <tr> <td>Carton</td> <td> </td> </tr> </tbody> </table> <p>3. Label</p> <div style="border: 1px solid black; padding: 5px; min-height: 80px;"> <p>PRODUCT ID: PART NO: QUANTITY: GROSS WEIGHT: MEASUREMENTS:</p> </div>	QUANTITY	UNIT		PCS / Tray		Tray / Carton		PCS / Carton	Material	Size (LXWXH) mm	ESD Tray		Carton		<p>4. Packing Method</p>  <p>Note: see table 1. Quantity for detail.</p>				
QUANTITY	UNIT																		
	PCS / Tray																		
	Tray / Carton																		
	PCS / Carton																		
Material	Size (LXWXH) mm																		
ESD Tray																			
Carton																			

Note:

2 Definitions of Optical Characteristic

2.1 Contrast Ratio Test

A) Contrast ratio is calculated by the following formula when the output voltage is obtained from the electro-optical test system.

B) Test Condition: Accord to the LCD's driving method and operating voltage (V_{LCD}).

C) Formula:

$$\text{Contrast Ratio (Positive type)} = \frac{\text{Photometer output voltage when non-select waveform is applying}}{\text{Photometer output voltage when select waveform is applying}}$$

$$\text{Contrast Ratio (Negative type)} = \frac{\text{Photometer output voltage when select waveform is applying}}{\text{Photometer output voltage when non-select waveform is applying}}$$

D) Test system:

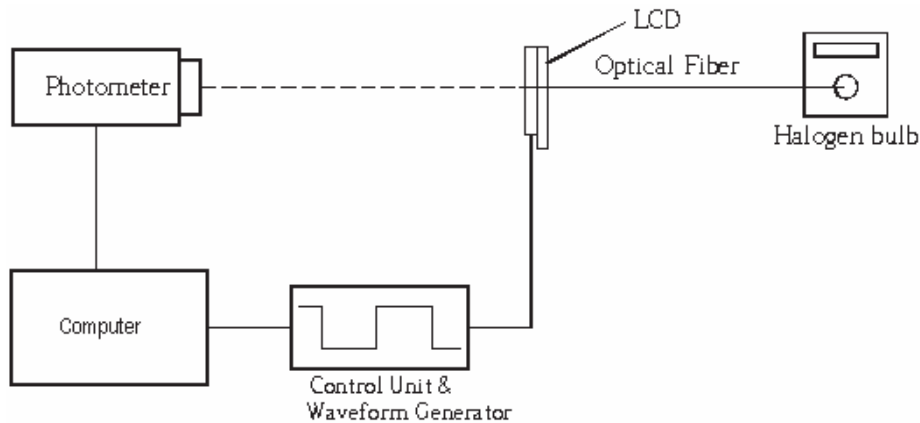

2.2 Response time

2.2.1 Positive type

- A) Rise time is defined as the time required for the transmission to change from 90% to 10%.
- B) Fall time is defined as the time required for the transmission to change from 10% to 90%.
- C) On time is defined as the time required for the transmission to change from 100% to 10%.
- D) Off time is defined as the time required for the transmission to change from 0% to 90%.

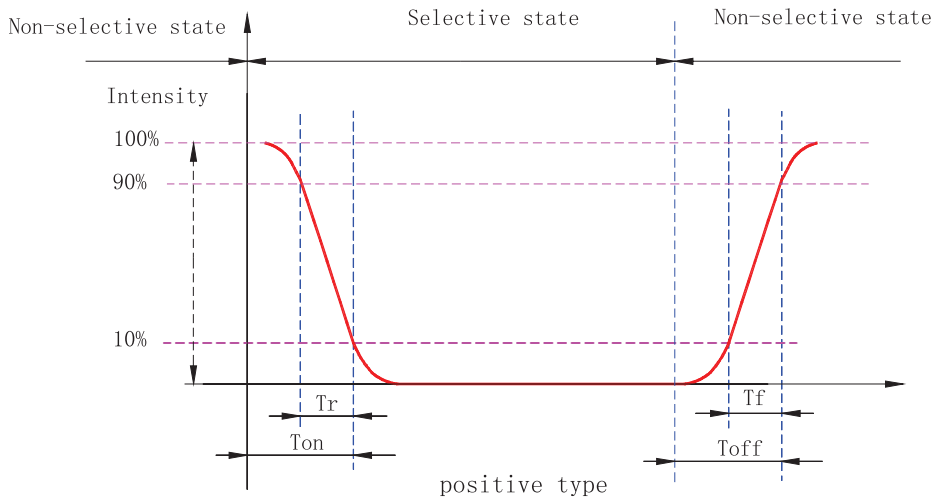

2.2.2 Negative type

- A) Rise time is defined as the time required for the transmission to change from 10% to 90%.
- B) Fall time is defined as the time required for the transmission to change from 90% to 10%.
- C) On time is defined as the time required for the transmission to change from 0% to 90%.
- D) Off time is defined as the time required for the transmission to change from 100% to 10%.

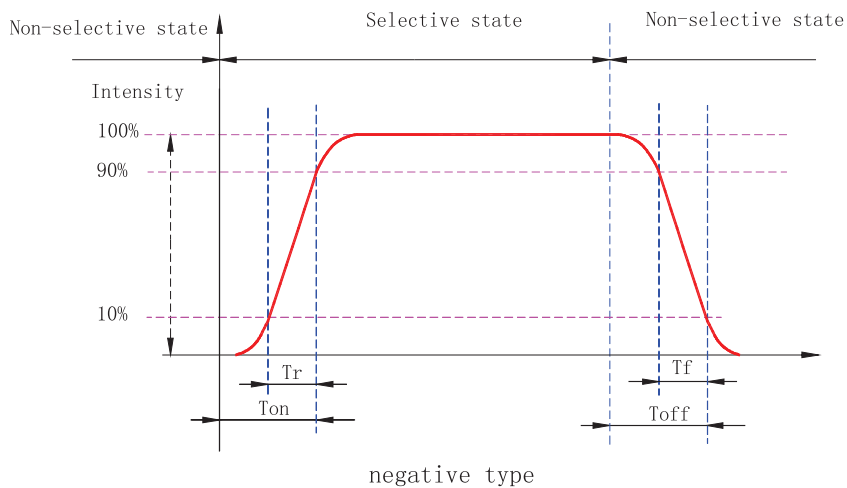

2.3 Viewing Angle

A) Viewing angle is definition

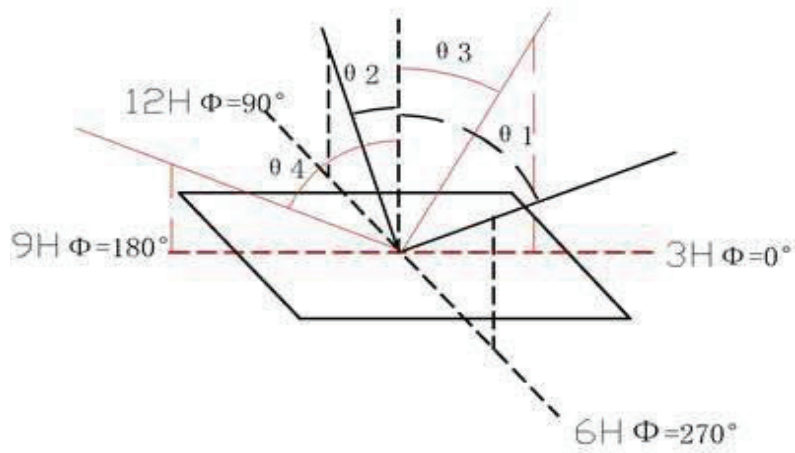

B) System Block Diagram

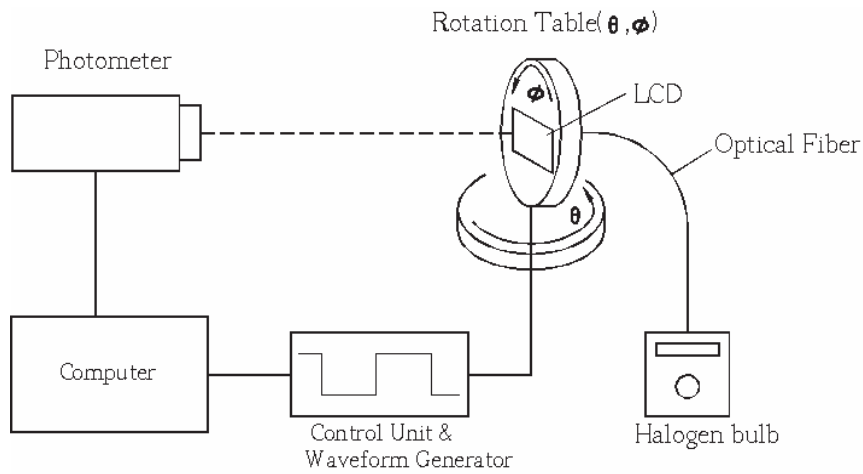

3 Quality Units

3.1 Visual and Technological Inspection

- Inspection direction should be perpendicular to LCD surface;
- Inspection should be performed under the condition of 20~40W fluorescent lamp;
- The distance between inspector's eyes & product surface should be 30cm~50cm when inspection.

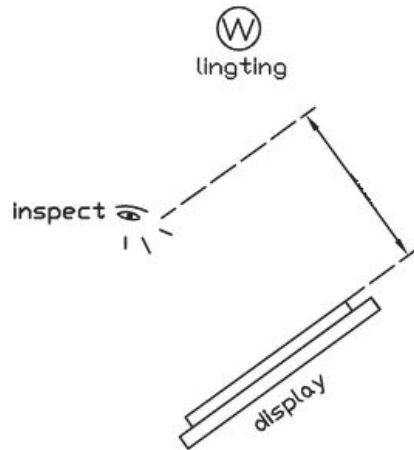

Definition of LCD area

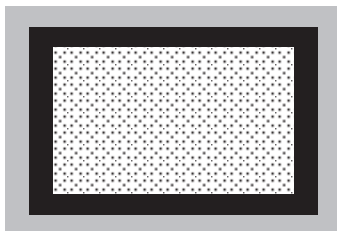

A: Active Area



B: Viewing Area



C: Invisible Area (It is invisible after assembly; any defects in this area should be ignored.)

3.2 Sampling Plan

3.2.1 Sampling Method

According to GB2828.1-2003 (Equivalent to MIL-STD-105/E) General inspection level II.

3.2.2 AQL Definition

Major: AQL=0.65 (Please refer to the definition in "5. Inspection Criteria")

Minor: AQL=1.0 (Please refer to the definition in "5. Inspection Criteria")

4 Inspection Criteria

4.1 Appearance Criteria (Not energized)

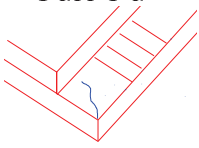
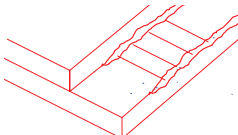
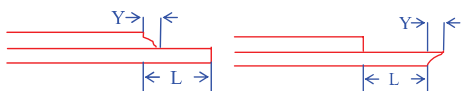
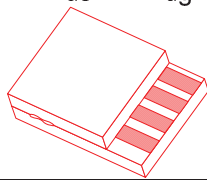
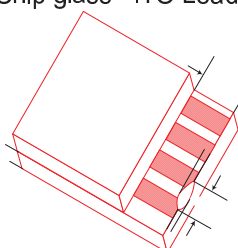
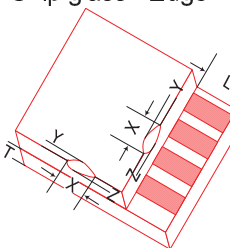
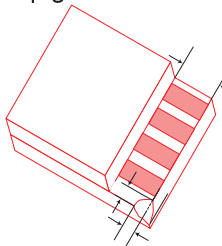
NO.	Defect Name & Illustration	Criteria	Class																
4.1.1	Light Leakage	Not allowed	Major																
4.1.2	Vacuum Bubble	Not allowed	Major																
4.1.3	Rainbow	According to Limit Sample	Minor																
4.1.4	Glass Crack 	Not allowed	Minor																
4.1.5	Protrusion - ITO lead 	 $Y \leq L/4$, allowed quantity:2	Minor																
4.1.6	Protrusion - Edge 	Allowed if protrusion didn't affect dimension.	Minor																
4.1.7	Chip glass - ITO Lead 	Unit: mm <table border="1"> <thead> <tr> <th>X</th> <th>Y</th> <th>Z</th> <th>Allowed Qty.</th> </tr> </thead> <tbody> <tr> <td>Random</td> <td>≤ 0.5, if $L/3 > 0.5$</td> <td>$\leq T/2$</td> <td>NC¹</td> </tr> <tr> <td>≤ 4.0</td> <td>$\leq L/3$</td> <td>$\leq T$</td> <td>3</td> </tr> </tbody> </table>	X	Y	Z	Allowed Qty.	Random	≤ 0.5 , if $L/3 > 0.5$	$\leq T/2$	NC ¹	≤ 4.0	$\leq L/3$	$\leq T$	3	Minor				
X	Y	Z	Allowed Qty.																
Random	≤ 0.5 , if $L/3 > 0.5$	$\leq T/2$	NC ¹																
≤ 4.0	$\leq L/3$	$\leq T$	3																
4.1.8	Chip glass - Edge 	Unit: mm <table border="1"> <thead> <tr> <th>X</th> <th>Y*</th> <th>Z</th> <th>Allowed Qty.</th> </tr> </thead> <tbody> <tr> <td>Random</td> <td>≤ 1.5, if $L/3 > 1.5$</td> <td>$\leq T/2$</td> <td>NC</td> </tr> <tr> <td>≤ 5.0</td> <td>≤ 1.5</td> <td>$\leq T$</td> <td>3</td> </tr> <tr> <td>Random</td> <td>≤ 0.5</td> <td>$\leq T/2$</td> <td>NC</td> </tr> </tbody> </table> Remark: Y didn't reach A area & 1/3 seal line.	X	Y*	Z	Allowed Qty.	Random	≤ 1.5 , if $L/3 > 1.5$	$\leq T/2$	NC	≤ 5.0	≤ 1.5	$\leq T$	3	Random	≤ 0.5	$\leq T/2$	NC	Minor
X	Y*	Z	Allowed Qty.																
Random	≤ 1.5 , if $L/3 > 1.5$	$\leq T/2$	NC																
≤ 5.0	≤ 1.5	$\leq T$	3																
Random	≤ 0.5	$\leq T/2$	NC																
4.1.9	Chip glass - Corner 	Unit: mm <table border="1"> <thead> <tr> <th>X</th> <th>Y</th> <th>Z</th> <th>Allowed Qty.</th> </tr> </thead> <tbody> <tr> <td>≤ 4</td> <td>$\leq L$</td> <td>$\leq T$</td> <td>2</td> </tr> </tbody> </table> Remark: If X reach ITO lead, according to the criteria of "4.1.7".	X	Y	Z	Allowed Qty.	≤ 4	$\leq L$	$\leq T$	2	Minor								
X	Y	Z	Allowed Qty.																
≤ 4	$\leq L$	$\leq T$	2																

¹ NC = Not Count

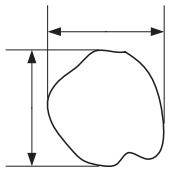
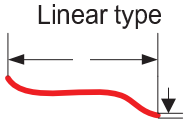
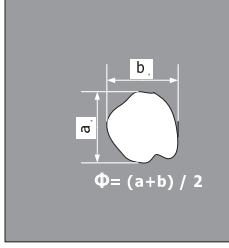
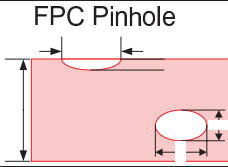
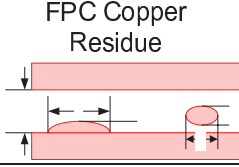
4.1.10	<p>Circular type</p> 	Suppose S^2 = The area of A, the criteria in A&B is as below,					Minor																												
		<table border="1"> <tr> <th>S (cm²) \ Φ (mm)</th> <th>$S \leq 4$</th> <th>$4 < S \leq 12$</th> <th>$12 < S \leq 50$</th> <th>$50 < S \leq 150$</th> <th>$S > 150$</th> </tr> <tr> <td>$\Phi \leq 0.10$</td> <td>NC</td> <td>NC</td> <td>NC</td> <td>NC</td> <td>NC</td> </tr> <tr> <td>$0.10 < \Phi \leq 0.20$</td> <td>1</td> <td>2</td> <td>2</td> <td>3</td> <td>3</td> </tr> <tr> <td>$0.20 < \Phi \leq 0.30$</td> <td>1</td> <td>1</td> <td>2</td> <td>2</td> <td>3</td> </tr> <tr> <td>$\Phi > 0.30$</td> <td>0</td> <td>0</td> <td>0</td> <td>0</td> <td>0</td> </tr> </table>	S (cm ²) \ Φ (mm)	$S \leq 4$	$4 < S \leq 12$	$12 < S \leq 50$		$50 < S \leq 150$	$S > 150$	$\Phi \leq 0.10$	NC	NC	NC	NC	NC	$0.10 < \Phi \leq 0.20$	1	2	2	3	3	$0.20 < \Phi \leq 0.30$	1	1	2	2	3	$\Phi > 0.30$	0	0	0	0	0	<p>Remark: Bubble, dirt spot, concavo-convex spot & stab spot should be regarded as circular defect. Maximum defect number in 1cm² is 1. Please refer to footmark for the conversion between S & Diagonal.</p>	
S (cm ²) \ Φ (mm)	$S \leq 4$	$4 < S \leq 12$	$12 < S \leq 50$	$50 < S \leq 150$	$S > 150$																														
$\Phi \leq 0.10$	NC	NC	NC	NC	NC																														
$0.10 < \Phi \leq 0.20$	1	2	2	3	3																														
$0.20 < \Phi \leq 0.30$	1	1	2	2	3																														
$\Phi > 0.30$	0	0	0	0	0																														
4.1.11	<p>Linear type</p> 	Suppose S = The area of A, the criteria in A&B is as below,					Minor																												
		<table border="1"> <tr> <th>S (cm²) \ a&b (mm)</th> <th>$S \leq 4$</th> <th>$4 < S \leq 12$</th> <th>$12 < S \leq 50$</th> <th>$50 < S \leq 150$</th> <th>$S > 150$</th> </tr> <tr> <td>$a \leq 0.03$</td> <td>NC</td> <td>NC</td> <td>NC</td> <td>NC</td> <td>NC</td> </tr> <tr> <td>$0.03 < a \leq 0.05$, $b \leq 3$</td> <td>2</td> <td>3</td> <td>4</td> <td>5</td> <td>6</td> </tr> <tr> <td>$a > 0.05$</td> <td colspan="5">According to the criteria of <4.1.10></td> </tr> </table>	S (cm ²) \ a&b (mm)	$S \leq 4$	$4 < S \leq 12$	$12 < S \leq 50$		$50 < S \leq 150$	$S > 150$	$a \leq 0.03$	NC	NC	NC	NC	NC	$0.03 < a \leq 0.05$, $b \leq 3$	2	3	4	5	6	$a > 0.05$	According to the criteria of <4.1.10>					<p>Remark: Linear scratch, dirt line should be regarded as linear defect. Maximum defect number in 1cm² is 1.</p>							
S (cm ²) \ a&b (mm)	$S \leq 4$	$4 < S \leq 12$	$12 < S \leq 50$	$50 < S \leq 150$	$S > 150$																														
$a \leq 0.03$	NC	NC	NC	NC	NC																														
$0.03 < a \leq 0.05$, $b \leq 3$	2	3	4	5	6																														
$a > 0.05$	According to the criteria of <4.1.10>																																		
4.1.12	<p>Polar bubble / Dent</p> 	Suppose S = The area of A, the criteria in A&B is as below,					Minor																												
		<table border="1"> <tr> <th>S (cm²) \ Φ (mm)</th> <th>$S \leq 4$</th> <th>$4 < S \leq 12$</th> <th>$12 < S \leq 50$</th> <th>$50 < S \leq 150$</th> <th>$S > 150$</th> </tr> <tr> <td>$\Phi \leq 0.15$</td> <td>NC</td> <td>NC</td> <td>NC</td> <td>NC</td> <td>NC</td> </tr> <tr> <td>$0.15 < \Phi \leq 0.25$</td> <td>1</td> <td>2</td> <td>2</td> <td>3</td> <td>3</td> </tr> <tr> <td>$0.25 < \Phi \leq 0.35$</td> <td>1</td> <td>1</td> <td>2</td> <td>2</td> <td>3</td> </tr> <tr> <td>$\Phi > 0.35$</td> <td>0</td> <td>0</td> <td>0</td> <td>0</td> <td>0</td> </tr> </table>	S (cm ²) \ Φ (mm)	$S \leq 4$	$4 < S \leq 12$	$12 < S \leq 50$		$50 < S \leq 150$	$S > 150$	$\Phi \leq 0.15$	NC	NC	NC	NC	NC	$0.15 < \Phi \leq 0.25$	1	2	2	3	3	$0.25 < \Phi \leq 0.35$	1	1	2	2	3	$\Phi > 0.35$	0	0	0	0	0	<p>Remark: Maximum defect number in 1cm² is 1.</p>	
S (cm ²) \ Φ (mm)	$S \leq 4$	$4 < S \leq 12$	$12 < S \leq 50$	$50 < S \leq 150$	$S > 150$																														
$\Phi \leq 0.15$	NC	NC	NC	NC	NC																														
$0.15 < \Phi \leq 0.25$	1	2	2	3	3																														
$0.25 < \Phi \leq 0.35$	1	1	2	2	3																														
$\Phi > 0.35$	0	0	0	0	0																														
4.1.13	Polarizer Stab	According to the criteria of <5.1.10>					Minor																												
4.1.14	Polarizer Scratch	According to the criteria of <5.1.11>					Minor																												
4.1.15	<p>FPC Pinhole</p> 	<table border="1"> <tr> <th>a</th> <th>b</th> <th>Allowed Qty.</th> </tr> <tr> <td>$\leq W/3$</td> <td>$\leq W$</td> <td>NC</td> </tr> <tr> <td>$> W/3$</td> <td>$> W$</td> <td>Not allowed</td> </tr> </table>	a	b	Allowed Qty.	$\leq W/3$	$\leq W$	NC	$> W/3$	$> W$	Not allowed					Minor																			
		a	b	Allowed Qty.																															
$\leq W/3$	$\leq W$	NC																																	
$> W/3$	$> W$	Not allowed																																	
<table border="1"> <tr> <th>a</th> <th>b</th> <th>Allowed Qty.</th> </tr> <tr> <td>$\leq W/3$</td> <td>$\leq W$</td> <td>NC</td> </tr> <tr> <td>$> W/3$</td> <td>$> W$</td> <td>Not allowed</td> </tr> </table>	a	b	Allowed Qty.	$\leq W/3$	$\leq W$	NC	$> W/3$	$> W$	Not allowed																										
a	b	Allowed Qty.																																	
$\leq W/3$	$\leq W$	NC																																	
$> W/3$	$> W$	Not allowed																																	
4.1.16	<p>FPC Copper Residue</p> 	<table border="1"> <tr> <th>a</th> <th>b</th> <th>Allowed Qty.</th> </tr> <tr> <td>$\leq W/3$</td> <td>$\leq W$</td> <td>NC</td> </tr> <tr> <td>$> W/3$</td> <td>$> W$</td> <td>Not allowed</td> </tr> </table>	a	b	Allowed Qty.	$\leq W/3$	$\leq W$	NC	$> W/3$	$> W$	Not allowed					Minor																			
		a	b	Allowed Qty.																															
$\leq W/3$	$\leq W$	NC																																	
$> W/3$	$> W$	Not allowed																																	
<table border="1"> <tr> <th>a</th> <th>b</th> <th>Allowed Qty.</th> </tr> <tr> <td>$\leq W/3$</td> <td>$\leq W$</td> <td>NC</td> </tr> <tr> <td>$> W/3$</td> <td>$> W$</td> <td>Not allowed</td> </tr> </table>	a	b	Allowed Qty.	$\leq W/3$	$\leq W$	NC	$> W/3$	$> W$	Not allowed																										
a	b	Allowed Qty.																																	
$\leq W/3$	$\leq W$	NC																																	
$> W/3$	$> W$	Not allowed																																	
4.1.17	<p>FPC Impress / Crease</p>	<table border="1"> <tr> <th>Shape</th> <th>Allowed Qty.</th> </tr> <tr> <td>Moulage / Impress</td> <td>NC</td> </tr> <tr> <td>Crease with a sharp angle</td> <td>Not allowed</td> </tr> </table>	Shape	Allowed Qty.	Moulage / Impress	NC	Crease with a sharp angle	Not allowed					Minor																						
		Shape	Allowed Qty.																																
		Moulage / Impress	NC																																
Crease with a sharp angle	Not allowed																																		

² Suppose Length:Width = 4:3, The conversion between S & diagonal length is as below table,

S (cm ²)	Diagonal Length (Inch)
4	1.13
12	1.95
50	3.99
150	6.91

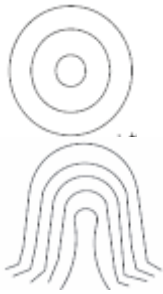
4.1.18	Soldering defect	According to the criteria of IPC-A-610C	Minor
4.1.19	TP ³ : black/white spot	According to the criteria of <4.1.10>	Minor
4.1.20	TP: Dent	According to the criteria of <4.1.12>	Minor
4.1.21	TP: Scratch	According to the criteria of <4.1.11>	Minor
4.1.22	TP: Newton Ring 	13.1 Regular shape Newton ring area \leq 1/3 Total display area, Neglect. Newton ring area $>$ 1/3 Total display area, NG. 13.2 Irregular shape Newton ring area \leq 1/2 Total display area, Neglect. Newton ring area $>$ 1/2 Total display area, NG. Remark: If Newton ring caused pattern distortion, NG.	Minor

4.2 Defect when display (Energized)

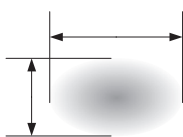
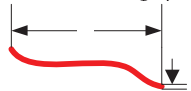
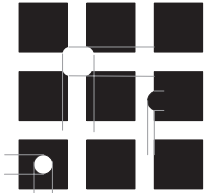
NO.	Defect Name & Illustration	Criteria	Class																														
4.2.1	Circular type when display (Not change along with voltage)	According to the criteria of <4.1.10>	Minor																														
4.2.2	Circular type when display (Change along with voltage) 	Suppose S= The area of A, the criteria in A&B is as below, <table border="1"> <thead> <tr> <th>S (cm²) \ Φ (mm)</th> <th>S\leq4</th> <th>4<S\leq12</th> <th>12<S\leq50</th> <th>50<S\leq150</th> <th>S>150</th> </tr> </thead> <tbody> <tr> <td>$\Phi \leq 0.30$</td> <td>NC</td> <td>NC</td> <td>NC</td> <td>NC</td> <td>NC</td> </tr> <tr> <td>0.30<$\Phi \leq 0.50$</td> <td>1</td> <td>2</td> <td>2</td> <td>3</td> <td>3</td> </tr> <tr> <td>0.50<$\Phi \leq 0.80$</td> <td>1</td> <td>1</td> <td>2</td> <td>2</td> <td>3</td> </tr> <tr> <td>$\Phi > 0.80$</td> <td>0</td> <td>0</td> <td>0</td> <td>0</td> <td>0</td> </tr> </tbody> </table> Remark: Maximum defect number in 1cm ² is 1.	S (cm ²) \ Φ (mm)	S \leq 4	4<S \leq 12	12<S \leq 50	50<S \leq 150	S>150	$\Phi \leq 0.30$	NC	NC	NC	NC	NC	0.30< $\Phi \leq 0.50$	1	2	2	3	3	0.50< $\Phi \leq 0.80$	1	1	2	2	3	$\Phi > 0.80$	0	0	0	0	0	Minor
S (cm ²) \ Φ (mm)	S \leq 4	4<S \leq 12	12<S \leq 50	50<S \leq 150	S>150																												
$\Phi \leq 0.30$	NC	NC	NC	NC	NC																												
0.30< $\Phi \leq 0.50$	1	2	2	3	3																												
0.50< $\Phi \leq 0.80$	1	1	2	2	3																												
$\Phi > 0.80$	0	0	0	0	0																												
4.2.3	Linear type when display (Not change along with voltage)	According to the criteria of <4.1.1>	Minor																														
4.2.4	Linear type when display (Change along with voltage) 	Suppose S= The area of A, the criteria in A&B is as below, <table border="1"> <thead> <tr> <th>S (cm²) \ a&b (mm)</th> <th>S\leq4</th> <th>4<S\leq12</th> <th>12<S\leq50</th> <th>50<S\leq150</th> <th>S>150</th> </tr> </thead> <tbody> <tr> <td>a\leq0.05</td> <td>NC</td> <td>NC</td> <td>NC</td> <td>NC</td> <td>NC</td> </tr> <tr> <td>0.05<a\leq0.10, b\leq5</td> <td>2</td> <td>3</td> <td>4</td> <td>5</td> <td>6</td> </tr> <tr> <td>a>0.10</td> <td colspan="5">According to the criteria of <4.2.2></td> </tr> </tbody> </table> Remark: Maximum defect number in 1cm ² is 1.	S (cm ²) \ a&b (mm)	S \leq 4	4<S \leq 12	12<S \leq 50	50<S \leq 150	S>150	a \leq 0.05	NC	NC	NC	NC	NC	0.05<a \leq 0.10, b \leq 5	2	3	4	5	6	a>0.10	According to the criteria of <4.2.2>					Minor						
S (cm ²) \ a&b (mm)	S \leq 4	4<S \leq 12	12<S \leq 50	50<S \leq 150	S>150																												
a \leq 0.05	NC	NC	NC	NC	NC																												
0.05<a \leq 0.10, b \leq 5	2	3	4	5	6																												
a>0.10	According to the criteria of <4.2.2>																																
4.2.5	Pinhole 	Suppose S= The area of A, the criteria in A&B is as below, <table border="1"> <thead> <tr> <th>S (cm²) \ Φ (mm)</th> <th>S\leq4</th> <th>4<S\leq12</th> <th>12<S\leq50</th> <th>50<S\leq150</th> <th>S>150</th> </tr> </thead> <tbody> <tr> <td>$\Phi \leq 0.10$</td> <td>NC</td> <td>NC</td> <td>NC</td> <td>NC</td> <td>NC</td> </tr> <tr> <td>0.10<$\Phi \leq 0.15$</td> <td>1</td> <td>2</td> <td>2</td> <td>3</td> <td>3</td> </tr> <tr> <td>0.15<$\Phi \leq 0.25$</td> <td>1</td> <td>1</td> <td>2</td> <td>2</td> <td>3</td> </tr> <tr> <td>$\Phi > 0.25$</td> <td>0</td> <td>0</td> <td>0</td> <td>0</td> <td>0</td> </tr> </tbody> </table> Remark: Maximum defect number in 1cm ² is 1.	S (cm ²) \ Φ (mm)	S \leq 4	4<S \leq 12	12<S \leq 50	50<S \leq 150	S>150	$\Phi \leq 0.10$	NC	NC	NC	NC	NC	0.10< $\Phi \leq 0.15$	1	2	2	3	3	0.15< $\Phi \leq 0.25$	1	1	2	2	3	$\Phi > 0.25$	0	0	0	0	0	Major
S (cm ²) \ Φ (mm)	S \leq 4	4<S \leq 12	12<S \leq 50	50<S \leq 150	S>150																												
$\Phi \leq 0.10$	NC	NC	NC	NC	NC																												
0.10< $\Phi \leq 0.15$	1	2	2	3	3																												
0.15< $\Phi \leq 0.25$	1	1	2	2	3																												
$\Phi > 0.25$	0	0	0	0	0																												

³ TP=Touch Panel

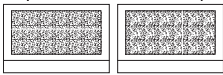
4.2.6	Segment Distortion	More than 1/5 size in spec is not allowed.	Major
4.2.7	Missing Segment (Row or column) 	Not allowed	Major
4.2.8	Abnormal Display	Not allowed	Major
4.2.9	Display inhomogeneity / CR inhomogeneity	According to the approved sample by both sides	Minor
4.2.10	Too much current	Not allowed	Major
4.2.11	No display	Not allowed	Major
4.2.12	No backlight / flicking	Not allowed	Major

5 Caution for using

- 5.1 Recommended storage condition: 50~60%RH, 25+/-5°C;
- 5.2 Avoid direct sunlight. Avoid operating or storage under the temperature which exceeds the standard for a long time;
- 5.3 Avoid driving LCD with DC (Direct Current);
- 5.4 LCD was made of glass, please avoid any impact or pressure on surface;
- 5.5 If the skin contact with liquid crystal incautiously, wash with water for more than 15 minutes. If you feel uncomfortable, please see the doctor immediately;
- 5.6 It is prohibited to clean polarizer by ethanol or acetone. Clean polarizer by pure water is recommended;
- 5.7 The products should be used within 6 month. Otherwise, the ITO pad and FPC pad maybe be oxidized and cause poor contact, etc.;
- 5.8 ESD: TFT module or COG module is sensitive to ESD, effective action should be taken before you touch the products;
- 5.9 Avoid contacting the ITO pad by hand and pressing the surface of the LCD. Please take the both sides when you fetch the LCD.

6 Reliability-TEST

6.1. Standard Specifications for Reliability

6.1-1 Test method

There should be no existing conspicuous failure of functions and appearance in LCD after the following tests.

NO	Item	Description
1	Low Temperature Operating	The sample should be allowed to stand at $(-20 \pm 2)^{\circ}\text{C}$ for 96 Hours under driving condition.
2	High Temperature Operating	The sample should be allowed to stand at $(+70 \pm 2)^{\circ}\text{C}$ for 96 Hours under driving condition.
3	Low Temperature Storage	The sample should be allowed to stand at $(-25 \pm 3)^{\circ}\text{C}$ for 96 Hours under no-load condition, and then returning it to normal temperature condition, and allowing it stand for 24 hours
4	High Temperature Storage	The sample should be allowed to stand at $(+75 \pm 2)^{\circ}\text{C}$ for 96Hours under no-load condition, and then returning it to normal temperature condition, and allowing it stand for 24 hours
5	Moisture resistance	The sample should be allowed to stand at $(40 \pm 2)^{\circ}\text{C}$, $(95 \pm 2)\% \text{RH}$ for 96Hours under no-load condition excluding the polarizer, then taking it out and drying it at normal temperature, and allowing it stand for 24 hours

Note:

T_{STL} : Lowest Storage Operation Temperature.

T_{STH} : Lowest Storage Temperature.

6.1-2 Testing Conditions and Inspection Criteria:

For the final test, the testing sample must be stored at room temperature for 24 hours, after the tests listed above; Standard specifications for Reliability have been executed in order to ensure stability.

NO	Item	Inspection Criteria
1	Current Consumption	The current consumption should be under double of initial test.
2	Contrast	The contrast must be larger than half of initial test.
3	Appearance	Appearance defects should not happen.

6.2 Life Time

Functions, performance, appearance, etc. shall be free from remarkable deterioration within 50,000 hours under ordinary operating and storage conditions room temperature $(25 \pm 10^{\circ}\text{C})$, normal humidity $(45 \pm 20\% \text{RH})$, and in area not exposed to direct sunlight.