

1.0 Introduction

The AMIS-50051 is a small digital demodulator, specially developed to work with the AMIS-50050 spread spectrum baseband controller. It simplifies the design of the receiver in a direct sequence spread spectrum wireless communication link.

2.0 Key Features

- 1Mbit/s demodulation (QPSK)
- PN code tracking output to AMIS-50050 (Please refer to the AMIS-50050 spread spectrum baseband controller.)
- Fully programmable
- CMOS technology
- Power-down mode

3.0 Applications

- Wireless local area networks
- Portable wireless communication
- Digital cellular telephones
- Wireless ISDN modems

The AMIS-50051 simplifies the design of the receiver in a direct sequence spread spectrum wireless communication link. The AMIS-50051 uses advanced DSP technology to demodulate the data from a BPSK/DBPSK/QPSK/DQPSK modulated signal. This technique also provides a PN code tracking signal output, a carrier tracking signal and an automatic gain control (AGC) output signal. The power of the AMIS-50051 reduces the complexity and component count of a DSSS receiver. The AMIS-50051 is designed to demodulate QPSK or BPSK data from a carrier whose frequency is 11MHz or less. Data rates can be as high as 1Mbit/s for QPSK signals or 500Kbit/s for BPSK signals. An error signal is produced, which can be used to acquire and track the PN code of a direct sequence spread spectrum system. This output is a voltage, which the AMIS-50050 (please refer to AMIS-50050 spread spectrum baseband controller) uses to change the phase of the receiver's PN code. An external despreading device is required to remove the PN code from the received signal. This reduces the chance of false acquisition over other methods. The AMIS-50051's internal NCO oscillator is adjusted by a signal produced from the data demodulation process. This is used to track variations in the carrier frequency of the received signal.

The AMIS-50051 produces a level error output. This output is pulsed high or low depending on the level of the received signal. This can be used to form an AGC circuit.

The AMIS-50051 requires few external components. The AMIS-50051 is designed to work directly with the AMIS-50050 to simplify the design effort of a wireless communication link.

4.0 AMIS-50051 Block Diagram

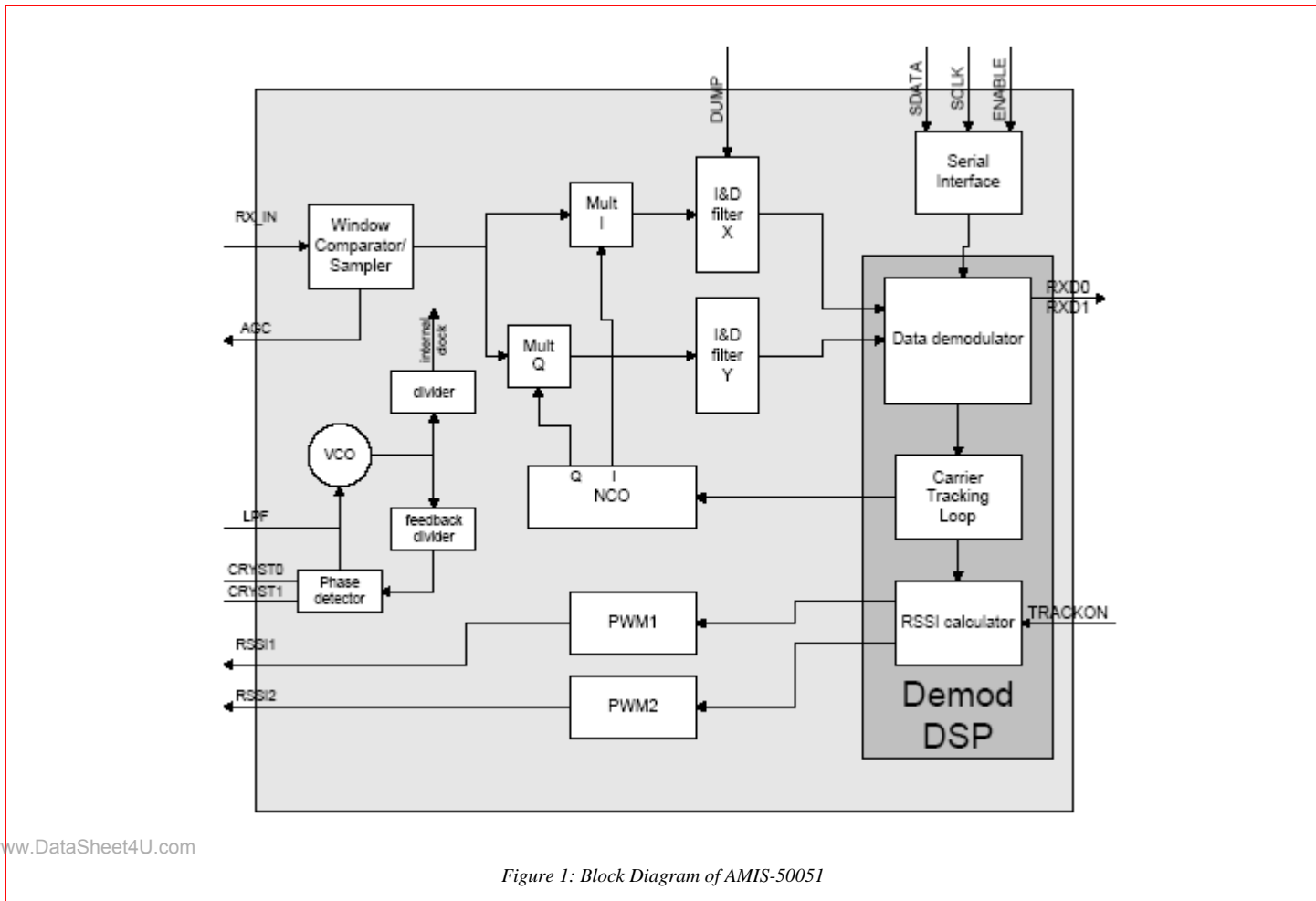

www.DataSheet4U.com

Figure 1: Block Diagram of AMIS-50051

5.0 Package Availability

- 24 pin SOIC
- 32 pin TQFP

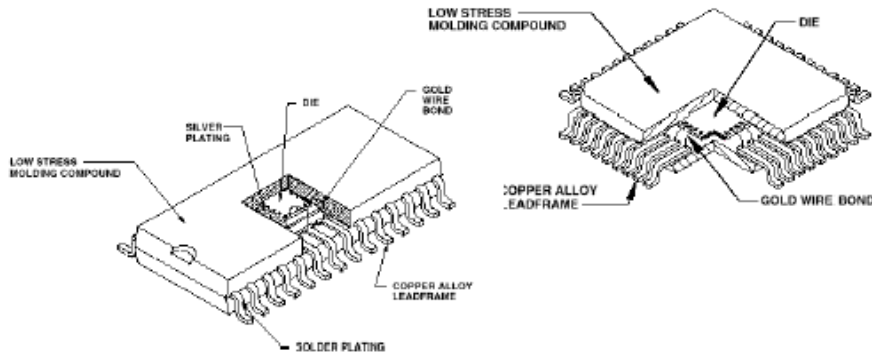

Figure 2: Package Availability

Table 1: Pin Descriptions

Pin Name	Number on 24 Pin SOIC	Number on 32 Pin TQFP	Functional Description	Type
DVDD	1,12	11, 30	Digital power	Power
DVSS	2,11	10, 31	Digital ground	Ground
SDATA	3	32,	Data for serial programming interface	Input
SCLK	4	1	Clock for serial programming interface, sensitive to rising edge	Output
RSSI2	5	2	RSSI 2 for AMIS-50050	Output
RSSI1	6	3	RSSI 1 for AMIS-50050	Output
RXD0	7	6	Received data Bit 0	Output
RXD1	8	7	Received data Bit 1	Output
TRACKON	9	8	Indicates that the AMIS-50050 is tracking the incoming signal, active high	Input
DUMP	10	9	Activate and dump control logic input	Input
LPF	15	16	PLL phase detector output, internal VCO output	Analog
CRYST1	16	17	Crystal oscillator or external reference input	Crystal OSC/Input
CRYST0	17	18	Crystal oscillator	Crystal OSC
EXT_IN	18	19	Used as digital input from external window comparator, test input not for normal use	Input
RES	19	22	Active low reset	Input
AGC	20	23	Automatic gain control	Output
RX_IN	21	24	IF signal input, can also be used as digital input from external window comparator	Analog/Input
ENABLE	24	27	Active low enable for serial programming interface	Input
AVDD	13,23	26	Analog power	Power
AVSS	14,22	25	Analog ground	Ground
NC		4, 5, 12, 13, 20, 21, 28, 29		Not connected

6.0 Electrical Specifications

6.1 Absolute Maximum Ratings

Table 2: Absolute Maximum Ratings

Parameter	Min.	Max.	Units
VDD/AVDD	-0.3	5.5	V
Input pin voltage, all pins	-0.3	VDD+0.3	V
Input pin current, all pins	-10	10	mA
Storage temperature	-55	125	°C
Lead temperature		300	°C for 10 seconds

Note: Stresses beyond those listed under "Absolute Maximum Ratings" may cause damage to the device. This is a stress rating only and functional operation of the device at these, or any other conditions beyond those indicated in the operational sections of this specification is not implied. Exposure to absolute maximum rating conditions for extended periods may affect device reliability.

6.2 Operational Characteristics

Table 3: Operational Characteristics

Symbol	Parameter	Min.	Typ.	Max.	Units
VDD	Supply voltage	3		5	V
ICC	Supply current (5V)		18		mA
ICC	Supply current (3V)		8		mA
IFI	IF frequency ⁽¹⁾			11	MHz
IFE	IF frequency ⁽²⁾			25	MHz
RXiv	Input voltage	200	300		mVpp
RXii	Input impedance ⁽³⁾		100		kΩ
Fref	Reference frequency		2		MHz
Rsol	RSSI 1&2 output level	0		2.5	V
Srte	Internal sample rate	1.56		100	MHz

Notes:

- (1) Using the internal A to D converter
- (2) Using an external A to D converter
- (3) Impedance for only the RXin pin

6.3 Supply Current for 5V Operation

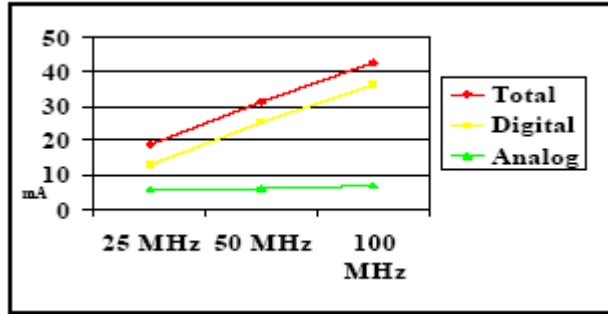

Figure 3: Supply Current for 5V Operation

Note: The frequency in MHz is the frequency of the internal clock, Fvco.

6.4 Supply Current for 3V Operation

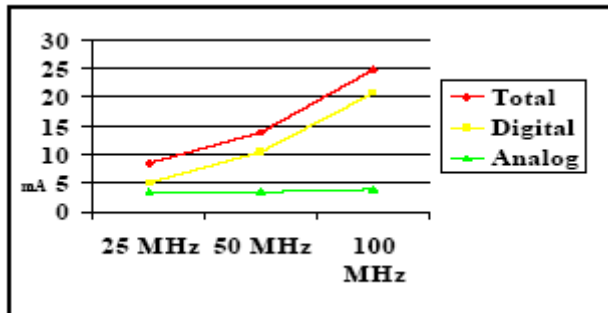

Figure 4: Supply Current for 3V Operation

Note: The frequency in MHz is the frequency of the internal clock, Fvco.

6.5 AMIS-50051 Programming Interface

The AMIS-50051 uses a 3-wire interface, enable/clock and data. The enable is active low.

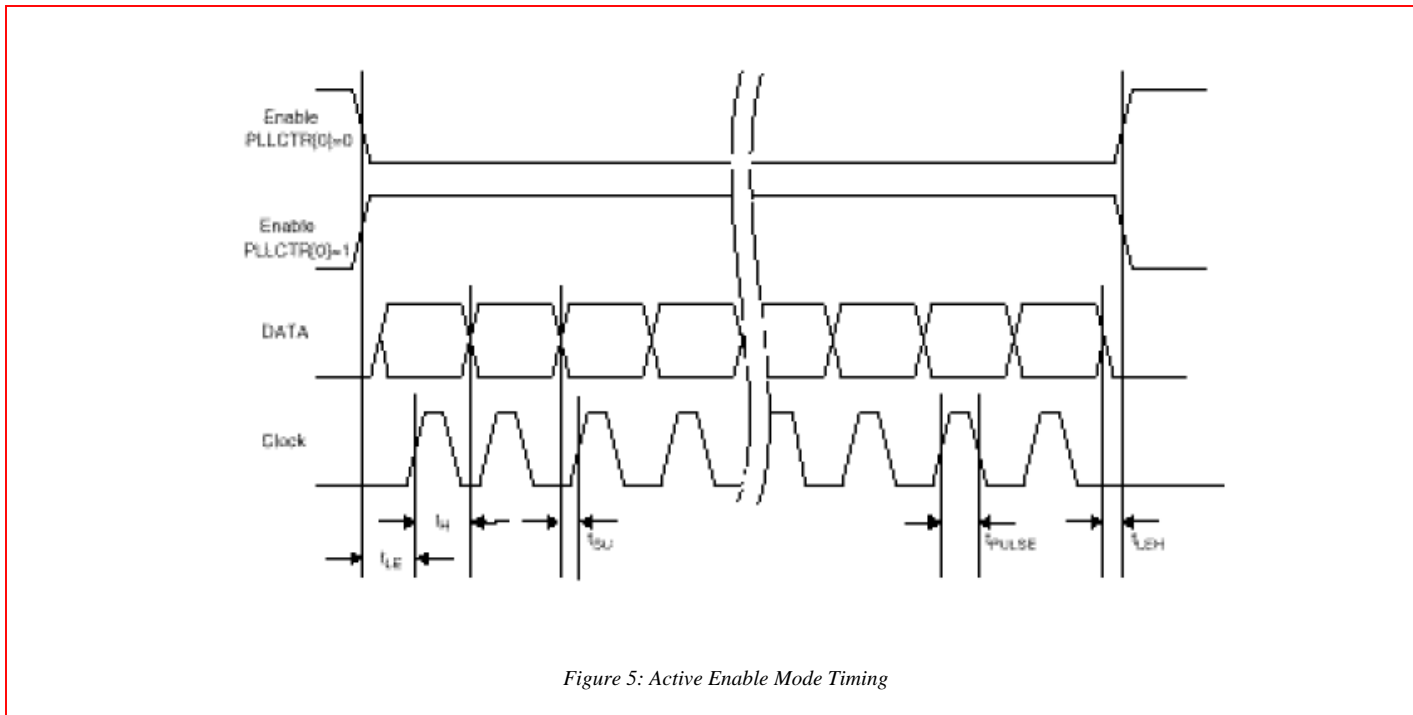

Figure 5: Active Enable Mode Timing

Table 4: Active Enable Timing Specifications

Parameter	Typical Slow Mode	Typical Fast Mode	Units
t _{LE}	16	0.500	μsec
t _{LH}	12	0.125	μsec
t _{SU}	4	0.125	μsec
t _{PULSE}	8	0.250	μsec
t _{LEH}	8	0.250	μsec

Note: The AMIS-50051 uses the three wire serial interface for programming. The protocol used is the "Active Enable" mode with a slow clock and enable active low.

6.6 Typical AMIS-50050 to AMIS-50051 Code

It is recommended to program the AMIS-50051 via the AMIS-50050. AMIS applications notes to support customer programming are available.

7.0 AMIS-50051 Ordering Codes

Table 5: Ordering Codes

Device Number	Package
11564-502-XTP (or -XTD)	24 Lead SOIC
11564-503-XTP (or -XTD)	32 Lead LQFP
11564-504-XTP (or -XTD)	32 Lead LQFP (green/RoHS)

Note: XTP – tape and reel. XTD – tube/tray

8.0 Company or Product Inquiries

For more information about AMI Semiconductor, our technology and our product, visit our Web site at: <http://www.amis.com>.

North America

Tel: +1.208.233.4690

Fax: +1.208.234.6795

Europe

Tel: +32 (0) 55.33.22.11

Fax: +32 (0) 55.31.81.12

www.DataSheet4U.com

Devices sold by AMIS are covered by the warranty and patent indemnification provisions appearing in its Terms of Sale only. AMIS makes no warranty, express, statutory, implied or by description, regarding the information set forth herein or regarding the freedom of the described devices from patent infringement. AMIS makes no warranty of merchantability or fitness for any purposes. AMIS reserves the right to discontinue production and change specifications and prices at any time and without notice. AMI Semiconductor's products are intended for use in commercial applications. Applications requiring extended temperature range, unusual environmental requirements, or high reliability applications, such as military, medical life-support or life-sustaining equipment, are specifically not recommended without additional processing by AMIS for such applications. Copyright ©2006 AMI Semiconductor, Inc.