

1.0 General Description

The AMIS-710208-A7 (PI208MC-A7) is a contact image sensor (CIS) module containing contact image sensors, using MOS image sensor technology for high-speed performance and high sensitivity. The AMIS-710208-A7 is designed to scan documents with a short read length of 88mm. The module produces a single stream of sampled analog video proportional to images of a single horizontal line scan that is stepped vertically down a document page with a resolution of 8 dots per millimeter (dpm) and a width of 88mm. Applications include fax machines, game systems, variety of mark readers, and other automation equipment requiring document scanners.

2.0 Key Features

- Light source, lens and sensor are integrated into a single module
- 8dpm resolution, 88mm scanning length
- Up to 176 μ sec/line scanning speed, with 4MHz pixel rate (see Table 3, Note 2)
- Wide dynamic range
- 660nm light source
- Compact size \cong 13mm x 25.6mm x 102mm
- Low-power
- Light weight

3.0 Functional Description

The AMIS-710208-A7 imaging array consists of 11 AMIS-720233 (PI3033B) sensors, produced by AMIS, which are cascaded together to provide 704 photo-detectors (pixels) with their associated multiplex switches, and a digital shift register that controls its sequential readout. Each sensor is sequentially connected to initiate its scanning process at completion of its predecessor's scan.

www.DataSheet4U.com

Mounted in the module is a one-to-one graded-indexed micro lens array that focuses the image to be scanned onto the linear array pixels. The incident image is converted to an electrical signal and then the charge on each pixel is transferred to a common video line. The charge on each pixel is then converted to a voltage by a single video amplifier. The module output is then available on Pin 1 of the connector, Vout.

Illumination is by means of an integrated LED light source. All components are housed in a small plastic housing which has a cover glass that acts as the focal point for the object being scanned. In addition, it protects the imaging array, micro lens assembly and LED light source from dust.

Inputs and outputs (I/O's) to and from the module are by an 8-pin connector, located on one end of the module. A cross-section of the AMIS-710208-A7 module is shown in Figure 1 and a block diagram in Figure 2.

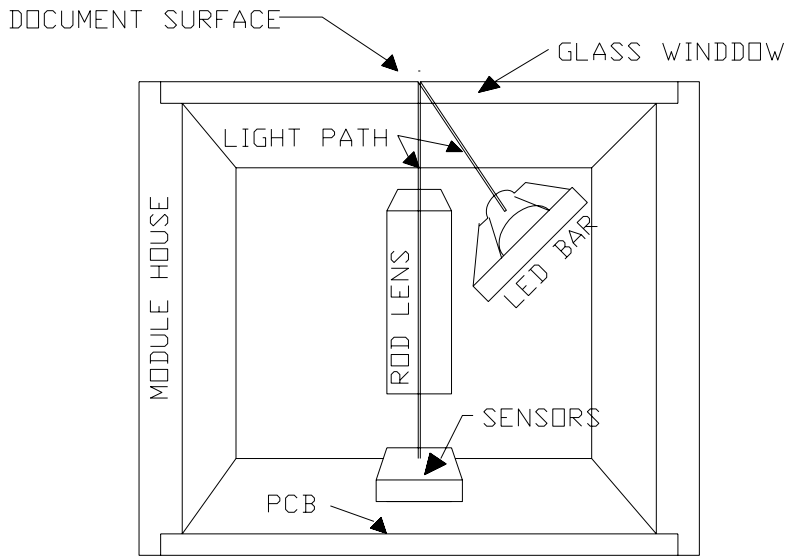

Figure 1: Cross Section

www.DataSheet4U.com

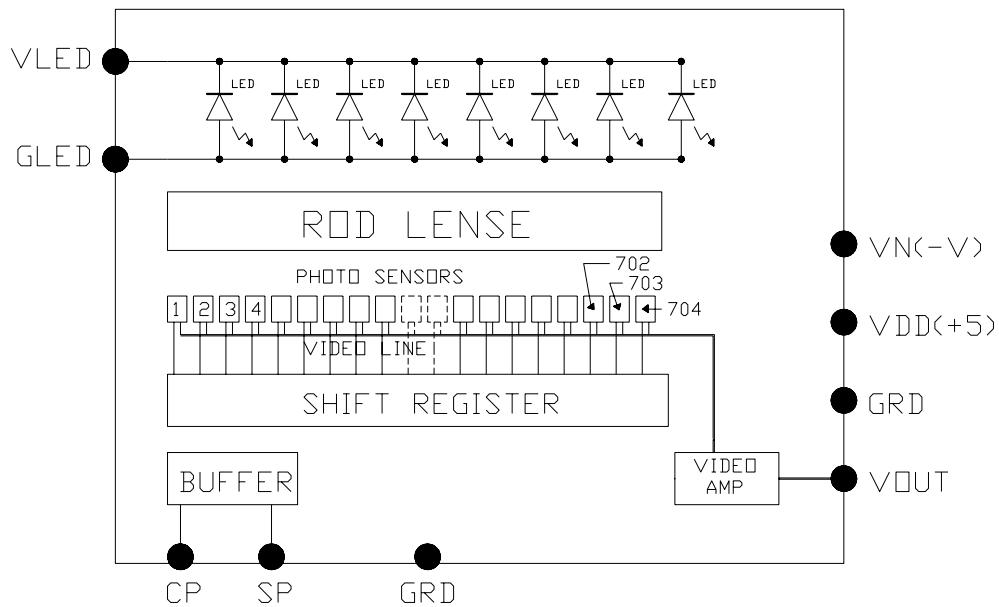

Figure 2: Block Diagram

4.0 Input/Output Terminals

Figure 3 shows location of the 8-pin connector, the control for adjusting the video gain and the contacts for the LED power supply. Note that the glass window is facing down.

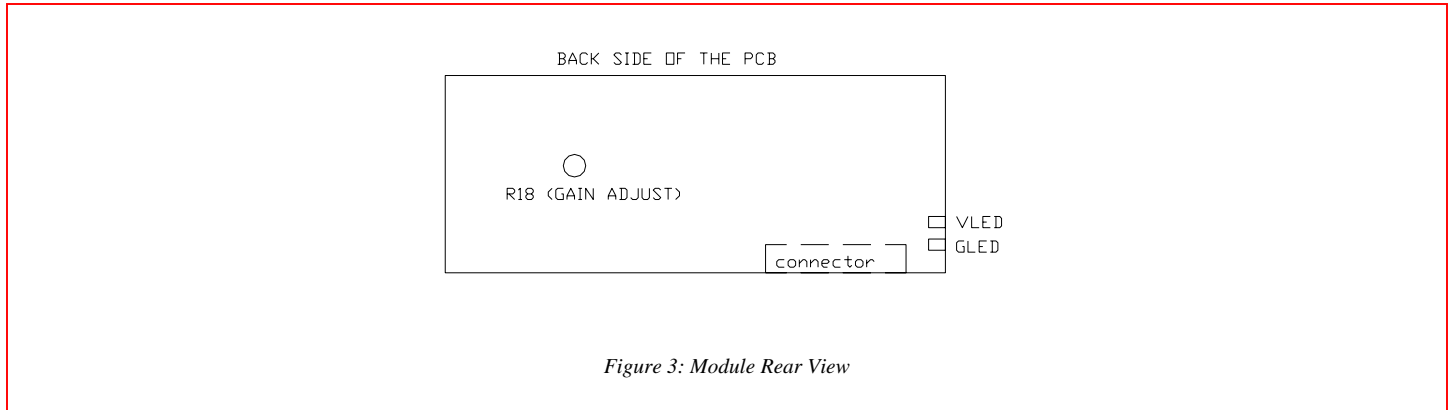

Figure 3: Module Rear View

“GAIN ADJUST” is used to change the analog gain. This is used to set the average video output (V_{pavg}) to a particular level when different exposure levels are employed. V_{pavg} is factory set with a particular exposure level. Note that the exposure is the product of light power and time of exposure (integration time). Since the module’s light power is a constant, then the total light exposure then depends on its integration time, which is the time between two Start Pulses (SP).

The integration time is set at the factory usually according to the customer requirements; V_{pavg} is then adjusted to a particular level. From this level, if the integration time is decreased or increased, the specified V_{pavg} will increase or decrease proportionally.

If it is necessary to restore the amplitude, within a limited range, it can be adjusted with the gain control.

V_{pavg} is measured with the module’s glass window facing down on a standard white uniform target similar to the standard white copy or typing paper.

The module connector is an 8-pin 1mm surface mount flex cable, part number Molex 52207-0890. Table 1 lists the connector pin-out and their descriptions.

Table 1: Pin Configuration

Pin Number	Symbol	Input/Output	Description
1	VOUT	O	Analog video output
2	Vdd	I	+5V power supply
3	Vn	I	-5V power supply
4	SP	I	SP for the shift register
5	GRD	I	Ground return for the module
6	CLOCK	I	Main clock input to the module shift register
7	GLED	I	Ground return for the LED light source
8	VLED	I	+5V power supply for the LED light source

5.0 Absolute Maximum Ratings

Table 2 lists the module's absolute maximum ratings.

Table 2: Maximum Ratings

Parameter	Symbols	Max. Rating	Units
Power supply	Vdd	7	V
	Idd	50	mA
	Vn	-10	V
	In	30	mA
	VLED	5.5	V
	ILED	400	mA
Input clock pulse, high level	Vih	Vdd – 0.5	V
Input clock pulse, low level	Vil	-0.8	V

6.0 Recommended Operating Environment

Table 3 lists the module's recommended operating environment.

Table 3: Recommended Operating Environment

Parameter	Symbol	Range	Units
Operating temperature	Top	0 to 50	°C
Operating humidity	Hop	10 to 85	%
Storage temperature	Tstg	-25 to+75	°C
Storage humidity	Hstg	5 to 95	%

7.0 Electro-Optical Characteristics

www.DataSheet4U.com

Table 4 lists the electro-optical characteristics at 25°C

Table 4: Electro-Optical Characteristics at 25°C

Parameter	Symbol	Parameter	Units	Comments
Number of photo pixels		704		
Pixel-to-pixel spacing		125	μm	
Photo-response non-uniformity ⁽¹⁾	Up	<+/-30	%	
Adjacent pixel non-uniformity ⁽²⁾	Uadj	<25	%	
Dark non-uniformity ⁽³⁾	Ud	<100	mV	
Dark output voltage ⁽⁴⁾	Vd	200<Vd<300	mV	
Modulation transfer function ⁽⁵⁾	MTF	>50	%	

- Notes:**
1. $U_p = [(V_{pmax} - V_{pavg}) / V_{pavg}] \times 100\%$ or $[(V_{pavg} - V_{pmin}) / V_{pavg}]$ whichever is the largest. Where V_{pmax} is the maximum pixel value and V_{pmin} is the minimum pixel value in a single scan line.
 2. $U_{adj} = \text{MAX}\{[(V_p(n) - V_p(n+1))] / v_p(n)\}$.
 3. $U_d = V_{dmax} - V_{dmin}$; where V_{dmax} is the maximum pixel value and V_{dmin} is the minimum pixel value in the dark.
 4. V_d is the average dark level.
 5. $MTF = [(V_{pmax} - V_{pmin}) / (V_{pmax} + V_{pmin})] \times 100\%$. Depth of focus, DOF, is defined with the MTF. It is measured with the glass surface as the reference. V_{pmax} is the maximum output voltage at 100lp/inch, (At 1/2 of Nyquist Frequency). V_{pmin} is the minimum output voltage at 100lp/inch.

8.0 Recommended Operating Conditions

Table 5 lists the recommended operating conditions at 25°C

Table 5: Recommended Operating Conditions at 25°C

Parameter	Symbol	Min.	Typ.	Max.	Units
Power supply	Vdd	4.5	5.0	5.5	V
	Vn	-5.5	-5.0	-4.5	V
	VLED	4.5	5.0	5.5	V
	Idd	22	25	27	mA
	Ivn	4	5	6	mA
	ILED	100	150	200	mA
Input voltage at digital high	Vih	Vdd -1.0	Vdd - 0.5	Vdd	V
Input voltage at digital low	Vil	0		0.8	V
Clock frequency	Fclk		4.0	5.0	MHz
Clock pulse high duty cycle		25			%
Clock pulse high duration	Clock	62.5 ⁽¹⁾			ns
Integration time ⁽¹⁾	Tint	0.145 ⁽²⁾			ms
Line scan rate ⁽²⁾	Tint		176	μsec	@ 4.0MHz clock frequency
Clock frequency ⁽³⁾	Fclk		4.0		MHz
Bright output voltage ⁽⁴⁾	Vpavg		1.65 +/-0.05		Volts
Operating temperature	Top		25	50	°C

- Notes:**
1. The minimum tint is specified with the maximum 5.0MHz clock frequency.
 2. Tint is the line scan rate or integration time. It is the time between two start pulses. Hence, the minimum integration time is fixed by the highest clock frequency. Here it is specified with a 4.0MHz clock frequency.
 3. Fclk is the main clock frequency, as is the pixel rate. Although the specification uses 4.0MHz, the module operates up to a maximum clock frequency of 5MHz.
 4. $V_{pavg} = \sum V_p(n) / 704$; where V_p is the pixel amplitude in volts and where n is sequential pixel number in one line scan.

9.0 Timing Characteristics

The timing requirements are shown in Figure 4 and Table 6.

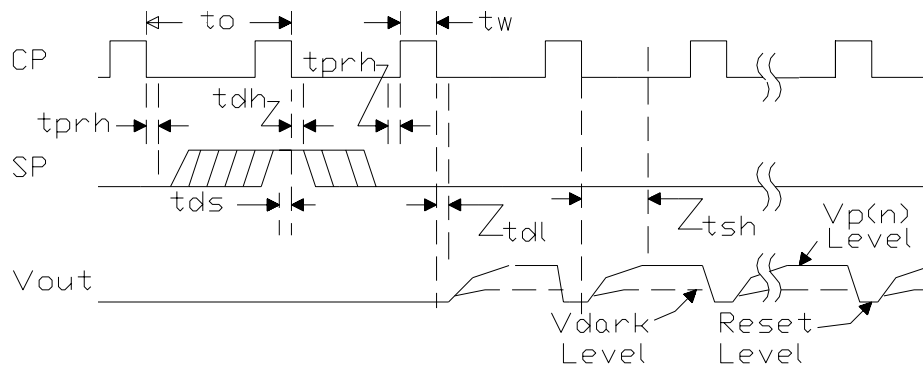

Figure 4: Timing Diagram

Table 6: Timing Requirements

Parameters	Symbol	Min.	Typ.	Max.	Units
Clock cycle time	t_o		0.50		μ s
Clock pulse width	t_w	62.5			ns
Clock duty cycle		25		50	%
Prohibit crossing time of SP	t_{prh}	15			ns
Data setup time	t_{ds}	20			ns
Data hold time	t_{dh}	20			ns
Reset level delay time	t_{dl}	50			ns
Signal sampling time	t_{sh}			120	ns

10.0 Module Mechanical Dimensions

Figure 5 shows the mechanical dimensions of the module housing.

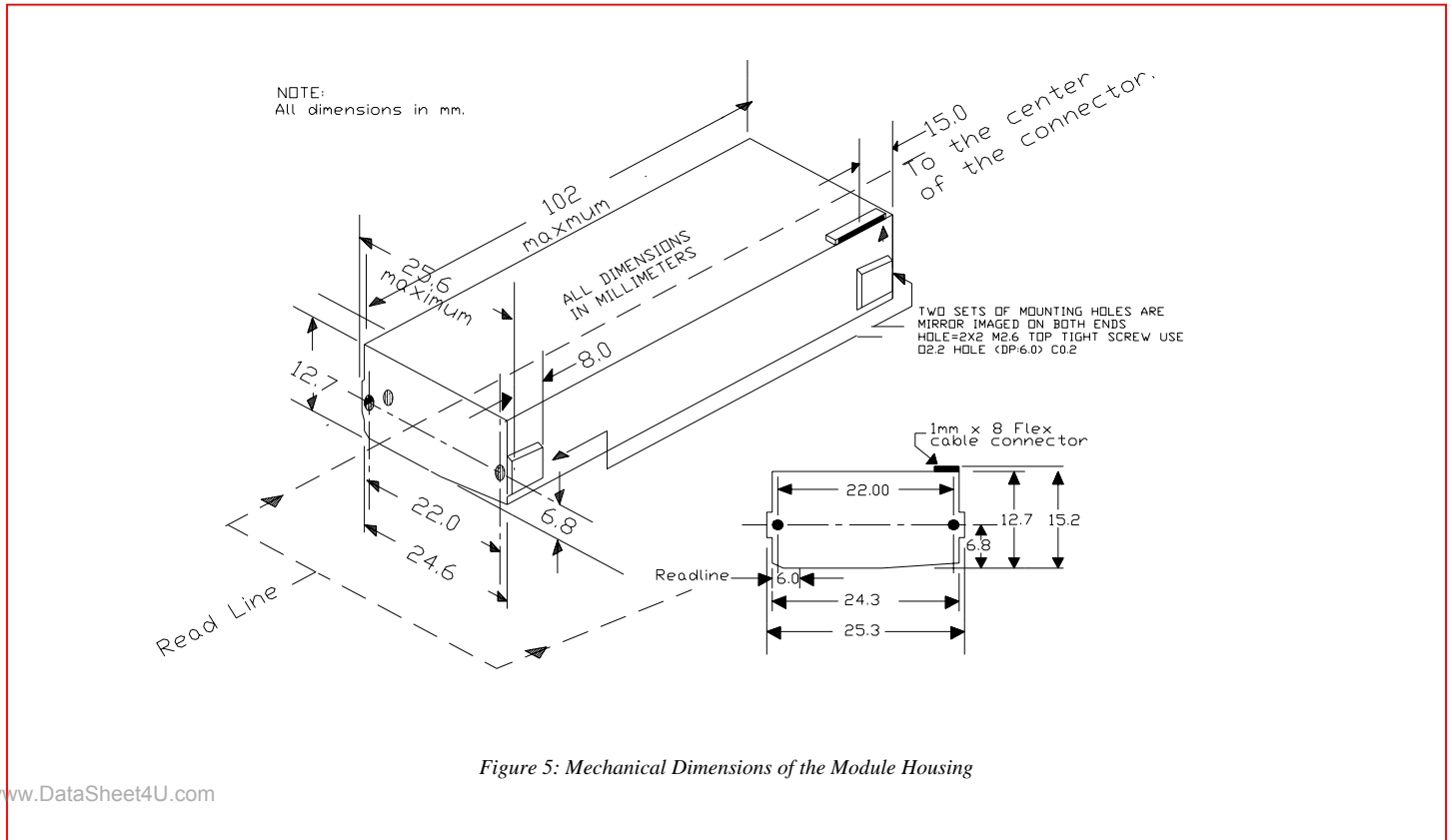

11.0 Company or Product Inquiries

For more information about AMI Semiconductor, our technology and our product, visit our Web site at: <http://www.amis.com>

North America

Tel: +1.208.233.4690

Fax: +1.208.234.6795

Europe

Tel: +32 (0) 55.33.22.11

Fax: +32 (0) 55.31.81.12

www.DataSheet4U.com

Production Technical Data - The information contained in this document applies to a product in production. AMI Semiconductor and its subsidiaries ("AMI") have made every effort to ensure that the information is accurate and reliable. However, the characteristics and specifications of the product are subject to change without notice and the information is provided "AS IS" without warranty of any kind (express or implied). Customers are advised to obtain the latest version of relevant information to verify that data being relied on is the most current and complete. AMIS reserves the right to discontinue production and change specifications and prices at any time and without notice. Products sold by AMIS are covered by the warranty and patent indemnification provisions appearing in its Terms of Sale only. AMIS makes no other warranty, express or implied, and disclaims the warranties of noninfringement, merchantability, or fitness for a particular purpose. AMI Semiconductor's products are intended for use in ordinary commercial applications. These products are not designed, authorized, or warranted to be suitable for use in life-support systems or other critical applications where malfunction may cause personal injury. Inclusion of AMIS products in such applications is understood to be fully at the customer's risk. Applications requiring extended temperature range, operation in unusual environmental conditions, or high reliability, such as military or medical life-support, are specifically not recommended without additional processing by AMIS for such applications. Copyright © 2006 AMI Semiconductor, Inc.