

1.0 General Description

The AMIS-710216 (PI216MC-DR) is a contact image sensor (CIS) module with an additional on board circuit that digitizes the analog pixels from the CIS image sensor to a “background-tracking”, two-level digital output signal. It is based on CIS module, the AMIS-710209-A6 (PI209M-A6) manufactured by AMIS, but with a shorter read length of 88mm. Hence, its performance is equivalent to the AMIS-710209-A6 which uses MOS image sensor technology to gain its high-speed performance and high sensitivity. The AMIS-710216 is suitable for scanning documents with width of 88mm and with resolution of 8 dots per millimeter (dpm). It has broad applications, but it was especially designed for the following areas:

- Where data compression is required, such as in data transmissions
- Where component pin-out count must be kept to a minimum

The background-tracking-digitizing circuits in the AMIS-710216 have been referred to as the “dynamic threshold” two-level A/D converter. For the purpose of describing the module’s characteristics this “dynamic threshold” processing circuit shall herein be referred to as the “tracking digitizer”.

2.0 Key Features

- Light source, lens and sensor are integrated into a single module
- 8dpm resolution, 88mm scanning length
- Up to 176µsec/line scanning speed, with 4MHz pixel rate (See Table 3, Note 3)
- Wide dynamic range
- Two-level tracking digital output (“Dynamic Threshold Digitizer”)
- 660nm light source (other colors available)
- Compact size \cong 13mm x 25.6mm x 102mm
- Low power
- Light weight

3.0 Module Description

www.DataSheet4U.com

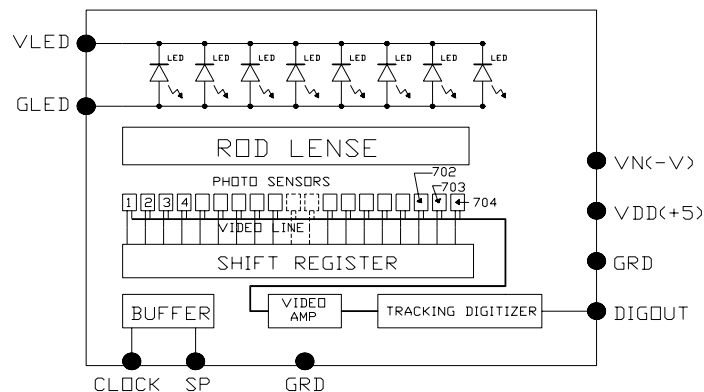
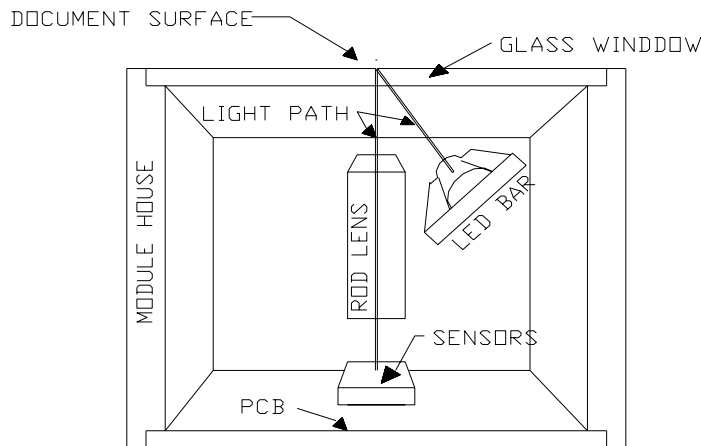

FIGURE 1. BLOCK DIAGRAM OF PI216MC-DR MODULE

Figure 1: Block Diagram of AMIS-710216

The AMIS-710216 module consists of 11 sensors that are cascaded to provide 704 photo-detectors with their associated multiplex switches, and a digital shift register that controls its sequential readout. Mounted in the module is one-to-one graded-indexed micro lens array that focuses the scanned documents to image onto its sensing plane. A buffer amplifier amplifies the video pixels from the image sensors and passes them to analog digitizing circuit, where the video pixels are converted to digital signal and passed to output of the module. See Figure 1, the block diagram of the AMIS-710216 module.

Illumination is accomplished by means of an integrated LED light source. All components are housed in a small plastic housing with a cover glass which acts as the focal point for the object being scanned and protects the imaging array, the micro lens assembly and the LED light source from dust. The pictorial of AMIS-710216 cross section is shown in Figure 2.



INSIDE PICTORIAL
OF THE MODULE
FIGURE 2

Figure 2: Inside Pictorial of the Module

www.DataSheet4U.com

I/O to the module is an 8-pin flex cable connector (see I/O Connector, under Specifications) located on one end of the module. The connector is on the top of the module with the glass window facing down and it is located on the opposite side of the module. See the Mechanical Housing under Mechanical Structure.



4.0 Circuit Description and Operation

See Figure 3 for a simplified block diagram of the analog tracking digitizer. Fundamentally, the tracking digitizer transforms the signal output from a CIS module existing on the market today. It takes the analog signal from the CIS section of AMIS-710216 and derives a tracking background reference signal. Then this reference is compared against the output signals from the CIS section. The resulting signal from the comparison produces a two-level digital signal that is high when the pixel signal is brighter than the background and remains at zero as long as the signal is darker than the background signal.

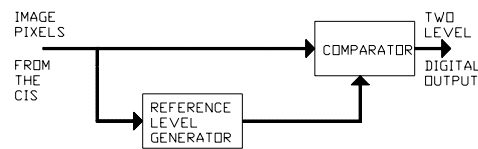

ANALOG SIGNAL REFERENCE
GENERATOR AND A SINGLE
BIT COMPARATOR
FIGURE 3

Figure 3: Analog Signal Reference Generator and a Single-bit Comparator

Figure 1 depicts the two basic circuits, the CIS (image sensors and video amplifier) and the tracking digitizer. In the CIS section, the module has 11 serially concatenated AMIS-720234 (PI3034) image sensors, accordingly, the image sensors will span one scanning-read line width that is 11 sensor times 64 pixel elements/sensor, or 704 pixel elements.

In operation, the module produces the analog image pixel signals that are proportional to exposure on the corresponding picture element on the document (the video signal) then passes the signal to the tracking digitizer. In turn, the digitizer processes the analog image pixels to digital image pixels. The analog image pixels, at test point TV, are separated into two signals. One generates the reference signal and the other remains unmodified. These unmodified image pixels are applied to one of the input of the comparator. The reference signal is applied to the second input of the comparator. The results of the comparison are the digital image pixels. This digital output is produced in two levels, determined by the difference between the background reference signal and the analog image pixels. A digital pixel output of value "one" represents the analog image pixel that is brighter than the background and digital pixel level of value "zero" represents the image pixel that is darker than background.

5.0 Specifications

The I/O connector pins and their functions is listed in Table 1.

Table 1: Pin Configuration

Pin Number	Symbol	Names and Functions
1	DIGOUT	Digital video output
2	Vdd (+5V)	Ground; 0V
3	Vn (-5V)	Negative power supply
4	SP	Start pulse for the shift register
5	GRD	Ground; 0V
6	CLOCK	Clock for the shift register
7	GLED	Return for the LED light source
8	VLED	Power in for the LED light source.

The connector is an 8-pin 1mm surface mount flex input, Molex 52207-0890.

5.1 Inputs

There are five inputs:

- Clock is on Pin 6 of the I/O connector. This is main clock input into the CIS module.
- SP is on Pin 4. This is the start clock input to the CIS module.
- VDD is on Pin 2. This is a +5V supply.
- VN is on Pin 3. This is a -5V supply.
- VLED is on Pin 8. This is a +5V supply for the LED light source.

Note: Power return for the LED light source is GLED on Pin 7 and the ground return for the CIS modules is Pin 5.

5.2 Video Output

DIGOUT is on Pin 1 of the I/O connector. This is the digital video output from the CIS module. Reflection off the dark target produces a digital signal of "0" level, while the white reflection off the white target produces a digital level of "one". The amplitudes of the white and dark are listed in the table below:

6.0 Electro-Optical Characteristics (25°C)

Table 2: Electro-Optical Characteristics (25°C)

Parameter	Symbol	Parameter	Units	Note
Number of photo detectors		704	Elements	
Pixel-to-pixel spacing		125	µm	
Line scanning rate	Tint ⁽¹⁾	352	µsec	@ 2.0MHz clock frequency
Clock frequency	f	2.0	MHz	
Bright output	Digital video output signal	>3.5	V	
Dark output		<0.8	V	

Note:

1. The tint is specified with a 2.0MHz clock frequency. In operation, the time constants in the reference generator is set to match the initial exposure time, hence the time constant will determine the optimum integration time. Note that the integration time is also a function of the clock frequency. Accordingly, it is highly recommended that the parameters be factory adjusted for the specific applications. Although the specification is shown nominally at 2.0MHz, the maximum clock frequency is 4.0MHz.

Table 3: Recommended Operating Conditions (25°C)

Item	Symbol	Min.	Mean	Max.	Units
Power supply	Vdd		5.0		V
	Vn		-5.0		V
	VLED		5 ⁽¹⁾		V
	Idd		85		mA
	Ivn		15		mA
	ILED		300		mA
Input voltage at digital high	Vih	Vdd-1.0	Vdd-.5	Vdd	V
Input voltage at digital low	Vil	0		0.8	V
Clock frequency	f			4.0	MHz
Clock pulse high duty cycle		25			%
Clock pulse high duration	Clock	62.5 ⁽²⁾			ns
Integration time	Tint	0.176 ⁽³⁾			ms
Operating temperature	Top		25	50	°C

- Notes:**
- VLED sources are also available from 5 to 24V.
 - Clock pulse high is specified at 4.0MHz at 25 percent duty.
 - The tint is specified with the maximum 4.0MHz clock frequency. In operation, the time constants in the reference generator is set to match the initial exposure time, hence the optimum integration time will be set by optimum integration time. Accordingly, it is highly recommended that the parameters be factory adjusted for the specific applications

7.0 Switching Characteristics (25°C)

The switching characteristics for the I/O clocks are shown in Figure 4. The timing parametric values and their symbols are given in the Table 4.

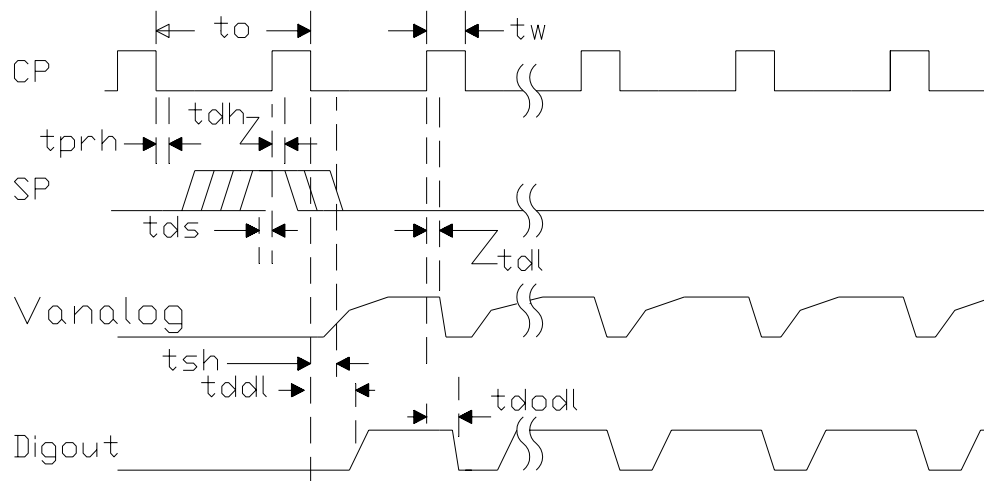

MODULE TIMING DIAGRAM
FIGURE 4

Figure 4: Module Timing Diagram

Table 4: Switching Parameters and Timing Symbol Definitions

Parameter	Symbol	Min.	Typ.	Max.	Units
Clock cycle time	to		0.50		µs
Clock pulse width	tw	62.5			ns
Clock duty cycle		25		50	%
Prohibit crossing time of SP	tprh	15			ns
Data setup time	tds	20			ns
Data hold time	tdh	20			ns
Signal delay time	tdl	50			ns
Signal settling time	tsh			120	ns
Digital signal delay	tddl		60		ns
Digital signal off delay	tdodl		20		ns

8.0 Absolute Maximum Rating

Table 5: Absolute Maximum Rating

Parameter	Symbols	Maximum Rating	Units
Power supply voltage	Vdd	10	V
	Idd	100	mA
	Vn	-10	V
	In	30	mA
	VLED	5.5	V
	ILED	400	mA
Input clock pulse (high level)	Vih	Vdd - 0.5	V
Input clock pulse (low level)	Vil	-0.8	V

Table 6: Operating Environment

Parameter	Symbols	Maximum Rating	Units
Operating temperature	Top	0 to 50	°C
Operating humidity	Hop	10 to 85	%
Storage temperature	Tstg	-25 to +75	°C
Storage humidity	Hstg	5 to 95	%

www.DataSheet4U.com

9.0 Setup and Adjustments

9.1 The Clock Rate and Integration Time

This was factory set to a specific application. See Note 1 under Table 2.

The clock frequency was set to 2.0MHz.
The total integration time was set to 360µsec.

9.2 The Required Power

The required power is slightly greater than the specified values in Table 3.

Circuit Power:

- Positive supply: +5V @ 90mA
- Negative supply: -5V @ 20mA
- LED power: +5V @ 300mA

9.3 Adjustments

General location of test, adjustment and monitor points.

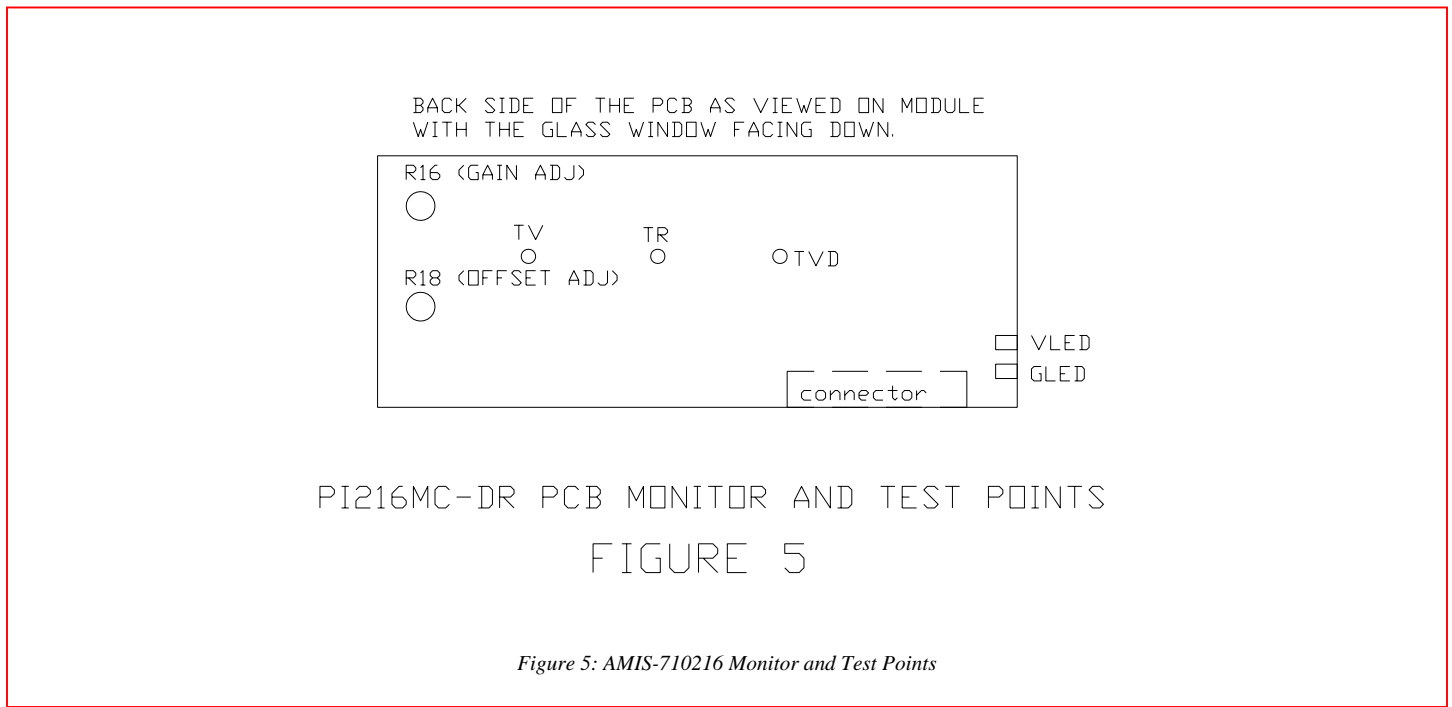

Figure 5 shows the pictorial layout of the controls and the tests points. These adjustment potentiometers and the test points are shown relative to the connector and to the output pads for LED light power. This is a bird's eye view of the PCB's backside with the glass window of the module facing down on the documents.

The test point labeled TV is for the analog image pixels, just as it is produced at the output of the CIS array section, and prior to its entry into the tracking digitizer circuit.

The test point labeled TR is the output of the tracking reference level from the tracking digitizer circuit.

The test point labeled TVD is the digital output from the comparator.

The offset adjust, R18, is a screw driver adjustment potentiometer that is accessed through adjustment hole as viewed in Figure 5.

Gain adjust, R16, is a screw driver adjustment potentiometer that is accessed through the hole as it is viewed in Figure 5.

9.4 There Are Only Two Adjustments

These adjustments will be pre-adjusted to the customer's specific application at the factory; therefore, in general will not require adjustments by the user. The test point TV is probed with a scope to monitor the analog image pixel levels. The probe should be grounded as close to the CIS module as possible. If possible, it should be grounded right on the ground input lead, Pin 5, of the I/O connector.

Analog zero signal adjust (OFFSET ADJ) is shown in Figure 5. This potentiometer is adjusted to place the dark level of the analog image pixel signal to approximately 1.0V and is normally adjusted with intended targets.

Analog gain adjust, "GAIN", is adjusted greater than 2.5 and less than 3.0V with the CIS imaged on a standard white target, similar to the standard white copy or typing paper.

10.0 Mechanical Structure

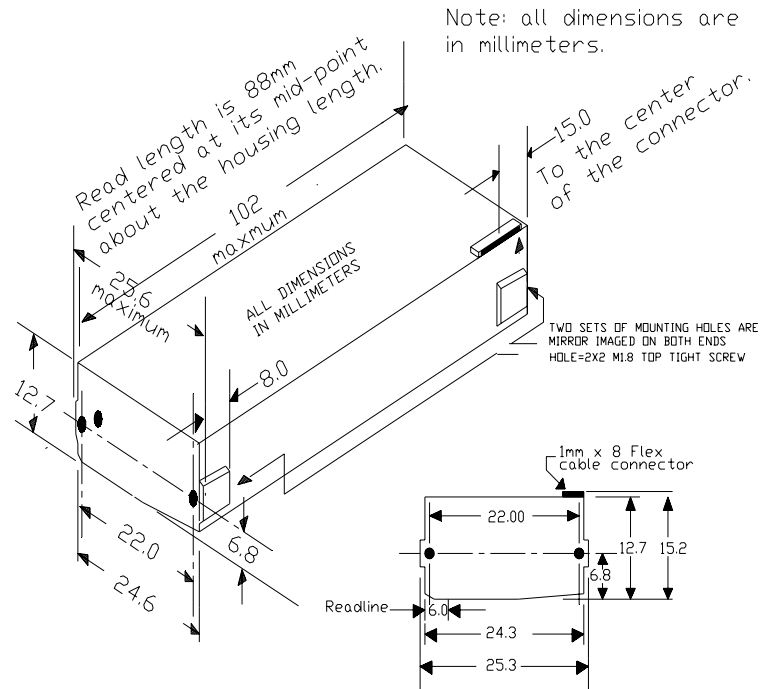

FIGURE 6 MECHANICAL STRUCTURE

www.DataSheet4U.com

Figure 6: Mechanical Structure

Figure 6 is pictorial of the AMIS-710216. It shows the mechanical dimensions of the housing and its mounting hole locations.

11.0 Company or Product Inquiries

For more information about AMI Semiconductor, our technology and our product, visit our Web site at: <http://www.amis.com>

North America

Tel: +1.208.233.4690

Fax: +1.208.234.6795

Europe

Tel: +32 (0) 55.33.22.11

Fax: +32 (0) 55.31.81.12

www.DataSheet4U.com

Production Technical Data - The information contained in this document applies to a product in production. AMI Semiconductor and its subsidiaries ("AMIS") have made every effort to ensure that the information is accurate and reliable. However, the characteristics and specifications of the product are subject to change without notice and the information is provided "AS IS" without warranty of any kind (express or implied). Customers are advised to obtain the latest version of relevant information to verify that data being relied on is the most current and complete. AMIS reserves the right to discontinue production and change specifications and prices at any time and without notice. Products sold by AMIS are covered by the warranty and patent indemnification provisions appearing in its Terms of Sale only. AMIS makes no other warranty, express or implied, and disclaims the warranties of noninfringement, merchantability, or fitness for a particular purpose. AMI Semiconductor's products are intended for use in ordinary commercial applications. These products are not designed, authorized, or warranted to be suitable for use in life-support systems or other critical applications where malfunction may cause personal injury. Inclusion of AMIS products in such applications is understood to be fully at the customer's risk. Applications requiring extended temperature range, operation in unusual environmental conditions, or high reliability, such as military or medical life-support, are specifically not recommended without additional processing by AMIS for such applications. Copyright © 2006 AMI Semiconductor, Inc.