

1.0 General Description

The AMIS-710322-A4 (PI322MC-A4) is a contact image sensor (CIS) module, which uses MOS image sensor technology for high-speed performance and high sensitivity. The AMIS-710322-A4 is suitable for scanning A4 size (216mm) documents with 11.8 dots per millimeter (dpm) resolution. Applications include fax machines, game systems, a variety of mark readers, and other automation equipment requiring document scanners.

2.0 Key Features

- Light source, lens and sensor are integrated into a single module
- 11.8dpm resolution, 216mm scanning length
- Up to 500 μ sec/line scanning speed with optional light source
- Wide dynamic range
- Analog output
- Yellow-green LED light source
- Compact size \cong 14mm x 19.5mm x 232mm
- Low power
- Light weight

3.0 Functional Description

The AMIS-710322-A4 imaging array consists of 27 sensors, AMIS-720341 (PI3041) produced by AMIS, which are cascaded to provide 2592 photo-detectors with their associated multiplex switches and a digital shift register, which controls its sequential readout. Mounted in the module is a one-to-one graded indexed micro lens array, which focuses the scanned documents to image onto its sensing plane. The on-board amplifier processes the video signal to produce a sequential stream of video at the video output pin of the AMIS-710322-A4 module.

Illumination is accomplished by means of an integrated LED light source. All components are housed in a small plastic housing which has a cover glass, which acts as the focal point for the object being scanned and protects the imaging array, micro lens assembly and LED light source from dust. I/O to the module is the 10-pin connector located on one end of the module. The cross section of the AMIS-710322-A4 is shown in Figure 1 and the block diagram in Figure 2.

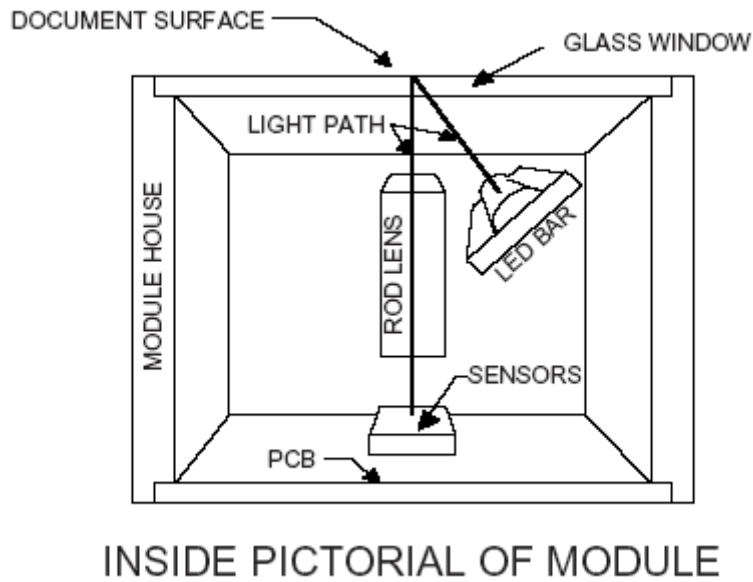

Figure 1: AMIS-710322-A4 Cross Section

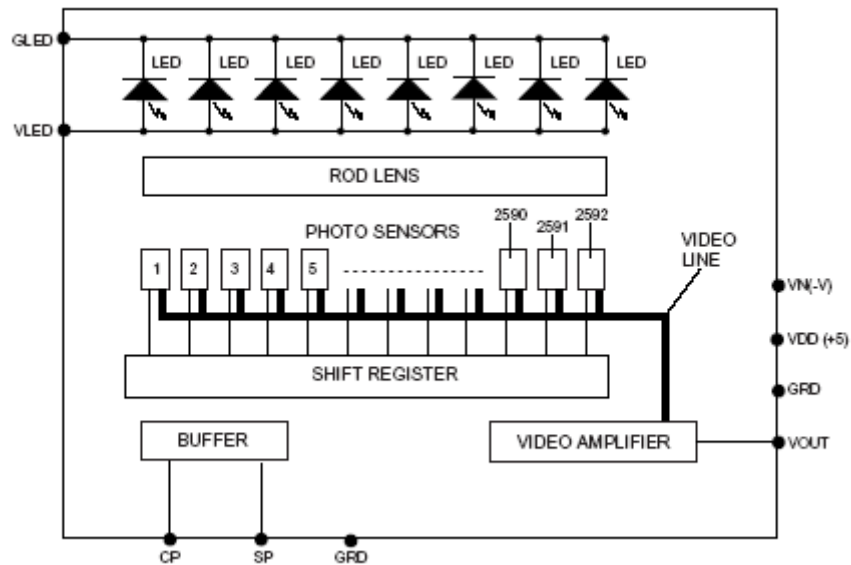

Figure 2: AMIS-710322-A4 Module Block Diagram (See Table 1 for Pin Out Designation)

Table 1: Pin Configuration

Pin Number	Symbol	Names and Functions
1	Vout	Analog video output
2	Gnd	Ground; 0V
3	Vdd (+5 V)	Positive power supply
4	Vn (-5V to -12V)	Negative power supply
5	Gnd	Ground; 0V
6	SP	Shift register start pulse
7	Gnd	Ground; 0V
8	CP	Sampling clock pulse
9	GLED	Ground for the light source; 0V
10	VLED	Supply for the light source

4.0 Operational Environment

4.1 Absolute Maximum Rating

Table 2: Absolute Maximum Rating

Parameter	Symbols	Maximum Rating	Units
Power supply voltage	Vdd	10	V
	Idd	55	ma
	Vn	-15	V
	In	10	ma
	VLED	12.5	V
	ILED	0.6	A
Input clock pulse (high level)	Vih	Vdd – 0.5V	V
Input clock pulse (low level)	Vil	-0.8	V

4.2 Operating Environment

Table 3: Operating Environment

Parameter	Symbols	Maximum Rating	Units
Operating temperature	Top	0 to 50	°C
Operating humidity	Hop	10 to 85	%
Storage temperature	Tstg	-25 to +75	°C
Storage humidity	Hstg	5 to 95	%

4.3 Electro-Optical Characteristics (25°C)

Table 4: Electro-Optical Characteristics at 25°C

Parameter	Symbol	Parameter	Units	Note
Number of photo detectors		2592	Elements	
Pixel-to-pixel spacing		84.7	µm	
Line scanning rate	Tint ⁽¹⁾	865	µsec	@ 3.0MHz clock frequency
Clock frequency ⁽²⁾	f	3.0	MHz	
Bright output voltage	Video output	1.0	V	
Bright output non-uniformity ⁽⁴⁾	Up	<+/-30	%	
Adjacent pixel non-uniformity ⁽⁵⁾	Uadj	<25	%	
Dark non-uniformity ⁽⁶⁾	Ud	<100	mV	
Dark output voltage	Vd	<150	mV	
Modulation transfer function ⁽⁷⁾	MTF	>50	%	See Note 7 for MTF & DOF

- Notes:**
- (1) Tint: line scanning rate or integration time. Tint is determined by the interval of two start pulses (SP). The minimum integration time of 500µs is available at a 5.2MHz pixel rate but it will require optional light sources.
 - (2) f: main clock frequency
 - (3) $V_{pavg} = \bar{a} V_p(n)/2592$
 - (4) $U_p = [(V_{pmax} - V_p) / V_p] \times 100\%$ or $[(V_p - V_{pmin}) / V_p] \times 100\%$
 - (5) $U_{adj} = \text{MAX}[| (V_p(n) - V_p(n+1)) | / V_p(n)] \times 100\%$
Uadj is the non-uniformity percentage pixel to pixel
 - (6) $U_d = V_{dmax} - V_{dmin}$
Vdmin is the minimum output on a black document (O.D.=0.8).
Vdmax: maximum output voltage of a black document (O.D.= 0.8).
 - (7) $MTF = [(V_{max} - V_{min}) / (V_{max} + V_{min})] \times 100 [\%]$
Vmax: maximum output voltage at 75lp/in
Vmin: minimum output voltage at 75lp/in
 - (8) O.D. = optical density
 - (9) lp / in: line pairs per inch

4.4 Recommended Operating Conditions

Table 5: Recommended Operating Conditions at 25°C

Item	Symbol	Min.	Mean	Max.	Units
Power supply	Vdd	4.5	5.0	5.5	V
	Vn	-4.5	-5	-12	V
	VLED		12	12.5	V
	Idd		35	55	ma
	Ivn		6.0	10.0	ma
	ILED		460	600	ma
Input voltage at digital high	Vih	Vdd-1.0	Vdd-.5	Vdd	V
Input voltage at digital low	Vil	0		0.8	V
Clock frequency	f			5.5	MHz
Clock pulse high duty cycle		25			%
Clock pulse high duration		50			ns
Integration time	Tint	0.500*		5.0	ms
Operating temperature	Top		25	50	°C

Note: Tint (min.) is the lowest line integration time available with a 5.2MHz clock (see Note 1 under Optical Characteristics, Table 2).

5.0 Switching Characteristics (25°C)

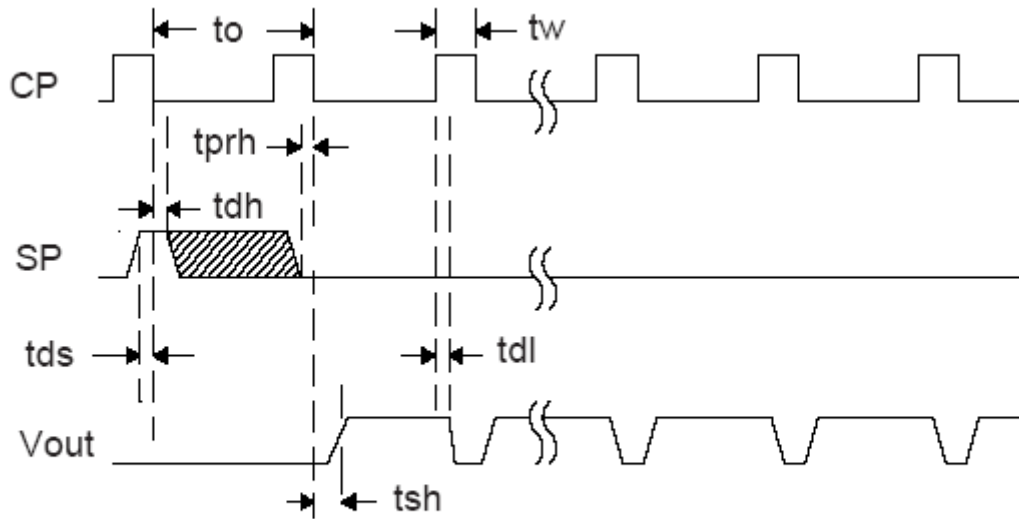

MODULE TIMING DIAGRAM

Figure 3: Module Timing Diagram

The switching characteristics for the I/O clocks are shown in Figure 3. See the timing symbol definitions in Table 6.

www.DataSheet4U.com

Table 6: Symbol Definition for Timing Diagram (Figure 3)

Item	Symbol	Min.	Typ.	Max.	Units
Clock cycle time	t_o	0.2		4.0	μ s
Clock pulse width	t_w	50			ns
Clock duty cycle		25		75	%
Prohibit crossing time of SP	t_{prh}	15			ns
Data setup time	t_{ds}	20			ns
Data hold time	t_{dh}	20			ns
Signal delay time	t_{dl}	50			ns
Signal sample and hold time	t_{sh}	120			ns

6.0 AMIS-710322-A4 Module and its Mechanical Dimensions

This is an overview drawing of the module. A full size drawing is available upon request.

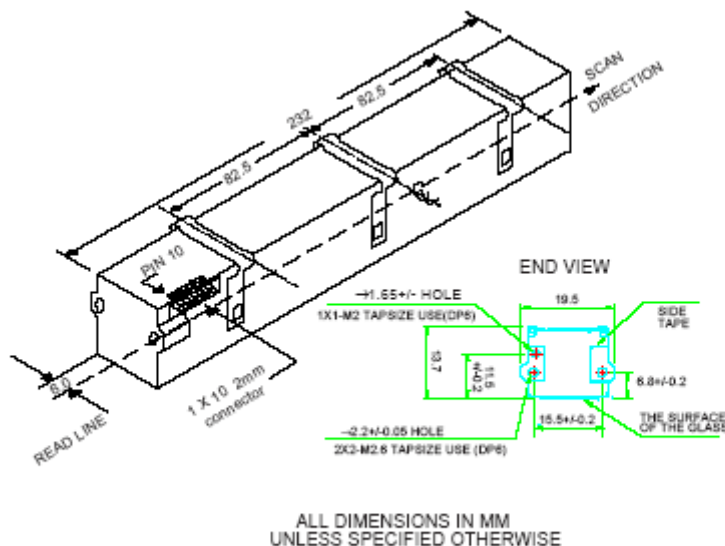

Figure 4: 6.0 AMIS-710322-A4 Module and its Mechanical Dimensions

7.0 Company or Product Inquiries

For more information about AMI Semiconductor, our technology and our product, visit our Web site at: <http://www.amis.com>

North America

Tel: +1.208.233.4690

Fax: +1.208.234.6795

Europe

Tel: +32 (0) 55.33.22.11

Fax: +32 (0) 55.31.81.12

www.DataSheet4U.com

Production Technical Data - The information contained in this document applies to a product in production. AMI Semiconductor and its subsidiaries ("AMIS") have made every effort to ensure that the information is accurate and reliable. However, the characteristics and specifications of the product are subject to change without notice and the information is provided "AS IS" without warranty of any kind (express or implied). Customers are advised to obtain the latest version of relevant information to verify that data being relied on is the most current and complete. AMIS reserves the right to discontinue production and change specifications and prices at any time and without notice. Products sold by AMIS are covered by the warranty and patent indemnification provisions appearing in its Terms of Sale only. AMIS makes no other warranty, express or implied, and disclaims the warranties of noninfringement, merchantability, or fitness for a particular purpose. AMI Semiconductor's products are intended for use in ordinary commercial applications. These products are not designed, authorized, or warranted to be suitable for use in life-support systems or other critical applications where malfunction may cause personal injury. Inclusion of AMIS products in such applications is understood to be fully at the customer's risk. Applications requiring extended temperature range, operation in unusual environmental conditions, or high reliability, such as military or medical life-support, are specifically not recommended without additional processing by AMIS for such applications. Copyright © 2006 AMI Semiconductor, Inc.